

State of California
AIR RESOURCES BOARD

Method 435

Determination of Asbestos
Content of Serpentine Aggregate

Adopted: June 6, 1991

Method 435

Determination of Asbestos Content of Serpentine Aggregate

1.0 Principle and Applicability

1.1 Principle:

Asbestos fibers may be released from serpentine rock formations and are determined by microscopic techniques. The results are very sensitive to sampling procedures. The analytical results are reported in percent asbestos fibers which is the percent number of asbestos fibers contained in 400 randomly chosen particles of a bulk sample. Since the homogeneity of the material is unknown, the uncertainty in the sampling cannot be defined. The uncertainty of the analytical technique is two percent if twenty asbestos fibers are counted in a sample of 400 particles. The derivation of this uncertainty value is explained in Section 7.4.

1.2 Applicability:

This method is applicable to determining asbestos content of serpentine aggregate in storage piles, on conveyor belts, and on surfaces such as roads, shoulders, and parking lots.

2.0 Definitions:

2.1 Bulk Sample - A sample of bulk material.

2.2 Grab Sample - A sample taken from a volume of material.

2.3 Composite Sample - A mixture or blend of material from more than one grab sample.

2.4 Serpentine - Serpentinite, serpentine rock or serpentine material.

2.5 Executive Officer - The term Executive Officer as used in this method shall mean the Executive Officer of the Air Resources Board (ARB) or Air Pollution Control Officer/Executive Officer of

a local air pollution control district/air quality management district.

3.0 Applicable Sources:

This method can be used to obtain bulk material samples from three types of sources:

1. Serpentine aggregate storage piles.
2. Serpentine aggregate conveyor belts.
3. Serpentine aggregate covered surfaces.

4.0 Sampling Apparatus

4.1 Serpentine Aggregate Storage Piles

Tube insertion often provides the simplest method of aggregate material investigation and sampling. Insertion tubes shall be adequate to provide a relatively rapid continuous penetration force.

4.1.1 Thin-walled tubes should be manufactured as shown in Figure 1. The tube should have an outside diameter between 2 to 5 inches and be made of metal or plastic having adequate strength for penetration into aggregate piles. These tubes shall be clean and free of surface irregularities including projecting weld seams. Further information on these tubes can be found in Table 1 and ASTM D 1587-83, which is incorporated herein by reference.

4.1.2 The insertion tube can be made out of commercially available two inch PVC Schedule 40 pipe. Further information on the tube can be found in Table 2.

4.1.3 A round point shovel may be used.

4.2 Serpentine Aggregate Conveyor Belts

4.2.1 Sampling of aggregate off a conveyor belt requires a hand trowel, a small brush, and a dust pan.

4.2.2 Two templates as shown in Figure 2 are needed to isolate material on the conveyor belt.

4.2.3 An automated belt sampler may be used.

4.3 Serpentine Aggregate Covered Surfaces

A shovel, a hand or machine-operated auger or other suitable equipment can be used to collect samples of aggregate materials on covered surfaces.

4.3.1 Hand-Operated Augers

4.3.1.1 Helical Augers—Small lightweight augers such as spiral-type augers and ship-type augers may be used. A description of these auger types can be found in ASTM D 1452-80, which is incorporated herein by reference.

4.3.1.2 Orchard barrel and open spiral type tubular augers may be used to collect samples. These augers range in size from 1.5 through 8 inches, and have the common characteristic of appearing essentially tubular when viewed from the digging end. Further description of these auger types can be found in ASTM D 1452-80.

4.3.1.3 Clam Shell or Iwan Type post-hole augers may be used to collect samples from surfaces generally 2 through 8 inches in diameter and have a common mean of blocking the escape of soil from the auger. Further description of these augers can be found in ASTM D 1452-80.

4.3.2 Machine-Operated Augers

Machine-Operated Augers such as helical augers and stinger augers may be used. These augers are normally operated by heavy-duty, high-torque machines, designed for heavy construction work. Further description of these augers can be found in ASTM D 1452-80.

4.3.3 A round point shovel can also be used to obtain a sample of aggregate covered surface material.

5.0 Sampling

The sampling procedure has been developed to provide an unbiased collection of bulk samples. A sampling plan, including a description of how the grab samples will be randomly collected and the number of samples to be collected, shall be developed.

Prior to conducting any sampling the sampling plan shall be submitted to the Executive Officer for approval, if the sampling is conducted for determining compliance with a rule or regulation. The amount of composite 200 mesh material, as described below, shall be sufficient to provide a sample to the source or Executive Officer, if requested, and a sample to be archived for future use.

A single test as described below shall cover:

- a) 1000 tons of aggregate for piles and conveyor belts, or
- b) one acre aggregate covered surface, or
- c) one mile of aggregate covered road, or
- d) two acres or two miles of dual aggregate covered shoulders.

Exposure to airborne asbestos fibers is a health hazard. Asbestos has been listed by the Governor as causing cancer and identified by the Air Resources Board as a toxic air contaminant.

Serpentine aggregate may contain asbestos. Bulk samples collected can contain friable asbestos fibers and may release fibers during sampling, handling or crushing steps. Adequate safety precautions should be followed to minimize the inhalation of asbestos fibers. Crushing should be carried out in a ventilated hood with continuous airflow (negative pressure) exhausting through an HEPA filter. Handling of samples without these precautions may result in the inhalation of airborne asbestos fibers.

5.1 Serpentine Aggregate Storage Piles

Serpentine aggregate storage piles typically have a conical or a triangular prism shape. The aggregate is introduced at the top of the pile and is allowed to flow over the side. This action, called sloughing, causes a size segregation to occur with the finer material deposited towards the top of the pile.

The locations where grab samples will be taken are randomly chosen over the surface of the pile. The method of randomly choosing the sampling locations is left up to sampling personnel but must follow the procedures specified in the sampling plan.

For 1000 tons of product, a grab sample shall be taken at a minimum of three randomly chosen sampling locations. A minimum of three grab samples shall be taken even if the product pile contains less than 1000 tons of material. The slough is raked or shoveled away from the sampling location. A sampling apparatus is inserted one foot into the pile and the material is removed and is placed in an appropriate sized sampling container. Some of the possible sampling apparatus is discussed in Section 4.1.

Each of the grab samples shall be placed in the same sample container. This composited sample shall be crushed to produce a material with a nominal size of less than three-eighths of an inch. Before crushing, the sample must be adequately dried. ASTM Method C-702-80, which is incorporated herein by reference, shall be used to reduce the size of the crushed grab sample to a one pint aliquot. The one pint aliquot, shall be further crushed using a Braun mill or equivalent to produce a material of which the majority shall be less than 200 Tyler mesh. An aliquot of the 200 mesh material shall be put into a labeled sealed container. The label shall contain all the information described in Section 6 (except item 4).

5.2 Serpentine Aggregate Conveyor Belts

Serpentine aggregate is transported from the rock crushing plant to a product stacking belt and finally to a storage pile or to a waiting truck for delivery to a buyer.

The grab samples shall be taken from the product stacking belt or if this is not possible then at the first transfer point before the stockpile. The grab samples shall be collected by stopping the belt a minimum of three times or using an automated sampler.

The method of randomly choosing the sampling locations and intervals is left up to sampling personnel but must follow the procedure specified in the sampling plan. For 1000 tons of product, a grab sample is taken at a minimum of three randomly selected intervals. A minimum of three samples shall be taken even if the generated product is less than 1000 tons. Each time the belt is stopped to take a grab sample, templates, as shown in Figure 2, are placed a minimum of six inches apart to isolate the material on the belt. The material within the templates is removed with a small shovel or with a brush and dust pan for the finer material and is placed in an appropriate sized sampling container. Each of the grab samples shall be placed in the same sample container. This composited sample shall be crushed to produce a material with a nominal size of less than three eighths of an inch. Before crushing, the sample must be adequately dried. ASTM Method C-702-80, which is incorporated herein by reference, shall be used to reduce the size of the crushed grab sample to an one pint aliquot. The one pint aliquot shall be further crushed using a Braun mill or equivalent to produce a material which the majority of which shall be less than 200 Tyler mesh. An aliquot of the 200 mesh material shall be put into a labeled sealed container. The label must contain all the information listed in Section 6 (except item 4).

5.3 Serpentine Aggregate Covered Surfaces.

5.3.1 Serpentine Aggregate Covered Roads

A serpentine aggregate-covered road shall be characterized by taking grab samples from a minimum of three randomly chosen locations per mile of road. The method of randomly choosing the sampling locations is left up to sampling personnel but must follow the procedures specified in the sampling plan. A minimum of three samples shall be taken even if the road is less than one mile long. Section 4.3 describes some of the possible sampling apparatus used to collect the grab samples. Grab samples shall not contain underlying soils. Each of the grab samples shall be placed in the same sample container. This composited sample shall be crushed to produce material with a nominal size less than three-eighths of an inch. Before crushing, the sample must

be adequately dried. ASTM Method C-702-80 shall be used to reduce the size of the crushed grab sample to an one pint aliquot. The one pint aliquot shall be further crushed using a Braun mill or equivalent to produce a material which the majority shall be less than 200 Tyler mesh. An aliquot of the 200 mesh material shall be put into a labeled sealed container. The label must contain all the information listed in Section 6 (except item 4).

5.3.2 Serpentine Aggregate Covered Areas

A serpentine aggregate-covered play yard or parking lot shall be characterized by taking grab samples from a minimum of three randomly chosen locations per acre. The method of randomly choosing the sampling locations is left up to sampling personnel but must follow the procedure specified in the sampling plan. A minimum of three samples shall be taken even if the area is less than one acre. Section 4.3 describes some of the possible sampling apparatus for collecting the sample. Grab samples shall not contain underlying soils. Each of the grab samples shall be placed in the same sample container. This composited sample shall be crushed to produce a material with a nominal size of less than three-eighths of an inch. Before crushing, the sample must be adequately dried. ASTM Method C-702-80 shall be used to reduce the size of the crushed grab sample to a one pint aliquot. The one pint aliquot shall be further crushed using a Braun mill or equivalent to produce a material which the majority shall be less than 200 Tyler mesh. An aliquot of the 200 mesh material shall be put into a labeled sealed container. The label must contain all the information listed in Section 6 (except item 4).

5.3.3 Serpentine Aggregate Covered Road Shoulders

The sampling procedure specified in Section 5.3.1 or 5.3.2 shall be used for road shoulders covered with serpentine aggregate. The only difference is that a minimum of three grab samples shall be taken over a length of two miles of shoulder or over an area of two acres of shoulder surface. The word shoulder is meant to imply shoulders on both sides of the road. For serpentine aggregate covered shoulders, the sampling plan specified in Section 5 shall indicate whether the samples are collected on a two mile or two acre basis.

6.0 Sampling Log

A sample log must be kept showing:

1. A unique sample number.
2. Facility name.
3. Facility address or location where sample is taken.

4. A rough sketch, video tape, or photograph of the specific sampling locations.
5. Date and time of sampling.
6. Name of person performing sampling.

7.0 Analytical Procedure

7.1 Principle and Applicability

Samples of serpentine aggregate taken for asbestos identification are first examined for homogeneity and preliminary fiber identification at low magnification. Positive identification of suspect fibers is made by analysis of subsamples with the polarized light microscope.

The principles of optical mineralogy are well established.^{2,3} A light microscope equipped with two polarizing filters coupled with dispersion staining is used to observe specific optical characteristics of a sample. The use of plane polarized light allows the determination of refractive indices along specific crystallographic axes. Morphology and color are also observed. A retardation plate is placed in the polarized light path for determination of the sign of elongation using orthoscopic illumination. Orientation of the two filters such that their vibration planes are perpendicular (crossed polars) allows observation of the birefringence and extinction characteristics of anisotropic particles.

Quantitative analysis involves the use of point counting. Point counting is a standard technique in petrography for determining the relative areas occupied by separate minerals in thin sections of rock. Background information on the use of point counting³ and the interpretation of point count data⁴ is available.

This method is applicable to all bulk samples of serpentine aggregate submitted for identification and quantification of asbestos components.

7.2 Range

The analytical method may be used for analysis of samples containing from 0 to 100 percent asbestos. The upper detection limit is 100 percent. The lower detection limit is 0.25 percent.

7.3 Interferences

Fibrous organic and inorganic constituents of bulk samples may interfere with the identification and quantification of the asbestos content. Fine particles of other materials may also adhere to fibers to an extent sufficient to cause confusion in the identification.

7.4 Analytical Uncertainty

The uncertainty of the analytical method is two percent if twenty asbestos fibers are counted in a sample of 400 particles. The uncertainty of the analytical method may be assessed by a 95% confidence interval for the true percentage of asbestos fibers in the rock. The number of asbestos fibers in the sample is assumed to have a binomial distribution. If twenty asbestos fibers are found in a sample of 400 particles, a one-sided confidence interval for the true percentage has an upper bound of seven percent or an analytical uncertainty of two percent¹¹. The confidence interval used here is an "exact" interval computed directly from the binomial distribution.

7.5 Apparatus

7.5.1 Microscope

A low-power binocular microscope, preferably stereoscopic, is used to examine the bulk sample as received.

- * Microscope: binocular, 10-45X
- * Light Source: incandescent, fluorescent, halogen or fiber optic
 - * Forceps, Dissecting Needles, and Probes
 - * Glassine Paper, Clean Glass Plate, or Petri dish
 - * Compound microscope requirements: A polarized light microscope complete with polarizer, analyzer, port for wave retardation plate, 360° graduated rotating stage, substage condenser, lamp, and lamp iris.
 - * Polarized Light Microscope: described above
 - * Objective Lenses: 10X
 - * Dispersion Staining Objective Lens: 10X
 - * Ocular Lens: 10X
- * Eyepiece Reticule: 25 point or 100 point Chalkley Point Array or cross-hair
- * Compensator Plate: 550 millimicron retardation
- * First Order Red I Compensator, 530 nanometers

7.6 Reagents

Refractive Index Liquids: 1.490-1.570, 1.590-1.720 in increments of 0.002 or 0.004.

Refractive Index Liquids for Dispersion Staining: High-dispersion series, 1.550, 1.605, 1.630 (optional)

UICC Asbestos Reference Sample Set: Available from UICC MRC Pneumoconiosis Unit, Lisndough Hospital Penarth, Glamorgan CF6 1xw, UK and commercial distributors.

Tremolite-asbestos: Available from J. T. Baker

Actinolite-asbestos: Available from J. T. Baker

Chrysotile, Amosite, and Crocidolite is available from the National Institute of Standards and Technology.

Anthophyllite, Tremolite, Actinolite will be available from the National Institute of Standards and Technology during the first quarter of 1990.

8.0 Procedures

Exposure to airborne asbestos fibers is a health hazard. Bulk samples submitted for analysis are usually friable and may release fibers during handling or matrix reduction steps. All samples and slide preparations should be carried out in a ventilated hood or glove box with continuous airflow (negative pressure) exhausting through an HEPA filter. Handling of samples without these precautions may result in exposure of the analyst and contamination of samples by airborne fibers.

8.1 Sample Preparation

An aliquot of bulk material is removed from the one pint sample container. The aliquot is spread out on a glass slide. A drop of staining solution with appropriate refractive index is added to the aliquot. A cover slide is placed on top of the sample slide.

The first preparation should use the refractive index solution for Chrysotile. If during the identification phase other asbestiforms are suspected to be present in the sample, due to their morphology, then additional analyses shall be performed with the appropriate solutions. Report the percentages of each asbestiform and combine percentages to determine total asbestos concentrations.

8.2 Fiber Identification

Positive identification of asbestos requires the determination of the following optical properties:

Morphology (3 to 1 minimum aspect ratio)
Color and pleochroism
Refractive indices
Birefringence
Extinction characteristics
Sign of elongation

Table 3 lists the above properties for commercial asbestos fibers. Natural variations in the conditions under which deposits of asbestiform minerals are formed will occasionally produce exceptions to the published values and differences from the UICC standards. The sign of elongation is determined by use of the compensator plate and crossed polars. Refractive indices may be determined by the Becke line test. Becke line test or dispersion staining shall be used to identify asbestos fibers. Central stop dispersion staining colors are presented in Table 4. Available high-dispersion (HD) liquids should be used.

8.3 Quantification of Asbestos Content

Asbestos quantification is performed by a point-counting procedure. An ocular reticle (point array) or cross-hair is used to visually superimpose points on the microscope field of view.

The point counting rules are as follows:

1. Record the number of points positioned directly above each particle or fiber.
2. Record only one point if two points are positioned over same particle or fiber.
3. Record the number of points positioned on the edge of a particle or fiber.
4. If an asbestos fiber and a matrix particle overlap so that a point is superimposed on their visual intersection, a point is scored for both categories.
5. If a test point lies over an ambiguous structure, no particle or fiber is recorded. Examples of "ambiguous" structures are:
 - a. fibers whose dispersion colors are difficult to see
 - b. structures too small to categorize
6. A fiber mat or bundle is counted as one fiber.

For the purpose of the method, "asbestos fibers" are defined as mineral fibers having an aspect ratio greater than 3:1 and being positively identified as one of the minerals in Table 3.

A total of 400 points superimposed on either asbestos fibers or nonasbestos matrix material must be counted over at least eight different preparations of representative subsamples. Take eight forceps samples and mount each separately with the appropriate refractive index liquid. The preparation should not be heavily loaded. The sample should be uniformly dispersed to avoid overlapping particles and allow 25-50 percent empty area within the fields of view. Count 50 nonempty points on each preparation, using either

A reticle with 100 points (Chalkley Point Array) and counting 25 points in at least two randomly selected fields.

or

A reticle with 25 points (Chalkley Point Array) and counting at least two randomly selected fields.

or

A reticle with a standard cross-hair and counting at least 50 randomly selected fields.

For samples with mixtures of isotropic and anisotropic materials present, viewing the sample with slightly uncrossed polars or the addition of the compensator plate to the polarized light path will allow simultaneous discrimination of both particle types. Quantitation should be performed at 100X. Confirmation of the quantitation result by a second analyst on 10 percent of the analyzed samples should be used as standard quality control procedure. All optical properties in Section 8.2 shall be determined to positively identify asbestos.

EXCEPTION I

If the sample is suspected of containing no asbestos a visual technique can be used to report that the sample does not contain asbestos. The rules are as follows:

1. Prepare three slides as described in Section 8.3.
2. View 10 fields per preparation. Identify all fibers.
3. If all fibers are nonasbestos, report no asbestos were found and that the visual technique was used.

4. If one fiber is determined to be asbestos, discontinue the visual method and perform the point counting technique as described above.

EXCEPTION II

If the sample is suspected to have an asbestos content in excess of ten percent, a visual technique can be used to report that the sample contains greater than ten percent asbestos. The standard operating procedure of the visual technique allowed in the National Institute of Standards and Technology's National Voluntary Laboratory Accreditation Program, Bulk Asbestos Handbook, National Institute of Standards and Technology publication number NISTIR 88-3879 dated October 1988, which is incorporated herein by reference, shall be followed.

9.0 Calculations

The percent asbestos is calculated as follows:

% asbestos = (a/n) 100% where
a = number of asbestos counts,
n = number of nonempty points counted(400)
If a = 0, report "No asbestos detected"
If a > 0, report the calculated value to the nearest 0.25%
percent

If "no asbestos detected" is reported by the point counting technique, the analyst may report the observation of asbestos fibers in the non-counted portions of the sample.

10.0 Alternative Methods

10.1 Alternative Sampling Methods

Alternate sampling methods may be used as long as they are substantially equivalent to the sampling methods discussed in Section 5 and approved by the Executive Officer of the Air Resources Board. The ARB Executive Officer may require the submittal of test data or other information to demonstrate equivalency.

10.2 Analytical Methods

An alternative analytical method may be used as long as it produces results substantially equivalent to the results produced by the point counting method and approved by the Executive Officer of the Air Resources Board. The ARB Executive Officer may require the submittal of test data or other information to demonstrate equivalency.

11.0References

1. G. S. Koch, Jr., R. F. Link, *Statistical Analysis of Geological Data*, New York, Dover Publications, Inc., December 1985.
2. Paul F. Kerr, *Optical Mineralogy*, 4th ed., New York, McGraw-Hill, 1977.
3. E. M. Chamot and C. W. Mason, *Handbook of Chemical Microscopy*, Volume One, 3rd ed., New York: John Wiley & Sons, 1958
4. F. Chayes, *Petrographic Model Analysis: An Elementary Statistical Appraisal*, New York: John Wiley & Sons, 1958.

5. E.P. Brantly, Jr., K. W. Gold, I. E. Myers, and D. E. Lentzen, Bulk Sample Analysis for Asbestos Content: Evaluation of the Tentative Method, U.S. Environmental Protection Agency, October 1981.
6. U.S. Environmental Protection Agency, Asbestos-Containing Materials in School Buildings: A Guidance Document, Parts 1 and 2 EPA/OTS No. C00090m Narcg 1979.
7. D. Lucas, T. Harwell, and A. V. Rao, Asbestos Containing Materials in School Buildings: Guidance for Asbestos Analytical Programs, EPA 580/13-80-017a, U. S. Environmental Protection Agency, December 1980.
8. D.H. Taylor and J.S. Bloom, Hexametaphosphate Pretreatment of Insulation Samples For Identification of Fibrous Constituents, Microscope, 28, 1980.
9. W. J. Campbell, R. L. Blake, L. L. Brown, E. E. Cather, and J. J. Sjoberg. Selected Silicate Minerals and Their Asbestiform Varieties: Mineralogical Definitions and Identification-Characterization, U. S. Bureau of Mines Information Circular 8751, 1977.
10. Walter C. McCrone, Asbestos Particle Atlas, Ann Arbor, Ann Arbor Science Publishers, June 1980.
11. John Moore, Biostatistician, Personnel Communication, February 8, 1990.

Figure 1
Thin Wall Tube for Sampling

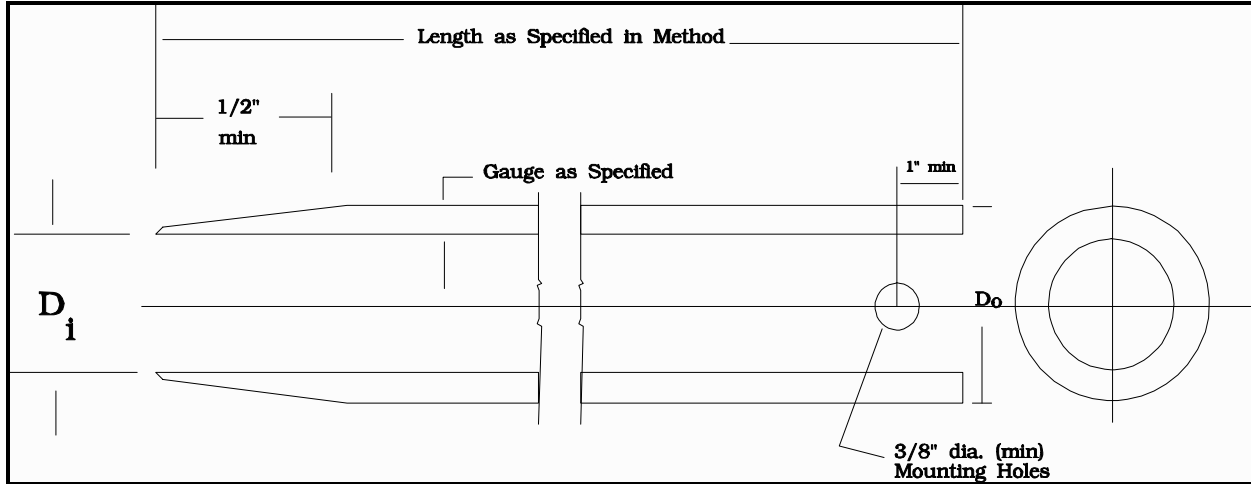

Note 1 Minimum of two mounting holes on opposite sides for 2 to 3 inch diameter sampler.

Note 2 Minimum of four mounting holes spaced at 90° for samplers 4 inch diameter and larger.

Note 3 Tube held with hardened screws.

Note 4 Two inch outside-diameter tubes are specified with an 18-gauge wall thickness to comply with area ratio criteria accepted for "undisturbed samples." Users are advised that such tubing is difficult to locate and can be extremely expensive in small quantities. Sixteen-gauge tubes are generally readily available.

Table 1

Suitable Thin Walled Steel Sample Tube^A

Outside diameter:			
inches	2	3	5
millimeters	50.8	76.2	127
Wall thickness:			
Bwg	18	16	11
inches	0.049	0.065	0.120
millimeters	1.24	1.65	3.05
Tube length:			
inches	36	36	54
meters	0.91	0.91	1.45
Clearance ratio, %	1	1	1

^A The three diameters recommended in Table 1 are indicated for purposes of standardization, and are not intended to indicate that sampling tubes of intermediate or larger diameters are not acceptable. Lengths of tubes shown are illustrative. Proper lengths to be determined as suited to field conditions.

Table 2

Dimensional Tolerances for Thin Walled Tubes

Nominal Tube Diameters from Table 1 ^A Tolerances, inches			
Size Outside	2	3	4
	Diameter		

Outside diameter	+0.007	+0.010	+0.015
	-0.000	-0.000	-0.000
Inside diameter	+0.000	+0.000	+0.000
	-0.007	-0.010	-0.015
Wall thickness	+0.007	+0.010	+0.015
Ovality	0.015	0.020	0.030
Straightness	0.030/ft	0.030/ft	0.030/ft

^AIntermediate or larger diameters should be proportional.

Tolerances shown are essentially standard commercial manufacturing tolerances for seamless steel mechanical tubing. Specify only two of the first three tolerances; O.D. and I.D. or O.D. and Wall, or I.D. and Wall.

Figure 2

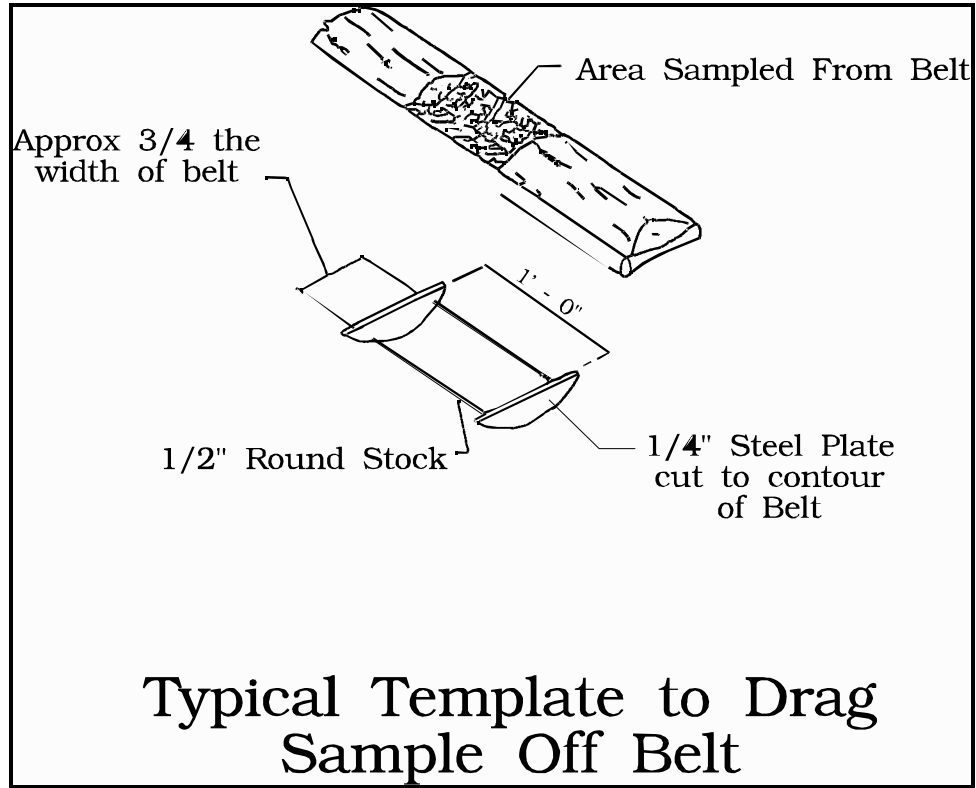

Table 3
Optical Properties of Asbestos Fibers

Mineral Sign of Extinction	Morphology, color Elongation	Refractive Indices ^b		Birefringence
		alpha	gamma	
Chrysotile fiber + (asbestiform (length slow) serpentine)	Wavy fibers. fiber bundles have splayed ends and "kinks" Aspect ratio typically > 10:1. Colorless, nonpleochroic.	1.493-1.560	1.517-1.562 ^f (normally 1.556)	.002-.014 to length
Amosite fiber + 1.696-1.710)	Straight, rigid fibers. (asbestiform Aspect ratio typically >10:1. (length slow) grunerite) Colorless to brown, nonpleo- chroic or weakly so. Opaque inclusions may be present.	1.635-1.696	1.655-1.729 ^f	.020-0.33 (normally to
Crocidolite fiber - (asbestiform (length fast) riebeckite)	Straight, rigid fibers. Thick fibers and bundles com- mon, blue to purple-blue in color. Pleochroic. Bire- fringence is generally masked by blue color.	1.654-1.701	1.668-1.717 (normally close to 1.700	.014-0.016 to length
Anthophyllite- fiber + asbestos (length slow)	Straight fibers and fiber bundles showing splayed ends. Colorless to light brown. Pleochroism absent.	1.596-1.652	1.615-1.676 ^f	.019-.024 to length

Tremolite- fiber + actinolite- (length slow) asbestos	1.599-1.668	1.622-1.688 ^f	.023-.020	to length
---	-------------	--------------------------	-----------	--------------

Straight and curved fibers and
fiber bundles. Large bundles
show splayed ends. Tremolite is
Colorless and actinolite is green
weakly to moderately pleochroic.

-
- a From References 6; colors cited are seen by observation with plane polarized light.
b From References 7 and 9.
c Fibers subjected to heating may be brownish.
d fibers defined as having aspect ratio >3:1.
e to fiber length.
f || to fiber length.

Table 4
Central Stop Dispersion Staining Colors^a

Mineral	RI Liquid	nu	nu
Chrysotile magenta	1.550HD	Blue	blue-
Amosite Yellow	1.680	blue-magenta to pale blue	Golden-
	1.550HD	Yellow to white	Yellow to
white			
Crocidolite ^b magenta	1.700	Red magenta	Blue-
	1.550HD	Yellow to white	Yellow to white
Anthophyllite	1.605HD	Blue	Gold to Gold-
magenta			
Tremolite	1.605HD ^c	Pale blue	Yellow
Actinolite	1.630HD	Gold-magenta to blue	Gold
yellow	1.630HD ^c	Magenta	Golden-

a From Reference 10.
b Blue absorption color.
c Oblique extinction view.