

United States
Environmental Protection
Agency

Office of Air Quality
Planning And Standards
Research Triangle Park, NC 27711

EPA-450/4-84-007h
March 1984

AIR



LOCATING AND ESTIMATING AIR EMISSIONS FROM SOURCES OF MANGANESE



EPA-450/4-84-007h
September 1985

Locating and Estimating Air Emissions From Sources of Manganese

U.S. ENVIRONMENTAL PROTECTION AGENCY
Office of Air and Radiation
Office of Air Quality Planning and Standards
Research Triangle Park, North Carolina 27711

September 1985

This report has been reviewed by the Office of Air Quality Planning and Standards, U.S. Environmental Protection Agency, and approved for publication as received from the contractor. Approval does not signify that the contents necessarily reflect the views and policies of the Agency, neither does mention of trade names or commercial products constitute endorsement or recommendation for use.

EPA-450/4-84-007h

CONTENTS

	<u>Page</u>
1. Purpose of Document	1-1
2. Overview of Document Contents	2-1
3. Background	3-1
3.1 Manganese Characteristics	3-1
3.2 Overview of Manganese Production	3-3
3.3 Overview of End Uses of Manganese	3-10
4. Manganese Emissions From Production and Use of Manganese	4-1
4.1 Manganese Ore Beneficiation, Transport, and Storage	4-2
4.2 Production of Manganese-Bearing Alloys	4-3
4.3 Production of Manganese Metal and Synthetic Manganese Oxide	4-14
4.4 Production of Manganese Chemicals	4-21
4.5 Iron and Steel Production	4-25
4.6 Iron and Steel Foundries	4-53
4.7 Battery Manufacturing	4-58
5. Indirect Sources of Manganese	5-1
5.1 Coal and Oil Combustion	5-1
5.2 Cement Production	5-7
5.3 Municipal Refuse and Sewage Sludge Incineration	5-12
5.4 Manganese Fuel Additives	5-20
6. Source Test Procedures	6-1
6.1 Literature Review of Sampling Methods	6-1
6.2 Literature Review of Analytical Procedures	6-1

FIGURES

<u>Number</u>		<u>Page</u>
3-1	End Use of Manganese and Manganese Compounds	3-11
4-1	Flow Chart of Manganese-Bearing Ferroalloys Production by Electric Arc Furnace Process	4-5
4-2	Open Furnace	4-7
4-3	Semisealed Furnace	4-7
4-4	Sealed Furnace	4-7
4-5	Generalized Flow Diagrams for Chemical MnO ₂ Production	4-16
4-6	Electrolytic MnO ₂ Production From MnO ₂ Ores and Rhodochrosite Ores	4-18
4-7	Production of KMnO ₄ Roasting and Liquid-Phase Oxidation Processes	4-23
4-8	Cross-Sectional View of a Typical Blast Furnace	4-29
4-9	Schematic Flow Diagram of a Typical Sinter Plant	4-35
4-10	Schematic Representation of an Open Hearth Furnace	4-39
4-11	Basic Oxygen Process Furnace	4-42
4-12	Schematic of Electric Arc Furnace Process	4-48
4-13	Generalized Flow Diagram of Iron/Steel Foundry	4-54
5-1	Basic Process Flow Diagram for Wet and Dry Cement Production	5-8
5-2	Basic Configuration of a Municipal Refuse Incinerator	5-13
5-3	Schematic of a Typical Multiple-Hearth Incineration System	5-15

FIGURES (continued)

<u>Number</u>		<u>Page</u>
5-4	Schematic of a Fluidized-Bed Sewage Sludge Incinerator	5-16
5-5	Schematic of a Typical Municipal Rotary-Kiln Incineration Facility	5-17
6-1	Schematic of Method 5 Sampling Train	6-2

TABLES

<u>Number</u>	<u>Page</u>
3-1 Physical Properties of Metallic Manganese	3-2
3-2 Physical Properties of Selected Manganese Compounds	3-4
3-3 Common Manganese-Containing Minerals	3-7
3-4 Domestic Manganese Ore Production, Imports, and Exports	3-7
3-5 Consumption of Manganese Ores in the United States	3-12
3-6 U.S. Consumption of Manganese Ferroalloys According to End Use in 1981	3-12
3-7 Primary Nonmetallurgical Uses of Manganese Oxides	3-14
3-8 Primary Uses of Manganese Compounds	3-16
3-9 Principal Uses of Potassium Permanganate	3-17
4-1 Specifications and Typical Compositions of Manganese Ferroalloys	4-4
4-2 Manganese Emission Factors for Processing of Raw Materials at Manganese-Bearing Ferroalloy Production Facilities	4-11
4-3 Manganese Emission Factors for Finishing Operations	4-11
4-4 Manganese Emission Factors for Submerged-Arc Electric Furnaces Producing Ferromanganese and Silicomanganese	4-12
4-5 Characterization of Particulate Emissions from Ferroalloy Furnaces	4-13
4-6 Domestic Producers of Manganese Ferroalloys, 1980	4-13
4-7 Derived Manganese Emissions for Synthetic Manganese Production	4-19
4-8 Domestic Producers of Manganese Metal and Synthetic Manganese Dioxide	4-20

(continued)

TABLES (continued)

<u>Number</u>	<u>Page</u>
4-9 Manganese Emission Factors for the Manufacture of Manganese Chemicals	4-24
4-10 Domestic Producers of Manganese Chemicals	4-26
4-11 Manganese Emissions from Iron Blast Furnaces	4-31
4-12 Manganese Content of Raw Materials and Byproducts of Blast Furnace Production	4-31
4-13 Locations (By State and City) of Blast Furnaces in the United States	4-33
4-14 Manganese Emission Factors for Sintering Operations	4-36
4-15 Locations (By State and City) of Sinter Plants in the U.S. Integrated Steel Industry	4-38
4-16 Manganese Emissions Factors for Open-Hearth Furnace Operations	4-40
4-17 Locations (By State and City) of Steel Plants With Open-Hearth Furnaces in the United States	4-41
4-18 Manganese Content of Raw Materials and Products of BOF Process	4-44
4-19 Manganese Emission Factors for Basic Oxygen Furnace Operations	4-45
4-20 Locations (By State and City) of Basic Oxygen Furnaces in the Iron and Steel Industry in the United States	4-46
4-21 Manganese Emission Factors for Electric Arc Furnace Operations	4-50
4-22 Alphabetical Listing (By Company Name) of Electric Arc Furnace/Locations in the United States	4-51
4-23 Manganese Emission Factors for Iron Foundries	4-57
4-24 Manganese Emission Factors for Steel Foundries	4-57
4-25 Manganese Emission Factors for Battery Manufacture	4-60

(continued)

TABLES (continued)

<u>Number</u>	<u>Page</u>
5-1 Manganese Concentrations in U.S. Coals	5-2
5-2 Manganese Concentrations in U.S. Crude Oils	5-2
5-3 Particle Size Distribution of Manganese in Fly Ash From Coal Combustion	5-3
5-4 Manganese Particulate Collection Efficiencies of Various Types of Control Devices	5-3
5-5 Emission Factors for Manganese From Coal and Oil Combustion: Utility Boilers (>264 GJ/h Input)	5-5
5-6 Emission Factors for Manganese from Coal and Oil Combustion: Industrial Boilers (>26 GJ/h Input)	5-6
5-7 Emission Factors for Manganese From Coal and Oil Combustion: Commercial/Institutional Boilers (>26 GJ/h Input)	5-6
5-8 Emission Factors for Manganese from Coal and Oil Combustion: Residential Boilers (<422 MJ/h Input)	5-7
5-9 Manganese Emission Factors for Cement Plants	5-10
5-10 Location of Cement Plants in the United States	5-11
5-11 Manganese Concentrations in Municipal Refuse and Sewage Sludges	5-12
5-12 Emissions Factors for Manganese From Municipal Refuse and Sewage Sludge Incinerators	5-18
5-13 Population of Municipal Refuse and Sewage Sludge Incinera- tors in the United States, 1978	5-19

SECTION 1
PURPOSE OF DOCUMENT

The U.S. Environmental Protection Agency (EPA), States, and local air pollution control agencies are becoming increasingly aware of the presence of substances in the ambient air that may be toxic at certain concentrations. This awareness, in turn, has led to attempts to identify source/receptor relationships for these substances and to develop control programs to regulate emissions. Unfortunately, very little information is available on the ambient air concentrations of many of these substances or on the sources that may be discharging them to the atmosphere.

To assist groups interested in inventorying air emissions of various potentially toxic substances, EPA is preparing a series of documents such as this that compiles available information on sources and emissions of these substances. This document specifically deals with manganese and manganese compounds. Its intended audience includes Federal, State, and local air pollution personnel and others who are interested in locating potential emitters of manganese and making gross estimates of air emissions therefrom.

Because of the limited amounts of data available on manganese emissions, and since the configuration of many sources will not be the same as those described herein, this document is best used as a primer to inform air pollution personnel about (1) the types of sources that may emit manganese, (2) process variations and release points that may be expected within these sources, and (3) available emissions information indicating the potential for manganese or manganese compounds to be released into the air from each operation.

The reader is strongly cautioned that the emissions information contained in this document will not yield an exact assessment of emissions from any particular facility. Since insufficient data are available to develop statistical estimates of the accuracy of these

emission factors, no estimate can be made of the error that could result when these factors are used to calculate emissions for any given facility. It is possible, in some extreme cases, that orders-of-magnitude differences could result between actual and calculated emissions, depending on differences in source configurations, control equipment, and operating practices. Thus, in situations where an accurate assessment of manganese emissions is necessary, source-specific information should be obtained to confirm the particular operations, the types and effectiveness of control measures, and the impact of operating practices. A source test and/or material balance should be considered as the best means to determine air emissions directly from an operation.

SECTION 2
OVERVIEW OF DOCUMENT CONTENTS

As noted in Section 1, the purpose of this document is to assist Federal, State, and local air pollution agencies and others who are interested in locating potential air emitters of manganese and manganese compounds and making gross estimates of air emissions therefrom. Because of the limited background data available, the information summarized in this document does not and should not be assumed to represent the source configuration or emissions associated with any particular facility.

This section provides an overview of the contents of this document. It briefly outlines the nature, extent, and format of the material presented in the remaining sections of this report.

Section 3 of this document provides a brief summary of the physical and chemical characteristics of manganese, its commonly occurring forms, and an overview of its production and uses. A table summarizes the quantities of manganese consumed in various end uses in the United States. This background section may be useful to someone who needs to develop a general perspective on the nature of the substance and where it is manufactured and consumed.

The fourth section of this document focuses on major industrial source categories that may discharge manganese-containing air emissions. Section 4 discusses the production of manganese and manganese compounds, the use of manganese in ferroalloys, and the discharge of manganese from industrial sources due to its being a trace contaminant in fossil fuels. For each major industrial source category described in Section 4, example process descriptions and flow diagrams are given, potential emission points are identified, and available emission factor estimates are presented that show the potential for manganese emissions before and after controls employed by industry. Individual companies are named that are reported to be involved with either the production and/or use of manganese and manganese compounds based on industry contacts and available trade publications.

The sources of all emission factors presented in this report have been cited, and the reader is referred to these sources for discussions concerning the basis and limitations of these estimates. Because most of the emission factors have been developed for materials that contain manganese, the manganese emissions will depend both on the amount of material emitted and the manganese content of the material. For example, in a foundry operation that produces a casting that is 5 percent manganese, the manganese emissions would amount to 5 percent of the total emissions. If the same operation with the same total emissions were to produce a casting with 2.5 percent manganese, the manganese emissions associated with the furnace castings would be cut in half. Because few plants produce only one product, this is a significant consideration.

The final section of this document summarizes available procedures for source sampling and analysis of manganese. Details are not prescribed, nor is any EPA endorsement given or implied to any of these sampling and analysis procedures. At this time, EPA has generally not evaluated these methods. Consequently, this document merely provides an overview of applicable source sampling procedures and references for those interested in conducting source tests.

This document does not contain any discussions of health or other environmental effects of manganese or manganese compounds, nor does it include any discussion of ambient air levels or ambient air monitoring techniques.

Comments on the contents or usefulness of this document are welcomed, as is any information on process descriptions, operating practices, control measures, and emissions that would enable EPA to improve its contents. All comments should be sent to:

Chief, Source Analysis Section (MD-14)
Air Management Technology Branch
U.S. Environmental Protection Agency
Research Triangle Park, North Carolina 27711

SECTION 3 BACKGROUND

3.1 MANGANESE CHARACTERISTICS

Manganese (Mn) is a hard, brittle, grayish-white metal widely distributed in the Earth's rocks. A transition element whose properties fall between those of chromium and iron, manganese has an atomic number of 25 and an atomic weight of 54.938. Manganese-55 is the only stable isotope.¹ Manganese can exist in several different crystalline forms of complex structure. These forms are stable below 1100°C and are usually brittle and unworkable. Manganese constitutes 0.1 percent of the Earth's crust and ranks twelfth in abundance among the elements found there. Of the most commonly known metals, only aluminum, iron, magnesium, and titanium are more abundant. Although manganese just precedes iron in the periodic table, it is not ferromagnetic like iron; however, some of its alloys and compounds are. Manganese compounds can have various valences, but manganese is divalent in the most stable salts, and manganese dioxide (MnO₂) is the most stable oxide.² Table 3-1 presents the physical constants and properties of manganese.

Manganese is ubiquitous in the Earth's crust and water bodies. In most soils, concentrations range from 200 to 300 ppm; in many rocks, concentrations range from 800 to 1400 ppm; and in some sedimentary rocks, concentrations can range from 6000 to 8000 ppm.¹ Seawater contains a few parts per billion, and concentrations increase at greater depths. Manganese oxide nodules have been found on large areas of the ocean floor; some analyzed deposits have shown an average manganese content of 24.2 percent.² Concentrations in fresh water can range from a few parts per billion to several parts per million. Atmospheric precipitation also contains manganese--around 0.012 ppm--primarily introduced through air pollution.²

TABLE 3-1. PHYSICAL PROPERTIES OF METALLIC MANGANESE^a

Property	Value
Atomic number	25
Atomic weight	54.938
Crystal structure	Cubic or tetragonal
Valence state	-3, 1, 2, 3, 4, 5, 6, and 7
Melting point, °C	1244± 3°C
Boiling point, °C	1962
Specific Gravity	7.21 to 7.44 (depending on the allotropic form)
Specific heat at 25.2°C, J/g	0.48
Linear coefficient of thermal expansion x 10 ⁻⁶ per °C at 0-100°C range	22.8
Hardness, Mohs scale	5
Compressibility	8.4 x 10 ⁻⁷
Solidification shrinkage, %	1.7
Standard electrode potential	1.134
Magnetic susceptibility, m ³ /kg	1.21 x 10 ⁻⁷
Latent heat of fusion, J/g	244
Latent heat of vaporization, J/g	4020
Solubility	Decomposes in water; is soluble in slightly dilute acid

^a Sources: References 1 and 3

The most important valence states of manganese are +2, +4, and +7, as exhibited in manganese oxide (MnO), manganese dioxide (MnO_2), and permanganate (MnO_4^-), respectively. Thus, oxide manganese ores can serve as sources of active oxygen, the degree of activity varying with the type of ore and compound. Table 3-2 presents the physical properties of selected manganese compounds.

Ores are generally classified according to their manganese content as follows: ores containing more than 35 percent Mn are classed as manganese ores; those containing 10 to 35 percent, as ferruginous manganese ores; and those containing 5 to 10 percent Mn, as manganiferrous ores. None of the U.S. ores contain more than 35 percent Mn; most of the high-quality ores and ferroalloys are imported. Because manganese is considered a strategic material, the Government has maintained stockpiles since 1916. Table 3-3 lists the common manganese-bearing minerals, and Table 3-4 presents production, import, and export data.

3.2 OVERVIEW OF MANGANESE PRODUCTION

The different methods used in the production of the various manganese products are briefly described in this subsection. More detail is presented in Section 4.

3.2.1 Production of Ferroalloys

High-carbon ferromanganese (or standard ferromanganese), which contains up to 7.5 percent carbon, is used in larger quantities (primarily by the steel industry) than any other form of manganese. Until 1978, U.S. high-carbon ferromanganese was produced primarily in blast furnaces similar to those used to smelt iron ore. Now it is produced primarily in submerged-arc electric furnaces. The furnace charge consists of a mixture of Mn ores, coke, and some flux. Recovery of Mn in the alloy ranges from 70 to 80 percent.¹ In some cases, the slag from this process also is used to produce silicomanganese for use in the manufacture of low-carbon steel. The manganese content of this slag ranges from 30 to 42 percent.

TABLE 3-2. PHYSICAL PROPERTIES OF SELECTED MANGANESE COMPOUNDS^a

Compound	Formula	Oxidation State	Appearance	Density g/cm ³	Melting point, °C	Boiling point, °C	Solubility
Dimanganese	Mn ₂ (CO) ₁₀	0	Golden-yellow crystals	1.75	154-155°		Insoluble in H ₂ O; soluble in most organic solvents
Methylcyclopentadienylmanganese tricarbonyl	C ₅ H ₇ Mn(CO) ₃	+1	Light-amber liquid	1.39	1.5°	233	Insoluble in H ₂ O; soluble in most organic solvents
Manganese acetate tetrahydrate	Mn(C ₂ H ₃ O ₂) ₂ •4H ₂ O	+2	Pale-red crystals	1.589			Slightly soluble in H ₂ O; soluble in ethanol and methanol
Manganese borate	MnB ₄ O ₇ •8H ₂ O	+2	White to pale red solid				Insoluble in H ₂ O, ethanol, and soluble dilute acids
Manganese carbonate (rhodochrosite)	MnCO ₃	+2	Pink solid	3.125	Decomposes at >200°		Soluble product H ₂ O:8.2 x 10 ⁻¹¹ ; soluble in dilute acids
Manganese chloride	MnC ₁₂	+2	Pink crystal solid	2.977	652°	1190	Soluble in H ₂ O, soluble pyridine, ethanol, insoluble ether
Manganese hydroxide (pyrochroite)	Mn(OH) ₂	+2	White to pink	3.26	Decomposes at 140°		Soluble in acid; soluble base at higher temperatures
Manganese nitrate hexahydrate	Mn(NO ₃) ₂ •6H ₂ O	+2	Colorless to slightly pink crystals	1.81	25.8°	Decomposes	Soluble in H ₂ O, soluble ethanol
Manganese (II) oxide (manganosite) ^b	MnO	+2	Green	5.37	1945°		Insoluble in H ₂ O
Manganese sulfate	MnSO ₄	+2	Almost-white crystals solid	3.25	Decomposes 850°		Soluble in 52 g/100 g H ₂ O; slightly soluble in methanol; insoluble in ether
Manganese dihydrogen phosphate dihydrate	Mn(H ₂ PO ₄) ₂ •2H ₂ O	+2	Almost colorless crystal solid; four-sided prisms		-H ₂ O, 100°		Soluble in H ₂ O; insoluble in ethanol; diliquescent
Trimanganese tetraoxide alpha phase (Hausmannite)	Mn ₃ O ₄	+2, +3	Black crystals with metallic sheen	4.84	1560°		Insoluble in H ₂ O
Manganese (III) acetate dihydrate	Mn(C ₂ H ₃ O ₂) ₃ •2H ₂ O	+3	Cinnamon-brown crystal solid				Decomposes in H ₂ O
Manganese (III) acetylacetonate	Mn(C ₅ H ₇ O ₂) ₃	+3	Brown to black crystal		172		Insoluble in H ₂ O, soluble in organic solvent
Manganese (III) fluoride	MnF ₃	+3	Red crystals	3.54	Decomposes (stable to 600°)		Decomposes in H ₂ O
Manganese (III) oxide "	Mn ₂ O ₃	+3	Black to brown solid	4.89	871-887° decomposes		Insoluble in H ₂ O

Table 3-2 (continued)

Compound	Formula	Oxidation State	Appearance	Density g/cm ³	Melting point, °C	Boiling point, °C	Solubility
Manganese (III) oxide m , hydrated	MnO(OH)	+3	Black solid	4.2-4.4	Decomposes at 250° to gamma Mn ₂ O ₃		Insoluble in H ₂ O; dissociates in dilute acids
Pentamanganooxide	Mn ₅ O ₈	+2, +4	Black solid	4.85	Decomposes at 550° to alpha Mn ₂ O ₃		Insoluble in H ₂ O
Manganese (IV) oxide S , pyrolusite	MnO ₂	+4	Black to gray crystal solid	5.118	Decomposes at 500-600°		Insoluble in H ₂ O
Potassium manganate (IV)	K ₂ MnO ₃	+4	Black microscopic crystals	3.071	1100°		Decomposes in H ₂ O dissociates
Barium manganate (V)	Ba ₃ (MnO ₄) ₂	+5	Emerald-green crystals	5.25	Decomposes at 960°		Insoluble in H ₂ O
Potassium manganate (I)	K ₃ MnO ₄	+5	Turquoise-blue microscopic crystals	2.78	Decomposes at 800-1100°		Soluble in H ₂ O; decomposes; is hygroscopic; soluble in 40% KOH at -15 °C
Sodium manganate (V)	Na ₃ MnO ₄	+5	Bluish, dark-green microscopic crystals		Decomposes at 1250°		Soluble in H ₂ O; decomposes; is hygroscopic;
Barium manganate (VI)	BaMnO ₄	+6	Small green to black crystals	5.20	Decomposes at 1150°		Insoluble in H ₂ O; soluble product 2.46 x 10 ⁻¹⁰
Potassium manganate (II)	K ₂ MnO ₄	+6	Dark-green to black needles	2.80	Decomposes at 600°		Soluble in H ₂ O; decomposes;
Sodium manganate (VI)	Na ₂ MnO ₄	+6	Small dark-green needles		Decomposes at 300°		Soluble in H ₂ O; decomposes;
Potassium manganate (VI), permanganate (VII), double salt	K ₃ (MnO ₄) ₂ or K ₂ MnO ₄ •K ₂ MnO ₄	+6, +7	Dark, small hexagonal plates				Soluble in H ₂ O; decomposes;
Manganese heptoxide	Mn ₂ O ₇	+7	Dark-red oil	2.396	5.9, decomposes at 55°		Soluble in H ₂ O; is hydroscopic

Table 3-2 (continued)

Compound	Formula	Oxidation State	Appearance	Density g/cm ³	Melting point, °C	Boiling point, °C	Solubility
Ammonium Permanganate	NH ₄ MnO ₄	+7	Dark purple, rhombic, bipyramidal, needles	2.22	Decomposes at >70°		8 g/100 g H ₂ O at 15 °C (86f g/kuter at 25 °C)
Barium permanganate	Ba(MnO ₄) ₂	+7	Dark purple crystals	3.77	Decomposes at 95-100°		72.4 g/100 g H ₂ O at 25 H ₂ O
Calcium permanganate tetrahydrate	Ca(MnO ₄) ₂ •4H ₂ O	+7	Black crystals; solutions look purple	About 2.49	Decomposes at 130-140°		388 g/100 g H ₂ O at 25 °C; deliquescent
Cesium permanganate	CsMnO ₄	+7	Dark purple rhombic, bipyramidal prisms or needles	3.60	Decomposes at 250°		0.23 g/100 g H ₂ O at 20 °C
Lithium permanganate	Li(MnO ₄)•3H ₂ O	+7	Long, dark purple needles	2.06	Decomposes at 104°-107°		71 g/100 g H ₂ O at 16 °C
Magnesium permanganate hexahydrate	Mg(MnO ₄) ₂ •6H ₂ O	+7	Bluish-gray crystals	2.18	Decomposes at 130°		Soluble in H ₂ O, CH ₃ OH, pyridine, and glacial acetic acid
Potassium permanganate	KMnO ₄	+7	Dark purple, bipyramidal, rhombic prisms	2.703			Soluble in H ₂ O, acetic acid, trifluoroacetic acid, acetic anhydride, acetone, pyridine, benzonitrile, and sulfolane
Rubidium permanganate	RbMnO ₄	+7	Dark purple, rhombic bipyramidal, prisms	3.23	Decomposes at 250°		1.1 g/100 g H ₂ O at 19 °C
Silver permanganate	AgMnO ₄	+7	Dark purple	4.27	Decomposes at 110°		0.92 g/100 g H ₂ O at 20 °C
Sodium permanganate	AgMnO ₄	+7	Dark purple crystals	1.972	36.0		Soluble in H ₂ O; deliquescent
Zinc permanganate hexahydrate	Zn(MnO ₄) ₂ •6H ₂ O	+7	Black crystal; solutions look purple	2.45	Decomposes at 90°-105°		Soluble in H ₂ O; deliquescent

^a Source: Reference 1.

^b Roman numerals indicate valence number.

TABLE 3-3. COMMON MANGANESE CONTAINING MINERALS^a

Mineral	Composition	Weight percent Mn
Bementite	$Mn_8Si_6O_{15}(OH)_{10}$	43.2
Braunite	$Mn_2Mn_6SiO_{12}$	66.6
Cryptomelane	KMn_8O_{16}	59.8
Franklinite	$(Fe, Zn, Mn)O \cdot (Fe, Mn)_2O_3$ ^b	10-20
Hausmannite	Mn_3O_4	72.0
Manganite	$Mn_2O_3 \cdot H_2O$	62.5
Manganoan calcite	$(Ca, Mn)CO_3$	35.4
Psilomelane	$(Ba, Mn)Mn_8O_{16}(OH)_4$ ^b	51.7
Pyrolusite	MnO_2	63.2
Rhodochrosite	$MnCO_3$	47.8
Rhodonite	$MnSiO_3$	41.9
Wad	Hydrous mixture of oxides	Variable

^a Source: Reference 1.

^b Manganese appears in different oxidation states in these minerals.

TABLE 3-4. DOMESTIC MANGANESE ORE PRODUCTION, IMPORTS, AND EXPORTS^a
(1000 tons)

	1981	1982	1983	1984
Domestic mine ore production ^b	0	0	0	0
Imports, manganese ore	639	238	368	410
Imports, ferromanganese	671	493	342	500
Exports, manganese ore	65	29	19	140
Exports, ferromanganese	15	10	8	6

^a Source: Reference 4.

^b Excludes manganiferous ore containing less than 35 percent manganese, which accounts for about 2 percent or less of apparent consumption of manganese.

Silicomanganese, a ferroalloy containing 12.5 to 18.5 percent silicon (Si) and 65 to 68 percent Mn, is added to steel when both silicon and manganese are required. The electric arc smelting process by which it is produced is similar to that used to produce high-carbon ferromanganese, but the charge contains large amounts of quartz and, sometimes, the high-Mn slag from the high-carbon ferromanganese process (as mentioned earlier). The carbon content of this alloy is 2 percent.

Ferromanganese silicon (28 to 32 percent Si and 06 percent carbon) is normally made in a two-step process. Regular silicomanganese (with 16 to 18 percent Si and 2 percent carbon) is made in the first step, and this product is then charged (in solid form) to an electric arc furnace along with quartz and coal or coke. In this slagless process, the quartz is reduced to Si and displaces the carbon in the remelted silicomanganese.¹

Refined ferromanganese alloys (which are not carbon-saturated and have a carbon content of 0.1 to 1.5 percent) are usually made by the reaction of Si with Mn ore and lime.¹

A process recently developed and used by the Elkem Metals Company involves the production of medium-carbon ferromanganese by the oxygen refining of high-carbon ferromanganese in a special furnace.^{1,5}

3.2.2 Production of Manganese Metals

Manganese is recovered from aqueous solutions by means of electrolysis. The manganese produced by this method is 99.5 percent pure. In this process, manganese ores are roasted to reduce higher oxides to MnO, which is acid-soluble. After the various impurities are removed, the solution is electrolyzed in a diaphragm cell. The Mn deposited on the cathode is thin and brittle and sulfur is the primary impurity. Hydrogen is removed by heating the Mn flakes to 500°C. Nitrogen-bearing electrolytic Mn containing 6 to 7 percent N₂ is also produced by heating the Mn flakes up to 900°C in an atmosphere of N₂.¹

Another process (developed and used by Chemetals Corporation) is fused salt electrolysis. The feed, which is a Mn ore that has been reduced, is charged to an electrolytic cell containing molten calcium fluoride and lime. The cell is operated at 1300°C, and the molten Mn is cast into cast iron pots. The metal produced by this process contains 92 to 98 percent Mn, and the main impurity is iron.

3.2.3 Production of Manganese (II) Oxide

Manganese (II) oxide is an important precursor of many commercial manganese compounds. It is made by reductive roasting of Mn ores. In one process, crushed Mn ore is processed in a countercurrent reactor by using a reducing gas (e.g., CH_4 and air). The MnO that is formed is cooled in an inert atmosphere, and then ground to -200 mesh.¹ Other processes use a rotary kiln in the reduction step.

3.2.4 Production of Synthetic Manganese Dioxide

Synthetic manganese dioxide is produced by both chemical and electrolytic methods. Chemical manganese dioxide (CMD) is produced either by the chemical reduction of permanganate (Type 1), or by thermally decomposing manganese salts, such as MnCO_3 or $\text{Mn}(\text{NO}_3)_2$, under oxidizing conditions, followed (if necessary) by oxidation in the liquid phase (Type 2).¹

Electrolytic manganese dioxide (EMD) is produced by electrolysis of MnSO_4 solution. The MnSO_4 is prepared from rhodochrosite and manganese dioxide ores; and the MnO_2 that deposits on the solid electrode has to be removed from time to time during the process. The product is a black powder with a particle size $<74 \mu\text{m}$ (-200 mesh). It contains 2 to 5 percent low-Mn oxides and 3 to 5 percent chemically-bound water.

A number of continuous processes have been devised for the generation of MnO_2 as a precipitate that collects at the bottom of the cell, from which it can be removed without interruption of the electrolysis process.¹

3.2.5 Production of Manganese Chemicals

This subsection describes the production of an important and widely used chemical, potassium permanganate (KMnO_4).

Permanganate can be produced by several different processes. The only one-step process is based on the electrolytic conversion of ferromanganese. The others begin with MnO_2 ore and involve two steps: thermal synthesis of potassium manganate followed by electrolytic oxidation of MnO_4^{2-} to MnO_4^- . The thermal synthesis can be done by roasting or by liquid-phase oxidation.

The roasting processes all involve two steps. First, the formation of K_3MnO_4 is promoted by high temperatures and high-KOH and low- H_2O concentrations. In the second step, the valence of the Mn is converted from 5 to 6 by the use of lower temperatures and control of the moisture in the air.

In the liquid-phase oxidation, maintaining the MnO₂ and KOH ratio at 1:5 or higher causes the mixture to be a liquid.

3.3 OVERVIEW OF END USES OF MANGANESE

Figure 3-1 presents a diagram of the end uses of manganese and manganese compound, and Table 3-5 shows the consumption figures by major usage. Note from Table 3-5 that the consumption of manganese ores decreased significantly in 1982 and has not yet grown back to 1981 levels.

3.3.1 Metallurgical Uses

Table 3-6 shows the consumption of manganese-bearing ferroalloys and manganese metals in the manufacture of various types of steel, cast irons, superalloys, and other products.

The principal use of manganese is in the production of iron and steel. It is essential to the production of virtually all steels, and it is important to the production of cast irons. When added to steel, ferromanganese reacts with the sulfur and retains it as manganous sulfide (MnS). Manganese also acts as a deoxidizer and imparts the alloying effects of strength, toughness, hardness, and hardenability. Silicomanganese is used as the alloy feedstock when both Si and Mn are desired in the steel. Ferroalloys are introduced in the furnace or the ladle, or both.

The amount of alloy feedstock added is directly proportional to the percentage of Mn desired in the steel end product. The most common grades of steel contain about 0.5 to 1.0 percent manganese.

Common grades of ferromanganese contain about 80 percent Mn. The recovery of Mn in the steel is also about 80 percent; the remainder is lost to oxidation (i.e., MnO). Most of the oxides are captured in the slag layer in the ladle, which is discarded, but some escape as emissions during the pouring of the molten steel from the furnace into the ladle.

When ferroalloys are added to molten steel, heavy emissions occur due to rapid oxidation. Emissions from the furnace are generally better controlled than those from the ladle.

Various specialty steels contain higher amounts of Mn; thus, larger amounts of ferroalloy are used. These include spring steels and high-strength, low-alloy steels (in which the Mn content varies from 0.35 to 1.4 percent) and heat-resisting alloys (in which the Mn content varies between 1 and 2 percent).

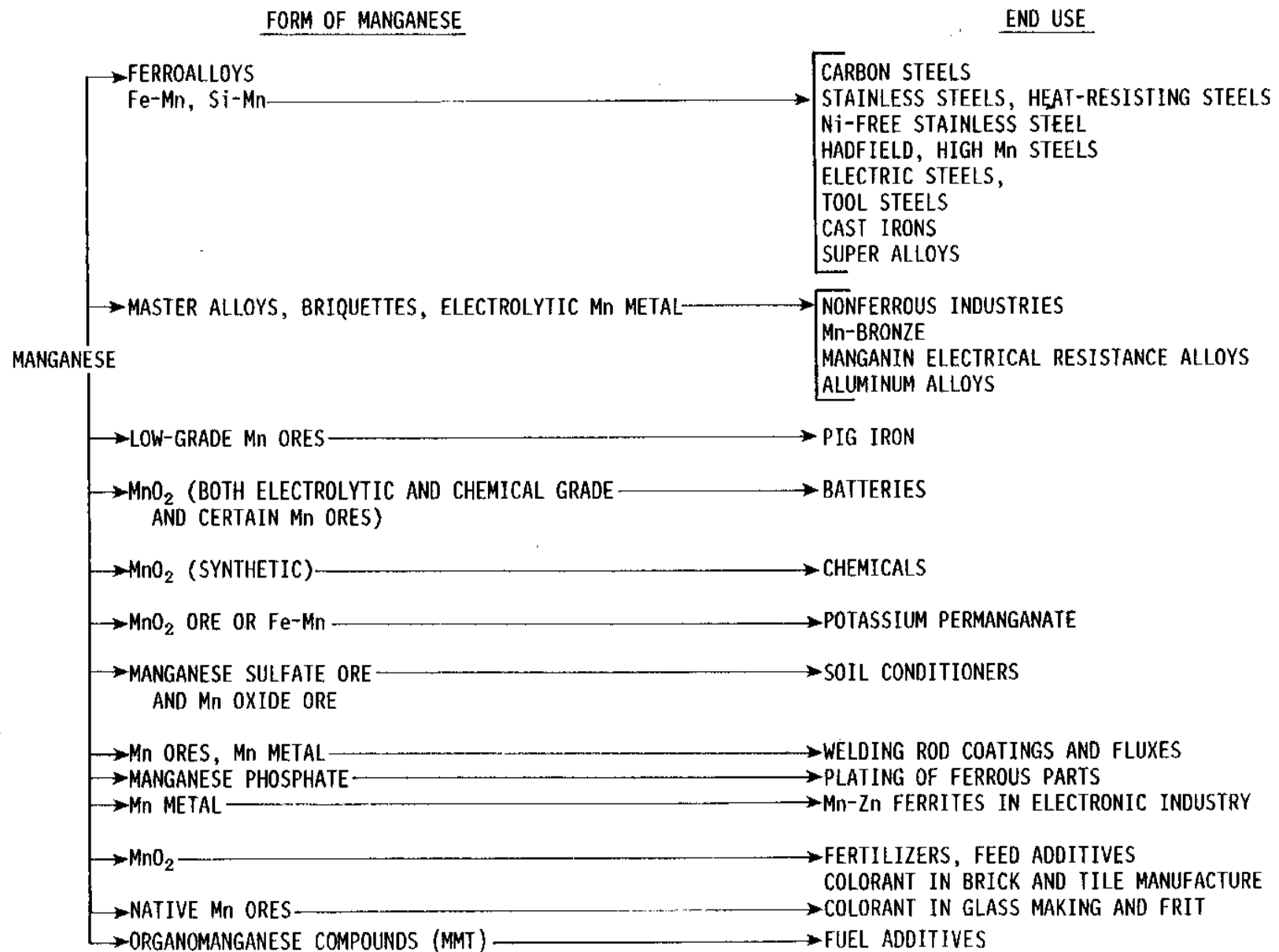

Figure 3-1. End use of manganese and manganese compounds.

TABLE 3-5. CONSUMPTION OF MANGANESE ORES IN THE U.S.^{a,b}
(short tons)

Use	Consumption ^c	
	1981	1982
Manganese alloys and metals	744,832	412,280
Pig iron and steel	147,812	83,906
Dry cells, chemicals, and miscellaneous	183,987	112,555
Total	1,076,631	608,741

^a Containing 35 percent or more manganese.

^b Source: Reference 6.

^c Weights represent total weight of ore, not just manganese content.

TABLE 3-6. U.S CONSUMPTION OF MANGANESE FERROALLOYS
ACCORDING TO END USE IN 1981^a
(short tons, gross weight)

End use	Ferromanganese			
	High carbon	Medium- and low-carbon	Silico-manganese	Manganese metal ^b
Steel:				
Carbon	270,633	58,784	66,601	5,085
Stainless and heat-resisting	7,472	645	3,178	1,803
Full alloy	36,926	8,318	18,343	687
High-strength, low-alloy	29,534	7,032	6,823	704
Electric	16	87	317	80
Tool	179	26	36	52
Unspecified	302	90	551	0
Total steel	345,062	74,982	95,849	8,411
Cast irons	12,543	434	7,736	10
Superalloys	224	NA ^c	NA	126
Alloys (excluding alloy steels and superalloys)	1,289	580	1,785	8,206
Miscellaneous and unspecified	3,549	534	275	388
TOTAL CONSUMPTION	362,667	76,530	105,645	17,141

^a Source: Reference 6.

^b Virtually all electrolytic.

^c NA = Not available.

Other metallurgical uses include the following:

- " Manganese alloys are used as hard facing materials to give abrasion resistance to steel parts.
- " Low-grade manganese ores are directly charged to blast furnaces to recover the contained Mn in the pig iron. (Basic oxygen furnace slag, which contains MnO, is often recycled for Mn recovery by charging it into the blast furnaces or adding it to the sinter feed.)
- " A thin coating of Mn phosphate is used to provide the initial lubrication during the breaking in of parts such as bearings and gears. The coating is applied by immersion in a hot solution of Mn-phosphate.
- " A small quantity of MnO is added to resin-sand mixtures for single investment shell molds used in casting various alloys.
- " Manganese is used as an alloy in nonferrous metals. In manganese bronze, for example, 0.5 to 4 percent Mn is used to impart corrosion resistance.
- " In aluminum alloys, 0.05 to 0.5 percent Mn is added, either as an alloy or in briquettes made of aluminum and manganese powder. Manganese imparts strength, hardness, and stiffness to aluminum.
- " An important use of manganese is in the manufacture of electrical resistance alloys used for electrical instruments. These are essentially Cu-Mn-Ni alloys. Some grades contain 10 to 27 percent Mn.
- " Another Mn alloy, which contains 12 percent Mn, is used in the bimetallic element of thermostats.

3.3.2 Nonmetallurgical Uses of Manganese Oxides

Table 3-7 lists the primary nonmetallurgical uses of manganese oxides. Some of these uses are briefly addressed in the following items:

- " High-purity MnO is used in the production of high-quality ferrites. The Mn-zinc ferrites are used in items such as magnetic recording heads, digital and video recordings, and bubble memories.
- " Low-grade MnO is used as a colorant in the manufacture of brick and tile. Low-grade native ores are used as colorants in glass making and frits.
- " Manganese oxide is used in uranium hydrometallurgy for oxidizing the uranium dioxide (UO₂) to uranium dioxide sulfate (UO₂SO₄).
- " Native ores containing MnO₂ are used in the manufacture of welding rod coatings and fluxes.

TABLE 3-7. PRIMARY NONMETALLURGICAL USES OF MANGANESE OXIDES^a

Compound	Applications
Manganese (II) oxide Technical	Fertilizer Feed additive Intermediate in the manufacture of electrolytic Mn metal, Mn (II) salts, EMD
High-purity	High-quality ferrites; ceramics intermediate for higher-purity Mn (II) salts such as Mn(H ₂ PO ₄) ₂ Mn acetate
Dimanganese trioxide Trimanganese tetroxide	High-purity grades used in production of ferrites, thermistors, and in other electronic applications
Manganese dioxides	Colorant in brick and tile manufacturing
Native ores	Colorant in glass making frits Raw materials for most other Mn chemicals Hydrometallurgy of uranium Hydrometallurgy of zinc Welding rods and fluxes Dry-cell batteries Oxidant in chemical processes Absorbent for H ₂ S and SO ₂ Ferrites (lower grade)
Chemical manganese dioxide	Dry-cell batteries, oxidant in organic synthesis, high-purity MnO ₂ for ferrites and thermistors, curing agent for polysulfide rubbers, constituent in oxidation catalysts
Electrolytic manganese dioxide	Dry-cell batteries, ferrites

^a Source: Reference 1.

- " Synthetic MnO₂ is used extensively in the manufacture of dry-cell batteries.
- " Manganese ore is used as an oxidant in the production of hydroquinone in a process that generates byproduct manganese sulfate.

3.3.3 End Uses of Manganese Compounds

Table 3-8 lists the primary uses of various manganese compounds, and Table 3-9 presents a separate listing of the principal uses of potassium permanganate, one of the better-known compounds. This latter compound is used extensively in the manufacture of chemicals, in inorganic synthesis, as an oxidizer in water purification to remove odors, in metal-surface treating, and as a bleaching agent.

REFERENCES FOR SECTION 3

1. Kirk-Othmer. Encyclopedia of Chemical Technology. 3d Ed., Vol. 14. 1981.
2. National Research Council. Medical and Biological Effects of Environmental Pollutants--Manganese. National Academy of Sciences, Washington, D.C. 1973.
3. Weast and Astle. Handbook of Chemistry and Physics. 61st Ed. CRC Press. 1980-81.
4. Bureau of Mines. Mineral Commodity Summary - 1985; Manganese. U.S. Department of Interior. 1985.
5. Letter from W. R. Pioli of Elkem Metals Co. to T. Lahre of EPA, January 31, 1985.
6. Jones, T. S. Minerals Yearbook: Manganese. U.S. Department of Interior, Bureau of Mines. 1982.

TABLE 3-8. PRIMARY USES OF MANGANESE COMPOUNDS^a

Manganese	Application
Mn Salts of inorganic acids Carbonate	Intermediate in the synthesis of other Mn salts, such as phosphate, gluconate, acetate, nitrate; for manufacture of ferrites, welding rods, also as hydrogenation catalyst
Mn Chloride	Magnesium metallurgy; synthesis of MMT as brick colorant; textile dyeing, dry cell batteries, chlorination catalyst
Mn Trifluoride	Fluorination agent
Mn Hypophosphite	Manufacture of delustered polycondensate fibers, i.e., nylon
Mn Nitrate	Intermediate in manufacturing of high purity Mn oxides; in production of tantalum capacitors
Mn Phosphate (monobasic)	Rust-proofing; wear-reduction in moving metal parts (bearings, etc.)
Mn Pyrophosphate	Textile dyeing
Mn Sulfate	Intermediate in manufacture of many Mn products, i.e, electrolytic Mn metal, EMD, Maneb, Mn soaps, etc.; important Mn fertilizer, feed additive, for organic pigments, catalyst in H ₂ S oxidation
Mn	Salts of organic acid
Acetate	Oxidation catalyst in manufacture of dibasic acids (i.e., terephthalic, adipic acids) for synthetic fibers; also polymerization catalyst
Acetylacetonate	Catalyst
Ethylenebis(dithio carbanate)(Maneb)	Fungicide
Gluconate	Feed and food additive; dietary supplement
Glycerophosphate	Food additive, dietary supplement
Lactate	Medicine
Soaps ^b	Driers in printing inks, paints, and varnishes
Mn chelates (complexes with EDTA, lignosulfonates, dibasic sugar acids, gluconic acid)	Liquid fertilizers, as feed and food additives
Metalorganic methylcyclopentadienyl manganese tricarbonyl (MMT, CI-2)	Antiknock additive for motor fuels, combustion improver for heavy fuel oils

^a Source: Reference 1.

^b Borate, linoleate, naphthenate, oxalate, phthalate, resinate, stearate, tallate, neodecanoate, octoate.

TABLE 3-9. PRINCIPAL USES OF POTASSIUM PERMANGANATE^a

General Category ^b	Specific Application
Chemical manufacture and processing Organic synthesis	Important industrial oxidant in the manufacture of chemical and pharmaceutical intermediates; also used as oxidation catalyst, e.g., in fatty acid production from paraffins
Inorganic manufacture	Mn catalysts, Purafil
Purifying agent	Organic compounds, mostly solvents
Environmental	
Water	Potable: removal of Fe-Mn, taste and odor; control of trihalomethanes Industrial and waste; removal of phenol and other organic contaminants; radioactive decontamination; cleanup of acid mine drainage
Air	Industrial effluents: removal of odorous constituents by wet scrubbing (rendering and roofing plants; foundries; food processing plants; sewage plants) Indoor spaces; odor control with Purafil (solid formulation containing KMnO_4)
Metal-surface treatment	Scale and smut removal from carbon steel and stainless steels
Hydrometallurgical uses	Purification of zinc sulfate solution in electrowinning of zinc; Fe-Mn removal from ZnCl_2 solns
Miscellaneous	Bleaching of beeswax, jute fibers, clays; in fishery management for detoxification of fish poisons; alleviation of temporary oxygen depletion, control of fish parasites, etc; as laboratory chemical in analytical and preparative organic chemistry

^a Source: Reference 1.^b Arranged in order of importance.

SECTION 4
MANGANESE EMISSIONS FROM PRODUCTION
AND USE OF MANGANESE

In this discussion, manganese emission sources are divided into two categories--direct and indirect sources. The direct category primarily includes sources that either produce manganese or consume manganese or a manganese compound to manufacture a usable product. Direct sources of manganese emissions include the following:

- " Manganese ore beneficiation, transport, and storage
- " Production of manganese-bearing ferroalloys
- " Production of manganese metal and manganese oxides
- " Production of manganese chemicals
- " Iron and steel production
- " Iron and steel foundries
- " Manufacture of batteries

Indirect sources of manganese emissions are generally those that do not produce manganese or manganese-containing products and only inadvertently handle manganese because it is present as an impurity or additive in a feed- stock or fuel. For example, manganese is released from the combustion of coal or oil because it is a trace constituent in these fuels. Indirect sources include:

- " Coal and oil combustion
- " Production of cement
- " Incineration of municipal refuse and sewage sludge
- " Manganese fuel additives

4.1 MANGANESE ORE BENEFICIATION, TRANSPORT, AND STORAGE

In 1982, no manganese ore containing 35 percent or more manganese was either produced or shipped from domestic mines in the United States.¹ Although lower-grade manganiferous ores (5 to 10 percent manganese) were produced and/or shipped in Minnesota and South Carolina, the quantities were much lower than in 1981.¹ No ferruginous manganese ores or concentrates (10 to 35 percent Mn) were produced, but some were shipped (on a much curtailed basis) from the Cuyuna Range in Minnesota.¹ Some manganiferous schist (5 to 15 percent Mn) also was mined in Cherokee County, South Carolina, for use by brick manufacturers to color the brick. Total shipments of all domestic manganese ores amounted to only 31,509 tons in 1982; down from 175,000 tons in 1981; manganese content of these ores totaled only 3984 tons.¹

Mined from open pits, manganese ores are beneficiated by conventional means involving crushing, washing, and concentration with jigs and Deister tables.

Because domestic production and reserves are limited, Mn ores and Mn-bearing ferroalloys are considered strategic materials and government stockpiles are maintained. Imported ores and ferroalloys are stored at designated stock piles, some in open areas and others in closed areas. These imported ores have already been beneficiated, and all contain more than 35 percent Mn. The ores are further crushed and blended (as required) by processing plants near the port of entry before they are dispatched to the point of final consumption.

4.1.1 Emissions and Emission Factors

Fugitive emissions of manganese occur during the crushing, transfer, and stockpiling of manganese-bearing ores, and as a result of wind erosion of the stockpiles. Estimates of other fugitive emissions can be generated by the use of predictive equations developed for open dust sources at iron and steel mills.² Data on the silt content of the ore piles, moisture content of the ore, number of dry days in the year, duration of material storage, and handling methods are required for these equations. Process-specific emission factors for crushing and transfer of manganese ores are presented in the appropriate sections of this document (Section 4.2.3, for example).

REFERENCES FOR SECTION 4.1

1. Jones, T. S. Minerals Yearbook, Vol. 1, Metals and Minerals. U.S. Department of the Interior. 1983.
2. Cowherd, C. Iron and Steel Plant Open Source Fugitive Emission Evaluation. Midwest Research Institute, Kansas City, Missouri. EPA-600/2-79-103, 1979.

4.2 PRODUCTION OF MANGANESE-BEARING ALLOYS

In 1982, around 20 percent of the ferroalloys produced in the United States contained manganese. The use of ferroalloys has progressively decreased since 1979 in proportion to the decrease in steel production.¹ Table 4-1 indicates the specifications and typical composition of manganese ferroalloys. High-carbon ferromanganese constitutes more than 80 percent of the total ferromanganese used.² Currently, all manganese ferroalloys are produced by electric arc furnaces, with one exception. The Chemetals Corporation plant at Kingwood, West Virginia, produces manganese metal with low carbon content by fused salt electrolysis. The Bureau of Mines classifies this product (also known as Massive Manganese) as low-carbon ferromanganese.³ The production of manganese metal is described in Subsection 4.2.3.

Figure 4-13 is a generalized flow sheet of the production of manganese bearing ferroalloys. Manganese ores and other raw materials are brought in by rail or trucks and stored in stockpiles. The ore is crushed to the required size and screened. The fines and undersize are collected and sintered in a sintering machine. The sintered fines and sized ore are then fed to the stock bins, from which measured quantities of the feed mix are charged into an electric furnace.

4.2.1 Electric Arc Furnace Process

Three types of submerged-arc electric furnaces are used to make the ferroalloys: open, semisealed, and sealed furnaces.⁵ These furnaces are charged either continuously or intermittently with the manganese ores, a reducing agent (e.g., coke or coal), and fluxes (e.g., lime). The blend of ores is based on cost, availability, and composition to give a proper balance of slag-forming constituents.

TABLE 4-1. SPECIFICATIONS AND TYPICAL
COMPOSITIONS OF MANGANESE FERROALLOYS^{a,b}
(weight percent)

Alloy	Mn	C, max	Si, max	P, max	S, max	As, max	Fe	Pb, max
Ferromanganese								
High-carbon								
Grade A	78-82	7.5	1.2	0.35	0.05	0.30	7.8-11.8	0.050
Grade B	76-78	7.5	1.2	0.35	0.05	0.30	11.8-13.8	0.050
Grade C	74-76	7.5	2.2	0.35	0.05	0.30	13.8-15.8	0.050
Typical commodity grade	78-80	6.7	0.7	0.30	0.04	0.25	12-14	0.050
Medium-carbon								
Regular grade	80-85	1.5	1.5	0.30	0.02	0.10	7-12	0.020
MS grade ^c	80-85	1.5	0.35	0.30	0.02	0.15	11-16	0.050
Low-carbon	85-90	^a	2.0	0.20	0.02	0.10	7-12	0.020
Silicomanganese	65-68	2.00	16.0-18.5	0.20	0.04	0.10	10.5-16	0.030
Ferromanganese silicon	63-66	0.08	28-32	0.08	0.04	0.15	1-8	0.050

^a Reference 4.

^b C = carbon; P = phosphorus; S = sulfur; As = arsenic; Pb = lead.

^c Machine-silicon grade.

^d May have any of the following percentages: 0.50, 0.30, 0.15, 0.10, and 0.070 percent C.

^e Also known as low-carbon silicomanganese.

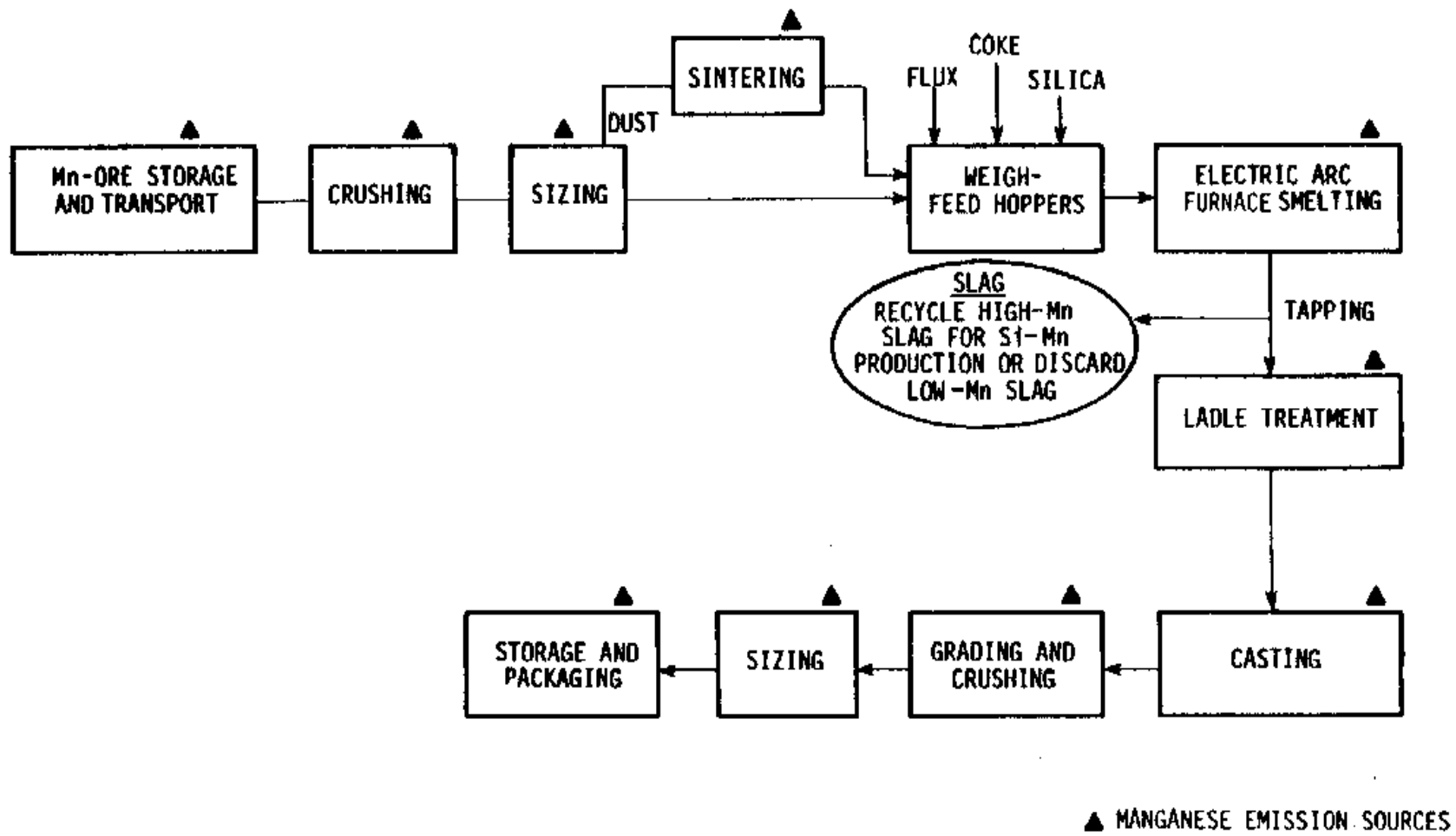

Figure 4-1. Flow chart of manganese-bearing ferroalloys production by electric arc furnace process.

The electric submerged-arc furnace consists of a refractory-lined hearth and water-cooled steel shell. A taphole is provided for draining metal and slag. Carbon electrodes are vertically suspended above the hearth in a triangular formation. Normally, three electrodes, which may be prebaked or the self-baking, Soderberg type, extend 1 to 1.5 m (3 to 5 ft) into the charge materials. Three-phase current passes through the charge materials from electrode to electrode, and the electrical energy smelts the charge. Coke and other reducing materials that are added to the furnace react with the oxygen in the metal oxides to form carbon monoxide and base metal. Furnace emissions consist of carbon monoxide, particulate matter, and metal vapors. Molten ferroalloy and slag are intermittently tapped into ladles. Slag from the metal ladle overflows into a slag pot. The slag is water-cooled and processed. If the slag has a high manganese content and is going to be used in the manufacture of silico-manganese, it is crushed and recycled. If the manganese content is low and the slag is going to be discarded, it is processed and sold for ballast or disposed of in landfills. In either case, slag processing is a source of manganese emissions.

The furnaces and tapping stations are hooded, and the gases are ducted to a particulate control device. The configuration of the hood and/or furnace roof determines whether the furnace is categorized as open, semi sealed, or closed.

The configuration of the open furnace is such that a canopy hood (through which the electrodes extend) is located 2 to 2.7 m (6 to 8 ft) above the furnace rim (Figure 4-2). This opening between the furnace and hood permits large amounts of air to enter the hood and exhaust system. As the air combines with the hot exhaust gases, the carbon monoxide and most of the organic compounds are burned and the furnace emissions are diluted and cooled by the ambient air. This type of furnace is by far the most popular in the United States because of its product flexibility and because it can be stoked during operation. If sufficient draft is not provided, however, the large opening around the hood allows fumes to escape. Control equipment must be designed to handle the large volume of gas inherent in an open furnace design.

The semisealed furnace has a water-cooled hood that fits tightly around the top of the furnace and is vented to an air pollution control system (Figure 4-3). The electrodes extend down through the hood, and raw materials are charged through annular gaps around the electrodes.

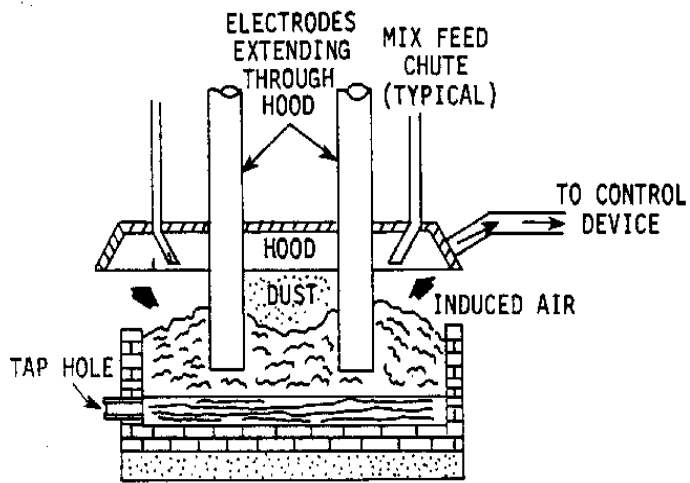

Figure 4-2. Open furnace.

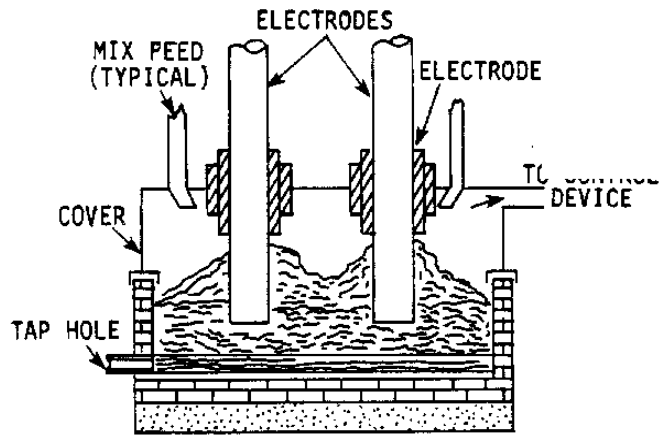

Figure 4-4. Sealed furnace.

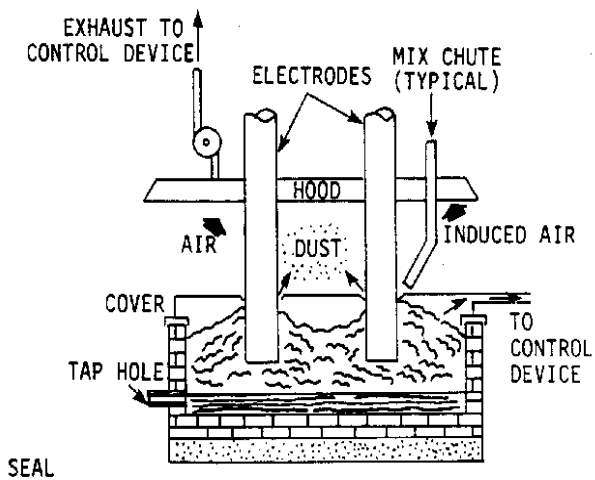

Figure 4-3. Semisealed furnace.

CONTROL

Because the seal provided by the raw material mixture around each electrode is not air-tight, fumes may escape unless sufficient draft is provided by the air pollution control system. Much less outside air is drawn into this system than into the open furnace, and the pollutant concentrations are much higher. The resulting gases are high in carbon monoxide. These furnaces cannot be readily stoked from the outside.

The sealed furnace has a tight-fitting, water-cooled hood on top, which is vented to an air pollution control system (Figure 4-4). Raw materials are fed through separate sealed chutes, and the electrodes penetrate the hood through seals. Thus, the furnace is completely sealed and operates under a slight positive pressure regulated by the fume exhaust system. No outside air enters the furnace system, and high concentrations of CO (80 to 90 percent) and particulates are emitted. No sealed furnaces are in use in the United States;⁸ however, they are used for Fe-Mn production in Japan and Canada.

Regardless of the type of furnace used, the molten ferromanganese is cast into molds or in a casting machine. The solidified product is removed from the molds, crushed, sized, and stored for shipment. The casting, crushing, and sizing steps produce particulate emissions containing manganese.

High-carbon ferromanganese and silicomanganese are produced in both open and semi sealed furnaces. The same furnace can be used for both, provided the gas cleaning system has the capacity and the furnace can be operated at the higher power rate required for silicomanganese.

4.2.2 Emissions and Emission Factors

The possible sources of manganese emissions from the production of manganese ferroalloys by the electric arc furnace process are shown in Figure 4-1. Ore handling and wind erosion of the stockpile result in emissions of Mn-bearing particulates. Emissions from storage piles can be reduced by erecting wind barriers, covering the piles with plastic, or spraying them with water. The extent of such practices is unknown. Pretreatment of the Mn ore, including crushing and screening, also produces emissions.

The smelting of Mn ore and other raw materials in the electric arc furnace is the major source of Mn emissions. All three types of electric arc furnaces (open, semi sealed, and sealed) emit Mn-bearing particulates. Open furnaces generate the highest level of emissions

because the large opening between the furnace rim and hood allows more circulation of air and gases through the charge material, which entrains Mn and other particulates.

Fabric filters are used to control emissions from submerged-arc furnaces producing ferromanganese. Testing of these control systems has indicated a total particulate removal efficiency of over 99 percent.⁶

High-pressure-drop venturi scrubbers that have been applied to submerged arc furnaces producing ferromanganese alloys reportedly have particulate collection efficiencies ranging from 94 to 98 percent.⁶ Wet scrubbers, including both multistage centrifugal scrubbers and venturi scrubbers, have been used on semisealed ferroalloy furnaces. A particulate removal efficiency as high as 99 percent has been reported for centrifugal scrubbers.

Because no air enters sealed furnaces, gas volumes to the control device are only 2 to 5 percent of those from open furnaces. This results in a much smaller mass of particulates. Venturi scrubbers are commonly used on these furnaces.

The tapping of molten ferroalloys from the furnace into a ladle is a source of emissions in all three types of furnaces. Ten to 15 percent of the furnace operating time involves tapping operations, during which fumes and some particulates are emitted. Hood systems are sometimes installed over the tapping hole and ladle to capture and direct the emissions to a fabric filter or scrubber.⁶

Additional Mn emissions occur during casting and finishing operations. Particulates and fumes escape as the molten product is poured into molds. Casting operations may be hooded, but emissions from casting are uncontrolled at many ferroalloy plants. Other sources of Mn emissions include the final crushing, sizing, and packaging of the ferroalloy products. Most plants control these operations with fabric filters or scrubbers.²

Manganese emission factors for ferroalloy production can be calculated from data available in the literature. A 1974 U.S. EPA study estimated particulate emissions from raw materials handling and processing at 16 electric arc furnace ferroalloy plants.² The specific types of ferroalloys these plants produced was not specified. Because the raw material handling procedures for Mn-bearing ferroalloys are similar to those for the production of other ferroalloys, however, it was

assumed that particulate emission factors for general ferroalloy production also apply to the production of Mn ferroalloys. To derive Mn emission factors from total particulate emission factors required the further assumption that metallurgical-grade Mn ore contains an average of 45 percent Mn by weight. Table 4-2 presents the derived Mn emission factors for raw material processing.

Reference 22 also lists particulate emissions from handling and finishing of ferroalloy products, including casting, crushing, and grinding. The Mn content of particulate emissions varies with the Mn content of the ferroalloy being produced. The composition of Mn ferroalloys can range from 75 to 90 percent in ferromanganese to 63 to 68 percent in silicomanganese. Table 4-3 presents derived Mn emission factors for these operations. The Mn emission factors were obtained by multiplying average total particulate emissions from finishing and handling by 80 and 65 percent for ferromanganese and ferrosilicon, respectively.

Table 4-4 presents derived emission factors for ferromanganese-producing furnaces. Uncontrolled emission factors are based on AP-42 data for ferroalloy production. The total particulate emission factors were multiplied by the measured average percent Mn in particulate emissions. Table 4-5 presents a chemical analysis of particulate emissions from ferromanganese and silicomanganese furnaces. Most of the controlled Mn emission factors were based on tests of total particulate emissions. Again, these were multiplied by the measured typical percent Mn in particulate emissions from Mn-bearing ferroalloy furnaces.⁵

4.2.3 Source Locations

In 1982, five plants manufactured ferromanganese and silico-manganese in electric arc furnaces.⁵ In 1980, nine plants were producing manganese-bearing ferroalloys, but three of these suspended production because of the low market demand. Table 4-6 lists the plants that were actively engaged in production of manganese-bearing ferroalloys in 1980. An upturn in the domestic steel industry could alter the demand pattern and bring some of the domestic manufacturers back on line. Imported products are economically competitive and have obtained a significant share of the market.

TABLE 4-2. MANGANESE EMISSION FACTORS FOR PROCESSING OF RAW MATERIALS AT MANGANESE-BEARING FERROALLOY PRODUCTION FACILITIES^a

Source	Mn emission factors, kg/Mg (lb/ton) of Mn ore processed	
	Receipt and storage of Mn ore	0.45
Crushing and sizing	0.45	(0.90)
Weighing and feeding	0.40	(0.80)

^a Based on an average Mn content of 45 percent in the manganese ore. The emission factors are expressed in terms of elemental manganese. Manganese is probably present as an oxide or silicate along with other metal oxides and silicates. These factors are based on information obtained from questionnaires to the industry and predictive equations developed for the iron and steel industry.²

TABLE 4-3. MANGANESE EMISSION FACTORS FOR FINISHING OPERATIONS^a

Source	Mn emission factors, kg/Mg (lb/ton) of Mn product			
	Ferromanganese		Silico-manganese	
Ladle treatment	3.75	(7.5)	3.0	(6.0)
Casting	0.24	(0.48)	0.12	(0.24)
Crushing/grinding/sizing	0.08	(0.16)	0.065	(0.13)

^a Based on an average Mn content of 80 and 65 percent in FeMn and SiMn, respectively. The emission factors are expressed in terms of elemental manganese. These factors are based on information obtained from questionnaires to the industry and predictive equations developed for the iron and steel industry.² Some sources may employ more stringent controls than are reflected in these factors.

TABLE 4-4. MANGANESE EMISSION FACTORS FOR SUBMERGED-ARC ELECTRIC FURNACES PRODUCING FERROMANGANESE AND SILICOMANGANESE^a

Product	Furnace type	Manganese emission factors ^b	
		Kg/Mg (lb/ton) of product	kg/MWh ^c (lb/MWh)
Uncontrolled sources			
Ferromanganese	Open	6.6 (13.2)	2.8 (6.16)
Ferromanganese	Semisealed	2.6 (5.2)	1.06 (2.33)
Ferromanganese	Sealed	9.6 (19.2)	4.3 (9.46)
Ferromanganese ^d	NA ^e	5.7 (11.4)	NA
Silicomanganese ^d	NA	23.2 (46.4)	NA
Controlled sources			
Ferromanganese	Open (controlled by scrubbers)	0.2 (0.4)	0.086 (0.189)
Ferromanganese	Semi sealed (controlled by scrubbers)	0.04 (0.08)	0.017 (0.037)
Ferromanganese	Sealed (controlled by scrubbers)	NA	0.0038 (0.008)
Silicomanganese	Open (controlled by scrubbers)	NA	0.05 (0.11)
Silicomanganese	Semisealed controlled by scrubbers)	0.06 (0.032)	0.004 (0.009)
Silicomanganese	Sealed (controlled by scrubbers)	NA	0.001 (0.002)

^a References 2, 5, and 6. Some sources may employ more stringent controls than are reflected in these factors.

^b Chemical form of particulate is specified in Table 4-5.

^c "MWh" refers to megawatt-hours of electrical energy consumed by furnace during operation.

^d Uncontrolled emissions based on AP-42 factors for ferroalloys.

^e NA = not available.

TABLE 4-5. CHARACTERIZATION OF PARTICULATE EMISSIONS FROM FERROALLOY FURNACES^a

Parameter	SiMn	FeMn
Furnace hood type	Covered	Open
Particle size, μm		
Maximum	0.75	0.75
Range of most particles	0.2-0.4	0.05-0.4
Chemical analysis, wt %		
SiO ₂	15.63	25.48
FeO	6.75	5.96
MgO	1.12	1.03
CaO	NA	2.24
MnO	31.35	33.60
Al ₂ O ₃	5.55	8.38
Loss on ignition	23.25	NA

^a Reference 2. Some sources may employ more stringent controls than are reflected in these factors.

NA - Not available.

TABLE 4-6. DOMESTIC PRODUCERS OF MANGANESE FERROALLOYS, 1980^a

Producer	Plant location	Products	Type of process
Autlan Manganese Chemetals Corp.	Mobile, Ala. Kingwood, W. Va.	SiMn FeMn	Electric furnace Fused-salt electro- lytic
Interlake, Inc., Roane Ltd.	Beverly, Ohio Rockwood, Tenn.	SiMn FeMn, SiMn	Electric furnace Electric furnace
SKW Alloys, Inc. Elkens Metal Co.	Calvert City, Ky. Marietta, Ohio	FeMn, SiMn FeMn, SiMn	Electric furnace Electric furnace

^a References 7 and 8.

Note: This listing is subject to change as market conditions change, facility ownership changes, plants are closed, etc. The reader should verify the existence of particular facilities by consulting current listings and/or the plants themselves. The level of manganese emissions from any given facility is a function of variables such as capacity, throughput, and control measures, and should be determined through direct contacts with plant personnel.

REFERENCES FOR SECTION 4.2

1. American Iron and Steel Institute. Annual Statistical Report. 1982.
2. Dealy, J. O., and A. M. Killin. Engineering and Cost Study of the Ferro-alloy Industry. EPA-450/2-74-008, May 1974.
3. Jones, T. S. Mineral Commodity Profiles. Manganese - 1983. Bureau of Mines, U.S. Department of the Interior. 1983.
4. Kirk-Othmer. Encyclopedia of Chemical Technology. Vol. 14. John Wiley & Sons, Inc., New York. 1981.
5. Szabo, M. F., and R. W. Gerstle. Operation and Maintenance of Particulate Control Devices on Selected Steel and Ferroalloy Processes. EPA-600/2-78-037, March 1978.
6. U.S. Environmental Protection Agency. A Review of Standard of Performance for New Stationary Sources--Ferroalloy Production Facilities. EPA-450/3-80-041, December 1980.
7. Bureau of Mines. Minerals Yearbook. Volume 1, Metals and Minerals. U.S. Department of the Interior. Washington, D.C. 1980.
8. Letter from W. R. Pioli of Elkem Metals Co. to T. Lahre of EPA, January 31, 1985.

4.3 PRODUCTION OF MANGANESE METAL AND SYNTHETIC MANGANESE OXIDE

4.3.1 Manganese Metal

Manganese metal is produced by one of two electrolytic processes: electrolysis of aqueous solution, or 2) electrolysis of fused salt.

When electrolysis of aqueous solution is used, the manganese ore is crushed, ground, and roasted to reduce the higher oxides to Mn (II) oxide, which is acid soluble. Elkem Metals, Marietta, Ohio, uses a process in which Mn (II) oxide is supplied from the slag produced in the high-carbon ferromanganese smelting operation. The reduced ore or slag is leached with H₂SO₄ at pH 3 to yield Mn (II) sulfate. This solution is neutralized with ammonia to a pH of 6 to 7 to precipitate Fe and Al, which are later removed by filtration. Tramp metals are removed as sulfides by the introduction of H₂S gas. Ferrous sulfide or aluminum sulfide plus air are then introduced to remove colloidal sulfur, colloidal metallic sulfides, and organic matter. The purified liquid is electrolyzed in a diaphragm cell. The Mn metal deposits on the cathode are thin and brittle and about 99.5 percent pure.¹

In the fused salt electrolysis process (developed by Chemetals Corporation), the feed Mn ore, which is reduced to Mn (II), is charged to an electrolytic cell that contains molten calcium fluoride and lime. Fluorspar and lime are added to maintain the desired fused salt composition. As the volume of fused salt increases, excess fused electrolyte is periodically removed. The cell is operated at about 1300°C to maintain the Mn in a molten stage. Manganese metal is tapped from the cell periodically and cast into cast-iron pots. The metal produced is 92 to 98 percent pure, the main impurity being Fe.² Manganese ore that has been chemically pretreated to remove iron is used as cell feed to produce 98 percent pure Mn grade metal.

4.3.2 Synthetic Manganese Oxides

The two kinds of synthetic manganese dioxides are Chemical Manganese Dioxide (CMD) and Electrolytic Manganese Dioxide (EMD). The CMD is further subdivided into Type 1 and Type 2. Type 1 CMD is produced by chemical reduction of permanganate, and Type 2 CMD is produced by thermal decomposition of Mn salts, such as $MnCO_3$ or $Mn(NO_3)_2$, under oxidizing conditions. Figure 4-5 is a generalized flow diagram for CMD, Type 1 and Type 2.

Type 1 CMD--

When potassium permanganate ($KMnO_4$) is used in organic oxidations, such as in the conversion of O-toluenesulfonamide to saccharin, byproduct MnO_2 is generated. To obtain battery grade synthetic oxide requires the removal of excessive quantities of adherent and bound alkali by treating the material with H_2SO_4 or HCl and then with $MnSO_4$. Subsequent treatment with $KMnO_4$ solution converts the ion-exchanged divalent Mn into MnO_2 . The product is then washed and dried at low temperature. This Type 1 hydrate (known as Manganit) is also sold under the trade name of Permanox in Europe.¹

Type 2 CMD--

The manufacture of Type 2 CMD by thermal decomposition of $Mn(NO_3)_2$ gives high-purity MnO_2 (99 percent). The pH of an aqueous solution of impure $Mn(NO_3)_2$ is adjusted to between 4 and 5.5, which causes contaminants such as aluminum (Al) to precipitate as hydroxides. The mixture then is heated to about 90° to 100°C and filtered. The filtrate is first concentrated to 55 percent by weight and then mixed with

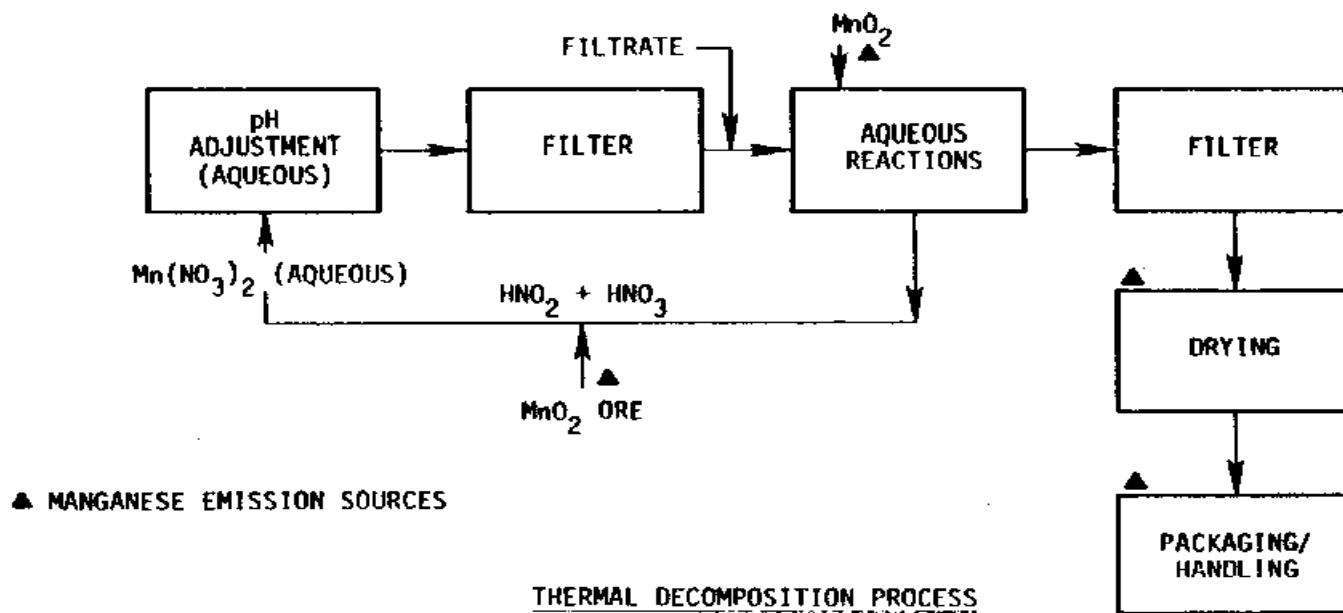
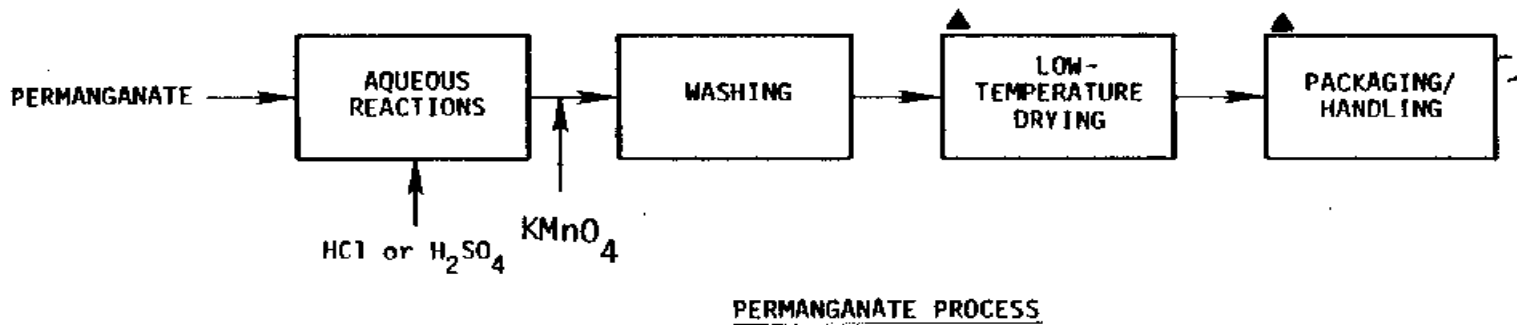

Figure 4-5. Generalized flow diagrams for chemical MnO_2 production.³

previously made MnO_2 . This mixture is heated to between 139° and $146^\circ C$ while being vigorously agitated. The decomposition of $Mn(NO_3)_2$ is controlled. The NO_2 generated is allowed to react with water and thereby forms nitrous and nitric acids (HNO_2 and HNO_3). This acid mixture is then used to convert new MnO_2 ore into $Mn(NO_3)_2$. The MnO_2 produced by thermal decomposition is filtered and dried before it is packaged.

Electrolytic Manganese Dioxide (EMD)--

The starting material for EMD is either rhodochrosite ($MnCO_3$) ores or MnO_2 ores. The former ores are used primarily in Japan. After the $MnCO_3$ ore has been dried and ground, it is treated with 10 percent excess H_2SO_4 . A small amount of finely ground MnO_2 is added to the reaction mixture to oxidize the divalent iron present. The pH of the slurry is adjusted to between 4 and 6 with $Ca(OH)_2$ or $CaCO_3$. The solids are removed by filtration and the filtrate containing $MnSO_4$ is sent for further electrolysis.

When MnO_2 ores (minimum 75 percent MnO_2 in ore) are used, the MnO_2 ore is first roasted (with a reducing agent) in rotary kilns to convert the MnO_2 to MnO . After the reduction, the solid mixture is allowed to cool to below $100^\circ C$ in an inert or reducing atmosphere. The subsequent leaching step with H_2SO_4 is similar to the rhodochrosite ore process just described, except that it involves an additional step in which heavy metals are precipitated by the addition of H_2S or CaS . The Kerr-McGee Chemical Corporation uses a process in which MnO is wet-ground with leach solution in a ball mill before it is contacted with acid effluent from electrolytic cells.¹ Figure 4-6 is a generalized flow diagram of the EMD production process.

The electrolytic cells are usually rectangular open troughs lined with corrosion-resistant material. The electrodes are flat plates or cylindrical rods or tubes. The anodes are generally made of hard lead and can be easily removed for stripping of the END deposits. The cathodes are made from graphite, soft or hard lead, or stainless steel.

The EMD is stripped from the anodes manually or by an automated system. The lumpy fragments of raw MnO_2 are washed with water, dried, and ground. After a neutralization step, they are further dried and packed.

4.3.3 Emissions and Emission Factors

The major operations in the electrolytic process of Mn metal production (aqueous solution electrolysis) and MnO_2 manufacture by both

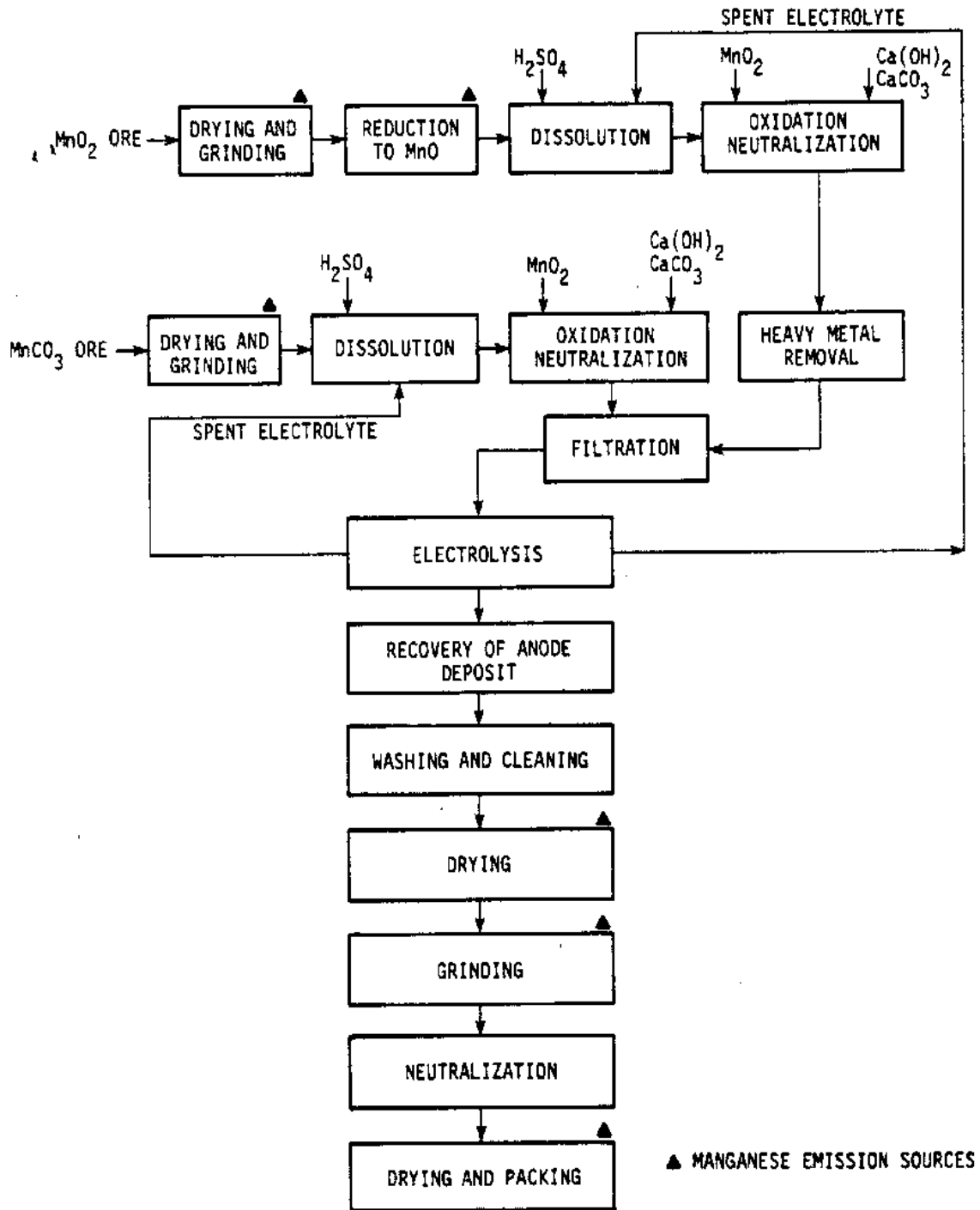

Figure 4-6. Electrolytic MnO₂ production from MnO₂ ores and rhodochrosite ores.¹

chemical and electrolytic methods do not generate particulate emissions containing Mn; however, Mn-bearing particulate emissions are likely to occur from the drying, grinding, and roasting operations, and fugitive emissions can result from product handling and packaging. The possible sources of Mn emissions are shown in the flow diagrams (Figure 4-5 and Figure 4-6) for both chemical and electrolytic MnO₂.

Table 4-7 presents Mn emission factors for drying, grinding, roasting, handling, and packaging operations. The emission factors are arrived at by multiplying the particulate emission factor by the average percentage of Mn in the materials handled.

TABLE 4-7. DERIVED MANGANESE EMISSIONS FOR SYNTHETIC MANGANESE PRODUCTION^a

Source	Control equipment	Particulate emissions factors, kg/Mg of material Processed (lb/ton)	Manganese emission factors, kg/Mg of material Processed (lb/ton)
Drying and grinding	Uncontrolled	9.9 (19.8) ^b	4.45 (8.9) ^c
	Fabric filters	0.0099 (0.0196)	0.0045 (0.009)
Roasting ^d	Uncontrolled	122 (245) ^e	55 (110) ^c
	Fabric filter	0.244 (0.49)	0.11 (0.22)
Packaging/handling	Uncontrolled	4.4 (8.8) ^b	2.7 (5.4)
	Fabric filters	0.0044 (0.0088)	0.0027 (0.0054)

^a During ore processing, particulate emissions will be the same composition as the ores. Manganese is present in these emissions as an oxide or silicate. If manganese metal is the product, particulate emissions in the form of manganese metal may be emitted during packaging and handling operations.

^b Reference 3.

^c The Mn content will vary based on the starting materials (Average - 45%). MnO₂ ores (minimum 75% MnO₂) will contain 47.4% Mn. Rhodochrosite will contain 47.8% Mn.

^d Many different roasting processes are used. The emission factor given is for kiln-type roasting. (Assumed to be same as for cement manufacture.)

^e Reference 4.

4.3.4 Source Locations

Table 4-8 lists the locations of manufacturers of manganese metal and synthetic manganese oxides.

TABLE 4-8. DOMESTIC PRODUCERS OF MANGANESE METAL AND SYNTHETIC MANGANESE DIOXIDE^a

Producer	Plant locations	Products	Type of process
<u>Electrolytic manganese metal</u>			
Elkem Metals Company	Marietta, Ohio	Mn	Electrolytic
Foote Mineral Company	New Johnsonville, Tenn.	Mn	Electrolytic
Kerr-McGee Chemical Corporation	Hamilton, Miss.	Mn	Electrolytic
Chemetals Corp.	Kingwood, W. Va.	Mn	Fused Salt Electrolysis
<u>Synthetic manganese dioxide</u>			
ESB Materials Co.	Covington, Tenn.	MnO ₂	Electrolytic
Kerr-McGee Chemical Corp.	Henderson, Nevada	MnO ₂	Electrolytic
Union Carbide Corp.	Marietta, Ohio	MnO ₂	Electrolytic
Shepherd Chemical Co.	Cincinnati, Ohio	MnO ₂	Chemical
Chemetals Corp.	Baltimore, Md.	MnO ₂	Chemical
General Metallic Oxides	Jersey City, N.J.	MnO ₂	Chemical

^a References 1,5

Note: This listing is subject to change as market conditions change, facility ownership changes, plants are closed, etc. The reader should verify the existence of particular facilities by consulting current listings and/or the plants themselves. The level of manganese emissions from any given facility is a function of variables such as capacity, throughput, and control measures, and should be determined through direct contacts with plant personnel.

REFERENCES FOR SECTION 4.3

1. Kirk-Othmer. Encyclopedia of Chemical Technology. Vol. 14. 3d Ed. John Wiley & Sons, Inc., New York. 1981.
2. Walsh, J. J., and J. P. Faunce. The Production of Manganese Metal. Presented at the 105th Annual Meeting of AIME in Las Vegas, Nevada, February 1976.
3. Nelson, T. P., et al. Study of Sources of Chromium, Nickel, and Manganese. Prepared by Radian Corporation for the Office of Air Quality Planning and Standards, U.S. Environmental Protection Agency, Research Triangle Park, North Carolina. October 1983.

4. U.S. Environmental Protection Agency. Compilation of Air Pollutant Emission Factors. AP-42, Supplement 14. May 1983.
5. Jones, T. S. Mineral Commodity Profiles. Manganese. Bureau of Mines, U.S. Department of the Interior. 1983.

4.4 PRODUCTION OF MANGANESE CHEMICALS

About 40 different manganese chemicals are manufactured in the United States. Most are low-volume chemicals. The ones with the largest volumes and the most significance are manganese sulfate (MnSO_4), manganese oxide (MnO), and potassium permanganate (KMnO_4). Of secondary importance are Maneb, MnCO_3 , and others.

The process descriptions for manganese chemical production focus on MnSO_4 , MnO , and KMnO_4 because of their large volume of production and higher potential for emissions.

4.4.1 Manganese Sulfate Process

Manganese sulfate is made by dissolving rhodochrosite ore or Mn (II) oxide in H_2SO_4 . It is also obtained as a byproduct of the manufacture of hydroquinone from aniline sulfate and MnO_2 (usually a MnO_2 ore). The direct production of MnSO_4 involves the use of MnO_2 or MnCO_3 ores and H_2SO_4 (to dissolve the ores). For a high-purity product, the solution is treated with MnO_2 for oxidation of Fe. The pH is adjusted to about 6.5 and the precipitated $\text{Fe}(\text{OH})_3$ and other impurities are filtered out. The MnSO_4 is recovered by evaporation of the solution. Manganese sulfate is used as an intermediate in the manufacture of many Mn Products, as an Mn fertilizer, as an animal feed additive, etc.¹

4.4.2 Manganese Oxide Process

Manganese (II) oxide (MnO) is an important precursor of many commercial manganese compounds, and it is used in fertilizer and feedstuff formulations. It is produced by reductive roasting of MnO_2

ores. The Chemetals process uses a stationary bed of crushed Mn ore (mm); the ore is continuously replenished from the top, and a reducing gas, CH_4 , and air are introduced from the bottom. The MnO is formed in a reaction zone immediately beneath the top layer, where the temperature is controlled to between 760° and 1040°C to avoid sintering. The MnO moves downward and finally passes through an inert atmosphere cooling zone. The MnO_2 is removed and ground to 200 mesh size. Other processes use rotary kilns or pile roasting for the reduction step.

4.4.3 Potassium Permanganate Process

Potassium permanganate is produced by several different processes. The only one-step process is based on the electrolytic conversion of ferromanganese to permanganate. The others begin with MnO_2 ore and involve two steps: thermal synthesis of potassium manganate followed by electrolytic oxidation of MnO_4^{2-} to MnO_4^- . Figure 4-7 presents an overview of the production of KMnO_4 by roasting and liquid-phase oxidation processes.

In the liquid phase oxidation process, pre-concentrated molten potassium hydroxide (70 to 80%) is placed in a reactor together with a quantity of 78 to 80 percent MnO_2 ore at a 1:5 ratio of $\text{MnO}_2:\text{KOH}$.¹ Enough air or O_2 is introduced below the liquid level to maintain a positive pressure of 186 to 216 kPa (1.9 to 2.2 atm). The temperature is kept at 250 to 320°C throughout the reaction period (4 to 6 hours). This process converts about 87 to 94 percent of the MnO_2 to K_2MnO_4 . The K_2MnO_4 product is then separated from the hot caustic metal by diluting it with recycled KOH of about a 10 to 12 percent concentration and allowing it to cool to 30 to 40°C . The K_2MnO_4 settles and is separated by centrifugation.

The Carus Chemical Company in LaSalle, Illinois (the only U.S. producer of potassium permanganate) uses a liquid-phase oxidation process. The process is similar to that described, but it is continuously operated and uses a special filtration technique to separate the K_2MnO_4 from the hot caustic melt (one that does not require dilution).¹

4.4.4 Emission Sources and Emission Factors

Because most of the operations in the manufacture of Mn chemicals are carried out in a wet state, emissions are not a

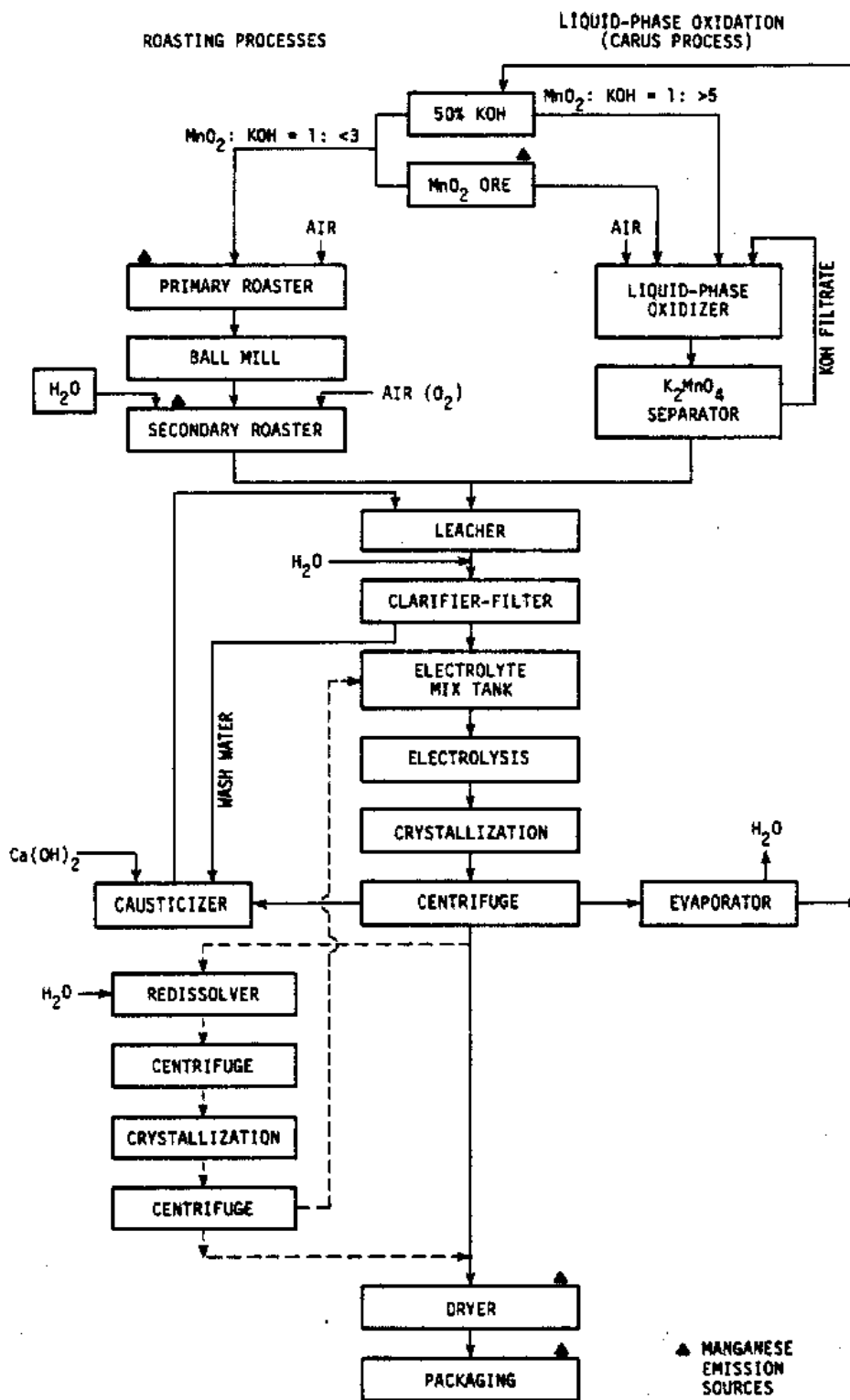

Figure 4-7. Production of $KMnO_4$: roasting and liquid phase oxidation processes.¹

problem; however, Mn-containing particulate emissions can occur from the drying, grinding, and roasting operations involving ores and other chemicals containing Mn. Also, fugitive emissions occur from materials handling and packaging. The possible emission sources of Mn are indicated in Figure 4-7.

Table 4-9 presents Mn emission factors for drying/grinding, roasting, and packaging/handling operations. The emission factors are calculated by multiplying the particulate emission factor by the average percentage of Mn in the materials.

TABLE 4-9. MANGANESE EMISSION FACTORS FOR THE MANUFACTURE OF MANGANESE CHEMICALS

Source processed	Control equipment	Particulate emissions factors, kg/Mg (lb/ton) of material processed	Manganese emission factors, kg/Mg (lb/ton) of material
Ore drying/grinding	Uncontrolled	9.9 (19.8) ^a	4.45 (8.9) ^b
	Fabric filters	0.0099 (0.0198)	0.0045 (0.009)
Ore roasting ^c	Uncontrolled	122 (245) ^d	55 (110) ^b
	Fabric filter	0.244 (0.49)	0.11 (0.22)
Packaging/handling of products	Uncontrolled	4.4 (8.8) ^a	^e
	Fabric filters	0.0044 (0.0088)	^e

^a Reference 2.

^b Mn content of ores used in chemical manufacture: 45% (Range 30-55%).

^c Many different roasting processes are used; this emission factor is for kiln-type roasting. (Assumed to be same as for cement manufacture).

^d Reference 3.

^e Extremely variable; depends on the Mn content of the product. For example, KMnO_4 is 34.8 percent manganese, MnO_2 is 63.2 percent manganese, and $\text{MnSO}_4 \cdot 7\text{H}_2\text{O}$ is 19.6 percent manganese. Manganese emissions would be determined by multiplying the particulate emission rate by the percent manganese in the product divided by 100.

Note: Mn may be present as oxide in the ore and evolved as Mn-bearing particulates during drying and grinding operations. During roasting, the Mn-bearing particulates may be in the form of oxides. Packaging and handling emissions will essentially be in the same chemical form as the material processed.

4.4.5 Source Locations

Table 4-10 indicates the locations of manganese chemical producers in the United States.

REFERENCES FOR SECTION 4.4

1. Kirk-Othmer. Encyclopedia of Chemical Technology. Vol. 14 3d Ed. John Wiley & Sons, Inc., New York. 1981.
2. Nelson, T. P., et al. Study of Sources of Chromium, Nickel, and Manganese. Prepared by Radian Corporation for the Office of Air Quality Planning and Standards, U.S. Environmental Protection Agency, Research Triangle Park, North Carolina. October 1983.
3. U.S. Environmental Protection Agency. Compilation of Air Pollutant Emission Factors. AP-42, Supplement 14. May 1983.
4. SRI International. 1982 Directory of Chemical Producers, U.S.A. Menlo Park, California. 1982.
5. Jones, T. S. Mineral Commodity Profiles. Manganese - 1983. Bureau of Mines, U.S. Department of Interior. 1983.

4.5 IRON AND STEEL PRODUCTION

Manganese enters the process of steel making as low-grade Mn ores charged to the blast furnace and as ferroalloys added to the refined steel. The three principal types of steelmaking furnaces used are open hearths (OH), basic oxygen furnaces (BOF), and electric arc furnaces (EAF). Iron ore fines, blast furnace flue dust, mill scale, and other iron-bearing materials generated in an integrated steel plant are often recycled to the sinter plant for agglomeration. All of these materials contain some manganese; consequently, blast furnaces, sinter plants, open hearths, basic oxygen furnaces, and electric arc furnaces are the main source of manganese emissions.

4.5.1 Blast Furnace Operations

Molten iron (hot metal) for steel production is obtained by reducing iron ore [Fe_2O_3 (Hematite) or Fe_3O_4 (Magnitite)] to iron in the blast furnace.

The blast furnace is a countercurrent, refractory-lined cylinder (Figure 4-8). Preheated air is introduced through a large number of water-cooled tuyeres at the bottom of the furnace, passes through

TABLE 4-10. DOMESTIC PRODUCERS OF MANGANESE CHEMICALS^a

Product	Producer	Location
Manganese acetate (manganese acetate)	C. P. Chems., Inc. Gulf Oil Corp. Harshaw Chemical Co., Subsidiary Industrial Chemicals Department The Hall Chemical Company	Sewaren, New Jersey Cleveland, Ohio Arab, Alabama Wickliffe, Ohio
	Mineral Research and Development Company The Shepherd Chemical Company	Concord, North Carolina Cincinnati, Ohio
Manganese acetate tetra- Carolina hydrate	National Starch and Chemical Corp. Proctor Chem. Co., Inc., Subsidiary	Salisbury, North
Manganese acetylacetonate (manganic and manganous acetylacetonate) (bis/2,4-pentanedionato/ manganese)	MacKenzie Chemical Works, Inc. MacKenzie INTERVAR The Shepherd Chemical Company	Bush, Louisiana Cincinnati, Ohio
Manganese benzoate	The Hall Chemical Company	Wickliffe, Ohio
Manganese borate (manganous borate)	General Metallic Oxides Company	Jersey City, New Jersey
Manganese boride	Union Oil Company of California Molycorp, Inc., Subsidiary Chemicals and Rare Earth Division	Washington, Pennsylvania
Manganese carbonate (manganous carbonate)	North American Phillips Corp. T H Agriculture and Nutrition Co., Inc. Crop Protection Division Leffingwell Chemical Company, Div. Richardson-Vicks, Inc. J. T. Baker Chemical Company, Subsidiary The Shepherd Chemical Company	Brea, California Phillipsburg, New Jersey Cincinnati, Ohio
Manganese carbonyl Massachusetts	Pressure Chemicals Company Strem Chemicals, Inc.	Pittsburgh, Pennsylvania Newburyport,
Manganese chloride (manganous chloride)	Allied Corp. Allied Chemical Company Chemetals Corp. Mineral Research and Development Corp. Richardson-Vicks, Inc. J. T. Baker Chemical Company, Subsidiary	Claymont, Delaware Curtis Bay, Maryland Concord, North Carolina Phillipsburg, New Jersey
Manganese difluoride	Pennwalt Corporation Chemical Group Ozark-Mahoning Company, Subsidiary	Tulsa, Oklahoma
Manganese 2-ethylhexanoate (also manganese octanoate, Jersey manganese octoate, manganous 2-ethylhexanoate, and man- ganous octanoate)	Ferro Corp.. Chemical Division Interstab Chemicals, Inc. Mooney Chemicals, Inc. The Shepherd Chemical Company Troy Chemical Corporation	Bedford, Ohio New Btunswick, New Franklin, Pennsylvania Cincinnati, Ohio Newark, New Jersey
Manganese formate	The Shepherd Chemical Company	Cincinnati, Ohio
Manganese gluconate (manganous gluconate)	Beca Products, Inc. Pfizer, Inc., Chemicals Division	Janesville, Wisconsin Brooklyn, New York
Manganese hydrate (manganic hydroxide)	General Metallic Oxides Company	Jersey City, New Jersey

TABLE 4-10 (continued)

Product	Producer	Location
Manganese hypophosphite (manganous hypophosphite)	Occidental Petroleum Corp. Hooker Chemicals Corp.. Subsidiary	Niagara Falls, New York
Manganese isocarboxylate	Mooney Chemicals, Inc.	Franklin, Pennsylvania
Manganese naphthenate (manganous naphthenate)	Ferro Corporation, Chemicals Division Interstab Chemicals, Inc. Mooney Chemicals, Inc. Tenneco, Inc. Tenneco Chemicals, Inc. Troy Chemical Corporation Witco Chemical Corporation Organics Division	Bedford, Ohio New Brunswick, New Jersey Franklin, Pennsylvania Elizabeth, New Jersey Newark, New Jersey Chicago, Illinois
Manganese (manganous) nitrate	Allied Corporation Allied Chemical Company Ashland Oil, Inc. Ashland Chemical Company, Subsidiary Speciality Chemicals Division Chemetals Corporation C. P. Chemicals, Inc. The Hall Chemical Company Mineral Research and Development Corp. The Shepherd Chemical Company	Claymont, Delaware Cincinnati, Ohio Easton, Pennsylvania Curtis Bay, Maryland Sumpter, South Carolina Arab, Alabama Concord, North Carolina Cincinnati, Ohio
Manganese oleate (linoleate)	Troy Chemical Corporation	Newark, New Jersey
Manganese oxide	American Minerals, Inc. Agricultural Division Chemetals Corporation Eagle-Pitcher Industries, Inc. Agricultural Chemicals Division Elkem Metals Company Phillipp Brothers Chemicals, Inc. The Prince Manufacturing Company	El Paso, Texas Philadelphia, Pa. Rosiclare, Illinois Curtis Bay, Maryland Cedartown, Georgia Marietta, Ohio Bowmanstown, Pa. Quincy, Illinois
Manganese pentacarbonyl bromide	Pressure Chemical Company	Pittsburgh, Pennsylvania
Manganese pentacarbonyl chloride	Pressure Chemical Company	Pittsburgh, Pennsylvania
Manganese stearate (manganous stearate)	The Norac Company, Inc. Mathe Division	Lodi, New Jersey
Manganese sulfide	Elkem Metals Company	Niagara Falls, New York
Manganese sulfate	Eagle-Pitcher Industrial, Inc. Agricultural Chemicals Division Eastman Kodak Company Eastman Chemicals Products, Inc. Subsidiary of Tennessee Eastman Company Richardson Yicks, Inc. J. T. Baker Chemical Company, sub- sidiary	Cedartown, Georgia Kingsport, Tennessee Phillipsburg, New Jersey

TABLE 4-10 (continued)

Product	Producer	Location
Manganese Tallate (manganous tallate, manganorns linoresinate)	Interstab Chemicals, Inc. Mooney Chemicals, Inc. The Shepherd Chemical Company Tenneco, Inc. Tenneco Chemicals, Inc. Troy Chemicals Corp.	New Brunswick, New Jersey Franklin, Pennsylvania Cincinnati, Ohio Elizabeth, New Jersey Newark, New Jersey
Manganese trifluoride (manganic fluoride)	Pennwalt Corp. Chemicals Group Ozark-Mahoning Company, subsidiary	Tulsa, Oklahoma
Potassium permanganate	Carus Corp. Carus Chemical Company, Division	LaSalle, Illinois

^a Reference 4.

Note: This listing is subject to change as market conditions change, facility ownership changes, plants are closed, etc. The reader should verify the existence of particular facilities by consulting current listings and/or the plants themselves. The level of manganese emissions from any given facility is a function of variables such as capacity, throughput, and control measures, and should be determined through direct contacts with plant personnel.

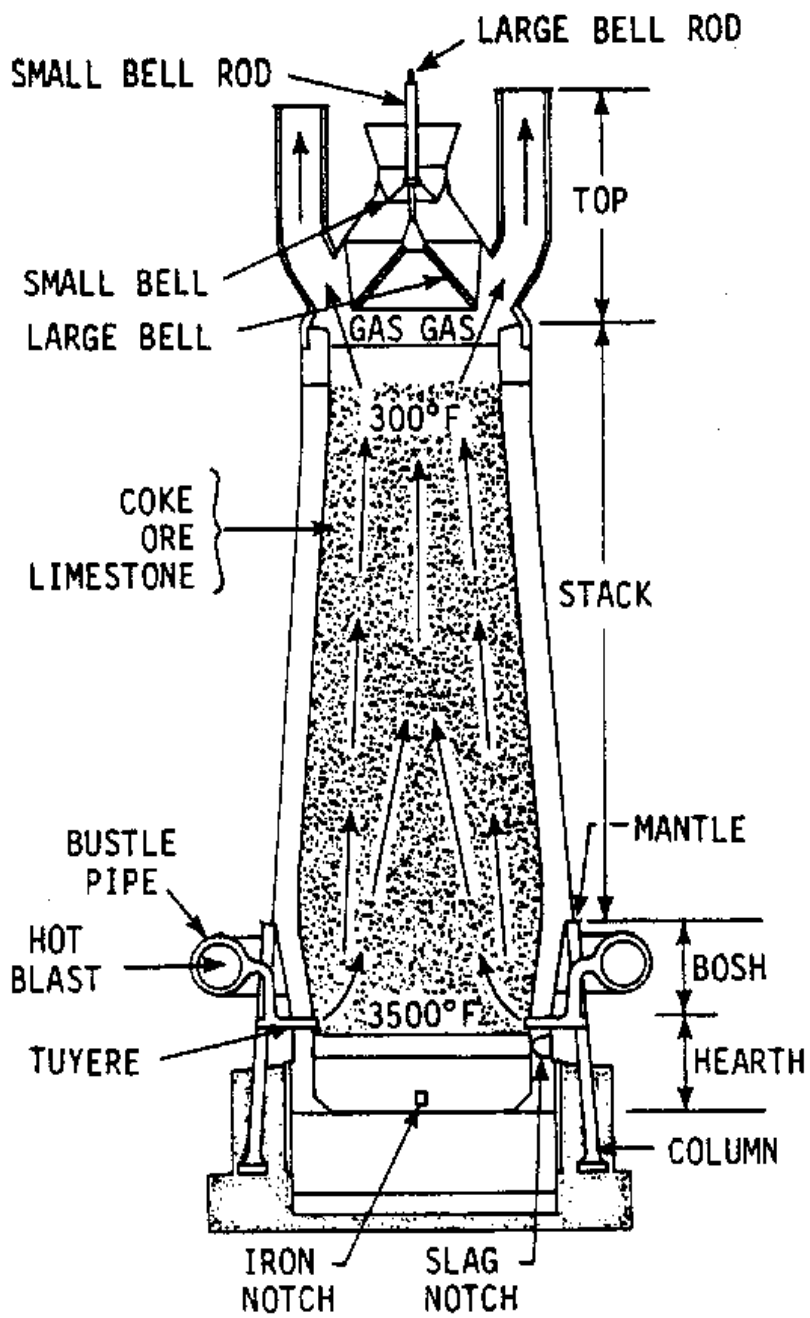

Figure 4-8. Cross-sectional view of a typical blast furnace.

the descending charge, and is exhausted at the top of the furnace. It takes an average charge of 1.7 unit weights of iron-bearing material, 0.55 unit weight of coke, 0.2 unit weight of limestone, and 1.9 unit weights of air to produce 1 unit weight of iron. Average blast furnace byproducts consist of 0.3 unit weight of slag, 0.05 unit weight of dust, and 3.0 unit weights of gas. Molten iron and slag accumulate in the hearth and are drained intermittently (continuously on very large furnaces) through runners to ladle cars that transport the hot metal to the steel making facilities. The slag is diverted to slag pots or directly to slag pits or slag granulators, depending on the facilities provided.

Dust-laden gases from the furnace are exhausted through a cyclone (dust catcher) and a one- or two-stage cleaning operation. The primary cleaner is normally a wet scrubber, which removes 90 percent of the remaining particulates.¹ The secondary cleaner is normally a high-energy wet scrubber (usually a venturi) or an electrostatic precipitator. After it is cleaned, the gas contains less than 0.05 gr/m³ (0.02 gr/ft³) of particulates.

Emissions and Emission Factors--

Manganese-bearing emissions occur during the storage and transfer of iron ore, sinter, and pellets to the blast furnace. Emissions also occur during the tapping and transfer of metal and slag within the casthouse (casthouse emissions). Conditions known as "slips" can cause emissions from the emergency pressure-release valves on top of the furnace, but these are rare in modern practice, occurring when the materials charged in the furnace do not move smoothly and thus leave a gas-filled space between two portions of the charge. When the unsettled section of the charge collapses, the sudden displacement of gas causes the exhaust gases, which contain manganese-bearing particulate, to exit from the emergency pressure-release valves. During tapping, emissions are produced when hot metal comes into contact with air. Dissolved gases are released and emissions emanate from both the slag and the metal.

Many blast furnace casthouses are uncontrolled. The most common control system comprises runner covers and pickup hoods vented to a fabric filter. Some plants are now using new systems that involve emission suppression techniques. These entail blanketing the molten iron with an inert gas to suppress oxidation. Table 4-11 indicates the manganese emissions from blast furnaces.

TABLE 4-11. MANGANESE EMISSIONS FROM IRON BLAST FURNACES

Source	Control device	Emission factors ^{a,b} kg/Mg (lb/ton) of iron
Blast furnace		
Slips	None	0.1185 (0.261)/slip ^c
Casthouse emissions	None	0.0009 (0.0018) ^d
	Runner covers and pickup hoods to fab- ric filter	0.00009 (0.00018) ^d

^a Reference 1.

^b Most of the manganese emissions are in the form of oxides.

^c Mn content of flue dust = 0.3 percent.

^d Mn content of the slag runner fumes = 0.2 percent.⁵ Mn content = 0.4 percent from the hot metal. It is assumed that the Mn content from the hot metal runners is the same as the Mn content of the dust from fabric filter controlling hot metal transfer.³

The manganese content of the raw materials used in ironmaking and byproducts are presented in Table 4-12.

TABLE 4-12. MANGANESE CONTENT OF RAW MATERIALS AND BYPRODUCTS OF BLAST FURNACE PRODUCTION^a

Raw Material or byproduct	Manganese content, %
Iron ore pellets	0.06 to 0.25
Iron ores	0.25 to 1 (0.3 average)
Manganese ores (manganiferous)	<5
BOF slag	2.1 to 4.9 (4 average)
Blast furnace hot metal	0.5 to 1.2 (0.75 average)
Blast furnace slag	0.2 to 1.0 (0.3 average)
Blast furnace flue dust	0.2 to 0.6 (0.3 average)

^a References 2, 3, and 4

Source Locations--

Table 4-13 lists the blast furnace operations in the United States.

4.5.2 Sintering Operations

Iron-bearing dusts, iron ore fines, mill scale, and sludges generated in an integrated steel plant operation are recycled to the sinter plant. Sinter is an agglomerated product of a size and strength suitable for blast furnace charging.⁷ Figure 4-9 presents a flow diagram of a typical sinter plant. The charge materials, consisting of suitable proportions of iron ore fines, BF flue dust, mill scale, return sinter fines, limestone fines, and coke breeze, are mixed with controlled amounts of water and fed to a pug mill or to a balling drum. The prepared burden is spread in a 12-inch layer over a continuous moving grate called the sinter strand. A burner hood above the front third of the sinter strand ignites the coke breeze in the mixture. Natural gas or fuel oil is used for these burners. Once ignited, the combustion is self-supporting and provides sufficient heat, 1300° to 1400°C (2400°-2700°F), to cause surface melting and agglomeration of the mix. On the underside of the sinter machine are wind boxes, which draw the combusted air through the sinter bed into a common duct to a particulate control device. The fused sinter is discharged at the end of the sinter machine, where it is crushed and screened; the undersized portion is recycled to the sinter mix. The sized sinter is cooled in open air by water sprays or by mechanical fans and then charged to the furnaces.

Emissions and Emission Factors--

In the sintering process emissions occur from the wind box exhaust, the discharge (sinter crusher and hot screen), the cooler, and the cold screens. Mechanical collectors are typically used for product recovery and initial cleaning of windbox exhaust. Secondary collectors that have been used to control wind box exhaust emissions include wet and dry electrostatic precipitators, fabric filters, scrubbers, and gravel bed filters.

Manganese emission factors are obtained by multiplying the particulate emission factors for sintering operations by the manganese content of the sinter. In a high-basicity sinter, the Mn content of 1.2 percent was measured. Table 4-14 presents Mn emission factors for sinter operations.

TABLE 4-13. LOCATIONS (BY STATE AND CITY) OF BLAST FURNACES
IN THE UNITED STATES^a

City/State	Company
Alabama	
Fairfield	U.S. Steel
Gadsden	Republic Steel
Colorado	
Pueblo	CF&I Steel
Illinois	
South Chicago	Interlake, Inc. U.S. Steel
Indiana	
Burns Harbor	Bethlehem Steel
Gary	U.S. Steel
East Chicago	Inland Steel J&L Steel
Kentucky	
Ashland	National Steel
Maryland	
Sparrows Point	Bethlehem Steel
Michigan	
Dearborn	Ford Motor Rouge Works
Ecorse	National Steel
Trenton	McLouth Steel
New York	
Buffalo	Republic Steel
Ohio	
Cleveland	J&L Steel Republic Steel
Lorain	J&L Steel
Middletown	Armco, Inc.
New Miami	Armco, Inc.
Portsmouth	Cyclops (Empire-Detroit Steel)
Steubenville	Wheeling-Pittsburgh Steel
Warren	Republic Steel
Youngstown	Republic Steel

TABLE 4-13 (continued)

City/State	Company
Pennsylvania	
Aliquippa	J&L Steel
Baddock	U.S. Steel
Bethlehem	Bethlehem Steel
Duquesne	U.S. Steel
Fairless	U.S. Steel
Monessen	Wheeling-Pittsburgh
Melville Island	Shanango, Inc.
Rankin	U.S. Steel
Sharon	Sharon Steel
Texas	
Houston	Armco, Inc.
Lone Star	Lone Star Steel
Utah	
Geneva	U.S. Steel
West Virginia	
Weirton	National Steel

^a Reference 6.

Note: This listing is subject to change as market conditions change, facility ownership changes, plants are closed, etc. The reader should verify the existence of particular facilities by consulting current listings and/or the plants themselves. The level of manganese emissions from any given facility is a function of variables such as capacity, throughput, and control measures, and should be determined through direct contacts with plant personnel.

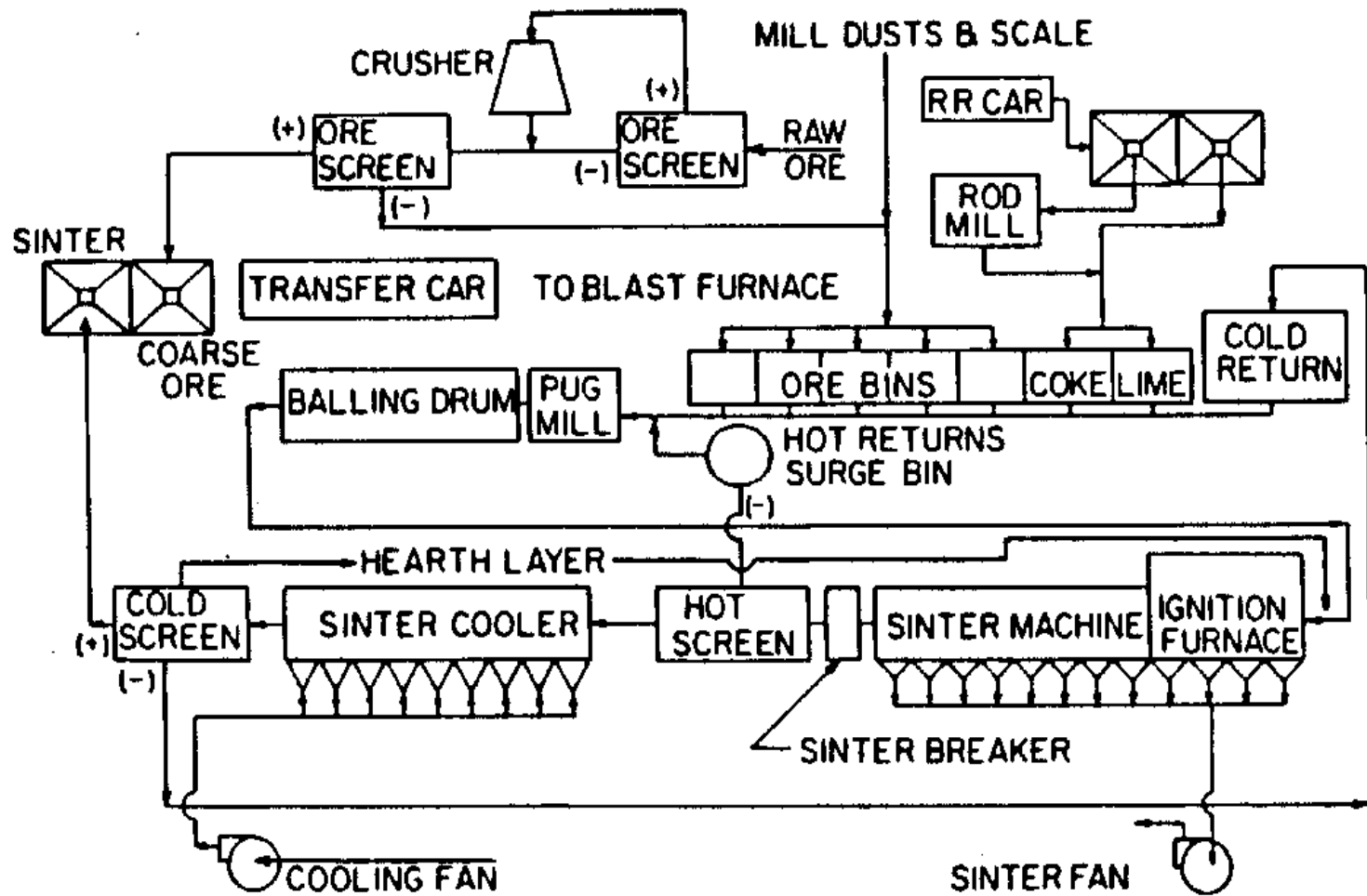

Figure 4-9. Schematic flow diagram of a typical sinter plant.

TABLE 4-14. MANGANESE EMISSION FACTORS FOR SINTERING OPERATIONS

Source	Control Equipment	Emissions factor ^{a,b}
		kg/Mg (lb/ton) of sinter
Sintering		
Windbox emissions	Uncontrolled	0.067 (0.134) ^c
	After coarse particle removal	0.052 (0.104)
	Dry ESP	0.0096 (0.0192)
	Wet ESP	0.001 (0.002)
	Scrubber	0.0028 (0.0056)
	Cyclone	0.006 (0.012)
Sinter discharge (breaker and hot screen)	Uncontrolled	0.04 (0.08)
	Fabric filter	0.0006 (0.0012)
	Orifice scrubber	0.0035 (0.007)
Windbox and discharge	Fabric filter	0.0018 (0.0036)

^a Reference 1.

^b Most of the manganese emissions are in the form of oxides.

^c Mn content of sinter = 1.2 percent.

Source Locations--

Sintering operations are generally part of the integrated steel plant operations. Table 4-15 lists the locations of sinter plants in the United States.

4.5.4 Open Hearth Furnace Operations

In the open hearth (OH) furnace, steel is produced from a charge of scrap and hot metal in varying proportions. The production of steel from OH furnaces is gradually being replaced by basic oxygen furnaces and electric arc furnaces. Steel production from OH furnaces accounted for 8.2 percent of the total steel production in 1982. No new OH furnaces are planned, and production is expected to continue to decline.

The OH furnace is heated alternately by a combustion flame from either end of the hearth. Figure 4-10 is a schematic of the OH furnace. The gas flow is reversed at regular intervals to recover the sensible heat from the combusted gases. This is accomplished by passing the gas through brick lattice work (checkers) at either end of the furnace and then into the gas cleaning system. At each reversal, the sensible heat in the brick is transferred to the incoming air. Oxidation reduces impurities such as C, Mn, Si, and P to specified levels. A slag layer is formed above the molten steel. Oxygen lancing is used to hasten the refining process. When the desired specifications of the steel are reached, the steel is drained through a tap hole into a ladle. Ferroalloys are added to the furnace and/or ladle as required. The molten steel is poured (teemed) into ingot molds for cooling and further processing.

Emissions and Emission Factors--

Sources of fugitive emissions from open hearth furnaces include charging, leakage from the furnace, tapping, and slag drainage. Tapping emissions can be controlled by ladle hoods vented to a control device. Very limited controls for fugitive emissions have been applied in open hearth steelmaking.

Emissions from open hearth furnaces are generally controlled with ESP's or wet scrubbers. Fabric filters have also been installed for particulate emissions control, but they require that the gases be pre-cooled.

TABLE 4-15. LOCATIONS (BY STATE AND CITY) OF SINTER PLANTS
IN THE U.S. INTEGRATED STEEL INDUSTRY^a

State/City	Company
Alabama	
Fairfield	U.S. Steel
Gadsden	Republic Steel
Colorado	
Pueblo	CF&I Steel
Illinois	
Granite City	National Steel
South Chicago	U.S. Steel
Indiana	
Burns Harbour	Bethlehem Steel
East Chicago	Inland Steel
	Jones & Laughlin Steel
Gary	U.S. Steel
Kentucky	
Ashland	ARMCO
Maryland	
Sparrows Point	National Steel
Michigan	
Ecorse	National Steel
Ohio	
Middletown	ARMCO
Youngstown	Republic Steel
Pennsylvania	
Aliquippa	J&L Steel
Bethlehem	Bethlehem Steel
Fairless	U.S. Steel
Monessen	Wheeling-Pittsburgh Steel
Saxonburg	U.S. Steel
Texas	
Lone Star	Lone Star Steel
Houston	ARMCO
Utah	
Geneva	U.S. Steel
West Virginia	
East Steubenville	Wheeling-Pittsburgh Steel
Weirton	Weirton Steel

^a Reference 6.

Note: This listing is subject to change as market conditions change, facility ownership changes, plants are closed, etc. The reader should verify the existence of particular facilities by consulting current listings and/or the plants themselves. The level of manganese emissions from any given facility is a function of variables such as capacity, throughput, and control measures, and should be determined through direct contacts with plant personnel.

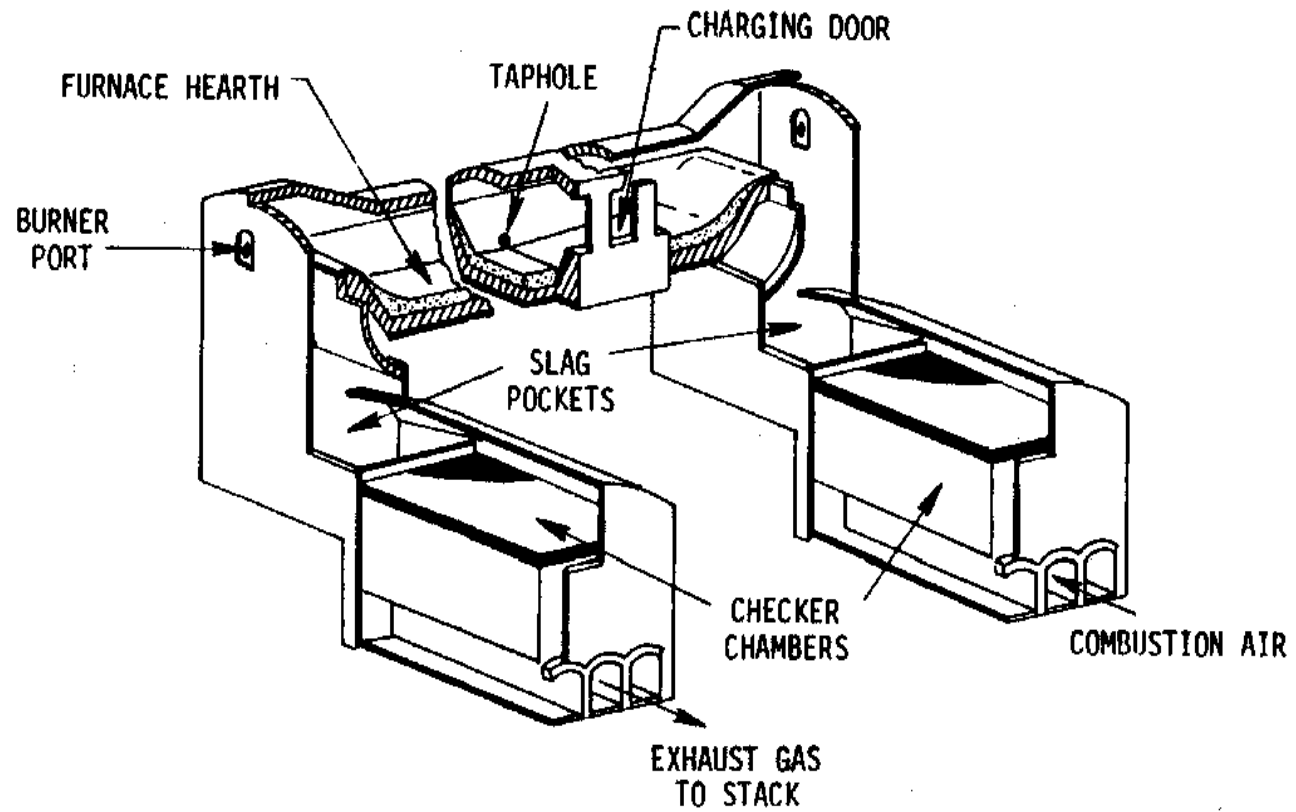

Figure 4-10. Schematic representation of an open hearth furnace.

Manganese emission factors are derived by multiplying the particulate emission factors for OH operations by the Mn content of the dust collected from an ESP. The measured Mn content of the dust is around 0.37 percent.³ Table 4-16 indicates the emission factors for Mn from open hearth furnaces.

TABLE 4-16. MANGANESE EMISSIONS FACTORS FOR OPEN HEARTH FURNACE OPERATIONS

Source	Control equipment	Emission factors, ^a kg/Mg (lb/ton) of pig iron
Melting and refining	Uncontrolled	0.039 (0.078) ^b
	ESP	0.0005 (0.001)
Roof monitor	Uncontrolled	0.0003 (0.0006)
Teeming	Uncontrolled	0.00013 (0.00026)
	Side-draft hood to fabric filter	0.000003 (0.000006)

^a Reference 1.1

^b Mn content of ESP dust = 0.37 percent.³ Most of the manganese emissions are in the form of oxides.

Location of Sources --

Table 4-17 lists plants with open hearth furnaces in the United States.

4.5.5 Basic Oxygen Furnace Operations

The BOF process (Figure 4-11) converts hot metal to steel in batches in around 45 minutes (depending on the size of the vessel). This process is superior to the older open-hearth process used in integrated steel operations. About 60 percent of U.S. steel was produced by this method in 1983.

A typical charge consists of 70 percent hot metal and 30 percent scrap. Commercially pure oxygen is blown into the vessel through a lance to oxidize the impurities and carbon. The oxidation generates the required heat to melt all the scrap charged. Lime is added to the vessel to form a slag that contains the oxidized impurities from the hot metal and scrap.

TABLE 4-17. LOCATIONS (BY STATE AND CITY) OF STEEL PLANTS
WITH OPEN-HEARTH FURNACES IN THE UNITED STATES^a

State/City	Company
Indiana	
East Chicago	Inland Steel
Maryland	
Sparrows Point	Bethlehem Steel
Ohio	
Middletown	ARMCO
Pennsylvania	
Fairless Hills	U.S. Steel
Homestead	U.S. Steel
Texas	
Lone Star	Lone Star Steel
Utah	
Geneva	U.S. Steel

^a Reference 6.

Note: This listing is subject to change as market conditions change, facility ownership changes, plants are closed, etc. The reader should verify the existence of particular facilities by consulting current listings and/or the plants themselves. The level of manganese emissions from any given facility is a function of variables such as capacity, throughput, and control measures, and should be determined through direct contacts with plant personnel.

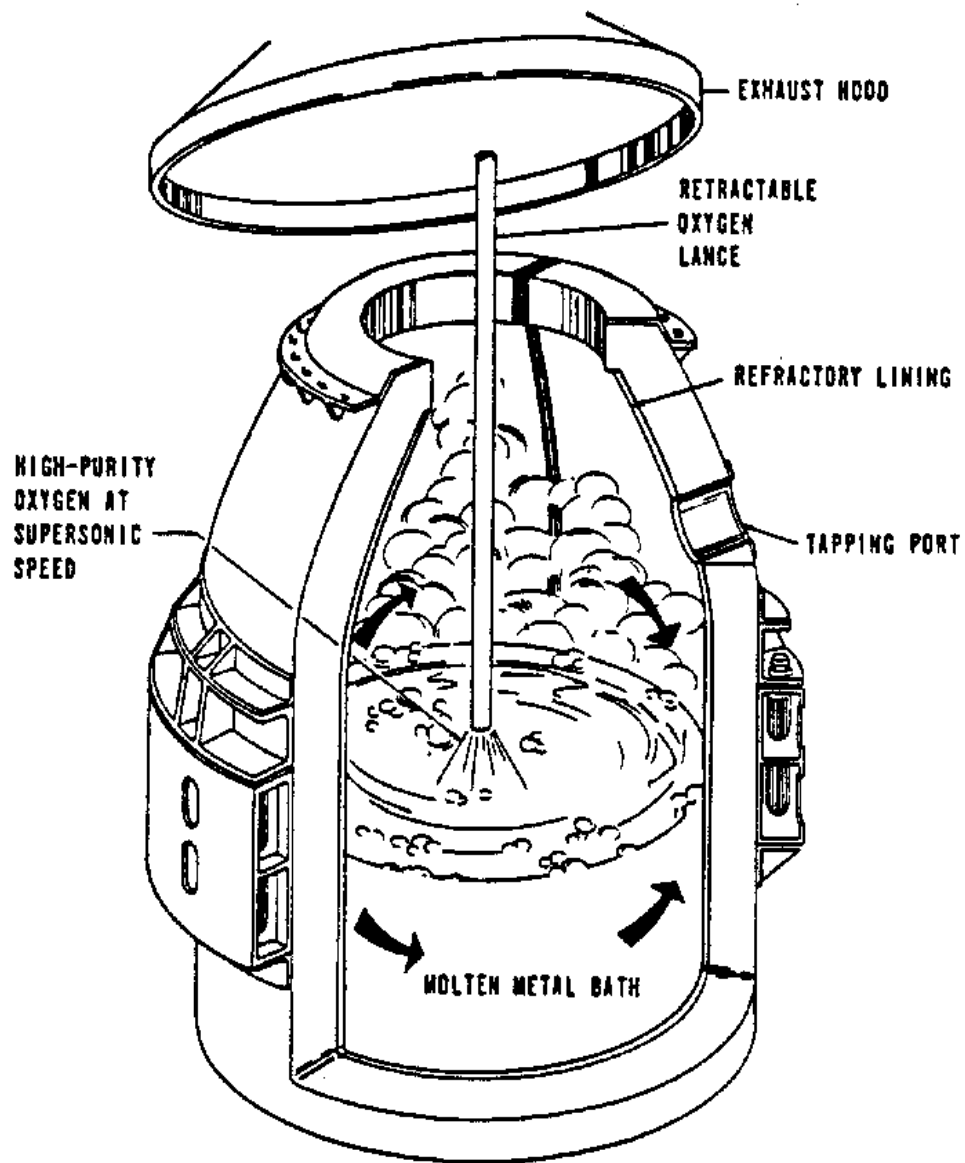

Figure 4-11. Basic oxygen process furnace.

The furnace is a large, open-mouthed vessel lined with basic refractories. The vessel is mounted on trunnions, which allow it to be rotated through 360 degrees.

Recent modifications entail many new configurations of oxygen entry into the vessel. In the Q-BOP process, the required oxygen is blown through tuyeres at the bottom of the vessel. A relatively new process, known as the KMS process^{0iis} is used in one plant, in which oxygen is introduced both from the top and through bottom and side nozzles.

The large quantities of carbon monoxide (CO) produced by the reactions in the BOF can be combusted at the mouth of the vessel, cooled, and then vented to gas-cleaning devices (open-hood system), or the combustion can be suppressed at the furnace mouth (closed hood system). The volume of gases to be handled in a gas-cleaning device for closed-hood systems is substantially lower than that for open-hood systems.

Although most of the furnaces installed before 1975 are of the open-hood design, new furnaces are being designed with closed hoods.

After the oxygen blowing step, the metal is tapped into a ladle, to which deoxidizers and alloying elements are added. The slag is poured into a slag pot or onto the ground.

Emissions and Emission Factors--

The primary emissions during oxygen blowing range from 20 to 50 lb/ton steel. The gas is vented to either an ESP or a venturi scrubber. In the closed-hood configuration, high energy, variable-throat, venturi scrubbers are used to clean the gas. The clean gas, which contains CO, is flared at the stack.

Emissions occur during the transfer of hot metal from the ladle cars to the ladles, the charging of scrap and hot metal to the BOF vessel, slag dumping, and tapping of the steel. Hot metal transfer is controlled by close-fitting hoods evacuated to a fabric filter. Secondary controls used to control the charging and tapping emissions may evacuate emissions to a separate fabric filter or to the primary emission control system. The Q-BOP furnaces are generally completely enclosed to control emissions.

Calculations of the manganese emission factors are based on the Mn content of the particulate emissions. Analysis of BOF dust shows 1.2 percent Mn.³ The Mn content in the raw materials entering and products exiting the BOF process are shown in Table 4-18.

TABLE 4-18. MANGANESE CONTENT OF RAW MATERIALS
AND PRODUCTS OF BOF PROCESS^a

Raw material or byproduct	Mn content, %
Steel scrap	Variable (0.5 average)
Hot metal	0.5 to 1.2 (0.75 average)
Reladling fabric filter dust	0.24 to 0.28 (0.25 average)
BOF slag	2.1 to 4.9 (4 average)
ESP dust	0.8 to 1.3 (1.0 average)

^a Reference 3.

These figures only represent a general range; individual plant data may be quite different.

Table 4-19 presents calculated Mn emission factors for the BOF process.

Source Locations--

Table 4-20 indicates the BOF locations in the United States.

4.5.6 Electric Arc Furnace Operations

In 1982, electric arc furnaces accounted for 31.3 percent of total steel production in the United States.⁹ This share is expected to reach 36 percent by 1990. The electric arc furnace is a refractory-lined steel cylinder with a bowl-shaped hearth and a dome-shaped removable roof. Many of the new furnaces have water-cooled side panels and a water-cooled roof. Three carbon electrodes extended through holes in the roof reach the charge in the furnace. The furnace roof and electrodes can be lifted and swung aside for charging of scrap. The furnace can be tilted for tapping the molten steel and removing the slag. Steel scrap is charged from the top by means of a special drop bottom bucket or a clam shell bucket. After the charge, the roof is swung back into position and the electrodes are lowered into the furnace. Melting of the scrap is accomplished by the heat of resistance of the metal between the arc paths. Oxyfuel burners may be used to hasten the melting. Oxygen lancing is done to increase the melting rate of scrap. Required fluxes (lime) are either added along with the charge or by pneumatic injection.

TABLE 4-19. MANGANESE EMISSION FACTORS FOR BASIC OXYGEN FURNACE OPERATIONS

Source	Control equipment	Emission factors ^{a,b}
		kg/Mg (lb/ton) of steel
Top-blown BOF melting and refining	Uncontrolled	0.1425 (0.285) ^c
	Controlled by open hood vented to:	
	ESP	0.0065 (0.013)
	Scrubber	0.0045 (0.009)
	Controlled by closed hood vented to scrubber	
Q-BOP melting and refining	Scrubber	0.00028 (0.00056)
Charging		
At source	Uncontrolled	0.003 (0.006)
At building monitor	Uncontrolled	0.00071 (0.00142)
Tapping		
At source	Uncontrolled	0.0046 (0.0092)
At building monitor	Uncontrolled	0.00145 (0.0029)
Hot metal transfer		
At source	Uncontrolled	0.0002 (0.0004) ^d
At building monitor	Uncontrolled	0.00007 (0.00014)
BOF monitor		
All sources	Uncontrolled	0.0025 (0.005)

^a Reference 1

^b Most of the manganese emissions are in the form of oxides.

^c Mn content = 1.0 percent of the BOF dust and sludge. (Range 0.8 to 1.3 percent, Reference 3.

^d Mn content = 0.26 percent; based on Reladling Baghouse Dust Analysis in Reference 3.

TABLE 4-20. LOCATIONS (BY STATE AND CITY) OF BASIC OXYGEN FURNACES
IN THE IRON AND STEEL INDUSTRY IN THE UNITED STATES^a

State/City	Company
Alabama	
Fairfield	U.S. Steel Corporation
Gadsden	Republic Steel corporation
Colorado	
Pueblo	CF&I Steel Corporation
Illinois	
Chicago	Interlake, Inc.
Granite City	National Steel Corporation
South Chicago	Republic Steel Corporation
	U.S. Steel Corporation
Indiana	
Burns Harbor	Bethlehem Steel Company
East Chicago	Inland Steel Company
	Jones and Laughlin Steel Corporation
Gary	U.S. Steel Corporation
Kentucky	
Ashland	Armco Steel Corporation
Maryland	
Sparrows Point	Bethlehem Steel Corporation
Michigan	
Dearborn	Ford Motor Company
Ecorse	National Steel Corporation
Trenton	McLouth Steel Corporation
New York	
Buffalo	Republic Steel Corporation
Ohio	
Cleveland	Jones and Laughlin Steel Corporation
	Republic Steel Corp oration
Lorain	U.S. Steel Corporation
Middletown	Armco Steel Corporation
Steubenville	Wheeling-Pittsburgh Steel Corporation
Warren	Republic Steel Corporation
Pennsylvania	
Aliquippa	Jones and Laughlin Steel Corporation
Bethlehem	Bethlehem Steel Company
Braddock	U.S. Steel Corporatlon
Duquesne	U.S. Steel Corporation
Farrell	Sharon Steel Corporation
Midland	Crucible, Incorporated
Monessen	Wheeling-Pittsburgh Steel Corporation
Natrona	Allegheny Ludlum Steel Company
West Virginia	
Weirton	Weirton Steel

^a Reference 6.

Note: This listing is subject to change as market conditions change, facility ownership changes, plants are closed, etc. The reader should verify the existence of particular facilities by consulting current listings and/or the plants themselves, The level of manganese emissions from any given facility is a function of variables such as capacity, throughput, and control measures, and should be determined through direct contacts with plant personnel.

Ultra-high-power (UHP) furnaces use larger electrodes and allow more power input to the charge and thus a faster melting rate.

After the proper chemistry and temperature of the bath are achieved, the furnace is tilted and the steel is poured into a ladle. Ferroalloys are added in the ladle. After tapping, the steel may be degasified by several means, or other ladle operations, such as stirring, may be performed. Continuous casters then cast the steel. Figure 4-12 is a schematic diagram of EAF operations.

In stainless steel production, the molten steel is transferred from the electric furnace to an Argon oxygen deoxidation (AOD) vessel similar to the BOF. Argon and oxygen and/or nitrogen are blown into the steel for preferential removal of carbon instead of oxidation of chromium (Cr), the principal alloying element in stainless steel. Because the yield of Cr is high in this process, it is more economical.

Emissions and Emission Factors--

Electric arc furnace emissions are classified as process or fugitive. Emissions generated at the furnace during periods when the furnace roof is closed (e.g., during melting and refining) are classified as process emissions. Emissions generated during periods when the furnace roof is open (e.g., during charging) or when the furnace is tilted (e.g., during tapping) are classified as fugitive emissions.⁷

Process emissions from the meltdown operation consist of metallic and mineral oxide particulate generated from the vaporization of iron and the transformation of mineral additives, as well as some carbon monoxide and hydrocarbons. Trace constituents (including manganese) are emitted in particulate form from EAF's. During the melting process, emissions escape through electrode holes, the slag door, and other furnace openings.

Charging emissions may contain particulate, carbon monoxide, hydrocarbon vapors, and soot. During tapping, fumes consisting of iron and other oxides are generated from the alloys that are added to the ladle.

Fabric filters are the most widely used control devices on EAF's. Wet scrubbers are used on less than 2 percent of the existing EAF units in the United States, and only one shop uses an ESP unit to control EAF dust.⁷

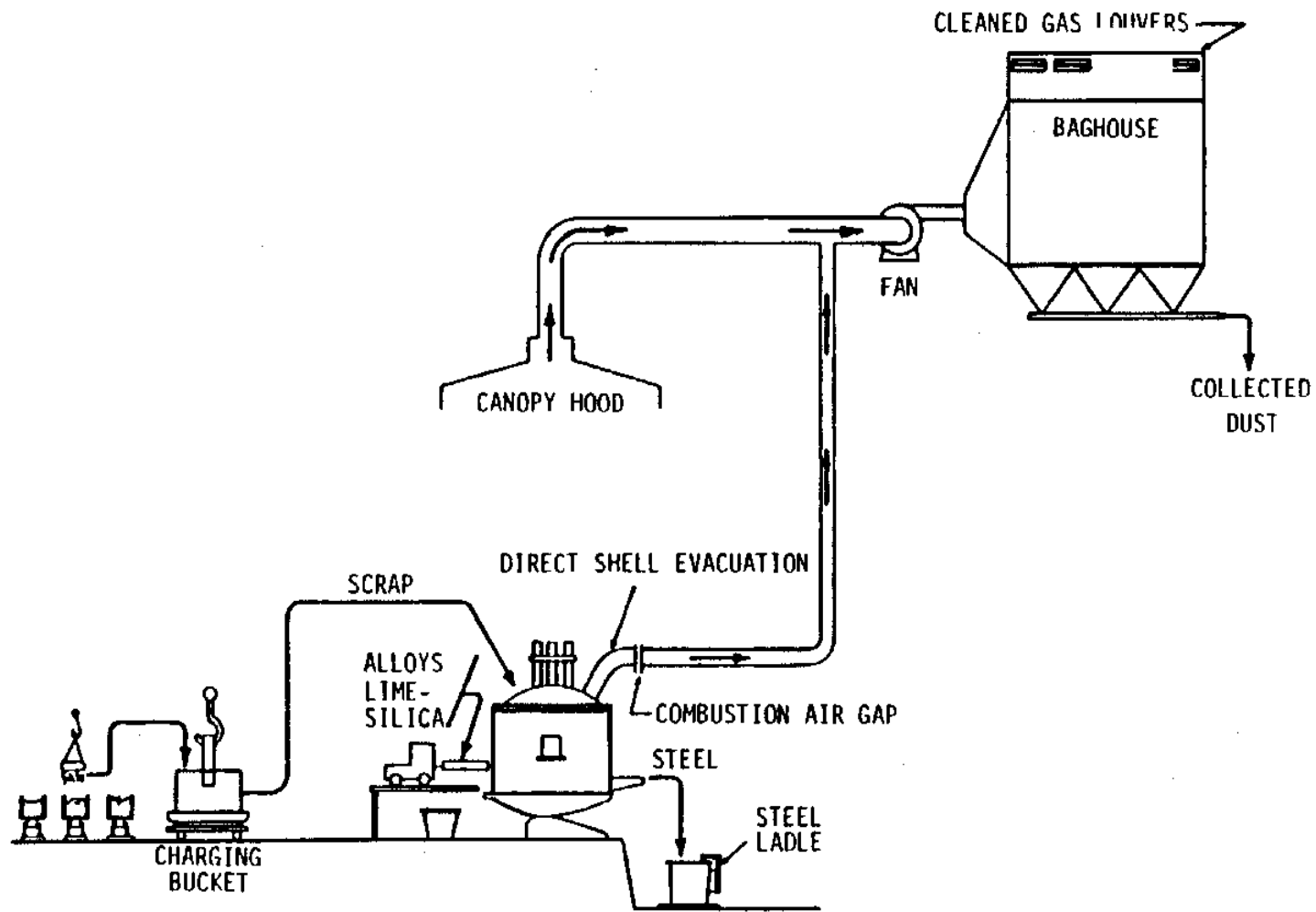

Figure 4-12. Schematic of electric arc furnace process.

Evacuation systems of various configurations are adopted to capture both primary and secondary emissions in EAF shops.

- " Direct-shell evacuation control system (DEC)
- " Side-draft hood
- " Canopy hood
- " Partial furnace enclosure (PFE)
- " Total furnace enclosure (TFE)
- " Tapping hood
- " Scavenger duct system
- " Roof monitor
- " Building evacuation

The DEC and canopy hood (shown in Figure 4-12) are the most common.

The manganese emission factors are calculated based on the Mn content of the particulate emissions. The following are analyses of manganese content in EAF dust generated in the production of various types of steel.¹⁰

Stainless steel and alloy	-	4.92% (average of 6 samples)
Mixed products including stainless and/or specialty alloys	-	3.25% (average of 6 samples)
Low and medium alloy	-	5.76% (1 sample)
Carbon and alloy	-	4.0% (average of 7 samples)
Carbon steel	-	3.48% (average of 10 samples)

Manganese content of electric arc furnace slag also varies with the type of steels made. The average Mn content is around 4 percent.³

Table 4-21 presents manganese emission factors for electric arc furnace operations.

Source Locations--

Table 4-22 lists the locations of EAF shops in the United States.

TABLE 4-21. MANGANESE EMISSION FACTORS FOR ELECTRIC ARC FURNACE OPERATIONS

Source	Control equipment	Emission factors ^{a,b}
		kg/Mg (lb/ton) of product
Melting and refining carbon steel	Uncontrolled	0.665 (1.33) ^c
Roof monitor emissions (charging, tapping, and slagging)	Uncontrolled	0.0245 (0.049)
Melting, refining, charging, tapping, and slagging		
Carbon steel	Uncontrolled	0.875 (1.75)
	DEC plus charging hood to common fabric filter	0.00075 (0.0015)
Alloy steel	Uncontrolled	0.328 (0.656) ^d
	Total building evacuation to fabric filter	0.0087 (0.0174)

^a Reference 1.

^b Most of the manganese emissions are in the form of oxides.

^c Mn content of EAF dust--carbon steel, 3.48 percent (average of 10 samples).¹¹

^d Mn content of EAF dust--low and medium alloy, 5.76 percent.¹¹

TABLE 4-22. ALPHABETICAL LISTING (BY COMPANY NAME) OF
ELECTRIC ARC FURNACE/LOCATIONS IN THE UNITED STATES^a

Plant/location	Plant/location	Plant/location
AL Tech Specialty Steel Corp., Watervliet, New York	B.W. Steel, Chicago Heights, Illinois	Cyclops Corp. ° Empire Detroit Steel Division, Mansfield, Ohio
Allegheny Ludlum Steel Corp., Brackenridge, Pennsylvania Steel	Cabot Corporation Stellite Division, Kokomo, Indiana	Universal Cyclops Specialty Bridgeville, Pennsylvania
ARMCO, Inc. ° Baltimore Works, Baltimore, Maryland	Cameron Iron Works, Inc. Cypress, Texas	Earle M. Jorgensen Company, Seattle, Washington
° Butler Works, Company, Butler, Pennsylvania	Carpenter Technology Corp., ° Steel Division Bridgeport, Connecticut	Eastern Stainless Steel Baltimore, Maryland
° Houston Works, Houston, Texas	° Reading Plant, Reading, Pennsylvania	Edgewater Steel Corp. Oakmont, Pennsylvania
° Kansas City Works, Kansas City, Missouri	Cascade Rolling Mills McMinnville, Oregon	Electralloy Corp., Oil City, Pennsylvania
° Marion Works, Marion, Ohio	The CECO Corporation ° Lemont Manufacturing Company Lemont, Illinois	Finkle & Sons Company, Chicago, Illinois
° Sand Springs Works Sand Springs, Oklahoma	CF&I Steel Corp. Pueblo, Colorado	Florida Steel Corp. ° Charlotte Mill Charlotte, North Carolina
Atlantic Steel Company ° Atlanta Works, Atlanta, Georgia	Champion Steel Corp., Orwell, Ohio	° Baldwin Mill, Baldwin, Florida
° Cartersville Works, Cartersville, Georgia	Chaparral Steel Co., Midlothian, Texas	° Tampa Mill, Tampa, Florida
Auburn Steel Company, Auburn, New York	Charter Electric Melting, Inc. Chicago Heights, Illinois	Ford Motor Steel Division, Dearborn, Michigan
Babcock & Wilcox Company, Beaver Falls, Pennsylvania	Columbia Tool Steel Company Chicago Heights, Illinois	Georgetown Steel Division, Georgetown, South Carolina
Bayou Steel Corporation, New Orleans, Louisiana	Connors Steel Co., ° Birmingham Works, Birmingham, Alabama	Georgetown Texas Steel Corp. Beaumont, Texas
Bethlehem Steel Corp. ° Bethlehem Plant, Bethlehem, Pennsylvania	° Huntington Works Huntington, West Virginia	Green River Steel, Owensboro, Kentucky
° Steel ton Plant, Steelton, Pennsylvania	Continental Steel Co., Kokomo, Indiana	Hawaiian Western Steel Ltd., Eva, Hawaii
° Johnstown Plant, Johnstown, Pennsylvania	Copperweld Steel Co., Warren, Ohio	Hurricane Industries, Sealy, Texas
° Los Angeles Plant, Los Angeles, California	Crucible, Inc. ° Stainless Steel Division, Midland, Pennsylvania	Ingersol Johnson Steel Company, New Castle, Indiana
° Seattle Plant, Seattle, Washington	° Specialty Metals Division Syracuse, New York	Ingersol Rand-Oil Field Prod., Pampa, Texas
Border Steel Mills, Inc. El Paso, Texas		Inland Steel Company, East Chicago, Indiana
Braeburn Alloy Steel Division Lower Burrell, Pennsylvania		Intercoastal Steel Corp., Chesapeake, Virginia
Interlake, Inc. Hoaganaes Corporation Gallatin, Tennessee	National Forge Company ° Erie Plant Erie, Pennsylvania	Roanoke Electric Steel Corp. Roanoke, Virginia
ITT Harper Morton Grove, Illinois	° Irvine Forge Division Irvine, Pennsylvania	Roblin Steel Company Dunkirk Works, Dunkirk, New York

(Continued)

Table 4-22 (continued)

Plant/location	Plant/location	Plant/location
Jackson Mill, Jackson, Tennessee	National Steel Great Lakes Steel Division Ecorse, Michigan	Ross Steel Works Amlto, Louisiana
Jessop Steel Company Washington Works Washington, Pennsylvania	New Jersey Steel & Structure Corp. Sayerville, New Jersey	Sharon Steel Corp. Sharon, Pennsylvania
Jones & Laughlin Steel Corp. ◦ Cleveland Works Cleveland, Ohio	Newport Steel, Newport, Kentucky	Simonds Steel Division, Wallace Murray Corp., Lockport, New York
◦ Pittsburgh Works California Pittsburgh, Pennsylvania	North Star Steel Company ◦ St. Paul Plant, St. Paul, Minnesota	Soule Steel Company, Carson Works, Carson,
◦ Warren Works, Warren, Michigan	◦ Monroe Plant, Monroe, Michigan	Standard Steel Burnham, Pennsylvania
Joslyn Stainless Steels, Fort Wayne, Indiana	◦ Wilton Plant, Wilton, Iowa	Structural Metals, Inc., Sequin, Texas
Judson Steel Corp., Emeryville, California	Northwest Steel Rolling Mills, Inc., Kent, Washington	Teledyne Vasco, Latrobe, Pennsylvania
Kentucky Electric Steel Company, Ashland, Kentucky	Northwestern Steel & Wire Sterling, Illinois	Tennessee Forging Steel Corp. ◦ Harriman Works, Harriman, Tennessee
Keystone Consolidated Industries, Inc. Keystone Group Steel Works Peopria, Illinois	NUCOR Corp. Darlington Mill, Darlington, South Carolina	Tennessee Forging Steel Corp. ◦ Newport Works Newport, Arkansas
Knoxville Iron Company Knoxville, Tennessee	◦ Jewett Mill, Jewett, Texas	Texas Steel Company, Fort Worth, Texas
Laclede Steel Company, Alton, Illinois	◦ Norfolk Mill, Morfolk, Nebraska	Timkin Company ◦ Steel and Tube Division Canton, Ohio
Latrobe Steel Latrobe, Pennsylvania	◦ Plymouth Mill, Plymouth, Utah	Torrence Plant, Torrence, California
Latrobe Works Latrobe, Pennsylvania	Owens Electric Steel Company, Cayce, South Carolina	Union EYectric Steel Corp. Burgettstown, Pennsylvania
Lonestar Steel Company, Lone Star, Texas	Phoenix SteelCorp. ◦ Plate Division Claymont, Delaware	United States Steel Corp. ◦ Fairless Works, Fairless Hills, Pennsylvania
Lukens Steel, Coatsville, Pennsylvania	Quantex Corp. MacSteel Division Jackson, Michigan	◦ Johnstown Works, Johnstown, Pennsylvania
MacSteel Division Ft. Smith, Arizona	Raritan River Steel Company Perth Amboy, New Jersey	◦ National Duquesne Works, Duquesne, Pennsylvania
Marathon Le Tourneau Company, Tempe, Arizona	Republic Steel Corp. ◦ Central Alloy Works Canton, Ohio	◦ South Works, South Chicago, Illinois
McClouth Steel Corp . Trenton, Michigan	◦ Republic Steel Corp.	◦ Texas Works, Baytown, Texas
Mississippi Steel Division Flowood Works, Flowood, Mississippi Pennsylvania	South Chicago Works, South Chicago, Illinois	Washington Steel Company, Fitch Works, Houston,

*Reference 6.

Note: This listing is subject to change as market conditions change, facility ownership changes, plants are closed, etc. The reader should verify the existence of particular facilities by consulting current listings and/or the plants themselves. The level of manganese emissions from any given facility is a function of variables such as capacity, throughput and control measures, and should be determined through direct contacts with plant personnel.

REFERENCES FOR SECTION 4.5

1. U.S. Environmental Protection Agency. Compilation of Air Pollutant Emission Factors. AP-42, Supplement 14. May 1983.
2. Strassburger, J. H. (Ed.) Blast Furnace - Theory and Practice. Vol. 1. Gordon and Breach Science Publishers, 1969.
3. Calspan, et al. Assessment of Industrial Hazardous Waste Practices in the Metal Smelting and Refining Industry. Vol. IV. U.S. Environmental Protection Agency. 1977.
4. Fornacht, D. R. Characterization and Utilization of Steel Plant Fines. Presented at the First Symposium on Iron and Steel Pollution Abatement Technology, Chicago, October 1979. EPA-600/9-80-012.
5. Kelly, J. F., and A. W. Simon. Characterization of Slag Emissions at a Blast Furnace Casthouse. Presented at the EPA/AISI Symposium at Chicago, Illinois, October 1983.
6. World Steel Industry Data Handbook. 33 Metal Producing. Volume 5, U.S.A. McGraw-Hill, New York. 1982.
7. U.S. Environmental Protection Agency. Control Techniques for Particulate Emissions From Stationary Sources. Vol. 2. EPA-450/3-81-005b, September 1982.
8. Balajee, S. R., and G. A. Walton. Investigations of the Effect of Sintering Process Variables on Super-Fluxed Sinter Production and Quality. In: Proceedings of Iron Making Symposium, Toronto, Ontario, 1981. Volume 40, published by the Iron and Steel Society of AIME.
9. Hogan, W. T. The Expanding Electric Furnace: A Threat to the BOF? Iron and Steel Engineer, October 1983.
10. Lehigh University. Characterization, Recovery, and Recycling of Electric Arc Furnace Dusts. Prepared for U.S. Department of Commerce. Bethlehem, Pennsylvania. February 1982.

4.6 IRON AND STEEL FOUNDRIES

Figure 4-13 presents a generalized flow diagram for iron and steel foundries. The raw materials flow, sand preparation for the molds, and core preparation are similar in both iron and steel foundries. Three major types of furnaces are used in both: cupolas, induction furnaces, and electric arc furnaces. About 70 percent of all iron is produced in cupolas. A major portion of the remainder is

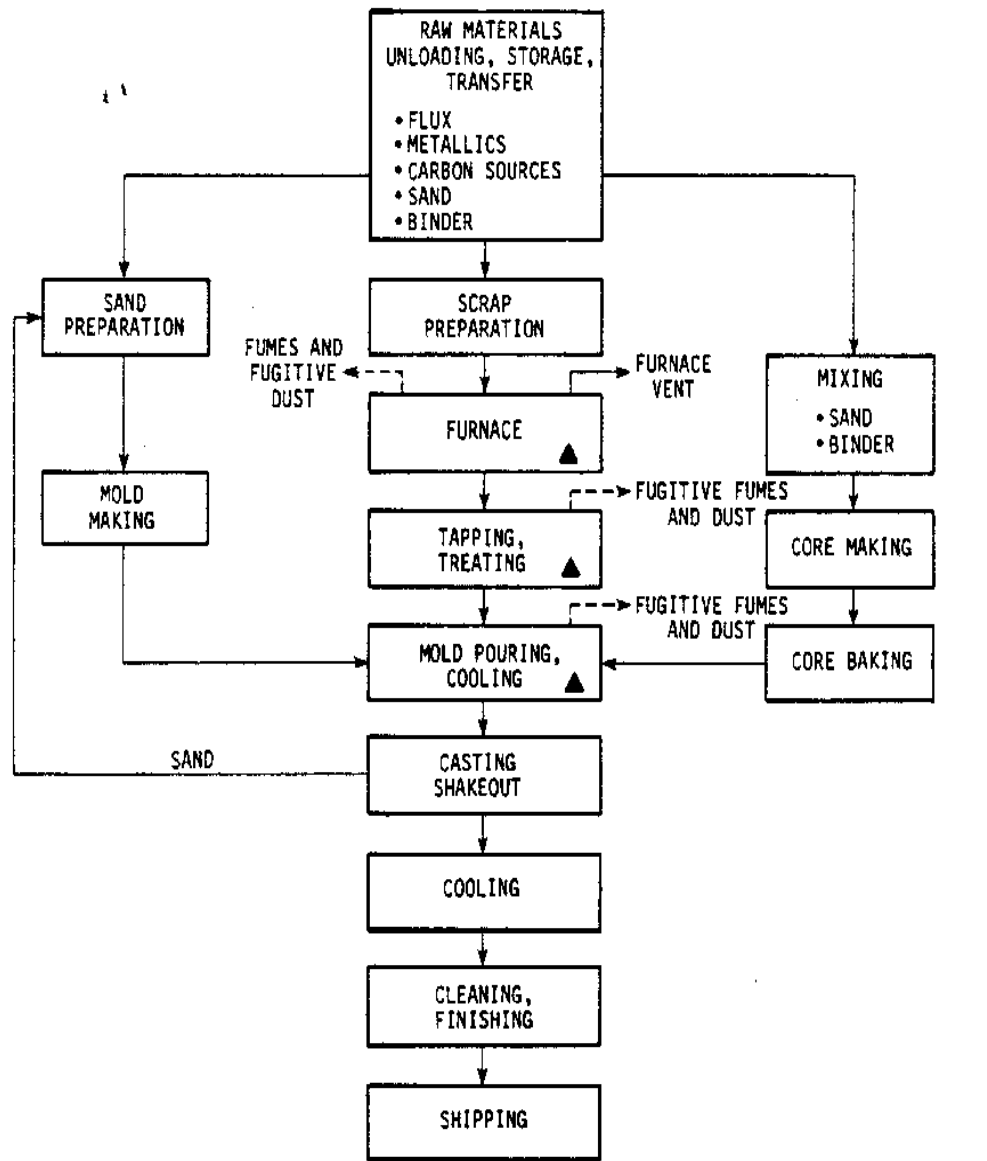

Figure 4-13. Generalized flow diagram of iron/steel foundry.

Source: Reference 1.

produced in electric arc and induction furnaces. A small percentage of melting in gray iron foundries takes place in air furnaces, reverberatory furnaces, pot furnaces, and indirect arc furnaces.¹ Steel foundries rely almost exclusively on EAFs or induction furnaces; open hearth furnaces and induction furnaces are used infrequently.¹

Raw material handling operations include receiving, unloading, storage, and conveying all raw materials to the foundry. The raw materials, which include pig iron, iron scrap, steel scrap, foundry returns, ferroalloys, fluxes, additives, sand, sand additives, and binders, are stored in both open and enclosed areas.

4.6.1 Cupolas

The cupola furnace is the major furnace used in a gray iron foundry. It is typically a vertical, refractory-lined, steel shell, which is charged at the top with alternate layers of pig iron, coke, and flux. The larger cupolas are water-cooled. Air for combustion of coke is introduced at the bottom, and the heat generated melts the charge. Hot-blast cupolas use preheated air. Typical melting capacities range from 0.9 to 25 Mg (1 to 27 tons) per hour, and a few units approach 90 Mg (100 tons) per hour.¹ Cupolas can be tapped either continuously or intermittently from a side tap hole at the bottom of the furnace.

4.6.2 Electric Arc Furnaces

Electric arc furnaces used in foundries are the same as those used in integrated steel plants described in Section 4.5.6.

4.6.3 Induction Furnaces

Induction furnaces are vertical refractory-lined cylinders surrounded by electrical coils energized with alternating current. The resulting fluctuating magnetic field heats and melts the metal. Induction furnaces are kept closed except during charging, skimming, and tapping operations. Tapping is done by tilting the furnace and pouring the molten metal through a hole in the side. Induction furnaces are also used to hold and superheat the charge after melting and refining has been done in other furnaces.

The basic melting process operations are 1) furnace charging, in which metal, scrap, alloys, carbon, and flux are added to the

furnace; 2) melting; 3) backcharging, which is the addition of more metal; 4) refining; 5) slag removal; and 6) tapping into a ladle or directly into molds.

4.6.4 Casting and Finishing

When the melting process is complete, the molten metal is tapped and poured into a ladle. In iron foundries the molten metal may be treated by the addition of magnesium to produce ductile iron and by the addition of soda ash or lime to remove sulfur. Sometimes graphite is added to adjust carbon levels. In steel foundries, the molten steel may be further treated by alloy additions, degasification, and other operations. The treated molten metal is then poured into molds and allowed to cool partially. The partially cooled castings are placed on a vibrating grid, where the mold and core sand is shaken away from the casting.

In the cleaning and finishing process, burrs, risers, and gates are broken off or ground off to match the contours of the castings; the castings are then shot-blasted to remove remaining mold sand and scale.

4.6.5 Emissions and Emission Factors

Particulate emissions can occur during all of the operations just discussed. Figure 4-13 indicates the major manganese emissions sources. The highest concentration of furnace emissions occurs during charging, backcharging, alloying, slag removal, and tapping operations, when the furnace lids and doors are opened. Emissions generated during the melting and refining operations are vented directly to a collection and control system. Controls for fugitive furnace emissions involve the use of roof hoods or special hoods in proximity to the furnace doors and tapping ladles.

High-energy scrubbers and bag filters with respective efficiencies greater than 95 percent and 98 percent are used to control particulate emissions from cupolas and electric arc furnaces. Induction furnaces are usually uncontrolled. ¹

The calculated emission factors for manganese, which are based on the Mn content in the particulate matter, are presented in Table 4-23 and Table 4-24 for iron and steel foundries, respectively.

TABLE 4-23. MANGANESE EMISSION FACTORS FOR IRON FOUNDRIES

Source	Control equipment	Emission factors ^{a,b} kg/Mg (lb/ton) of iron
Cupola	Uncontrolled	0.13 (0.25) ^c Range, 0.045-0.215 (0.09 - 0.43)
	Wet cap	0.06 (0.12)
	Impingement scrubber	0.0375 (0.075)
	High energy scrubber	0.006 (0.012)
	Fabric filter	0.0015 (0.003)
Electric arc furnace	Uncontrolled	0.075 (0.15) ^d Range, 0.045 - 0.15 (0.09 - 0.30)
	Fabric filter (99%)	0.00075 (0.0015)
Induction furnace	Uncontrolled	0.01125 (0.0225) ^e

^a Reference 1.

^b Most of the manganese emissions are in the form of oxides.

^c Mn content in cupola dust = 1.5 percent (range of 1 to 2%).³

^d Mn content in EAF dust = 1.5 percent.²

^e Mn content assumed to be 1.5 percent (as in cupola and EAF dust).

TABLE 4-24. MANGANESE EMISSION FACTORS FOR STEEL FOUNDRIES

Source	Control equipment	Emission factors ^a kg/Mg (lb/ton) of steel
Electric arc furnace	Uncontrolled	0.26 (0.52) ^b Range, 0.08 - 0.8 (0.16 - 1.6)
	ESP (95% efficiency)	0.013 (0.026)
	Venturi scrubber (97.5% efficiency)	0.0065 (0.013)
	Fabric filter (98.5% efficiency)	0.0004 (0.0008)
Induction furnace	Uncontrolled	0.002 (0.004) ^c

^a Reference 1.

^b Mn content in EAF dust = 4 percent (average of seven carbon and alloy steel plants)⁴.

^c Mn content assumed to be 4 percent (same as EAF dust).

4.6.6 Source Locations

In 1978, a total of 2,728 foundries were producing iron and steel castings throughout the United States. A high concentration of these foundries were located east of the Mississippi. The following is a breakdown of the type of castings produced by these foundries.2

Gray iron	-	1400	foundries
Ductile iron	-	590	foundries
Malleable iron	-	107	foundries
Steel	-	631	foundries

REFERENCES FOR SECTION 4.6

1. U.S. Environmental Protection Agency. Compilation of Air Pollutant Emission Factors. AP-42, Supplement 14. May 1983.
2. U.S. Environmental Protection Agency. Electric Arc Furnaces in Ferrous Foundries - Background Information for Proposed Standards. EPA-450/3-80-020a, May 1980.
3. Nelson, T. P., et al. Study of Sources of Chromium, Nickel, and Manganese. Prepared by Radian Corporation for the Office of Air Quality Planning and Standards, U.S. Environmental Protection Agency, Research Triangle Park, North Carolina. February 24, 1984.
4. Lehigh University. Characterization, Recovery, and Recycling of Electric Arc Furnace Dusts. Prepared for the U.S. Department of Commerce. Bethlehem, Pennsylvania. February 1982.

4.7 BATTERY MANUFACTURING

In the present-day dry cells, the cathode is MnO_2 with about 10 to 30 percent by weight carbon added to improve the conductivity. The collector for the cathode is usually either a carbon rod or a metal rod coated with carbon. The anode is usually the zinc can or zinc sheet. The electrolyte used is generally either a saturated solution of ammonium chloride, NaOH or KOH.

Batteries that use a saturated solution of ammonium chloride as the electrolyte are known as Leclanche, cells (after their inventor). The batteries that use NaOH or KOH as the electrolytes are known as alkaline cells. Alkaline cells generally perform better than Leclanche, cells. The alkaline manganese dioxide-zinc cell is essentially the same as the Leclanche, system except for the electrolyte used. These cells have a better shelf life, good low-temperature performance, and longer operating lives.

The Mn ore or synthetic oxides used in the manufacture of dry cell batteries are generally received in bags already ground to the required sizes. The bags are stored and covered with plastic covers. The bags are manually dumped into storage hoppers. The material handling systems are provided with pickup hoods at all transfer points and evacuated to a fabric filter.* In the subsequent steps, the MnO₂ powder is combined with the electrolyte and densified, and the rest of the process is conducted under semiwet conditions.

4.7.1 Emissions and Emission Factors

The only emission sources during dry battery manufacture are at the points of initial handling of the Mn-ore or MnO₂ powders. In the case of natural ores, grinding and screening may be done at these points, depending on the onsite facilities. These points are generally well controlled by the use of hoods evacuated to fabric filters. The manganese content in the ore powder handling area is monitored regularly, and the values are found to be lower than the permitted limits.

4.7.2 Source Locations

Some of the principal manufacturers of Leclanche and MnO₂-Zn dry cells in the United States are Bright Star Industries, Burgess Battery Company, ESB Polaroid, Marathon Battery Company, Ray-O-Vac Company, and Union Carbide Corporation.² Primary battery manufacturers, both dry and wet, are listed under SIC Code 3692.

* Personal communication from Union Carbide Corporation personnel at Cleveland, Ohio. Table 4-25 presents the Mn emission factors for battery manufacturing.

TABLE 4-25. MANGANESE EMISSION FACTORS IN BATTERY MANUFACTURE^a

Source	Control equipment	Manganese emission factors, ^b kg/Mg (lb/ton) of material processed
Ore grinding	Uncontrolled	15.0 (30.0)
	Fabric filter (99.9% efficiency)	0.015 (0.03)
Screening	Uncontrolled	0.5 (1.0)
	Fabric filter (99.9% efficiency)	0.0005 (0.001)
Storage and handling	Uncontrolled	2.2 (4.4)
	Fabric filter (99% efficiency)	0.0022 (0.0044)

^a Reference 1.

^b Mn content of the ores = 50 percent (range = 48 to 53%). Manganese is present as MnO₂. Pure MnO₂ is 63.2 percent manganese.

REFERENCES FOR SECTION 4.7

1. Nelson, T. P., et al. Study of Sources of Chromium, Nickel, and Manganese. Prepared by Radian Corporation for the Office of Air Quality Planning and Standards, U.S. Environmental Protection Agency, Research Triangle Park, North Carolina. February 24, 1984.
2. Kirk-Othmer. Encyclopedia of Chemical Technology. Vol. 14. 3d Ed. John Wiley & Sons, New York. 1981.

SECTION 5
INDIRECT SOURCES OF MANGANESE

5.1 COAL AND OIL COMBUSTION

Manganese emissions from combustion processes depend on the manganese content of the fuel fired. The distribution of manganese between boiler fly ash and bottom ash and the manganese content in fine fly ash are two very important factors that influence atmospheric emissions of manganese.

Manganese concentrations in coal range from 5 to 240 ppm and are typically around 25 ppm.¹ Table 5-1 shows the manganese concentrations and ash contents of several U.S. coals. Manganese concentrations in crude oil are much lower, ranging from 0.005 to 1.45 ppm and averaging 0.21 ppm for U.S. crude oils.² The manganese content in residual fuel oils in the United States averages about 0.16 ppm. The manganese content of distillate oil is reported to be lower than 0.01 ppm from some refineries.³ Table 5-2 shows the typical manganese content of several U.S. crude oils.

The fate of trace elements from the combustion process can be classified by one of three categories:

Class I. Approximately equal distribution between fly ash and bottom ash.

Class II. Preferential distribution in the fly ash.

Class III. Discharge to the atmosphere primarily as vapors.

Many studies on coal combustion have indicated that manganese emissions from this source generally fall under Class I.⁴ In a study correlating trace element emissions from hot-side and cold-side precipitators at coal-fired plants, however, manganese was found to be more concentrated in the fly ash from the cold-side station (i.e., Class II behavior).⁵ Manganese emissions from oil combustion generally fall into Class II, primarily because little bottom ash is formed in the oil combustion process.

TABLE 5-1. MANGANESE CONCENTRATIONS IN U.S. COALS^a

Coal type (source)	Manganese levels in coal, ppm	Ash content of coal, %
Appalachian (Pennsylvania, Maryland, Virginia, West Virginia, Ohio, Eastern Kentucky, Tennessee, Alabama)	5-55	6.2-18.3
Interior Eastern (Illinois, Indiana, Western Kentucky)	6-181	3.3-17.3
Interior Western (Iowa, Missouri, Kansas, Oklahoma, Arkansas)	108	25.9
Northern Plains (Montana, North Dakota, South Dakota)	88-101	11.3-15.8
Southwestern (Arizona, New Mexico, Colorado, Utah)	6-240	6.6-13.7

^a Reference 4.TABLE 5-2. MANGANESE CONCENTRATIONS IN U.S. CRUDE OILS^a

Oil Source	Manganese concentrations in oil, ppm
Arkansas	0.12
California	0.14
Colorado	0.21
Kansas	0.01
Montana	0.005
New Mexico	0.02
Oklahoma	0.03
Texas	0.03
Utah	1.45
Wyoming	0.04

^a Reference 2.

The size distribution of manganese concentrations in the fly ash is an important consideration because this determines the efficiency of particulate capture. Table 5-3 shows the particle size distribution of airborne fly ash measured at a coal-fired power plant. The results reveal a slight tendency for increased manganese concentrations in the finer fly ash fractions. Table 5-4 shows measured overall manganese particulate collection efficiencies for various types of air pollution control devices. As shown, fabric filters have high manganese collection efficiencies.

TABLE 5-3. PARTICLE SIZE DISTRIBUTION OF MANGANESE
IN FLY ASH FROM COAL COMBUSTION^a

Particle diameter, μm	Manganese concentration, ppm
11.3	150
7.3-11.3	210
4.7-7.3	230
3.3-4.7	200
2.06-3.3	240
1.06-2.06	470

^a Measured by X-ray fluorescence spectrometry; Reference 5.

TABLE 5-4. MANGANESE PARTICULATE COLLECTION EFFICIENCIES OF VARIOUS
TYPES OF CONTROL DEVICES

Source	Control device type	Overall manganese collection efficiency, %	Reference
Coal-fired utility boiler	Electrostatic precipitator	94.2	6
Coal-fired utility boiler	Fabric filter	99.8	7
Coal-fired industrial boiler	Wet scrubber	98.1	8
Oil-fired industrial boiler	Wet scrubber	83.3	9

5.1.1 Emission Factors

Manganese emissions from boilers are a function of the fuel type, furnace type (or firing configuration), and type of control device used. Table 5-5, Table 5-6, Table 5-7, and Table 5-8 present emission factors for manganese from coal- and oil fired combustion in utility, industrial, commercial/institutional, and residential boilers, respectively. These emission factors are based on an extensive survey of the existing literature.⁹ As with all emission factors, these are only general guidelines, and emissions from specific sources may vary considerably.

5.1.2 Source Locations

Information on individual source locations is available through the American Boiler Manufacturers Association, the Electric Power Research Institute, and data bases maintained by the U.S. Environmental Protection Agency and the U.S. Department of Energy.

REFERENCES FOR SECTION 5.1

1. Edwards, L. O., et al. Trace Metals and Stationary Conventional Combustion Processes. Vol. 1 EPA-600/7-80-155a, August 1980.
2. Anderson, D. Emission Factors for Trace Substances. EPA-450/2-73-001, December 1973.
3. Letter from E. D. Blum of Union Oil to T. Lahre of EPA, January 31, 1985.
4. Ray, S. S., and F. G. Parker. Characteristics of Ash From Coal-Fired Power Plants. EPA-600/7-77-010, January 1977.
5. Mann, R. M., et al. Trace Elements of Fly Ash: Emissions From Coal-Fired Steam Plants Equipped With Hot-Side and Cold-Side Electrostatic Precipitators for Particulate Control. EPA-908/4-78-008, December 1978.
6. Ensor, D. S., et al. Evaluation of the George Neal No. 3 Electrostatic Precipitator. EPRI FP-1145, August 1979.
7. Ensor, D. S., et al. Kramer Station Fabric Filter Evaluation. EPRI CS-1669, January 1981.
8. Leavitt, C., et al. Environmental Assessment of Coal- and Oil-Firing in a Controlled Industrial Boiler. Vol. II. EPA-600/7-78-164b, August 1978.
9. Krishnan, E. R., and G. V. Hellwig. Trace Emissions From Coal and Oil Combustion. Environmental Progress. Vol. 1, No. 4. November 1982. pp. 290-296.

TABLE 5-5. EMISSION FACTORS FOR MANGANESE FROM COAL AND OIL COMBUSTION:
UTILITY BOILERS^a

Fuel type	Furnace type	Control device	Manganese emission factor, pg/J ^b
Bituminous coal	Pulverized, dry-bottom	Electrostatic precipitator	41.3
		Scrubber	48.2
		None	98.0
	Pulverized, wet-bottom	Electrostatic precipitator	33.5
		Cyclone	Electrostatic precipitator Scrubber None
	Stoker	Multicyclones	47.3
	Anthracite coal	Pulverized	Electrostatic precipitator
Stoker		Multicyclones	47.3
Lignite coal	Pulverized, dry-bottom	Electrostatic precipitator	18.1
	Pulverized wet-bottom	Electrostatic precipitator	14.7
		Cyclone	Electrostatic precipitator Multicyclones
	Stoker	Multi cyclones	47.3
	Residual oil	Tangential	Electrostatic precipitator
None			11.0
Wall		Electrostatic precipitator	2.2
		None	11.0

^a Reference 9.

^b Picograms per joule of heat input to boiler; to convert from pg/J to lb/10¹² Btu, multiply by 2.33.

TABLE 5-6. EMISSION FACTORS FOR MANGANESE FROM
COAL AND OIL COMBUSTION: INDUSTRIAL BOILERS^a

Fuel type	Furnace type	Control device	Manganese emission factor, pg/J ^b
Bituminous coal	Pulverized	Multicyclones	29.4
		Scrubber	6.3
	Stoker	Multicyclones	47.3
Residual oil	Tangential	Scrubber	1.3
		None	6.5
	Wall	Scrubber	1.3
		None	6.5

^a Reference 9.

^b Picograms per joule of heat input to the boiler; to convert from pg/J to lb/10¹² Btu, multiply by 2.33.

TABLE 5-7. EMISSION FACTORS FOR MANGANESE FROM COAL AND OIL COMBUSTION:
COMMERCIAL/INSTITUTIONAL BOILERS^a

Fuel type	Furnace type	Control device	Manganese emission factor, pg/J ^b
Bituminous coal	Stoker	None	111
Residual oil	All	None	6.5
Distillate oil	All	None	0.6

^a Reference 9.

^b Picograms per joule of heat input to the boiler; to convert from pg/J to lb/10¹² Btu, multiply by 2.33.

TABLE 5-8. EMISSION FACTORS FOR MANGANESE FROM COAL
AND OIL COMBUSTION: RESIDENTIAL BOILERS^a

Fuel type	Furnace type	Control device	Manganese emission factor, pg/J ^b
Bituminous coal	All	None	2150
Anthracite coal	All	None	66.2
Lignite coal	All	None	430
Distillate oil	All	None	0.6

^a Reference 9.

^b Picograms per joule of heat input to the boiler; to convert from pg/J to lb/10¹² Btu, multiply by 2.33.

5.2 CEMENT PRODUCTION

Cement production is a potential source of manganese emissions because manganese can be a component of the raw materials and because manganese-containing fuels (e.g., coal and oil) are burned in the process kilns and dryers. In 1981, approximately 67.6 million Mg (75.1 million tons) of cement was produced in the United States. The manufacture of portland cement accounts for about 98 percent of this total. Hydraulic cement, which includes portland, natural, masonry, and pozzolan cements, is listed under SIC Code 3241.

Two methods are used for cement manufacture. In the dry method, feed materials are sent to the process as dry solids. In the wet method, feed materials are mixed with water and sent to the process as a slurry. Of the total domestic cement output, about 42 percent or 28.4 million Mg (31.2 million tons) is produced by the dry method and roughly 58 percent or 39.2 million Mg (43.9 million tons) is produced by the wet method. The basic process flow diagram for cement production by the wet and dry methods is shown in Figure 5-1.

The raw materials used to make cement fall into four basic categories: lime, silica, alumina, and iron. Approximately 1600 kg (3520 lb) of dry raw materials are required to produce 1 Mg (1.1 ton) of cement.

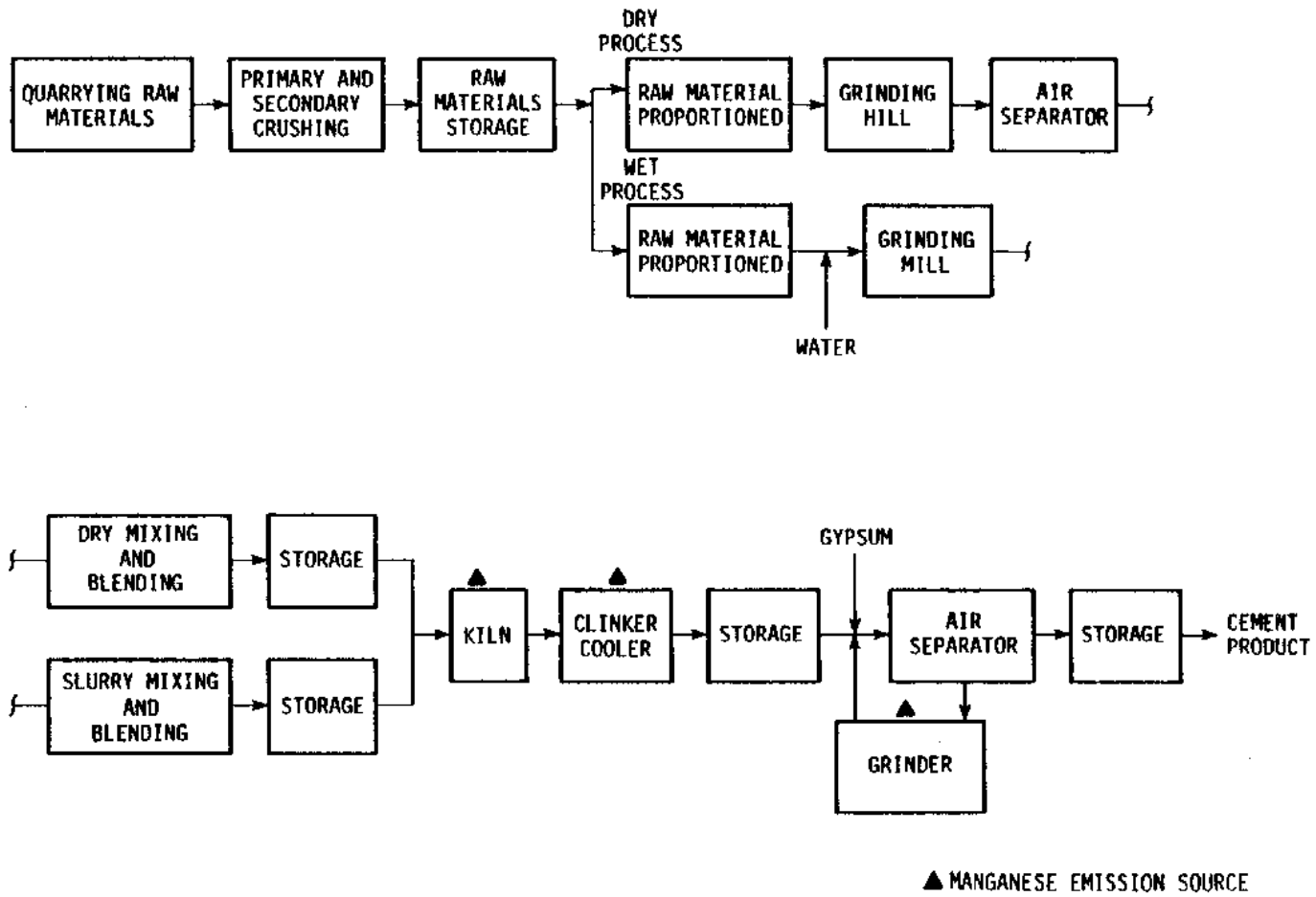

Figure 5-1. Basic process flow diagram for wet and dry cement production.

The quarried raw materials are crushed to a suitable size before they enter either the wet or dry processing loop. Regardless of the type of process used, the materials are proportioned, ground to a finer size, and blended before the primary cement production steps are begun.

In the dry process, the moisture content of the raw material is reduced to less than 1 percent either before or during the grinding operation. The dried materials are ground to a powder, blended to the prescribed proportion, and fed directly into an inclined rotary kiln. The powdered raw materials are fed into the upper end of the kiln and travel slowly to the lower end. The kilns are fired from the lower end, and the hot gases pass upward and through the raw materials. Drying, decarbonating, and calcining occur as the material travels through the heated kiln and finally fuse to form what is known as clinker. The clinker is then cooled, mixed with about 5 percent gypsum by weight, and ground to a final product size. The product is then stored for packaging and shipment.

In the wet process, a slurry is made by adding water to the raw materials prior to the initial proportioning and grinding. Excess water is then removed and the slurry is blended, mixed, and adjusted to achieve the proper composition. This homogeneous mixture (which is fed to the kilns) is usually either a slurry of 30 to 40 percent moisture or a wet filtrate of about 20 percent moisture. Wet process kilns are usually longer than dry process kilns, as water must be evaporated in the first part of the kiln. The remaining steps (kiln burning, clinker cooling, and gypsum addition) are the same as those in the dry process.

The dry process is more fuel-efficient because less energy is needed to evaporate the water before clinker formation. Most new plants use the dry process.

5.2.1 Emissions and Emission Factors

Manganese emissions consist largely of manganese-containing particulate originating from the raw materials; however, particulate and manganese emissions generated by fuel combustion are also present. The major manganese emission source is the rotary kiln. Lesser amounts are emitted from grinding mills and the clinker cooler. In the initial grinding stage, emissions are higher at dry-process plants than at wet-process plants.

Most plants in the cement industry use controls such as

multicyclones, ESP's, ESP's with cyclones, and fabric filters. Both fabric filters and modern ESPs have particulate removal efficiencies in excess of 99 percent. Multicyclones are about 80 percent efficient. In 1979, the New Source Performance Standards based on 99 percent removal efficiency were being met by 96 percent of the new sources.¹

Few direct measurements of manganese emissions from cement plants have been made; however, total particulate emissions from each stage of the process have been reported in References 1 and 3, and the manganese content of emissions (References 1 and 2) has also been measured. The Mn content of kiln dust measured varies widely. Two reported values are 130 ppm (Reference 1) and 900 ppm (Reference 2). All of these values were used to calculate the emission factors shown in Table 5-9.

TABLE 5-9. MANGANESE EMISSION FACTORS FOR CEMENT PLANTS^a

Emission Source	Control	Mn emissions factor, ^a Kg/10 ³ Mg (lb/10 ³ tons) of cement produced
Dry process		
Kiln	Uncontrolled	61 (122)
	ESP	0.0105 - 0.0625 (0.021 - 0.125)
	Fabric filter	0.0065 - 0.062 (0.013 - 0.124)
Dryers and grinders	Uncontrolled	24 (48)
Wet process		
Kilns	Uncontrolled	57 (114)
	ESP	0.01 - 0.071 (0.02 - 0.142)
	Fabric filter	0.0245 - 0.066 (0.049 - 0.132)
Dryers and grinders	Uncontrolled	8 (16)
Clinker cooler		
	Fabric filter	0.0025 - 0.03 (0.005 - 0.061)
	Gravel bed	0.011 - 0.022 (0.023 - 0.045)
	Wet scrubber	0.011 (0.022)

^a Manganese emission factors were obtained by multiplying particulate factors from References 1 and 3 by 0.05 percent (the percentage of manganese in particulate emissions). Manganese is probably present as an oxide.

5.2.2 Source Locations

Table 5-10 lists the locations of cement plants in the United States.

TABLE 5-10. LOCATION OF CEMENT PLANTS IN THE UNITED STATES^a

State(s)	Plants active (as of December 31, 1980)
New York and Maine	9
Pennsylvania, Eastern	11
Pennsylvania Western	4
Maryland and West Virginia	4
Ohio	5
Michigan	7
Indiana	5
Illinois	4
Tennessee	6
Kentucky, North Carolina, Virginia	3
South Carolina	3
Florida	6
Georgia	3
Alabama	7
Louisiana and Mississippi	4
Nebraska and Wisconsin	5
South Dakota	1
Iowa	5
Missouri	7
Kansas	5
Oklahoma and Arkansas	5
Texas	19
Wyoming, Montana, and Idaho	4
Colorado, Arizona, Utah, New Mexico	8
Washington	4
Oregon and Nevada	3
California, North	4
California, South	8
Hawaii	2
Puerto Rico	2
Total	163

^a Reference 4.

REFERENCES FOR SECTION 5.2

1. Barrett, K. W. A Review of Standards of Performance for New Stationary Sources - Portland Cement Industry. EPA-450/3-79-012, March 1979.
2. Anderson, D. Emission Factors for Trace Substances. EPA-450/2-73-001, December 1973.
3. U.S. Environmental Protection Agency. Compilation of Air Pollutant Emission Factors. AP-42, Supplement 14, May 1983.
4. U.S. Department of Interior. Minerals Yearbook. Vol. 1. Bureau of Mines. 1980.

5.3 MUNICIPAL REFUSE AND SEWAGE SLUDGE INCINERATION

Manganese emissions can result from the incineration of municipal refuse and sewage sludge. Table 5-11 shows typical manganese levels in such wastes. Concentrations of manganese in municipal sewage vary widely, depending on the sewered industrial population, the mixing of storm and sanitary sewage, and the amount of infiltration of material other than sewage sludge.¹

TABLE 5-11. MANGANESE CONCENTRATIONS IN MUNICIPAL REFUSE AND SEWAGE SLUDGES

(ppm)			
Waste type	Range	Mean	Reference
Municipal refuse	50-480	85	1
Sewage sludge	100-8800	1190	2

Municipal incineration is a process that reduces the volume of solid waste by burning. Some incinerators are best suited for incineration of a waste with particular physical characteristics. Typical municipal refuse incinerators consist of either refractory-lined or water-walled combustion chambers with a grate upon which refuse is burned.³ Figure 5-2 shows the basic configuration of a municipal refuse incinerator. The manganese-laden exhaust gases are commonly sent to a control device before being emitted to the atmosphere. Sewage sludges are typically combusted in

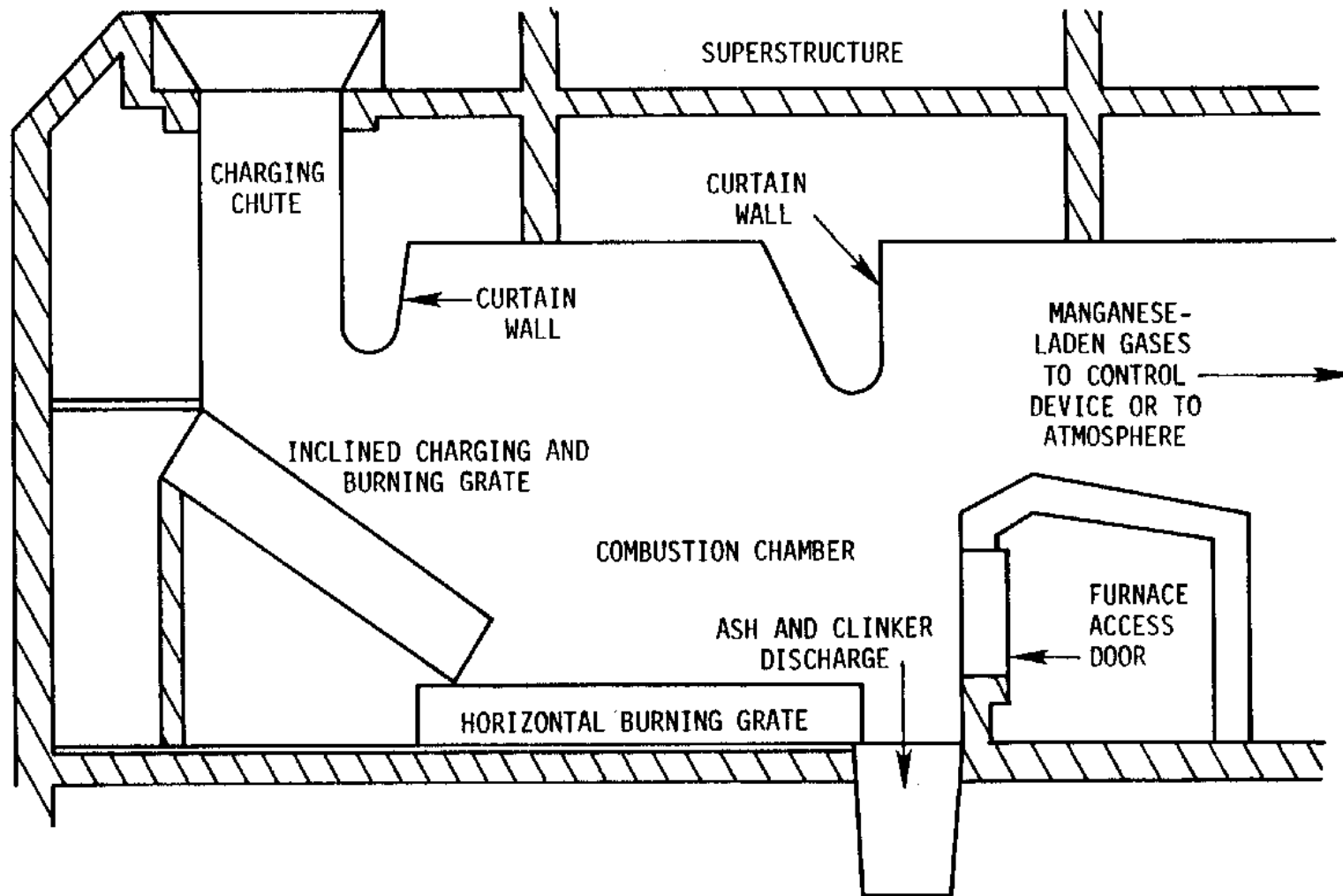

Figure 5-2. Basic configuration of a municipal refuse incinerator.²

multiple-hearth, fluidized-bed, or rotary kiln incinerators.⁴ Figure 5-3, Figure 5-4, and Figure 5-5 are schematics of a multiple-hearth, fluidized-bed, or rotary kiln incinerator system, respectively.

5.3.1 Emission Factors

Manganese emissions from municipal refuse and sewage sludge incineration are a function of 1) the manganese concentration of the refuse or sludge, 2) the amount of manganese adsorbed on the particulate or volatilized in the gas stream, and 3) the type of air pollution controls used.¹ The combustion temperature of the incinerator can influence the volatilization of the manganese species and increase emissions. Multiple-hearth and fluidized-bed incinerators operate at temperatures of 1030-1370K; rotary-kiln incinerators sometimes operate at even higher temperatures.⁴ In fluidized-bed units, the velocity of the fluidizing air, which controls the rate of elutriation, also affects atmospheric manganese emissions. Over the years, the control systems used on municipal incinerators have evolved from systems that simply reduce gas velocity in settling chambers to sophisticated electrostatic precipitators that remove up to 99 percent of all particulate matter. Wet scrubbers and (to a lesser extent) fabric filter systems are also used.

Table 5-12 presents manganese emission factors for controlled and uncontrolled municipal refuse and sewage sludge incinerators. This table shows that incinerators equipped with electrostatic precipitators or scrubbers emit only a very small fraction of the manganese typically present in the incoming waste. The emission factors for municipal refuse incinerators are based on two measurements, whereas those for the multiple-hearth and fluidized bed sewage sludge incinerators are based on four and three unit measurements, respectively. No data were available on emission factors for manganese from rotary kiln incinerators.

The city of Gallatin, Tennessee, burns municipal wastes in two 100-ton-per-day rotary combustors and uses the heat to produce steam.⁶ Measured uncontrolled manganese emissions were 0.030 kilogram per megagram of waste (0.060 pound per ton); 95 percent by weight of the manganese was found in the particles larger than 3.9 micrometers. In contrast, appreciable fractions of total arsenic, cadmium, zinc, mercury, lead, antimony, and tin were found in the <1- μ m particles.

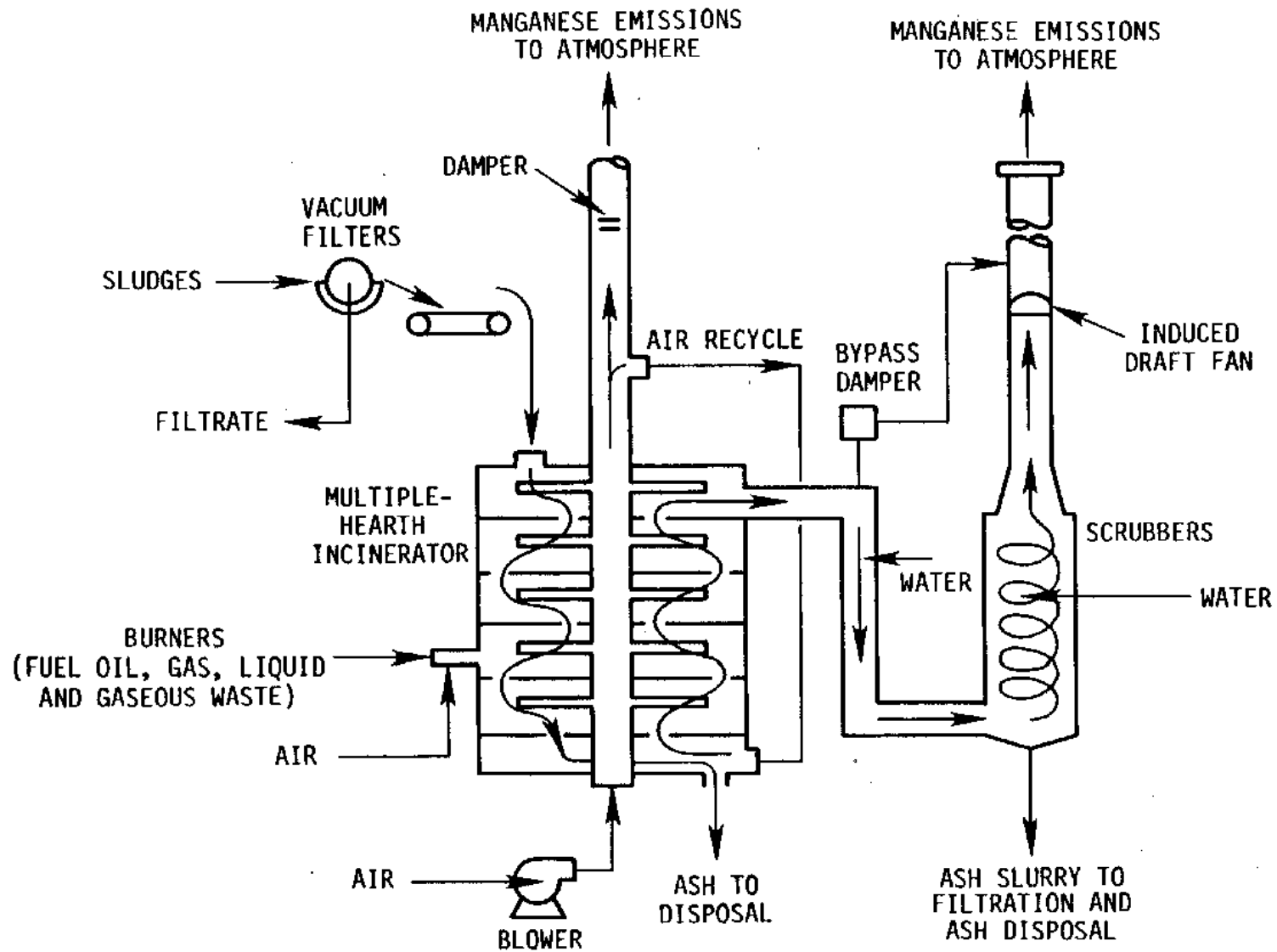

Figure 5-3. Schematic of a typical multiple-hearth incineration system.⁴

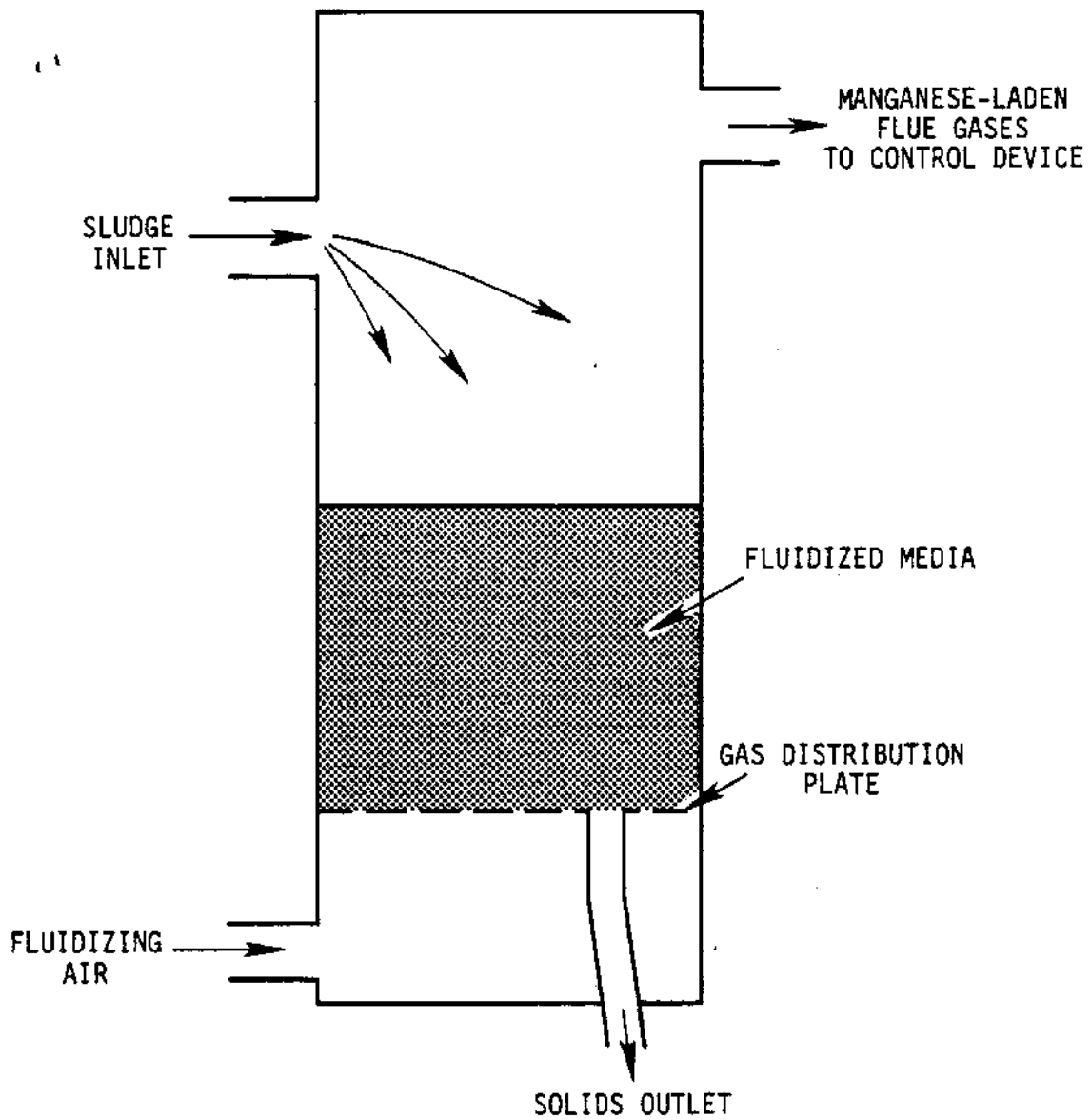

Figure 5-4. Schematic of a fluidized-bed sewage sludge incinerator.⁵

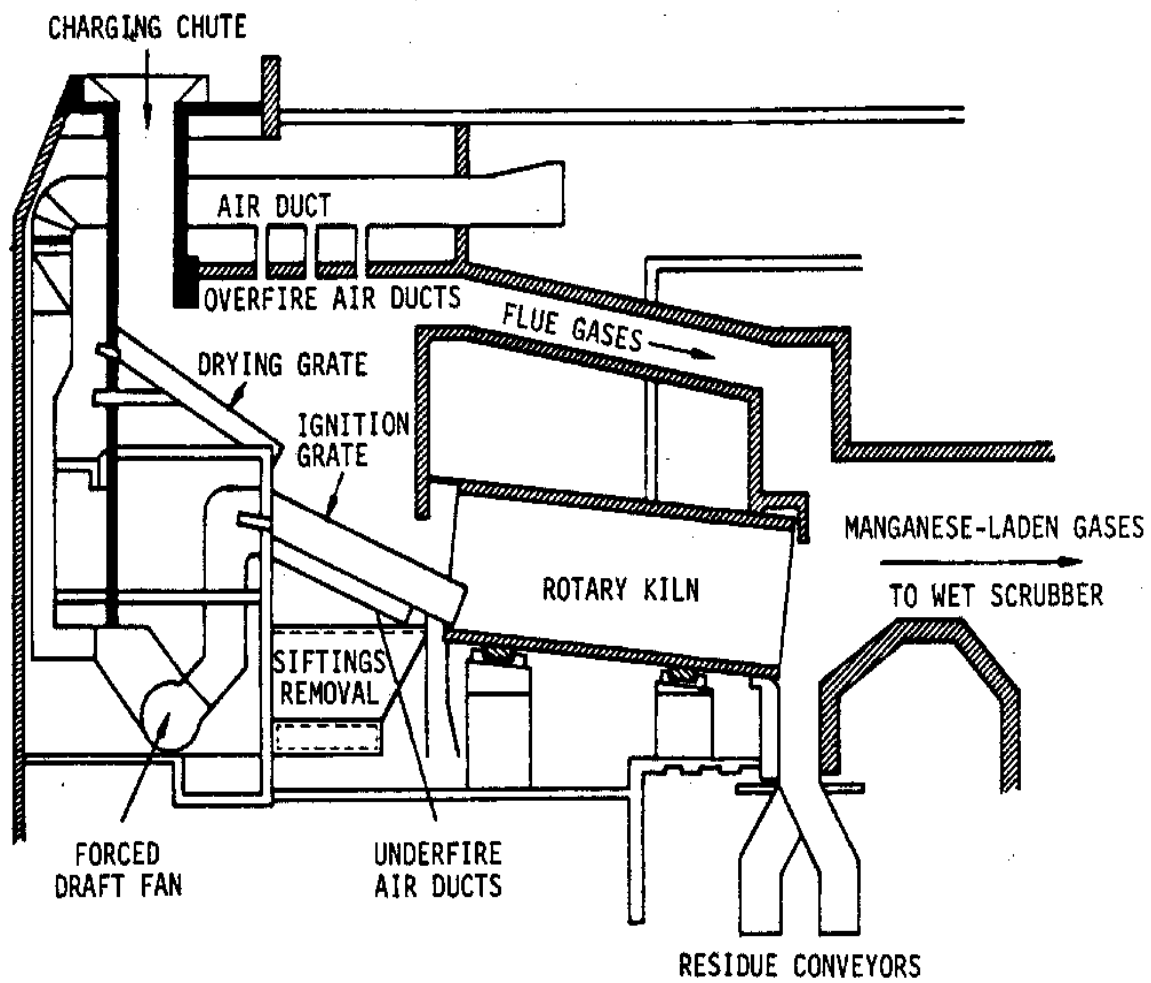

Figure 5-5. Schematic of a typical municipal rotary-kiln incineration facility.

TABLE 5-12. EMISSIONS FACTORS FOR MANGANESE FROM MUNICIPAL REFUSE AND SEWAGE SLUDGE INCINERATORS^a

Incinerator type	Control device	Manganese emission factor, kg/Mg (lb/ton) of waste incinerated
Municipal refuse	None	0.025 (0.05)
Municipal refuse	Electrostatic precipitator	0.005 (0.01)
Sewage sludge multiple-hearth	Wet scrubber	0.002 (0.004)
Sewage sludge fluidized-bed	Wet scrubber	0.0003 (0.0006)

^a References 6 and 7.

5.3.2 Source Locations

Table 5-13 presents a breakdown (by state) of the number of municipal refuse and sewage sludge incinerators in the United States. In 1978, a total of 106 municipal refuse and 358 sewage sludge incinerators were in operation nationwide. Information on the specific locations of these facilities can be found in the Compliance Data System or National Emissions Data System maintained by the U.S. Environmental Protection Agency.

REFERENCES FOR SECTION 5.3

1. Gerstle, R. W., and D. N. Albrinck, Atmospheric Emissions of Metals From Sewage Sludge Incineration. J. of Air Pollution Control Association; 32(11): 1119-1123, 1982.
2. Edwards, L. O., et al. Trace Metals and Stationary Conventional Combustion Processes. Vol. 1. EPA-600/7-80-155a, August 1980.
3. Helfand, R. M. A Review of Standards of Performance for New Stationary Sources - Incinerators. EPA-450/3-79-009, March 1979.
4. Mason, L., and S. Unger. Hazardous Material Incinerator Design Criteria. EPA-600/2-79-198, October 1979.
5. Liptak, B. G. Environmental Engineers' Handbook. Vol. III. Chilton Book Company, Radnor, Pennsylvania. 1974.
6. Cooper Engineers, Air Emission Tests of Solid Waste Combustion in a Rotary Combustor/Boiler System at Gallatin, Tennessee. Prepared for West County Agency of Contra Costa County, California. July 1984.
7. Anderson D. Emission Factors for Trace Substances. EPA-450/2-73-001, December 1973.

TABLE 5-13. POPULATION OF MUNICIPAL REFUSE AND SEWAGE SLUDGE
INCINERATORS IN THE UNITED STATES, 1978^a

State	Number of municipal refuse incinerators	Number of sewage sludge incinerators
Alabama		1
Alaska		6
Arkansas		2
California		18
Connecticut	16	11
Delaware	1	
Florida	8	3
Georgia		8
Hawaii		2
Illinois	4	6
Indiana	1	10
Iowa		4
Kansas		4
Kentucky		4
Louisiana	3	6
Maine		1
Maryland	1	7
Massachusetts		15
Michigan	3	55
Minnesota		11
Missouri	2	16
Nebraska		2
Nevada		3
New Hampshire	2	5
New Jersey	7	17
New York	31	32
North Carolina		5
Ohio	6	27
Oklahoma		2
Oregon		1
Pennsylvania	10	21
Rhode Island	1	5
South Carolina		3
Tennessee	2	9
Texas		9
Utah	2	
Virginia	2	15
Washington		5
West Virginia		3
Wisconsin	4	4
Total	106	358

^a Reference 3.

5.4 MANGANESE FUEL ADDITIVES

Manganese organometallic compounds are used as fuel additives. The most important is tricarbonylmethyl-cyclopentadienylmanganese [$\text{CH}_3\text{C}_5\text{H}_4\text{Mn}(\text{CO})_3$]. Usually known as MMT, this additive is used as an octane enhancer in leaded gasoline. Other manganese carbonyls and substituted carbonyls are used as smoke suppressants in diesel fuel, residual fuel oil, and jet fuel. Most of the additives (about 99 percent) are burned along with the fuel and the manganese is converted to the oxide, Mn_3O_4 .^{1,2} Manganese in unburned and spilled fuel is rapidly converted by sunlight to manganese oxides and carbonates.^{1,2}

Ethyl Corporation (the only producer of MMT) developed this additive in 1957; however, its use was limited because it is much more expensive than tetraethyl and tetramethyl lead. When lower lead levels in gasoline were mandated, MMT was used as a partial lead replacement. At levels of 1/8 to 1/2 gram per gallon of gasoline, MMT enhanced the octane improvement achieved by lead compounds. Subsequently, studies at General Motors^{3,4} found that MMT contributed to the plugging of catalytic converters, and studies at Ford⁵ concluded that MMT had an adverse effect on the control of hydrocarbon emissions. In another study,⁶ the investigator concluded that MMT did not have adverse effects at levels of 1/4 gram per gallon of gasoline.

An EPA statistical evaluation of all published reports⁷ led to the following conclusions, which have a confidence level of at least 98 percent:

- " MMT was strongly suspected of having an adverse effect on the oxygen sensors used in catalytic converters.

- " Some increased potential for catalyst plugging was evident with increased use of MMT.

- " MMT caused or contributed to the failure of motor vehicles to comply with hydrocarbon emission levels.

Because the case for the benefits of using MMT, such as catalyst enhancement and fuel economy, could not be established, EPA has prohibited the use of MMT in unleaded gasoline. The EPA is also requiring the phase-out of the use of MMT in leaded gasoline.⁸

5.4.1 Processing Procedures

It was not clear which of the number of procedures for making MMT described in Ethyl Corporation's patents is used in the manufacturing process. Information from published work^{9,10} make it apparent high carbon monoxide pressures (300 atmospheres typical), elevated temperatures (200°C typical), and strongly reducing conditions are common to all procedures. The following are examples:

- " Manganese chloride, methyl cyclopentadiene, carbon monoxide, and magnesium metal are reacted at 200°C and 300 atmospheres in dimethyl-formamide solution to which amines have been added. The yield is 70 percent.
- " The pyridine complex of manganese chloride, magnesium metal, methylcyclopentadiene, and carbon monoxide are reacted under heat and pressure (conditions not specified) in dimethylformamide solution and in the presence of hydrogen gas. The yield is 80 percent.
- " Manganese chloride is reacted with the molten magnesium methyl-cyclopentadiene salt and carbon monoxide under heat and pressure. The yield is 37 percent.
- " Manganese carbonyl, $MN_2(CO)_{10}$ (also a fuel additive), is prepared by reacting manganese acetate, triethyl-aluminum, and carbon monoxide under pressure in diisopropyl ether solution. The yield is 50 to 60 percent.

These reactions take place in closed reactors, and the reactor must be carefully depressurized and cooled to ambient or near-ambient temperatures to prevent the volatilization of noxious, toxic, and expensive solvents and the escape of carbon monoxide.

5.4.2 Emissions

Combustion Emissions--

A publication from Ethyl Corporation¹¹ described a mathematical model that indicated hydrocarbon emissions increased linearly with

MMT levels in fuel and that MMT enhanced catalytic converter efficiency. The finding regarding increased emissions supported EPA's position. A 1983 patent¹² indicated that hydrocarbon emissions from vehicles fueled with MMT-containing gasoline were reduced by 27 percent by the addition of 1,3 dioxolane. The patent did not indicate whether the inventor had any corporate affiliation. Such an additive, could extend the use of MMT.

Approximately 500 tons of manganese-containing fuel additives were used in 1974.¹³ Peak U.S. production was 3750 tons in the 12 months prior to MMT's ban in September 1978.¹⁴ Based on a manganese content of 24.7 percent in the MMT, and conservatively assuming that all manganese is exhausted to the atmosphere, this corresponds to annual manganese emissions of 930 tons from fuel combustion. Data are not available on the actual percentage of manganese from MMT that is exhausted. Only about 0.1 percent of MMT is emitted unburned from the tail pipe. Most of the manganese is converted to Mn_3O_4 . Current emissions due to manganese-containing fuel additives are lower and decreasing.

Evaporation--

The evaporation of MMT and other manganese carbonyls is probably not a source of significant manganese air emissions. Commercial MMT is a dark orange liquid that solidifies at $-2^{\circ}C$ ($28^{\circ}F$) and has a boiling point of $233^{\circ}C$ ($451^{\circ}F$).¹ The flash point is above $110^{\circ}C$ ($230^{\circ}F$), and the density is 1.38 grams per milliliter or 11.5 pounds per gallon.¹ Typically, gasoline is 90 percent distilled at $167^{\circ}C$ ($333^{\circ}F$), and the dry point is $209^{\circ}C$ ($408^{\circ}F$).¹⁵ Hence, MMT is appreciably less volatile than gasoline. Other manganese carbonyls have similar volatilities, Therefore, evaporative losses from fuel tanks are not a significant source of manganese emissions.

Process Losses --

The manufacture of MMT (because of its low volatility) and other manganese-containing fuel additives is not a source of significant manganese air emissions. Process yields, however, are substantially less than 100 percent, and there may be significant amounts of manganese-containing hazardous wastes that would require careful disposal to avoid ground-water contamination.

REFERENCES FOR SECTION 5.4

1. Unzelman, G. H. Manganese Gains Stature as Octane Improves for Unleaded Gasoline. *The Oil and Gas Journal*, 73(46) 49-57, 1975.
2. Ter Haar, G. L., et al. Methylcyclopentadienyl Manganese Tricarbonyl As An Anti knock. Composition and Fate of Manganese Exhaust Products. *J. Air Pollution Control Association*, 25(8) 858-60, 1975.
3. Furey, R. L., and J. C. Summers. How MMT Causes Plugging of Monolithic Converters. Available from the Society of Automotive Engineers. Report CONF-780208-46, 1978.
4. Benson, J. D. Manganese Fuel Additive (MMT) Can Cause Vehicle Problems. SAE Technical Paper 770655, 1977.
5. Holiday, E. P., and M. C. Parkinson. Another Look at the Effects of Manganese Fuel Additive (MMT) on Automotive Emissions. In: *Proceedings of Annual Meeting of Air Pollution Control Association*. 71st Volume 4, Paper No. 54.2, 1978.
6. Lenane, D. L. Effect of MMT on Emissions From Production Cars. Available from the Society of Automotive Engineers. Report CONF-780208-44, 1978.
7. Wallace, J. S., and R. J. Garbe. Effect of MMT on Exhaust Emissions. Available from Society of Automotive Engineers. Report 790707, 1979.
8. Federal Register Citations 43 FR4 1414 (September 18, 1978) and 46 Fr 58360 (December 1, 1981) relating to denial of waivers to use manganese additives as requested by Ethyl Corporation.
9. King, R. B. *Transition Metal Organometallic Chemistry*. Academic Press, New York. 1961. pp. 93-104.
10. Dub, M. *Organometallic Compounds*. Volume 1, Second Edition, First Supplement. Springer-Verlag, New York. 1963. pp. 255-257.
11. Hughmark, G. A., and B. A. Sobel. A Statistical Analysis of the Effect of MMT Concentrations on Hydrocarbon Emissions. SAE Technical Paper 800393, 1980.
12. Somorjai, G. A. Fuel Compositions and Additive Mixtures for Reducing Hydrocarbon Emissions. U.S. 4,390,345, June 28, 1983.
13. U.S. Environmental Protection Agency. Scientific and Technical Report on Manganese. EPA-600/6-74-002, April 1975.
14. U.S. Environmental Protection Agency. Health Assessment Document for Manganese. EPA 600/8-83-013F, May 1984.
15. Lane, J. C. Gasoline and Other Motor Fuels. *Kirk-Othmer Encyclopedia of Chemical Technology*, 3rd. Edition, Volume 11. John Wiley-Interscience, New York. 1981. pp. 652-694.

SECTION 6
SOURCE TEST PROCEDURES

6.1 LITERATURE REVIEW OF SAMPLING METHODS

Sampling stationary source emissions for manganese requires a procedure that provides representative samples; therefore, sampling must be done isokinetically with a sampling train that has a high efficiency for removing manganese. The EPA Method 5 source sampling train, Figure 6-1, is the basic sampling system used to obtain representative particulate emission samples from stationary sources.¹ A heated glass-fiber filter with a collection efficiency of 99.95 percent for particles 0.3 mm in diameter provides the main particulate sample collection surface. Large particles are also caught in the probe and nozzle. Particulate matter recovered from the probe, nozzle, filter, and front-half of the filter holder are defined as the particulate sample used to calculate emissions from sources subject to New Source Performance Standards. The impinger section of the Method 5 sampling train is efficient for collecting particles that penetrate the filter media and aerosols. If necessary, the impinger contents can be recovered and analyzed.

6.2 LITERATURE REVIEW OF ANALYTICAL PROCEDURES

6.2.1 Wet Chemical Method

The Periodate Method is the classic wet-chemical method of analyzing air samples for manganese.² The nature of this method is such that it can be used in almost any chemical laboratory with relatively simple equipment. If necessary, the final colorimetric estimation can be made satisfactorily with Nessler tubes. During analysis of very low concentrations, it is difficult to get and maintain complete oxidation of the manganese to permanganate. Also, the sensitivity of this method is rather poor compared with that of other methods.

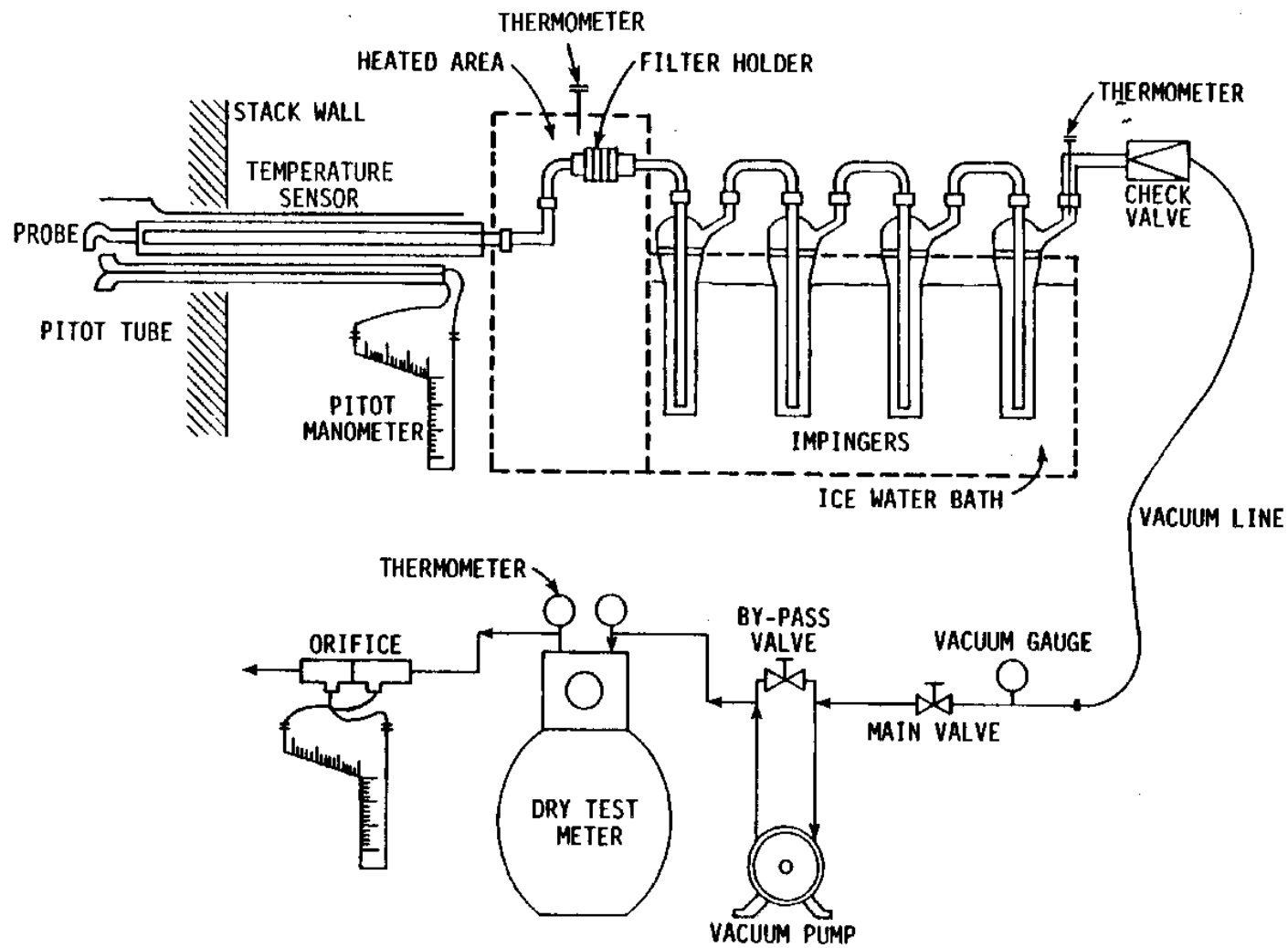

Figure 6-1. Schematic of Method 5 sampling train.

6.2.2 Spectrographic Method

The spectrographic method has been used, for some time to determine trace metals, including manganese, in air samples. Cholak and Hubbard³ described a spectrochemical method in which the manganese is isolated from interferences and concentrated in a small volume by complexing it with sodium diethyl-dithio- carbonate, and extracting it with chloroform before analysis with the spectrograph. Tabor and Warren⁴ briefly discuss a semiquantitative method suitable for estimating trace metals, including manganese, in samples collected on glass-fiber filters such as those used in air sampling. The advantages of spectroscopy are that it can be made specific (or nearly so) for almost any element, its sensitivity is adequate for most types of air samples, and it can be used for concurrent determination of a number of elements in the same sample.

6.2.3 Atomic Absorption

Salvin described the use of atomic absorption analysis for trace metals, including manganese, in the atmosphere.⁵ The advantages of this method over the others are that it is relatively simple to use and it is highly specific for a given element, Also, its sensitivity is as good or, in many cases, better than that of other methods. When glass-fiber filters are used, silica extracted from the fibers can interfere with the determination of manganese, zinc, iron, and other elements unless they are removed by the presence or addition of calcium to the solution before analysis.

6.2.4 Neutron-Activation Analysis

Neutron-activation analysis is most suitable for the analysis of very low concentrations (nanogram range) of manganese. The use of this method for air samples is described by NiFong, et al., and Dams, et al.^{6,7} The principal disadvantage of this method is that it is necessary to have access to a suitable neutron source.

REFERENCES FOR SECTION 6

1. Standards of Performance for New Stationary Sources. Federal Register, 42 (160), August 18, 1977.
2. American Conference of Governmental Industrial Hygienists. Manual of Analytical Methods Recommended for Sampling and Analysis of Atmospheric Contaminants. 1958.
3. Cholak, J., and D. M. Hubbard. Determination of Manganese in Air and Biological Material. Amer. Ind. Hyg. Assoc. 3., 21:356-360, 1960.
4. Tabor, E. C., and W. V. Warren. Distribution of Certain Metals in the Atmosphere of Some American Cities. A.M.A. Arch. Ind. Health, 17: 145-151, 1958.
5. Salvin, W. Atomic Absorption Spectroscopy. Interscience Publications, New York. 1968.
6. Nifong, G. D., E. A. Boettnee, and J. W. Winchester. Particle Size Distributions of Trace Elements in Air Pollution Aerosols. Amer. Ind. Hyg. Assoc. J.
7. Dams, R., et al. Nondestructive Neutron Activation Analysis of Air Pollution Particulates. Anal. Chem., 42:861-867, 1970.

TECHNICAL REPORT DATA
(Please read Instructions on the reverse before completing)

1. REPORT NO. EPA-450/4-85-007h	2.	3. RECIPIENT'S ACCESSION NO.
4. TITLE AND SUBTITLE Locating And Estimating Air Emissions From Sources Of Manganese	5. REPORT DATE September 1985	6. PERFORMING ORGANIZATION CODE
	8. PERFORMING ORGANIZATION REPORT NO.	
7. AUTHOR(S)	10. PROGRAM ELEMENT NO.	
9. PERFORMING ORGANIZATION NAME AND ADDRESS	11. CONTRACT/GRANT NO.	
	13. TYPE OF REPORT AND PERIOD COVERED	
12. SPONSORING AGENCY NAME AND ADDRESS Office Of Air Quality Planning And Standards (MD 14) U. S. Environmental Protection Agency Research Triangle Park, NC 27711	14. SPONSORING AGENCY CODE	
	15. SUPPLEMENTARY NOTES EPA Project Officer: Thomas F. Lahre	
16. ABSTRACT To assist groups interested in inventorying air emissions of various potentially toxic substances, EPA is preparing a series of documents such as this to compile available information on sources and emissions of these substances. This document deals specifically with manganese. Its intended audience includes Federal, State and local air pollution personnel and others interested in locating potential emitters of manganese and in making gross estimates of air emissions therefrom. This document presents information on 1) the types of sources that may emit manganese, 2) process variations and release points that may be expected within these sources, and 3) available emissions information indicating the potential for manganese release into the air from each operation.		
17. KEY WORDS AND DOCUMENT ANALYSIS		
a. DESCRIPTORS	b. IDENTIFIERS/OPEN ENDED TERMS	c. COSATI Field/Group
Manganese Emissions Sources Locating Air Emission Sources Toxic Substances		
18. DISTRIBUTION STATEMENT	19. SECURITY CLASS (This Report)	21. NO. OF PAGES 118
	20. SECURITY CLASS (This page)	22. PRICE