

United States
Environmental Protection
Agency

Office of Air Quality
Planning and Standards
Research Triangle Park, NC 27711

EPA-454/R-93-011
April 1993

Air



LOCATING AND ESTIMATING AIR EMISSIONS FROM SOURCES OF STYRENE

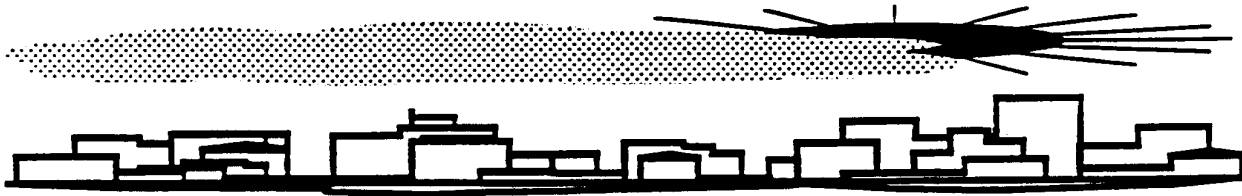

L & E

EPA-454/R-93-011
EPA Contract No. 68-D2-0160
Work Assignment No.01

LOCATING AND ESTIMATING AIR EMISSIONS
FROM SOURCES OF STYRENE

Final Report

Prepared for:

Dallas Safriet
Emission Inventory Branch
U. S. Environmental Protection Agency
Research Triangle Park, North Carolina 27711

Prepared by:

Radian Corporation
Post Office Box 13000
Research Triangle Park, North Carolina 27709

April 20, 1993

This report has been reviewed by the Office Of Air Quality Planning And Standards, U.S. Environmental Protection Agency, and has been approved for publication. Any mention of trade names or commercial products is not intended to constitute endorsement or recommendation for use.

EPA-454/R-93-011

TABLE OF CONTENTS

<u>Section</u>	<u>Page</u>
PREFACE	iii
1 Purpose of Document	1
References for Section 1	4
2 Overview of Document Contents	5
3 Background	7
Nature of Pollutant	7
Overview of Production and Use	9
References for Section 3	20
4 Emissions from Styrene Production	22
Process Description	22
Emissions	31
References for Section 4	40
5 Emissions from Major Uses of Styrene	42
Polystyrene Production	42
Styrene-Butadiene Copolymer Production	53
Styrene-Acrylonitrile Production	64
Acrylonitrile-Butadiene-Styrene Copolymer Production	72
Unsaturated Polyester Resin Production	81
Miscellaneous Styrene Copolymer Production	90
References for Section 5	93
6 Emissions from the Use of Styrene-Containing Materials	96
Thermodegradation of Styrene-Containing Materials	98
Acrylonitrile-Butadiene-Styrene Compounding	100
Unsaturated Polyester Resin Use	108

TABLE OF CONTENTS (Continued)

<u>Section</u>	<u>Page</u>
Polystyrene Foam	137
References for Section 6	148
7 Source Test Procedures	151
EPA Reference Method 18	151
NIOSH Method 1501	153
EPA Method 5040	154
Compendium Method TO-14	156
EPA Reference Method 8270	157
References for Section 7	158

LIST OF TABLES

<u>Table</u>	<u>Page</u>
1 Chemical and Physical Properties of Styrene	8
2 End-Uses of Styrene	12
3 Potential Source Categories of Styrene Emissions	13
4 Styrene Production Locations and Capacities	23
5 Styrene Storage and Secondary Emission Factors	33
6 Average Emission Factors for Fugitive Emissions	35
7 Control Techniques and Efficiencies Applicable to Equipment Leak Emissions	37
8 Polystyrene Production Facilities	44
9 Emission Factors for Polystyrene Production	54
10 Styrene-Butadiene Elastomer Production Facilities	56
11 Styrene-Butadiene Latex Production Facilities	57
12 Typical Recipe for Emulsion SBR	60
13 Emission Factors for Styrene-Butadiene Production	65
14 Styrene-Acrylonitrile Production Facilities	66
15 Acrylonitrile-Butadiene-Styrene Production Facilities	74
16 Typical Components Used to Form Unsaturated Polyester Resins	82
17 Producers of Unsaturated Polyester Resins	85
18 Emission Factors for Styrene from UPR Production	89
19 Miscellaneous Uses for Styrene in Chemical Production	91
20 Prevalence of Styrenic Resin Fabricators	97
21 Styrene Emitted from Thermooxidative Degradation	99
22 Summary of Source Testing Data for an ABS Compounding Facility Uncontrolled and with Temporary Controls	104
23 Summary of ABS Compounding Facility Source Test Data After Installation of Permanent Controls	107
24 Styrene Emission Factors for Cultured Marble and Sink Manufacturing Operations	119

LIST OF TABLES (Continued)

<u>Table</u>		<u>Page</u>
25	Geographic Distribution of the Fiberglass Boat Industry by Number of Facilities	127
26	VOC Emission Factors for Polyester Resin Product Fabrication Processes	131
27	Monomer-Based Emission Factors for Polyester Resin/Fiberglass Operations	132
28	Factors Affecting Styrene Emissions from Lamination . .	135
29	Domestic Consumption of Polystyrene Foam by End Uses . .	138
30	Distribution of PSF Producers by State	139

LIST OF FIGURES

<u>Figure</u>	<u>Page</u>
1 Chemical Use Tree for Styrene	11
2 Locations of Plants Manufacturing Styrene	24
3 Process Flow Diagram for Styrene Production by Ethylbenzene Dehydrogenation	26
4 Process Flow Diagram for Styrene Production by Ethylbenzene Hydroperoxidation	28
5 Process Flow Diagram for Styrene Production by Isothermal Processing	30
6 Polystyrene Production by Suspension Polymerization	48
7 Polystyrene Production by Mass Polymerization	49
8 Polystyrene Production by Solution Polymerization	51
9 S-B/SBR Production by Emulsion Polymerization	58
10 SBR Production by Solution Polymerization	62
11 Production of SAN by Emulsion Polymerization	68
12 Production of SAN by Suspension Polymerization	70
13 Production of SAN by Continuous Mass Polymerization	71
14 Production of ABS/SAN by Emulsion Polymerization	76
15 Production of ABS by Suspension Polymerization	78
16 Production of ABS by Continuous Mass Polymerization	80
17 Typical Reactions for Unsaturated Polyester and Polyester Resin Formation	84
18 Unsaturated Polyester Resin Production	88
19 Original Vacuum and Vent System at an ABS Compounding Facility	101
20 Permanent VOC Controls at an ABS Compounding Facility	106
21 Typical Filament Winding Process	112
22 Typical Continuous Lamination Production Process	114
23 Small, Custom Operation Production Area	117
24 Large Operation Production Area	121
25 Geographic Distribution of Fiberglass Boat Manufacturing Facilities for States with More than Ten Facilities	128

LIST OF FIGURES (Continued)

<u>Figure</u>		<u>Page</u>
26	Fiberglass Boat Production Process	129
27	Flow Diagram of Typical Polystyrene Foam Sheet Manufacturing Process	141
28	Flow Diagram of a Typical Polystyrene Foam Board Manufacturing Process	143
29	Flow Diagram of a Typical EPS Bead Process	145
30	Integrated Bag Sampling Train	152
31	Schematic Diagram of Trap Desorption/Analysis System . .	155

SECTION 1
PURPOSE OF DOCUMENT

The Environmental Protection Agency (EPA) and State and local air pollution control agencies are becoming increasingly aware of the presence of substances in the ambient air that may be toxic at certain concentrations. This awareness, in turn, has led to attempts to identify source/receptor relationships for these substances and to develop control programs to regulate emissions. Unfortunately, very little information is available on the ambient air concentrations of these substances or on the sources that may be discharging them to the atmosphere.

To assist groups interested in inventorying air emissions of various potentially toxic substances, EPA is preparing a series of documents such as this that compiles available information on sources and emissions of these substances. Prior documents in the series are listed below:

<u>Substance</u>	<u>EPA Publication Number</u>
Acrylonitrile	EPA-450/4-84-007a
Carbon Tetrachloride	EPA-450/4-84-007b
Chloroform	EPA-450/4-84-007c
Ethylene Dichloride	EPA-450/4-84-007d
Formaldehyde (Revised)	EPA-450/2-91-012
Nickel	EPA-450/4-84-007f
Chromium	EPA-450/4-84-007g
Manganese	EPA-450/4-84-007h
Phosgene	EPA-450/4-84-007i
Epichlorohydrin	EPA-450/4-84-007j
Vinyl Chloride	EPA-450/4-84-007k
Ethylene Oxide	EPA-450/4-84-007l
Chlorobenzenes	EPA-450/4-84-007m
Polychlorinated Biphenyls (PCBs)	EPA-450/4-84-007n
Polycyclic Organic Matter (POM)	EPA-450/4-84-007p
Benzene	EPA-450/4-84-007q
Organic Liquid Storage Tanks	EPA-450/4-88-004
Coal and Oil Combustion Sources	EPA-450/2-89-001
Municipal Waste Combustors	EPA-450/2-89-006
Perchloroethylene and Trichloroethylene	EPA-450/2-90-013

1,3-Butadiene	EPA-450/2-89-021
Chromium (supplement)	EPA-450/2-89-002
Sewage Sludge	EPA-450/2-90-009

This document deals specifically with styrene. Its intended audience includes Federal, State and local air pollution personnel and others who are interested in locating potential emitters of styrene, and making gross estimates of air emissions therefrom.

Because of the limited amounts of data available on some potential sources of styrene emissions, and since the configurations of many sources will not be the same as those described here, this document is best used as a primer to inform air pollution personnel about (1) the types of sources that may emit styrene, (2) process variations and release points that may be expected within these sources, and (3) available emissions information indicating the potential for styrene to be released into the air from each operation.

The reader is strongly cautioned against using the emissions information contained in this document to try to develop an exact assessment of emissions from any particular facility. Because insufficient data are available to develop statistical estimates of the accuracy of these emission factors, no estimate can be made of the error that could result when these factors are used to calculate emissions from any given facility. It is possible, in some extreme cases, that order-of-magnitude differences could result between actual and calculated emissions, depending on differences in source configurations, control equipment, and operating practices. Thus, in situations where an accurate assessment of styrene emissions is necessary, source-specific information should be obtained to confirm the existence of particular emitting operations, the types and effectiveness of control measures, and the impact of operating practices. A source test and/or material balance should be considered as the best means to determine air emissions directly from an operation.

In addition to the information presented in this document, another potential source of emissions data for styrene is the

Toxic Chemical Release Inventory (TRI) form required by Section 313 of Title III of the Superfund Amendments and Reauthorization Act of 1986 (SARA 313).¹ SARA 313 requires owners and operators of certain facilities that manufacture, import, process or otherwise use certain toxic chemicals to report annually their releases of these chemicals to any environmental media. As part of SARA 313, EPA provides public access to the annual emissions data. The TRI data include general facility information, chemical information, and emissions data. Air emissions data are reported as total facility release estimates, broken out into fugitive and point components. No individual process or stack data are provided to EPA. The TRI requires the use of available stack monitoring or measurement of emissions to comply with SARA 313. If monitoring data are unavailable, emissions are to be quantified based on best estimates of releases to the environment.

The reader is cautioned that the TRI will not likely provide facility, emissions, and chemical release data sufficient for conducting detailed exposure modeling and risk assessment. In many cases, the TRI data are based on annual estimates of emissions (i.e., on emission factors, material balances, engineering judgment). The reader is urged to obtain TRI data in addition to information provided in this document to locate potential emitters of styrene, and to make preliminary estimates of air emissions from these facilities. To obtain an exact assessment of air emissions from processes at a specific facility, source tests or detailed material balance calculations should be conducted, and detailed plant site information should be compiled.

REFERENCES FOR SECTION 1

1. Toxic Chemical Release Reporting: Community Right-To-Know. Federal Register 52(107): 21152-21208. June 4, 1987.

SECTION 2 OVERVIEW OF DOCUMENT CONTENTS

As noted in Section 1, the purpose of this document is to assist Federal, State and local air pollution agencies and others who are interested in locating potential air emitters of styrene and making gross estimates of air emissions therefrom. Because of the limited background data available, the information summarized in this document does not and should not be assumed to represent the source configuration or emissions associated with any particular facility.

This section provides an overview of the contents of this document. It briefly outlines the nature, extent, and format of the material presented in the remaining sections of this report.

Section 3 of this document briefly summarizes the physical and chemical characteristics of styrene, and provides an overview of its production and use. This background section may be useful to someone who needs to develop a general perspective on the nature of this substance and how it is manufactured and consumed.

Sections 4, 5, and 6 of this document focus on major source categories that may discharge styrene air emissions. Section 4 discusses emissions from the production of styrene; Section 5 discusses emissions from the major uses of styrene; and Section 6 addresses emissions from the use of styrene-containing materials.

For each major industrial source category described in Sections 4, 5, and 6, example process descriptions and flow diagrams are given, potential emission points are identified, and available emission factor estimates are presented that show the potential for styrene emissions before and after controls are employed by industry. Individual companies are named that are reported to be involved with either the production or use of styrene based primarily on information from trade publications.

The final section of this document summarizes available procedures for source sampling and analysis of styrene. Details are not prescribed nor is any EPA endorsement given or implied to

any of these sampling and analysis procedures. At this time, EPA has not generally evaluated these methods. Consequently, this document merely provides an overview of applicable source sampling procedures, citing references for those interested in conducting source tests.

This document does not contain any discussion of health or other environmental effects of styrene, nor does it include any discussion of ambient air levels or ambient air monitoring techniques.

Comments on the contents or usefulness of this document are welcomed, as is any information on process descriptions, operating practices, control measures and emissions information that would enable EPA to improve its contents. All comments should be sent to:

Chief, Emission Factor and Methodologies Section
Emission Inventory Branch (MD-14)
U. S. Environmental Protection Agency
Research Triangle Park, North Carolina 27711

SECTION 3
BACKGROUND

NATURE OF POLLUTANT

Styrene (CAS No. 100-42-5) is an unsaturated aromatic monomer that is widely used in the production of plastics, resins, and elastomers. In the past century production and use of styrene have increased rapidly because it can be polymerized and copolymerized easily to produce a wide variety of products. Styrene was the twenty-first highest-volume chemical produced in the United States in 1988.¹

Styrene's molecular formula is represented as:

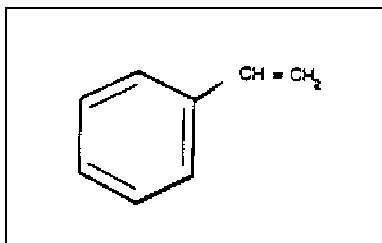

Table 1 shows the chemical and physical properties of styrene. Because of styrene's flammability and its ease of polymerization, an inhibitor (10-15 ppm tert-butylcatechol) must be added during storage and high temperatures must be avoided.²

Styrene is released to the atmosphere during its manufacture and from the use of styrene-containing materials. Styrene has also been detected in small amounts in automobile emissions³ and from publicly owned treatment works.⁴ The combustion of styrene-based products is another potential source of styrene emissions.⁵

Styrene is very reactive in the air, reacting readily with hydroxyl radicals and ozone.⁶ Styrene readily undergoes oxidation by ozone to produce formaldehyde, benzaldehyde, benzoic acid, and traces of formic acid. The styrene half-life resulting from its oxidation by ozone is estimated to be at least 9 hours.⁶ The oxidation of hydroxyl radicals yields benzaldehyde. The estimated half-life of styrene from this oxidation is 3 hours.⁶

TABLE 1. CHEMICAL AND PHYSICAL PROPERTIES OF STYRENE

Synonyms:	Cinnamene, cinnamenol, cinnamol, ethenylbenzene, monotryrene, phenethylene, phenlethene, phylethylene, styrole, styrolene, styron, styropol, styropor, vinylbenzene, vinylbenzol			
Chemical Abstracts Registry Number:	100-42-5			
Molecular Formula:	$C_6H_5CH=CH_2$			
Molecular Weight:	104.16			
Ambient State:	Colorless volatile liquid			
Boiling Point: (760 mm Hg)	145.2°C (293.4°F)			
Freezing Point:	-30.6°C (-23.1°F)			
Density:	0.9018 g/cm ³ (25°C)			
Solubility:	Soluble in ethyl ether, benzene, methanol, toluene, ethanol, acetone, n-heptane, carbon tetrachloride, carbon disulfide; slightly soluble in water (about 25 mg/100 g water at 25°C)			
Flammable (explosive) Limits:	1.1-6.1% by volume in air			
Flashpoint:	34.4°C (94°F) Tag closed cup 36.7°C (98°F) Tag open cup			
Autoignition Temperature:	490°C (914°F)			
Vapor Pressure:	°F	(°C)	mm Hg	(kPa)
	50	(10)	2.34	(0.31)
	68	(20)	4.50	(0.60)
	77	(25)	6.45	(0.86)
	86	(30)	8.21	(1.09)
	104	(40)	14.30	(1.91)
Concentration in Saturated Air:	8,500 ppm (25°C)			
Odor Threshold:	0.05 - 0.15 ppm			
Conversion Factors: (25°C, 760 mm Hg)	1 ppm = 4.26 mg/m ³ 1 mg/m ³ = 0.235 ppm			

Source: References 7 and 8.

Styrene released to water is expected to have an evaporative half-life of 23.8 hours, assuming a water depth of 1 meter (3.28 feet). In addition, styrene may be oxidized by some common water treatment compounds. Epichlorohydrin is formed in the presence of styrene and aqueous chlorine (hypochlorous acid).³

Liquid styrene exposed to air results in polymerization of styrene initiated by ozone. As it polymerizes, styrene becomes increasingly viscous until a clear, glossy solid is formed.⁹

OVERVIEW OF PRODUCTION AND USE

The total annual capacity of styrene manufacturing facilities in the United States was 4,075,142 Mg (8984 MM lbs) in 1989.¹⁰ The majority of styrene is produced by dehydrogenation of ethylbenzene, with about 15 percent produced by hydroperoxidation of ethylbenzene. Propylene is a coproduct in the hydroperoxidation process. In 1989, eight companies at nine locations produced styrene in the United States. One additional facility has been on standby since 1985.¹⁰ The ethylbenzene used to manufacture styrene is produced by alkylation of benzene or extraction from mixed xylenes.¹¹ Most ethylbenzene production processes are for captive styrene uses rather than for sale of the monomer.¹⁰

Styrene is manufactured as an intermediate for the production of polystyrene (68%), styrene-butadiene (SBR) elastomers (6%), latexes (SBR latexes containing <45% styrene and styrene-butadiene latexes containing >45% styrene) (7%), acrylonitrile-butadiene styrene (ABS) resins and styrene-acrylonitrile (SAN) (9%), unsaturated polyester resins (7%), and for miscellaneous products and export (3%).¹² Seven of the eight styrene production facilities have some captive consumption of styrene monomer. Captively consumed monomer is mainly used for manufacturing polystyrene, but it is also used to a lesser extent to produce ABS, SAN, and styrene-butadiene copolymer latexes.¹²

Figure 1 and Table 2 show some of the end products from styrene. These products and some of their production processes will be covered in detail in Sections 5 and 6. Table 3 lists the potential source categories of styrene emissions by Standard Industrial Classification (SIC) code. It is important to note that these source categories do not necessarily denote significant sources of styrene emissions.

Production Method	Use	Percent
Ethylbenzene Dehydrogenation (85%)	Polystyrene	68
	Styrene butadiene (SBR) elastomer	6
	Styrene butadiene (SBR) latex (contains <45% styrene) and styrene-butadiene latex (contains >45% styrene)	7
Ethylbenzene Hydroperoxidation (15%)	Unsaturated polyester resins	7
	Acrylonitrile-butadiene-styrene resins and styrene-acrylonitrile	9
	Miscellaneous and export	3
		100

Figure 1. Chemical Use Tree for Styrene¹²

3003814R

Table 2

TABLE 2. END USES OF STYRENE

Polystyrene	Insulation board, loose-fill packaging, disposable dinnerware, food containers, toys, games, hobby kits, housings for room air conditioners and small handheld appliances, television cabinets, shower doors, drain pipes, tubing, light diffusers, audio and video tape cassettes, combs, brushes, eyeglasses, picnic coolers, molded shutters, furniture parts, watering cans, soap dishes, room dividers
Styrene butadiene rubber (SBR) elastomers and latexes	Passenger car tires, industrial hoses, conveyer belts, appliance parts, wire and cable insulation, footwear, coated fabrics, car bumpers and weatherstrips, additive in cements and adhesives
Styrene-butadiene (S-B) latexes	Tufted carpet and upholstery backcoatings, binder for paper coatings, binder for felt base of vinyl floor tile, cement additive, component of latex paints
Acrylonitrile-butadiene-styrene (ABS)	Piping (drain, waste, and vent), conduit, pipefittings, automotive components (instrument panels, consoles, front radiator grilles, headlight housings, etc.), refrigerator doorliners and food compartments, telephones, luggage and cases, toys, hobby kits, shower stalls and bathroom fixtures for mobile homes, margarine rubs, radio chassis
Styrene-acrylonitrile (SAN)	Drinking tumblers, blender jars and covers, dishes, instrument panel lenses, battery cases
Unsaturated polyester resins(reinforced plastics/composites)	Fiberglass reinforced boats, storage tanks, tub, spa, and shower units, truck camper tops, recreational vehicles, wall panels, cultured marble products, automotive parts, appliance/electrical components, and many other products.

Source: Reference 8.

TABLE 3. POTENTIAL SOURCE CATEGORIES OF STYRENE EMISSIONS

SIC CODE ^a	SOURCE DESCRIPTION
1331	Crude petroleum and natural gas
1321	Natural gas liquids
1711	Plumbing, heating, air-conditioning
1743	Terrazzo, tile, marble, mosaic work
2221	Broadwoven fabric mills, manmade
2262	Finishing plants, manmade
2295	Coated fabrics, not rubberized
2431	Millwork
2434	Wood kitchen cabinets
2492	Reconstituted wood products
2499	Wood products, not elsewhere classified
2511	Wood household furniture
2517	Wood TV and radio cabinets
2519	Household furniture not elsewhere classified
2522	Office furniture, except wood
2531	Public building and related furniture
2599	Furniture and fixtures, not elsewhere classified
265	PAPER AND ALLIED PRODUCTS
2621	Paper mills
2631	Paperboard mills
265	Paperboard containers and boxes
2655	Fiber cans, drums, and similar products
2657	Folding paperboard boxes
267	Miscellaneous converted paper products
2672	Paper, coated and laminated, not elsewhere classified
28	CHEMICALS AND ALLIED PRODUCTS
281	Industrial gases
2812	Inorganic pigments
2813	Industrial inorganic chemicals, not elsewhere classified

TABLE 3. (Continued)

2816	Industrial pigments
2819	Industrial inorganic chemicals, not elsewhere classified
282	Plastics materials and synthetics
2821	Plastics materials and resins
2823	Cellulosic manmade fibers
2833	Medicinals and botanicals
2834	Pharmaceutical preparations
2835	Diagnostic substances
2836	Biological products (excluding diagnostic)
2841	Soap and other detergents
2842	Polishes and sanitation goods
2843	Surface active agents
2844	Toilet preparations
2851	Paints and allied products
286	Industrial organic chemicals
2861	Gum and wood chemicals
2865	Cyclic crudes and intermediates
2869	Industrial organic chemicals, not elsewhere classified
2873	Nitrogenous fertilizers
2874	Phosphatic fertilizers
2879	Agricultural chemicals, not elsewhere classified
2891	Adhesive and sealants
2892	Explosives
2899	Chemical preparations, not elsewhere classified
29	PETROLEUM AND COAL PRODUCTS
2911	Petroleum refining
2951	Asphalt paving mixtures and blocks
2992	Lubricating oils and greases
2999	Petroleum and coal products, not elsewhere classified

TABLE 3. (Continued)

30	RUBBER AND MISCELLANEOUS PLASTICS PRODUCTS
3011	Tires and inner tubes
3021	Rubber and plastics footwear
3052	Rubber and plastics hose and belting
3069	Fabricated rubber products, not elsewhere classified
308	Miscellaneous plastics products, not elsewhere classified
3081	Unsupported plastics film and sheet
3082	Unsupported plastics profile shapes
3083	Laminated plastics plate and sheet
3084	Plastics pipe
3086	Plastics foam products
3087	Custom compound purchased resins
3088	Plastic plumbing fixtures
3089	Plastics products, not elsewhere classified
3142	House slippers
3229	Pressed and blown glass, not elsewhere classified
3241	Cement, hydraulic
3261	Vitreous plumbing fixtures
3271	Concrete block and brick
3272	Concrete products, not elsewhere classified
3274	Lime
3281	Cut stone and stone products
3291	Abrasive products
329	Mineral wool
3299	Non-metallic mineral products, not elsewhere classified
3312	Blast furnaces and steel mills
3313	Electrometallurgical products
316	Cold finishing of steel shapes
3321	Gray and ductile iron foundries
3324	Steel investment foundries

TABLE 3. (Continued)

3325	Steel foundries, not elsewhere classified
3339	Primary nonferrous metals, not elsewhere classified
3341	Secondary nonferrous metals
3363	Aluminum die-casting
3364	Nonferrous die-casting, excluding aluminum
3365	Aluminum foundries
3366	Copper foundries
3369	Nonferrous foundries, not elsewhere classified
34	FABRICATED METAL PRODUCTS
3423	Hand and edge tools, not elsewhere classified
343	Plumbing and heating, except electric
3431	Metal sanitary ware
344	Fabricated structural metal products
3441	Fabricated structural metal
3442	Metal doors, sash, and trim
3343	Fabricated plate work (boiler shops)
3444	Sheet metal work
3446	Architectural metal work
3451	Screw machine products
3479	Metal coating and allied services
3498	Fabricated pipe and fittings
3499	Fabricated metal products, not elsewhere classified
3511	Turbines and turbine generator sets
3519	Internal combustion engines, not elsewhere classified
352	Farm and garden machinery
3523	Farm machinery and equipment
3533	Oil and gas field machinery
3541	Machine tools, metal cutting types
3546	Power-driven handtools

TABLE 3. (Continued)

3548	Welding apparatus
3561	Pumps and pumping equipment
3563	Air and gas compressors
3564	Blowers and fans
3575	Computer terminals
3585	Refrigeration and heating equipment
3599	Industrial machinery, not elsewhere classified
3612	Transformers, except electronic
3613	Switchgear and switchboard apparatus
3621	Motors and generators
3624	Carbon and graphite products
3625	Relays and industrial controls
3643	Current-carrying wiring devices
3644	Noncurrent-carrying wiring devices
3647	Vehicular lighting equipment
3661	Telephone and telegraph apparatus
3663	Radio and TV communications equipment
367	Electric components and accessories
3671	Electron tubes
3674	Semiconductors and related devices
3679	Electronic components, not elsewhere classified
3694	Engine electrical equipment
37	TRANSPORTATION EQUIPMENT
371	Motor vehicles and equipment
3711	Motor vehicles and car bodies
3713	Truck and bus bodies
3714	Motor vehicles parts and accessories
3715	Truck trailers
3716	Motor homes

TABLE 3. (Continued)

3721	Aircraft
373	Ship and boat building and repairing
3731	Ship building and repairing
3732	Boat building and repairing
3792	Travel trailers and campers
3799	Transportation equipment, not elsewhere classified
3812	Search and navigation equipment
3821	Laboratory apparatus and furniture
3826	Analytical instruments
3829	Measuring and controlling devices, not elsewhere classified
3842	Surgical appliances and supplies
3844	X-ray apparatus and tubes
3861	Photographic equipment and supplies
39	MISCELLANEOUS MANUFACTURING INDUSTRIES
3931	Musical instruments
394	Toys and sporting goods
3944	Games, toys, and children's vehicles
3949	Sporting and athletic goods, not elsewhere classified
3965	Fasteners, buttons, needles, and pins
3999	Manufacturing industries, not elsewhere classified
4225	General warehousing and storage
4226	Special warehousing and storage, not elsewhere classified
4231	Trucking terminal facilities
4991	Marine cargo handling
4612	Crude petroleum pipelines
4953	Refuse systems
4961	Steam and air-conditioning supply
5091	Sporting and recreational goods

TABLE 3. (Continued)

516	Chemicals and allied products
5171	Petroleum bulk stations and terminals
6512	Nonresidential building operators
6514	Dwelling operators, excluding apartments
7389	Business services, not elsewhere classified
7999	Amusement and recreation, not elsewhere classified
8062	General medial and surgical hospitals
8731	Commercial physical research
8999	Services, not elsewhere classified

^aSIC Code is listed as a potential source in the EPA "Crosswalk" document.¹³ The data in Crosswalk were obtained primarily from permitting and source test information contained in the 1986 National Air Toxics Information Clearinghouse (NATICH) data base. Additional data were gathered from the Organic Chemical Producers' Data Base and Air Emissions Species Data Manual (Volume I, Volatile Organic Compound Species profiles), and SARA 313 Toxic Release Inventory.¹³

REFERENCES FOR SECTION 3

1. Chemical and Engineering News. Facts and Figures for the Chemical Industry at a Glance. pp. 36-45. June 1989.
2. National Research Council. The Alkyl Benzenes. Committee on Alkyl Benzene Derivatives; Board on Toxicology and Environmental Health Hazards; Assembly of Life Science. National Academy Press. 1981.
3. Santodonato, J., et al. Investigation of Selected Potential Environmental Contaminants: Styrene, Ethylbenzene, and Related Compounds. EPA-560/11-80-018. U. S. Environmental Protection Agency, Washington, D.C. 1980.
4. Pope, A. A., et al. Toxic Air Pollutant Emission Factors - A Compilation for Selected Air Toxic Compounds and Sources. EPA-450/2-88-006. U. S. Environmental Protection Agency, Research Triangle Park, North Carolina. 1988.
5. Pfaffli, P., et al. Thermal Degradation Products of Homopolymer Polystyrene in Air. Scand. J. Work Environ. and Health. Suppl. 2:22-27. 1978.
6. Alexander, M. The Environmental Fate of Styrene. The SIRC Review. pp. 33-42. April 1990.
7. Kirk-Othmer Encyclopedia of Chemical Technology. 3rd ed. Styrene. Volume 21. John Wiley and Sons. New York, New York. pp. 770-801. 1983.
8. U. S. Department of Health and Human Services. Criteria for a Recommended Standard. Occupational Exposure to Styrene. DHHS (NIOSH) Publication No. 83-119. National Institute for Occupational Safety and Health, Cincinnati, Ohio. 1983.
9. Lowenheim, F. A. and M. K. Moran. Styrene. In: Faith, Keyes, and Clark's Industrial Chemicals. John Wiley and Sons. New York, New York. pp. 779-785. 1975.
10. SRI International. 1989 Directory of Chemical Producers, United States of America. Menlo Park, California. 1989.
11. U. S. Environmental Protection Agency. Benzene Emissions from the Ethylbenzene/Styrene Industry - Background Information for Proposed Standards. EPA-450/3-70-035a. Research Triangle Park, North Carolina. 1980.
12. A. T. Kearney. Impact Analysis of the EPA Office of Drinking Water Proposal to Regulate Styrene. Styrene Information Research Center. 1989.

13. Pope, A. A., et al. Toxic Air Pollutant/Source Crosswalk - A Screening Tool for Locating Possible Sources Emitting Toxic Air Pollutants, Second Edition. EPA-450/2-89-017. U. S. Environmental Protection Agency, Research Triangle Park, North Carolina. 1989.

SECTION 4

EMISSIONS FROM STYRENE PRODUCTION

Styrene production and the associated air emissions are described in this section. Process flow diagrams are included as appropriate, with specific streams or vents in the figures labeled to correspond with the discussion in the text. Emission factors for the production processes are presented when available, and control technologies are described. The reader should contact the specific facility to verify the nature of the process used, production volume, and controls in place before applying any of the emission factors presented.

Styrene is currently produced by eight companies at nine locations in the United States. One additional facility has been on standby since 1985 and is not currently manufacturing styrene. The production locations and capacities are presented in Table 4. The total annual capacity for all styrene manufacturing facilities is 4,075,142 Mg (8984 MM lbs) (not including the plant on standby),¹ with facilities operating at 98 percent of capacity.² As shown in Figure 2, the majority of styrene-manufacturing facilities are located on the Gulf Coast.

All but one plant manufactures styrene by dehydrogenation of ethylbenzene. The other facility uses hydroperoxidation of ethylbenzene to produce propylene, with styrene as a by-product.

PROCESS DESCRIPTION

Ethylbenzene Dehydrogenation

The majority of styrene produced in the United States is produced by the dehydrogenation of ethylbenzene. Seven facilities have the capacity to produce an annual total of 3,480,926 Mg (7674 MM lbs).

TABLE 4. STYRENE PRODUCTION LOCATIONS AND CAPACITIES

Facility	Location	Annual Capacity	
		Mg/yr	MM lb/yr
Amoco Corporation	Texas City, TX	362,880	800
ARCO Chemical Co.	Channelview, TX ^a	594,216	1310
	Monaca, PA	99,792	220
Chevron Corporation	St. James, LA	272,160	600
Cos-Mar, Inc.	Carville, LA	680,400	1500
Dow chemical	Freeport, TX	639,576	1410
	Midland, MI ^b	146,966	324
Huntsman Chemical Corp.	Bayport, TX	453,600	1000
Rexene Products Co.	Odessa, TX	145,152	320
Sterling Chemicals, Inc.	Texas City, TX	680,400	1500
		4,075,142	8984

^aEthylbenzene hydroperoxidation process.

^bPlant has been on standby since 1985 (not included in total capacity).

NOTE: This listing is subject to change as market conditions change, facility ownership changes, plants are closed down, etc. The reader should verify the existence of particular facilities by consulting current listings and/or the plants themselves. The level of styrene emissions from any given facility is a function of variables such as capacity, throughput, and control measures, and should be determined through direct contacts with plant personnel. These operating plants and locations were current as of January 1990.

Source: Reference 1

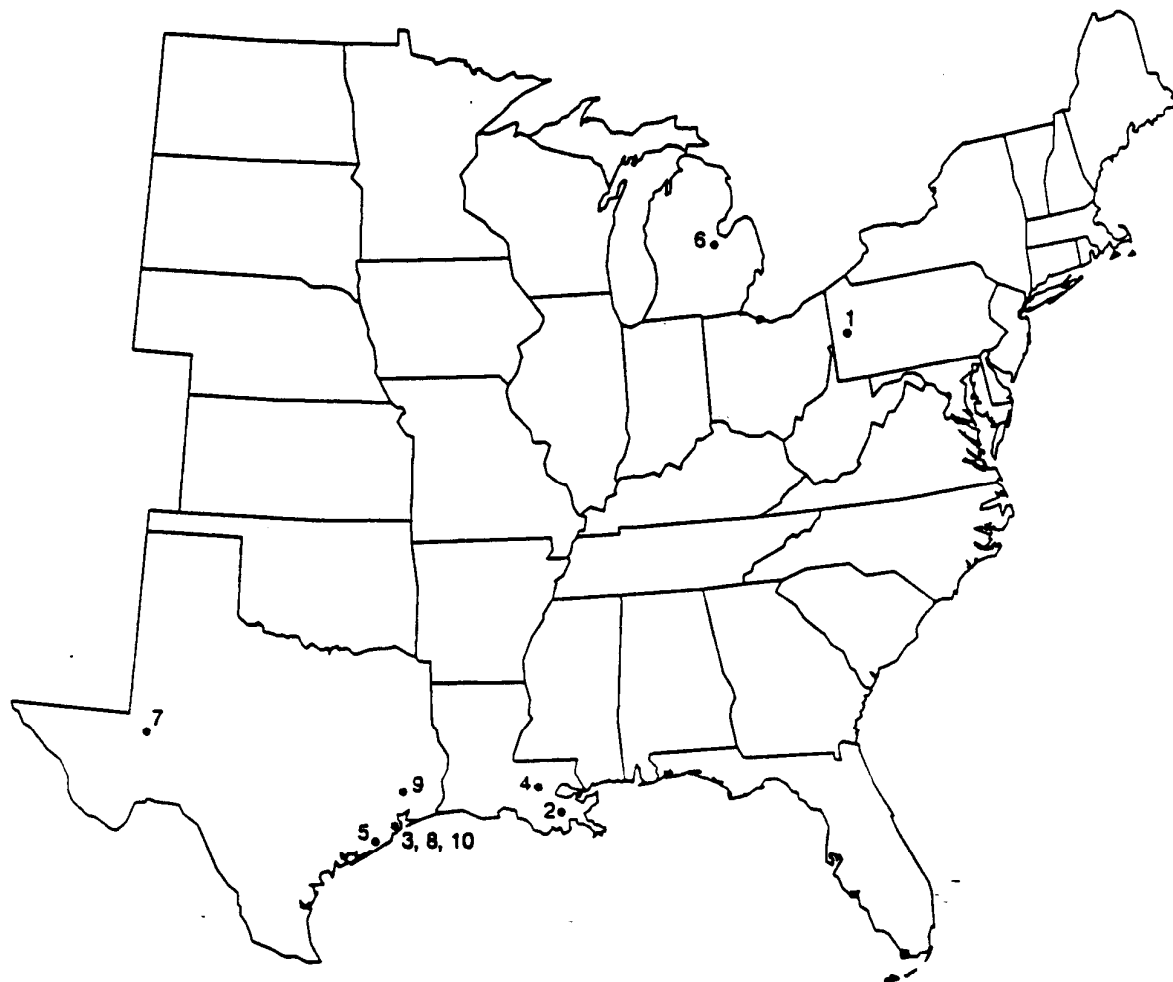

LEGEND OF PLANT NAMES AND LOCATIONS	
1. ARCO, Monaca, PA	6. Dow, Midland, MI
2. Chevron, St. James, LA	7. Rexene Products Co., Odessa, TX
3. Huntsman Chemical, Bayport, TX	8. Amoco Corporation, Texas City, TX
4. Cos-Mar, Carville, LA	9. ARCO, Channelview, TX
5. Dow, Freeport, TX	10. Sterling Chemicals, Texas City, TX

Figure 2. Locations of Plants Manufacturing Styrene

Styrene manufacture by ethylbenzene dehydrogenation is shown by the reaction:

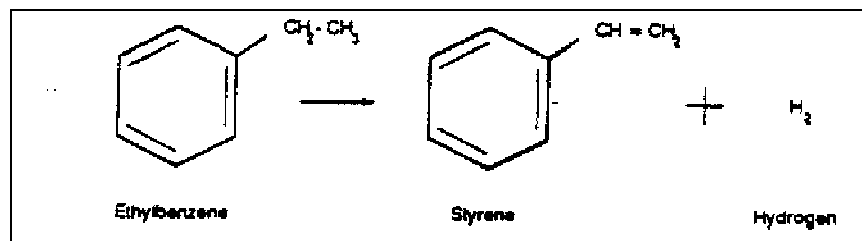

Figure 3 illustrates the process of ethylbenzene dehydrogenation. Purified ethylbenzene is preheated in a heat exchanger (Step 1), and the resultant vapor is mixed continuously with steam at 710°C in the dehydrogenation reactor (Step 2) that contains one of several catalysts such as zinc, aluminum, chromium, iron, or magnesium oxide. The reaction product exits through the heat exchanger and is further cooled in a condenser where water and crude styrene vapors are condensed (Step 3). The hydrogen-rich process gas is recovered and used as a fuel (Step 4) and the process water is purified in a stripper (Step 5) and recycled to the boiler. The remaining crude liquid styrene goes to a storage tank (Step 6). The liquid consists of styrene (37%), ethylbenzene (61%), toluene (1%), benzene (0.7%) and tars (0.3%). Benzene and toluene are removed from the crude styrene in the benzene/toluene column (Step 7). They are then typically separated by distillation. The toluene is sold and the benzene is returned to the ethylbenzene production section or sold. Next, the ethylbenzene column removes ethylbenzene that is directly recycled (Step 8). Tars are removed and the styrene product emerges from the styrene finishing column (Step 9). In some facilities, an ethylbenzene/benzene/toluene stream is separated from the crude styrene initially and processed separately.

Ethylbenzene Hydroperoxidation

Styrene is currently manufactured by ethylbenzene hydroperoxidation at only one facility in the United States.

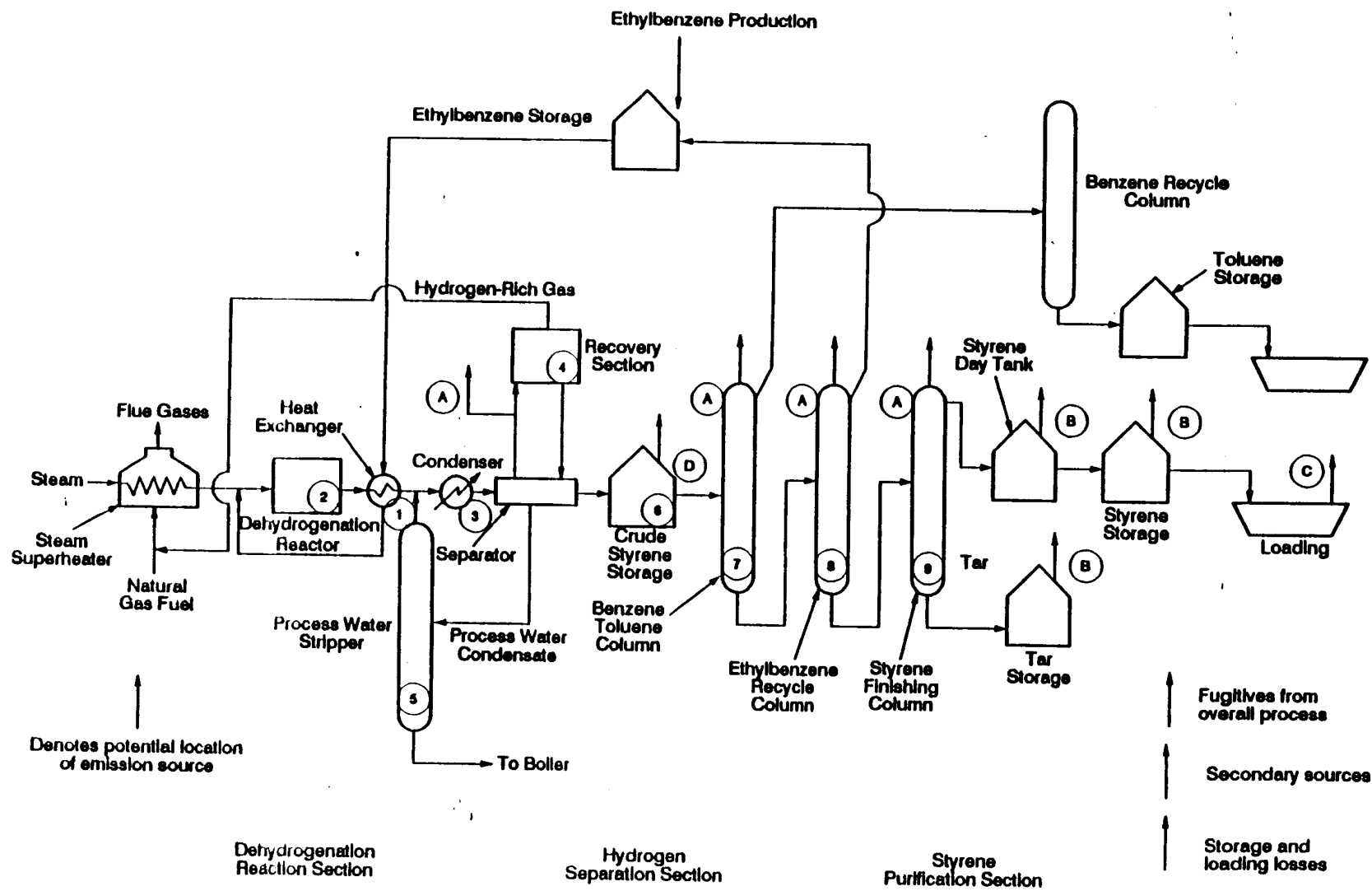
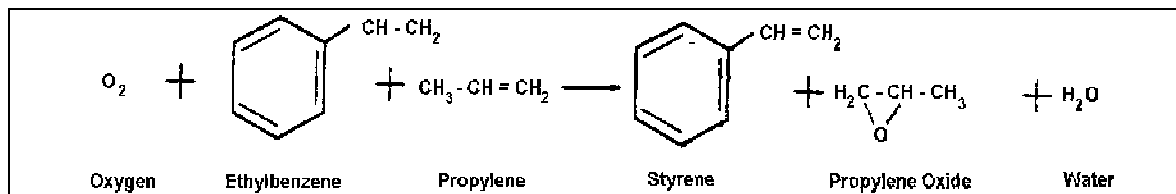

Figure 3. Process Flow Diagram for Styrene Production by Ethylbenzene Dehydrogenation³

This process, shown in Figure 4, is described below. Styrene manufacture by ethylbenzene hydroperoxidation is shown by the reaction:



Ethylbenzene is oxidized with air to produce ethylene hydroperoxide and small amounts of methylbenzylalcohol and acetophenone (Step 1). The exit gas (principally nitrogen) is cooled and scrubbed to recover aromatics before venting. Unreacted ethylbenzene and low-boiling contaminants are removed in an evaporator (Step 2). Ethylbenzene is then sent to the recovery section to be treated before reuse (Step 3).

The mixed stream of methylbenzylalcohol and acetophenone is then dehydrated over a solid catalyst to produce styrene (Step 4). Residual catalyst solids and high-boiling impurities are separated and collected for disposal. The crude styrene goes to a series of distillation columns where the pure styrene monomer product is recovered (Step 5). The residual organic stream contains crude acetophenone, catalyst residue, and various impurities. This mixture is treated under pressure with hydrogen to convert the acetophenone to methylbenzylalcohol (Step 6). Catalyst waste is separate from the methylbenzylalcohol which is returned to the recovery section for processing and reuse. Hydrogen and organic vapors are recovered for use as fuel.

Ethylbenzene hydroperoxide is combined with propylene over a catalyst mixture under high pressure to produce propylene oxide and acetophenone (Step 7). Pressure is then reduced and residual propylene and other low-boiling compounds are separated by distillation (Step 8). The vent stream containing propane and some propylene can be used as a fuel. Propylene is recycled to

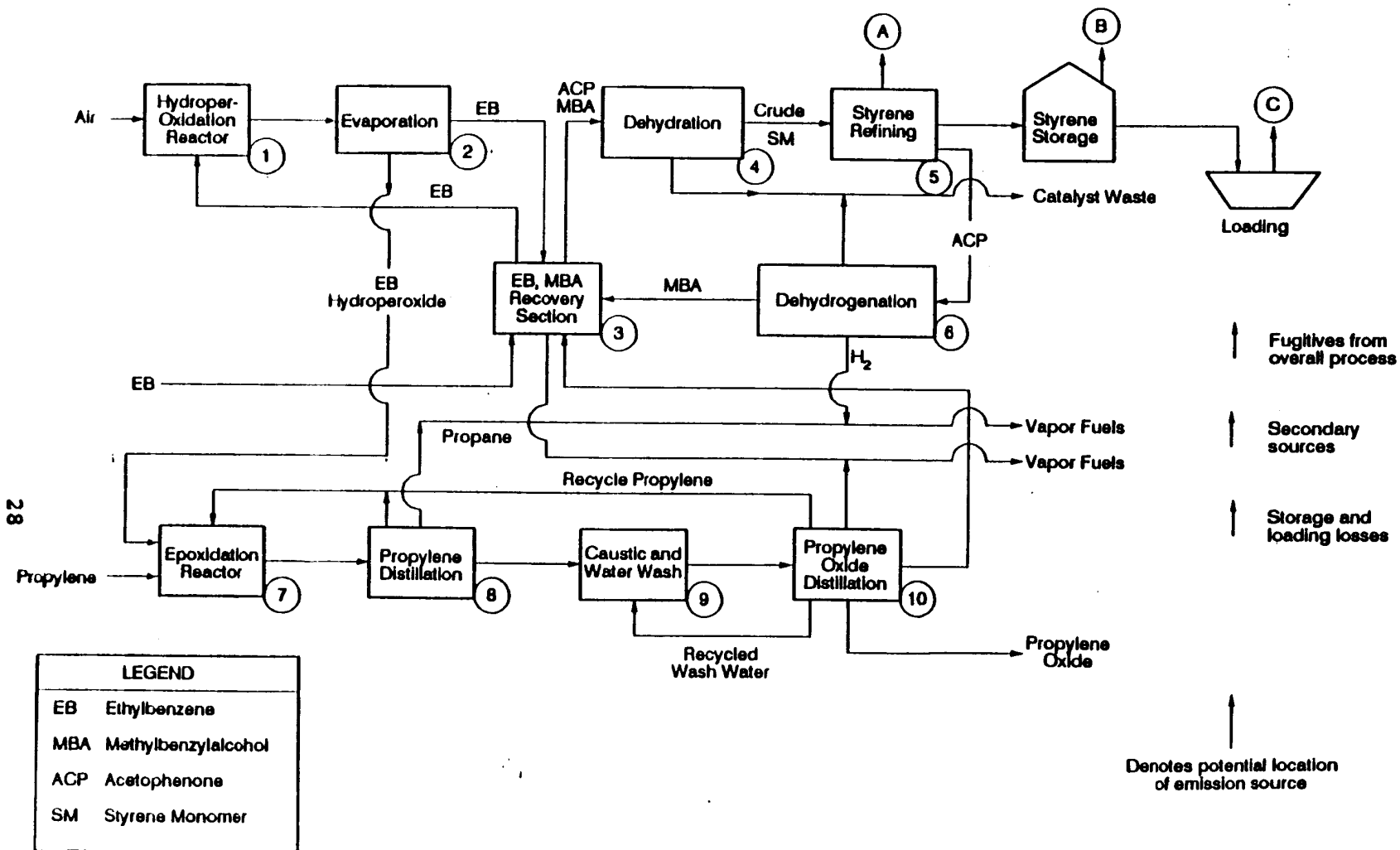

Figure 4. Process Flow Diagram for Styrene Production by Ethylbenzene Hydroperoxidation⁴

the epoxidation reactor. The crude epoxidate is treated to remove acidic impurities and residual catalyst material (Step 9) and the resultant epoxidate stream is distilled (Step 10) to separate the propylene oxide product for storage. Residual water and propylene are recycled to the process train and liquid distillate is recovered as a fuel. The organic layer is routed to the ethylbenzene and methylbenzylalcohol recovery section.

Isothermal Processing

An isothermal process for producing styrene from ethylbenzene was patented in the United States in 1981.⁵ This process is not currently used in the United States, but it is used in several European countries.

As shown in Figure 5, liquid ethylbenzene is vaporized by condensing steam in a heat exchanger (Step 1). Process steam is then introduced into the ethylbenzene stream and the feed mixture is superheated before it enters the molten-salt reactor (Step 2).

In the reactor, the ethylbenzene/steam mixture passes through tubes where it comes into contact with the catalyst and is dehydrogenated. Heat for the dehydrogenation reaction is supplied by molten salt (preferably a mixture of sodium carbonate, lithium carbonate, and potassium carbonate) surrounding the tubes. The reactor is maintained at a uniform wall temperature by circulating the molten-salt mixture through the heat exchanger of a fired heater.

The reaction products are cooled and condensed in a separator (Step 3). The liquid phase is a mixture of organic products: styrene, unreacted ethylbenzene, and small quantities of benzene, toluene, and high-boiling compounds. Styrene is separated from the other liquid constituents, which are then recovered and recycled.

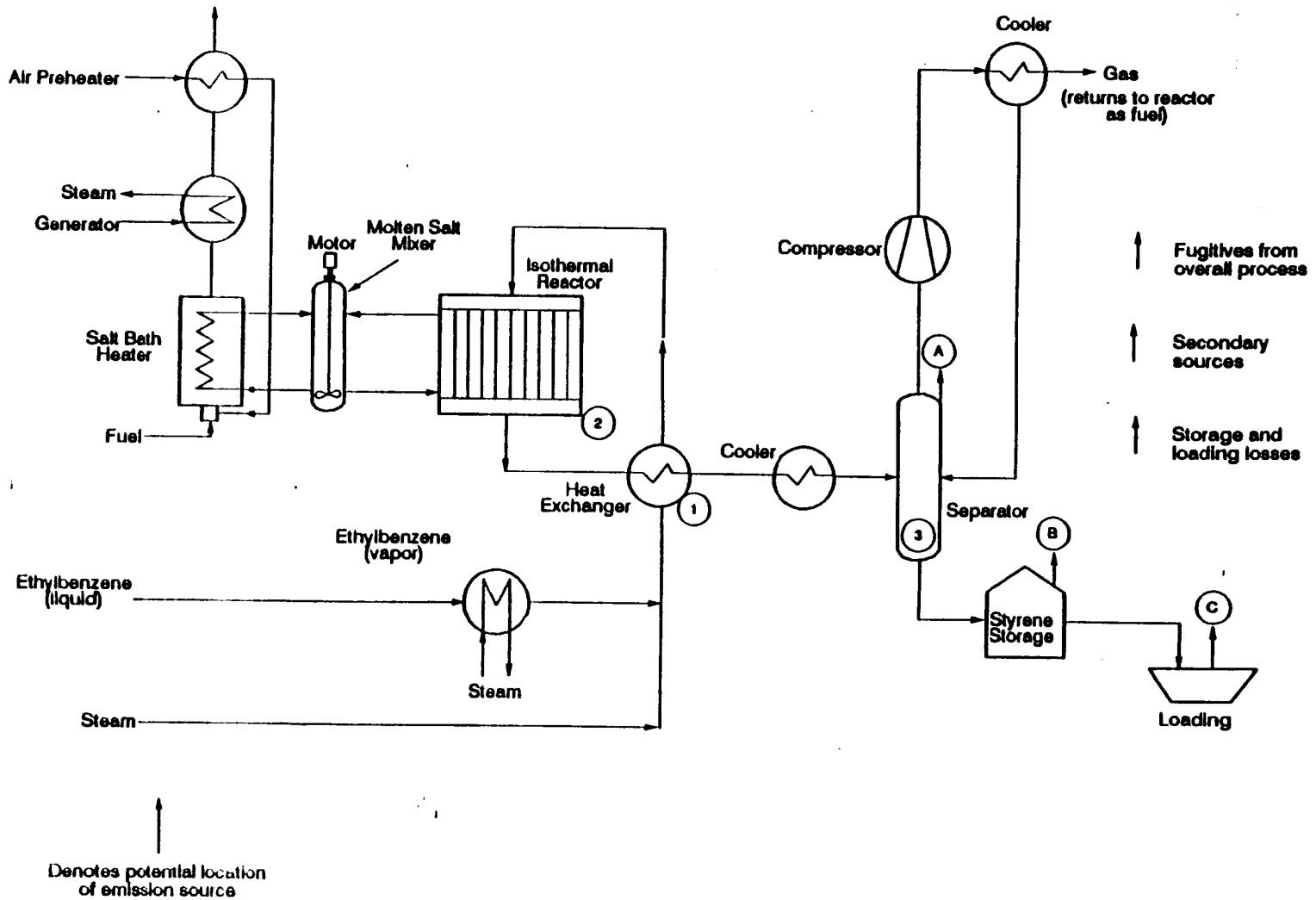

Figure 5. Process Flow Diagram for Styrene Production by Isothermal Processing⁵

The gas phase from the condensation step in the separator consists mainly of hydrogen, with small quantities of carbon dioxide, carbon monoxide, and methane. After these gases are compressed, they are cooled. Condensable products from this final cooling stage are then recovered and recycled to the separator. When hydrogen-rich offgas is used as fuel for the heater of the molten-salt reactor, the fuel requirement for this stage of the process is zero.

EMISSIONS

Most air emissions associated with styrene production arise from loading operations, styrene monomer storage, and equipment leaks. Process vents may also contribute to air emissions in addition to secondary sources (such as waste treatment and disposal facilities).

Process Emissions

Figure 3 shows that during styrene production by ethylbenzene dehydrogenation, process vent discharges (A) of styrene occur primarily from the vacuum column vents. The hydrogen separation vent is only used during startup, shutdown, and during recovery section outages.⁴ The vacuum column vents remove air that leaks into the column, as well as light hydrocarbons and hydrogen that form during dehydrogenation, noncombustibles dissolved in the column feed, and any entrained aromatics. The majority of styrene emissions occur at the first column, the benzene-toluene column, in the distillation train. Although no specific information on controls was available, process vents that have the potential to emit benzene may be controlled to prevent occupational exposure.

Other sources of process emissions from ethylbenzene dehydrogenation are less likely because of the need to operate most processes under a vacuum and because of the heating value of

the gases. No emission estimates for styrene production processes were located in the literature. Also, little information was found on emission controls. One type of control option is incineration, which can reduce styrene emissions by as much as 98 percent.⁴

No information was located in the literature that discussed process emission sources from styrene production by ethylbenzene hydroperoxidation or the isothermal production process. Styrene emissions may occur during the styrene refining process for each of these production processes.

Storage Emissions

Other possible sources of styrene emissions are storage tank losses (B) and handling losses (C) that occur during product loading into drums, tank trucks, tank cars, barges, or ships. Styrene production plants typically have from 2 to 12 small, fixed-roof monomer storage tanks. Storage tank losses are either working losses that occur while filling the tank, or breathing losses due to expansion from temperature changes. Both can be estimated using equations for storage tank emissions given in the U. S. Environmental Protection Agency's "Estimating Air Toxic Emissions from Organic Liquid Storage Tanks" report.⁶ In the absence of specific data on the storage tank, two emission factors were identified in the literature.⁷ Shown in Table 5, both are for uncontrolled emissions. No facilities are known to currently control emissions with floating roof tanks or incineration, although several use condensing units to recover styrene.²

Equipment Leak Emissions

Emissions occur from process equipment components whenever the liquid or gas streams leak from the equipment. Equipment leaks can occur from the following components: pump seals,

TABLE 5. STYRENE STORAGE AND SECONDARY EMISSION FACTORS

Emission Source	Estimated Emission Factor
Storage	
Breathing Loss ^a	0.18 g/L (1.5 lbs/10 ³ lbs) storage capacity
Working Loss ^a	0.02 g/L (0.17 lbs/10 ³ lbs) gallons throughput
Secondary	
Wastewater Treatment ^b	0.50 g/g (0.50 lb/lb) styrene in wastewater

^aSource: Reference 7.

^bSource: Reference 8.

process valves, compressor safety relief valves, flanges, open-ended lines, and sampling connections. Fugitive emissions will be primarily limited to the streams containing no benzene because of the National Emission Standard for Hazardous Air Pollutants (NESHAP) that applies to equipment in benzene service. This NESHAP addresses all equipment components handling process streams containing 10 percent by weight or greater benzene. Emission estimates can be calculated in the five ways described in the EPA publication "Protocols for Generating Unit-Specific Emission Estimates."⁹ The methods differ in complexity; however, the more complex, the better the emission estimate.

The simplest method requires that the number of each component type be known. Furthermore, for every component the styrene content of the stream and the time the component is in service is needed. This information is then multiplied by the EPA's average emission factors for the Synthetic Organic Chemical Manufacturing Industries (SOCMI) shown in Table 6. This method should only be used if no other data are available, as it probably results in an overestimation of actual equipment leak emissions. For each component, estimated emissions are:

$$\left[\begin{array}{c} \text{No. of} \\ \text{equipment} \\ \text{components} \end{array} \right] \times \left[\begin{array}{c} \text{Weight \%} \\ \text{styrene in the} \\ \text{stream} \end{array} \right] \times \left[\begin{array}{c} \text{Component-specific} \\ \text{emission factor} \end{array} \right] \times \left[\begin{array}{c} \text{No. hrs/yr in} \\ \text{styrene service} \end{array} \right]$$

To obtain better equipment leak emission estimates, one of the more complex estimation methods should be used. These other four methods require that some level of emission measurement for the facility's equipment components be collected. These are described briefly, and the reader is referred to the Protocols document for the calculation details.

TABLE 6. AVERAGE EMISSION FACTORS FOR FUGITIVE EMISSIONS

Equipment	Service	Emission Factor	
		(Kg/hr/ Source)	(Lb/hr/ Source)
Valves	Gas	0.0056	0.012
	Light Liquid	0.0071	0.016
	Heavy Liquid	0.00023	0.00051
Pump Seals	Light Liquid	0.0494	0.109
	Heavy Liquid	0.0214	0.472
Compressor Seals	Gas/Vapor	0.228	0.503
Pressure Relief Seals	Gas/Vapor	0.104	0.229
Flanges	All	0.00083	0.0018
Open-Ended Lines	All	0.0017	0.0037
Sampling Connections	All	0.0150	0.033

Source: Reference 9.

The leak/no leak approach is based on a determination of the number of leaking and non-leaking components. These values are then multiplied by two different sets of EPA-derived emission factors. The third method groups screening results into three ranges: 0-1,000 ppmv; 1,001-10,000 ppmv; and greater than 10,000 ppmv. The number of each component falling in a particular range is multiplied by the component-specific emission factor for that range. These emission factors have also been developed by EPA. The fourth procedure uses screening data in correlation equations derived from earlier work by EPA.

The fifth method gives the facility the option to develop its own correlation equations but requires more rigorous testing, bagging and analyzing of equipment leaks to determine mass emission rates.

Although no specific information on controls used by the industry was identified, equipment components in benzene service will have some controls in place. Generally, control of fugitive emissions will require the use of sealless or double mechanical seal pumps, an inspection and maintenance program, as well as replacement or leaking valves and fittings. Typical controls for equipment leaks are listed in Table 7. Additionally, some leakless equipment is available such as leakless valves¹⁰ and sealless pumps.²

Secondary Emissions

Secondary emissions occur at both on-site and off-site facilities that treat and dispose of wastewater, liquid waste, or solid waste. Waste streams may be generated for any of the operations shown in Figures 3, 4, and 5.

For secondary emissions resulting from treatment of wastewater containing styrene, one reference estimated that approximately 50 percent of the styrene present in the water may

TABLE 7. CONTROL TECHNIQUES AND EFFICIENCIES
 APPLICABLE TO EQUIPMENT LEAK EMISSIONS

Equipment Component (Emission Source)	Control Technique	Percent Reduction ^a
Pump Seals		
Packed and Mechanical	Seal area enclosure vented to a combustion device	100
	Monthly LDAR ^b	61
	Quarterly LDAR	32
	Semiannual LDAR	0
	Annual LDAR	0
Double Mechanical ^c	N/A ^d	--
Compressors	Vent degassing reservoir to combustion device	100
Flanges	None available	0
Valves		
Gas	Monthly LDAR	73
	Quarterly LDAR	64
	Semiannual LDAR	50
	Annual LDAR	24
Liquid	Monthly LDAR	59
	Quarterly LDAR	44
	Semiannual LDAR	22
	Annual LDAR	0

TABLE 7. (Continued)

Pressure Relief Devices		
Gas	Monthly LDAR	50
	Quarterly LDAR	44
	Rupture Disk	100
Liquid	N/A	--
Sample Connections	Closed-purge sampling	100
Open-ended Lines	Caps on open ends	100

^aIf Reference 10 indicated a negative reduction for a control technique, zero was used.

^bLDAR = Leak detection and repair.

^cAssumes the seal barrier fluid is maintained at a pressure above the pump stuffing box pressure and the system is equipped with a sensor that detects failure of the seal and/or barrier fluid system.

^dN/A = Not applicable. There are no VOC emissions from this component.

Source: References 2 and 10.

be released during processing at a publicly owned treatment works (POTW) facility.¹¹ This emission factor is given in Table 5. No information was available on the styrene content in the wastewater. Furthermore, handling and processing practices will differ with each facility; therefore, the emission factor should be reviewed as providing an order-of-magnitude estimate at best.

REFERENCES FOR SECTION 4

1. SRI International. 1990 Directory of Chemical Producers, United States of America. Menlo Park, California. 1990.
2. A. T. Kearney. Impact Analysis of the EPA Office of Drinking Water Proposal to Regulate Styrene. Styrene Information Research Center. 1989.
3. U. S. Environmental Protection Agency. Benzene Emissions from the Ethylbenzene/Styrene Industry - Background Information for Proposed Standards. EPA-450/3-70-035a. U. S. Environmental Protection Agency, Research Triangle Park, North Carolina. 1980.
4. Cruse, P. A. Locating and Estimating Air Emissions from Sources of Benzene. EPA-450/4-84-007q. U. S. Environmental Protection Agency, Research Triangle Park, North Carolina. 1988.
5. Short, H. C. and L. Bolton. New Styrene Process Pares Production Costs. Chemical Engineering. August: 30-31. 1985.
6. Murphy, P. Estimating Air Toxics Emissions From Organic Liquid Storage Tanks. EPA-450/4-88-004. U. S. Environmental Protection Agency, Research Triangle Park, North Carolina. 1988.
7. Stockton, M. B. and J. H. E. Stelling. Criteria Pollutant Emission Factors for the 1985 NAPAP Emissions Inventory. EPA-600/7-87-015. U. S. Environmental Protection Agency, Washington, D.C. p. 134. 1987.
8. Pope, A. A., et al. Toxic Air Pollutant Emission Factors - A Compilation for Selected Air Toxic Compounds and Sources. EPA-450/2-88-006. U. S. Environmental Protection Agency, Research Triangle Park, North Carolina. 1988.
9. U. S. Environmental Protection Agency. Protocols for Generating Unit-Specific Emission Estimates for Equipment Leaks of VOC and VHAP. EPA-450/3-88-010. U. S. Environmental Protection Agency, Research Triangle Park, North Carolina. 1988.
10. U. S. Environmental Protection Agency. Fugitive Emission Sources of Organic Compounds--Additional Information on Emissions, Emission Reductions, and Costs. EPA-450/3-82-010. U. S. Environmental Protection Agency, Research Triangle Park, North Carolina. April 1982.

11. White, T. S. Volatile Organic Compound Emissions from Hazardous Waste Treatment Facilities at Downstream POTW. Prepared for the U. S. Environmental Protection Agency, Research Triangle Park, North Carolina. pp. 5-6. 1987.

SECTION 5

EMISSIONS FROM MAJOR USES OF STYRENE

This section discusses emissions from major industrial processes that use styrene as a feedstock. The processes described are production of polystyrene (PS) polymer, styrene-butadiene copolymers (S-B, SBR), styrene-acrylonitrile copolymer (SAN), acrylonitrile-butadiene-styrene copolymer (ABS), and unsaturated polyester resins (UPR). In addition, product and process descriptions are provided for the miscellaneous styrene copolymers: styrene-butadiene-vinylpyridine (SBV) latex, methyl methacrylate-butadiene-styrene (MBS) resins, and methyl methacrylate-acrylonitrile-butadiene-styrene (MABS) polymer. Process flow diagrams are included as appropriate, with specific streams or vents in the figures labeled to correspond with the discussion in the text.

Emissions of styrene are expected from all facilities that produce the above listed resins. However, insufficient information is available to develop emission factors for fugitives or process emission sources. Available information is provided in each subsection. The reader is encouraged to contact State or local air pollution control agencies, the toxic release inventory, and specific production facilities for information on styrene emissions and control technologies.

POLYSTYRENE PRODUCTION

Polystyrene is produced by the polymerization of styrene monomer. The polymer is available in a wide range of formulations including crystal, high impact and expandable (EPS). Crystal PS is the general purpose grade. It is a clear, rigid plastic with excellent electrical and insulation properties and low impact resistance.¹ To increase the toughness of the polystyrene plastic, rubber particles (usually polybutadiene) may

be incorporated into the polymer matrix. This rubber-modified form is known as high impact PS.² Expandable polystyrene is produced by the addition of a volatile blowing agent to the polystyrene which causes the polymer to expand when heated. The blowing agent may be added during the polymerization process or during the fabrication process.³

Polystyrene is used in injection and extrusion processes to produce a wide variety of products. The major end use for PS is in packaging. The resin also finds applications in the building, electronics, furniture, housewares, and recreational marketing areas. Polystyrene is the leading resin used for making toys. Injection molding is used to make products such as tumblers, tooth brush handles, computer disk reels, pill bottles, and toys. Extrusion is used to make egg cartons, meat/poultry trays, and fast-food packages. Crystal PS is used to make fast-food packages and egg cartons. High impact PS is used to produce fast-food cups, lids, and containers, toys, containers for food, fruit juices, and dairy products, kitchen housewares, and small appliances. Expandable PS, which is easy to process, is used to make disposable drinking cups, loose fill packaging, insulation, and packaging shapes. Polystyrene is commonly marketed in bead or pellet form; however, some is captively converted to film, sheet, or foam.⁴

Polystyrene is currently produced by 17 companies at 34 facilities in 16 States. These facilities and their 1990 production capacities are listed in Table 8.⁵ Manufacture of polystyrene is the major end use of styrene monomer, consuming approximately 68 percent of the styrene produced in the United States.⁶

Process Description

Polystyrene may be produced by the suspension, mass (bulk), solution, and emulsion processes. The suspension process is

TABLE 8. POLYSTYRENE PRODUCTION FACILITIES

Company	Location	Annual Capacity	
		(Mg/yr)	(MM lb/yr)
American Polymers	Oxford, MA	48,081	106
Amoco	Joliet, IL	96,615	213
	Torrance, CA	14,061	31
	Willow Springs, IL	32,659	72
BASF	South Brunswick, NJ	79,379	480
Chevron	Marietta, OH	21,724	480
Dart Polymers	Owensboro, KY	31,751	70
Dow Chemical	Gales Ferry, CT	61,235	135
	Ironton, OH	90,718	200
	Joliet, IL	106,594	235
	Midland, MI	171,458	378
	Pevely, MO	54,431	120
	Torrance, CA	109,299	242
Fina Oil	Calumet City, IL	90,178	200
	Carville, LA	290,299	640
G.E. Huntsman Corp.	Selkirk, NY	31,751	70
Goodson Polymers	Troy, OH	65,317	144
Huntsman Chemical	Belpre, OH	136,078	300
	Chesapeake, VA	181,437	400
	Peru, IL	172,365	380
	Rome, GA	20,412	45
Kama	Hazleton, PA	15,876	35
Mobil	Holyoke, MA	36,287	80
	Joliet, IL	165,561	365
	Santa Ana, CA	31,751	70
Monsanto	Addyston, CA	81,647	180

TABLE 8. (Continued)

Polysar	Akron, OH	54,431	120
	Decatur, AL	63,503	140
	Leominster, MA	72,575	160
	Springfield, MA	71,647	180
Scott Polymers	Fort Worth, TX	34,927	77
Tenneco	City of Industry, CA	29,948	55
TOTAL		3,045,419 ^a	6,714

^aNumbers do not total due to rounding.

NOTE: The listing on Table 8 is subject to change as market conditions change, facility ownership changes, plants are closed down, etc. The reader should verify the existence of particular facilities by consulting current listings and/or the plants themselves. The level of styrene emissions from any given facility is a function of variables such as capacity, throughput, and control measures, and should be determined through direct contact with plant personnel. These operating plants and locations were current as of January 1990.

Source: Reference 5.

operated in a batch mode, whereas the mass and solution processes are operated in the continuous mode.⁷ The mass and suspension methods are commercially significant.⁷ Use of the emulsion process for PS production has decreased significantly since the mid-1940's.⁸ It is not used for the production of crystal PS because the soap solution (emulsifier) adversely affects the clarity and electrical-insulation characteristics of the product.³ Therefore, the emulsion process will not be discussed here.

To produce impact grade polystyrene, the rubber component may be incorporated by mechanical means after styrene polymerization or it may be added to the polymerization reactor along with the styrene monomer. If mechanical means are used, rubber latex may be added to polystyrene latex followed by coagulation and drying, or dry rubber can be milled with dry polystyrene. Alternatively, chopped preformed unsaturated rubber can be dissolved into styrene monomer and then the mixture can undergo polymerization by any of the three processes described below.³ Most impact PS is produced by suspension polymerization.³

Expandable polystyrene is produced by modifying the batch suspension process. A blowing agent, such as n-pentane, may be added to the reactor before or after polymerization and is absorbed by the polystyrene. The post-impregnation process is more commonly used.⁸ In this method the finished polystyrene product bead from the suspension process is fed through a second suspension process train where the blowing agent is impregnated into the product beads through the use of temperature and applied pressure.

Suspension Process--

The suspension process (Figure 6) is a batch polymerization process that may be used to produce crystal, impact or expandable polystyrene beads. In this process, polymerization is carried out in an aqueous medium to permit removal of the heat of there action.¹ The polystyrene polymer is formed in small beads which are easily separated from the aqueous phase.

Styrene monomer from storage is first washed to remove any inhibitors of the polymerization reaction (Step 1). The washed styrene is transferred to a mixing tank where it is combined with a free radical initiator (Step 2). The styrene is then fed into an agitated reactor along with water, initiator, a monomer soluble suspending agent and suspension stabilizer (Step 3). A blowing agent or rubber may be added at this time for the production of expandable PS or high impact PS respectively. Both the blowing agent and the rubber may also be added later as part of a post polymerization process. Following polymerization, the polymer beads are transferred to a wash tank where they are washed with acid to remove initiators and suspension stabilizers (Step 4). The wet beads are sent to a centrifuge (Step 5) and then a dryer (Step 6) for dewatering and drying. The beads are passed to a devolatilization extruder for recovery of unreacted styrene monomer (Step 7). Recovered monomer is recycled into the polymerization reactor. The purified polymer beads are dried and sent to product storage.³

Mass Process--

The mass process uses no water or organic solvents and is the simplest process for producing polystyrene. As shown in Figure 7, there are four major stages in the mass process: prepolymerization, polymerization, devolatilization, and extrusion. Styrene monomer is stripped of inhibitors in a steam stripper (Step 1) then pumped into a stirred prepolymerization

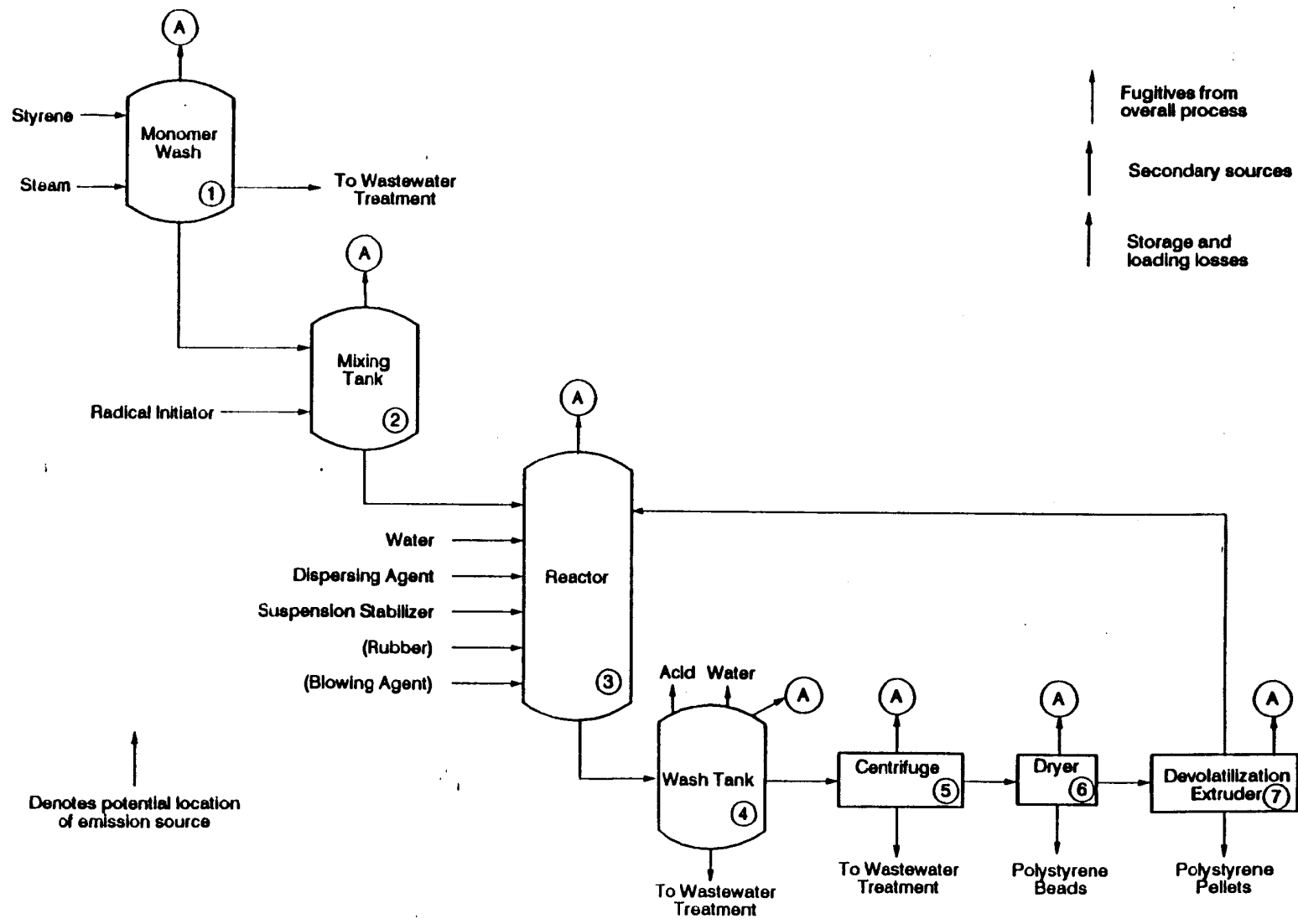

Figure 6. Polystyrene Production by Suspension Polymerization³

reactor equipped with a reflux condenser operating under reduced pressure (Step 2). Reaction temperature is controlled by removing some of the monomer vapor, condensing it, and then returning the liquid monomer to the reactor. Polymerization may be initiated either thermally or through the use of chemical initiators. In this reactor monomer conversion proceeds to 25 to 35 percent. The polymer melt is then fed through a series of stirred reflux reactors (Step 3). The reaction temperature is continually raised to promote polymerization and reduce the viscosity of the polymer mass. Final temperatures typically range from 150 to 200°C. The polymer melt is transferred to a static devolatilizer (Step 4) where unreacted monomer and low molecular weight polymers are flashed off distilled and recycled (Step 5). The stripped polymer is fed through a vent extruder and pelletized (Step 6).³

Solution Process--

A block diagram of the polystyrene solution process is presented in Figure 8. In this process, polymerization proceeds in a solvent medium. In Step 1, styrene monomer is steam stripped to remove any inhibitors of the polymerization reaction. The washed styrene monomer is mixed with a solvent (such as ethylbenzene) and an initiator, then fed through a series of agitated reactors (Step 2). The initial ethylbenzene concentration may range from 5 to 25 percent. Following polymerization the polymer mix is sent to a flash tank for the removal of unreacted styrene and solvent (Step 3). Recovered styrene and solvent are recycled with the reactor feed. The purified polymer is fed through an extruder and chopped into pellets (Step 4).³

Emissions

Typical emission sources at a polystyrene plant include process vents, storage tanks, equipment leaks, secondary sources,

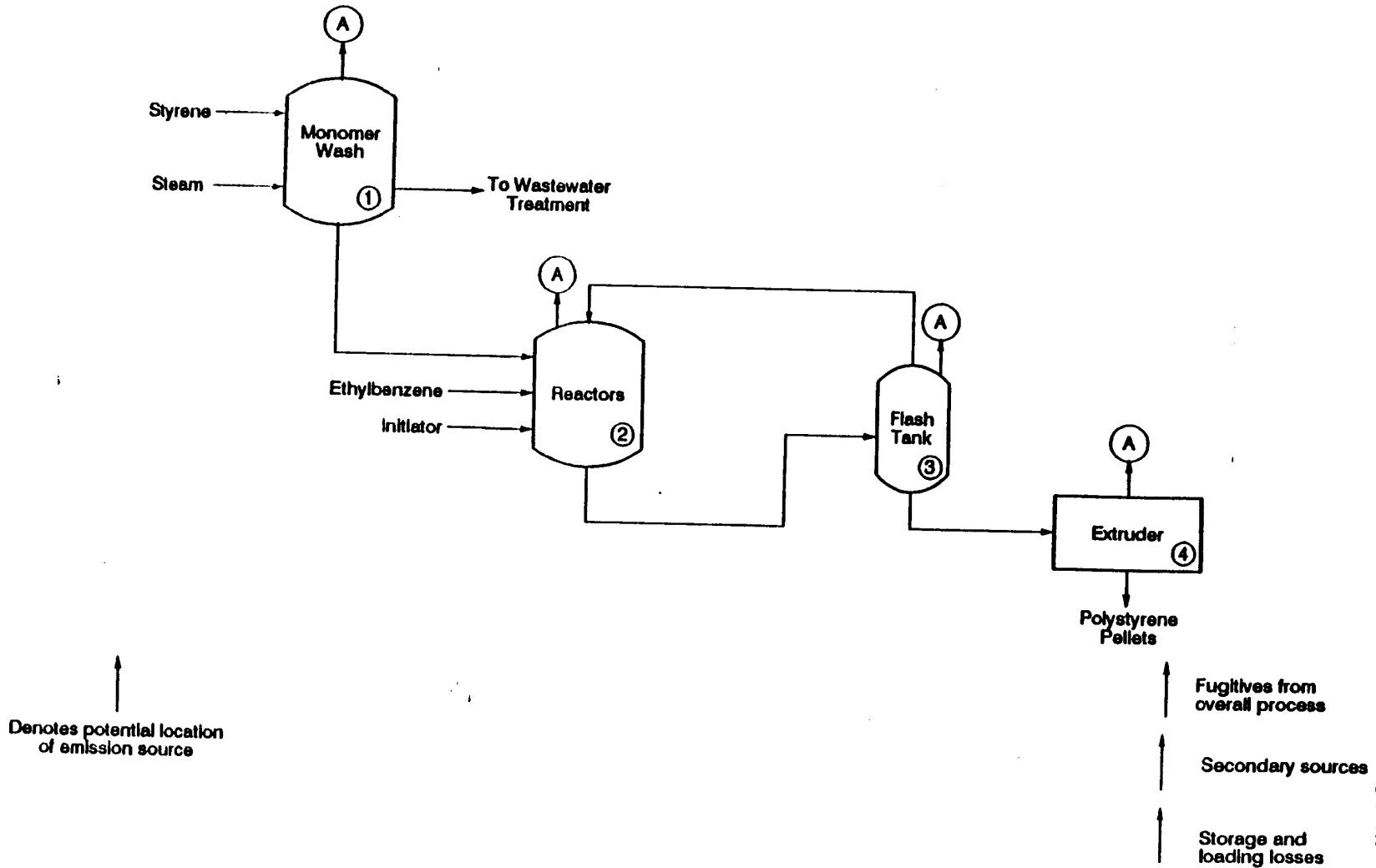

Figure 8. Polystyrene Production by Solution Polymerization³

and transfer and handling operations. Styrene may also be emitted during accidental or emergency releases.³

Styrene may be emitted from reactor vents, mixing tanks, wash tanks, devolatilizer condenser vents, styrene recovery unit condenser vents, and during polymer drying and finishing stages.³ The monomer storage tank, the mixing/dissolving tanks, and the reactor feed tank typically have fixed roofs.⁴ Emissions from these sources are relatively small and are due to normal breathing and filling of the tanks.⁴ Vapor balance use on working condenser is the largest styrene emission source in a polystyrene plant; however, the quantity of emissions is not particularly large.^{4,9} Following the devolatilization step, residual styrene monomer in the polymer is typically less than one percent.³ The extruder pelletizer vent is potentially the second largest styrene emission source.⁴

Vent emissions may be controlled by routing the process streams to a flare or a blowdown tank.⁶ Conservation valves can be installed on holding and mixing tanks.⁴ Vapor return lines to tank cars or trucks can be installed to reduce styrene losses during storage tank filling.⁴

Fugitive emissions result from leaks in flanges, valves, pumps, open drains, and other equipment components. Control of these emissions may be accomplished through a regular inspection and maintenance program as well as by equipment modification.

The mode of operation also influences emissions. Batch processes generally have high conversion efficiencies, leaving only small amounts of unreacted styrene to be emitted if the reactor is purged or opened between batches.⁸ In continuous processes a lower percentage of styrene is converted to polystyrene, and thus larger amounts of unreacted styrene may be emitted.⁸

Facilities using batch processes may manufacture a wide variety of polystyrene products. Styrene emissions vary with the product grade with higher emissions expected during the manufacture of lower molecular weight products.¹⁰ Typical emission factor ranges suggested by the Chemical Manufacturers Association (CMA) for three batch process vents are presented in Table 9.

For plants using the continuous process, a wide range of emission rates have been found, depending in part on the type of vacuum system used.⁸ The shift from the use of steam eductors to vacuum pumps results in lower emission factors.¹⁰ Table 9 presents VOC emission factors given by CMA for the continuous polystyrene plants. Emission factors for the same vents based on information from other industry sources are also presented in Table 9.⁹

STYRENE-BUTADIENE COPOLYMER PRODUCTION

Styrene-butadiene copolymers are composed of monomer units of styrene and butadiene. The copolymers may be categorized into two general types: styrene-butadiene rubber (SBR) and styrene-butadiene latex (S-B latex), based on percent styrene composition. However, the exact nomenclature for the different types of styrene-butadiene copolymers is often used differently between the plastics and rubber industry.

SBR copolymers contain less than 45 percent styrene and have rubber-like qualities. They are characterized by processability, heat aging, and abrasion resistance. SBR can be in a solid (elastomer) or latex (elastomer emulsion) form. The solid form of the copolymer is also known as crumb.

As the styrene content is increased above 45 percent, copolymers become more plastic-like and are in latex form. They may be referred to as S-B latex. S-B latex is characterized by

TABLE 9. EMISSION FACTORS FOR POLYSTYRENE PRODUCTION

Emission Source	Process Type	Uncontrolled Emission Rate		Stream Composition	Ref.
		(Kg Styrene/ Mg Resin)	(Lb Styrene/ Ton Resin)		
Feed dissolver (mixing tank)	Continuous	0.009	0.018	92% styrene ^a 7.5% polybutadiene 1.5% other	9
Reactor heading vent	Batch	0.15-1.35	0.3-2.7	N/A ^b	10
Devolatilizer condenser vent	Batch	0.25-0.75	0.5-1.5	N/A	10
	Continuous	0.05-0.06	0.10-0.12	N/A	10
	Continuous	0.05-2.96	0.10-5.92	21.8% styrene 78.2% steam	9
Styrene recovery unit condenser vent	Continuous	0.05-0.06	0.10-0.12	N/A	10
	Continuous	0.05-0.13	0.10-0.26	2.1% styrene 97.9% steam	9
Extruder quench vent	Batch				
	Continuous	0.15-0.30	0.30-0.60	N/A	10
	Continuous	0.009-0.01 0.15	0.018-0.02 0.30	N/A trace styrene 99.99% steam	10 9

^aIt is assumed that numbers do not total due to rounding.

^bNot available.

excellent resistance to water and very good electrical insulation qualities.

Styrene-butadiene copolymers account for 13 percent of national styrene consumption.⁶ SB copolymers are produced by 13 companies at 23 facilities in 12 states. Elastomer and latex production facilities are listed in Tables 10 and 11, respectively. The U. S. annual production capacity of SB copolymers for 1990 is estimated to be 1,575,691 Mg (3474 MM lbs), 61 percent elastomer and 39 percent latex.⁵ Most SBR elastomer is used to manufacture automobile tires and related automotive products. In the United States, SBR has the highest production rate of all synthetic rubbers. However, due to the longer life of tires and the use of smaller tires, U. S. demand for SBR is declining. Other automotive uses of SBR include belts, hoses, gaskets, and seals. Non-automotive uses of SBR include cable insulation, hoses, tubes, conveyor belts, floor tiles, shoe soles, adhesives, and sporting goods. Over 80 percent of styrene-butadiene latexes are used in the carpet/upholstery backing and paper coating industries.³

Process Description

Styrene-butadiene elastomer is manufactured by two types of polymerization processes: (1) the emulsion process, in which the monomers are dispersed in water, and (2) the solution process, in which the monomers are dissolved in a solvent. The emulsion process is more commonly used. Styrene-butadiene latex is produced by the emulsion process in a similar manner to SBR, except that the emulsion breaking (coagulation) and drying steps are omitted.

Emulsion Process--

A flow diagram of the emulsion process for SBR elastomer production is shown in Figure 9. In Step 1, fresh styrene and

TABLE 10. SBR ELASTOMER PRODUCTION FACILITIES

Company	Location	Annual Capacity	
		(Mg/yr)	(MM lb/yr)
Ameripol	Port Neches, TX	336,000	741
Copolymer	Baton Rouge, LA	125,000	276
Firestone	Lake Charles, LA	120,000	265
General Tire	Odessa, TX	90,000	198
Goodyear	Beaumont, TX	20,000 ^a	44
	Houston, TX	<u>305,000</u>	<u>672</u>
TOTAL		996,000	2,196

^aFor captive use.

NOTE: This listing is subject to change as market conditions change, facility ownership changes, plants are closed down, etc. The reader should verify the existence of particular facilities by consulting current listings and/or the plants themselves. The level of styrene emissions from any given facility is a function of variables such as capacity, throughput, and control measures, and should be determined through direct contact with plant personnel. These operating plants and locations were current as of January 1990.

Source: Reference 5.

TABLE 11. STYRENE-BUTADIENE LATEX PRODUCTION FACILITIES

Company	Location	Annual Capacity	
		(Mg/yr)	(MM lb/yr)
SBR LATEX^a			
BASF	Chattanooga, TN	9,030	64
B.F. Goodrich	Akron, OH	907 ^b	2
GenCorp	Mogadore, OH	6,804 ^b	15
Goodyear	Akron, OH	3,175 ^c	7
	Calhoun, GA	5,443 ^b	12
	Houston, TX	22,680	50
	TOTAL	68,039	150
S-B LATEX^d			
BASF	Chattanooga, TN	49,895	110
	Monaca, PA	24,948	55
B.F. Goodrich	Akron, OH	907	2
Colloids	Gastonia, GA	15,876	35
Dow Chemical	Dalton, GA	181,437	400
	Freeport, TX		
	Gales Ferry, CT		
	Midland, MI		
	Pittsburg, CA		
GenCorp	Mogadore, OH	84,822	187
Goodyear	Calhoun, GA	39,916	88
Reichhold	Cheswold, DE	69,853	154
	Kensington, GA		
W.R. Grace	Owensburg, KY	4,536	10
Unocal	Charlotte, NC	27,216	60
	La Mirada, CA	12,247	27
	TOTAL	511,652 ^e	1,128

^a<45% styrene

^bCapacity includes s-b-vinylpyridine latex.

^cCapacity is all s-b-vinylpyridine latex.

^d>45% styrene

^eNumbers do not total due to rounding.

NOTE: This listing is subject to change as market conditions change, facility ownership changes, plants are closed down, etc. The reader should verify the existence of particular facilities by consulting current listings and/or the plants themselves. The level of styrene emission from any given facility is a function of variables such as capacity, throughput, and control measures, and should be determined through the direct contact with plant personnel. These operating plants and locations were current as of January 1990.

Source: Reference 5.

58

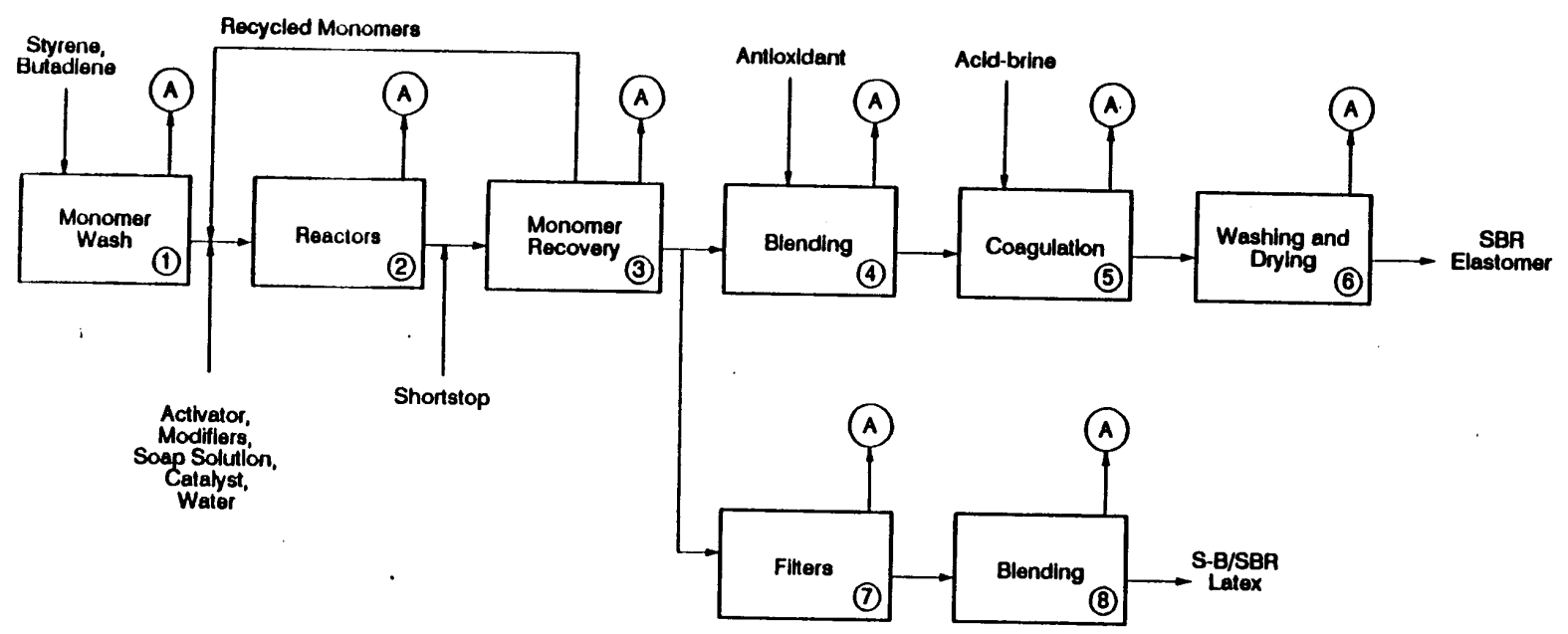

↑
Denotes potential location
of emission source

↑ Fugitives from overall process
↑ Secondary sources
↑ Storage and loading losses

Figure 9. S-B/SBR Production by Emulsion Polymerization¹¹

3204190F

butadiene monomers are washed to remove inhibitors which may have been added to prevent premature polymerization. The washed monomers are mixed with recycled monomers, modifiers, activators, soap solution (emulsifier), and catalyst and charged into a polymerization reactor (Step 2). A typical recipe for emulsion SBR is presented in Table 12. Polymerization proceeds in a stepwise fashion through a chain of reactors that allow the facility a high degree of flexibility in producing different grades of SBR. Either a hot (50°C) or a cold (4°C) process may be used. The reaction is normally carried out to a 60 percent monomer conversion after which a shortstop solution is added to prevent further polymerization. The latex reaction mixture is sent to a vacuum flash tank for recovery of unreacted butadiene and then to a steam stripping unit for the recovery of unreacted styrene (Step 3). After the monomer is removed, the latex may take one of two routes. In one route, SBR elastomer is formed through emulsion breaking and drying steps. The stripped latex is transferred to a blending and storage tank where an antioxidant is added to prevent the polymer from reacting with oxygen or ozone (Step 4). The latex stream is then pumped into coagulation tanks where the emulsion is broken (Step 5). An acid-brine mixture (aluminum sulfate) is added which causes the rubber (known as crumb) to precipitate out. The rubber copolymer is then sent to a washing and drying section (Step 6) and pressed into bales.^{11,12}

The second route, which produces styrene butadiene latex as the end product, includes the same steps as the elastomer production except for the latex coagulation and final rinsing, drying and baling. However, in some instances the latex polymerization reaction may be continued to a 98 or 99 percent conversion--as opposed to 60 percent conversion for emulsion crumb rubber. Therefore, in these instances, the monomer recovery steps are omitted. The latex product is also passed through a series of screen filters (Step 7) to remove large

TABLE 12. TYPICAL RECIPE FOR EMULSION SBR

Components	Weight Percent	Function
Butadiene	25.0	Monomer
Styrene	10.0	Monomer
d-Isopropyl Benzene Hydroperoxide	<0.1	Catalyst
Ferrous Sulfate	<0.1	Activator
Tert-Dodecyl Mercaptan	0.1	Modifier
Potassium Pyrophosphate	0.1	Buffer
Rosin Acid Soap	1.4	Emulsifier
Water	63.0	

Source: Reference 11.

solids before it is sent to the blending tank for storage (Step 8).^{11,12}

Solution Process--

A flow diagram for the solution process is shown in Figure 10. In this process, polymerization takes place in an organic solvent medium, usually hexane. Freshly washed (Step 1) and recycled styrene and butadiene monomers and the organic solvent are pumped through dryers to remove any water (Step 2), then blended together to form the mixed feed. The feed may be sent to a dryer as well (Step 3) to remove any residual traces of water. The mixture is added to the polymerization reactor along with a catalyst (Step 4). Polymerization takes place through a series of reactors and proceeds to greater than 90 percent conversion. A shortstop solution is added to halt further polymerization. The reaction product is in the form of rubber cement. It is pumped to product storage (Step 5) where it is washed to remove catalyst and then an antioxidant and other desired chemicals such as oils and fillers are added. The rubber cement is pumped to a coagulator (Step 6) where the rubber is precipitated in crumb form. Unreacted monomers and solvent are recovered by steam stripping. The stripped rubber cement slurry is sent to a washing and drying section (Step 7) where it is separated, washed, and then passed through an extruder for dewatering and drying. The dried rubber is baled and stored.^{11,13}

Emissions

The emission sources at an SB copolymer facility are typical of those common to chemical production facilities: process vents, open process equipment, equipment leaks, storage tanks and transfer operations and secondary emissions from the handling and disposal of wastes. Styrene may also be emitted during accidental or emergency releases.

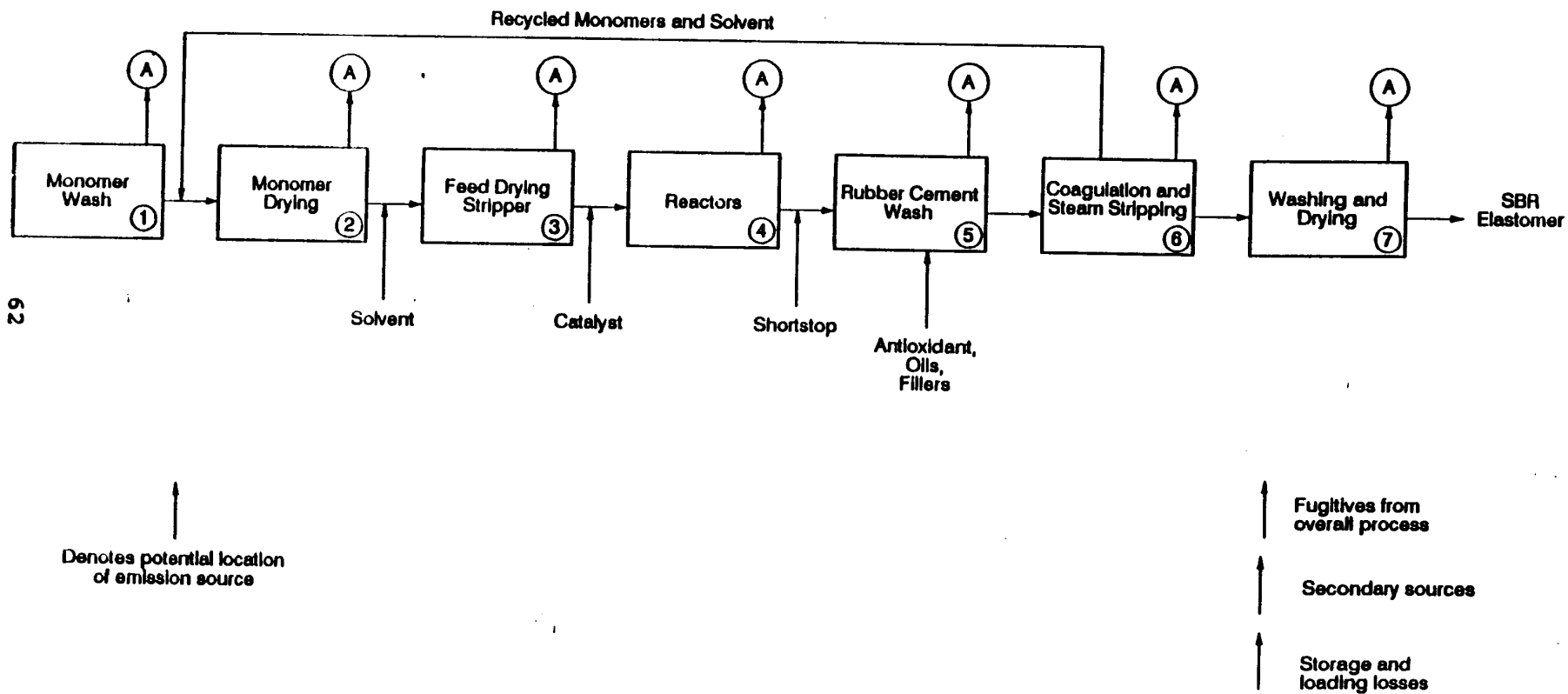

Figure 10. SBR Production by Solution Polymerization¹¹

Emissions from process vents and open equipment occur from reactors, recovery columns, blend and coagulation tanks, filter screens, dryers and other process vessels. They may occur continuously (from a continuous process) or intermittently (from a batch process). Polymerization reactors for both emulsion and solution processes are normally sealed using rupture discs, with venting to a flare during rare, extreme upset conditions. Most of the styrene emitted during the emulsion crumb process occurs by evaporation from open blend and coagulation tanks and from dryer vents. An estimated 78 percent of total VOC emissions (mostly styrene) from the emulsion crumb process are emitted during the copolymer drying steps.¹⁴ An emission factor for the drying step in SBR emulsion polymerization is given in Table 13. Emission data for other process sources are not available.¹⁵ In the SB latex production process, the latex is stripped of unreacted monomers and passed through shaker screens to remove large agglomerated solids. These screens are open to the atmosphere, but emissions are estimated to be very low. Concentrations of 25 ppm styrene (and 39 ppm butadiene) have been measured above the screens, but the air flow rate could not be determined.¹⁶

To control process vent emissions, the process streams can be routed to a flare or blowdown tank. Recovered styrene emissions from the vacuum distillation column are recycled with the reactor feed stream. Where feasible, open equipment may be enclosed.⁶

Sources of fugitive emissions are listed in Section 4. Also provided is a description of the procedure for estimating emissions and a table of control options and efficiencies.

At these facilities the major source of air emissions of styrene occurs from styrene transfer during the unloading of trucks, tank cars and barges and the filling of the monomer storage tanks. No SB copolymer facilities are known to have

installed control devices to reduce or capture these emissions.⁶ Losses of styrene from storage tanks also occur due to normal tank breathing processes. Uncontrolled emission factors for breathing and fugitive losses of styrene from storage tanks are presented in Table 13.¹⁵

STYRENE-ACRYLONITRILE PRODUCTION

Styrene-acrylonitrile copolymers are noncrystalline, linear resins. They are characterized by good hardness, rigidity, dimensional stability, high heat deflection temperatures, and chemical resistance.¹ Acrylonitrile provides the chemical resistance and heat stability, and styrene provides rigidity and processing ease. A diversity of SAN specialty grades, including UV-stabilized, antistat, barrier, and weatherable grades are available.¹⁷ The styrene content of SAN ranges from 65 to 85 percent.^{6,17,18}

The majority of SAN manufactured is used captively to produce acrylonitrile-butadiene-styrene resins. SAN also has a wide range of applications in the automotive, housewares, electronics, appliances, and packaging marketing areas. SAN is used in automotive trim, marine instruments, tractor components, coffee filter funnels, instrument panels on appliances and automobiles, boat hulls, swimming pool components, cassette parts, syringes, dentures, toothbrush handles, blender bowls, and vacuum cleaner parts. Most of the SAN sold in the United States is used for injection molding as a replacement for polystyrene.¹⁹

Only two companies produce SAN exclusively for sale on the market. These facilities and their annual capacities are listed in Table 14. SAN is also produced at all ABS facilities, as a step in the manufacture of ABS.⁵ Less than four percent of styrene production in the United States is used in the manufacture of SAN for direct sale.²⁰

TABLE 13. EMISSION FACTORS FOR STYRENE-BUTADIENE PRODUCTION

Industrial Process	Emission Source	Emission Rate		Control Status
		(Kg Styrene/ Mg Resin)	(Lb Styrene/ Ton Resin)	
SBR-emulsion	Drying	0.6	1.2	Uncontrolled
SBR-emulsion	Storage tank (fugitive)	0.4	0.8	Uncontrolled
SBR-emulsion/ solution	Storage tank (breathing)	0.02	0.04	Uncontrolled

Source: Reference 12.

TABLE 14. STYRENE-ACRYLONITRILE PRODUCTION FACILITIES

Company ^a	Location	Annual Capacity	
		(Mg/yr)	(MM lb/yr)
Dow	Midland, MI	31,751	70
Monsanto	Addyston, OH	<u>22,679</u>	<u>50</u>
	TOTAL	54,431 ^b	120

^aOnly those producers who manufacture SAN for sale on the merchant market are listed. All ABS resins producers have SAN resin production capacity.

^bNumbers do not total due to rounding.

NOTE: This listing is subject to change as market conditions change, facility ownership changes, plants are closed down, etc. The reader should verify the existence of particular facilities by consulting current listings and/or the plants themselves. The level of styrene emissions from any given facility is a function of variables such as capacity, throughput, and control measures, and should be determined through direct contact with plant personnel. These operating plants and locations were current as of January 1990.

Source: Reference 5.

Process Descriptions

SAN resins may be produced by emulsion, suspension, or continuous mass polymerization. The majority of SAN for captive use is produced using emulsion polymerization. SAN for sale in the marketplace is most often produced by mass polymerization.²¹

Emulsion Process--

SAN production by emulsion polymerization, shown in Figure 11, may be conducted in either a batch or a continuous mode.^{2,11,18} The batch process is more commonly used.²⁰ In both processes, styrene and acrylonitrile monomers are pumped into a monomer-makeup tank along with recovered acrylonitrile and chemical additives (Step 1). The monomer mix is fed into the polymerization reactor with emulsifier, initiator, chain-transfer agent and deionized water (Step 2). Copolymerization is carried out in the temperature range of 70-100°C (160-212°F) and proceeds to 90 to 98 percent conversion.²¹ The polymerization temperature may be reduced to as low as 38°C (100°F) if redox catalysis systems are used. After a suitable retention time in the reactor, the SAN copolymer melt (latex) is pumped to a steam stripper for recovery of unreacted monomers (Step 3). The copolymer latex may be used directly in the production of ABS resin, or it may be sent to a coagulation and flocculation section (Step 4). The polymer is filtered (Step 5) then washed, and dried (Step 6) to produce the solid SAN copolymer.² Dyes, antioxidants and other additives may be mechanically blended into the copolymer using extruders and rolling mills (Step 7). Polymer sheets from these operations are then pelletized and packaged.

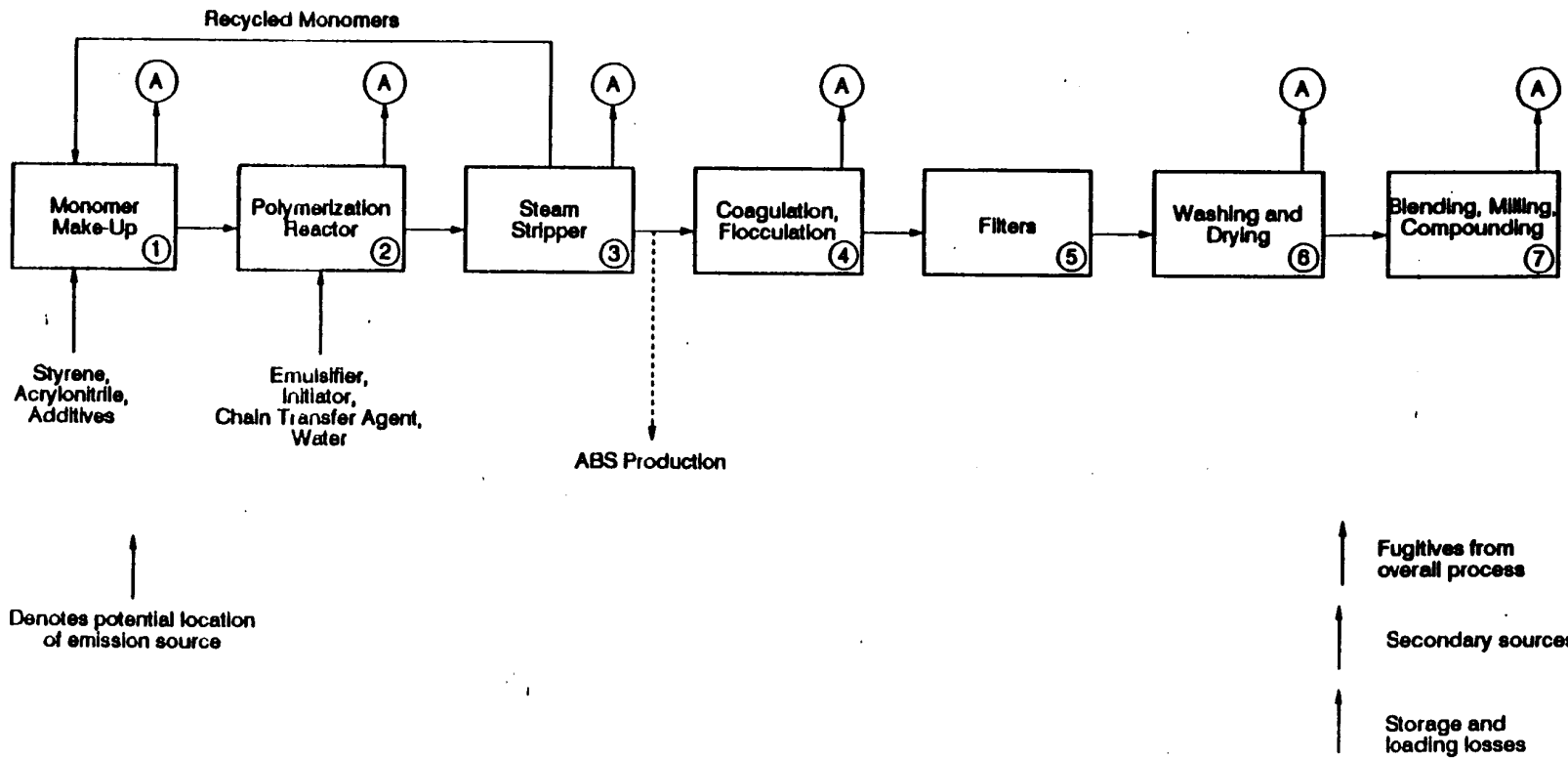

Figure 11. Production of SAN by Emulsion Polymerization²¹

Suspension Process--

SAN production by suspension polymerization may be conducted in either batch or continuous mode.^{2,11,18} A block flow diagram for the suspension process is given in Figure 12. Styrene and acrylonitrile monomers are fed into a pressure reactor and mechanically dispersed in water containing catalysts and suspending agents (Step 1). The water functions to remove heat and control particle size. Equal amounts of monomer and water are used.¹⁹ While suspended by agitation, the monomer droplets copolymerize forming insoluble beads of polymer. The temperature of the polymerization reactor ranges from 60-150°C (140-300°F). A monomer conversion of 95 percent is normally achieved. The polymer slurry is pumped to a centrifuge for washing and dewatering (Step 2). The polymer is sent to a flash tank and steam or vacuum stripper for recovery of unreacted monomers (Step 3). The solid and liquid phases of the polymer slurry are separated by centrifugation and/or filtration (Step 4). The solid phase is then dried in a rotary dryer (Step 5). The dried SAN is finished by mechanically blending in dyes, antioxidants and other additives. The polymer sheets are then pelletized and packaged (Step 6).^{7,8} This suspension process is simpler than the emulsion process as no coagulation and flocculation steps are required.

Continuous Mass Process--

The continuous mass process, shown in Figure 13, is a self-contained system that does not require emulsifiers, suspending agents, salts, or water. Solvents are used to control the viscosity. In Step one, styrene and acrylonitrile monomers are heated together with modifier-solvent and pumped continuously into the agitated polymerization reactor maintained at about 275 kPa (40 psia) and 100-200°C (212-390°F). Catalyst is added and reaction proceeds to 20 percent conversion. The polymer is

70

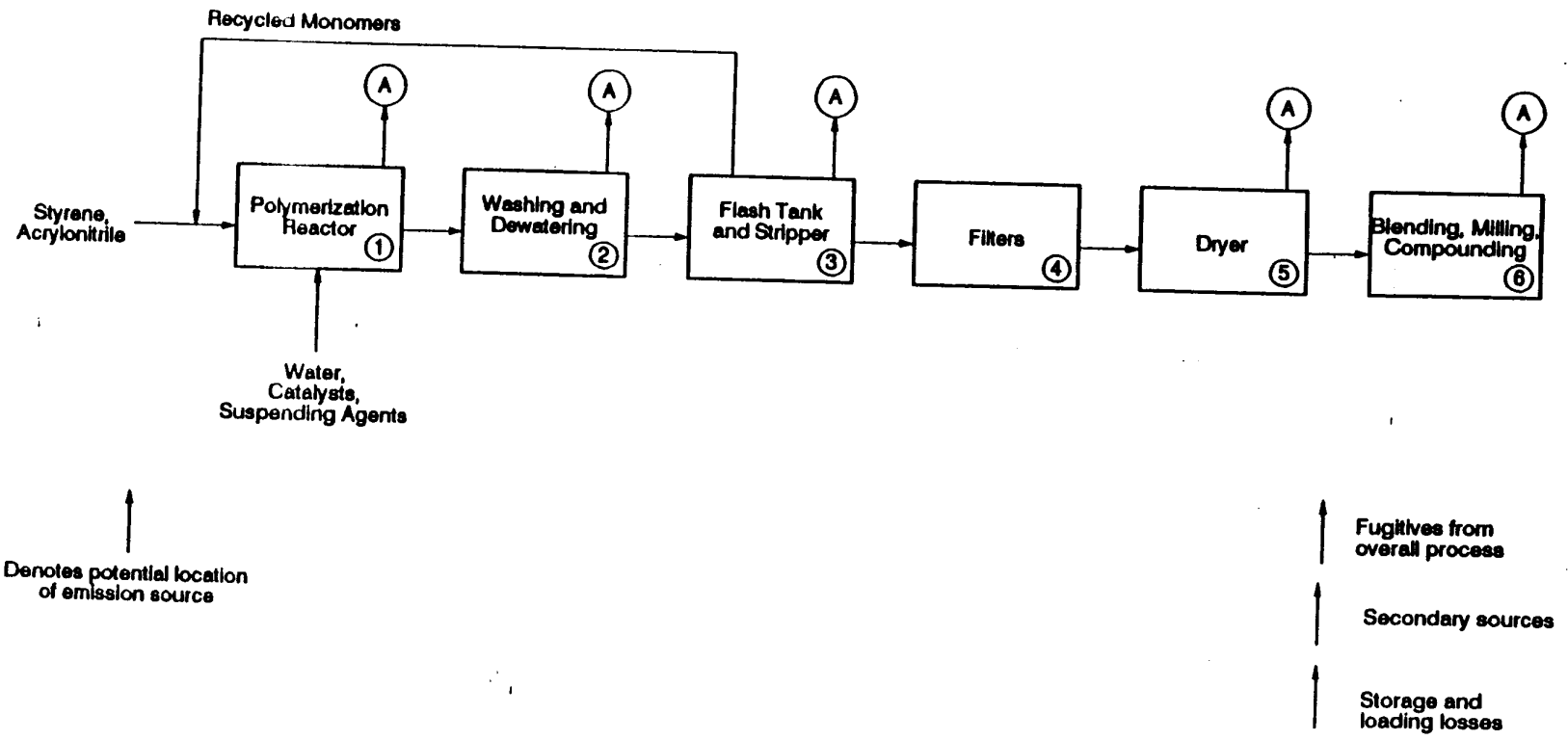

Figure 12. Production of SAN by Suspension Polymerization²¹

3204187R

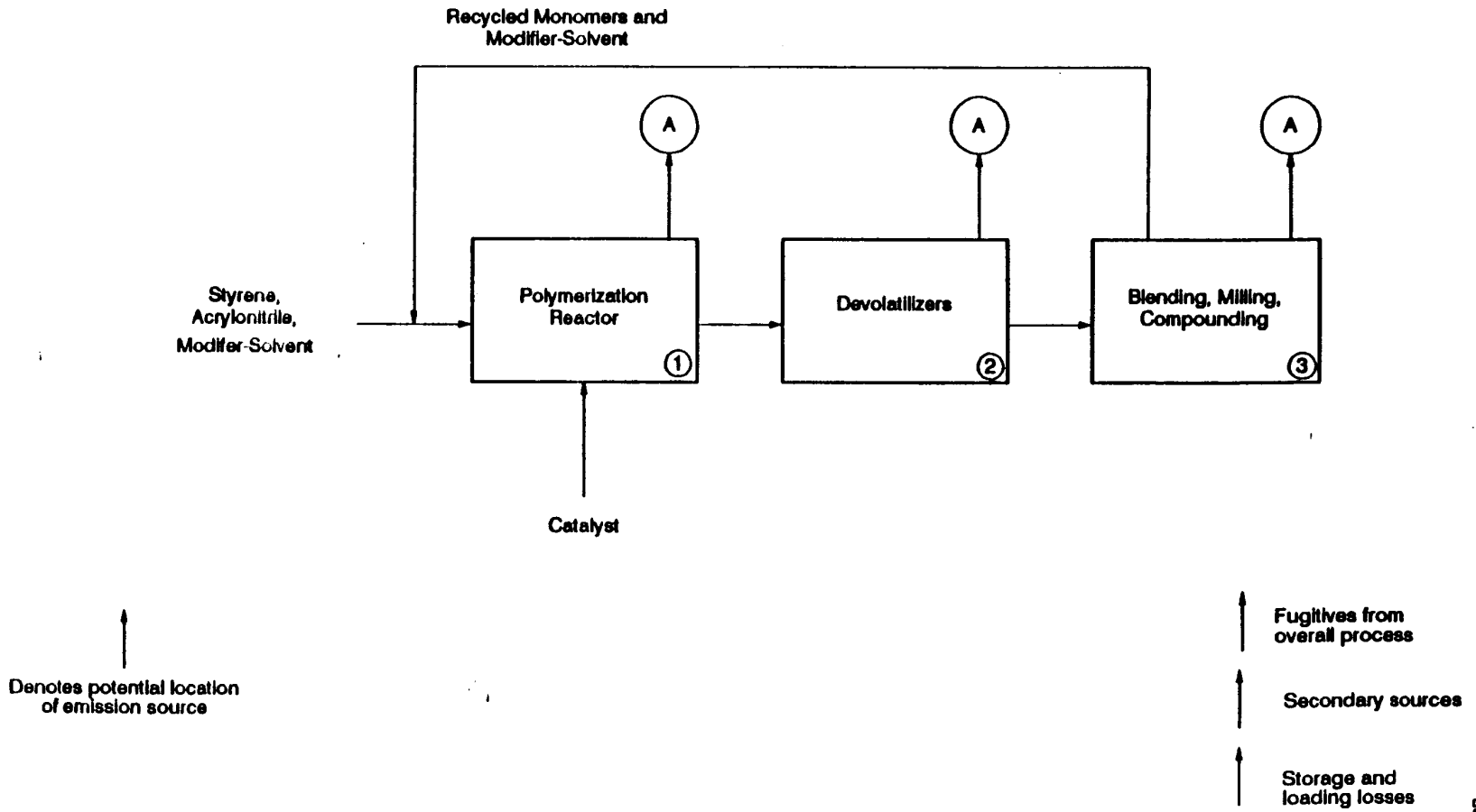

Figure 13. Production of SAN by Continuous Mass Polymerization²¹

passed through a series of devolatilizers to remove unreacted monomers and modifier-solvent (Step 2). Devolatilization occurs under vacuum at a temperature ranging from 120-260°C (248-500°F). Inerts, unreacted monomers and modifier-solvent are removed overhead from the devolatilizers. The overheads are the condensed and passed through a refrigerated styrene scrubber to recover monomers and modifier-solvent which are recycled to the feed tanks. The bottoms from the final devolatilizer are almost pure polymer melt. The polymer melt is pumped through an extruder, cooled and chopped into pellets (Step 3).^{2,11,18}

Emissions

Facilities manufacturing SAN emit styrene from process equipment vents, open process equipment, equipment leaks, storage tank vents, secondary sources, and transfer and handling operations. No emissions data for any of these sources are available.

Process equipment sources include monomer make-up tanks, polymerization reactors, monomer strippers, devolatilizers, coagulation/flocculation stages, dewatering/drying stages, and blending/compounding operations. The emissions will vary according to the type of polymerization process used and the exact monomer mix.

As described under styrene-butadiene copolymer production, process vent emissions may be controlled by routing the streams to a flare or blowdown. Currently, neither SAN facility has controls to capture or prevent styrene emissions from transfer operations.

ACRYLONITRILE-BUTADIENE-STYRENE COPOLYMER PRODUCTION

Acrylonitrile-butadiene-styrene resins are produced by grafting styrene-acrylonitrile copolymer onto a rubber and then

blending the grafted rubber with SAN.²³ Polybutadiene is normally used as the backbone or substrate rubber, but nitrile rubbers and SBR are also used. The resulting polymer has three phases: continuous matrix of SAN, dispersed phase of polybutadiene or other rubber, and boundary layer of SAN graft.²² The SAN grafted rubber provides adhesion between SAN and the rubber which would have been incompatible.

ABS possesses the useful properties of SAN, such as rigidity and resistance to chemicals and solvents, while the rubber additive imparts impact resistance.² ABS resins are produced with a wide range of properties that are tailored to specific applications. The differences in application are achieved by changing the relative concentrations of the three monomers and by using additives. Over 75 grades of ABS are available, including glass reinforced, UV-resistant, flame retardant, foamable, and electroplating grades.^{23,24,25} The resins are marketed in powder form or as natural and precolored pellets.²²

ABS resins are used to make plastic components for a variety of products such as automotive parts, pipes and fittings, appliances, telephones, business machines, toys and sporting goods. The major use for ABS is in the automotive industry, where the resins are injection molded to make interior trim components, consoles, instrument panel trim grills and wheel covers.

Currently ABS resins are produced by three companies at ten locations in eight States. These facilities and their production capacities are listed in Table 15. These ten facilities also produce SAN as a step in the manufacture of ABS. Industry-wide ABS capacity for 1990 is about 790,158 Mg/yr (1742 MM lbs).⁵ Manufacture of ABS and SAN resins consumes 9 percent of U. S. styrene production.⁶

TABLE 15. ACRYLONITRILE-BUTADIENE-STYRENE PRODUCTION FACILITIES

Company	Location	Annual Capacity	
		(Mg/yr)	(MM lb/yr)
Diamond Polymers	Akron, OH	9,979	22
Dow	Gales Ferry, CT	27,215	60
	Ironton, OH	36,287	80
	Midland, MI	68,039	150
	Torrance, CA	18,144	40
General Electric	Bay St. Louis, MS	95,254	210
	Ottawa, IL	136,078	300
	Washington, WV	158,757	350
Monsanto	Addyston, OH	145,150	320
	Muscataine, IA	<u>95,254</u>	<u>210</u>
TOTAL		790,158	1,742

NOTE: This listing is subject to change as market conditions change, facility ownership changes, plants are closed down, etc. The reader should verify the existence of particular facilities by consulting current listings and/or the plants themselves. The level of styrene emissions from any given facility is a function of variables such as capacity, throughput, and control measures, and should be determined through direct contact with plant personnel. These operating plants and locations were current as of January 1990.

Source: Reference 5.

Process Descriptions

ABS resins may be synthesized by emulsion, suspension, and continuous mass (bulk) polymerization. The majority of production is by batch emulsion. Specialized resins are produced by suspension polymerization. Emulsion and suspension polymerizations are based on an aqueous-phase reaction. In contrast, the continuous mass process, the newest technology, does not proceed in water. Therefore, dewatering and polymer drying are not required and wastewater treatment is minimized.²³

Emulsion Process--

A block diagram showing two routes by which ABS is produced using the emulsion process is presented in Figure 14. This process is referred to as the ABS/SAN process because SAN is prepared in a side step and mixed with graft ABS.

The emulsion process involves three distinct polymerizations:

- polymerization of butadiene to form polybutadiene;
- grafting of styrene and acrylonitrile monomers to the polybutadiene substrate; and
- copolymerization of styrene-acrylonitrile.

Butadiene monomer is converted to polybutadiene latex (Step 1) and then pumped into the ABS reactor with styrene, acrylonitrile, emulsifiers and initiators (Step 2). The styrene and acrylonitrile monomers are grafted to the polybutadiene latex substrate in either a batch or continuous process. Reaction conversion is 90 to 95 percent. Vapors from the reactor are usually vented to an acrylonitrile absorber. The absorber emissions are usually vented to the atmosphere or incinerated. The graft ABS is then transferred to a coagulator (Step 3). SAN

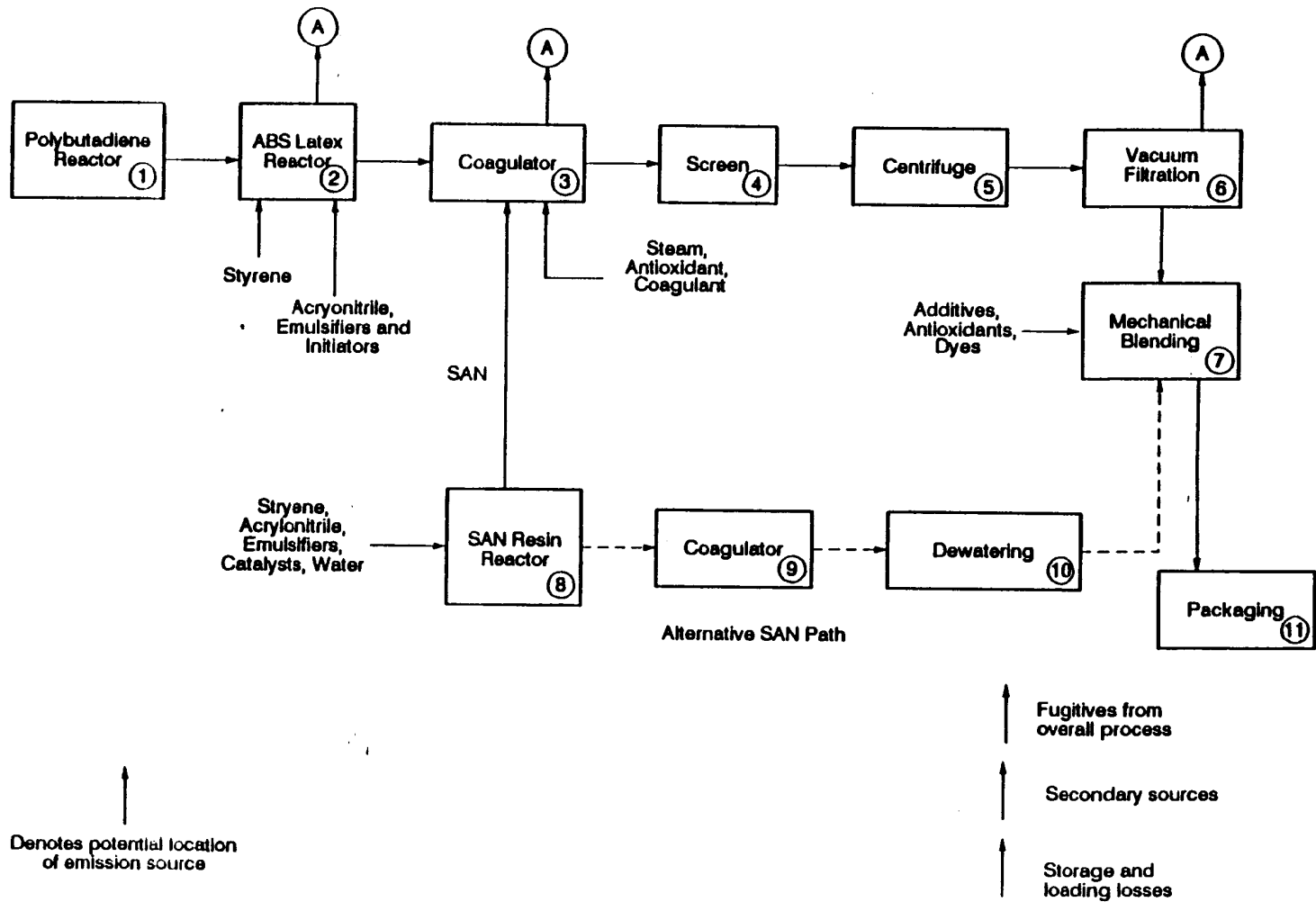

Figure 14. Production of ABS/SAN by Emulsion Polymerization¹¹

copolymer is prepared in a separate side step (Step 8) (see process descriptions under SAN copolymers in this section). The graft ABS and the SAN may be mixed together at either of two points in the emulsion process. The SAN latex may be added to the graft ABS latex in the ABS coagulator (Step 3). The agglomerated polymer is dewatered by screening (Step 4), centrifuging (Step 5), and vacuum filtration (Step 6). No drying step is required. However, some facilities employ a dryer in place of the centrifuge and vacuum filter. The ABS is sent to a finishing section where dyes, antioxidants, and other additives are mechanically blended in (Step 7). Alternatively, the SAN latex may be pumped into an SAN coagulator (Step 8) and sent to a dewatering section (Step 10) separately. The solid SAN is then mechanically mixed with solid graft ABS at the finishing stage (Step 7). The polymer sheets are cut into pellets and packaged (Step 11).^{2,11,18}

In a third route (not shown) SAN graft and styrene-acrylonitrile copolymerization occur in the same reaction vessel. The resulting ABS latex is coagulated, washed, filtered and dried.

Suspension Process--

A block flow diagram of the suspension ABS process is shown in Figure 15. This process begins with polybutadiene rubber which is so lightly cross linked that it is soluble in the acrylonitrile and styrene monomers. The polybutadiene is first dissolved in styrene and acrylonitrile monomers to produce a solution free of crosslinked rubber gels (Step 1). The solution is pumped into a prepolymerizer where a free-radical initiator is added along with chain-transfer agents in a prepolymerizer (Step 2). After 25 to 35 percent monomer conversion, the polymer syrup is transferred to a suspension reactor where it is dispersed in water by agitation (Step 3).

78

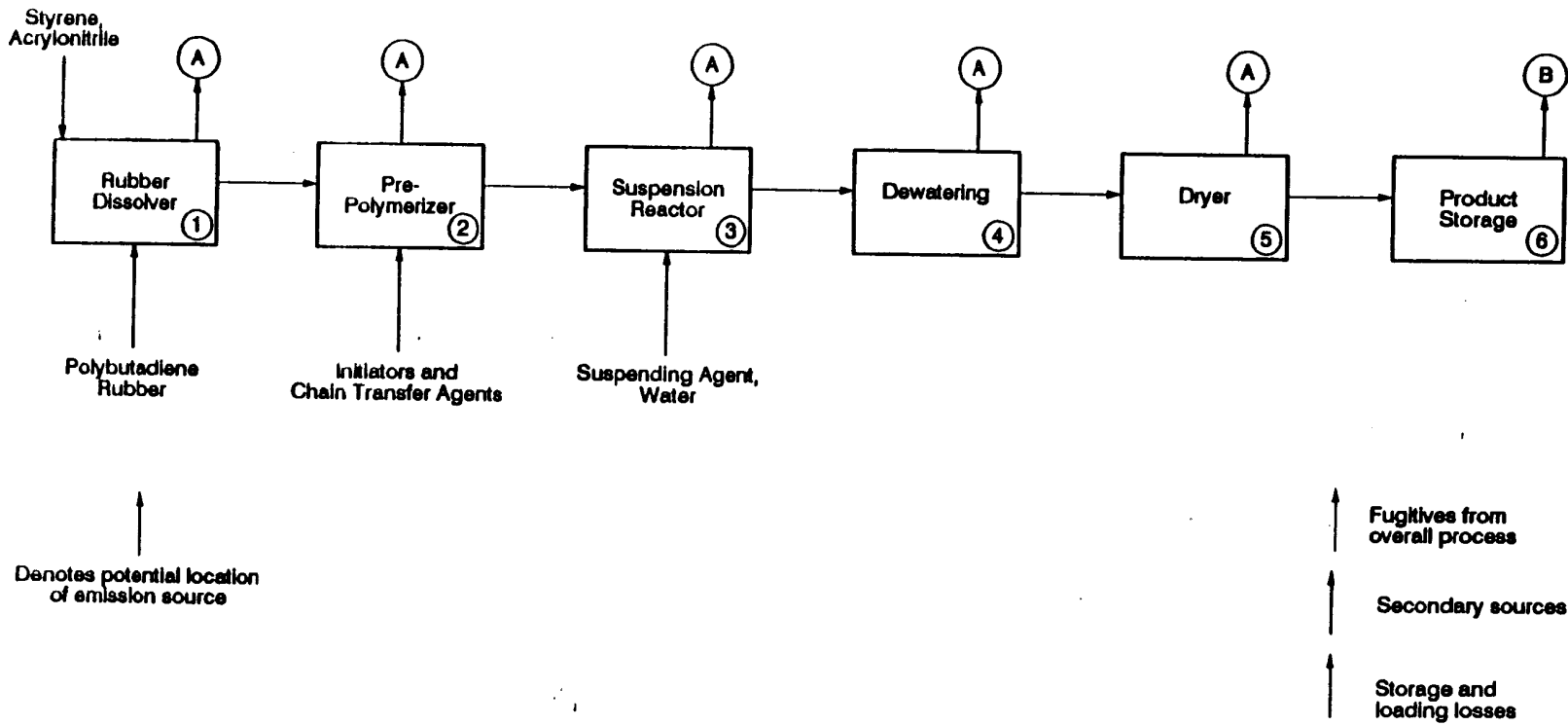

Figure 15. Production of ABS by Suspension Polymerization¹¹

3204184R

After achieving the desired monomer conversion, the products are transferred to a washing/dewatering system (Step 4), usually a continuous centrifuge. The polymer beads are then sent to a hot air dryer (Step 5). The dried finished beads are transferred to product storage (Step 6).^{2,11,18}

Continuous Mass Process--

A block flow diagram for the continuous mass ABS process is shown in Figure 16.¹⁹ Unlike emulsion and suspension polymerization, this polymerization process does not proceed in water. A lightly cross-linked, monomer-soluble form of polybutadiene is dissolved in styrene and acrylonitrile monomers, along with initiators and modifiers (Step 1). The mixed feed is pumped into a prepolymerizer, in which a conversion reaction causes the ABS rubber to precipitate out of solution (Step 2). When monomer conversion reaches about 30 percent, the resulting syrup is transferred to the bulk polymerizer where monomer conversion is continued to between 50 to 80 percent (Step 3). The polymer melt is sent to a devolatilizer (Step 4) where unreacted monomer is removed under vacuum. The monomer vapors are condensed and recycled to the prepolymerizer. The ABS polymer is then passed through an extruder, cooled in a water bath (Step 5), and chopped into pellets (Step 6).^{2,11,18}

Emissions

Information is available on acrylonitrile and butadiene emissions from 10 ABS production facilities. Although styrene emissions were not reported separately by any of the facilities, three facilities listed "other VOC" emission estimates, of which the major component is likely to be styrene. These VOC emissions were attributed to process vents from polymerization reactors, coagulation/washing steps, dewatering, intermediate process tanks, and compounding.²³ Significant styrene emissions result primarily from unloading styrene from tank trucks and barges and

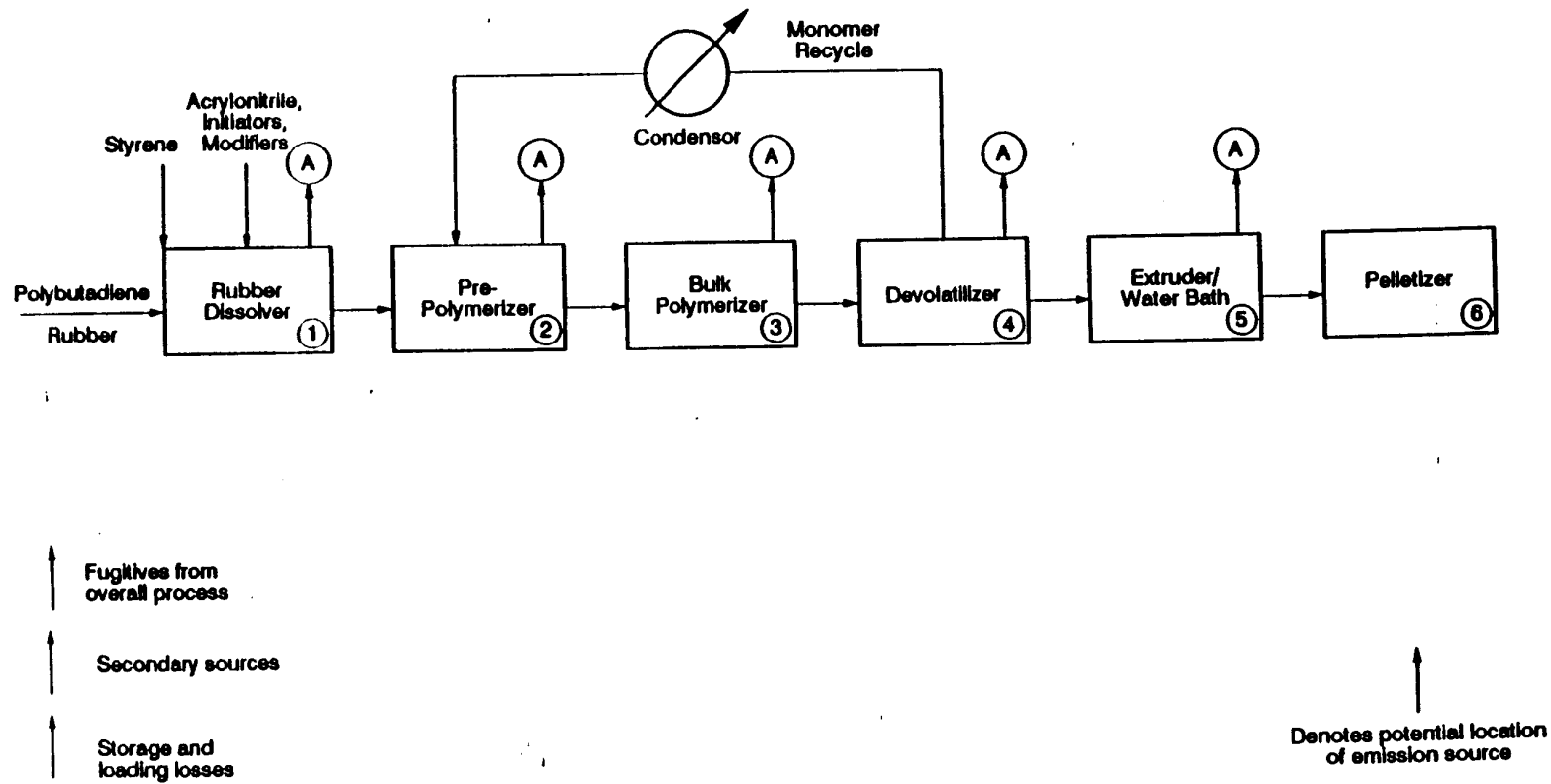

Figure 16. Production of ABS by Continuous Mass Polymerization¹¹

filling the storage tank.⁶ In addition, some emissions are possible from secondary sources and emergency and accidental releases. Insufficient information is available to develop emission factors for fugitives or process emission sources.

The emission points vary depending upon the type of polymerization process used. The emulsion process has the highest emissions while the continuous mass process has inherently low emissions. In addition, styrene emissions may vary from plant to plant depending on product mix.

Manufacturers of ABS resins have taken two basic approaches to control some of the AN process vents: high monomer conversion technology (HMCT) and thermal oxidation. These techniques would also control styrene emissions. The high monomer conversion is achieved using a second reactor the same size as the first reactor where conversion is increased to around 98 percent. The HMCT requires that the second reactor and an absorber be installed at the polymer filter step. Thermal oxidation is applicable to all types of ABS processes. In this approach emission vents are tied into one or more combustion devices. These devices may be parts of steam generators, incinerators or flares.²³

UNSATURATED POLYESTER RESIN PRODUCTION

Thermoset polyester resins are complex polymers resulting from the cross-linking reaction of a liquid unsaturated polyester with a vinyl type monomer, most often styrene. The unsaturated polyester is formed from the condensation reaction of an unsaturated dibasic acid or anhydride, a saturated dibasic acid or anhydride, and a polyfunctional alcohol. Table 16 lists the most common compounds used for each component of the polyester "backbone," along with the principal cross-linking monomer styrene. The chemical reactions that form both the unsaturated

TABLE 16. TYPICAL COMPONENTS USED TO FORM
UNSATURATED POLYESTER RESINS

Unsaturated Acids	Saturated Acids	Polyfunctional Alcohols	Cross-Linked Agent (Monomer)
Maleic anhydride Fumaric acid	Phthalic anhydride Isophthalic acid Adipic acid	Propylene glycol Ethylene glycol Diethylene glycol Dipropylene glycol Neopentyl glycol Pentaerythritol	Styrene

Source: Reference 27.

polyester and the cross-linked polyester resin are shown in Figure 17.²⁷

In order to be used in the fabrication of products, the liquid resin must be mixed with a catalyst to initiate polymerization into a solid thermoset. Catalyst concentrations generally range from 1 to 2 percent by original weight of resin; within certain limits, the higher the catalyst concentration, the faster the cross-linking reaction proceeds. Common catalysts are organic peroxides, typically methyl ethyl ketone peroxide or benzoyl peroxide. Resins may contain inhibitors, to avoid self curing during resin storage, and promoters, to allow polymerization to occur at lower temperatures.²⁷

Unsaturated polyester resins (UPR) are produced by 23 companies at 56 locations in the United States as shown in Table 17. Production capacity for these facilities was not found in the literature. Although styrene is not the only monomer that may be used as a cross-linking agent, it is the most common. In 1988, total UPR production in the United States was 768,852 Mg (1695 MM lbs).⁶ UPR is a thermoset resin used in construction (tubs and showers), marine and marine accessories (boats, boat accessories), casting (cultured marble and onyx), transportation (distributor caps, auto body parts), consumer goods (appliances), gel coatings, surface protective coatings, bonding/adhesives, electrical components, and business machines.

Process Description

Unsaturated polyester resins can be produced by a fusion or a solvent process. There is no published information on their relative capacities, however. In the fusion process, an inert gas (typically nitrogen) is used to remove water that is generated during the production process. The solvent process uses azeotropic distillation.⁴ Both of these are batch processes. The fusion process consists of the reacting

Reaction 1 - Unsaturated Polyester

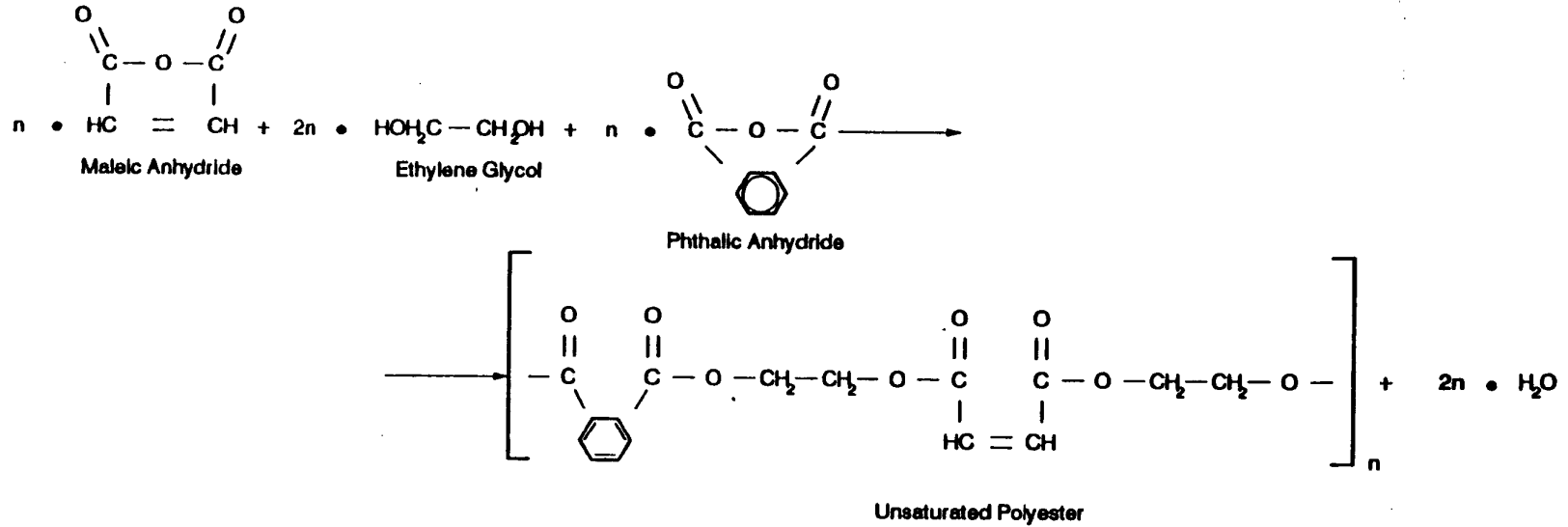

Reaction 2 - Polyester Resin

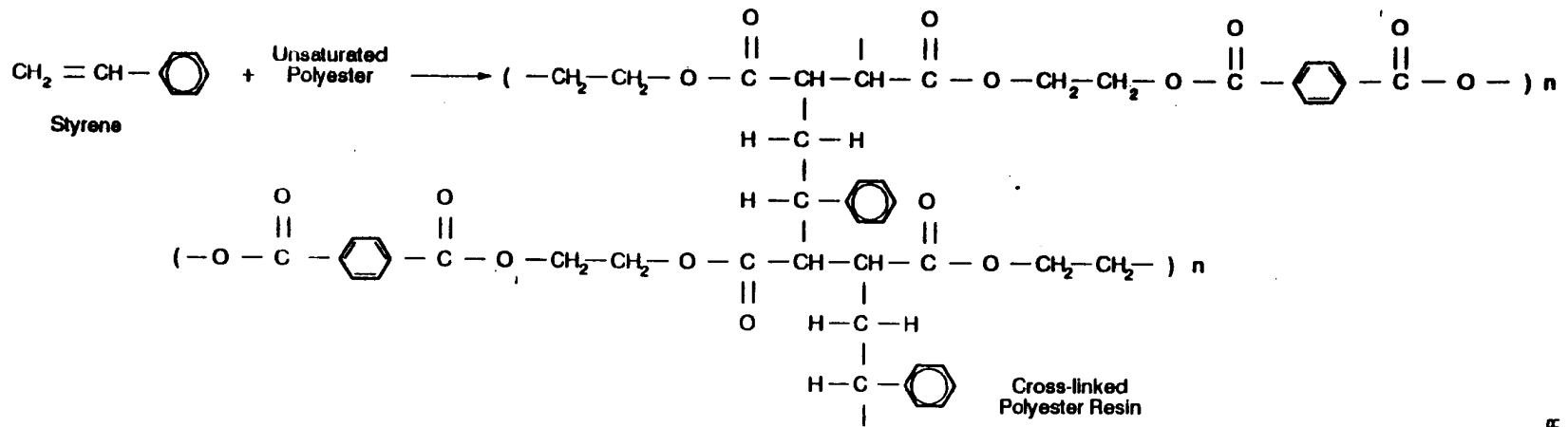

Figure 17. Typical Reaction for Unsaturated Polyester and Polyester Resin Formation²⁷

TABLE 17. PRODUCERS OF UNSATURATED POLYESTER RESINS

Facility	Location(s)
The Alpha Corporation	Collierville, TN Kathleen, FL Perris, CA
American Cyanamid Company	Wallingford, CT
Aristech Chemical Corporation	Bartow, FL Colton, CA Jacksonville, AR Neville Island, PA
Ashland Chemical Inc.	Ashtabula, OH Calumet City, IL Los Angeles, CA Philadelphia, PA Bartow, FL
Barton Chemical Corporation	Chicago, IL
BASF Corporation	Detroit, MI
Bayer USA Inc.	Houston, TX
BP America, Inc.	Covington, KY Hawthorne, CA
Cargill, Inc.	Atlanta, GA Parpentersville, IL Ennis, TX Forest Park, GA Lynwood, CA
Cook Composites	Bethlehem, PA North Kansas City, MO Catham, VA Marshall, TX Saukville, WI
Dow Chemical U.S.A.	Joliet, IL
Emhart Corporation	Middleton, MA
The P.D. George Company	St. Louis, MO
High J. - Resins Company	Long Beach, CA
ICI American Holdings, Inc. (The Gliden Company)	Columbus, GA Reading, PA
Insulating Materials Inc.	Schenectady, NY

TABLE 17. (Continued)

Facility	Location(s)
Interplastic Corporation	Minneapolis, MN Pryor, OK
The O'Brien Corporation	South Bend, IN
Owen's Corning Fiberglas Corp.	Anderson, SC Valparaiso, IN
Reichhold Chemicals, Inc.	Azusa, CA Bridgeville, PA Houston, TX Jacksonville, FL Morris, IL Oxnard, CA
Sherex Chemical Company	Lakeland, FL
Trinova Corporation	Auburn, ME
Valspar Corporation (McWhorter, Inc., subsidiary)	Chicago, IL Rochester, PA Baltimore, MD Carpenstersville, IL Kankakee, IL Los Angeles, CA Philadelphia, PA Portland, OR

NOTE: This listing is subject to change as market conditions change, facility ownership changes, plants are closed down, etc. The reader should verify the existence of particular facilities by consulting current listings and/or the plants themselves. These operating plants and locations were current as of January 1990.

Source: Reference 5.

(polyesterification) and thinning stages (Figure 18). During polyesterification, dibasic acids such as maleic and phthalic anhydrides, isophthalic acids, and glycols such as ethylene and propylene glycol are combined to form a soluble resin. This condensation reaction is carried out in an insulated stainless steel or glass-lined kettle. The mixture is then heated to about 200°C and held for 10 to 20 hours, and water (by-product) is continuously removed by bubbling an inert gas through the mixture.^{4,28} When the desired degree of condensation is reached, the product is cooled, blended with additives if necessary, and transferred to the thinning tank. In the thinning tank, styrene monomer is combined with the cooling unsaturated resin from the polyesterification tank (Step 2). The final product is then transferred to a storage tank (Step 3).

The solvent process is similar to the fusion process except that instead of bubbling an inert gas through the mixture to remove water, xylene is added. A xylene-water azeotrope is formed. The azeotrope enhances the separation of water vapor by-product. The xylene in the condensed azeotrope is separated from the water and is recycled using a decanter and two receivers.

Emissions

The following information is taken directly from a 1979 report prepared for the U. S. Environmental Protection Agency that estimated and ranked VOC emissions for the plastics industry. Data were gathered through literature surveys, calculations, site visits, and questionnaire responses.⁴ For UPR production (both the fusion and the solvent processes), one source of styrene emissions is the thinning tank vent (A). Overhead vapors from the thinning operation are usually controlled by a cooling-water condensor; otherwise they remain uncontrolled. The emission factor developed for the UPR thinning tank is shown in Table 18. The authors of Reference 4 estimate

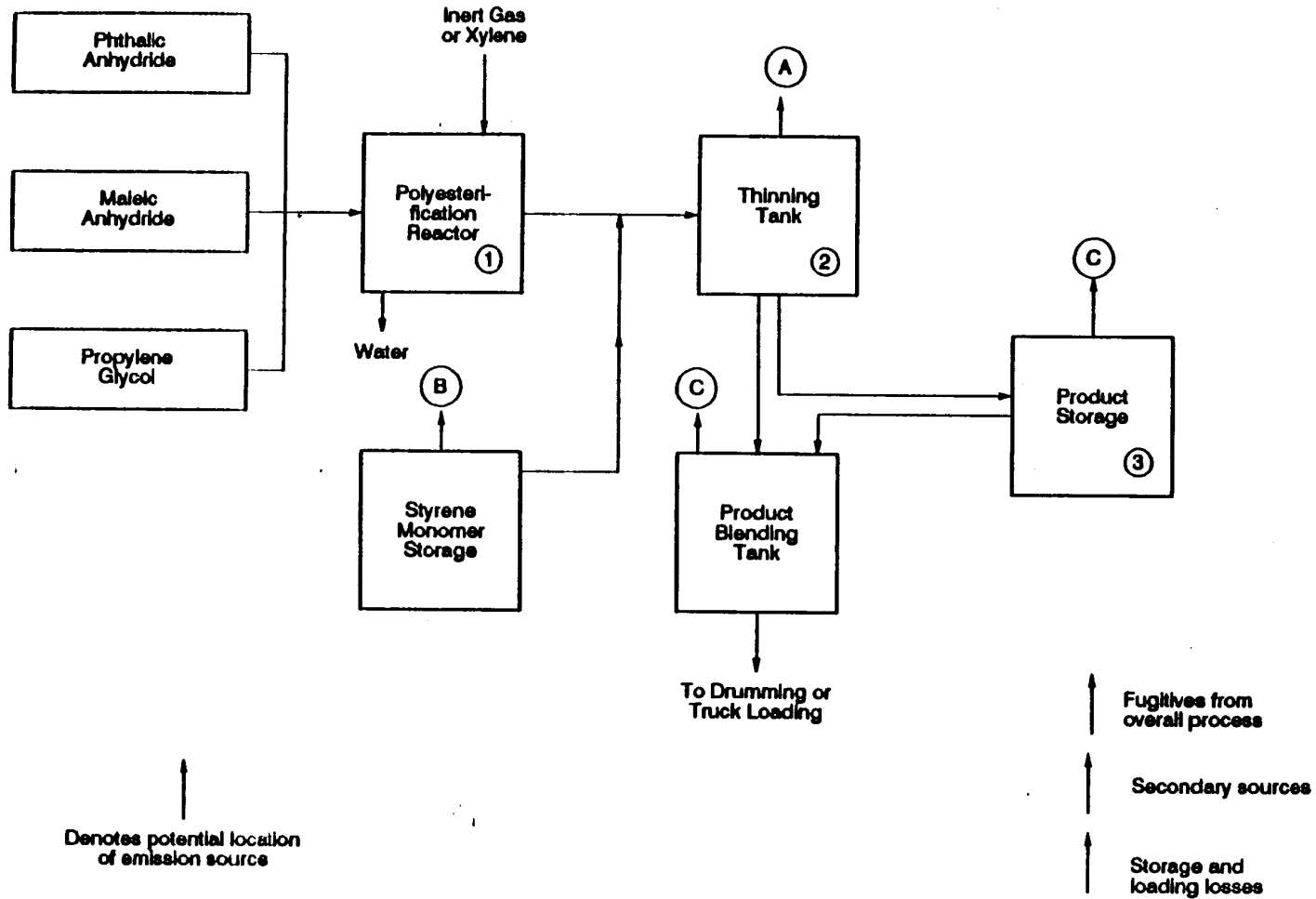

Figure 18. Unsaturated Polyester Resin Production

TABLE 18. EMISSION FACTORS FOR STYRENE
FROM UPR PRODUCTION

Emission Source	Estimated Emission Factor ^a	
	(Kg/Mg Resin)	(Lb/Ton Resin)
Thinning tank	0.08	0.16
Blending tank	0.05	0.10
Product storage	0.05	0.10
Monomer storage	0.02	0.04

^aThe emission factors are for fusion and solvent processes (while reactor is operating).

Source: References 4 and 28.

that the use of a refrigerated brine condensor on the thinning tank vent could reduce emissions by 80 percent. Industry experts indicate that this method is no longer practiced and that Thermal Oxidation is the preferred method today.²⁸

Also shown in Table 18 are styrene emission factors for UPR product storage (C) and styrene monomer storage (B). The emission factor shown for UPR product storage assumes that the tanks are equipped with fixed-roof tanks. Monomer storage tanks are also assumed to be equipped with fixed-roof tanks, with a 50 percent reduction in styrene emissions achievable with floating-roof tanks and/or refrigerated vent condensers.

MISCELLANEOUS STYRENE COPOLYMER PRODUCTION

In addition to the sources of styrene emissions previously discussed, styrene is also used in the production of miscellaneous products such as styrene-butadiene-vinylpyridine (SBV) latex, methyl methacrylate-butadiene-styrene (MBS) resins, and methyl methacrylate-acrylonitrile-butadiene-styrene (MABS) polymer. Table 19 summarizes the location of these facilities and their estimated production capacities.

Available details of the production processes will be provided, where known. Often these details are incomplete; therefore, readers should contact the facilities directly for the most accurate information. No information was found in the literature about styrene emissions from these facilities.

Styrene-Butadiene-Vinylpyridine Latex

No information on the production process or use of styrene-butadiene-vinylpyridine latex is available. As a copolymer, the production is likely to be similar to that of other copolymers.

TABLE 19. MISCELLANEOUS USES OF STYRENE IN CHEMICAL PRODUCTION

Company	Location	Product	Mode of Operation	1986 Design Capacity	
				(Mg/yr)	(MM lb/yr)
Ameripol Synpol	Port Neches, TX	Styrene-butadiene-vinylpyridine (SBV) Latex	Unknown	-- ^a	--
Borg-Warner Chemical Co.	Washington, WV	Methyl Methacrylate-butadiene-styrene (MBS) Resins ^b	Unknown	--	--
GenCorp	Mogadore, OH	SBV Latex	Unknown	--	--
Goodyear	Akron, OH	SBV Latex	Unknown	--	--
Goodyear	Calhoun, GA	SBV Latex	Unknown	--	--
Kaneka Texas Co.	Bayport, TX	MBS Resins	Batch	24,000 ^b	53
Metco America	Axis, AL	MBS Resins	Unknown	--	--
Rohm & Haas Co.	Louisville, KY	MBS Resins	Batch	--	--
Standard Oil Chemical Co.	Lima, OH	Methyl Methacrylate-acrylonitrile-butadiene-styrene (MABS) Polymer	Unknown	--	--

^a--" capacity not known.

^b Increased capacity due on-line by the end of 1987.

Source: Reference 11.

Methyl Methacrylate-Butadiene-Styrene Terpolymers

Methyl methacrylate-butadiene-styrene terpolymers are produced in resin form by four companies at four locations. This resin is used as an impact modifier in rigid polyvinyl chloride products for applications in packaging, building, and construction. Production of MBS terpolymers is achieved using an emulsion process in which methyl methacrylate and styrene are grafted onto a styrene-butadiene rubber. The product is a two-phase polymer.¹¹

Methyl Methacrylate-Acrylonitrile-Butadiene-Styrene Polymers

Methyl methacrylate-acrylonitrile-butadiene-styrene polymers are produced by Standard Oil Company under the trade name Barex®. The MABS copolymers are prepared by dissolving or dispersing polybutadiene rubber in a mixture of methyl methacrylate-acrylonitrile-styrene and butadiene monomer. The graft copolymerization is carried out by a bulk or a suspension process. The final polymer is two phase, with the continuous phase terpolymer of methyl methacrylate, acrylonitrile, and styrene grafted onto the dispersed polybutadiene phase.¹¹

These polymers are used in the plastics industry in applications requiring a tough, transparent, highly impact-resistant, and thermally formable material. Except for their transparency, the MABS polymers are similar to the opaque acrylonitrile-butadiene-styrene plastics. The primary function of methyl methacrylate is to match the refractive indices of the two phases, thereby imparting transparency.¹¹

REFERENCES FOR SECTION 5

1. Swett, R. M. Polystyrene. Modern Plastics Encyclopedia. 63:74-78. 1986-1987.
2. Kirk-Othmer Encyclopedia of Chemical Technology. 3rd Edition. Styrene Plastics. John Wiley and Sons. New York, New York. Vol. 1, pp. 427-441, Vol. 21, pp. 801-811. 1978.
3. Industrial Process Profiles for Environmental Use. Chapter 10 - The Plastics and Resins Production Industry. pp. 74-93, 465-518, 641-657.
4. Click, C. N. and D. K. Webber. Polymer Industry Ranking by VOC Emissions Reduction That Would Occur From New Source Performance Standards. Prepared for U. S. Environmental Protection Agency, Research Triangle Park, North Carolina. pp. 187-198, 227, 233-236. 1979.
5. SRI International. 1990 Directory of Chemical Producers - U.S.A. Menlo Park, California.
6. A. T. Kearney. Impact Analysis of the EPA Office of Drinking Water Proposal to Regulate Styrene. Styrene Information Research Center. 1989.
7. Chemical Product Synopsis. Polystyrene. April 1988.
8. U. S. Environmental Protection Agency. Polymer Manufacturing Industry - Background Information for Proposed Standards. Draft EIS. EPA-450/3-83-019a. U. S. Environmental Protection Agency. pp. 3-40 to 3-53. 1985.
9. U. S. Environmental Protection Agency. Guideline Series - Control of Volatile Organic Compound Emissions from Manufacture of High-Density Polyethylene, Polypropylene, and Polystyrene Resins. EPA-450/3-83-008. U. S. Environmental Protection Agency. pp. 2-18 to 2-25. 1983.
10. Letter from J. S. Matey, Chemical Manufacturers Association, to E. J. Vincent, U. S. Environmental Protection Agency. October 19, 1981.
11. Buchanan, S. K. Locating and Estimating Air Emissions from Sources of 1,3-Butadiene. EPA-450/2-89-021. U. S. Environmental Protection Agency, Research Triangle Park, North Carolina. pp. 44-45, 71-79. 1989.
12. Chi, C. T. et al. Source Assessment: Rubber Processing, State of the Art. EPA-600/2-78-004j. U. S. Environmental Protection Agency. pp. 12-21. 1978.

13. Chemical and Process Technology Encyclopedia. pp. 387-392. 1974.
14. U. S. Environmental Protection Agency. Guideline Series - Control of Volatile Organic Compound Emissions from Manufacture of Styrene-Butadiene Copolymers. U. S. Environmental Protection Agency, Research Triangle Park, North Carolina. Preliminary Draft. pp. 2-12. 1981.
15. Pope, A. A. et al. Toxic Air Pollutant Emission Factors - A Compilation for Selected Air Toxic Compounds and Sources. EPA-450/2-88-006. U. S. Environmental Protection Agency, Research Triangle Park, North Carolina. p. 4-216. 1988.
16. Rubber Products Styrene-Butadiene Rubber Manufacture. Emission Test Report General Tire and Rubber Company, Mogadore Chemical Plant, Mogadore, Ohio. U. S. Environmental Protection Agency, Research Triangle Park, North Carolina. EMB Report No. 79-RBM-4.
17. Shay, J. J. Styrene-Acrylonitrile. Modern Plastics Encyclopedia. 63:88-89.
18. Energy and Environmental Analysis, Inc. Source Category Survey for the Acrylonitrile Industry - Draft Report. Prepared for U. S. Environmental Protection Agency. pp. 3-10, 3-30 to 3-37. 1981.
19. Click, C. N. and D. O. Moore. Emission, Process and Control Technology Study of the ABS/SAN, Acrylic Fiber, and NBR Industries. Prepared for U. S. Environmental Protection Agency. Pullman Kellog. Houston, Texas. pp. 18, 33. 1979.
20. Chemical Profile: Styrene. Chemical Marketing Reporter. pp. 49, 50. August 14, 1989.
21. U. S. Environmental Protection Agency. Locating and Estimating Air Emissions From Sources of Acrylonitrile. EPA-450/4-84-007a. U. S. Environmental Protection Agency, Research Triangle Park, North Carolina. pp. 34-45. 1984.
22. Hensley, D.S. and C.A. Johnson. ABS and Related Multipolymers. Modern Plastics Encyclopedia. pp. 6-7. 1985-1986.
23. Memorandum from R. Burt and R. Howle, Radian Corporation, to L.B. Evans, EPA/Chemicals and Petroleum Branch, January 29, 1986. Estimates of Acrylonitrile, Butadiene, and Other VOC Emissions and Controls for ABS and NBR Facilities.

24. Lantz, J. M. ABS and Related Multipolymers. Modern Plastics Encyclopedia. pp. 6,8. 1986-1987.
25. Considine, D. M. ed. Acrylonitrile-Butadiene-Styrene Resins. Chemical and Process Technology Encyclopedia. McGraw-Hill Publishing Co., Los Angeles, California. pp. 32-34. 1974.
26. Rolston, J. A. Fiberglass Composite Materials and Fabrication Processes. Chemical Engineering, January 28: 96-110. 1980.
27. U. S. Environmental Protection Agency. Compilation of Air Pollutant Emission Factors. EPA-AP-42. U. S. Environmental Protection Agency, Research Triangle Park, North Carolina. pp. 4.12-1 to 4.12-3. September 1985.
28. Letter from Randazzo, C., SPI Composites Institute. Comments on draft "Locating and Estimating Air Emissions from Sources of Styrene" document. December 1990.

SECTION 6

EMISSIONS FROM THE USE OF STYRENE-CONTAINING MATERIALS

As discussed in Section 3, styrene-based resins are present in many materials, including packaging, appliances, building materials, furniture, electrical materials, housewares, rubber products, paints, adhesives, and automotive and recreational equipment parts. Sections 4 and 5 evaluate the potential for styrene emissions from styrene production and from the major intermediate styrene processors. Often these processors sell the resins as pellets, granules, powders, or liquids.¹ These resins may then be combined with colorants and fillers before they are transferred to the fabricator for manufacture of the final product. Alternately, the resin may be sold to a separate compounding facility for this treatment. The fabricators then extrude, inject, or spray styrene-based resins to make the final products.

To provide some idea of the prevalence of styrene-containing product manufacture, Table 20 presents an estimate of the total number of some of the styrenic resin fabricators in the United States. In addition to the resin producers listed in Sections 4 and 5, an additional 200 distributors and compounders sell styrenic resins to fabricators in the United States.¹

The production process descriptions and emissions data presented in this section cover some of the most common processes and products. Because of styrene's widespread use, all processes cannot be included here. Furthermore, emissions data were limited. Individuals are encouraged to examine the lists of final products in Section 3 to identify specific facilities to contact for emissions information.

This section also describes the results of industrial hygiene measurements of the release of styrene from the

TABLE 20. PREVALENCE OF STYRENIC RESIN FABRICATORS

Type of Facility	Number
UPR fabricators, cultured marble	1,600
UPR fabricators, marine	977
UPR compounders (bulk and sheet molding)	28
UPR fabricators, tubs, showers, spas, and hot tubs	197
Tire and inner tube manufacturers (SBR use)	56
Crystal and/or IPS	29
Polystyrene foam producers	237

Source: References 1 and 2.

thermodegradation of styrene-containing thermoplastics. In addition, three categories of styrene emission sources are described. The first is styrene emissions from an acrylonitrile-butadiene-styrene (ABS) compounding facility that receives ABS granules and adds colorants. The second category is styrene emissions from unsaturated polyester resins (UPR) use in different molding processes. Finally, the process descriptions for the manufacture of polystyrene foam products for drinking cups, loose fill, and other products are provided; no emissions data are available for this category.

THERMODEGRADATION OF STYRENE-CONTAINING MATERIALS

One less obvious source of styrene emissions is the thermodegradation of styrene-containing materials to form the final product. Because the processing of these materials typically involves high temperatures, varying amounts of occluded styrene monomer may be released. Styrene-containing thermoplastics are extruded or molded (by injection, compression, or blowing) at temperatures that range from 150 to 320°C. The following information on the release of styrene monomer during the processing of PS, impact (IPS), ABS, and SAN is based on industrial hygiene investigations conducted in Sweden and Finland.^{3,4}

In general, the thermostability of these materials is dependent on their molecular weight, mode of polymerization, and composition.⁴ Table 21 shows the range of styrene monomer released during the thermooxidative degradation of styrene-containing materials. The temperatures used and the oxygen content during combustion were intended to represent those encountered in industrial process situations. For PS, typical processing temperatures are 150 to 280°C for extrusion and injection molding and 190 to 235°C for blow molding.⁴

TABLE 21. STYRENE EMITTED FROM THERMOOXIDATIVE DEGRADATION
($\mu\text{g/g}$, lb/ton)^a

Temperature (°C)	Polystyrene	Impact Polystyrene	Acrylonitrile- Butadiene-Styrene	Styrene- Acrylonitrile
197	-- ^b	--	7800, 15.6 (68) ^c	--
200	Trace	--	--	--
208	--	--	2300, 4.6 (32)	--
218	--	--	--	2700, 5.4 (32)
224	--	310, 0.62 (3.4)	--	--
240	520, 1.04 (8.0)	--	--	--
250	740, 1.48 (7.0)	280, 0.56 (3.8)	--	--

^aUncontrolled emissions.

^b"--" Not measured.

^cStyrene yield is given in parenthesis as the percentage of total loss in weight.

Source: References 3 and 4.

Polystyrene is the most thermostable of the styrene-containing materials studied, and is considered stable during commercial molding and extruding at temperatures below 275°C.⁴

ACRYLONITRILE-BUTADIENE-STYRENE COMPOUNDING

The following material was provided by a State air pollution control office following source testing of an ABS compounding facility.⁵ Uncontrolled styrene emissions for this facility are presented under two different scenarios and the facility's original control system, a water spray scrubber, was evaluated for its effectiveness in reducing styrene emissions. The facility operators and State representatives then installed and tested an interim control measure of two packed columns in series in an effort to temporarily reduce styrene emissions while designing a permanent control system. Once installed, the permanent control system was found to be 99.5 percent effective in reducing total styrene emissions. The applicability of this information to other facilities is not known, nor is there any information on the number or location of similar facilities.

Process Description

The ABS compounding facility receives granulated ABS resin, mixes the resin with dyes and additives, and extrudes the final product (Step 1) into pellets for shipment (Figure 19). The plant operates six extruders; all of the extruder vacuum vents are pumped to one water ring vacuum pump (Step 2). All die vents are also pumped to a common vent and a common blower. The gaseous components are pulled into the vent system, while the water is discharged to the oil-water separation sump (Step 3). The discharge from the oil-water separation sump (Step 4) is then sent through a basket strainer and baffled to separate the oil from the water. The oil is hand skimmed and the water is sent to a rotating biological contactor (RBC) for biological treatment.

101

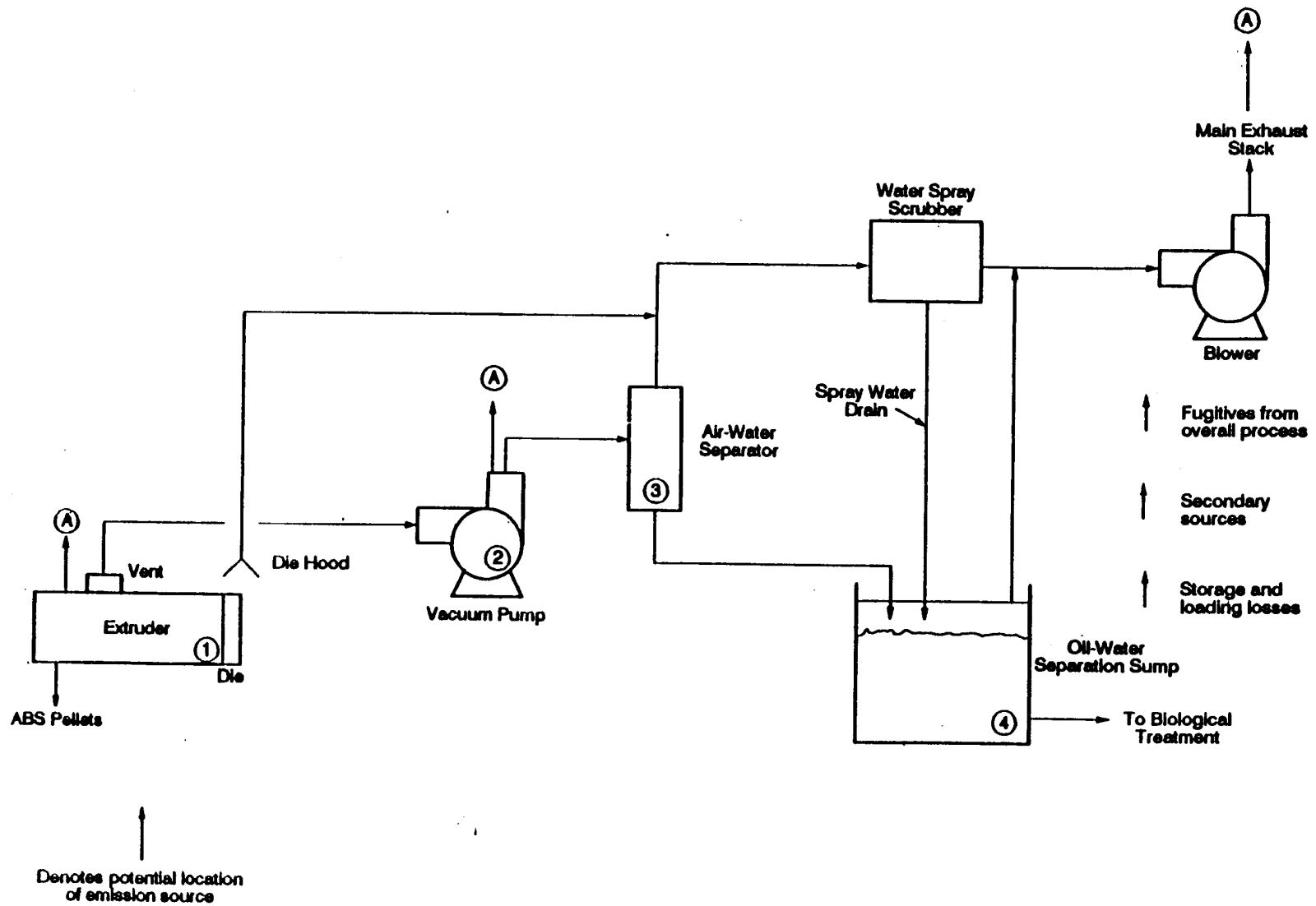

Figure 19. Original Vacuum and Vent System at an ABS Compounding Facility

The RBC sump and the outlet from the RBC are also piped into the die vent system.

Emission Measurements

The emissions from the die and vacuum pump streams were tested under a variety of control situations and are discussed below. In addition, styrene emissions were monitored to compare the emissions when the oil-water separation tank was enclosed and when it was open. The emissions were measured by gas chromatograph (GC) analyses and delta nonaqueous volatile (NAV) mass balance.

The extruder vacuum pump and die vent emissions were tested under four scenarios: uncontrolled with the oil-water separation tank open and enclosed, and controlled with a water spray scrubber with the oil-water separation tank open and enclosed. The vacuum pump discharge from the separator was also disconnected from the main stack to measure its emissions separately. Gas chromatograph styrene measurements were also taken around the oil-water separation sump.

Of the total emissions, the majority were from the vacuum pump discharge, with the remainder coming from the die vent. Stack emissions increased 20 percent when the oil-water separation sump was enclosed due to the reduction in fugitive losses. The results showed that the water spray scrubber was only 25 percent efficient in reducing styrene emissions, and in one measurement the controlled emissions were actually higher than uncontrolled emissions. Attempts to reduce vacuum pump emissions with a water spray in the outlet line were only 12 percent effective in overall emission reduction.

Emission estimates derived from GC analysis were then compared with estimates from NAV. The NAV is a mass balance estimate determined by monitoring resin content of the ABS resin,

pellets produced, vent oil sludge, and vacuum pump discharge water. In general, GC and NAV were found to agree within 21 percent.

Because the water spray scrubber does not adequately control styrene emissions, design of a better system was proposed. In the interim, two packed columns in series vented to a temporary carbon adsorption system were installed. The water/gas mixture discharged from the vacuum pump was first sent to an air-water separator, and the air leaving the separator was scrubbed in two columns. Water was fed to the columns from a recirculation tank. A total of 40 gallons per minute (gpm) were circulated through each column. About 6 gpm was drained from the recirculation tank for treatment in the RBC. The air leaving the second column was heated to raise the relative humidity above 50 percent and sent to a Calgon unit for carbon adsorption of the styrene. After passing through the carbon adsorption bed, the vacuum pump air stream combined with the die vent stream. This air stream then passed through the water spray scrubber system. Test results showed a total styrene emission reduction from the vacuum pump exhaust and die vent of 96.4 percent. Table 22 presents the emission factors developed from these data.

Permanent VOC controls were installed on this ABS compounding facility at a later date (Figure 20). The air from the air-water separator (about 200 standard cubic feet per minute (scfm)) is scrubbed in two columns. The outlet of the second scrubber passes through a heat exchanger. The air then passes through two small carbon beds (2,000 pounds each) and the outlet of the second bed is joined with the outlet of the die vent system blower. This air then passes through two large carbon beds (4,000 lbs each). Follow-up source testing indicated that emissions were reduced by more than 99.5 percent for total reactive organic compounds. Table 23 presents the emissions information for styrene at the outlet of the first large carbon

TABLE 22. SUMMARY OF SOURCE TESTING DATA FOR AN ABS
COMPOUNDING FACILITY UNCONTROLLED AND WITH TEMPORARY CONTROLS

Emission source	Control device	Data basis (NAV or GC) ^a	Emission factor (lbs sty/10 ³ lbs product or Kg sty/Mg product)	Comments
Extruder vacuum pump and die vent	water scrubber	GC	1.196	Normal process operation, oil-H ₂ O separator tank enclosed, 6 lines running (max. production rate)
Same as above	none	GC	1.676	Same as above
Same as above	water scrubber	GC	1.033	Normal operation, oil-H ₂ O separator tank open, higher fugitives, less process emissions
Same as above	none	GC	1.366	Same as above
Extruder vacuum pump	water scrubber	GC	1.129	Vacuum pump discharge measured separately from die vent
Same as above	none	GC	1.113	Same as above
Die vent	water scrubber	GC	0.013	Same as above
Same as above	none	GC	0.013	Same as above
Extruder vacuum pump and die vent	water scrubber	NAV	1.420	Normal operation, 6 lines running, oil-H ₂ O separator tank enclosed
Same as above	none	NAV	1.790	Same as above
Same as above	water scrubber	NAV	1.175	Normal operation but discharges measured separately, emission factor represents combined emissions
Same as above	none	NAV	1.307	Same as above
Extruder vacuum pump	scrubber/carbon adsorption	GC	0.006	Measured at carbon adsorption outlet, oil-H ₂ O pump separator enclosed

(continued)

TABLE 22. (Continued)

Emission source	Control device	Data basis (NAV or GC) ^a	Emission factor (lbs sty/10 ³ lbs product or Kg sty/Mg product)	Comments
Extruder vacuum pump and die vent	scrubber/carbon adsorption	GC	0.042	Main plant exhaust after control, oil-H ₂ O separator enclosed, vacuum pumps scrubber and adsorber controlled, die vents scrubber controlled
Extruder vacuum pump	none	GC	1.291	Uncontrolled vacuum pump emissions measured prior to scrubber
Same as above	scrubber	GC	0.859	Emissions measured after scrubbers and prior to carbon adsorption

^aNAV = nonaqueous volatile (mass balance of residual hydrocarbons in the resin, pellets, vent oil and wastewater).
 GC = Gas Chromatograph Analysis

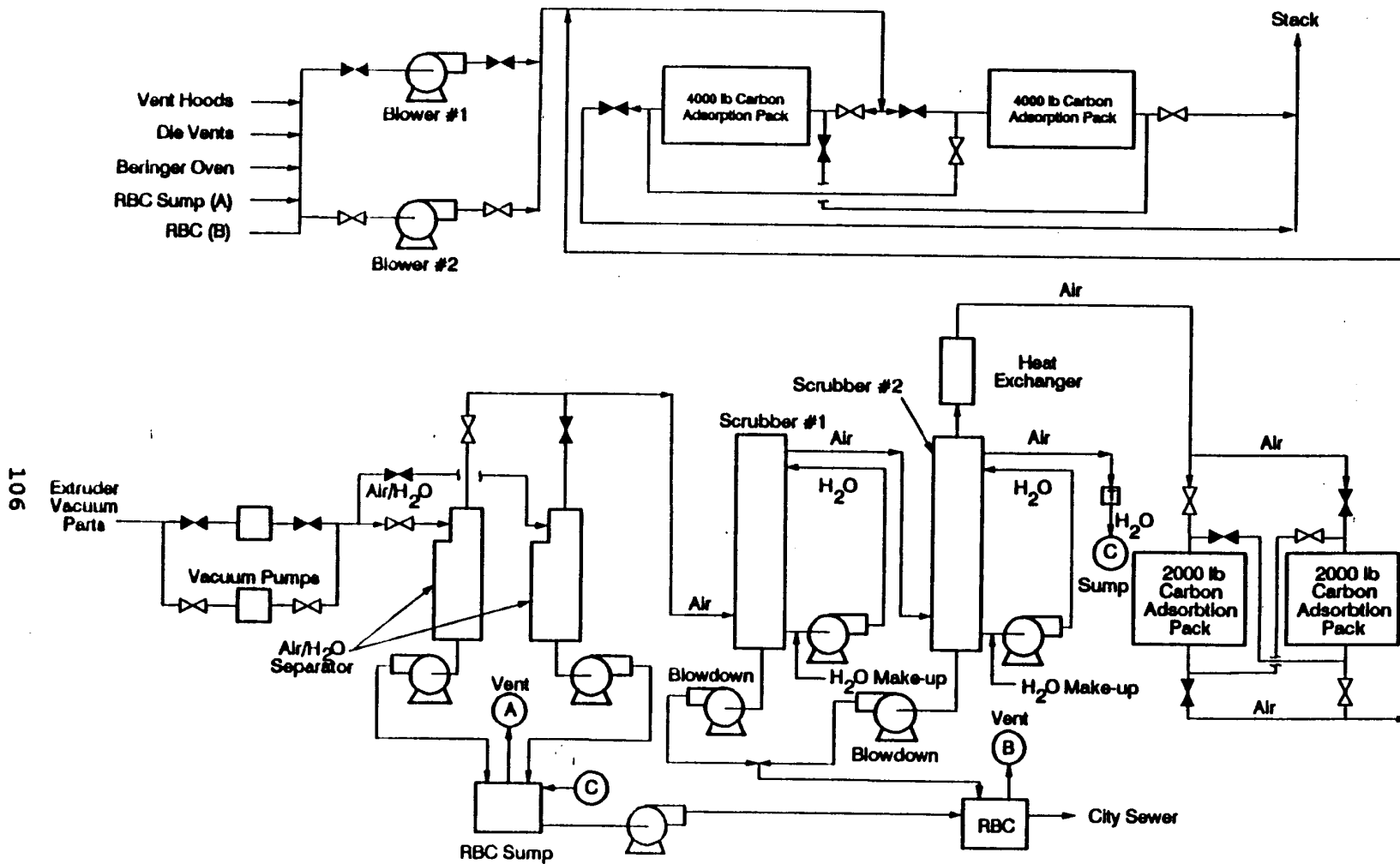

Figure 20. Permanent VOC Controls at an ABS Compounding Facility

TABLE 23. SUMMARY OF ABS COMPOUNDING FACILITY SOURCE TEST DATA AFTER INSTALLATION OF PERMANENT CONTROLS^a

Emission Source	Styrene Emission Factor ^b	Comments
Outlet of first large carbon bed	0.0012	Six lines running (max. production rate)
Outlet of first large carbon bed	0.0017	Five lines running
Vacuum pump outlet	1.5157	Six lines running
Vacuum pump outlet	1.6507	Five lines running
Outlet of second small carbon bed	0.0012	Six lines running after change of small carbon bed
Outlet of first small carbon bed	0.0017	Five lines running after change of small carbon bed
Outlet of second small carbon bed	0.0017	Five lines running after change of small carbon bed

^aMeasured by gas chromatograph.

^blbs/10³ lb product or kg/Mg product.

bed (a worst case scenario if operating on only one bed), and at the outlet of the second large carbon bed.

UNSATURATED POLYESTER RESIN USE

Styrene-containing UPR is used in the manufacture of boats, vehicle components, bowling balls, bathroom fixtures, gasoline storage tanks and other products.

Unsaturated polyester resins can be used in reinforced or non-reinforced applications. Eighty percent of UPR is reinforced, usually with glass fibers, and extended with various inorganic filler materials such as calcium carbonate, talc, mica or small glass spheres.^{6,7} These composite materials are often referred to as fiberglass reinforced plastic (FRP), or simply fiberglass.* The Society of the Plastics Industry designates these materials as "reinforced plastic/composites" (RP/C). Also, advanced reinforced plastic products are now formulated with fibers other than glass, such as carbon, aramid and aramid/carbon hybrids.⁷ Reinforced UPR is used to make boats and marine accessories, tub and shower stalls, transportation components and recreational vehicle components.⁶ Nonreinforced UPR is used in casting processes to make simulated marble products, cast furniture parts, buttons, and bowling balls.

Molding processes are either closed or open. Closed molding techniques are compression, injection, pultrusion, continuous lamination, marble casting, bag molding, and resin transfer. Open molding processes are hand layup, filament winding, and spray layup. Selection of closed or open molding depends on the size and volume of the product to be manufactured. Open molding

*As used in this report, "fiberglass" means glass fibers or fiberglass reinforced plastic. The term does not necessarily mean "Fiberglas™," trademark of Owens/Corning Fiberglas Corporation, Toledo, Ohio.

is used for large parts such as boats and recreational vehicle structures. Open molding processes of spray layup and hand layup offer advantages for firms that produce a limited number of units for each mold, require rapid startup, and operate with restricted capital for tooling. Because of limited production and/or unique designs, many fabricators will continue to rely on open mold fabrication.

In descending order of resin use, the UPR molding processes are:⁷

- Spray layup (sprayup);
- Hand layup;
- Continuous lamination;
- Press molding;
- Marble casting;
- Pultrusion;
- Filament winding;
- Resin transfer molding; and
- Bag molding.

Process descriptions for these molding processes are given below.

Open Molding

Most open mold fabricators use similar processes to produce products with varying composition, sizes, and shapes. For products with a smooth, durable surface, a smooth and highly polished mold is required. For many products, a catalyzed gel coat is applied as the initial step. The resins are generally either hand rolled or sprayed into the fiberglass reinforcement. Some hand rolling is essential even when the resin is sprayed, for removing voids and ensuring proper compaction of resin and reinforcing material.

Most open mold fabrication facilities consist of one or more open production areas. In these open areas, a large number of exhaust fan outlets are provided. Emissions can be reduced by

using airless spray guns, spray booths for gel coating and resin application, isolated work bay operations, and air filtration.

Spray Layup--

In UPR spray layup, the mold defines the shape of the outer surface, and the mold itself is usually made of reinforced plastic. The mold is first coated with a wax to ensure removal after curing. A layer of gel coat is then sprayed on to the mold to form the outermost surface of the products. Gel coats are highly pigmented unsaturated polyester resins that provide a smooth, colored surface that gives the appearance of a painted part.⁸ The gel coat is allowed to cure for several hours but remains tacky so subsequent resin layers adhere better. The polyester resin is applied with a spray gun that has a glass chopper attachment. This allows simultaneous spraying of resin and chopped glass onto the mold. The spray gun has separate resin and catalyst streams which mix as they exit the gun. Air spray guns require a large volume of air flow at high pressures. This provides good control over spray patterns; however, this type of spraying contributes to excessive fogging, overspray, and bounce back, resulting in increased emissions and material loss. To reduce styrene emissions, air-assisted airless spray guns can be used to apply gel coats and resins. Because high pressure is not needed at the nozzle, air-assisted airless spraying results in lower emissions and less material loss. Unsaturated polyester resins designed for use in spray layup are promoted for cure at room temperature and usually are catalyzed with a liquid peroxide such as methyl ethyl ketone peroxide (MEKP).⁹

Hand Layup--

Hand layup involves the same initial steps (up through application of the gel coat) as used in spray layup. Following gel coat application, alternate layers of catalyzed polyester resin and reinforcement material are applied. The ratio of resin

to glass is usually 60 to 40 by weight, but varies by product. Each reinforcement layer is "wetted out" with resin, and then rolled out to remove air pockets. The process continues until the desired thickness is achieved. Hand layup is also a room temperature curing process.

Filament Winding--

Filament winding, shown in Figure 21, is the process of laying a band of resin impregnated fibers onto a rotating mandrel surface in a precise geometric pattern, and curing them to form the product. This is an efficient method of producing cylindrical parts with optimum strength characteristics suited to the specific design and application. Glass fiber is most often used for the filament, but aramid, graphite, and sometimes boron and various metal wires may be used. The filament can be wetted during fabrication, or previously impregnated filament ("prepreg") can be used. The three most common winding patterns are circumferential, helical, and polar winding. The various winding patterns can be used alone or in combination to achieve the desired strength and shape characteristics. Mandrels are made of a wide variety of materials and, in some applications, remain inside the finished product as a liner or core. Example products are storage tanks, fuselages, wind turbine and helicopter blades, and tubing and pipe.⁷

Closed Molding

Closed molding systems reduce styrene emissions by eliminating the requirement for atomization of the resin. The most common closed molding processes are press molding, marble casting, pultrusion, continuous lamination, resin transfer molding, and bag molding. Of these, the two largest categories are press molding and marble casting.

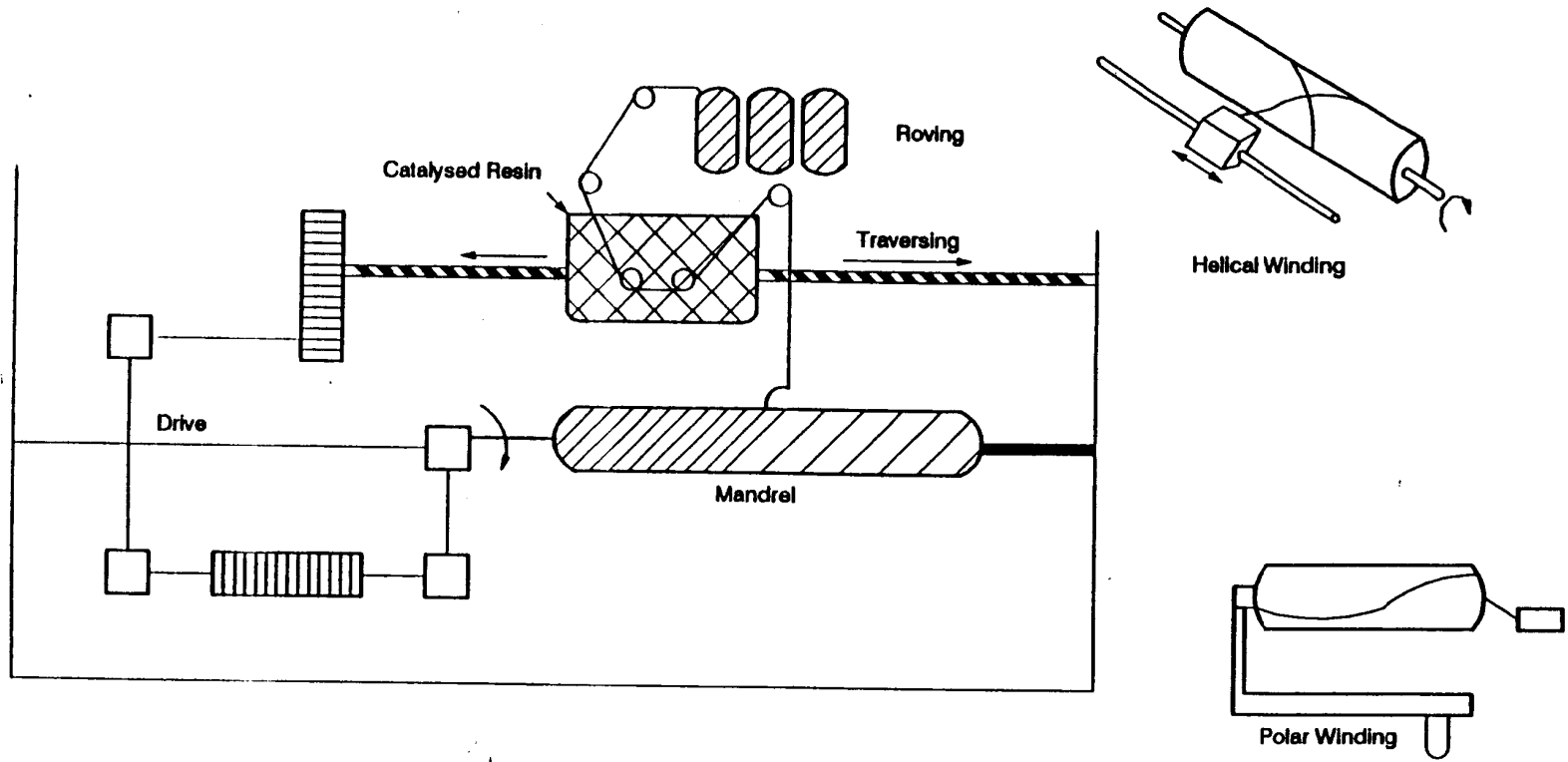

Figure 21. Typical Filament Winding Process

Press Molding--

Press molding includes compression, injection and transfer molding, and requires a large hydraulic press typically ranging from 454 to 4536 Mg (500 to 5000 tons) in capacity. Press molding uses either bulk molding or sheet molding compounds of resin and reinforcing materials.⁸

Bulk molding compounds are produced in rope or solid bulk form, and sheet molding compounds are produced in sheet form. Generally the UPR compounders have indoor UPR tanks containing less than 37,853 liters (10,000 gallons) each. The UPR is pumped from the storage tanks to a mixing tank where fillers (primarily calcium carbonate, clay or alumina) and catalysts are added. To make sheet molding compounds, the resulting paste is reinforced with glass fibers and formed into sheets on a continuous basis. To make bulk molding compounds, the paste is placed in a mixer with glass fibers. After compounding, the product is extruded into rope form or packaged in bulk form. Air emissions arise from storage tanks, mixing tanks, and mixing rooms.

Compression molding uses sheet molding compound where the sheet is compressed between heated molds and cured. Injection and transfer molding use bulk molding compound. The molding compound is forced through a small opening into a closed heated mold and cured.⁸

Continuous Lamination--

Garage doors, truck bed liners, patio covers, skylights, and solar collectors are some of the products made with unsaturated polyester resins using the continuous lamination process.

As shown in Figure 22, the polyester resin is first applied to a film on an impregnation table on a conveyor belt. The film forms the bottom surface of the product. This film can be made

114

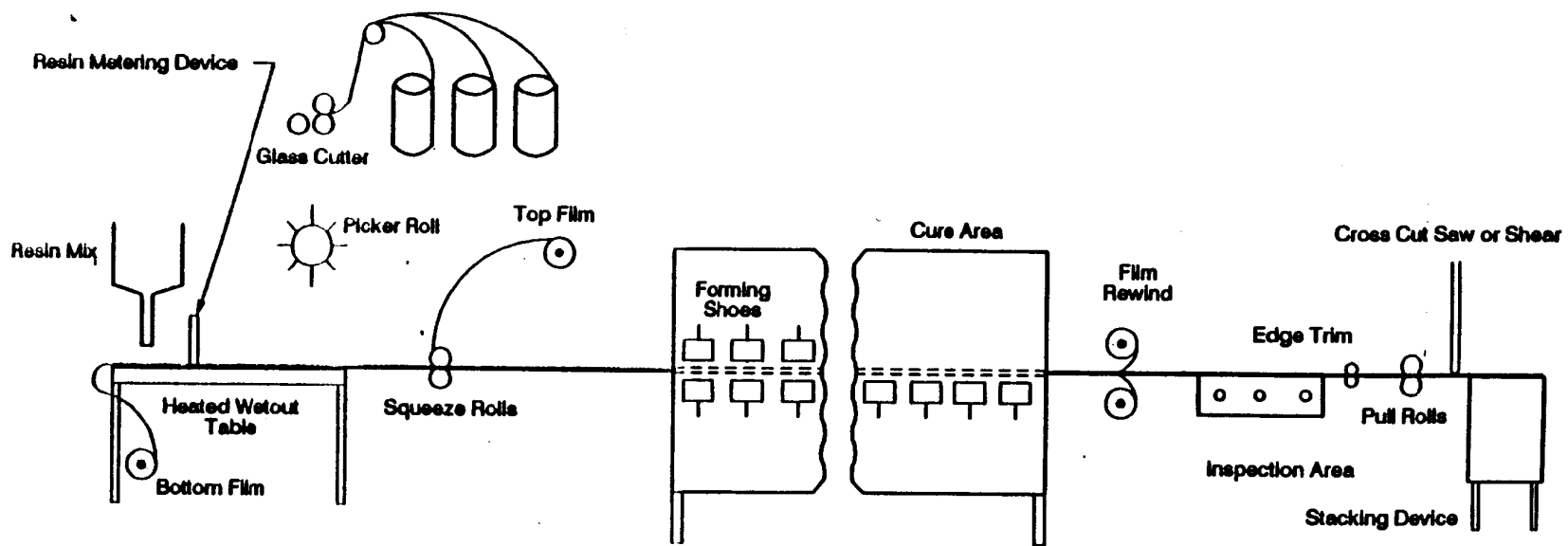

Figure 22. Typical Continuous Lamination Production Process⁷

4715059F

of polyester, cellophane, or nylon. The resin usually contains additives such as calcium carbonate or aluminum trihydrate to increase weather and flame resistance. Chopped glass is then added to the wet coat of resin, and a top layer of film is added and the layers are pulled through rollers to remove air bubbles. The conveyor belt then carries the laminate to a curing oven (200°C). After exiting the oven the films are removed and the laminate is trimmed to the desired size.⁷ Impregnation ensures a high degree of control of fiber/resin ratio and catalyst/resin ratio. Styrene emissions are reduced as compared to air sprayers.

Marble Casting--

The polyester resin used in synthetic marble casting usually has higher viscosity and lower monomer levels than the resins used for laminating and gel coats. Fillers and colorants are mixed with the resin in large vats. To achieve the marbled effect, the colorants are often hand stirred. The mixed resin is then hand poured into partially closed molds. The resin is cured at room temperature and, after curing, the mold is removed. Gel coats may also be used, in which case, they are applied to the mold surface before pouring in the resin. Sources of styrene emissions include equipment leaks, UPR storage tanks, process operations, and transfer and handling operations. The major sources of process operation emissions are the gel coat area and casting areas, where UPR is mixed and poured into molds.

Recently, the Emissions Measurements Branch of the U.S. Environmental Protection Agency contracted an environmental consulting firm to perform source testing at two cultured marble and sink manufacturing facilities. The primary purpose of the testing was to determine the emission rate of styrene during normal production activities at each facility. One of the facilities, characterized as a small, custom operation manufactures products consisting of bathtubs, bathroom counter

tops, bathroom sinks, showers, wall panels, and window sills.¹⁰ The other facility, characterized as a large production operation, manufactures products consisting almost entirely of bathroom sinks.¹¹ In addition to determining emission rates of styrene, particulate matter emissions were assessed at both facilities. Only styrene emissions are discussed in this report. The reader should refer to References 10 and 11 for information on particulate matter emissions from these facilities. Data gathered during the emissions testing were used to calculate styrene emission factors. A discussion of the production process and associated styrene emissions is presented below for each facility.

Process Description - Custom Operation¹⁰

The following discussion describes the production process at the small, custom facility. Figure 23 presents a schematic of the plant production area. The resin and gel coat are purchased in bulk liquid form in 55 gallon drums with no vapor suppressor added. The styrene content of the resin is 23 to 35 percent by weight, and 45 to 55 percent of the gel coat.

Several steps are taken to complete the finished product. The first step involves mold preparation. Molds are hand made, often using standard forms. After a mold is formed it is cleaned, waxed, and transported to a spray booth where a thin layer of gel coat is applied. After gel coating, molds proceed to the casting process which takes place in the mixing room. Resin, crushed marble filler, and catalyst are mixed in a closed process and applied to the molds which are then mechanically vibrated to remove bubbles and allow the resin to settle. The filled open molds are allowed to cure and harden in the curing area. After the resin has hardened, the molds are polished and sanded in the grinding room. Lastly, the finished product is taken to the warehouse for packaging and shipment.

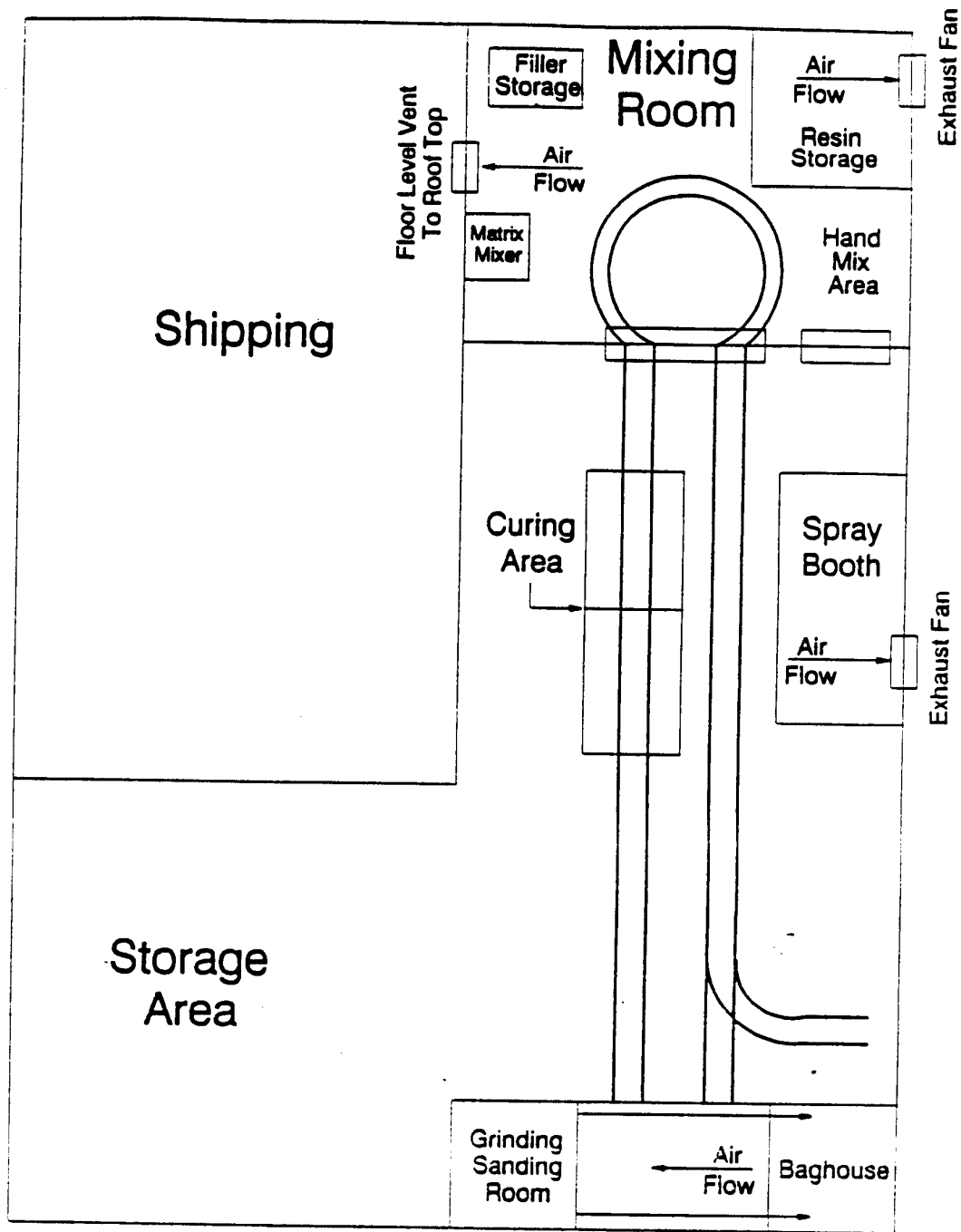

Figure 23. Small, Custom Operation Production Area

The entire production operation is contained in a large single room with the exception of the grinding and sanding area. This segment of the process is contained in a separate, enclosed area within a large manufacturing room. Work place air is vented to the outside through three exhaust fans. One fan exhausts air from the spray booth. A second exhaust fan and a floor level vent connected to a rooftop fan remove air from the resin mixing and casting area. A high efficiency filtration system controls particulate matter generated during the grinding and polishing area. Filtered air from this system is returned to the work place and not vented to the outside of the building. The only control devices used are the grinding room filtration system and a bank of filters at the spray booth.

Emission Measurements--Custom Operation

Styrene emissions originate from several points located within the building. Vapors are primarily generated in the spray booth during gel coating. Vapors are also generated from the automatic resin/catalyst/filler mixer.

Styrene emissions were measured from the spray booth, mixing room vent, and the mixing room exhaust using testing procedures meeting minimum EPA Method 1 requirements. Data from emission measurements and materials usage were used to calculate styrene emission factors. Emission factors were developed for the entire production operation. The emission factors calculated for the entire process incorporate emission rates measured from the mixing room vent, mixing room exhaust, and the spray booth. Table 24 presents the emission factors, along with the emission factors derived for the large production facility, which is discussed below.

Although emission factors cannot be developed for the individual operations, the results of the emission measurements indicate that spray booth emissions had a higher concentration of

TABLE 24. STYRENE EMISSION FACTORS FOR CULTURED MARBLE AND
SINK MANUFACTURING OPERATIONS

Facility	Process	Emission Factor	
		Lb styrene/Lb styrene consumed	Lb styrene/Lb resin and gel coat consumed (total)
Small custom operation	Entire process	0.01	0.005
Large production operation	Entire process	0.10	0.031
Large production operation	Tank loading	6.6×10^{-5} *	1.9×10^{-5} **

* Lb styrene/Lb styrene entering tank.

**Lb styrene/Lb resin entering tank (excluding gel coat).

styrene than emissions from the mixing room vent and mixing room exhaust. Likewise, the emission rates measured from the spray booth were considerably higher than the rates measured from the mixing room vent and exhaust. These results may reflect the fact that the gel coat (used in the spray booth) has a higher concentration of styrene than the resin.

Process Description - Large Operation¹¹

The second facility tested is a large production operation manufacturing products consisting almost entirely of bathroom sinks. Figure 24 is a diagram of the plant production area.

The facility purchases resin and gel coat in bulk liquid form. The styrene content of the resin ranges from 23 to 35 percent and from 45 to 55 percent for the gel coat. The resin is stored on site in four 4000 gallon tanks which are housed in a separate room attached to the main manufacturing area. The gel coat is purchased in 55 gallon drums. With the exception of the resin storage tanks which are contained in a separate room, the entire manufacturing operation is housed in a single large room. Each day, resin is mixed with crushed marble filler in three large open top mixing vats. Each vat will hold 1200 pounds of mix of which 23 percent by weight is resin. From these large vats, smaller 120 pound "working" batches are removed as needed. Catalyst is then added to the working batch before the mixture is poured onto molds.

The manufacturing process begins with the cleaning and waxing of molds. These molds then proceed to the spray booth, where a thin layer of gel coat resin is applied. A conveyer takes the gel coated molds through a gel coat drying oven. After drying, a premixed composition of resin, filler, and catalyst is manually applied to the molds using hand held trowels (pouring area). The back of the mold is then clamped into place and the assembly is mechanically vibrated in the shaker to remove bubbles

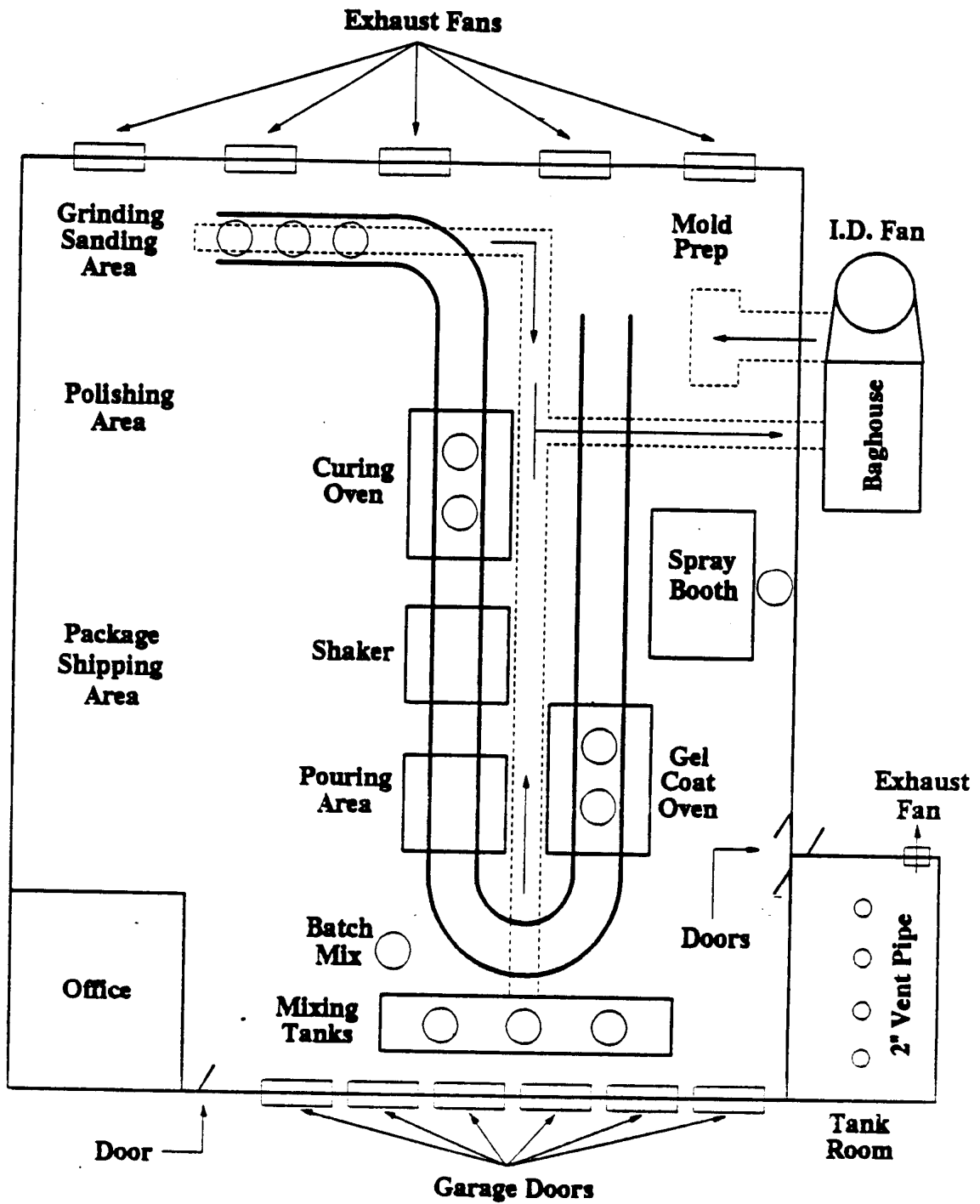

Figure 24. Large Operation Production Area

and allow the resin to settle. The molds remain on the conveyor and pass through a curing oven before proceeding to the grinding and sanding area and polishing area. Lastly, finished products are taken to the warehouse area for packaging and shipment.

Various exhaust fans are used to vent workplace air to the outside of the building. Both the gel coat oven and the curing oven have two ducts each that extend through the roof. The spray booth has a single duct extending through the roof. The tank room has a floor level intake vent that exhausts through a louvered fan mounted on an outside wall. Each of the four storage tanks is equipped with a two inch static vent pipe that extends through an outside wall. A high efficiency filtration system controls particulate from the grinding and sanding operations as shown in the dashed lines in Figure 24. Filtered air is returned to the work place and not vented to the outside of the building. Five louvered exhaust fans mounted close to the ceiling on the back of the outside wall provide general building exhaust. These fans tend to be operated only in the warmer months of the year.

Emission Measurements - Large Operation

Styrene emissions originate from several points within the building housing the entire operation. The adjacent tank room is also a source of styrene vapors. Styrene is emitted from the spray booth during gel coat application, the gel coat curing oven and the curing oven. The mixing vats and working batches are also sources of styrene vapors.

Styrene emissions were measured from the spray booth, gel coat oven, curing oven and tank room. Tank room styrene emissions were measured from the tank room floor level vent and from tank head space. Emission rates were calculated for the tank room vent, curing oven inlet and outlet, gel coat oven inlet and outlet, and the spray booth. The results indicate that the

curing oven inlet has the highest emission rate of styrene, followed by the spray booth, gel coat oven outlet, tank room vent, curing oven outlet, and lastly the gel coat oven inlet. Table 24 presents the emission factors developed for this operation. Styrene emission factors were also developed for tank loading. Table 24 presents the emission factors.

Pultrusion--

Pultrusion, which can be thought of as extrusion by pulling, is used to produce continuous cross-sectional lineals similar to those made by extruding metals such as aluminum. Reinforcing fibers are pulled through a liquid resin mix bath and into a long machined steel die, where heat initiates an exothermic reaction to polymerize the thermosetting resin matrix. The composite emerges from the die as a hot, constant cross-sectional profile that cools sufficiently to be fed into a clamping and pulling mechanism. The product can then be cut to desired lengths.⁷ The final pultruded product is typically at least 70 percent reinforcement by weight. These products are used in the electrical and building industries.

Resin Transfer Molding--

Resin transfer molding is a low pressure closed molding process which is normally carried out at room temperature. In the process, continuous or chopped strand glass fiber mats are placed in a mold, with catalyzed resin injected after the mold is closed. Because no resin surfaces are exposed to air during curing, styrene emissions from this molding process are greatly reduced as more styrene is retained in the mixture and added to the polymer as it cures, instead of volatilizing out of the mixture. Gel coats, which are often used with resin transfer molding, are applied to the molds (which may be reinforced plastic). After the gel coat cures, glass reinforcement is placed in the mold and resin is injected. This molding process

is best used for intermediate volume production of small to mid-sized components such as restaurant seats, hatches, doors, automotive parts, tubs, and shower units.⁸

Pultrusion--

Pultrusion, which can be thought of as extrusion by pulling, is used to produce continuous cross-sectional lineals similar to those made by extruding metals such as aluminum. Reinforcing fibers are pulled through a liquid resin mix bath and into a long machined steel die, where heat initiates an exothermic reaction to polymerize the thermosetting resin matrix. The composite emerges from the die as a hot, constant cross-sectional profile that cools sufficiently to be fed into a clamping and pulling mechanism. The product can then be cut to desired lengths.⁷ The final pultruded product is typically at least 70 percent reinforcement by weight. These products are used in the electrical and building industries.

Resin Transfer Molding--

Resin transfer molding is a low pressure closed molding process which is normally carried out at room temperature. In the process, continuous or chopped strand glass fiber mats are placed in a mold, with catalyzed resin injected after the mold is closed. Because no resin surfaces are exposed to air during curing, styrene emissions from this molding process are greatly reduced as more styrene is retained in the mixture and added to the polymer as it cures, instead of volatilizing out of the mixture. Gel coats, which are often used with resin transfer molding, are applied to the molds (which may be reinforced plastic). After the gel coat cures, glass reinforcement is placed in the mold and resin is injected. This molding process is best used for intermediate volume production of small to mid-sized components such as restaurant seats, hatches, doors, automotive parts, tubs, and shower units.⁸

Bag Molding--

Bag molding is best used to produce an intermediate volume of small to mid-size components such as seats, boat hatches, boat deck structures, and other items with shallow draft molds. Bag molding is conducted in sealed molds at room temperature. The process is initiated with gel coat applied to the surface of the mold. Glass reinforcing fibers and other materials are carefully cut to fit the mold and placed over it. Catalyzed resin is sprayed, pumped or poured over the layup. Once the layup materials are in place, the exposed area is covered with special layers of plastic which are sealed to the edges of the mold. Styrene emissions occur primarily from gel coat layup, UPR storage, and handling operations. The bag molding process uses a bag or flexible membrane to apply pressure during molding; usually in conjunction with an autoclave.¹² A reinforced laminate is layed up by hand or sprayed and pressure is applied by drawing a vacuum under a cellophane, vinyl, or nylon bag covering it. This assembly is then heated under pressure in an autoclave. The use of bag molding allows the final product to have a higher fiberglass to resin ratio.⁹

Spas/Tubs/Showers--

Open mold processes (spray layup) are used to fabricate spas, tubs, and showers. The process consists of gel coat sprayup and laminating operations. The polyester resin is hand rolled to build successive layers of reinforced plastic. The product is usually cured at room temperature. Significant sources of emissions are from UPR storage, transfer operations, and open mold operations.

Fiberglass Boat Production--

The fiberglass boat industry is a large consumer of UPR, with facilities scattered throughout the United States. The

production process is discussed separately here because no one specific process is used.⁹

Currently, there are over 900 fiberglass boat plants in the United States. The distribution of large fiberglass boat manufacturing facilities in 1987 by number in each State is shown in Table 25. Only 16 States do not have any fiberglass boat manufacturing establishments.¹³ Furthermore, 10 States have more than 10 boat manufacturing facilities and represent 65 percent of the facilities: California, Florida, Illinois, Indiana, Michigan, North Carolina, South Carolina, Tennessee, Texas, and Washington. The geographic distribution of major fiberglass boat manufacturing facilities by State is presented in Figure 25. Points that represent more than one establishment in a given city are assigned a numerical value. In general, the major locations of fiberglass boat manufacturing facilities are centered near lakes, rivers, and coastal areas.⁹

The styrene concentration of UPR used in fiberglass boat manufacture is usually 35 to 45 percent, and the styrene content of the gel coat is typically 45 to 50 percent. The most common fiberglass boat production process is contact molding, both spray layup and hand layup (Figure 26).¹² Concave female molds are preferred for boat hulls and decks as they leave smooth outer surfaces (male molds leave smooth inner surfaces). As discussed in the spray layup description, an airless spray gun is normally preferred. Gel coat application typically takes place in a ventilated spray area in boat manufacturing facilities. Hand and spray layup, as well as automated fabrication techniques, can be used in the manufacture of fiberglass boats. Often the first layer is allowed to cure to the touch before subsequent layers are applied to the desired thickness. Automated layup of large hull boats involves the simultaneous mechanical application of resin and reinforcement material, and may still require hand rolling to remove air bubbles. Spray layup is used for small parts, hulls, and decks. Hand rollers are also used to remove

TABLE 25. GEOGRAPHIC DISTRIBUTION OF THE FIBERGLASS BOAT
INDUSTRY BY NUMBER OF FACILITIES

Florida	77
Tennessee	40
California	23
Texas	21
Michigan	14
South Carolina	14
Indiana	13
Illinois	12
Washington	11
North Carolina	10
Arkansas	9
Massachusetts	9
Missouri	9
Louisiana	9
Georgia	8
Maryland	8
Minnesota	8
Rhode Island	7
Maine	7
Wisconsin	6
New Jersey	5
Ohio	5
Alabama	4
Arizona	4
Kansas	4
Oklahoma	4
Oregon	4
Connecticut	3
Kentucky	3
Mississippi	3
New York	3
Pennsylvania	2
Iowa	1
Nebraska	1
Utah	1
Virginia	1
TOTAL:	363

Source: Reference 13.

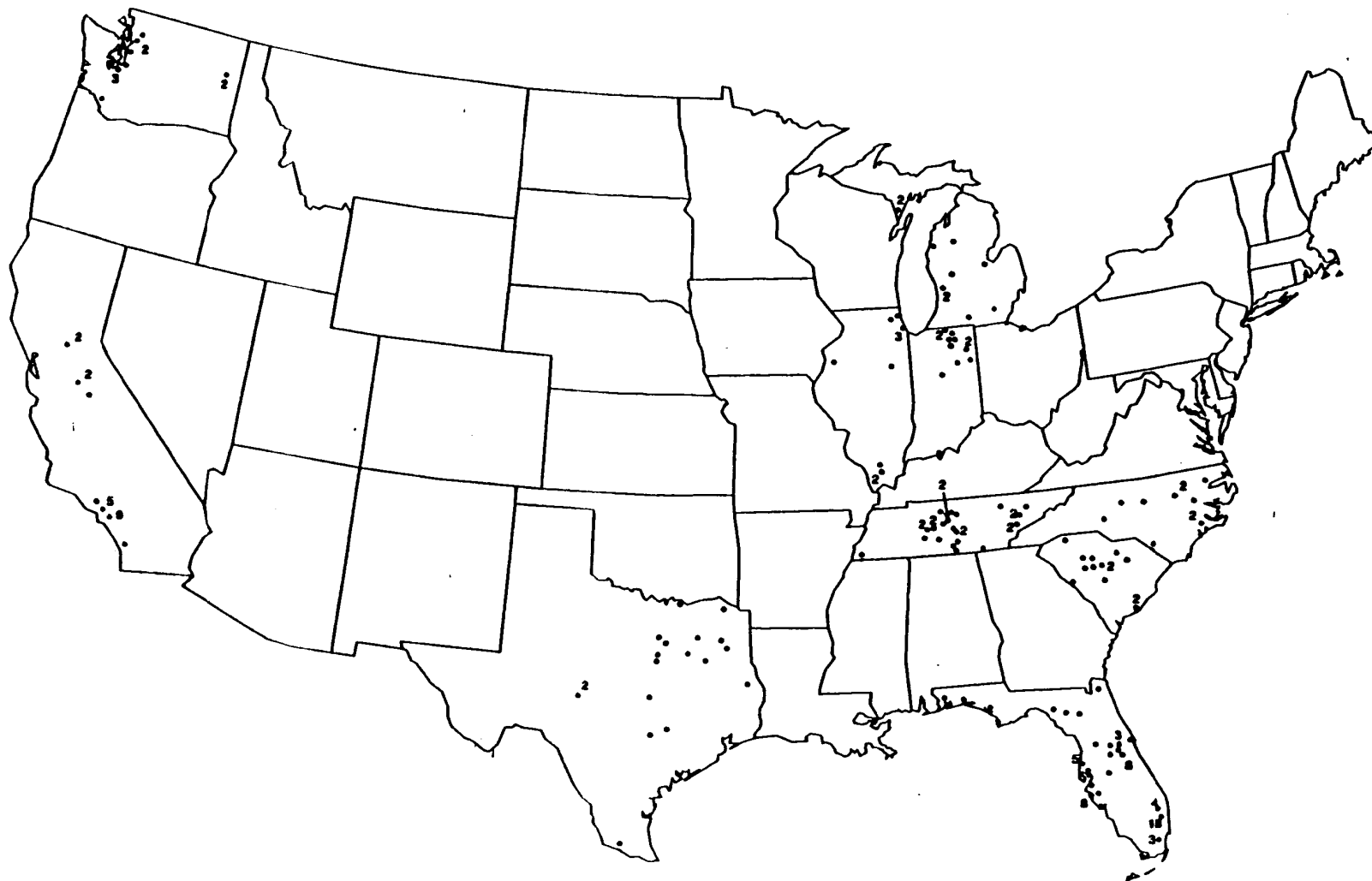
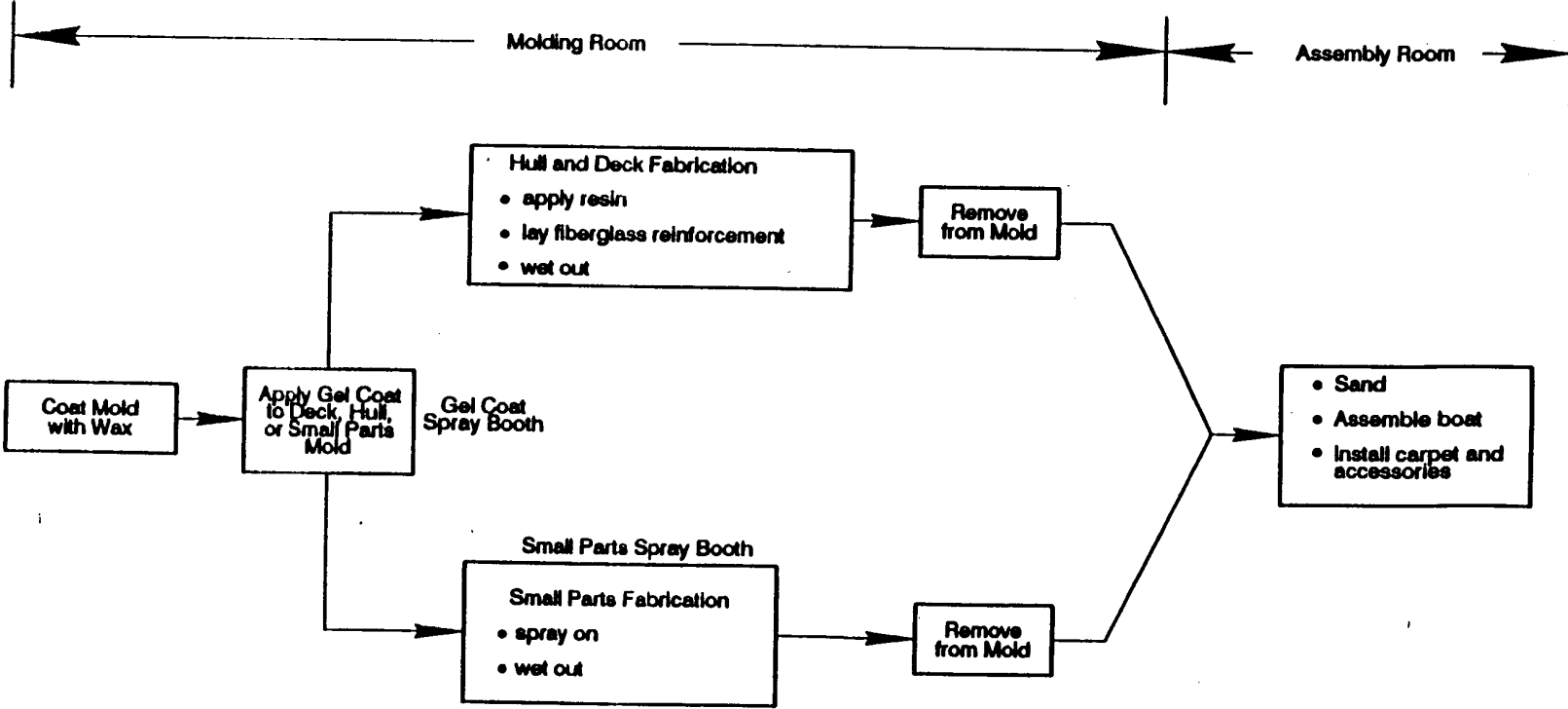

Figure 25. Geographic Distribution of Fiberglass Boat Manufacturing Facilities for States with More than Ten Facilities



129

Figure 26. Fiberglass Boat Production Process

air bubbles. Small parts are usually produced in a ventilated booth in the molding area. A separate assembly room is used for sanding parts and assembling the entire craft. Carpet and other fixtures are also installed in the assembly area.⁹

A less common molding method for the fiberglass boat manufacturing industry is the resin transfer molding process typically used to manufacture small parts such as boat seats, hatch covers, and bait boxes.¹⁴

Emission Measurements by Molding Process

The U. S. Environmental Protection Agency has published emission factors for fabrication processes using styrene as the monomer.⁷ These emission factors, shown in Table 26, are presented as pound VOC per pound monomer used. Styrene is by far the most common monomer used.⁷ Table 26 includes emission factors for vapor-suppressed (VS) resins, which can be used to reduce VOC emissions in place of nonvapor-suppressed (NVS) resins. Discussions with industry representatives indicate, however, that VS gel coats are not used, nor are VS resins used in closed molding processes.¹⁵

The California Air Resources Board (CARB) has also developed emission factors for UPR by molding process.^{14,16} These emission factors are shown in Table 27, and are based on resin monomer content, layup process, and microenvironmental conditions (such as temperature, indoor versus outdoor processes, and ventilation). It should be noted that the CARB emission factors are given in pounds of monomer emitted per pound of monomer used.

The emission factors published by EPA and CARB are similar for many of the processes shown in Tables 26 and 27. Notable exceptions are the emission factors for hand layup. The EPA emission factors are much lower than CARB's emission factors.

TABLE 26. VOC EMISSION FACTORS FOR POLYESTER RESIN PRODUCT
 FABRICATION PROCESS^a
 (Pound VOC emitted/pound monomer used)

Process	Resin		Gel Coat	
	NVS	VS ^b	NVS	VS ^b
Hand Layup	0.05-0.10	0.02-0.07	0.26-0.35	0.08-0.25
Spray Layup	0.09-0.13	0.03-0.09	0.26-0.35	0.08-0.25
Continuous Lamination	0.04-0.07	0.01-0.05	c	c
Pultrusion ^d	0.04-0.07	0.01-0.05	c	c
Filament Winding ^e	0.05-0.10	0.02-0.07	c	c
Marble Casting	0.01-0.03	0.01-0.02	f	f
Closed Molding ^g	0.01-0.03	0.01-0.02	c	c

^aRanges represent the variability of processes and sensitivity of emissions to process parameters. Single value factors should be selected with caution. NVS = nonvapor-suppressed resin. VS = vapor-suppressed resin.

^bFactors are 30-70% of those for nonvapor-suppressed resins.

^cGel coat is not normally used in this process.

^dResin factors for the continuous lamination process are assumed to apply.

^eResin factors for the hand layup process are assumed to apply.

^fFactors unavailable. However, when case parts are subsequently sprayed with gel coat, hand and spray layup gel coat factors are assumed to apply.

^gResin factors for marble casting, a semiclosed process, are assumed to apply.

Source: Reference 7.

TABLE 27. MONOMER-BASED EMISSION FACTORS FOR POLYESTER
RESIN/FIBERGLASS OPERATIONS
(Pound monomer emitted/pound monomer used)

Process	Resin		Gel Coat	
	NVS	VS	NVS	VS
Hand Layup Only	0.16-0.35	0.14-0.20	0.47	0.24-0.33
Spray Layup Only	0.09-0.13	0.05-0.09	0.16-0.35	0.13-0.25
Hand and Spray	0.11-0.19	0.06-0.13	0.31-0.38	0.16-0.27
Marble Casting	0.01-0.03	0.01-0.03	0.26-0.35	0.13-0.25
Continuous Lamination	0.06-0.13	0.06-0.13	NA	NA
Pultrusion	0.06-0.13	0.06-0.13	NA	NA
Filament Winding	0.06-0.13	0.03-0.09	0.26-0.35	0.13-0.25
Closed Molding	0.01-0.03	0.01-0.03	NA	NA

NA - Not applicable; gel coat normally not used for these processes.

Source: References 14 and 16.

Sample Calculation Using EPA Emission Factors⁷--

A fiberglass boat building facility consumes an average of 500 lb per day of styrene-containing resins using a combination of hand layup (65%) and spray layup (35%) techniques. The laminating resins for hand and spray layup contain 41.0 and 42.5 percent, respectively, of styrene. The resin used for hand layup contains a vapor-suppressing agent.

From Table 26, the factor for hand layup using a vapor-suppressed resin is 0.02 - 0.07 pounds VOC per pound monomer used. The factor for spray layup is 0.09 - 0.13 pounds VOC per pound monomer used (NVS). Assuming the midpoints of these emission factor ranges, and assuming that all VOC emissions are styrene, total styrene emissions are:

$$(500 \text{ lb}) \times [(0.41)(0.04)(0.65) + (0.425)(0.11)(0.35)] \\ = 13.5 \text{ lb/day.}$$

The emission factor ranges shown for marble casting in both tables include emissions for both gel coat spraying and casting. In general, the styrene emissions from synthetic marble casting are expected to be lower than those from other processes because of the closed mold nature of the process. Emissions vary with the amount of time the resin is exposed to air, and the majority of emissions were due to gel coat spraying.

For continuous lamination, exposure of the resin surface to air at the impregnation table is a source of styrene emissions. In addition, the ovens and the final sawing operations release some uncured resin to the atmosphere. The emissions from pultrusion operations are assumed to be the same as continuous lamination.

The prevalence of emission control use in the UPR industry is not known. The 1982 California study found that VS resins

were used for 26 percent of resin and gel coat application. Vapor suppressants are typically paraffin waxes that reduce styrene emissions by migrating to the surface and reducing volatilization of styrene. In laminating resins, the vapor suppressant content can range from 0.3 to 0.6 percent by weight. Other vapor suppressants in use are thermoplastics and fatty acid esters.

Other ways to reduce styrene emissions would be to change from open to closed molding, reduce rollout times, and in general improve housekeeping. In addition, the amount of polyester resin used can be reduced by redesigning products, adding more fillers, and improving spray gun efficiency. Reformulation of UPR could also be used to reduce the monomer content in the resin.

Emission Measurements for Fiberglass Boat Manufacture

Styrene can be emitted during storage and transfer of the polyester resin and from the lamination area. Resin is typically stored in outdoor temperature-controlled tanks and transferred to 55-gallon drums for spray application. Emissions from these sources are expected to be small compared to the process emissions.⁹

As discussed previously, styrene emissions occur during gel coat and resin application and from resin curing. Gel coats are typically sprayed on and the resins are applied either by hand or spray layup. The emission factors from hand and spray layup are shown in Tables 26 and 27.

Several factors influence the styrene process emissions during fiberglass boat manufacture. These include resin temperature, air temperature, air velocity in the lamination area, mold surface area, and spray gun transfer efficiency (Table 28). The reader is encouraged to contact the fiberglass

TABLE 28. FACTORS AFFECTING STYRENE EMISSIONS FROM LAMINATION

Factors	Effect on Emissions
Resin temperatures	Emissions increase as temperature rises
Air temperatures	Emission increase as temperature rises
Spray gun pressure/equipment atomization	Greater pressure increases the atomization which increases the overspray
Air velocity in lamination area	Greater air flow may increase evaporation resulting in increased emissions and decreased concentration
Mold surface area	Greater surface area allows more vaporization in terms of total mass
Resin/gel coat styrene content	Increase emissions from increased styrene monomer content

Source: Reference 9.

boat manufacturing facility to obtain specific information on the layup process used and environmental conditions in the lamination area in order to better estimate styrene emissions.

Control of styrene emission from fiberglass boat manufacturing can be accomplished with several of the options described above for UPR use including:⁹

- Reduction of styrene content in resin;
- Improved transfer efficiency of spray guns;
- Use VS resins; and
- Use of add-on controls.

The use of low styrene resins (35 percent styrene versus 43 percent) can potentially reduce total styrene emission by 19 percent from resin application and curing. Problems with application may occur as viscosity increases, and curing problems may result in structural defects. By improving the transfer efficiencies of the spray guns used to apply gel coat and resin, styrene emissions due to overspray can be reduced to 42 percent for gel coat and 33 percent for resin spray layup.⁹ Another option is the use of VS resins which may reduce styrene emissions by 30 to 50 percent during curing. However, the resins form a wax layer during curing which must be thoroughly removed between each laminate application to ensure interlaminar bonding. If maximum strength is not required, reducing the curing time between laminate applications can partially address the wax layer buildup problem.¹⁴ Because of the difficulty in removing the wax layer, VS resins are only suitable for selected applications.

Add-on controls that have been evaluated for use by the fiberglass boat manufacturing industry include incineration, adsorption (mass transfer) systems, and absorption (wet scrubber) systems. None of these add-on controls are currently used, however.¹⁵ Problems (primarily economic) with the use of add-on

controls by the fiberglass boat manufacturing industry are due to the high flow rates and low VOC concentrations in the exhaust.

POLYSTYRENE FOAM

Polystyrene foam (PSF) products consist of foam sheet, foam board, and expandable beads. These products are manufactured by either extrusion or expandable bead blowing. The density, strength, formability, and insulating qualities of PSF make it an ideal material for packing "peanuts," hamburger boxes, and hot or cold drink cups, and many other products. A 1988 estimate of end uses for polystyrene resin indicates that foam packaging accounts for 26 percent, disposables account for 16 percent, consumer and institutional products account for 16 percent, and expandable polystyrene (EPS) beads account for 11 percent of total United States polystyrene production. The remainder goes into electronics, compounding, furniture manufacturing, and construction.¹⁷ Most extruded PSF products are manufactured by polystyrene producers. Blowing agent is incorporated into the polystyrene as it is extruded. Expanded polystyrene products, however, are made from polystyrene beads which contain an inactive blowing agent. These beads are usually produced by the large chemical companies, but they are expanded and molded at different facilities. Although no information on styrene emissions from the manufacture of polystyrene foam was found in the literature, process descriptions and facility locations are provided. Table 29 lists the major end uses of PS foam board and sheet and presents total United States consumption of PS foam products in 1988. Table 30 indicates the number of PSF producers in the United States by State.

Process Description

Polystyrene is foamed through the use of physical blowing agents that are gases or liquids that are soluble in the molten polymer under pressure. Under depressurization, the blowing

TABLE 29. DOMESTIC CONSUMPTION OF POLYSTYRENE FOAM BY END USES

End Use	1988 (Mg)	1988 (MM lb)
Extruded Foam		
Board	66,679	147
Sheet		
Single Service Containers	156,038	344
Stock Food Trays	86,184	190
Egg Cartons	36,288	80
Other Foamed Sheet	<u>15,876</u>	<u>35</u>
Total Foamed Sheet	361,065	796
Expandable Beads		
Building and Construction ^a	77,112	170
Cups and Containers	75,298	166
Packaging	48,082	106
Loose Fill	27,216	60
Other EPS Products	<u>25,401</u>	<u>56</u>
Total EPS Bead Products	253,109	558

^aValues include construction uses other than insulation, such as wall and ceiling coverings and concrete filler.

Source: Reference 18.

TABLE 30. DISTRIBUTION OF PSF PRODUCERS BY STATE

Sheet, Film, Board, and Block Producers
Including Foam Blowers and Extruders

State	Number of Facilities
California	23
Pennsylvania	19
Michigan	14
Mississippi	14
New York	14
Ohio	14
Illinois	12
Massachusetts	12
Georgia	11
Missouri	9
New Jersey	9
Texas	8
Arkansas	7
Connecticut	7
Florida	6
Washington	6
Indiana	5
Wisconsin	5
Colorado	4
Kentucky	4
North Carolina	4
Virginia	4
Maryland	3
Minnesota	3
Tennessee	3
Alabama	2
Iowa	2
Nebraska	2
Rhode Island	2
South Carolina	2
Arizona	1
Hawaii	1
Idaho	1
Kansas	1
New Hampshire	1
Oklahoma	1
TOTAL:	237

Source: References 19, 20, and 27.

agent volatilizes, causing the polymer to foam through the formation of gas cells.

Polystyrene Foam Sheet--

The formation of PSF sheet is an extrusion process, commonly using two extruders in series or one extruder with two sections. The process produces foam sheets 1 to 7 mm thick, with densities of 32 to 160 kg/m³.²² A typical extruded PSF foam sheet manufacturing process flow diagram is shown in Figure 27. Polystyrene pellets are mixed with a small amount (0.2 to 2 percent) of powdered nucleating agent such as talc, or a combination of citric acid and bicarbonate of soda (Step 1).²² This mixture is fed into the primary extruder (Step 2). The extruder is heated to provide an increasing temperature profile along its length, so that the polystyrene melts. The blowing agent is injected as a liquid, under high pressure, into the primary extruder where it mixes with the molten polystyrene. A screen is used to remove impurities from the molten polystyrene before it enters the secondary extruder. The secondary extruder introduces a cooling profile that increases the mixture's viscosity and give it enough strength to contain the blowing agent as it expands (Step 3). As the viscous polystyrene mix leaves the second extruder through a die, it foams and partially solidifies. The blowing agent bubbles attach to the nucleating agent and a cellular structure is formed.

An annular extrusion die is used in extruded polystyrene sheet production, resulting in a tubular form (Step 4). Foaming initiates near the die outlet where the pressure rapidly decreases, allowing the blowing agent to volatilize. As the foamed polystyrene passes through the die, compressed air is applied, forming a skin on the outer surfaces. Additional foaming occurs outside the die as the polystyrene tube passes over a forming mandrel, which determines the final circumference of the foam tube (Step 5). At the end of the mandrel the tube is

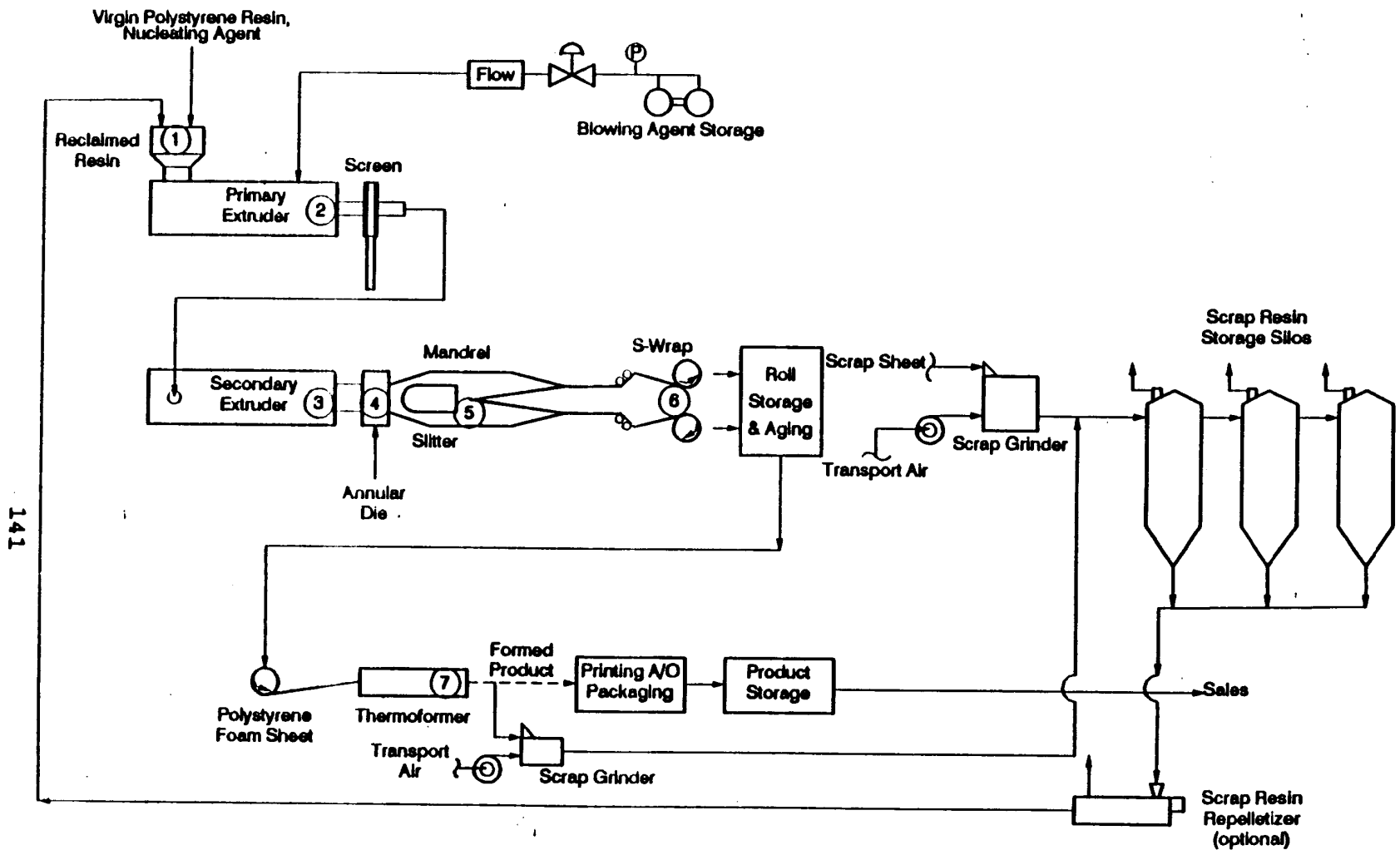

Figure 27. Flow Diagram of a Typical Polystyrene Foam Sheet Manufacturing Process

split lengthwise, flattened out, and an S-wrap, or sheet wrapping unit, winds the sheet into a roll (Step 6). The PSF sheet is then stored for two to five days. During this time, a portion of the blowing agent diffuses out of the foam cells and is replaced with air. This results in an optimum ratio of air to blowing agent within the foam cells, which will allow for postexpansion of the PSF during thermoforming.

Thermoforming is a process in which the extruded PSF sheet is reheated, then pressed between the two halves of a metal mold to form the desired end product such as fast-food containers (Step 7). After thermoforming, the molded shape is trimmed, sometimes printed, and packaged. Resulting scraps are ground and sent to scrap storage silos. This scrap is introduced into the primary extruder with virgin polystyrene. Polystyrene scrap typically makes up 35 percent of the total polystyrene fed to the primary extruder.

Extruded Polystyrene Foam Board--

Polystyrene foam board ranges from 1.25 to 15 cm thick, with densities of 27 to 66 kg/m³. The extrusion of PS foam boards is identical to that of PS foam sheets (Step 1: mixing PS pellets with nucleating agent, Step 2: primary extrusion, Step 3: secondary extrusion), with the exception that a simple slit aperture die is used instead of an annular die so that board is extruded as slabs rather than a tube (Step 4). Following cooling of the PS board, it is trimmed to size and packaged. A typical PSF board manufacturing process flow diagram is shown in Figure 28. Some board is laminated with facing materials that

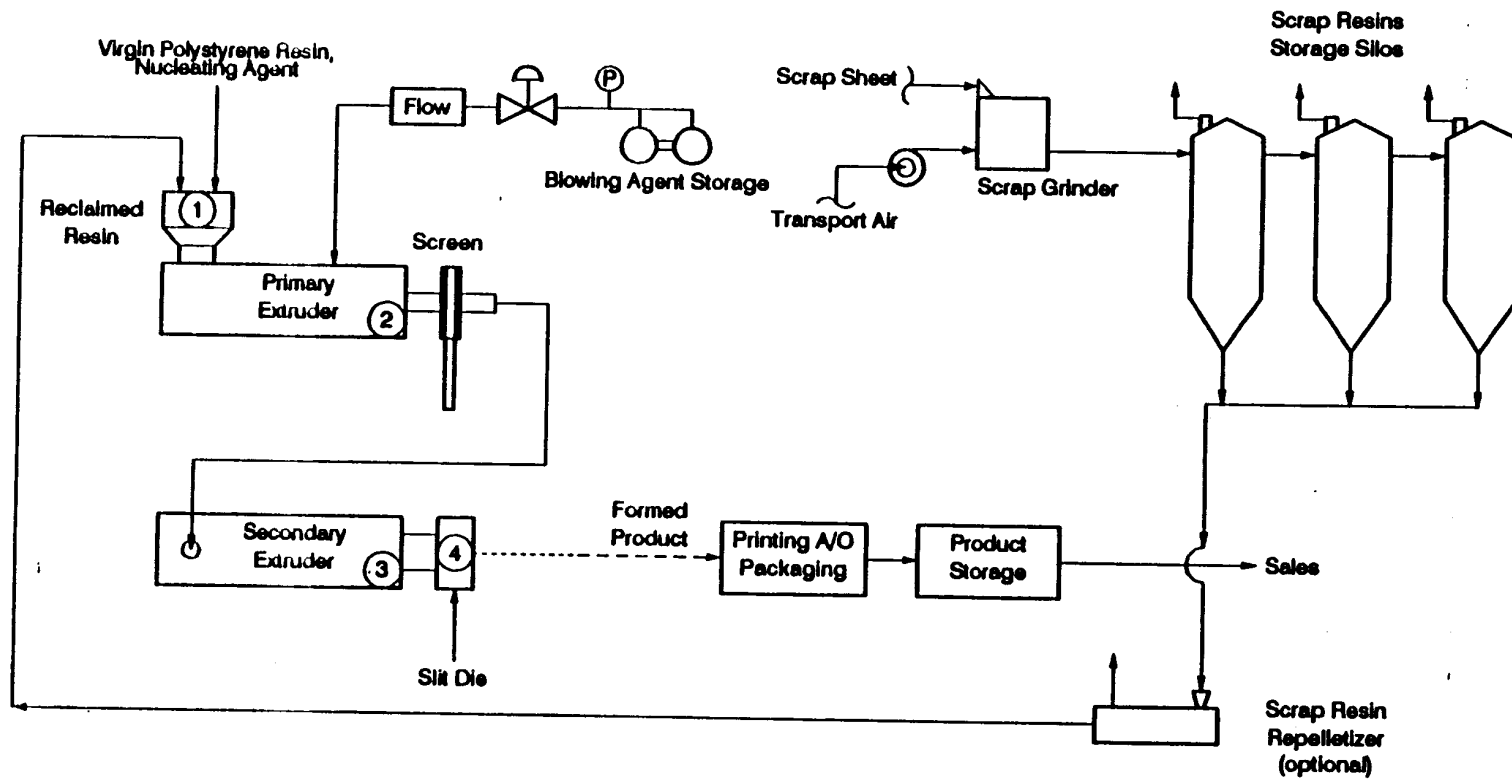

Figure 28. Flow Diagram of a Typical Polystyrene Foam Board Manufacturing Process

act as a vapor barrier or aid in the retention of low conductivity gas.²³

Expandable Polystyrene--

Expandable polystyrene is produced from spherical polystyrene beads which have been impregnated with a volatile hydrocarbon such as n-pentene or CFC-12. The polystyrene beads are produced by polymerizing styrene in a water suspension and adding it to a volatile liquid such as n-pentane. That serves as the blowing agent. The beads typically contain 5 to 7 weight percent of blowing agent. Prior to use, the beads are stored at temperatures below 21°C (70°F) to inhibit premature expansion.²⁴

A typical EPS bead manufacturing process flow diagram is shown in Figure 29. Normally, the beads are expanded in one step and molded in another. The beads are first expanded to achieve the desired molding density (Step 1). Expansion is promoted by exposing the beads to a continuous flow of steam or hot air at temperatures of 212 to 220°F within a process unit called a pre-expander. The amount of expansion is controlled by steam pressure and temperature and the bead feed rate.²³ Both batch and continuous processes are common. The transfer of heat vaporizes the volatile hydrocarbon trapped in the polystyrene matrix. As the volatiles are released from the matrix, the beads foam and expand.

Following the expansion process, the excess moisture acquired during the steaming is eliminated with hot air and the beads are transported to storage silos constructed of large mesh bags, where they are allowed to cool (Step 2).²⁵ The beads are allowed to age for 2 to 72 hours, during which time a portion of the remaining trapped volatile compounds evaporates and is replaced with air that diffuses into the beads. Air may be pumped through the beads to accelerate the aging process.

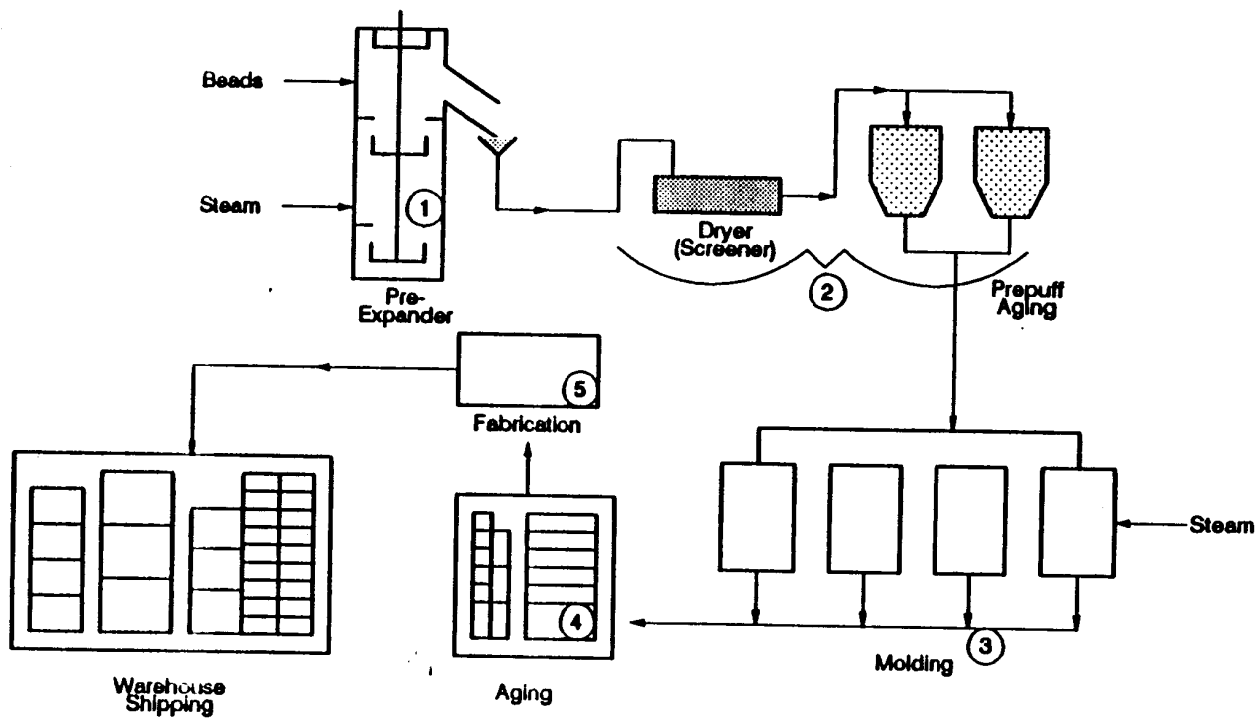

Figure 29. Flow Diagram of a Typical EPA Bead Process

Once aged, the beads are placed in molds and steam is used to expand the beads (Step 3). There are three types of molding: shape, block, and cup molding.²⁴ In shape molding, a premeasured amount of expanded beads is fed to a preheated split cavity mold. The beads are exposed to steam through small holes in the mold. The beads undergo further expansion, become soft and molten due to the transfer of heat from the steam, and fuse together under these conditions to form a single polymer mass. Following the expansion and fusing process, the mold and PSF part are cooled by circulating water through the mold. The mold is then opened, and the molded part is ejected by compressed air, mechanical pins, or manually. Shape-molded polystyrene foam products have densities ranging from 1.0 to 2.5 lb/ft³.²⁵

In block molding, pre-expanded beads are molded into large blocks of densities from 0.8 to 1.0 lb/ft³.²⁵ Following cooling and intermediate storage, blocks are sliced into sheets or custom fabricated shapes. Cup molding uses smaller beads and lower blowing agent content than block or shape molding. Cup density is over 3.5 lb/ft³.²⁴ Cups are molded at a moderate temperature; the final product is packaged in plastic and boxed for shipping.

Post molding operations of aging (Step 4) and fabrication (Step 5) are the final steps before printing and shipping of the product.

Polystyrene Loose Fill Packaging--

Polystyrene loose fill packaging is manufactured with a combination of extrusion and bead expansion. Recycled and new polystyrene are mixed with a nucleating agent and melted, as for extrusion. The blowing agent is injected under pressure, and the viscous mix is extruded, foaming as the blowing agent evaporates, and forming hollow strands as it exits through the die. The hollow strands are cut into 3/4-inch pieces. The strands are then steamed for further expansion, as are EPS beads.

Intermediate aging follows, and then the strands are further steam expanded, dried in ovens, and aged. The density of loose fill is about 0.2 lb/ft³.²⁵

Emissions from Polystyrene Foam Production

No information was located in the literature on styrene emissions associated with these processes. The reader is encouraged to contact individual facilities in question to obtain styrene emissions data.

REFERENCES FOR SECTION 6

1. A. T. Kearney. Impact Analysis of the EPA Office of Drinking Water Proposal to Regulate Styrene. Styrene Information Research Center. 1989.
2. Clark, R., et al. Potential Environmental Impact of Compounding and Fabricating Industries: A Preliminary Assessment. EPA-600/2-77-160. U. S. Environmental Protection Agency, Cincinnati, Ohio. 1977.
3. Pfaffi, P., et al. Degradation Products of Homopolymer Polystyrene in Air. Scand. J. Work Environ. Health 4 (suppl. 2): pp. 22-27. 1987.
4. Hoff, A., et al. Degradation Products of Plastics: Polyethylene and Styrene - Containing Thermoplastics - Analytical, Occupational and Toxicologic Aspects. Scand. J. Work Environ. Health 8 (suppl 2): p. 60. 1982.
5. Letter and enclosure from Terri Thomas, Ventura County Resource Management Agency, California, to D. Campbell, Radian Corporation. June 27, 1989.
6. Sprow, T. K. Unsaturated Polyester. Modern Plastics Encyclopedia. pp. 48-50. 1986-1987.
7. U. S. Environmental Protection Agency. Compilation of Air Pollutant Emission Factors. AP-42. U. S. Environmental Protection Agency, Research Triangle Park, North Carolina. p. 4.12-1 - 4.12-12.
8. Randazzo, C., SPI Composites Institute. Comments on draft "Locating and Estimating Air Emissions from Sources of Styrene" document. December 1990.
9. Stockton, M. B. and I. R. Kuo. Assessment of VOC Emissions from Fiberglass Boat Manufacturing. EPA-600/2-90-0019. U. S. Environmental Protection Agency, Research Triangle Park, North Carolina. 1990.
10. Radian Corporation. Determination of Styrene Emissions from the Cultured Marble and Sink Manufacturing Industry. Venetian Marble, Richmond, Virginia. Prepared for the U. S. Environmental Protection Agency, Research Triangle Park, North Carolina. April 1992.

11. Radian Corporation. Determination of Styrene Emissions from the Cultured Marble and Sink Manufacturing Industry. General Marble, Lincolnton, North Carolina. Prepared for the Emission Measurement Branch, U. S. Environmental Protection Agency, Research Triangle Park, North Carolina. August 1992.
12. Gibbs and Cox, Inc. Marine Design Manual for Fiberglass Reinforced Plastics. McGraw-Hill Book Company, New York, New York. pp. 4-16. 1960.
13. Thomas Register of American Manufacturers. Thomas Publishing Company, New York, New York. 1987.
14. Rogozen, M. B. Control Techniques for Organic Gas Emissions from Fiberglass Impregnation and Fabrication Processes. California Air Resources Board Report No. ARB/R-82/165. 1982.
15. Randazzo, C., SPI Composites Institute. Comments on draft "Locating and Estimating Air Emissions from Sources of Styrene" document. August 1991.
16. Rogozen, M. B. Development of an Inventory of Styrene Emissions from Polyester Resin/Fiberglass Fabrication in California. In: The Air Pollution Control Association, ed. A Specialty Conference on Emission Inventories and Air Quality Management. April 27-30, Kansas city, Missouri. pp. 363-378. 1982.
17. Chemical Profile; Polystyrene. Chemical Marketing Reporter, June 20:52. 1988.
18. Resin Report 1989. Journal of Modern Plastics, January, 1989.
19. Society of the Plastics Industry. Membership Directory, 1989.
20. U. S. Environmental Protection Agency. Industrial Process Profiles for Environmental Use: Chapter 10. Prepared by Radian Corporation, 1987.
21. Thomas Register of American Manufacturers. Thomas Publishing Company, New York, New York. 1988.
22. Kirk-Othmer Encyclopedia of Chemical Technology. 3rd ed. Styrene Polymers. Volume 16. John Wiley and Sons. New York, New York. pp. 148-245. 1979.
23. Foundation Design Handbook: Volume 1. Undercurrent Design Research. Underground Space Center, University of Minnesota.

24. Rodriquez, F. Principles of Polymer Systems. McGraw-Hill, Inc., New York, New York, 1970.
25. Tsitsopoulos, L. and M. Mills. Staff Report, Proposed Rule 1175: Control of Emissions from the Manufacture of Polymeric Cellular Products (Foam). South Coast Air Quality Management District; Rule Development Division, September, 1989.

SECTION 7
SOURCE TEST PROCEDURES

Styrene emissions can be measured by several methods, five of which are: (1) EPA Reference Method 18, which was announced in the Federal Register on October 18, 1983;¹ (2) NIOSH Analytical Method 1501 published in the NIOSH Manual of Analytical Methods on February 15, 1984;² (3) EPA Method 5040 which was published in EPA Report No. SW-846 in November 1986;³ (4) Compendium Method TO-14, determination of volatile organic compounds (VOCs) in ambient air using canister sampling;⁴ and (5) EPA Reference Method 8270.⁵

EPA Reference Method 18 applies to the sampling and analysis of approximately 90 percent of the total gaseous organics emitted from an industrial source; whereas NIOSH Method 1501 applies only to the collection and analysis of ten specific aromatic hydrocarbons. A method similar to the NIOSH Method 1501 is the American Society for Testing and Materials (ASTM) D 3686-84 method (published on June 29, 1984).⁶ EPA Method 5040 applies to the analysis of TENAX® and TENAX®/charcoal cartridges used to collect volatile principal organic hazardous constituents (POHCs) from wet stag gas effluents. Compendium Method TO-14 is applicable to specific VOCs that have been tested and determined to be stable when stored in pressurized and sub-atmospheric pressure canister.⁸ EPA Method 8270 is used to determine the concentration of semivolatile organic compounds using gas chromatography/mass spectrometry (GC/MS).

EPA REFERENCE METHOD 18

In Method 18, a sample of the exhaust gas to be analyzed is drawn into a Tedlar® or aluminized Mylar® bag as shown in Figure 30. The bag is placed inside a rigid, leakproof container and evacuated. The bag is then connected by a Teflon® sampling line to a sampling probe (stainless steel, Pyrex® glass, or

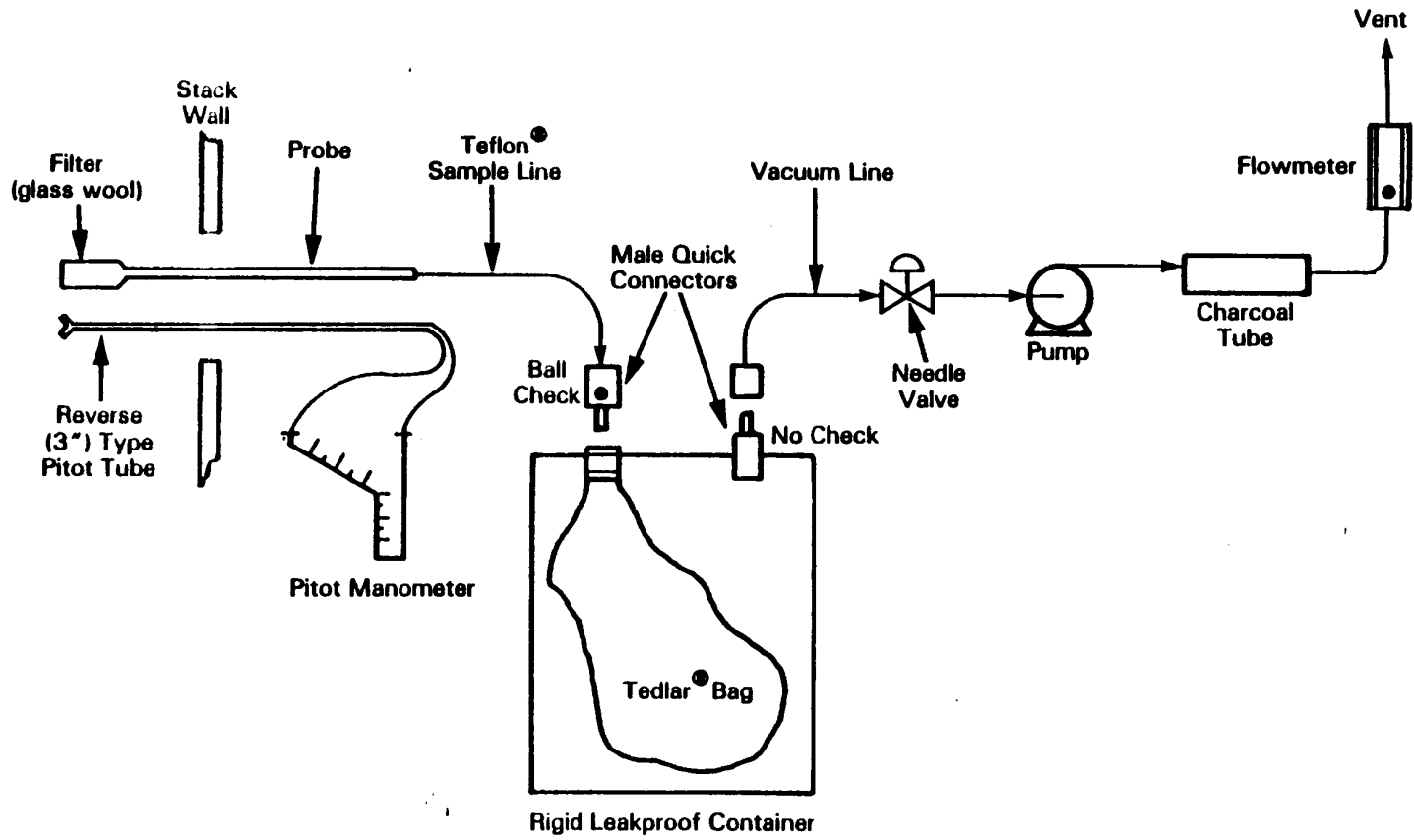

Figure 30. Integrated Bag Sampling Train

Teflon®) at the center of the stack. The sample is drawn into the bag by pumping air out of the rigid container.

The sample is then analyzed by gas chromatography (GC) coupled with flame ionization detection (FID). Based on field and laboratory studies, the recommended time limit for analysis is within 30 days of sample collection.^{7,8} The GC operator should select the column and GC conditions that provide good resolution and minimum analysis time for styrene. Zero helium or nitrogen should be used as the carrier gas at a flow rate that optimizes the resolution.

The peak areas corresponding to the retention times of styrene are measured and compared to peak areas for a set of standard gas mixtures to determine the styrene concentrations. The detection limit of this method ranges from about 1 part per million (ppm) to an upper limit governed by the FID saturation or column overloading. However, the upper limit can be extended by diluting the stack gases with the inert gas or by using smaller gas sampling loops.

When access to the sampling location is difficult, an alternative sampling method described in Section 7.4 of EPA Reference Method 18 may be preferred.⁹

NIOSH METHOD 1501

This method has limited application. The method applies only to ten specific aromatic hydrocarbons. Several necessary modifications are recommended if this method is to be used.⁹

In the NIOSH method, samples are collected with solid sorbent tubes containing coconut shell charcoal. Five to 14-liter air samples are collected with the use of a personal sampling pump at a known flow rate of ≤ 1 L/minute.²

Samples are desorbed with carbon disulfide and analyzed by GC equipped with an FID and a column capable of resolving styrene from the solvent front and other interferences. The column specified in NIOSH Method 1501 is a 3.0 m x 2 mm glass or stainless steel, 10% OV-275 on 100/120 mesh Chromosorb® W-AW, or equivalent.²

The amount of styrene in a sample is obtained from the calibration curve in units of milligrams per sample. Storage stability has not been assessed for this method, thus, analysis should occur as soon as possible following sample collection. Styrene can dimerize during handling and storage. The rate of dimerization is a function of temperature, increasing as the temperature increases. Consequently, samples should be stored at low temperatures.

This procedure is applicable for monitoring styrene air concentrations ranging from 2.17 to 8.49 mg. The GC column and operating conditions should provide good resolution and minimum analysis time.

EPA METHOD 5040

In Method 5040, a sample of stack gas is collected on TENAX® and TENAX®/charcoal sorbent cartridges using a volatile organic sampling train, (VOST).³ Because the majority of gas streams sampled using VOST will contain a high concentration of water, the analytical method is based on the quantitative thermal desorption of volatile POHCs from the TENAX® and TENAX®/charcoal traps. The analysis is by purge-and-trap GC/MS.

A schematic diagram of the analytical system is shown in Figure 31. The contents of the sorbent cartridges are spiked with an internal standard, thermally desorbed, and trapped on an analytical adsorbent trap directed into the GC/MS. The volatile

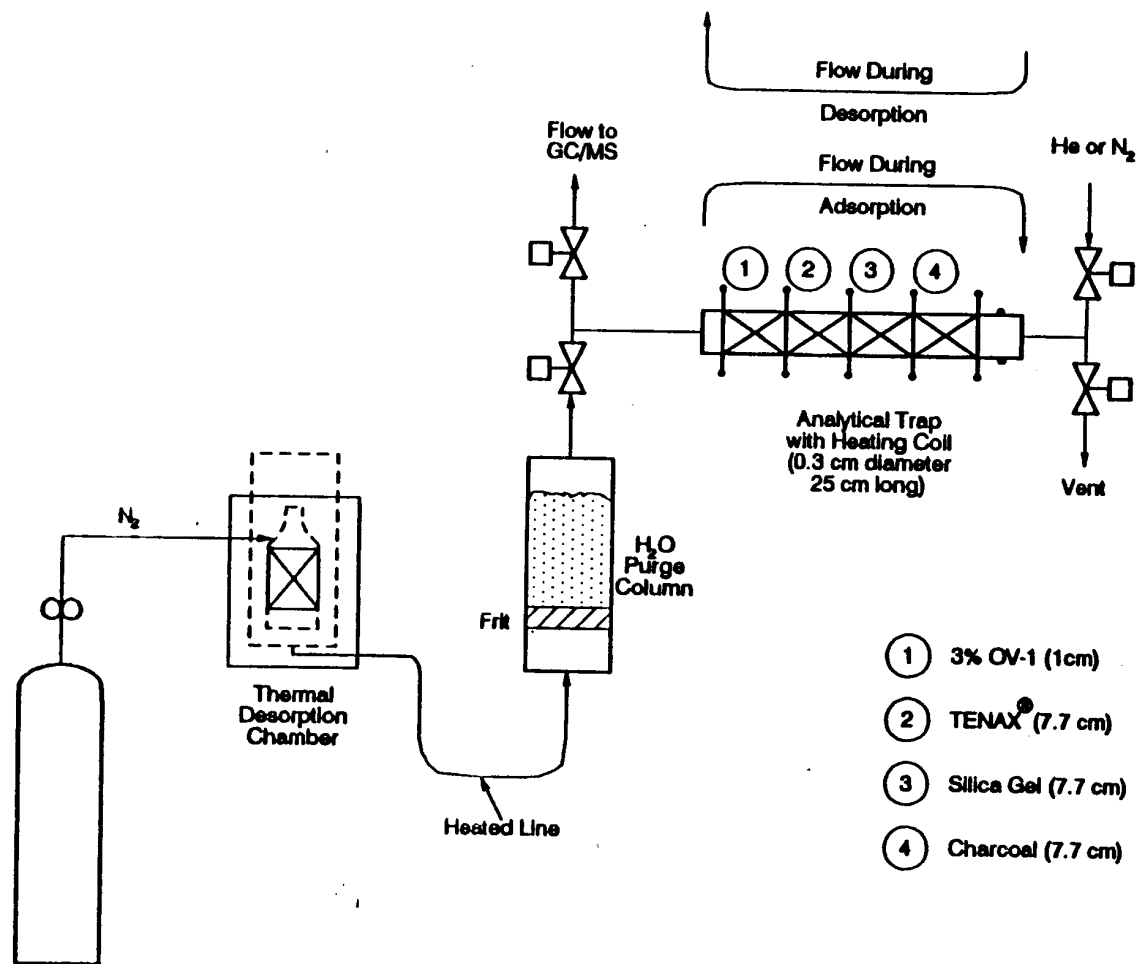

Figure 31. Schematic Diagram of Trap Desorption/Analysis System 3

POHCs are separated by temperature-programmed GC and detected by low-resolution mass spectrometry.

The concentrations of volatile POHCs are calculated using the internal standard technique. Sample trains obtained from the VOST should be analyzed within two to six weeks of sample collection. The desired target detection limit of this method is 0.1 ng/L (20 ng on a single pair of traps). Industry experience has found this method to be difficult to use and easily overloaded when the analyte concentration is in the high parts per billion (ppb) to ppm range.¹⁰ In addition, the cost associated with this method is higher than other analytical methods.⁹

COMPENDIUM METHOD TO-14

Method TO-14 is based on collection of whole air samples in SUMMA® passivated stainless steel canisters for analysis of volatile organic compounds (VOCs) in ambient air. A sample of ambient air is drawn through a sampling train composed of components that regulate the rate and duration of sampling into a pre-evacuated SUMMA® passivated canister.

The VOCs are separated by GC and measured by mass-selective detectors or multidetector techniques. The recommended time limit for analysis is within 14 days of sample collection.¹⁰ The column specified in Compendium Method TO-14 is a Hewlett OV-1 capillary column, 0.32 mm I.D. x 50 m with 0.88 um cross-linked methyl silicone coating, or equivalent.⁴ The wider J & W Scientific Company Megabore® column (i.e., 0.53 mm I.D.) can be used as long as the system meets user needs.⁴ Compounds have been successfully measured at the parts per billion by volume (ppbv) level using this method.

This method is designed for ambient, not source monitoring. Few laboratories offer it and it is quite costly. It is

reportedly difficult to use and the sample may be easily contaminated by the system. Recovery rates for reactive compounds tend to be very low.⁹

EPA REFERENCE METHOD 8270

Method 8270 describes conditions for GC/MS and is used to determine the concentration of semivolatile organic compounds in extracts prepared from all types of solid waste matrices, soils, and ground water. The analytical methodology will be equally applicable to an extract from sorbent media used in conjunction with EPA Method 0010 to sample stationary sources. The sorbent for Method 0010 is XAD-2® resin which is a styrene-divinylbenzene copolymer. Styrene monomer may also be present in the resin and may result in interferences. A different sorbent should be substituted for XAD-2®. Two possible candidates are TENAX®, which would require extraction with pentane or hexane, and XAD-7® which is an acrylic resin. Extraction efficiencies would need to be validated before these modifications are accepted.

Styrene is within the boiling point range for analysis by Method 8270, but is sufficiently volatile. Care must be taken in sample concentration to avoid loss. An adjustment in chromatographic conditions will be required to resolve the relatively volatile styrene from the solvent.

The practical quantitation limit for Method 8270 is approximately 50 ug/mL of extract. The entire sorbent module with filter is typically extracted and concentrated to a final volume of 1 mL. This final extract volume represents the entire volume of gas sampled.

REFERENCES FOR SECTION 7

1. 40 CFR Part 60, Appendix A, Method 18: Measurement of Gaseous Organic Compound Emissions by Gas Chromatography, pp. 868, 873-878, 886, 889, 895. July 1, 1989.
2. U. S. Department of Health, Education, and Welfare. NIOSH Manual of Analytical Methods, 3rd ed., Volume 2. National Institute for Occupational Safety and Health, Cincinnati, Ohio. pp. 1501-1 to 1501-7. 1984.
3. Method 5040: Protocol for Analysis of Sorbent Cartridges from Volatile Organic Sampling Train. Test Methods for Evaluating Solid Waste, 3rd ed., Vol. 1B: Laboratory Manual, Physical/Chemical Methods. EPA Report No. SW-846. November 1986.
4. Compendium Method TO-14: The Determination of Volatile Organic Compounds (VOCs) in Ambient Air Using Summa® Passivated Canister Sampling and Gas Chromatographic Analyses. Quality Assurance Division. Atmospheric Research and Exposure Assessment Laboratory, U. S. Environmental Protection Agency, Research Triangle Park, North Carolina. pp. 1-15, 18,19, 21-23. May 1988.
5. U. S. Environmental Protection Agency, Office of Solid Waste and Emergency Response. Method 8270: Gas Chromatography/Mass Spectrometry for Semivolatile Organics: Capillary Column Technique. Test Methods for Evaluating Solid Waste, 3rd ed. Report No. SW-846. Washington, D.C. 1986.
6. ASTM D3686-84. Annual Book of ASTM Standards, Volume 11.03. 1984.
7. Personal Communication. Moody, T. K., Radian Corporation, with Hartman, M., Radian Corporation, October 9, 1989. Discussion of styrene/butadiene stack sampling and analysis.
8. Personal Communication. Moody, T. K., Radian Corporation with Pau, J., U. S. Environmental Protection Agency, Atmospheric Research and Exposure Assessment Laboratory, October 10, 1989. Discussion of EPA Reference Method 18 in relation to styrene stack sampling.
9. Randazzo, C., SPI Composites Institute. Comments on draft "Locating and Estimating Air Emissions from Sources of Styrene" document. December 1990.
10. Personal Communication. Moody, T. K., Radian Corporation, with Rice, J., Radian Corporation, February 7, 1990. Discussion of Compendium Method TO-14.