

United States
Environmental Protection
Agency

Office of Air Quality
Planning And Standards
Research Triangle Park, NC 27711

EPA-450/4-84-007g
July 1984

AIR



LOCATING AND ESTIMATING AIR EMISSIONS FROM SOURCES OF CHROMIUM



EPA-450/4-84-007G

July 1984

Locating and Estimating Air Emissions From Sources of Chromium

U.S ENVIRONMENTAL PROTECTION AGENCY
Office of Air and Radiation
Office of Air Quality Planning and Standards
Research Triangle Park, North Carolina, NC 27711

This report has been reviewed by the Office of Air Quality Planning and Standards, U.S. Environmental Protection Agency, and has been approved for publication as recieved from Radian Corporation. Approval does not signify that the contents necessarily reflect the views and policies of the Agency, neither does mention of trade names or commercial products constitute endorsement or recommendation for use.

TABLE OF CONTENTS

	<u>Page</u>
List of Tables	v
List of Figures	viii
1. Purpose of Document	1
2. Overview of Document Contents	3
3. Background	5
Nature of Pollutant	5
Overview of Production and Use	9
Chromium production	9
Chromium uses	19
References for Section 3	27
4. Chromium Emission Sources	29
Direct Sources of Chromium	30
Chromite ore refining	30
Ferrochromium production	33
Refractory manufacture	52
Chromium chemicals manufacture	64
Chromium plating	77
Steel production	91
Electric arc furnaces and argon-oxygen decarburization vessels	91
Basic oxygen process furnaces	124
Open hearth furnaces	135
Leather tanning	140
Indirect Sources of Chromium	147
Coal and oil combustion	147
Cement production	160
Municipal refuse and sewage sludge incineration	165

TABLE OF CONTENTS (Continued)

	<u>Page</u>
Cooling towers	174
Asbestos mining and milling	181
Coke ovens	189
References for Section 4	196
5. Source Test Procedures	209
Literature Review of Sampling Methods	209
Literature Review of Analytical Methods	210
Extraction procedures	210
Analysis procedures	213
References for Section 5	221

LIST OF TABLES

<u>Table</u>	<u>Page</u>
1 Physical Properties of Chromium	6
2 Oxidation States of Chromium in Various Chromium Compounds and the Major Physical Properties of These Compounds	7
3 Composition of Typical Ferrochromium Alloys and Chromium Metal	13
4 List of Commercially Produced Secondary Chromium Chemicals and their General Uses	18
5 Major Chromium Uses and Key Chromium Chemicals Involved	25
6 Chromium Emission Factors for Chromite Ore Refining	33
7 Chromium Emission Factors from Processing of Raw Materials at Ferrochrome Plants	48
8 Chromium Emission Factors from Finishing Operations and Product Handling at Ferrochrome Plants	50
9 Chromium Emission Factors for Electric Arc Furnaces Used to Produce Ferrochromes	51
10 Location of Plants Producing Chromium Ferroalloys as of 1980	53
11 General Chromium Emission Factors for the Refractory Industry	63
12 Controlled Chromium Emission Factors for the Refractory Industry	65
13 Locations of Plants Producing Chromium Refractory Materials	66
14 Chromium Emission Factors for Sodium Dichromate Manufacturing	75
15 Chromium Emission Factors for Chromic Acid Production	76
16 Locations of Sodium Chromate and Sodium Dichromate Manufacturing Plants	77
17 Locations of Companies Producing Secondary Chromium Chemicals	78
18 Typical Chromium-Plating Conditions Using Conventional Baths	87

LIST OF TABLES (Continued)

<u>Table</u>	<u>Page</u>
19	Uncontrolled Chromium Emission Factors from One Hard Chromium Plating Facility 90
20	Fugitive Emissions Capture Technology Combinations (Carbon and Specialty Steel EAF) 112
21	Fugitive Emissions Capture Technology Combinations (Specialty Steel AOD) 115
22	Uncontrolled Chromium Emission Factors for Electric Arc Furnaces (EAFs) and Argon-Oxygen Decarburization Vessels (AODS) 117
23	Chromium Content of Electric Arc Furnace Dust for Each Step of Furnace Operation at One Facility 118
24	Locations of Electric Arc Furnaces in the United States -- 1981 119
25	Location of Steel Plants with EAFs and AOD Vessels -- 1981 122
26	Locations of Argon-Oxygen Decarburization (AOD) Vessels in the United States in 1981 123
27	Locations of Basic Oxygen Process Furnaces (BOPFS) in the Iron and Steel Industry 137
28	Locations of Steel Plants with Open Hearth Furnaces 141
29	Largest U. S. Leather Tanning Facilities and Locations 145
30	Chromium Content of Domestic Coals by Type 148
31	Chromium Content of Domestic Coals by Source 148
32	Chromium Content of Various Crude and Fuel Oils 149
33	Chromium Collection Efficiencies for Electrostatic Precipitators 152
34	Chromium Collection Efficiencies for Fabric Filters 152
35	Chromium Collection Efficiencies for Wet Scrubbers 153
36	Chromium Emission Factors for Oil Combustion 155
37	Chromium Emission Factors for Coal Combustion 157

LIST OF TABLES (Continued)

<u>Table</u>		<u>Page</u>
38	Chromium Emissions Factors for Cement Plants	164
39	Design Temperature Profile of a Sewage Sludge Multiple Hearth Furnace	170
40	Emission Factors for Chromium from Municipal Refuse and Sewage Sludge Incinerators	173
41	Population of Municipal Refuse and Sewage Sludge Incinerators in the United States in 1983	175
42	Chromium Emission Factors for Fresh Water Utility Cooling Towers	180
43	Chromium Emission Factors for Asbestos Mining and Milling	188
44	Locations of Asbestos Mines and Mills in 1981	190
45	Coke Plants in the United States as of January 1980	193
46	Instrumental Methods for the Determination of Chromium	214

LIST OF FIGURES

<u>Figure</u>		<u>Page</u>
1	Simplified flowchart for the production of chromium compounds and metallic chromium from chromite	10
2	Industrial recycling/reuse flow of chromium scrap	15
3	Primary and secondary use distribution of chromium in the United States	20
4	Final consumer use distribution of chromium in the United States in 1981	21
5	End use tree for sodium dichromate in 1982	24
6	Flow chart for chromite ore-refining	31
7	Flow chart of ferrochrome production by the electric arc furnace process	35
8	Open electric arc furnace	37
9	Semisealed electric arc furnace	39
10	Sealed electric arc furnace	40
11	Typical flow chart for the production of low-carbon ferrochrome by the exothermic silicon reduction process	42
12	Vacuum furnace for the production of low-carbon ferrochrome	43
13	Flow chart for production of chromium-containing basic brick by casting and pressing processes	55
14	Flow chart for production of chromic oxide bricks by casting and pressing processes	56
15	Flow chart of production of unformed refractories	57
16	Flow chart for the production of sodium chromate	69
17	Flow chart for the production of sodium dichromate from chromate liquor	70
18	Flow chart for chromic acid production	73
19	Flow chart for decorative chromium plating on a steel substrate	83
20	Flow chart for hard chromium plating	84
21	Cut-away view of electroplating tank	86

LIST OF FIGURES (Continued)

<u>Figure</u>	<u>Page</u>
22	Typical electric arc steel furnace 94
23	Argon-oxygen decarburization vessel 98
24	Direct-shell evacuation control (two views) 104
25	Side draft hood (two views) 105
26	Canopy hood capture system 107
27	Partial furnace enclosure 108
28	Total furnace enclosure 109
29	Diverter stack with canopy hood 113
30	Close-fitting hood with canopy hood 114
31	Top blown and bottom blown BOPF vessels 125
32	Steps for making steel by the basic oxygen process 128
33	Time sequence of top blown BOPF operations 129
34	Schematic cross section of a furnace shop 130
35	Geographic distribution of the U. S. BOPF steelmaking facilities in 1982 136
36	Flow chart for leather tanning process at plants which formulate their own chromium sulfate tanning solution 143
37	Basic process flow diagram for wet and dry cement production plants 161
38	Basic configuration of a municipal refuse incinerator 167
39	Schematic diagram of a typical multiple-hearth sewage sludge incinerator 168
40	Schematic diagram of a fluidized-bed sewage sludge incinerator 171
41	General mechanism of chromium emissions from cooling tower drift 178
42	Concentration of chromium in air as a function of distance from the cooling tower 179
43	Crushing of massive chrysotile ore 182

LIST OF FIGURES (Continued)

<u>Figure</u>		<u>Page</u>
44	Generalized flow sheet of an asbestos milling process	184
45	Metallurgical coke oven battery	191
46	Organic chromium species sampling configuration	211

SECTION 1

PURPOSE OF DOCUMENT

The U. S. Environmental Protection Agency (EPA), States, and local air pollution control agencies are becoming increasingly aware of the presence of substances in the ambient air that may be toxic at certain concentrations. This awareness, in turn, has led to attempts to identify source/receptor relationships for these substances and to develop control programs to regulate emissions. Unfortunately, very little information has been available on the ambient air concentrations of these substances or on the sources that may be discharging them to the atmosphere.

To assist groups interested in inventorying air emissions of various potentially toxic substances, EPA is preparing a series of documents such as this that compiles available information on sources and emissions of these substances. This document specifically deals with chromium. Its intended audience includes Federal, State, and local air pollution personnel and others who are interested in locating potential emitters of chromium and making gross estimates of air emissions therefrom.

Because of the limited amounts of data available on chromium emissions, and since the configuration of many sources will not be the same as those described herein, this document is best used as a primer to inform air pollution personnel about (1) the types of sources that may emit chromium, (2) process variations and release points that may be expected within these sources, and (3) available emissions information indicating the potential for chromium to be released into the air from each operation.

The reader is strongly cautioned against using the emissions information contained in this document to try to develop an exact assessment of emissions from any particular facility. Since insufficient data are available to develop statistical estimates of the accuracy of these emission factors, no estimate can be made of the error that could result when these factors are used to calculate emissions for any given facility. It is possible, in some extreme cases, that orders-of-magnitude differences could result between actual and calculated emissions, depending on differences in source configurations, control equipment, and operating practices. Thus, in situations where an accurate assessment of chromium emissions is necessary, source specific information should be obtained to confirm the existence of particular emitting operations, the types and effectiveness of control measures, and the impact of operating practices. A source test and/or material balance should be considered as the best means to determine air emissions directly from an operation.

SECTION 2

OVERVIEW OF DOCUMENT CONTENTS

As noted in Section 1, the purpose of this document is to assist Federal, State, and local air pollution agencies and others who are interested in locating potential air emitters of chromium and making gross estimates of air emissions therefrom. Because of the limited background data available, the information summarized in this document does not and should not be assumed to represent the source configuration or emissions associated with any particular facility.

This section provides an overview of the contents of this document. It briefly outlines the nature, extent, and format of the material presented in the remaining sections of this report.

Section 3 of this document provides a brief summary of the physical and chemical characteristics of chromium, its commonly occurring forms, and an overview of its production and uses. A chemical use tree summarizes the quantities of chromium produced by various techniques as well as the relative amounts consumed in various end uses. This background section may be useful to someone who needs to develop a general perspective on the nature of the substance and where it is manufactured and consumed.

Section 4 of this document focuses on major industrial source categories that may discharge chromium-containing air emissions. Section 4 discusses the production of chromium and chromium compounds, the use of chromium as an industrial feedstock, and the discharge of chromium from industrial sources due to its being a trace contaminant in fossil fuels. For each major industrial source category described in Section 4, example process descriptions and

flow diagrams are given, potential emission points are identified, and available emission factor estimates are presented that show the potential for chromium emissions before and after controls employed by industry. Individual companies are named that are reported to be involved with either the production and/or use of chromium based on industry contacts and available trade publications. Where possible, the chemical form of chromium emissions is identified as this parameter is important in considerations of health effects.

The final section of this document summarizes available procedures for source sampling and analysis of chromium. Details are not prescribed nor is any EPA endorsement given or implied to any of these sampling and analysis procedures. At this time, EPA has generally not evaluated these methods. Consequently, this document merely provides an overview of applicable source sampling procedures, citing references for those interested in conducting source tests.

This document does not contain any discussion of health or other environmental effects of chromium, nor does it include any discussion of ambient air levels or ambient air monitoring techniques.

Comments on the contents-or usefulness of this document are welcomed, as is any information on process descriptions, operating practices, control measures, and emissions information that would enable EPA to improve its contents. All comments should be sent to:

Chief, Source Analysis Section (MD-14)
Air Management Technology Branch
U. S. Environmental Protection Agency
Research Triangle Park, North Carolina 27711

SECTION 3

BACKGROUND

NATURE OF POLLUTANT

Pure chromium is a steel-gray, lustrous, hard crystalline metal. It occupies the 24th position in the Periodic Table and belongs to transition group VIB along with molybdenum and tungsten. It comprises about 0.037 percent of the earth's crust and therefore ranks 21st in relative natural abundance. It is more abundant than cobalt, copper, lead, nickel, cadmium, molybdenum, or zinc.¹⁻³ The major physical properties of elemental chromium are presented in Table 1.

Elemental or pure chromium metal is not found in nature. Instead, it occurs primarily in nature as a member of the spinel mineral group in the form of chromite ore or chrome iron ore. The Cr/Fe ratio in chromite varies considerably; therefore, the mineral is best represented by the general formula $(\text{Fe, Mg})\text{O} \cdot (\text{Cr, Fe, Al})_2\text{O}_3$. From a chromium recovery standpoint, the ideal chromite ore has the composition $\text{FeO} \cdot \text{Cr}_2\text{O}_3$, which contains about 46 percent chromium. The majority of the world's chromite supply comes from South Africa, Finland, the Philippines, and the U.S.S.R. Although chromite deposits are found in the United States, concentrations are so low that chromite mining is not economically feasible, and as such is not performed in this country.³

Chromium exhibits several oxidation states, ranging from -2 to +6, which dictate its chemical reactivity, and therefore, its environmental and biological significance. The oxidation states of chromium in various chemicals, along with the physical properties of these chemicals, is given in Table 2.⁴ The most common oxidation states of chromium are +3 and +6, or equivalently trivalent and

TABLE 1. PHYSICAL PROPERTIES OF CHROMIUM¹

Property	Value
atomic weight	51.996
isotopes, %	
50	4.31
52	83.76
53	9.55
54	2.38
crystal structure	body centered cube
density at 20°C, g/cm ³	7.19
melting point, °C	1875
boiling point °C	2680
vapor pressure, 130 Pa ^a b, °C	1610
heat of fusion, kJ/mol ^b	13.4-14.6
latent heat of vaporization at bp, kJ/mol ^b	320.6
specific heat at 25°C, kJ/(mol-K)(beta)	23.9 (0.46 kJ/kg-K)
linear coefficient- of thermal expansion at 20°C	6.2 x 10 ⁻⁶
thermal conductivity at 20°C, W/(m-K)	91
electrical resistivity at 20°C, μW-m	0.129
specific magnetic susceptibility at 20°C	3.6 x 10 ⁻⁶
total emissivity at 100°C nonoxidizing atm	0.08
reflectivity, R	
8 , nm	300 500 1000 4000
%	67 70 63 88
refractive index	
a	1.64-3.28
8	2,570-6,080
standard electrode potential, valence 0 to 3+, V	0.71
ionization potential, V	
1st	6.74
2nd	16.6
half-life of ⁵¹ Cr isotope, days	27.8
thermal neutron scattering cross section, m ²	6.1 x 10 ⁻²⁸
elastic modulus, GPa ^c	250
compressibility ^{a,d} at 10-60 TPa	70 x 10 ⁻³

^a To convert Pa to mm Hg, multiply by 0.0075.

^b To convert J to cal, divide by 4.184.

^c To convert GPa to psi, multiply by 145,000.

^d 99% Cr; to convert TPa to megabars, multiply by 10.

TABLE 2. OXIDATION STATES OF CHROMIUM IN VARIOUS CHROMIUM COMPOUNDS AND THE MAJOR PHYSICAL PROPERTIES OF THESE COMPOUNDS⁴

<u>Oxidation State</u> Compound	Formula	Appearance	Density (g/cm ³)	Melting Point (°C)	Boiling Point (°C)	Solubility
<u>Oxidation state 0</u>						
Chromium carbonyl	Cr(CO) ₆	Colorless crystals	1.77	150 (decomposes) (sealed tube)	151 (decomposes)	Slightly soluble in CCl ₄ ; insoluble in H ₂ O, (C ₂ H ₅) ₂ O, C ₂ H ₃ OH, C ₆ H ₆
Dibenzene- chromium(0)	(C ₆ H ₆) ₂ Cr	Brown crystals	1.519	284-285	Sublimes 150 (vacuum)	Insoluble in H ₂ O; soluble in C ₆ H ₆
<u>Oxidation state + 1</u>						
Bis(biphenyl)- chromium (I) iodide	(C ₆ H ₅ C ₆ H ₅) ₂ CrI	Orange plates	1.617	178	Decomposes	Soluble in C ₂ H ₅ OH, C ₅ H ₃ N
<u>Oxidation state + 2</u>						
Chromous acetate	Cr ₂ (C ₂ H ₃ O ₂) ₄ · 2H ₂ O	Red crystals	1.79			Slightly soluble in H ₂ O; soluble in acids
Chromous chloride	CrCl ₂	White crystals	2.93	815	1120	Soluble in H ₂ O to blue solution, absorbs O ₂
Chromous ammonium sulfate	CrSO ₄ (NH ₄) ₂ SO ₄ · 6H ₂ O	Blue crystals				Soluble in H ₂ O, absorbs O ₂
<u>Oxidation state + 3</u>						
Chronic chloride	CrCl ₃	Bright purple plates	2.87	Sublimes	885	Insoluble in H ₂ O soluble in presence of Cr ⁺²
Chronic acetyl- acetate	Cr(CH ₃ COCHCOCH ₃) ₃	Red-violet crystals	1.34	208	345	Insoluble in H ₂ O; soluble in C ₆ H ₆
Chromic potassium sulfate (chrome alum)	KCr(SO ₄) ₂ · 12H ₂ O	Deep purple crystals	1.826	89		Soluble in H ₂ O
Chromic chloride hexahydrate	[Cr(H ₂ O ₄ C ₁₂)C ₁ · 2H ₂ O	Bright green crystals	1.835	95		Soluble in H ₂ O, green solution turning green-violet
Chromic chloride hexahydrate	[Cr(H ₂ O) ₆]Cl ₃	Violet crystals		90		Soluble in H ₂ O, violet solution turning green-violet
Chromic oxide	Cr ₂ O ₃	Green powder or crystals	5.22	2435	3000	Insoluble
<u>Oxidation state + 4</u>						
Chromium(IV) oxide	CrO ₂	Dark-brown or black powder	4.98 (calculated)		Decomposes to Cr ₂ O ₃	Soluble in acids to Cr ⁺³ and Cr ⁺⁶

TABLE 2. OXIDATION STATES OF CHROMIUM IN VARIOUS CHROMIUM COMPOUNDS AND THE MAJOR PHYSICAL PROPERTIES OF THESE COMPOUNDS⁴

<u>Oxidation State</u> Compound	Formula	Appearance	Density (g/cm ³)	Melting Point (°C)	Boiling Point (°C)	Solubility
Chromium (IV) Chloride	CrCl ₄					
<u>Oxidation state + 5</u> Barium chromate(V)	Ba ₃ (CrO ₄) ₂	Black-green crystals				Slightly decomposes in H ₂ O; soluble in dilute acids to Cr ⁺³ and Cr ⁺⁶
<u>Oxidation state + 6</u> Chromium(VI) oxide	CrO ₃	Ruby-red crystals	2.7	197	Decomposes	Very soluble in H ₂ O; soluble in CH ₃ ⁻ COOH, (CH ₃ CO) ₂ O
Chromyl chloride	CrO ₂ Cl ₂	Cherry-red liquid	1.9145	-96.5	115.8	Insoluble in H ₂ O hydrolyzes; soluble in CS ₂ , CCl ₄
Ammonium dichromate	(NH ₄) ₂ Cr ₂ O ₇	Red-orange crystals	2.155	Decomposes 180		Soluble in H ₂ O
Potassium dichromate	K ₂ Cr ₂ O ₇	Orange-red crystals	2.676	398	Decomposes	Soluble in H ₂ O
Sodium dichromate	Na ₂ Cr ₂ O ₇ •2H ₂ O	Orange-red crystals	1.348	84.6	Decomposes	Very soluble in H ₂ O
Potassium chromate	K ₂ CrO ₄	Yellow crystals	2.732	971		Soluble in H ₂ O
Sodium chromate	Na ₂ CrO ₄	Yellow crystals	2.723	792		Soluble in H ₂ O
Potassium chloro- chromate	KCrO ₃ Cl	Orange crystals	2.497	Decomposes		Soluble in H ₂ O, hydrolyzes
Silver chromate	Ag ₂ CrO ₄	Maroon crystals	5.625			Very slightly soluble in H ₂ O; soluble in dilute acids
Barium chromate	BaCrO ₄	Pale yellow solid	4.496	Decomposes		Very slightly soluble in H ₂ O; soluble in strong acids
Strontium chromate	SrCrO ₄	Yellow solid	3.895	Decomposes		Slightly soluble in H ₂ O; soluble in dilute acids
Lead chromate	PbCrO ₄	Yellow solid Orange solid	6.12	844		Practically insoluble in H ₂ O; soluble in strong acids

hexavalent chromium.^{3,4} Trivalent chromium is chemically basic and the most stable form of the element because of its strong tendency to form kinetically inert hexacoordinate complexes with water, ammonia, organic acids, sulfate, halides, and urea.⁴ This characteristic has great relevance to the behavior of trivalent chromium in biological systems. Hexavalent chromium is acidic and is the most commercially, biologically, and environmentally important state of chromium. Hexavalent forms of chromium are almost always linked to oxygen and are, therefore, strong oxidizing agents. Characteristically, acidic hexavalent chromium forms chromate (CrO_4)²⁻ and dichromate (Cr_2O_7)²⁻ ions.³

At normal temperatures chromium metal resists corrosive attack by a wide variety of chemicals. It will, however, dissolve in several common acids including hydrofluoric, hydrochloric, hydrobromic, and sulfuric with the evolution of hydrogen. Chromium is not attacked by phosphoric acid or organic acids such as formic, citric, and tartaric; however, it is slowly attacked by acetic acid. The corrosion resistance properties of chromium can be increased by depositing a thin oxide film on the metal surface, and thereby introducing a condition to the chromium known as passivity. Chromium can be passivated and rendered relatively nonreactive by the action of nitric acid (in which it is insoluble), chromic acid, or other oxidizing agents. It can also be passivated by superficial exposure and oxidation of the metal in air, although this technique is not as effective as oxidation by nitric or chromic acid.³

OVERVIEW OF PRODUCTION AND USE

Chromium Production

Chromium Ore Mining--

As illustrated in Figure 1, all chromium metal and chromium compounds that are produced in the United States are derived from

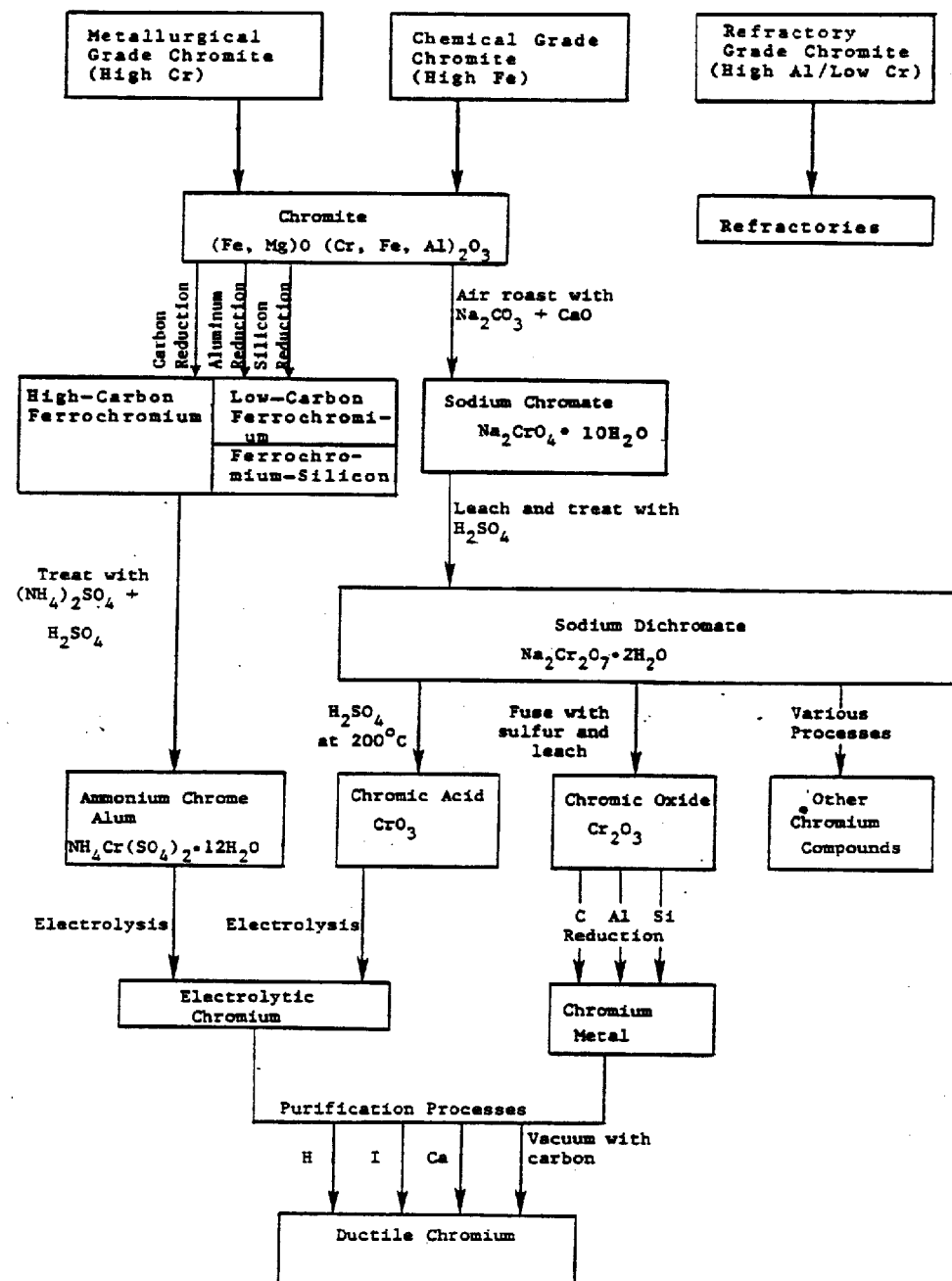

Figure 1. Simplified flowchart for the production of chromium compounds and metallic chromium from chromite.¹

various grades of chromite ore. Three basic grades of chromite ore are used to produce chromium compounds (including chromium metal):¹

- S** high chromium chromite ore, containing 46 percent or more of chromium oxide (Cr_2O_3)
- high iron chromite ore, containing 40-46 percent of Cr_2O_3
- S** high aluminum or low chromium chromite ore, containing more than 20 percent aluminum oxide (Al_2O_3) and more than 60 percent $\text{Al}_2\text{O}_3 + \text{Cr}_2\text{O}_3$

Chromite ores are generally classified according to the type of production process the chromite ore is eventually used in. Metallurgical chromite refers to the high chromium content chromite ore, chemical chromite to the high iron content chromite ore, and refractory chromite to high aluminum/low chromium content chromite ore.

Chromite ore has not been commercially mined in the United States since 1961 when the U. S. Defense Production Act was phased out. The phasing out of this program eliminated government sponsorship and subsidization of chromite mining activities, thereby making them economically infeasible.⁵ The United States owns chromite deposits in Maryland, Montana, North Carolina, California, Wyoming, Washington, Oregon, Texas, and Pennsylvania; however, the low chromium content of these deposits makes mining excessively expensive. In 1982, the U. S. imported 456 Gg (507,000 tons) of chromite, mostly from Albania (0.8 percent), Finland (8.9 percent), Madagascar (8.1 percent), Pakistan (0.6 percent), the Phillipines (13.8 percent), South Africa (54.6 percent), Turkey (6.3 percent), and the U.S.S.R. (6.7 percent).⁶

Production of Ferrochromium and Chromium Metal from Metallurgical Chromite--

Metallurgical grade chromite refers to chromite that is used to produce several grades or types of ferrochromium, chromium metal, and

chromium additives. The primary forms of ferrochromium are classified as high-carbon, low-carbon, and ferrochromium-silicon. High-carbon ferrochromium generally contains 5 to 6.5 percent carbon and 65 to 70 percent chromium. Low-carbon ferrochromium contains 67 to 75 percent chromium but only 0.025 to 0.05 percent carbon. Ferrochromium-silicon has a chromium content ranging from 35 to 41 percent and a maximum carbon content of 0.05 percent. Table 3 summarizes the compositional structure of the more prominent types of ferrochromium and chromium metal.¹

High-carbon ferrochromium is produced in a submerged electric arc furnace by reducing chromite with coke. Low-carbon ferrochromium is produced by reducing chromite with silicon in an electric arc furnace. The intermediate product of this reaction is ferrochromium-silicon. To obtain low-carbon ferrochromium, this intermediate product is further treated in an open, arc-type furnace with additional chromite or a chromic oxide-containing slag. In every ferrochromium production process, molten product ferrochromium is tapped from the furnace, hardened by rapid cooling, broken into chunks, and graded into compositional subgroups.^{1,7}

In the most prevalent electrolytic method of chromium metal production, high-carbon ferrochromium, in solution with other compounds, is used to generate a chromium ammonium sulphate solution or chrome-alum electrolyte. This chrome-alum electrolyte solution undergoes electrolysis to produce Chromium metal. The deposition cycle for this process lasts 72 hours with chromium metal eventually being deposited on stainless steel cathodes. The chromium metal produced by this operation is about 99.8 percent pure. The second type of electrolytic chromium metal production involves the electrolysis of a chromic acid/ionic catalyst solution, with the resultant deposition of chromium metal. The deposition cycle for this process lasts 80 to 90 hours and produces a final chromium metal that is slightly purer than that obtained from chrome-alum electrolysis.⁶

TABLE 3. COMPOSITION OF TYPICAL FERROCHROMIUM ALLOYS AND CHROMIUM METAL ¹

Grade	Chromium	Silicon	Carbon	Sulfur ^a	Phosphorus ^b	Other ^b
ferrochromium						
high-carbon	66-70	1-2	5-6.5	0.04	0.03	
high-carbon, high-silicon						
blocking chrome	55-63	8-12	4-6	0.03		
exothermic ferrochrome	41-51	9-14	3.6-6.4	0.03		
foundry ferrochrome	55-63	8-12	4-6			
refined chrome	53-63	2:5 ^a	3-5	0.03		
SM ferrochrome	60-65	4-6	4-6			4-6 manganese
charge chromium						
50-55 percent chromium	50-56	3-6	6-8	0.04	0.03	
66-70 percent chromium	66-70	3 ^a	6-6.5	0.04	0.03	
low-carbon:						
0.025 percent carbon	67-75	1 ^b	0.025 ^a	0.025	0.03	
0.05 percent carbon	67-75	1 ^b	0.05 ^a	0.025	0.03	
Simplex	63-71	2.0 ^a	0.01 to 0.025			
ferrochromium-silicon:						
36/40 grade	35-37	39-41	0.05 ^a			
40/43 grade	39-41	42-45	0.05 ^a			
chromium metal						
electrolytic	99.3 ^c	0.01 ^a	0.02 ^a	0.03		0.5 oxygen ^a 0.05 nitrogen ^a
aluminothermic	99.3 ^c	0.15 ^a	0.05 ^a	0.015	0.01	0.2 oxygen ^a 0.3 aluminum ^a

^a Maximum value.

^b Difference between sum of percentages shown and 100 percent is chiefly iron content.

^c Minimum value.

The only other source of chromium metal production comes from recycling chromium scrap metal. The main source of scrap chromium is scrap stainless steels and chromium alloys. It is estimated that only about 15 percent of the available scrap chromium is being recovered and recycled as new chromium metal.¹

The flow of chromium scrap through industry is shown in Figure 2.8 Recycling is generally performed by the firms producing the stainless steels and alloys and by specialty firms engaged in secondary metals recovery. Although there is a considerable amount of chromium contained in various industrial waste products (e.g., baghouse dusts, slags, pickling liquors, plating and etching wastes, used refractories, and processing sludges), collection and processing costs hinder economical recovery on a large scale.⁸ Note, in Figure 2, the term runaround (home) scrap means scrap that has been generated within a facility producing a chromium-containing steel or alloy, while new (prompt industrial) scrap refers to chromium scrap generated by consumers of chromium-containing metals.

In 1982, the United States ferrochromium and chromium metal industry consisted of 11 plants operated by eight different companies. These plants produced a combined total of approximately 83 Gg (91,900 tons) of high- and low-carbon ferrochromium and 25 Gg (27,400 tons) of ferrochromium-silicon, chromium metal, and chromium additives.⁶ Data are not available in the literature to separate the production totals of individual ferrochromium grades. However, in the first quarter of 1983, the Ferroalloy Association reported that only one plant in the country was actively producing ferrochromium. All other plants had suspended production of ferrochromium due to low demand brought on by a depressed steel industry and the ability of the steel industry to obtain cheaper ferrochromium from foreign sources. The Ferroalloy Association estimated that in the latter part of 1982 and in early 1983, 95 percent of the ferrochromium consumed in the United States was imported.⁹ The increase in ferrochromium imports and the resulting decline in domestic ferrochromium production is attributable to a worldwide trend in chromite-producing countries to vertically integrate their chromium industries. Now,

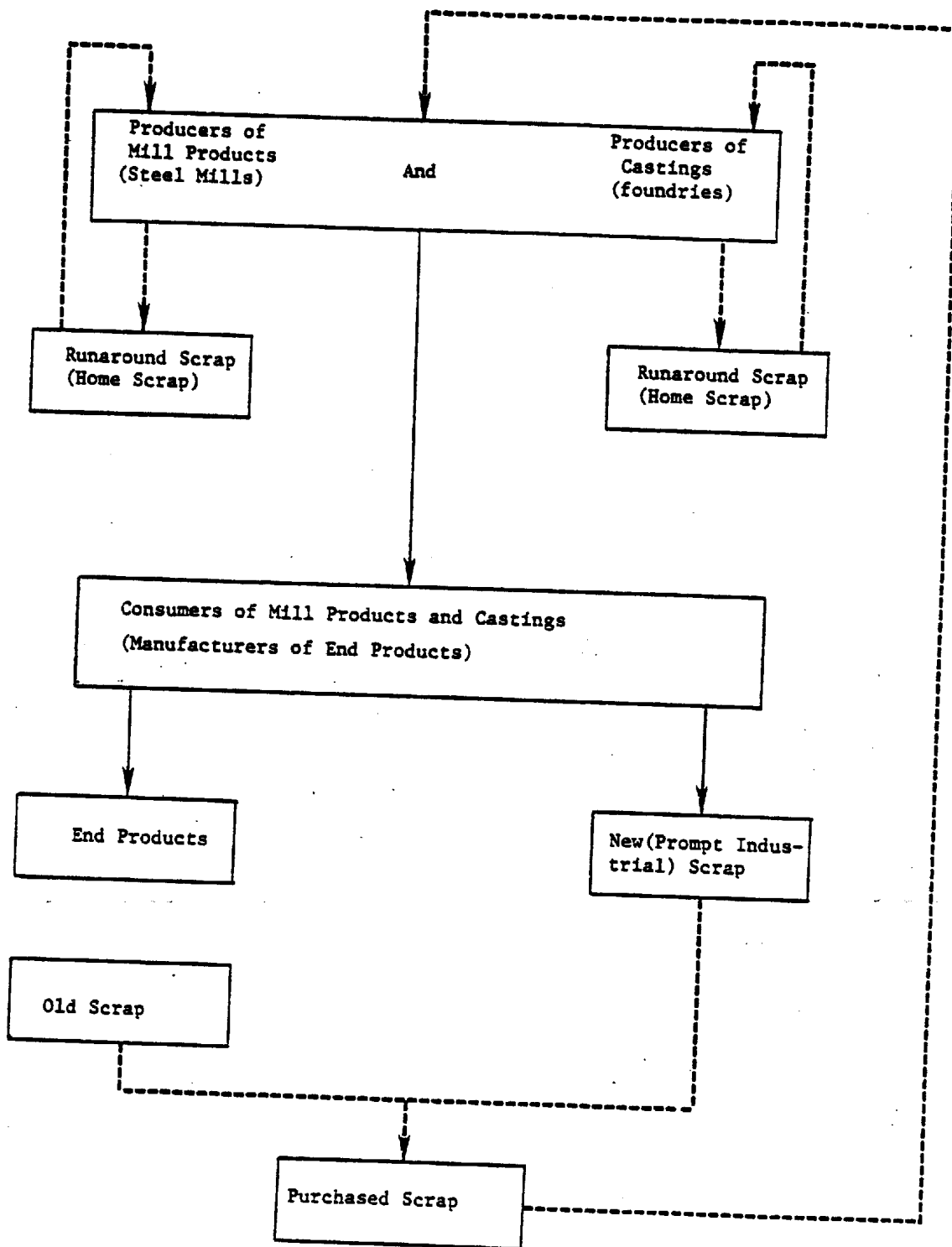

Figure 2. Industrial recycling/reuse flow of chromium scrap.⁸

only exporting a portion. The major part of the chromite supply is being processed by the producing country directly into ferrochromium and sold to the industrial users such as the United States or Japan. Lower labor, energy, and transportation costs allow the chromite-producing countries to sell their ferrochromium at lower prices than domestic ferrochromium companies can.^{6,9} Changes or upturns in the domestic steel industry that significantly alter the demand for ferrochromium could help bring several of the domestic ferrochromium plants back on line.⁹

Production of Sodium Chromate/Dichromate and Secondary Chromium Compounds from Chemical Chromite--

Chemical grade chromite refers to chromite that is used to produce sodium chromate ($\text{Na}_2\text{CrO}_4 \cdot 10 \text{H}_2\text{O}$) and sodium dichromate ($\text{Na}_2\text{Cr}_2\text{O}_7 \cdot 2\text{H}_2\text{O}$), the basic chemicals from which all other secondary chromium chemicals originate.¹⁰⁻¹³ In the United States there are three companies producing sodium chromate and dichromate chemicals at three plant locations. Sodium chromate is only produced as an end product chemical at two of the sites.¹⁴ Because of concerns of disclosing proprietary data, production information on sodium chromate is unavailable. However, the national sodium dichromate production capacity as of January 1983 was 205 Gg (228,000 tons) per year.¹⁵

Sodium chromate is produced by roasting finely ground chromite ore with soda ash or with soda ash and lime in a kiln. When sodium chromate is the desired endproduct, recovery is accomplished by leaching and crystallization steps. However, sodium chromate is generally not recovered, but instead is converted directly to sodium dichromate by treating it with sulfuric acid.^{1,10,16} Following sulfuric acid treatment, the final sodium dichromate product is obtained after a series of evaporation, crystallization, and drying steps. A sodium sulfate by-product is also produced during the dichromate process and is generally sold to the kraft paper industry.

As many as 40 secondary chromium chemicals are produced commercially from sodium dichromate raw materials. A list of the chromium chemicals produced in the United States is given in Table 4 (excluding sodium chromate and dichromate). The more significant secondary chromium chemicals include potassium chromate and dichromate, ammonium dichromate, chromic acid, basic chromic sulfate, chromic oxide, and chrome pigments (chrome oxide green, chrome yellow, chrome orange, molybdate chrome orange, and chrome green).^{1,10} Chromic oxide may be used subsequently to produce chromium metal by a pyrometallurgical reduction process using aluminum (aluminothermic process). In the aluminothermic process, chromic oxide is mixed with powdered aluminum, placed in a refractory vessel, and ignited. The reaction is exothermic and self-sustaining, with chromium metal and aluminum oxide being generated. Chromium metal produced by this method is 97 - 99 percent pure. Additional thermal methods of chromium metal production involve the reduction of chromic oxide with silicon in an electric arc furnace and the low pressure reduction of chromic oxide with carbon in a refractory vessel.^{6,17}

There are approximately 30 companies engaged in manufacturing secondary chromium compounds from sodium dichromate.^{14,18}

Production of Refractories from Refractory Chromite--

Refractory chromite refers to the grade of chromite that is used in the production of refractory brick and shapes. Refractory chromite is mostly used to manufacture basic (as opposed to acidic) non-clay refractories. Pure chromite ore, mixtures of chromite and magnesite, and mixtures of chromite and alumina are used to manufacture the refractory brick. The proportion of chromite used is related to the specific temperature and corrosion resistance requirements imposed by the refractory's end use.¹⁹

The production of chromite-containing refractory consists of four general steps: raw material processing, materials forming, firing, and final processing. In the raw material processing

TABLE 4. LIST OF COMMERCIALY PRODUCED SECONDARY CHROMIUM CHEMICALS AND THEIR GENERAL USES ^{1,14,18}

Chromium Chemical ^a	Number of Production Sites ^b	General Use
Chromic acid(Chromium trioxide)	2	Electroplating
Chromium acetate	6	Printing and dyeing textiles
Chromium acetylacetonate	3	Catalysts, antiknock compounds
Chromium monoboride	1	Unknown
Chromium carbide	1	Metallurgy
Chromium carbonyl	2	Catalysts
Chromium chloride, basic	1	Metal treatment
Chromium chloride	2	Metal treatment
Chromium diboride	1	Unknown
Chromium difluoride	1	catalysts
Chromium dioxide	1	Magnetic tape
Chromium 2-ethylexanoate (Chromic octoate)	2	Unknown
Chromium fluoride	1	Mordants, catalysts
Chromium hydroxide	1	Pigments, catalysts
Chromium hydroxy diacetate	1	Unknown
Chromium hydroxy dichloride	1	Unknown
Chromium naphthenate	2	Textile preservative
Chromium nitrate	2	Catalysts, corrosion control
Chromium oleate	2	Unknown
Chromium oxide (Chrome oxide green)	6	Pigments
Chromium phosphate	2	Pigments, catalysts
Chromium potassium sulfate (Chrome alum)	1	Photographic emulsions
Chromium sulfate	2	Catalysts, dyeing, tanning
Chromium sulfate, basic	1	Tanning
Chromium triacetate	1	Unknown
Chromium trifluoride	1	Printing, dyeing, catalysts
Chrome lignosulfate	1	Drilling muds
Potassium chromate ¹ Metal treatment		
Potassium dichromate	1	Tanning, dyeing, pigments
Lead chromate	5	Pigments
Zinc chromate ³ Corrosion control		
Ammonium dichromate	2	Printing, pyrotechnics
Barium chromate	2	Pyrotechnics
Calcium chromate	3	Corrosion control
Cesium chromate	1	Electronics
Copper chromate, basic	1	Wood preservative
Magnesium chromate	1	Refractory, catalysts
Strontium chromate	3	Corrosion control pigment
Iron chromite	2	Refractory

^a List does not include sodium chromate and sodium dichromate.

^b Several sites product multiple chromium chemicals.

step, chromite, magnesite, dolomite, and other raw materials are crushed, calcined, ground, and sized. In the forming step, the prepared raw materials are homogeneously mixed and formed into bricks and shapes. In the firing step, the formed brick and shapes are either dried and fired in a kiln or they are fusion-melted and cast into molds. The final processing step can consist of simple product packaging or it can involve more detailed operations such as final grinding and milling, tar impregnation, and tempering. Each of the more detailed finishing operations is performed to impart certain characteristics to the refractory to improve its end use performance.²⁰ In 1984, 26 companies operating a total of 43 plants are producing refractory from chromite ore raw material.^{21,22}

Chromium Uses

In 1982, 491 Gg (545,000 tons) of chromite ore were consumed in the United States and converted into chromium-containing products.⁶ The domestic consumption of chromite raw materials can essentially be attributed to three primary user groups or industries: metallurgical, chemical, and refractory (see Figure 1). Of the total chromite consumed in 1982, 49 percent or 240 Gg (267,000 tons) was for metallurgical uses, 36 percent or 177 Gg (196,200 tons) was for chemical uses and 15 percent or 74 Gg (81,800 tons) was for refractory uses.⁶ Within these primary consumption groups several secondary chromium materials are produced that function either as a final product (e.g., refractory) or as an intermediate in the manufacture of other consumer goods (e.g., stainless steel). Figure 3 illustrates the qualitative distribution of chromium use in both the primary and secondary consuming sectors.²³ A broader and more quantitative perspective of chromium consumption in the United States, as defined by the Standard Industrial Classification (SIC) category in which final use of the chromium occurs, is presented in Figure 4.⁸ Domestic consumption and distribution patterns of chromium within the metallurgical, chemical, and refractory use groups are summarized in the following sections.

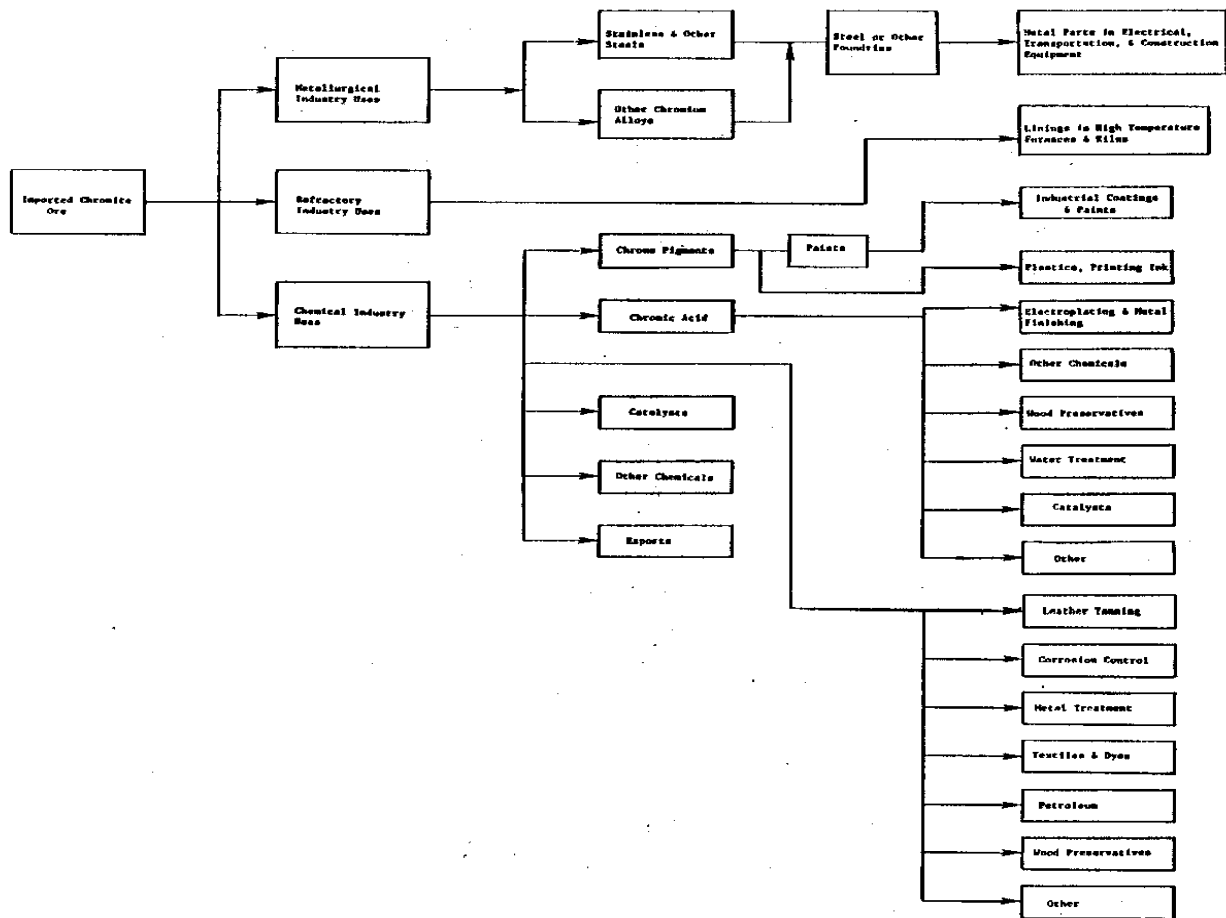

Figure 3. Primary and secondary use distribution of chromium in the United States.²³

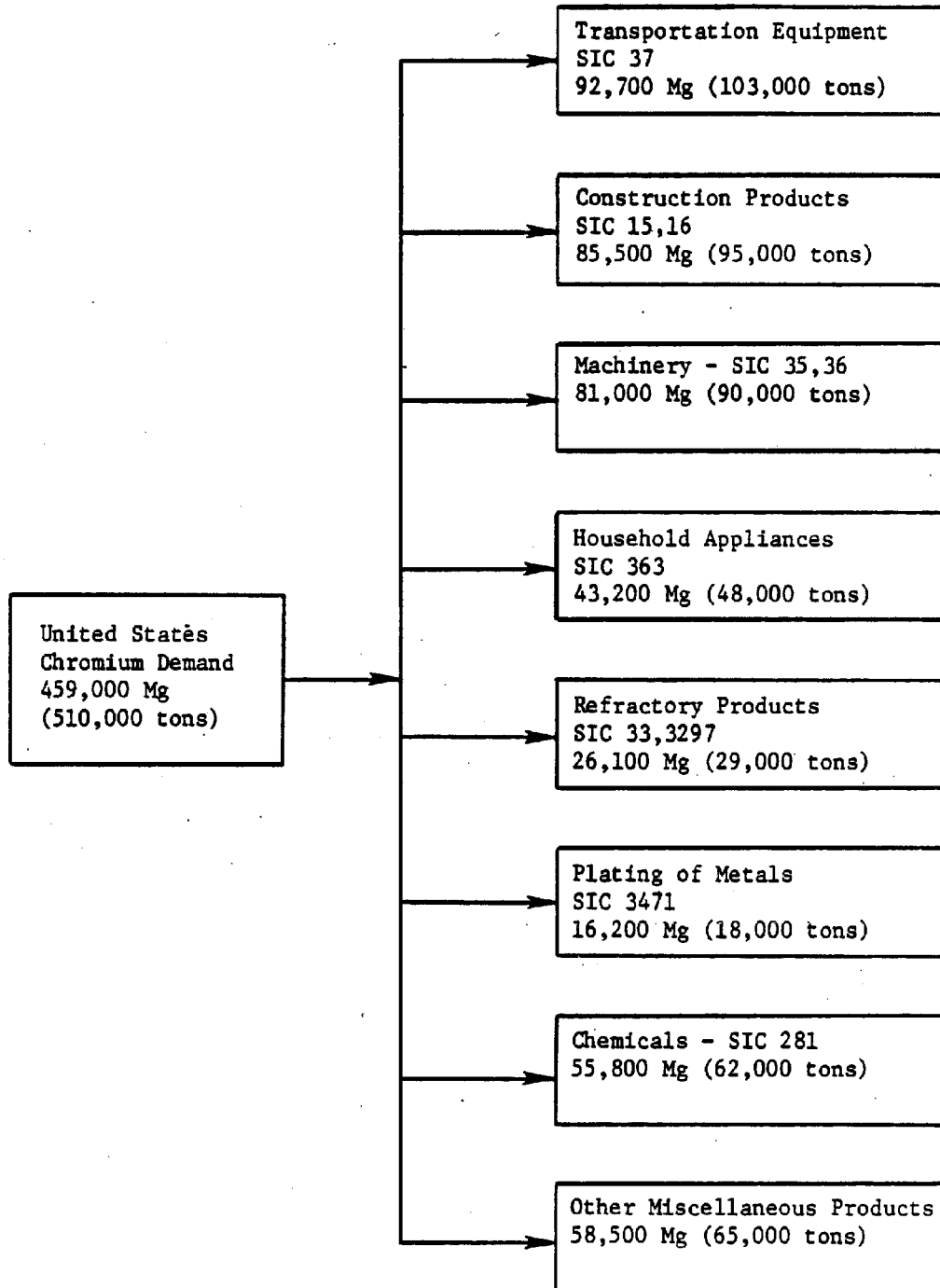

Figure 4. Final consumer use distribution of chromium in the United States in 1981.

Metallurgical Uses--

Chromium's use in the metallurgical industry is to enhance such properties in steels and other alloys as hardenability, creep and impact strengths, and resistance to corrosion, oxidation, wear, and galling (damage by friction or abrasion).⁸ In 1982, 71 percent of the chromium consumed (as ferrochromium) in the metallurgical use group was used in the production of stainless steels. Fifteen percent of the chromium was used to produce full-alloy steels, 3 percent was used for low-alloy and electrical steels, and 2 percent was processed into carbon steels.⁶ The remaining 9 percent was used in a variety of other metallurgical products including cast irons and nonferrous alloys. The chromium steels, alloys, and cast irons produced by the metallurgical industry are used primarily in the manufacture of transportation, electrical, and construction equipment, heavy machinery, and fabricated metal products. Chromium is used in a wide variety of transportation vehicles including automobiles, motorcycles, bicycles, boats, trains, and snowmobiles. Both commercial and military aircraft engines are produced with chromium. Chromium is also used in volume in stainless steel tankers to haul milk, acids, and chemicals, and in bulk hopper trailers to haul fertilizers and hygroscopic materials. In the construction industry, chromium metallurgical products are used for oil and gas exploration and production, petroleum refinery fabrication, power plant sulfur dioxide wet scrubbers, and bridge construction.⁸

In the machinery industry, chromium metals are used to manufacture food processing equipment, high speed machine tools, cutting and forming equipment, and machine tool accessories, including dyes and measuring devices. Chromium use in the fabricated metal products industry covers such products as cutlery, hand tools, general hardware, hospital equipment, and home appliances.⁸ Based on 1981 figures, the combination of transportation, construction, machinery, and household appliance consumer uses of chromium constituted about 66 percent of the total chromium used in the United States (see Figure 4).¹

Chemical Uses--

In the chemical use group, chromium chemicals, primarily sodium chromate and sodium dichromate, are used to manufacture a wide variety of consumer-oriented chromium chemicals and products that have uses in the following areas.

- paints and pigments
- leather tanning liquors
- metal plating and finishing solutions
- corrosion inhibitors
- catalysts
- drilling muds
- wood preservatives
- textile mordants and dyes

A breakdown of the amount of chromium (as sodium dichromate) used in each of the areas given above is shown in Figure 5.¹⁵ Approximately 70 percent of the chromium consumed domestically for chemical uses is accounted for in the preparation of pigment, metal plating, and leather tanning compounds.¹⁵ Chromium pigments are used primarily in paints, inks, and roofing granules. Metal plating solutions, primarily chromic acid, are used in producing decorative automobile trim and appliance exteriors. Chromium leather tanning liquors are the most widely used tanning products, except for the tanning of heavy cattle hides in which vegetable tanning oils are predominant.¹ A list of the key chromium chemicals applied in all the end use areas given above is presented in Table 5.

Refractory Uses--

In the refractory use group, chromium in the form of chromite ore, is used primarily to produce chrome brick, chrome-magnesite brick, and magnesite-chrome brick refractory, which is used to line furnaces, kilns, converters, incinerators, and other high temperature industrial equipment.²⁴ Chromium refractory materials are also used as coatings to close pores and for joining refractory brick within a furnace or

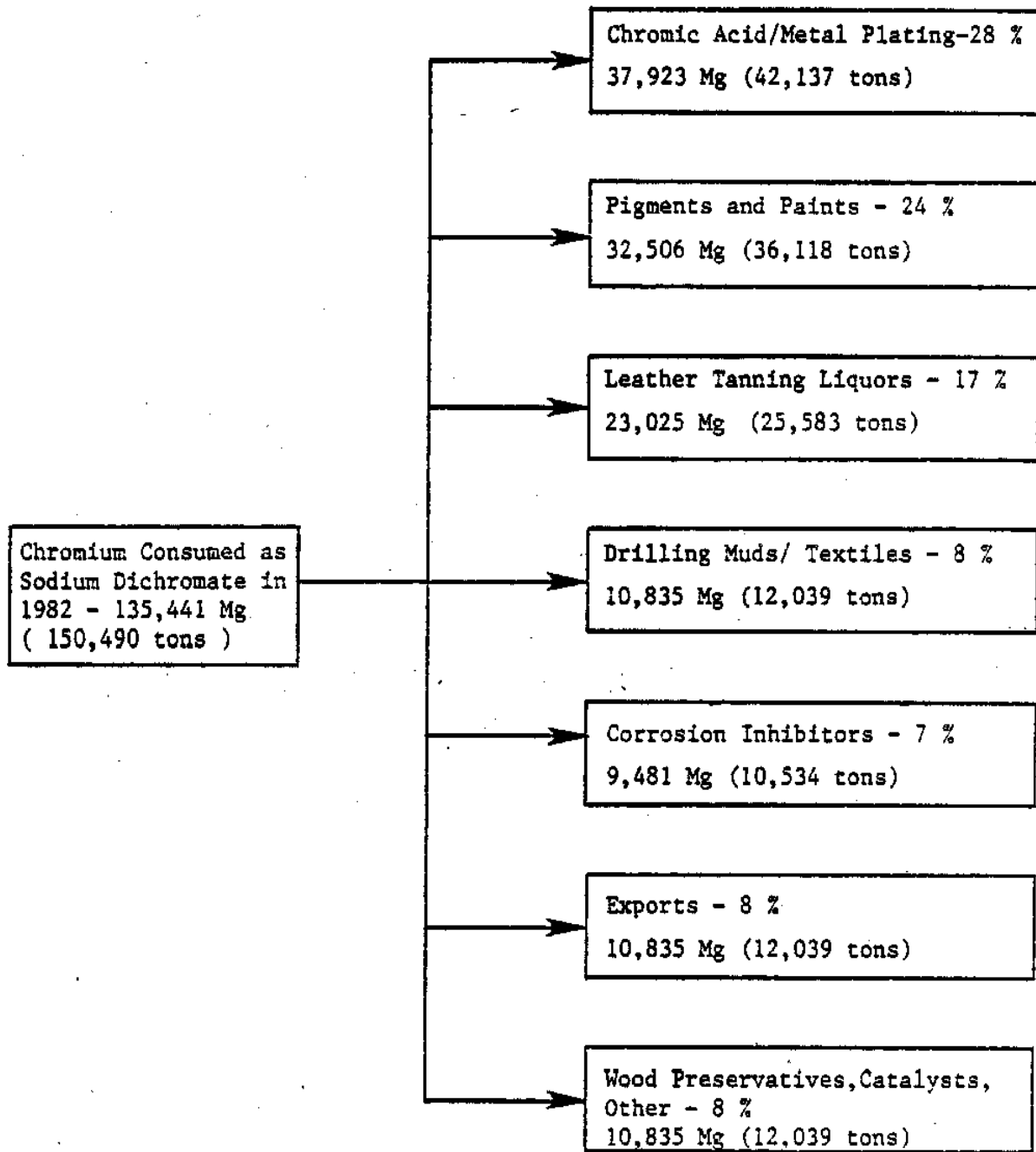

Figure 5. End use tree for sodium dichromate in 1982.¹⁵

TABLE 5. MAJOR CHROMIUM USES AND KEY CHROMIUM CHEMICALS INVOLVED¹

Chromium Chemical Use Area	Key Chromium Chemicals Involved
Paints and Pigments	Chrome Yellows ^a Chrome Orange ^a Chrome Oxide Green Molybdate Orange ^a Chrome Green
Leather Tanning Liquor	Basic Chromium Sulfate
Metal Finishing and Plating	Chromic Acid
Corrosion Inhibitors	Zinc Chromate Zinc Tetroxochromate Strontium Chromate Lithium Chromate
Catalysts	Cadmium Chromate Copper Chromate Magnesium Dichromate Nickel Chromate Copper Chromite
Drilling Muds	Chromium Lignosulfonate
Wood Preservatives	Chrome Copper Arsenate Chrome Zinc Chloride
Textile Mordants and Dyes	Chromic Chromate Chromic Chloride(hydrated) Chromic Fluoride Chromic Lactate

^a Contains lead chromate.

kiln.¹² By far, the major consuming industry for chromitum refractory materials is the iron and steel industry. Other industrial sectors consuming significant amounts of chromium refractory include glass manufacturing, nonferrous metal production, primary minerals smelting, and ceramic production.¹⁹

Chromium (in the form of chromite) consumption in the refractory industry has been declining. From 1977 to 1981 for example, chromite consumption by the refractory industry declined by approximately 37 percent.²³ The increased use of magnesite and a depressed domestic steel industry are the major reasons for the decline in the production of chromium refractory.⁸

REFERENCES FOR SECTION 3

1. Kirk-Othmer Encyclopedia of Chemical Technology. Third Edition. Volume 6. John Wiley & Sons, Inc. New York 1980. pp. 54-120.
2. Sittag, Marshall. (Noyes Data Corp.) Toxic Metals - Pollution - Control and Worker Protection. Noyes Data Corporation. Park Ridge, New Jersey. 1976. pp. 97-131.
3. National Academy of Sciences. Committee on Biologic Effects of Atmospheric Pollutants. Chromium. ISBN 0-309-02217-7. Washington, D.C. 1974. pp. 2-6.
4. Towill, L. E., et al. Reviews of the Environmental Effects of Pollutants: III. Chromium. EPA-600/1-78-023 and ORNL/EIS-80. May 1978. pp. 12-17.
5. National Emissions Inventory of Sources and Emissions of Chromium. (GCA Corporation). EPA-450/3-74-012. May 1973. p. 5.
6. Papp, J. F. (Bureau of Mines). Chromium. Preprint from the 1982 Bureau of Mines Minerals Yearbook. U. S. Bureau of Mines, Washington, D. C. 1983.
7. National Emissions Inventory of Sources and Emissions of Chromium. (GCA Corporation). EPA-450/3-74-012. May 1973. pp. 11-12.
8. Papp, J. F. (Bureau of Mines). Chromium. Mineral Commodity Profiles 1983. U.S. Bureau of Mines. Washington, D.C. 1984.
9. Telecon. Brooks, G.W., Radian Corporation with Watson, G., Ferroalloy Association. February 23, 1983. Ferrochromium plant emissions.
10. Chromium and Chromium Compounds - Phase I Report. Office of Pesticides and Toxic Substances, U.S. Environmental Protection Agency. Washington, D.C. May 1978.
11. National Emissions Inventory of Sources and Emissions of Chromium. (GCA Corporation). EPA-450/3-74-012. May 1973. p. 15.
12. Sullivan, R.J. Preliminary Air Pollution Survey of Chromium and Its Compounds. APTD No. 69-34. U.S. Department of Health, Education, and Welfare. October 1969. pp. 19-20.
13. Proceedings of a Workshop/Conference on the Role of Metals in Carcinogenesis. Atlanta, Georgia. March 24-28, 1980. NIOSH-210-79-0039. Published by the New York University Institute of Environmental Medicine. 1980.
14. SRI International. 1982 Directory of Chemical Producers-United States. Menlo Park, California. 1982. pp. 893-895.

15. Chemical Marketing Reporter. Volume 221, No. 22. May 31, 1982. p. 50.
16. Foley, E. F. Chromium Chemicals Manufacture. (Paper presented at the Symposium on Health Aspects of Chromium Containing Materials. Baltimore, Maryland. September 15, 1977.) Published by the Industrial Health Foundation. 1978.
17. Stern, R. M. Chromium Compounds - Production and Occupational Exposure. The Danish Welding Institute. Glostrup, Denmark. 1982. pp. 4-6.
18. SRI International. 1982 Directory of Chemical Producers-United States. Menlo Park, California. 1982. pp. 36 and 522-523.
19. Refractories. The Refractories Institute. TRI Publication 7901. Pittsburgh, Pennsylvania. 1979.
20. Source Category Survey: Refractory Industry. EPA-450/3-80-006. Emission Standards and Engineering Division, U.S. Environmental Protection Agency. Research Triangle Park, North Carolina. March 1980. pp. 4-16 to 4-25.
21. Product Directory of the Refractories Industry in the United States. The Refractories Institute. Pittsburgh, Pennsylvania. 1978. pp. 21-154.
22. Letter from Olenn, S. F., the Refractories Institute to Lahre, T. F., U. S. EPA. February 27, 1984. Comments on draft chromium report.
23. Snyder, A. D., et al. Environmental Monitoring Nearing Industrial Sites: Chromium. EPA-560/6-77-016. June 1977. p. 5.
24. National Emissions Inventory of Sources and Emissions of Chromium. (GCA Corporation). EPA-450/3-74-012. May 1973. pp. 7 and 14.

SECTION 4

CHROMIUM EMISSION SOURCES

Chromium emission sources can be divided into two broad classes -- direct and indirect. The first part of this section deals with direct chromium emission sources. The direct category primarily includes sources that either produce chromium or consume chromium or a chromium compound to manufacture a product. The source categories within the direct category are:

- chromite ore refining,
- ferrochromium production,
- refractory production,
- chromium chemicals production,
- chromium plating,
- steel production,
- leather tanning.

The second part of the discussion in this section deals with indirect chromium emission sources. Indirect sources are generally those that do not produce chromium or chromium compounds and only inadvertently handle and emit chromium because it is present as an impurity in the feedstock or fuel used in performing their primary activity. For example, during the combustion of fossil fuels to produce energy, chromium is released to the atmosphere because it is a constituent of the fuels burned. The source categories within the inadvertent category are:

- coal and oil combustion,
- cement production,

- municipal refuse and sewage sludge incineration,
- cooling towers,
- asbestos mining and milling, and
- coke ovens.

The following subsections describe the operations of both direct and indirect chromium emission sources and the chromium emission points therein. Where available, chromium emission factors are presented for each source, as well as information on the specific chemical form of chromium in the emissions.

DIRECT SOURCES OF CHROMIUM

Chromite Ore Refining

Process Description--

As discussed in Section 3, no chromite ore is currently being mined in the United States. Also, the current standard practice of foreign chromite mining operations is to clean and size the chromite ore to a customer's specifications prior to export to the United States. This existing ore supply structure largely eliminates the need for a specific domestic chromite ore refining industry. Consequently the domestic chromite ore refining industry is quite small. In 1983, only one plant was known to be operating solely to process and refine chromite ore.^{1,2} Other domestic consuming industries may perform some preliminary grinding and sizing of the ore before it enters their processes.¹

As shown in Figure 6, the chromite ore refining process consists of crushing, drying, and grinding the ore, and packaging it to customer specifications. Ore is first crushed, screened, and dried in a rotary sand dryer.³ It is then conveyed to a Hardinge mill for fine grinding. The fine chromite ore particles are then air conveyed

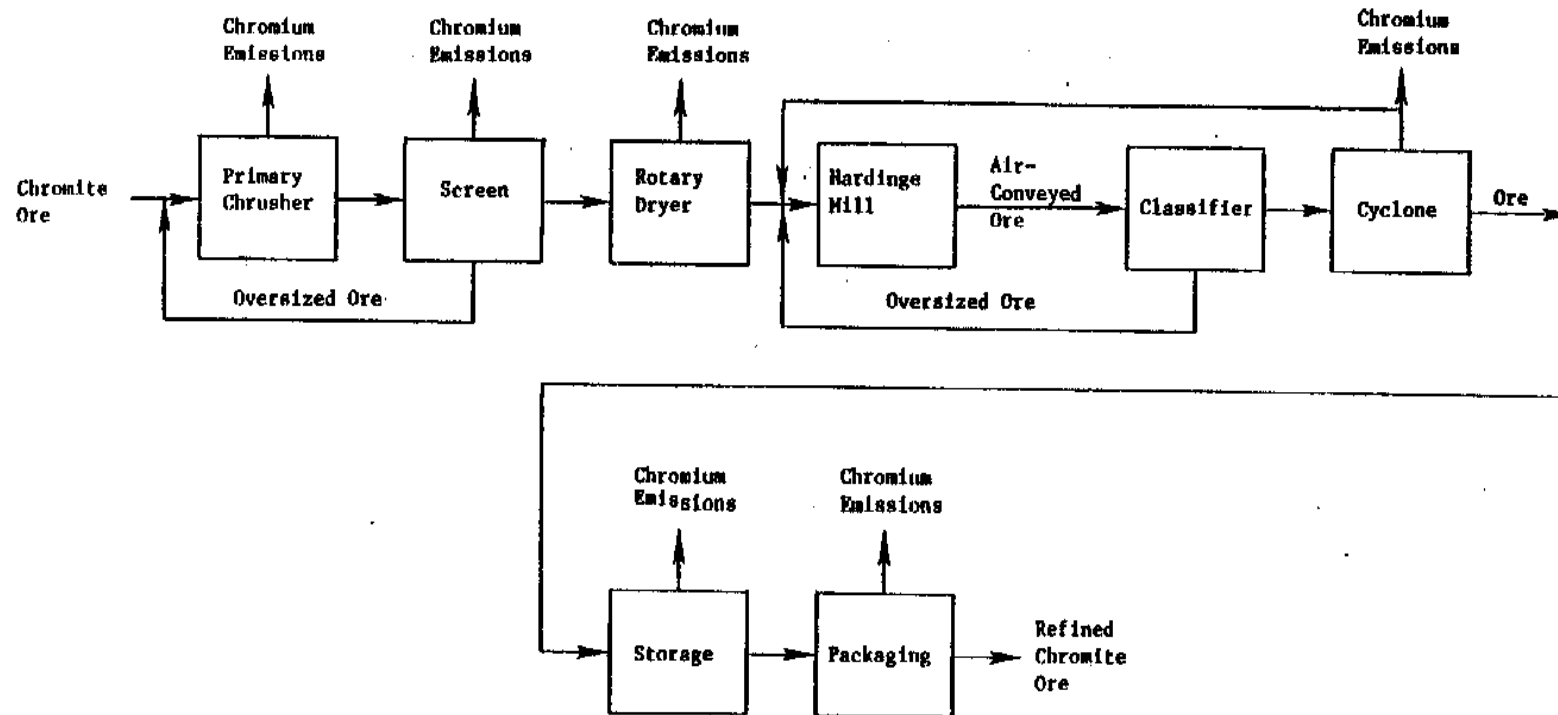

Figure 6. Flow chart for chromite ore refining. 3-5

through a classifier to a cyclone separator. Ore collected in the cyclone is dropped into storage bins and most of the air is recycled to the mill. The refined chromite ore is then packaged in bags.^{4,5}

Emission Factors--

Sources of chromium-containing emissions are indicated on Figure 6. Emissions of chromite ore would occur during primary crushing and screening, however, no data are available on emission rates or control procedures for these steps. Chromite particles are also emitted when ore is dried in the rotary sand dryers. These dryers are equipped with wet scrubbers, which function at greater than 99 percent efficiency.³ The cyclone following the Hardinge mill is another source of chromium emissions. Fine chrome ore particles are pneumatically conveyed from the mill to the cyclone where they are collected. However, the process cyclone is not 100 percent efficient, so some chrome ore particles will be exhausted from the cyclone. Most of the air is recycled to the mill, but some is channeled through a fabric filter and then exhausted to the atmosphere. Fabric filters in this application have been determined to be 99.9 percent efficient.⁴

The storage and packaging of the refined ore are the final sources of chromium emissions. A bin vent dust collector gathers the air and chromite dust displaced from the storage bins as the product is deposited there. Filter cartridges are used to clean this air and are reported to be over 99 percent efficient.⁵

Table 6 shows emission factors for the ore dryer, Hardinge mill and cyclone system, and finished product storage. These factors were calculated from state air quality permit data for the one domestic ore refining plant.³⁻⁵ The permits listed total particulate emission rates as well as throughputs of chromite ore. The emission rates for elemental chromium shown on Table 6 were calculated using the assumptions that chromite ore contains 45 percent chromic oxide (Cr_2O_3),⁶ and that chromic oxide is 68 percent chromium by weight.

TABLE 6. CHROMIUM EMISSION FACTORS FOR CHROMITE ORE REFINING^a

Factor	Control	Chromium Emission	
		kg/Mg(lb/ton) of chromite ore	
Chromite ore dryer	bag collector	.005	(.009)
	wet scrubber	.001	(.002) ^c
Hardinge mill and cyclone	fabric filter	.003	(.005)
Refined ore storage	uncontrolled	.05	(.09)
	dust collector	.00005	(.00009)
	filter cartridge)		

^a Emission factors calculated as described in test from References 3, 4, and 5.

^b All emission factors reported as total elemental chromium. Chromium exists in the emissions as trivalent chromium.

^c Factor assumes 99.9 percent control efficiency

Source Locations--

The only known chromite ore refining plant in the United States in 1983 was the American Minerals, Inc. Plant in New Castle, Delaware.²

Ferrochromium Production

Process Description--

Ferroalloys are crude alloys of iron and one or more other elements which are used for deoxidizing molten steels and making alloy steels.⁷ Chromium is a component of about 16 percent of domestically produced ferroalloys.⁸ Types of chromium ferroalloys (ferrochromium) include high-carbon ferrochrome, low-carbon ferrochrome, charge chrome, ferrochrome-silicon, and other lower volume products.^{8,9} Chromium ferroalloys can be produced by four different processes. The primary method of producing high-carbon ferrochrome, ferrochrome-silicon, and charge chrome is in an electric arc furnace. Low carbon-ferrochrome can be produced by either an exothermic process or vacuum furnace process, and chromium metal can

be produced by an exothermic or electrolytic process.^{8,9} All four types of processes have been used in the past, but only the electric arc furnace process is currently used in the United States.¹⁰

In 1980, there were seven plants manufacturing ferrochromium.⁸ However in the first quarter of 1983, only one plant was actively producing ferrochromium.¹⁰ Other plants suspended production of ferrochromium due to low demand brought on by a depressed steel industry and the ability of the steel industry to obtain its ferrochromium requirements more cheaply from foreign sources. The Ferroalloy Association estimated that in early 1983, 95 percent of the ferrochromium consumed in the United States was imported.¹⁰ The increase in ferrochromium imports and resulting decline in domestic production is attributable to a trend in chromite-producing countries to do more processing of the chromite ore into ferrochromium and other products before shipment. Less raw chromite ore is therefore available to be shipped to the United States. Lower labor, energy, and transportation costs allow the chromite-producing countries to sell their ferrochromium at lower prices than domestic ferrochromium companies can. Changes or upturns in the domestic steel industry could alter the demand for ferrochromium and bring domestic ferrochromium plants back on line.¹⁰

The electric arc furnace method of ferrochrome production is pictured in Figure 7. Chromite ore and other necessary raw materials are brought to the plant by truck or rail and stored in a stockpile (Figure 7, point 1). Depending on weather conditions and its moisture content, the chromite ore may need to be dried (point 2) before being crushed (point 3), sized (point 4), and mixed with other raw materials to meet process specifications. The charge (raw materials) is then weighed and fed to a submerged electric arc furnace (point 5) for smelting (point 6)^{8,9,11}

Three types of electric arc furnaces can be used. These are open, sealed, and semisealed furnaces^{7,8} The operations of each type of furnace are discussed in succeeding paragraphs. Electric arc furnaces may be continuously or intermittently charged with chrome

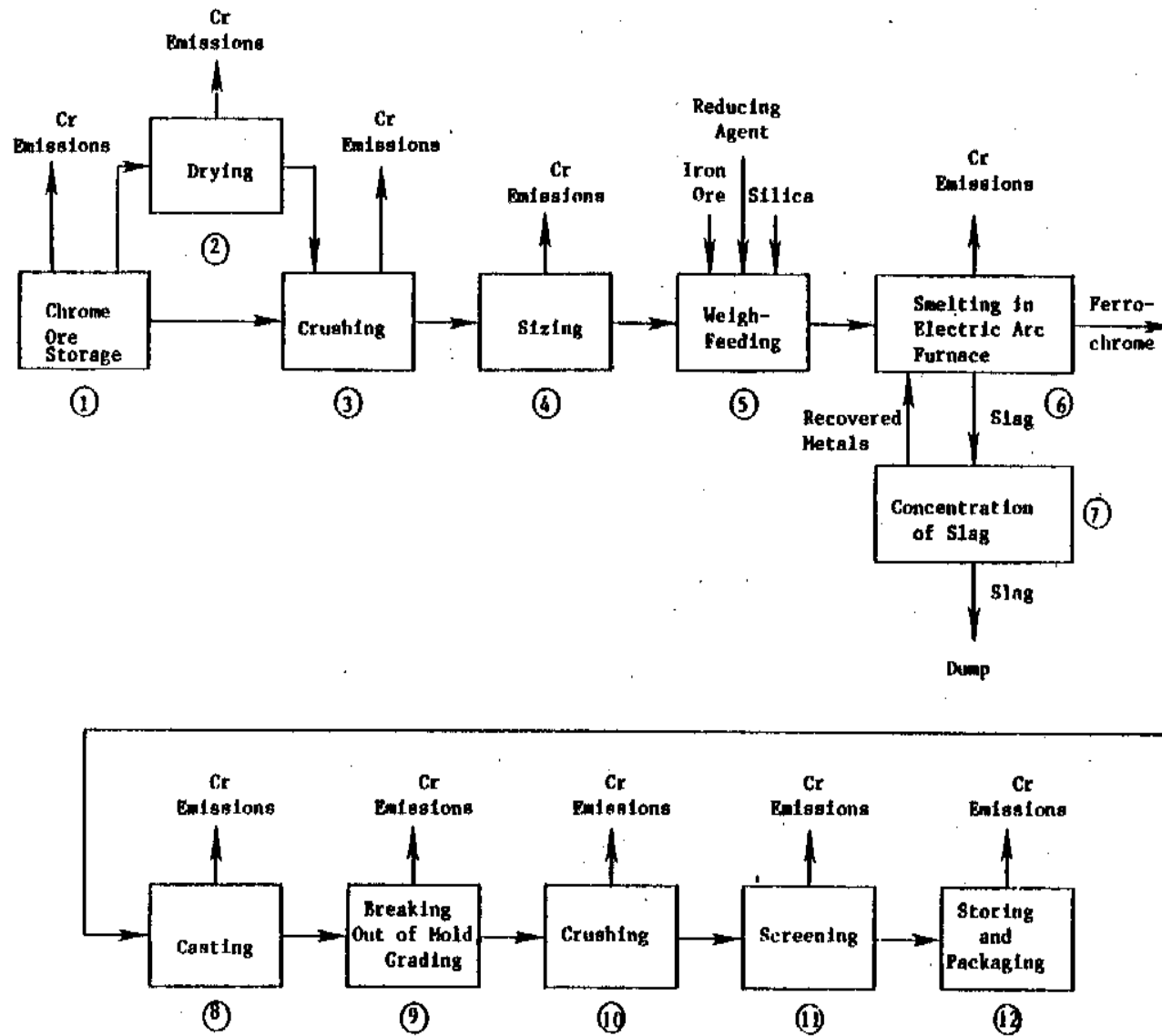

Figure 7. Flow chart of ferrochrome production by the electric arc furnace process.

and iron ores, a reducing agent such as alumina, coal, and/or coke, and slagging materials such as silica or gravel. Three carbon electrodes are vertically suspended above the hearth, and extend 1 to 1.5 m (3 to 5 ft) into the charge materials. Three-phase current arcs through the materials from electrode to electrode, and the charge is smelted as electrical energy is converted to heat. The intense heat around the electrodes (2204-2760°C or 4000-5000°F) results in carbon reduction of the chrome and iron oxides in the charge and the formation of ferrochromium. The molten ferrochromium is periodically tapped into ladles from tapholes in the lower furnace wall.^{8,11}

The molten ferrochrome is cast into molds and allowed to cool and solidify (point 8, Figure 7). The casts are then removed from the molds, graded and broken (point 9, Figure 7). The broken ferrochromium is passed through a crusher and screened (points 10 and 11, Figure 7). The ferrochrome product is then stored, packaged (point 12, Figure 7), and shipped to the consumer.^{8,11}

Impurities from the smelting process are trapped in a slag which forms inside the electric arc furnace. The slag is periodically tapped and treated by a concentration process (point 7, Figure 7) to recover metal values. Slag is processed in a flotation system, where metal particles including chromium sink to the bottom while slag floats. The recovered metals are recycled to the furnace, and the remaining slag is removed and disposed of.¹¹

As previously stated, open, sealed, and semisealed furnaces may be used to produce ferrochromium by the electric arc process. Open furnaces are the most common type, and also have the highest potential for chromium-containing particulate emissions. An open furnace is pictured in Figure 8.⁷ A hood is usually located 1.8 to 2.4 m (6 to 8 ft) above the furnace crucible rim. Dust and fumes from the smelting process are drawn into the hood along with large volumes of ambient air. Advantages of the open furnace include the ability to stoke it

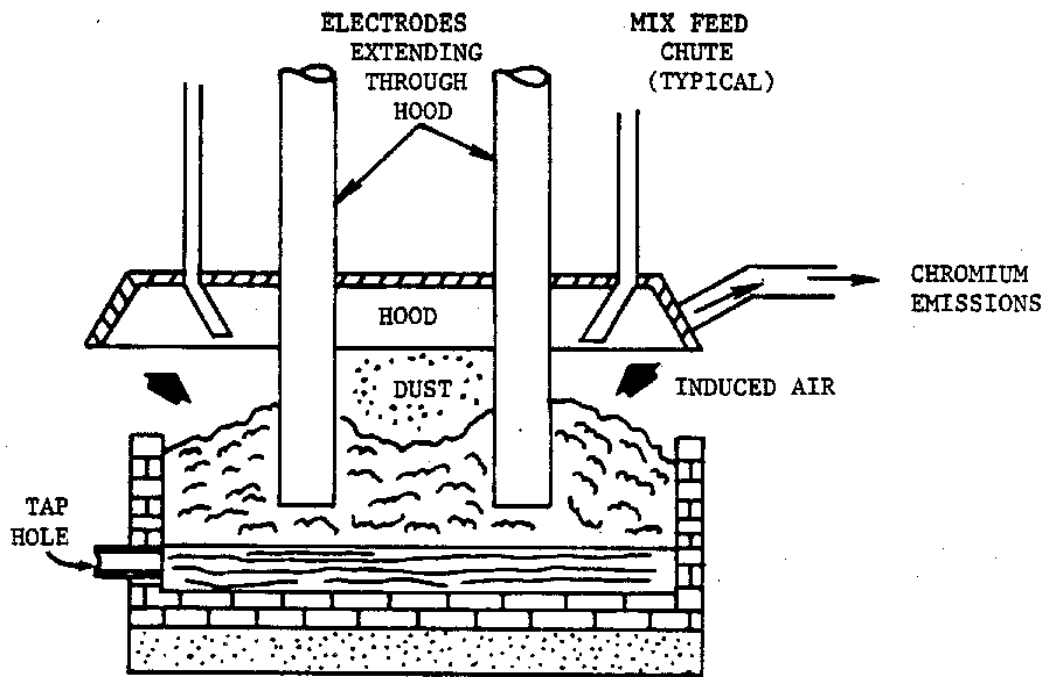

Figure 8. Open electric arc furnace.⁷

during operation and the flexibility to manufacture several types of ferroalloy without altering the furnace design. Claims have also been made that open furnace operations have fewer accidents and greater worker safety than sealed furnace operations.⁷

The semisealed (or semi-enclosed) furnace is pictured in Figure 9. A cover seals the top of the furnace except for openings around the electrodes through which raw material is charged. These furnaces are either hooded or maintained under negative pressure to collect emissions from around the electrodes. Semisealed furnaces can be used to produce some chromium-containing ferroalloys, but problems occur in the production of high-silicon grades of ferrochrome because of the inability to stoke the furnace. Without stoking, crusting and bridging of ferroalloys around the electrodes and charge holes may prevent uniform descent of the charge into the furnace and blows (jets of extremely hot gasses originating in the high temperature zone near the electrode tips) may emerge around the electrodes at high velocity.⁷

The third type of electric arc furnace; the sealed or closed furnace, is illustrated in Figure 10.⁷ Packing is used to seal the cover around the electrodes and charging chutes. The furnace is not stoked and a slight positive pressure is maintained to prevent leakage of air into the furnace. High-silicon ferrochrome and high-carbon ferrochrome are rarely produced in sealed furnaces due to crusting and bridging and the possibility of blows. Care must also be taken to prevent water leaks which may cause explosive gas release which could damage the furnace and threaten worker safety. Sealed furnace designs are specifically used in the manufacture of narrow families of ferroalloys, so plants using sealed furnaces have less flexibility to produce different types of ferroalloys.⁷ Ferrochromium has not been produced in sealed furnaces in the United States, however it has been produced this way in Japan.⁸

A recent innovation in sealed furnaces is the split-furnace design, in which the upper ring of the furnace rotates more rapidly than the lower furnace. This has a mixing effect on the furnace

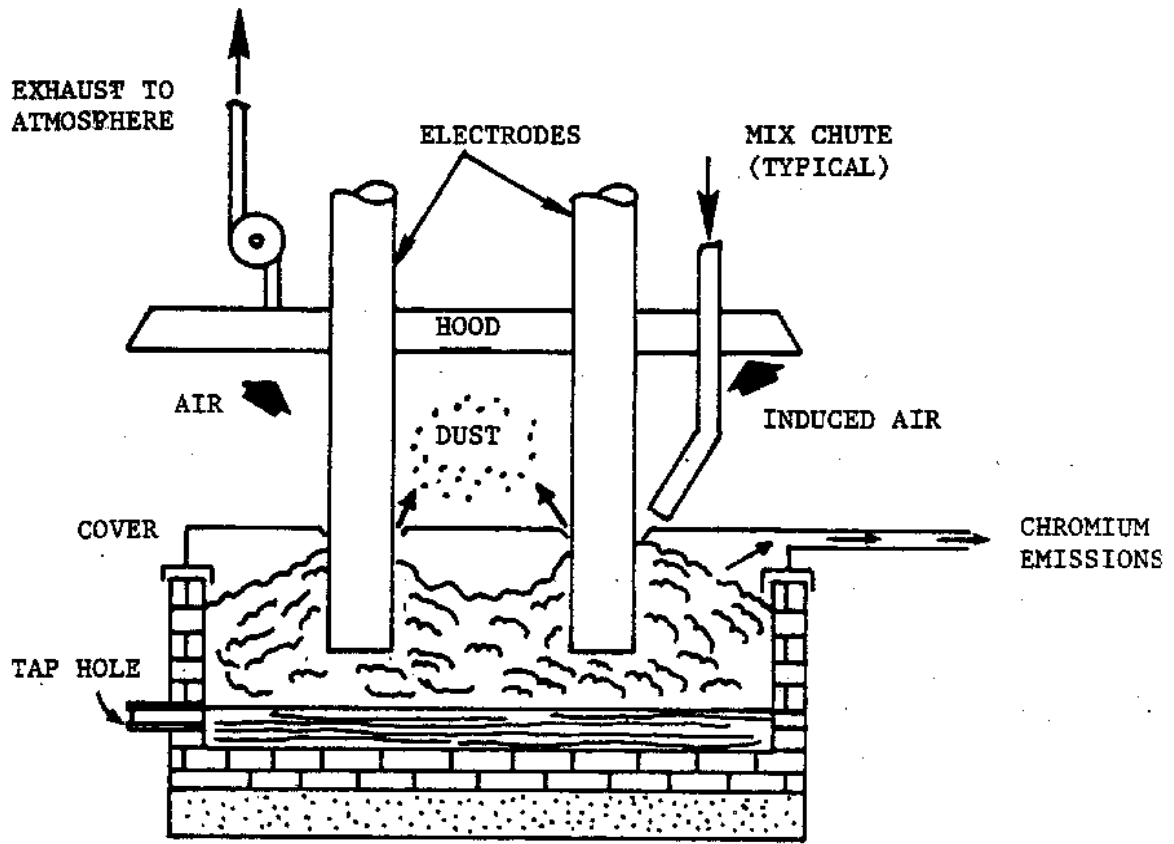

Figure 9. Semisealed electric arc furnace.⁷

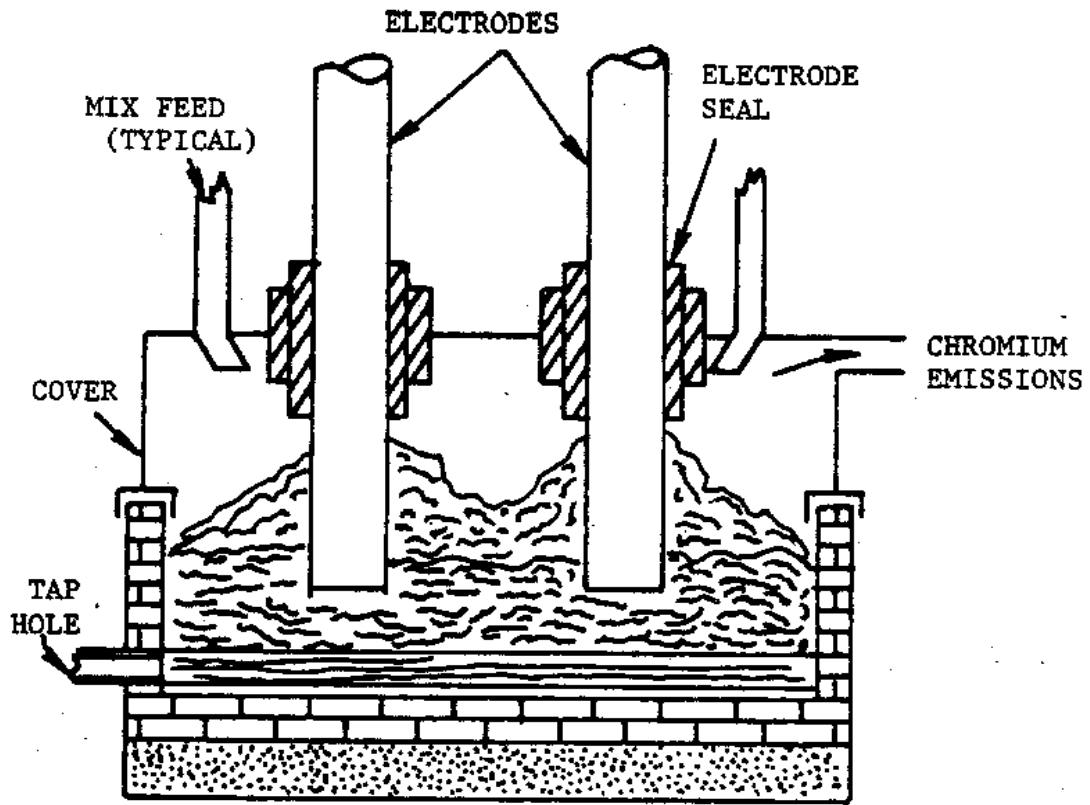

Figure 10. Sealed electric arc furnace.⁷

contents and reduces crusting and bridging problems. Another method used to provide mixing is the insertion of stoking devices through seals in the furnace walls. Use of these techniques, which are practiced in Japan and Norway, makes possible the production of high-silicon ferrochrome and high-carbon ferrochrome in sealed furnaces.⁸

One alternative to the electric arc furnace process which can be used to produce low-carbon ferrochrome is a type of exothermic process involving silicon reduction. A flow diagram of the process is shown in Figure 11. First chromium ore and lime are fused together in a furnace to produce a chrome ore/lime melt which is poured into a reaction ladle (number 1). Then a known quantity of molten ferrochrome silicon previously produced in another reaction ladle (number 2) is added to ladle 1. In the ladle, a rapid heat-producing reaction results in the reduction of the chromium from its oxide form and the formation of low-carbon ferrochrome and a calcium silicate slag. The ferrochrome product is then cooled, finished, and packaged. Since the slag from ladle 1 still contains recoverable chromium oxide, it is reacted in ladle 2 with molten ferrochrome-silicon produced in a submerged arc furnace. The exothermic reaction in ladle 2 produces the ferrochrome-silicon added to the number 1 ladle during the next production cycle.⁹

A vacuum furnace process can also be used to produce low-carbon ferrochrome. The furnace, pictured in Figure 12, is charged with high-carbon ferrochrome and heated to a temperature near the melting point of the alloy. Decarburization occurs as the high-carbon ferrochrome is oxidized by the silica oxide in the ferrochrome. Carbon monoxide gas resulting from the reaction is pumped out of the furnace to maintain a high vacuum and promote decarburization of the ferrochrome.⁹

The electrolytic process is another alternative to the electric arc furnace for producing chromium ferroalloys. Pure chromium metal is generally produced this way. Chromite ore, high-chromic oxide

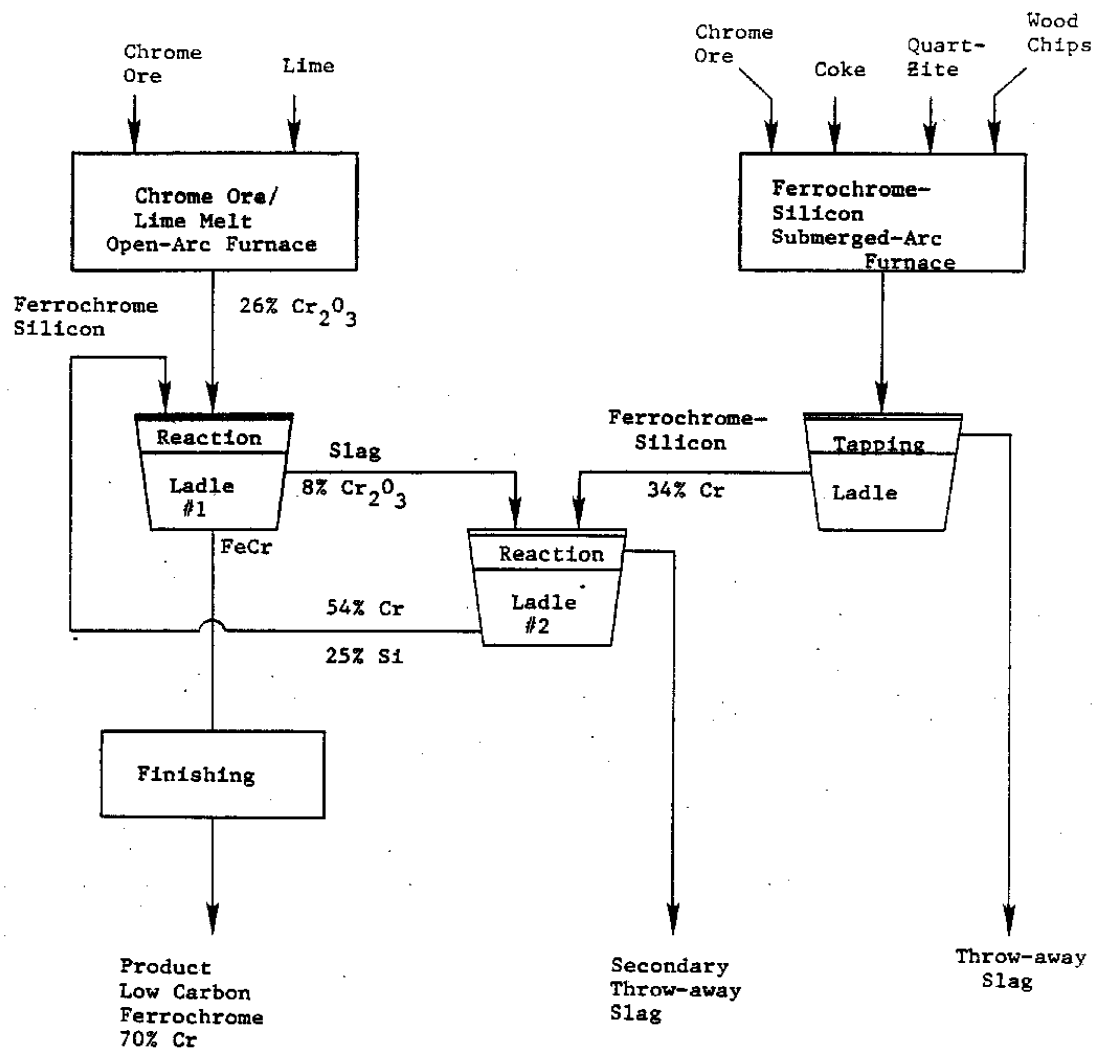

Figure 11. Typical flow chart for the production of low-carbon ferrochrome by the exothermic silicon reduction process.⁹

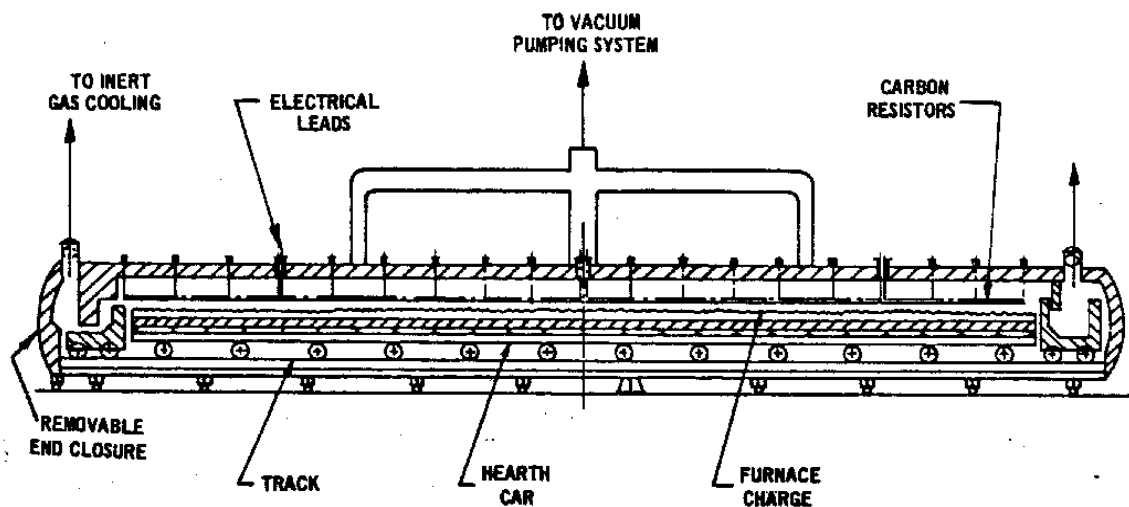

Figure 12. Vacuum furnace for the production of low-carbon ferrochrome.⁹

slags, or ferrochrome can be used as raw materials for the process. Preparation of raw materials can include grinding, calcining and leaching. In the electrolytic process, chromium ions contained in an electrolytic solution are plated on cathodes by a low voltage direct current. The pure chrome forms a film on the cathode about 0.3 cm (1/8 in.) thick, which is removed and prepared for shipment.⁹

Emission Factors--

Figure 7 shows possible sources of chromium emissions from the production of chromium ferroalloys by the electric arc furnace process. Depositing and removing materials from the chrome ore stockpile and wind erosion of the stockpile result in emissions of chromite particulates. To reduce emissions, storage piles can be sheltered by walls, covered with plastic, or sprayed with water. The extent of such practices is unknown. Drying, crushing, screening, and other chrome ore pretreatment steps also produces chromium emissions. Scrubbers, cyclones, and fabric filters typically control emissions from these operations, and are reported to be 90 to 99 percent effective for removal of chromium-containing particulates.⁹

The smelting of chrome ore and other raw materials in the electric arc furnace is the major source of chromium emissions in a ferrochromium plant. All three types of electric arc furnaces (open, sealed, and semisealed) emit carbon monoxide and other gasses. Chromium-containing particulates are entrained as this gas evolves and as ambient air passes over the charge materials. Open furnaces have the highest uncontrolled chromium emissions because the large opening between the furnace rim and hood allows more circulation of air and gasses through the charge material which entrains chrome and other particulates. Fumes and particulates may escape if adequate draft is not maintained in the collection hood.^{7,8}

Fabric filters were used to control emissions from 87 percent of the open-arc ferroalloy furnaces operating in 1980.^{8,12} Testing of these control systems indicates total particulate removal efficiency of over 99 percent.⁸ Testing of fabric filters on combustion sources indicates that they are as effective at controlling chromium as they

are at controlling total particulates.¹³ Data from one ferrochromium plant support this finding.⁹

High pressure-drop venturi scrubbers and electrostatic precipitators have also been applied to open-arc furnaces producing ferrochromium alloys, but these plants have recently shut down. Reported particulate collection efficiencies for scrubbers ranged from 94 to 98 percent. When ESPs were used, the gas was conditioned with ammonia to enhance particulate resistivity and increase collection efficiency.^{7,8} Estimated particulate removal efficiencies were 98 percent.⁹ There are little data from the ferrochromium industry on chromium collection efficiencies of scrubbers and ESPs. However, testing of similar high-temperature processes at combustion sources indicated that these devices control chromium to about the same degree as total particulates.¹³

In the case of semisealed furnaces (Figure 9), offgases and entrained chromium-containing particulates are drawn from beneath the cover through ducts leading to the control device. However, fugitive chromium particulates and fumes escape through the openings around the electrodes. Hoods can be placed above the furnaces to entrap these emissions. Wet scrubbers, including both multistage centrifugal scrubbers and venturi scrubbers, have been used on semisealed ferroalloy furnaces. Up to 99 percent particulate removal efficiency is reported for centrifugal scrubbers, and venturi types are more efficient. Fabric filters and ESPs are not known to be used on semisealed furnaces.⁷

Because no air enters sealed furnaces (Figure 10), gas volumes to the control device are only 2 to 5 percent of those from open furnaces. This results in a much smaller mass of entrained chromium-containing particulates. Venturi scrubbers are commonly used to control particulates, and therefore chromium emissions, from sealed furnaces, including one furnace which produced charge chrome but is now shut down. Fabric filters have been used at a few sealed

furnaces for particulate emissions control.⁸

Another source of emissions from all three types of electric arc furnaces is the tapping of molten ferrochrome from the furnace into a ladle. Tapping takes place during 10-15 percent of the furnace operating time. Hood systems are sometimes installed over the tapping hole and ladle to capture and direct the chromium-containing emissions to a fabric filter or scrubber.^{7,8}

Additional chromium emissions from ferrochromium plants occur as the ferrochromium product is finished and riandled. After smelting and tapping, the ferrochromium is cast. Chromium-containing particulates and fumes escape as the molten ferrochromium is poured into molds. Casting operations may be hooded, but emissions from casting are uncontrolled at many ferroalloy plants.⁹ Other sources of chromium emissions include the final crushing, sizing, and packaging of the ferrochromium product. The majority of plants control these operations with fabric filters or scrubbers.⁹

There is little information on chromium emissions or controls for the production of ferrochrome by exothermic, vacuum furnace, or electrolytic processes; Sources of particulate chromium emissions from the exothermic silicon reduction process (Figure 11) would include the electric arc furnaces used to manufacture the chrome ore/lime melt and the ferrochrome silicon as well as the tapping ladle and the two reaction ladles. The silicon reduction occurring in the reaction ladles causes a rise in temperature and strong agitation of the molten ferrochrome for about five minutes per production cycle. During this agitation, gases and entrained chromium-containing particulates are emitted.⁹ Only one plant manufactured ferrochromium using an exothermic process in 1980.⁸ According to the Ferroalloy Association, it is not currently active.¹⁰ No information on typical control technologies is available.

Vacuum furnaces used to produce ferrochrome (Figure 12) emit only trace quantities of particulates,⁹ and none are currently

operative in this country. Electrolytic processes used to produce chrome metals do not emit particulates. However, chromium ions in the electrolyte solution can be emitted in a mist which is released from the tank when hydrogen and oxygen are evolved around the anode and cathode. The extent to which electrolytic process emissions are controlled is unknown. The one plant which was operating in 1980⁸ is currently inactive.¹⁰

Chromium emissions factors for the electric arc furnace method of ferrochrome production can be calculated from data available in the literature. A 1974 U.S. EPA study estimated particulate emissions from raw materials handling and processing at sixteen electric arc furnace ferroalloy plants.⁹ The specific types of ferroalloys these plants produced were not specified. However, it was assumed that since raw materials handling procedures are similar for chrome-containing and non chrome-containing ferroalloy production, total particulate emissions factors for general ferroalloy production would apply to the production of chrome ferroalloys. To derive chromium emission factors from total particulate emission factors, it was assumed that metallurgical grade chrome ore (a raw material for ferrochrome production) contains 50 percent chromic oxide¹⁴ and that elemental chrome is 68 percent of chromic oxide by weight. Chromium emission factors for raw materials processing steps are expressed in Table 7 in terms of pounds of chromium emitted per ton of chrome ore processed.

The 1974 U.S. EPA report cited above also listed particulate emissions from handling and finishing of the ferroalloy products including casting, crushing, and grinding.⁹ The chromium content of particulate emissions would vary depending on the chromium content of the ferroalloy being produced. The composition of chrome ferroalloys can range from 36 percent chromium for ferrochrome-silicon to 70 percent chromium for charge chrome and high-carbon ferrochrome.¹⁴

TABLE 7. CHROMIUM EMISSION FACTORS FROM PROCESSING OF RAW MATERIALS AT FERROCHROME PLANTS

Emission Source	Chromium Emission Factor ^{a,b} g/kg (lb/ton) of Chrome Ore Processed
Receipt and Storage of Chrome Ore in Stock pile. ^c	.34 (.68)
Drying, Crushing, and Sizing of Chrome Ore. ^d	.34 (.68)
Weighing and Feeding Chrome Ore to Electric Arc Furnace ^e	.31 (.61)

^a Emission factors expressed in terms of total elemental chromium. Emissions should contain chromium in predominantly the trivalent oxidation state.

^b These factors are a composite of both controlled and uncontrolled emissions sources. The percentage of controlled and uncontrolled sources used in determining the composite factors is given in footnotes c, d, and e. The degree of control in each case is unspecified.

^c Only 15 percent of the sources used to determine this composite factor were controlled.

^d Approximately 75 percent of the sources used to determine this composite factor were controlled.

^e 20 percent of the sources used to determine this composite factor were controlled.

The chromium emission factors for ferrochrome-silicon and high-carbon ferrochrome in Table 8 were obtained by multiplying average total particulate emissions from finishing and handling ferroalloy products by 36 and 70 percent, respectively.

Electric arc furnaces are the most researched source of chromium emissions in the ferrochrome manufacturing process. Table 9 gives emission factors for ferrochrome producing furnaces expressed in term of chromium emitted per ton of product and chromium emitted per megawatt hour of furnace operation. Uncontrolled emission factors are based on estimates of total particulate emissions made by industry personnel at three plants and reported in a 1974 U.S. EPA report.⁹ The total particulate emission factors were multiplied by the measured average percent chromium in particulate emissions at similar furnaces producing the same types of ferrochrome.⁹ Most of the controlled chromium emission factors were based on EPA tests of total particulate emissions. These were again multiplied by the measured typical percent chromium in particulate emissions from ferrochrome furnaces.^{9,11,15} If different particulate collection devices collect chromium to a greater or lesser extent than they collect other particulates in the emission stream, the calculated chromium factors for controlled sources could be biased. Data on chromium collection efficiency for the ferrochromium industry is inconclusive. But as previously stated, data from similar high-temperature processes involving chromium (including power plants) show that chromium is collected in a similar proportion to other particulates.¹³ As Table 9 illustrates, chromium emission factors vary with the type of ferrochrome produced and the type of emissions control system.

No chromium emission factors are available for the exothermic, vacuum furnace, or electrolytic methods of ferrochrome production.

Source Locations--

The only ferrochromium plant currently in operation is the Interlake, Inc., plant in Ohio.¹⁰ Seven plants were in operation as recently as 1980,⁸ but have been shut down for reasons previously

TABLE 8. CHROMIUM EMISSION FACTORS FROM FINISHING OPERATIONS AND PRODUCT HANDLING AT FERROCHROME PLANTS

Emission Source	Chromium Emission Factors ^{a,b} g/kg (lb/ton) of Product	
	Ferrochrome-Silicon	High-Carbon Ferrochrome
Treatment of Molten Alloy with Chlorine or Other Gas in Ladle ^c	1.7 (3.4)	3.3 (6.6)
Casting of Ferrochrome Product ^d	0.36 (.072)	.070 (.14)
Crushing/Grinding of Product ^e	.11 (.22)	.21 (.42)

^a Emission factors expressed in terms of total elemental chromium. Emissions should contain chromium in both trivalent and hexavalent oxidation states.

^b These factors are a composite of both controlled and uncontrolled emissions sources. The percentage of controlled and uncontrolled sources used in determining the composite factors is given in footnotes c, d, and e. The degree of control in each case is unspecified.

^c Only 25 percent of the sources used to determine this composite factor were controlled.

^d Approximately 42 percent of the sources used to determine this composite factor were controlled.

^e 93 percent of the sources used to determine this composite factor were controlled.

TABLE 9. CHROMIUM EMISSION FACTORS FOR ELECTRIC ARC FURNACES USED TO PRODUCE FERROCHROMES. ^{3,5,8}

Ferrochrome Product	Chromium Emission Factors ^a	
	kg/Mg (lb/ton) of product	kg/Mw (lb/Mw hr)
<u>Uncontrolled Sources</u>		
Ferrochrome-Silicon	1.6-5.8	(3.3-12) ^f .20-.78 (.45-1.6) ^f
High-Carbon Ferrochrome and Charge Chrome	24(47)g	3.9 (8.7) ^g
Chrome Ore/Lime Melt	0.8 (1.6) ^h	.63 (1.4) ^h
<u>Controlled Sources</u>		
Ferrochrome-Silicon ^b	-	.0034 (.0076) ⁱ
Ferrochrome-Silicon ^c	-	.00081 (.0018) ⁱ
Ferrochrome-Silicon ^c	.006 (.012) ⁱ	.00076 (.0017) ⁱ
Ferrochrome-Silicon ^d	-	.00002 (.00004) ⁱ
High-Carbon Ferrochrome and Charge Chrome ^b	-	.06 (.15) ^g
High-Carbon Ferrochrome ^c	-	.0022 (.0049) ^g
High-Carbon Ferrochrome ^e	-	.041 (.091) ^g
High-Carbon Ferrochrome ^e	.19 (38) ^g	.040 (.090) ^g
High-Carbon Ferrochrome ^c	-	.020 (.045) ^g

^a All factors expressed in terms of total elemental chromium. Emissions should contain chromium in both trivalent and hexavalent oxidation states.

^b Open furnace controlled with a scrubber.

^c Open furnace controlled with fabric filter.

^d Closed furnace in Japan controlled with a scrubber.

^e Open furnace controlled with an ESP.

^f Assumes chromium is 0.4 to 1.4 percent of total particulate emissions by weight.³

^g Assumes chromium is 14 percent of total particulate emissions by weight.³

^h Assumes chromium is 15 percent of total particulate emissions by weight.³

ⁱ Assumes chromium is 0.4 percent of total controlled particulate emissions by weight.³

described. A change in demand could potentially cause these plants to be reopened, so they are listed in Table 10. The trade group known as the Ferroalloy Association is the best source of current information on the industry.

Refractory Manufacture

Process Description--

Refractories are heat-resistant materials which are used to build or line high-temperature industrial furnaces. They must withstand excessive thermal stress, physical wear, and corrosion by chemical agents.^{16,17} Several hundred types of refractory products are manufactured in the United States, but not all contain chromium. Chromium-containing refractories come in several different forms and compositions depending on the end use for which they are intended.

Chromium is used primarily in the manufacture of chemically basic, non-clay refractories, of which magnesia-chrome combinations are the most prevalent. Magnesia-chrome refractories exhibit good mechanical strength and volume stability in high temperature applications. The chromium components of these refractories are effective in reducing refractory flaking and cracking (spalling) under the fluctuating temperatures often encountered in industrial furnaces. Magnesia-chrome refractories are also used because of their ability to resist corrosion by chemically basic slags. Production furnaces in the steel, copper, cement, and glass industries make use of this type of refractory.^{16,17}

A second type of basic chromium refractory is known as chrome-magnesite. Chrome-magnesite is very similar to magnesia-chrome except that it contains a larger proportion of chromium, which causes it to expand less when subjected to intense heat. Chrome-magnesite refractories are used in the steel, glass, and non-ferrous metals industries.^{16,17}

TABLE 10. LOCATION OF PLANTS PRODUCING CHROMIUM
FERROALLOYS AS OF 1980²

Producer	Plant Location	Process
Chromasco, Ltd.	Woodstock, TN	Electric Arc Furnace
Interlake, Inc. ^a	Beverly, OH	Electric Arc Furnace
MacAlloy Corp.	Charleston, SC	Electric Arc Furnace
Metallburg, Inc.	Newfield, NJ	Exothermic
Satra Corp.	Steubenville, OH	Electric Arc Furnace
SKW Alloys, Inc.	Calvert City, KY	Electric Arc Furnace
Union Carbide Corp.	Marietta, OH	Electrolytic

^a Only plant operating as of 1983.

Note: This listing is subject to change as market conditions change, facility ownership changes, plants are closed down, etc. The reader should verify the existence of particular facilities by consulting current listings and/or the plants themselves. The level of chromium emissions from any given facility is a function of variables such as capacity, throughput, and control measures. It should be determined through direct contacts with plant personnel.

Chromic oxide refractories are a third type of chemically basic refractory, which contain only chromic oxide. They are used primarily in furnaces in the steel and copper industries, but also have other specialty uses.^{16,17}

A fourth type of chromium-containing refractory is chrome-alumina. These alumina-containing refractories exhibit good volume stability at extremely high temperatures. They have specific applications in the steel and other industries such as synfuels and coal gasifiers.^{17,18}

Chromium refractory material is manufactured as pre-formed bricks and shapes and as unformed granulated or plastic compositions. Pre-formed bricks and shapes are made into many sizes and configurations, and not just standard rectangular bricks, to fit whatever the end-use application may be. Unformed refractory compositions include products such as mortars, plastics and gunning mixes, and castables which harden in place after being mixed with water and applied. These unformed compositions are often used to line and seal furnaces, or to repair furnaces in which refractory bricks have broken or deteriorated.^{16,17}

Because of the many different forms, compositions, and end uses of chromium-containing refractories, there are many variations on the refractory manufacturing process. This report gives a general overview of the manufacture of chromium-containing basic brick, chrome oxide brick, and unformed chromium refractories. Figure 13, Figure 14, and Figure 15 illustrate these general manufacturing processes. It is important to recognize that there is a distinction between refractory production using chrome ore and production using chromic oxide. Chrome ore is mined and used in refractories in the same chemical form as it exists in nature. Chromic oxide is chemically derived from separate processes and refractory production using it are quite different from those employing chrome ore.¹⁸ The production of chromium refractory materials can contain from one to four general operations, depending on the type being produced. These operations include raw materials processing, forming, firing, and final product preparation.

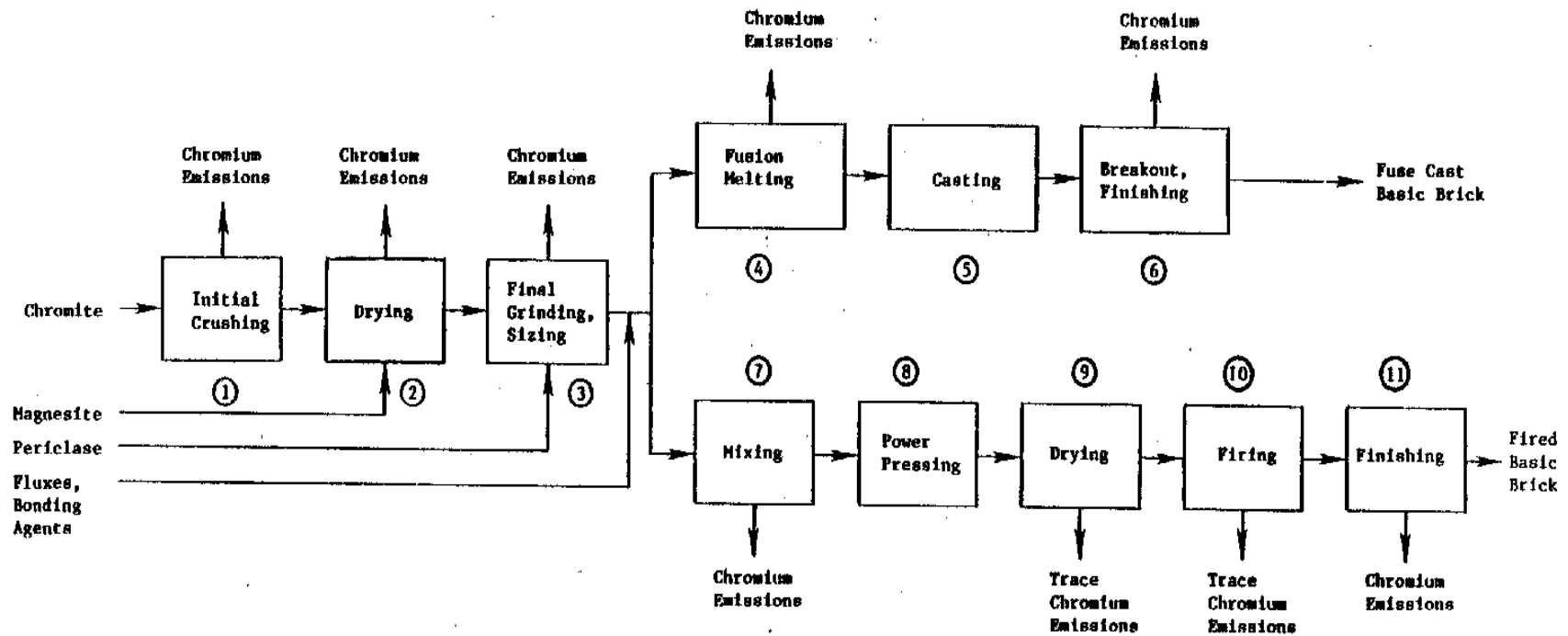

Figure 13. Flow chart for production of chromium-containing basic brick by casting and pressing processes. 16

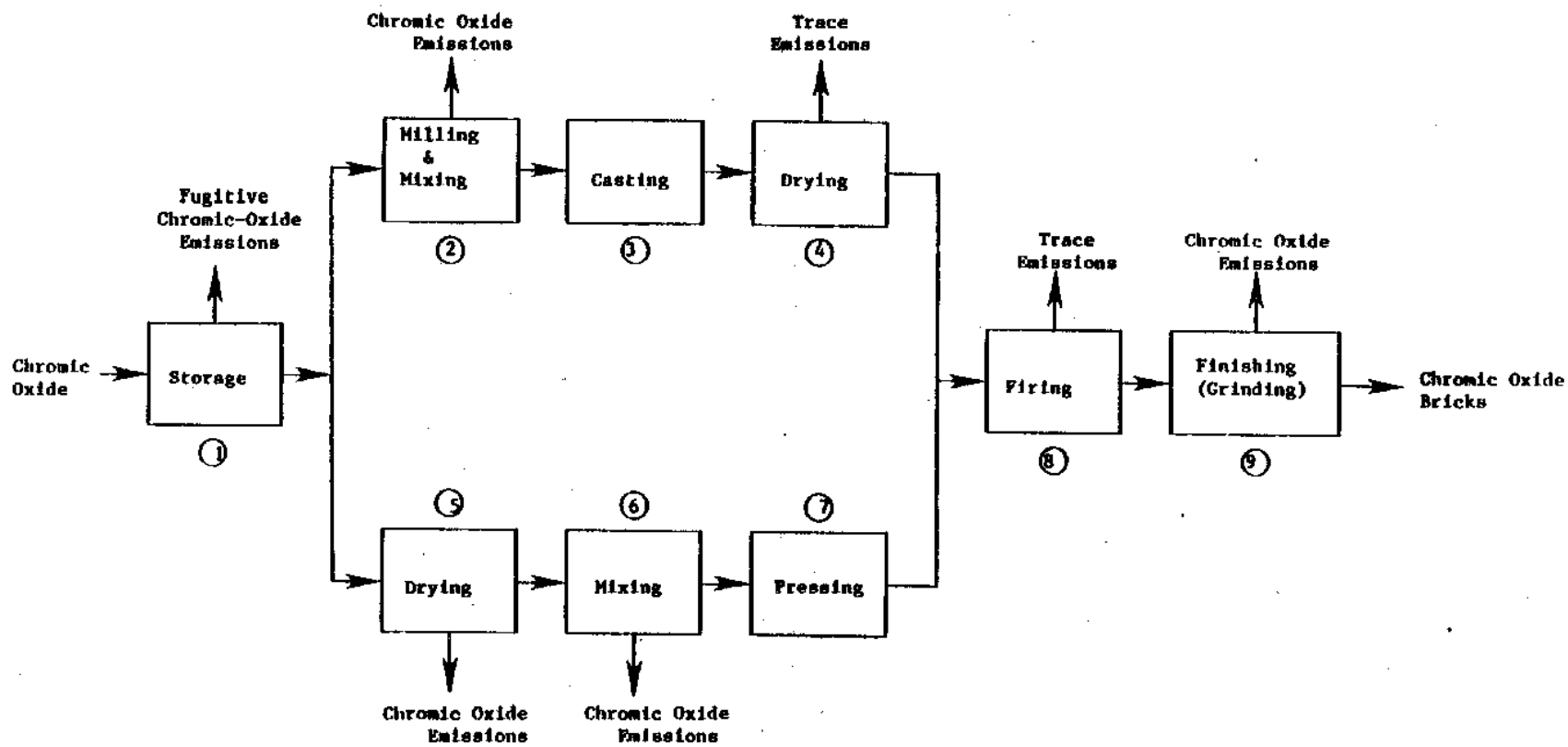

Figure 14. Flow chart for production of chromic oxide bricks by casting and pressing processes. 20

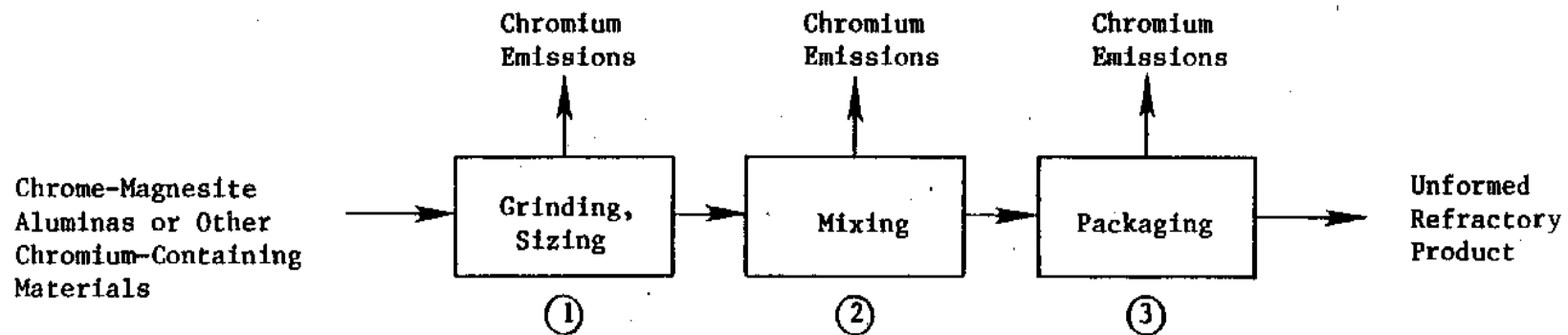

Figure 15. Flow chart of production of unformed refractories.¹⁶

The raw materials processing step can include crushing, grinding, drying, and sizing the raw materials (chromite, magnesite, etc.) to meet the specifications of the particular refractory product. The second processing step is forming, which includes mixing the raw materials and forming them into shapes. The third processing step is firing, in which the refractory is heated in a kiln to form a ceramic bond. This bond gives the product its refractoriness (heat-resistant properties) and corrosion-resistant properties. The final processing step includes post-firing operations such as milling, grinding, sawing, coating, and packaging of the formed or unformed refractory product.

Figure 13 illustrates the fusion casting and pressing processes that can be used to manufacture chromium-containing basic brick. In both processes the raw materials processing steps are the same: Chrome ore undergoes initial crushing, drying in kilns, and final grinding and sizing (Figure 13, pts. 1-3). Other components of the brick, such as magnesite and periclase (a synthetic form of magnesite), are deadburned, ground and sized (Figure 13, pts. 2 and 3). Fluxes and bonding agents are added during mixing, which occurs after final grinding and sizing.^{16,18} A few refractory manufacturing facilities use hexavalent Chromium compounds such as chromic acid and sodium chromate in small amounts as raw materials in addition to trivalent chromite ore.¹⁹ However, the amount of hexavalent chromium used is very small relative to the amount of chromite ore used. Total consumption by the refractory industry of chromic acid, the most widely used hexavalent compound, was 630 Mg (700 tons) per year in 1980-82¹⁹ versus 125,100 to 139,500 Mg (139,000 to 155,000 tons) per year of chromite ore consumed by the industry during the same period.²⁰

The fusion casting and pressing processes differ most prominently in the forming and firing operations. In the casting process the processed raw materials are fusion melted together in an electric arc furnace (Figure 13, pt. 4) and cast into molds (Figure 13, pt. 5). The final step in the casting process involves breaking the shape out of the mold and grinding or sawing to specification

(Figure 13, pt. 6).¹⁶

In the more common pressing and firing process, the products of the raw materials processing steps are combined in mixers (Figure 13, pt. 7). Then they are shaped with a power press or occasionally a combination of heat and pressure (Figure 13, pt. 8). The pressed bricks are then dried in a tunnel dryer (Figure 13, pt. 9) to reduce the moisture content before firing and to develop strength for subsequent handling.^{16,18}

Firing of the refractory (Figure 13, pt. 10) is usually accomplished in a tunnel kiln. A few small use plants periodic kilns instead, which are slower and less efficient. In a tunnel kiln, the formed brick travels along the tunnel through different temperature zones. The zones include a pre-heating zone, a zone of maximum temperatures, and a cooling zone. Maximum temperatures range from 1,100 to 1,870°C (2,000 to 3,400°F) depending on the type of refractory being produced. A ceramic bond can be formed at temperatures of about 1,370°C (2,500°F). Chrome refractory bricks are meant to withstand especially high temperatures and corrosive conditions and are fired at a higher temperature of about 1,760°C (3,200°F). At this temperature a strong direct chemical bond is formed from recrystallization of the chromite, magnesite, and bonding agents. Total residence time in the kiln ranges from 8 hours to over 4 days depending on the type of refractory being produced.^{16,22}

The last step in the pressing and firing process is finishing the bricks (Figure 13, pt. 11). This step is similar to the finishing step in the fusion casting process. It can include grinding or sawing the refractory bricks to meet specifications.^{16,17}

Figure 14 is a process flow chart for the production of chromic oxide basic brick by both the casting and pressing processes. Chromic oxide is the raw material for this type of refractory. Chromic oxide may be ground and sized at the plant (as in Figure 13, pts. 1-3), but it is often bought pre-ground to specification. For this reason, Figure 14 begins with the storage of the pre-ground chromic oxide raw material at the plant (Figure 14, pt. 1).^{16,21}

The casting process generally used to produce chromic oxide brick differs somewhat from the fusion casting process for chrome-magnesite basic brick previously discussed. The chrome oxide is mixed (Figure 14, pt. 2), but not fusion melted, before casting (Figure 14, pt. 3). Therefore, the cast products are dried (Figure 14, pt. 4) and fired along with the pressed products (Figure 14, pt. 8) to form the ceramic or chemical bonds. The finishing step (Figure 14, pt. 9) includes grinding or sawing the bricks to specification.²¹

The pressing process which chromic oxide refractories undergo is very similar to that used for production of other types of basic brick. An additional step to dry the chromic oxide (Figure 14, pt. 5) has been added before the mixing and pressing steps. But the mixing, pressing, firing, and finishing of pressed chromic oxide bricks (Figure 14, pts. 6-9) are carried out as previously discussed in connection with the basic brick-pressing process.²¹

Figure 15 illustrates the production of chromium-containing, unformed refractory products such as mortars, plastic or ramming mixes, castables, and gunning mixes. The process consists solely of preparing the raw materials (i.e., grinding, sizing) in Figure 15 (pt. 1), mixing them with additives (Figure 15, pt. 2), and packaging the unformed products in bags or boxes (Figure 15, pt. 3). Mixing is usually a dry process. The forming and firing steps are completely omitted.^{16,17,21}

Emission Factors--

The sources and amounts of chromium emitted from individual plants vary widely depending on the type of refractory being produced and the type of manufacturing equipment used. Most emissions are in the form of trivalent chromic oxide, since hexavalent chromium compounds make up less than 1 percent of the industry's chromium-containing raw materials.¹⁹ The chromium content of raw materials required for different refractory products varies, causing chromium concentrations in raw material-derived particulate emissions to vary. At some plants chrome ore is crushed and ground on-site,

causing chromium emissions, while other plants buy pre-ground chromic oxide. Chromium emission rates also depend on whether a casting or pressing process is used. This section gives an overview of potential sources and rates of chromium emissions occurring in the generalized manufacture of chrome refractories. In order to estimate emissions from a particular plant, its specific manufacturing process would need to be studied.

The discussion of chromium emission sources in the refractory processes refers to Figure 13, Figure 14, and Figure 15. These show chromium emissions from the manufacture of chrome-containing basic bricks, chromic oxide bricks, and unformed refractory products, respectively. The raw materials processing operations appear to be the most significant potential source of chromium emissions from refractory plants. The chrome ore grinding mills (Figure 13, pt. 1) and drying kilns (Figure 13, pt. 2) emit particles of chromite. The final grinding and sizing of raw materials, shown in the formed and unformed refractory flow-charts, also emit chromium-containing particulates. Emissions from these sources are commonly controlled with fabric filters.^{16,21}

Mixers where raw materials are combined may also be sources of emissions. These occur at the start of the formed refractory pressing process loops (Figure 13, pt. 7 and Figure 14, pt. 6) and in the manufacture of unformed refractories (Figure 15, pt. 2). If the mixing is a damp process, emissions are slight. Dry mixing, however, emits a substantial quantity of particulates. Wet scrubbers or cyclone/fabric filter combinations are used to control this source.^{16,21}

Other sources of emissions from the pressing process include dryers and kilns (Figure 13, pt. 9 and pt. 2; Figure 14, pt. 5 and pt. 8). Brick dryers and kilns are viewed as minor sources of chromium emissions. These sources are usually uncontrolled.^{16,21,23,24}

In the manufacture of chrome-containing basic brick by the fusion casting process, chromium emissions originate from arc furnaces where chrome ore and other raw materials are fusion melted (Figure 13, pt. 4). The fluxing action in these arc furnaces entrains chromium-containing fugitive particulates, which are usually collected and controlled by means of a fabric filter.¹⁶

The finishing step is a potential source of chromium emissions during the manufacture of all formed and unformed chrome refractory products. This step, shown in Figure 13, Figure 14, and Figure 15, can include grinding, sawing, and packaging final refractory products. As the chromium-containing refractory products are finished and handled, chromium-containing dust can be generated. Such emissions, if substantial, are usually ducted to fabric filters.¹⁶

Table 11 presents controlled and uncontrolled emission factors for plants producing chrome-containing bricks by the pressing and fusion casting processes. These figures are taken from a 1973 study that reports total uncontrolled pressing process emissions from crushing, sizing and drying of chrome ore raw materials to be 75 kg/Mg (150 lb/ton). This study also reports uncontrolled pressing process emissions from brick firing kilns to be about 0.1 kg/Mg (0.2 lb/ton).²³ A control efficiency of 64 percent from the 1973 study was used to calculate the controlled chromium emission factors shown on Table 11.²³

For the fusion casting process, the 1973 EPA report estimated uncontrolled chromium emissions to be 112 kg/Mg (225 lb/ton).²³ This factor is also included in Table 11. Since the initial processing of raw materials (crushing, sizing) is similar for the casting and pressing processes, it would appear that about 75 Mg/kg (150 lb/ton) would come from raw materials processing. The additional 37 Mg/kg (75 lb/ton) of chromium emitted in the casting process would presumably come from arc furnaces and breakout and finishing of the cast refractory products. The 1973 report assumed 77 percent efficiency in calculating controlled emission rates from the casting process.²³

TABLE 11. CHROMIUM EMISSION FACTORS FOR THE REFRACTORY INDUSTRY ²³

Type of Process	Chromium Emission Factors, kg/Mg (lb/ton) of Refractory Produced ^a	
	Uncontrolled	Controlled
Total Pressing Process	75 (150) ^b	27 (54) ^c
- Ore Crushing, Sizing, Drying	75 (150)	27 (54) ^c
- Brick Firing Kilns	0.1 (0.2) ^d	e
Total Fusion Casting Process	112 (225)	26 (52) ^f
- Ore Crushing, Sizing, Drying	75 (150)	17 (34) ^f
- Fusion Melting, Casting, Breakout, and Finishing	37 (75)	9 (18)

^a Emission factors are expressed in terms of total elemental chromium. Chromium emissions should predominantly contain trivalent chromium.

^b Reference 1818 reported that this emission factor grossly overstates uncontrolled emissions.

^c This figure assumes a 64 percent control efficiency.

^d A 1980 study indicated that uncontrolled emissions from kilns are less than 0.5 kg/Mg (1.0 lb/ton).

^e This source is not controlled.

^f This figure assumes a 77 percent control efficiency.

Recent data indicates that 90 to 99.9 percent control of chromium emissions can be effected in the refractory industry. Controlled chromium emission factors for Table 12 were developed using data on two plants available through state government agencies.^{21,24} Total particulate emission rates from each source listed on Table 12 were available from the agencies. Throughputs of chromium-containing raw materials were also given. To calculate chromium emissions on the basis of per ton of raw materials throughput, three assumptions were made. The first is that refractory grade chrome ore contains 34 percent chromic oxide.²⁵ The second is that the weight of elemental chrome is 68.4 percent of the total weight of chromic oxide (Cr_2O_3). The third is that concentration of chromium in particulates emitted is the same as the concentration of chromium in the raw materials. Table 12 gives the resulting controlled chromium emission factors for different steps in the manufacture of chrome-magnesite and chromic oxide bricks.

Source Locations--

Based on the most recent data available, there are, in 1984, 43 plants owned by 26 companies in the United States producing chromium-containing refractories. The locations of these plants are given in Table 13.^{18,26}

Chromium Chemicals Manufacture

Process Description--

Approximately 40 different chromium chemicals are manufactured in the United States, most of which are low volume chemicals. The largest volume and most commercially significant chromium chemicals are sodium chromate and sodium dichromate. These chromium chemicals are significant because all other domestically manufactured chromium compounds use sodium chromate or dichromate as their primary feedstock material. The more important secondary chemicals include chromic acid, potassium chromate and dichromate, ammonium dichromate, basic chromic sulfate, and chrome pigments (chrome oxide green, chrome yellow, chrome orange, molybdate chrome orange, and chrome green).^{27,28}

TABLE 12. CONTROLLED CHROMIUM EMISSION FACTORS FOR THE REFRACTORY
INDUSTRY ^{21,24}

Emission Source	Chromium Emission Factor kg/Mg (lb/ton) of Raw Materials Processed	Control Device	Control Efficiency %
Chrome-Magnesite Brick Production			
<u>Chrome Ore Preparation</u>			
Ore storage, grinding, and sizing	.01-.05 (.02-.10) ^b	fabric filter	99.9
Dryer	.0018-.002(.0035-.0041) ^b	fabric filter	99.9
Storage in raw materials silo	.0022-.0032(.0045-.0065) ^c	fabric filter	99.9
<u>Pressing and Firing</u>			
Mixer	.0005-.0022(.0011-.0043) ^c	fabric filter	99.9
Brick dryer	.00037 (.00074) ^c	scrubber	90.0
Brick kiln	.00044 (.00099) ^c	scrubber	90.0
Chromic Oxide Brick Production			
<u>Casting Process</u>			
Milling (ball mill)	.48 (.96) ^d	wet scrubber	97.0
Spray dryer	.48 (.96) ^d	fabric filter	97.0
<u>Pressing Process</u>			
Mixer	.48 (.96) ^d	wet scrubber	97.0

^a Emissions reported as total elemental chromium. Chromium emissions should contain predominantly trivalent chromium.

^b Raw materials processed in this step include only-chrome ore.

^c Raw materials processed in this step are a mixture of chrome ore and magnesite.

^d Raw materials processed in this step include only chromic oxide.

TABLE 13. LOCATIONS OF PLANTS PRODUCING CHROMIUM REFRACTORY MATERIALS ^{18,26}

State, City	Company
Alabama	
Anniston	Donoho Clay Company
Pell City	Riverside Refractories, Inc.
California	
Moss Landing	Kaiser Refractories
Colorado	
Pueblo	A. P. Greene Refractories Co.
Georgia	
Augusta	Babcock and Wilcox
Illinois	
Aurora	C-E Refractories
Addison	Magneco/Metrel, Inc.
Chicago	Chicago/Wellsville Fire Brick Co.
	Salazar and Sons, Inc.
Chicago Heights	C-E Refractories
Indiana	
Crown Point	BMI, Inc.
Hammond	Harbison-Walker Refractories
New Carlisle	The Carborundum Company
Kentucky	
South Shore	Didier Taylor Refractories Corp.
Louisiana	
New Iberia	The Carborundum Company
Maryland	
Baltimore	Harbison-Walker Ref ractories General Refractories
Michigan	
Manistee	Martin Marietta Chemicals
South Rockwood	BMI, Inc.
Mississippi	
Pascagoula	Corhart Ref ractories Co.
Missouri	
Mexico	A. P. Greene Refractories Co. Kaiser Refractories
Wellsville	Chicago/Wellsville Fire Brick Co.
Webster Grove	Missouri Refractories
New Jersey	
Old Bridge	The Quigley Company

TABLE 13. (CONTINUED) LOCATIONS OF PLANTS PRODUCING
CHROMIUM REFRACTORY MATERIALS ^{18,26}

State, City	Company
New York	
Falconer	The Carborundum Company
Ohio	
Cincinnati	Coastal Refractories, Inc Didier Taylor Refractories Corp.
Columbiana	Kaiser Ref ractories
Irondale	Maryland Refractories
Maple Grove	Basic Refractories
Negley	Magneco/Metrel, Inc.
South Webster	BMI, Inc.
Pennsylvania	
Alexandria	Maryland Refractories
Norristown	Resco Products, Inc.
Plymouth Meeting	Kaiser Refractories
Snowshoe	J. H. France Refractories Co.
Somerset	Bognar and Co., Inc.
Tarentum	A. P. Greene Refractories Co.
Womelsdorf	North American Refractories Co.
Zelienople	Lava Crucible Refractories Co.
Utah	
Lehi	General Refractories Co.
West Virginia	
Buckhannon	Cohart Refractories Co.

Note: This listing is subject to change as market conditions change, facility ownership changes, plants are closed down, etc. The reader should verify the existence of particular facilities by consulting current listings and/or the plants themselves. The level of chromium emissions from any given facility is a function of variables such as capacity, throughput, and control measures. It should be determined through direct contacts with plant personnel.

The production of the primary compounds, sodium chromate and dichromate, has the greatest potential for atmospheric emissions of all the chromium chemical manufacturing processes. The emissions potential is great because of the large volume level of production, the large quantity of chromite ore processed, and the dry chemistry operations in the chromate and dichromate processes. Chromium emissions from the production of many other chromium chemicals are negligible or nonexistent because the processes involve all wet chemistry and/or the processes are of relatively low temperature to prevent any chromium volatilization. Little or no information is available to characterize the production and emissions of secondary chromium chemical compounds.

The processes used to manufacture sodium chromate and sodium dichromate are shown in Figure 16 and Figure 17, respectively. To initiate the sodium chromate process chrome ore is crushed (if it was not bought already sized to specification), dried, and ground to a powder in a ball mill (Figure 16, pt. 1). The ground chrome ore is then mixed (Figure 16, pt. 2) with soda ash, lime, and usually leached calcine residue from a previous roasting operation. The mixture is then roasted in a rotary kiln at temperatures of 1,100 to 1,150°C (2,010-2,100°F) for about 4 hours (Figure 16, pt. 3). Oxidation occurs and sodium chromate is produced with the basic reaction being:

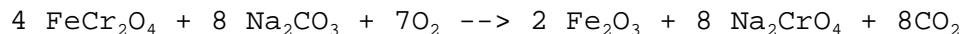

At the American Chrome and Chemical plant, a gas-fired furnace equipped with a revolving annular hearth is used instead of a rotary kiln to accomplish the roasting reaction.²⁷

The kiln roast is then discharged through a cooler and leached (Figure 16, pt. 4) The leached calcine is recycled to the raw materials mixing station (Figure 16, pt. 2) for the purpose of diluting the kiln feed. If sodium aluminate is present in the

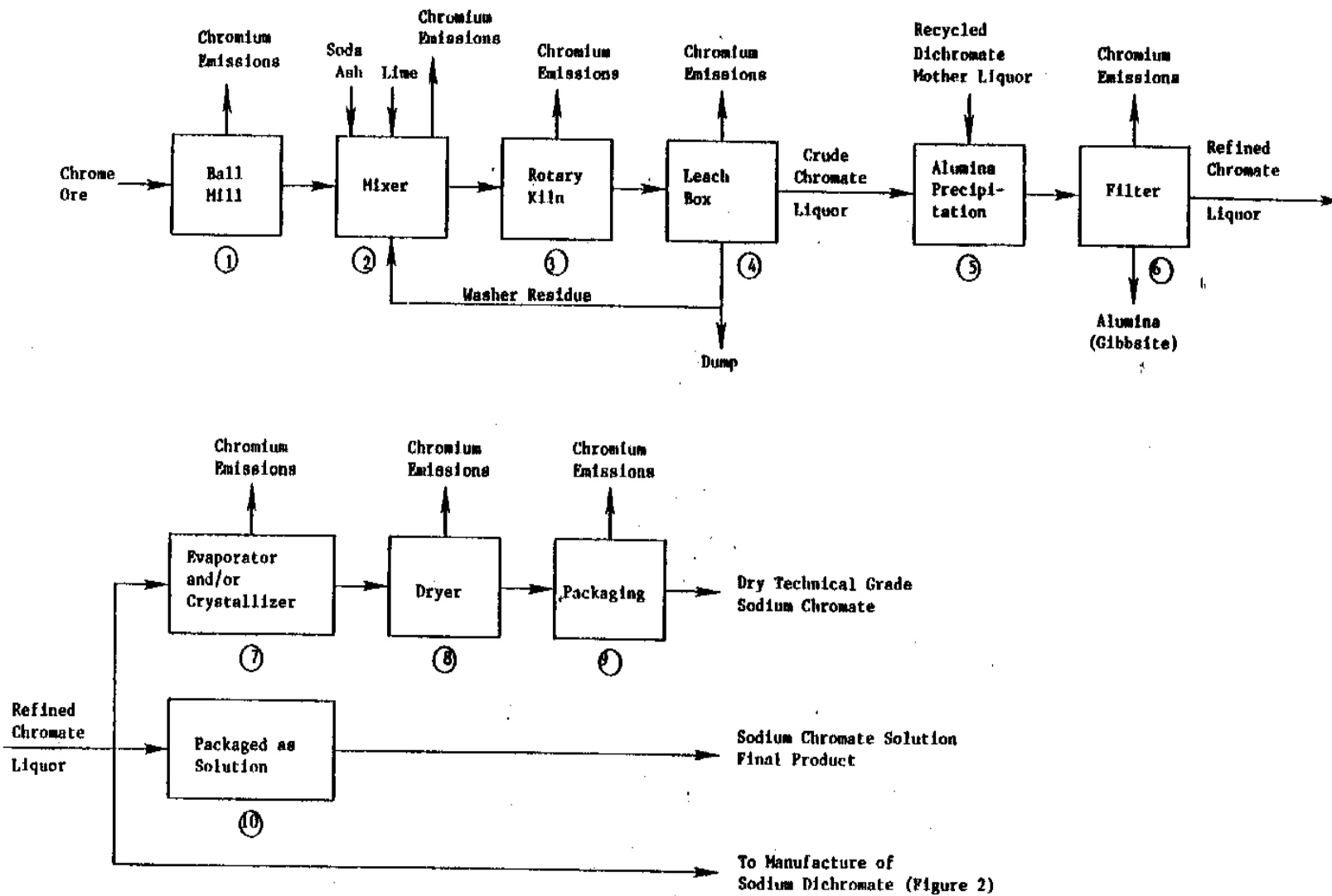

Figure 16. Flow chart for the production of sodium chromate. 27-29

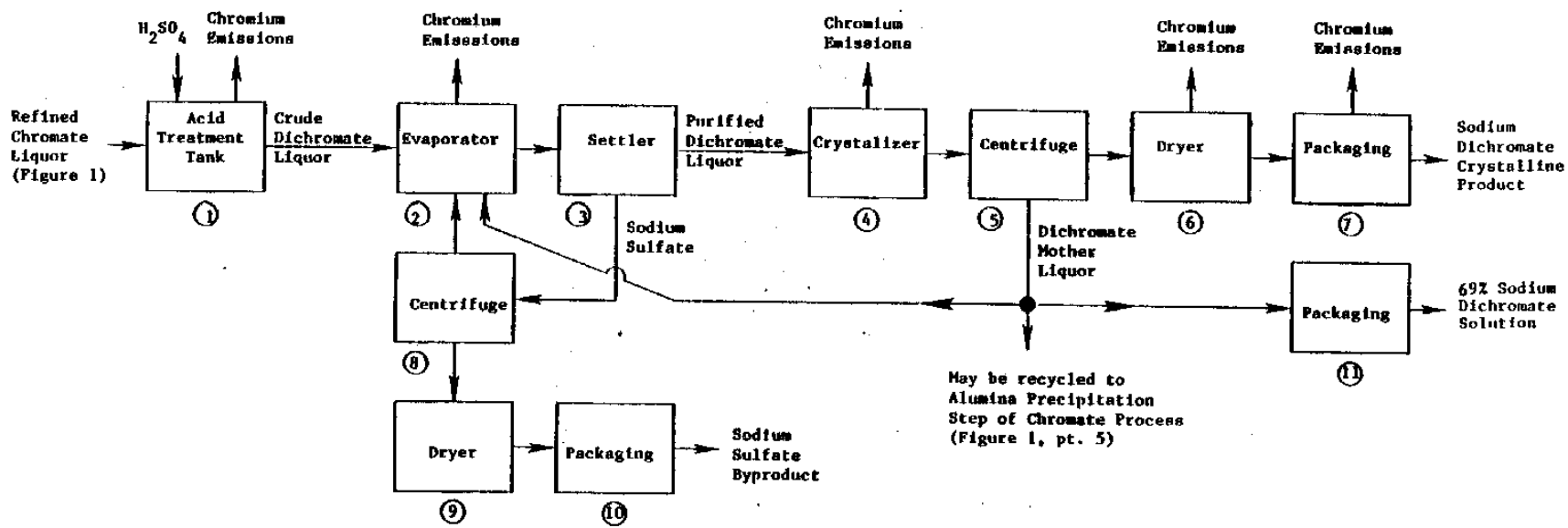

Figure 17. Flow chart for the production of sodium dichromate from chromate liquor. 27-29

chromate liquor, alumina must be precipitated before any further chromium processing. To accomplish this, sodium dichromate liquor from the dichromate manufacturing process is typically added to hydrolizing tanks (Figure 16, pt. 5) and the pH of the solution maintained at 9. Alumina in the form of gibbsite ($\text{Al}_2\text{O}_3 \cdot \text{H}_2\text{O}$) then precipitates and is filtered off (Figure 16, pt. 6), leaving a refined chromate liquor. A variation on this process, which involves raising the pH to 10 and then lowering it to 6.5, is claimed to give very readily filterable alumina.²⁷

The refined chromate liquor can then be sold as a solution, or it can be evaporated to dryness or crystallized (Figure 16, pt. 7 and pt. 8) and sold as technical grade sodium chromate or sodium chromate tetrahydride.²⁷

Most of the refined chromate liquor generated is used to produce sodium dichromate. During this process, sodium chromate is converted to dichromate ($\text{Na}_2\text{Cr}_2\text{O}_7$) by treatment with sulfuric acid (Figure 17, pt. 1). The sodium dichromate liquor is evaporated and a sodium sulfate byproduct is precipitated (Figure 17, pt. 2 and pt. 3). The now purified and concentrated dichromate liquor is crystallized (Figure 17, pt. 4), put through a crystal centrifuge (Figure 17, pt. 5), and dried (Figure 17, pt. 6) and packaged (Figure 17, pt. 7) as the final sodium dichromate product.^{27,29}

The sodium sulfate, which was precipitated at pt. 3, is centrifuged and dried (Figure 17, pt. 8 and pt. 9). The filtrate is recycled to the evaporator (from Figure 17, pt. 8 to pt. 2), and the dried sodium sulfate is packaged (Figure 17, pt. 10) and sold. Sodium dichromate mother liquor is generated when the sodium dichromate is crystallized and centrifuged (Figure 17, pt. 4 and pt. 5). It can be packaged (Figure 17, pt. 11) and sold as 69 percent sodium dichromate solution or recycled to the dichromate evaporation (Figure 17, pt. 2) or alumina precipitation (Figure 16, pt. 5) operations.^{27,29}

To illustrate the significance and role of sodium chromate and sodium dichromate in the production of secondary chromium chemicals, brief process descriptions are presented of chromic acid and potassium and ammonium dichromates production. The production of numerous other secondary chromium chemicals is not described, nor are emissions data available therein. For more details on these production processes, the reader should consult references 27 and 29.^{27,29}

Chromic acid (CrO_3), also known as chromium trioxide or chromic anhydride, can be produced by more than one method. The traditional chromic acid production process involves mixing sodium dichromate dihydrate with sulfuric acid in a reactor which is heated externally and stirred with a sweep agitator. The chemical reaction taking place is shown below.

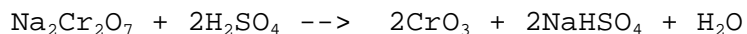

Water is driven off and the hydrous sodium bisulfate melts at 160° (320°F). The molten bisulfate provides a heat transfer medium for the melting of chromic acid at 197°C (387°F). The agitator is turned off, and the mixture separates into a heavy layer of molten chromic acid and a light layer of sodium bisulfate. The chromic acid layer is tapped from the reactor and flaked on water cooled rolls to produce the commercial product.²⁷

A second method for producing chromic acid is illustrated by Figure 18.27,30 A large amount of sulfuric acid is first added to a concentrated solution of sodium dichromate (Figure 18, pt. 1). A crude chromic acid containing sodium bisulfate and some sulfuric acid is precipitated and separated by filtration (Figure 18, pt. 2). The crude chromic acid is then melted (Figure 18, pt. 3) in this small amount of sodium bisulfate, with sodium dichromate added to convert any excess sulfuric acid into chromic acid. The chromic acid is then flaked as in the traditional process (Figure 18, pt. 4), packaged (Figure 18, pt. 5), and sold. Less waste sodium bisulfate is produced by this process than by the traditional chromic acid manufacturing process.^{27,30,31}

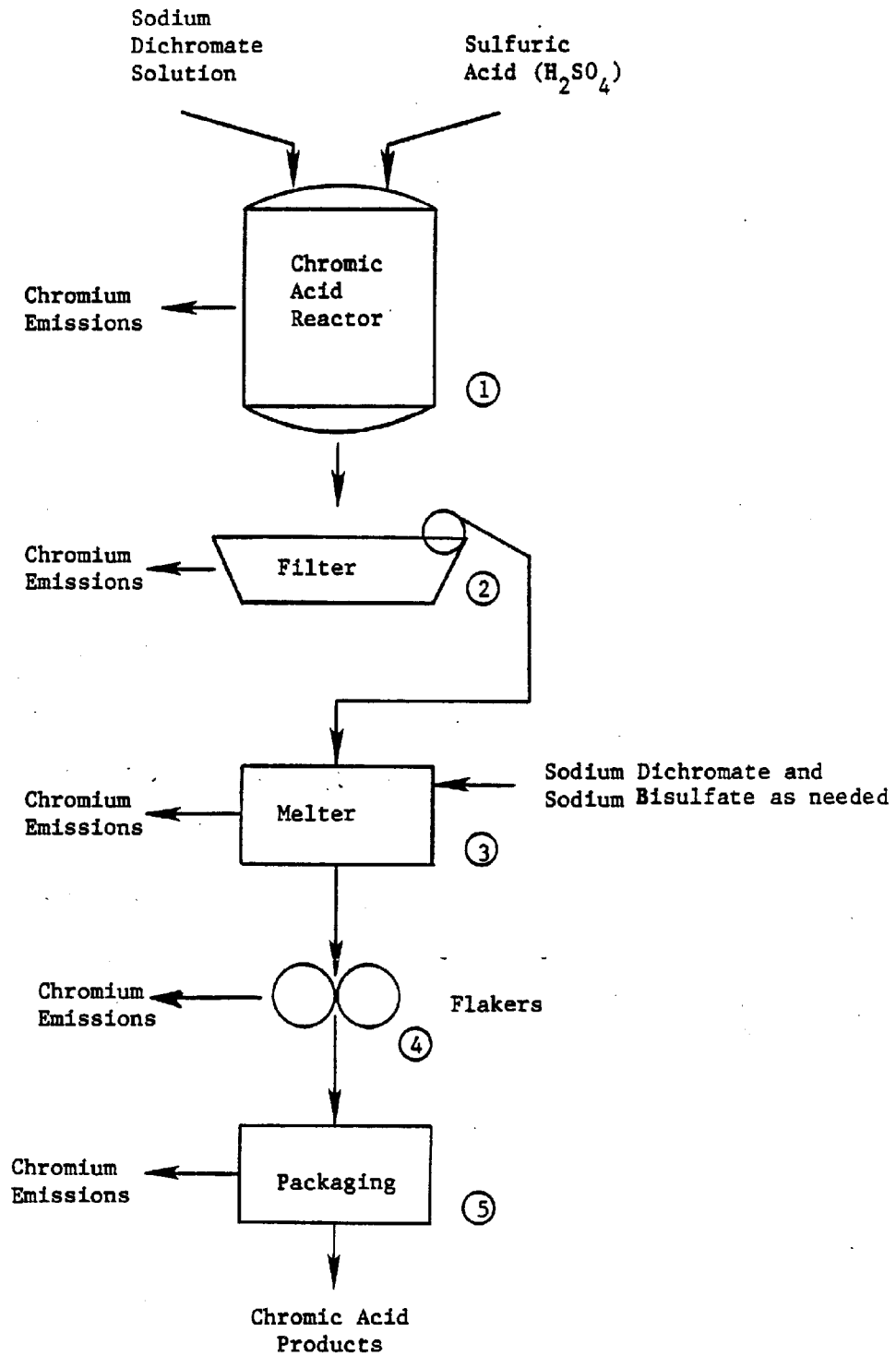

Figure 18. Flow chart for chromic acid production. ^{27,30}

Potassium and ammonium chromates and dichromates are also produced from sodium dichromate. These are generally made by reacting sodium dichromate with an equivalent amount of potassium chloride or ammonium sulfate in a crystallization process. Care must be taken in drying ammonium dichromate because decomposition starts at 185°C (365°F). Potassium chromate is made from the reaction of potassium dichromate and potassium hydroxide.²⁷

Emission Factors--

Possible sources of chromium-containing emissions from the production of sodium chromate are shown in Figure 16. The ball mill and mixer (Figure 16, pt. 1 and pt. 2) emit chrome ore particulates. Fabric filters are typically used to control these sources with efficiencies of over 99 percent.^{27,32,33} Chromium emissions from kilns (Figure 16, pt. 3) are controlled with ESPs or cyclones and scrubbers.^{27,32,34,35} Electrostatic precipitators can be over 99 percent efficient in controlling chromium emissions from this source;^{27,32,35} cyclones and scrubbers are somewhat less effective. Leaching tanks, (Figure 16, pt. 6) also emit chromium. These are usually hooded and emissions are funneled into stacks equipped with wet scrubbers. From 90 to over 98 percent control has been achieved depending on the type of scrubber and the throughput.^{27,36} The filter (Figure 16, pt. 6) is the final chromium emission source in the production of refined sodium chromate liquor. If the chromate liquor is then converted to dry sodium chromate products, the evaporators and dryers (Figure 16, pt. 7 and pt. 8) will be sources of particulates containing sodium chromate. These sources are controlled with ESPs or cyclones and wet scrubbers. Chromium-containing dust arising from handling and packaging of the final product (Figure 16, pt. 10) is usually channeled into fabric filters.^{27,34}

Sources of chromium-containing particulate emissions from the sodium dichromate manufacturing process (Figure 17) include the acid treatment tank, evaporator, crystallizer, and dryer. These sources are controlled with ESPs or cyclones and wet scrubbers. Emissions

from packaging are controlled by fabric filters. Efficiencies of these devices are similar to those reported in connection with the chromate manufacturing process.^{27,36,37}

The largest sources of chromium emissions from chromic acid production are the reactor, the filter, and the packaging process. Melters and flakers are minor sources. Scrubbers are commonly used to reduce chromium-containing particulates at all of these points, although fabric filters may also be used at the packaging step. Efficiencies of over 95 percent are reported from testing at a plant which uses wet scrubbers.^{27,30,35}

Table 14 gives emission factors derived from a 1973 EPA report for the combined production of sodium chromate and dichromate.²³ All chromate is assumed to be converted to dichromate. Actual emissions testing data were used to determine the uncontrolled factor given for kiln emissions. However, the uncontrolled factor which the 1973 report lists for total process emissions is an estimate based on the assumption that other process emission sources, mainly dryers, emit roughly the same amount as the kiln. The figures given for controlled emissions in Table 14 were based on the 1973 report's assumption of 90 percent control efficiency.²³ As the preceding discussion on emission sources and controls states, efficiencies of well over 90 percent are achieved with modern control devices.

TABLE 14. CHROMIUM EMISSION FACTORS FOR SODIUM DICHROMATE MANUFACTURING PLANTS²³

Source of Emissions	Chromium Emission Factors kg/Mg (lb/ton) of Dichromate Produced ^a	
	Uncontrolled	Controlled
Total Process	15 (30)	1.5 (3.0) ^b
Kiln Only	7.5 (15)	0.7 (1.5) ^b

^a All emission factors expressed in terms of total elemental chromium. Emissions should contain chromium in predominantly the hexavalent oxidation state.

^b Factor assumes a control efficiency of 90 percent.

Table 15 lists chromium emission factors for chromic acid production derived from test data on one plant.³⁰ The total raw materials throughput and particulate emission rates were given for each step of the plant's chromic acid process. To derive the figures in Table 15, it was assumed that particulates emitted were mainly chromic acid and that chromium constitutes 52 percent of chromic acid by weight.

No emission factors are available for the production of other secondary chromium chemicals.

TABLE 15. CHROMIUM EMISSION FACTORS FOR CHROMIC ACID PRODUCTION³⁰

Emission Source	Chromium Emission Factors kg/Mg (lb/ton) of Raw Materials Processed ^a		Measured Control Efficiency
	Uncontrolled	Controlled	
Chromic Acid Reactor, Melter, and Flaker	0.2 (0.4)	.01 (.02) ^b	95%
Chromic Acid Filter	1.4 (2.8)	.01 (.03) ^b	99%
Packaging	0.7 (1.4)	.04 (.07) ^b	95%

^a Factors reported as total elemental chromium. Emissions should contain chromium in predominantly the hexavalent oxidation state.

^b Emission source controlled by scrubbers.

Source Locations--

There were three plants in the United States in 1983 producing sodium chromates and dichromates. Their locations are given in Table 16.³⁸ The locations of plants producing secondary chromium chemicals are shown in Table 17.³⁹

TABLE 16. LOCATIONS OF SODIUM CHROMATE AND SODIUM DICHROMATE
MANUFACTURING PLANTS ³⁸

Owner	Location	Production of Sodium Chromate as End Product
Allied Corp.	Baltimore, MD	Yes
American Chrome & Chemicals, Inc.	Corpus Christi, TX	Yes
Diamond Shamrock	Castle Hayne, NC	No

Note: This listing is subject to change as market conditions change, facility ownership changes, plants are closed down, etc. The reader should verify the existence of particular facilities by consulting current listings and/or the plants themselves. The level of chromium emissions from any given facility is a function of variables such as capacity, throughput, and control measures. It should be determined through direct contacts with plant personnel.

Chromium Plating

Process Description--

Chromium is plated onto various substrates in order to provide a decorative and corrosion resistant surface. Steel, brass, aluminum, plastics, and zinc die castings may serve as substrates. The two major types of chromium plating are decorative and hard. Decorative plate consists of a thin (0.25 μm thick) layer of chromium which is applied over a layer of nickel to provide a bright, tarnish-resistant surface. Decorative chrome plate is popular for consumer items such as auto trim. Hard plating produces a thicker chromium layer (10 to over 300 μm thick) which has excellent hardness and wear-resistance and a low coefficient of friction.^{40,41} Applications include drills, reamers, burnishing bars, drawing plugs or mandrels, drawing dies, plastic molds, gages, pump shafts, rolls and drums, hydraulic rams, and printing plates.⁴² The electroplating process used to produce the two types of chromium plates are similar.

TABLE 17. LOCATIONS OF COMPANIES PRODUCING SECONDARY CHROMIUM CHEMICALS³⁹

Chemical Compound and Corporate Producer	Location
Ammonium dichromat Allied Corporation Richardson-Vicks, Inc.	Baltimore, MD Phillipsburg, NJ
Barium chromate Barium and Chemicals, Inc. National Industrial Chemical Co.	Steubenville, OR Chicago, IL
Chrome lignosulfonate Dixie Chemical Co.	Bayport, TX
Chromic acid Allied Corporation Diamond Shamrock Corp.	Baltimore, MD Castle Hayne, NC
Chromium acetate American Cyanamid Co. Blue Grass Chemical Specialties Co. McGean Chemical Co., Inc. The Shepherd Chemical Co.	Charlotte, NC New Albany, IN Woodbridge, NJ Cleveland, OH Cincinnati, OH
Chromium acetylacetone Gulf Oil Corp. McKenzie Chemical Works, Inc. The Shepherd Chemical Co.	Gloucester City, NJ Bush, LA Cincinnati, OH
Chromium bromide mono- Thiokol Corp.	Danvers, MA
Chromium carbide Union Carbide Corp.	Niagra Falls, NY
Chromium carbonyl Pressure Chemical Co. Strem Chemicals, Inc.	Pittsburgh, PA Newburyport, MA
Chromium chloride, basic Diamond Shamrock Corp.	Ashtabula, OH
Chromium chloride, (chromic) Blue Grass Chemical Specialties, Inc. McGean Chemical Co., Inc.	New Albany, IN Cleveland, OH

TABLE 17.(CONTINUED)LOCATIONS OF COMPANIES PRODUCING
SECONDARY CHROMIUM CHEMICALS³⁹

Chromium diboride Thiokol Corp.	Danvers, MA
Chromium diflouride Pennwalt Corp.	Tulsa, OK
Chromium dioxide E.I. DuPont de Nemours & Co., Inc.	Newport, DE
Chromium 2-ethylhexanoate Mooney Chemicals, Inc. The Shepherd Chemical Co.	Franklin, PA Cincinnati, OH
Chromium flouride Gulf Oil Corp.	Cleveland, OH
Chromium hydroxide Pfizer Inc.	Lehigh Gap, PA
Chromium hydroxy diacetate McGean Chemical Co., Inc.	Cleveland, OH
Chromium hydroxy dichloride McGean Chemical Co., Inc.	Cleveland, OH
Chromium naphthenate Mooney Chemicals, Inc. Troy Chemical Corp.	Franklin, PA Newark, NJ
Chromium nitrate Allied Corporation The Shepherd Chem. Co.	Claymont, DE Cincinnati, OH
Chromium oleate The Shepherd Chem. Co. Troy Chemical Corp.	Cincinnati, OH Newark, NJ

TABLE 17.(CONTINUED)LOCATIONS OF COMPANIES PRODUCING
SECONDARY CHROMIUM CHEMICALS³⁹

Chromium oxide (chrome greens)	
Ciba-Geigy Corp.	Glens Falls, NY
Minnesota Mining and Manufacturing Co.	Copley, OH
National Industrial Chemical Co.	Chicago, IL
Pfizer Inc.	Lehigh Gap, PA
Rockwood Industries, Inc.	Los Angeles, CA Beltsville, MD
Chromium phosphate	
Ciba-Geigy Corp.	Glens Falls, NY
National Industrial Chemical Co.	Chicago, IL
Chromium potassium sulfate	
McGean Chemical Co., Inc.	Cleveland, OH
Chromium sulfate	
Blue Grass Chemical Specialties, Inc.	New Albany, IN
Hydrice Chemical Co.	Milwaukee, WI
Chromium sulfate, basic	
Ciba-Geigy Corp.	Salem, MA
Chromium triacetate	
Diamond Shamrock Corp.	Ashtabula, OH
Chromium triflouride	
Pennwalt Corp.	Tulsa, OK
Lead chromate (chrome yellow)	
Ciba-Geigy Corp.	Glens Falls, NY
Hydrite Chemical Co.	Milwaukee, WI
National Industrial Chemical Co.	Chicago, IL
Rockwood Industries, Inc.	Los Angeles, CA Beltsville, MD
Molybdate orange	
Ciba-Geigy Corp.	Glens Falls, NY

TABLE 17.(CONTINUED)LOCATIONS OF COMPANIES PRODUCING
SECONDARY CHROMIUM CHEMICALS³⁹

Potassium chromate		
Allied Corporation		Baltimore, MD
Potassium dichromate		
Allied Corporation		Baltimore, MD
Strontium chromate		
Barium and Chemicals, Inc.		Steubenville, OH
National Industrial Chemical Co.		Chicago, IL
Rockwood Industries, Inc.		Beltsville, MD
Zinc chromate		
National Industrial Chemical Co.		Chicago, IL
Rockwood Industries, Inc.		Beltsville, MD
		Los Angeles, CA

Note: This listing is subject to change as market conditions change, facility ownership changes. plants are closed down, etc. The reader should verify the existence of particular facilities by consulting current listings and/or the plants themselves. The level of chromium emissions from any given facility is a function of variables such as capacity, throughput,. and control measures. It should be determined through direct contacts with plant personnel.

Figure 19 provides a generalized flow chart for decorative chromium plating on a steel substrate. Figure 20 shows the hard plating process, for which steel is the usual substrate. Possible variations on the processes shown in Figure 19 and Figure 20 are discussed below. Plating operations generally involve dipping the substrate into tanks containing various solutions. The substrate items may be moved between tanks manually or using automation. The decorative and hard plating processes both involve cleaning and preparing the substrate followed by the electrodeposition of chromium. It should be noted that rinsing is carried out between every cleaning and plating step. When a part being plated is moved from one tank to the next, some of the solution from the first tank will remain on the part and be transferred to the next tank. This process is termed drag-in, and rinsing between plating steps is necessary to reduce contamination of plating solutions by drag-in.

The chromium plating processes start with a pretreatment step (Figure 19, pt. 1 and Figure 20, pt. 1) which can consist of mechanical buffing, polishing, and vapor degreasing or soaking in an organic solvent. Alkaline cleaning (Figure 19, pt. 2 and Figure 20, pt. 2) removes surface soil and is accomplished by soaking and/or electrolytic processes. Gas evolution on the surface of the substrate aids the cleaning agent's action in electrolytic alkaline cleaning. More details on electrolytic processes are given in reference 4141 in connection with chromium electroplating tanks. After cleaning, the substrate is dipped in acid (Figure 19, pt. 3 and Figure 20, pt. 3) to remove tarnish and to neutralize the alkaline film on its surface. At this point, the steel substrate is clean and ready to accept a metal deposit.

In the case of decorative chromium plating, an undercoat of copper is applied to the steel in two plating steps, with an acid rinse between each step (Figure 19, pts. 4-6). Next a nickel plate is applied by electrodeposition (Figure 19, pt. 7 and pt. 8). These undercoats prohibit undesirable reactions between the substrate and the final plate which could embrittle the final product. Nickel also

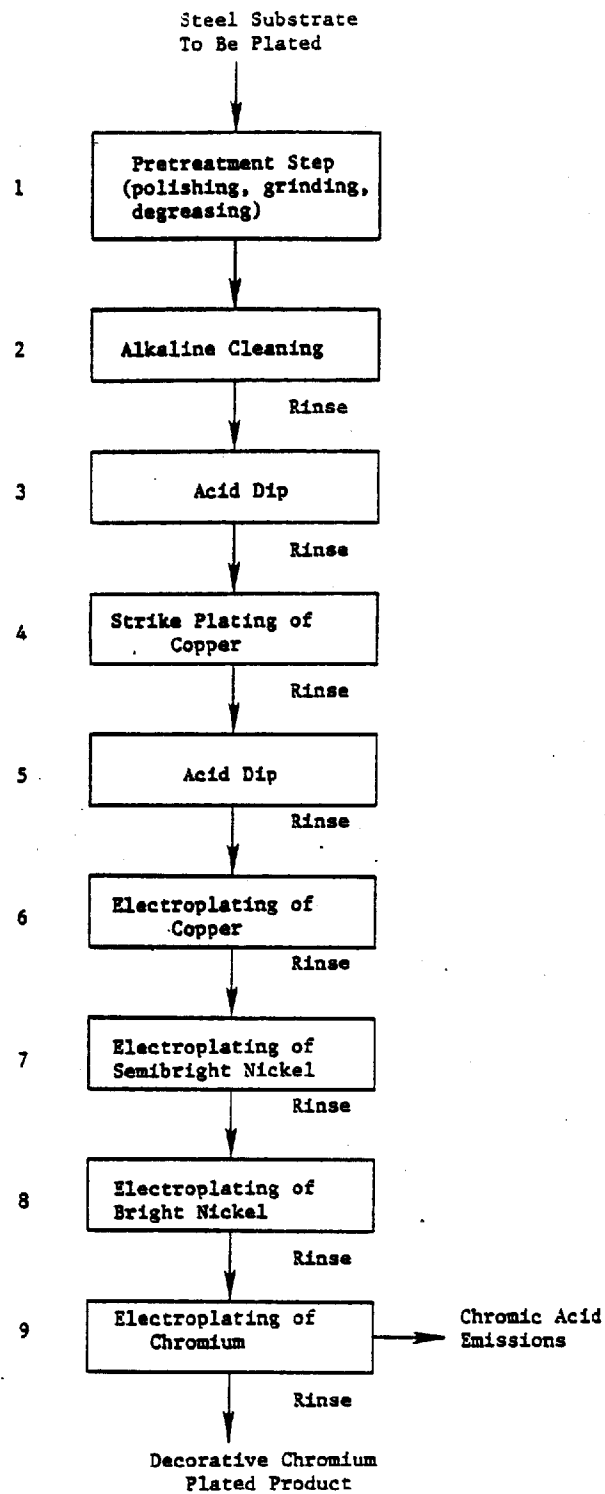

Figure 19. Flow chart for decorative chromium plating on a steel substrate. ⁴²

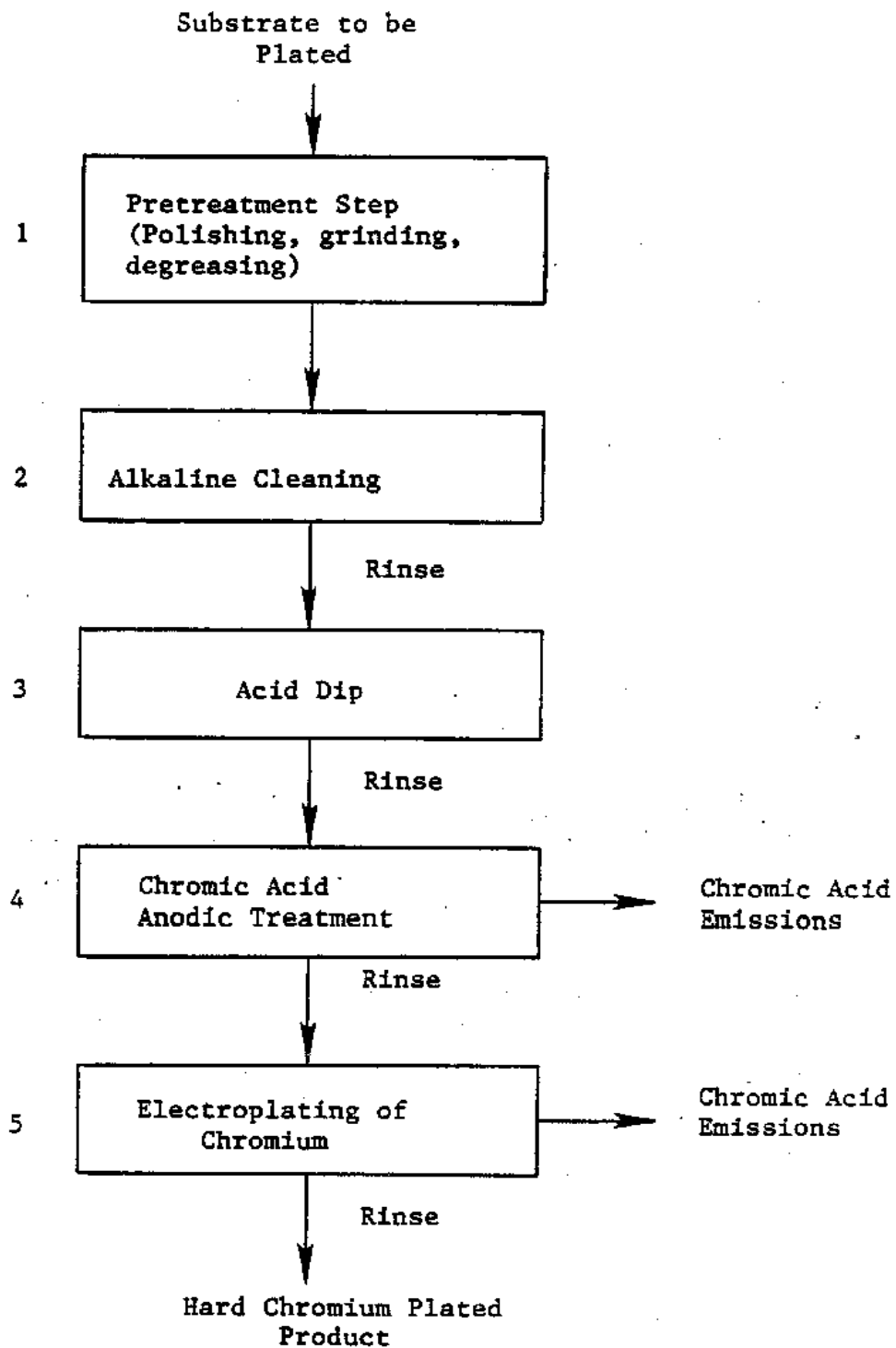

Figure 20. Flow chart for hard chromium plating. ⁴²

provides the basic protection and wear-resistance of the plated part since the decorative chrome layer is very thin. The final step in the decorative plating process is the electrodeposition of a thin layer of chrome (Figure 19, pt. 9).

In the hard chromium plating process, the cleaned substrate undergoes an anodizing treatment (Figure 19, pt. 4). This puts a protective oxide film on the metal by an electrolytic process in which the substrate serves as the anode. Then the hard chromium layer is electrodeposited (Figure 19, pt. 5) without any undercoating of copper or nickel.^{40,41,42}

A typical chromium electroplating tank is pictured in Figure 21.⁴² The system consists of a cathode and an anode, both immersed in electrolyte. Generally the part to be plated functions as the cathode, and the anode is a bar of lead-antimony or lead-tin alloy. The electrolyte contains ions of hexavalent chromium (from chromic acid) and small amounts of another anion, usually sulfate. The sulfate, or sometimes fluoride, improves the electrical conductivity of the electrolyte bath.⁴²

To accomplish the plating process, low voltage direct current process electricity is charged through the electrolyte bath. Electrolytic decomposition of water in the bath releases hydrogen gas at the cathode and oxygen at the anode. As these gases rise to the surface of the bath, a mist of electrolyte is formed and chromium metal is deposited on the substrate.

Table 18 shows the composition of conventional chromium plating solutions, and the temperature and current densities in a typical tank. Recently developed proprietary processes substitute fluoride or fluorsilicate ions for sulfate ions in the electrolytic plating solution, resulting in more efficient chromium plating. Another area of present investigations involves using trivalent chromium baths as an alternative to hexavalent chromic acid plating baths. The extent of use of trivalent chromium plating solutions is unknown.

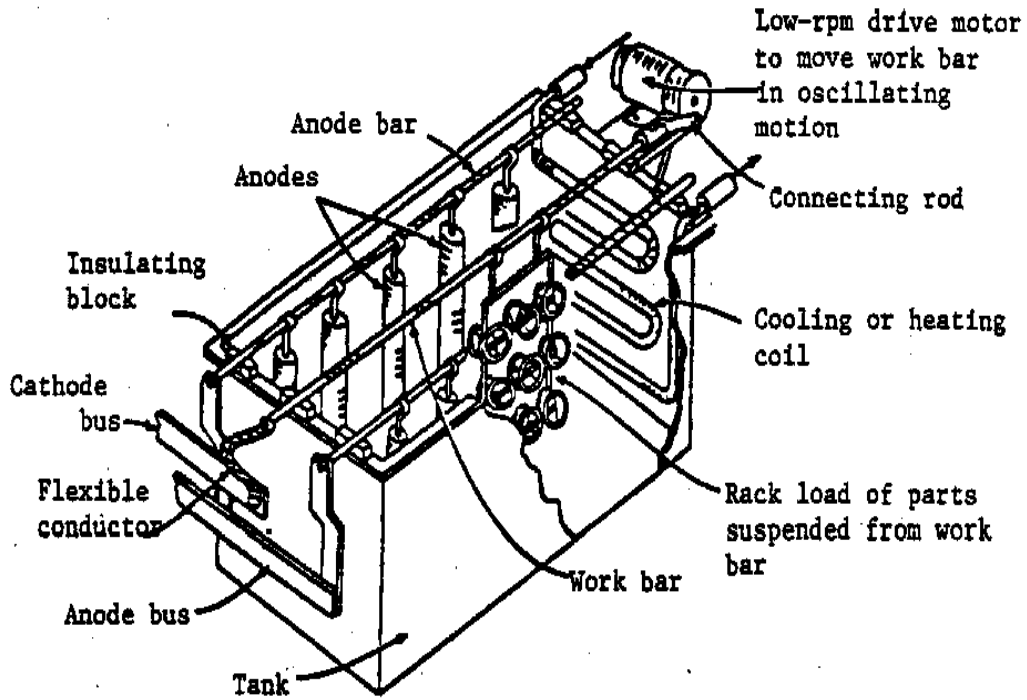

Figure 21. Cutaway view of electroplating tank.⁴²

TABLE 18. TYPICAL CHROMIUM-PLATING CONDITIONS USING CONVENTIONAL BATHS ⁴²

	Decorative Plates	Hard Chromium	
		Dilute	Concentrated
Chromic acid (CrO ₃), g/l	250-400	250	400
Sulfuric acid (H ₂ SO ₄), g/l	2.5-4	2.5	4
Cathode current density, A/m ²	1250-1750	3100	2200
Temperature, °C	38-43	55	50
Deposition rate, μm/hr	8-13	25	13

Current efficiency of chromium deposition is low, about 8 to 12 percent for conventional baths and up to 20 percent for newer flouride ion solutions. This and other factors combine to require long plating times for depositions of the thickness required in hard chromium plating. Table 18 gives typical chromium plate deposition rates.⁴²

The chromium electrodeposition step is the same no matter what substrate material is used. However, the cleaning and preparation of other metal substrates may differ from those discussed for steel (Figure 19 and Figure 20). For example, the copper undercoat may be applied in one plating step rather than the two copper plating steps for steel substrates shown in Figure 19. Similarly, nickel underplate may be applied in one rather than two steps. On aluminum substrate, a zinc plate is usually applied before the copper plate. When plating on plastic, the cleaned surface must be activated, rendered catalytic, and given an electroless deposit of nickel or copper before the electrolytic deposition of copper, nickel, and chromium.⁴⁰ These process variations, however, do not affect the procedures used in or emissions from the final chromium electroplating step.

Emission Factors--

The only potential source of chromium emissions from the decorative chromium plating process is the electroplating step (Figure 19, point 9). Chromium emissions from the hard plating process (Figure 20) are generated in the electroplating step and in the chromic acid anodizing treatment step. In the chromium electroplating steps of the decorative and hard plating processes, mists or aerosols of the electrolyte (primarily chromic acid) are generated. Variables that affect electroplating emission rates include the bath temperature, the concentration of bath constituents, the amount of work being plated, and the plating current. The chromium plating tank in the hard chromium process generates more chromic acid mist than the plating tank in the decorative process because a higher current density is used for metal deposition (see Table 18). The higher current density causes higher rates of gassing thereby generating more chromic acid mist.⁴⁰

Hooding is generally used on chromium electroplating tanks to collect chromium-containing gasses and convey them out of the plating building. Wet scrubbers are often used to control chromic acid emissions from plating operations. The efficiency of wet scrubbers in collecting chromium emissions from electroplating tanks is reported to be 95 percent.^{43,44} A system developed at one plating operation combines a wet scrubber, multiple stages of electrostatic precipitators, and an activated carbon filter. The tested chromium removal efficiency is 99.7 percent.⁴⁴

Chromium emission factors for electroplating operations are limited, particularly for the decorative plating process. Table 19 shows chromium emission factors developed from the testing of one hard chromium plating operation.⁴⁵ Emission factor data for decorative plating are much more limited; however, uncontrolled emissions from one 4,920 liter (1,300 gallon) tank used for decorative chromium plating were reported to be 0.20 kg (0.45 lb) of chromic acid per hour.⁴⁰

Source Locations--

There are several thousand chromium plating operations in the United States. Listings can be found in standard manufacturing directories such as the Thomas Register of American Manufacturers and Thomas Register Catalog File.⁴⁶ To access published directories of manufacturing firms and to identify additional chromium electroplaters, use SIC Code 3471 -- Electroplating, Plating, Polishing, Anodizing and Coloring. Sites of chromium electroplaters may also be obtained from the membership roles of the trade associations known as the American Electroplaters Society, Inc. and the National Metal Finishers Association.

TABLE 19. UNCONTROLLED CHROMIUM EMISSION FACTORS FROM ONE HARD
CHROMIUM PLATING FACILITY ⁴⁵

Source of Emissions	Chromium Emission Factor kg/hr m ² (lb/hr ft ²) of Tank Area ^a	
Hard Plating Tank	0.00041	(0.000084)
Hard Plating Tank	0.00026 - 0.0014	(0.000054 - 0.00029)
Hard Plating Tank	0.00043 - 0.0012	(0.000088 - 0.00025)
Chromic Acid Anodizing Tank	0.0093	(0.0019)

^a Factors are expressed in terms of chromic acid. All chromium is in the hexavalent form.

Steel Production

In 1982, 49 percent of the chromite ore consumed in the United States was used in the metallurgical industry, mainly to produce chromium ferroalloys and metals used in steelmaking. Stainless steel accounted for 71 percent of the chromium ferroalloys consumed; full-alloy steel, 15 percent; high-strength, low-alloy, and electrical steels, 3 percent; and carbon steel, 2 percent.⁴⁷

Steel is produced from the refining of pig iron, scrap, alloying materials such as chromium, and other additives in a furnace. Three types of furnaces are currently used. These are the open hearth furnace, the electric arc furnace (EAF) and the basic oxygen process furnace (BOPFs). Separate sections describing the-steel making process and chromium emissions from each type of furnace follow.

Electric Arc Furnaces and Argon-Oxygen Decarburization Vessels

Process Description--

Because some types of steel alloys produced in EAFs and Argon-Oxygen Decarburization (AOD) vessels contain chromium, these furnaces are a source of chromium emissions: In 1980, EAFs accounted for 27.9 percent of domestic raw steel production (up from 10 percent in 1963). Growth in EAF capacity was large in 1981 and such growth is expected to continue.⁴⁸

Electric arc furnaces are typically utilized in semi-integrated and non-integrated steel mills and in specialty shops. Semi-integrated steel mills use direct reduced iron (DRI) in addition to iron and steel scrap to produce finished steel. Non-integrated steel mills use scrap or cooled pig iron produced at another plant to manufacture steel. They typically produce a limited range of products for a regional market. Electric arc furnaces are particularly suited to non-integrated mini-mills producing less than

544,200 Mg (600,000 tons) per year. Since EAFs can run on scrap, these small mills do not need blast furnaces and coke ovens, keeping capital costs relatively low. A number of mini-mills using EAFs entered the market in the past decade.⁴⁸

Electric arc furnaces are used to produce common grades of steel (carbon steel) as well as stainless and alloy steels (specialty steel).⁴⁸ Stainless steels contain from 12 to 25 percent chromium, which imparts the stainless or corrosion-resistant property to the steel.¹⁴ Electric arc furnaces used to produce stainless steels have higher potential chromium emissions than those used to produce carbon steel because the amount of chromium consumed is greater.

In carbon steel facilities, EAFs are used to melt scrap metal. They are also used as the refining vessel where oxygen blowing is performed to oxidize impurities and perform the final chemical adjustment on the steel. In specialty steel shops, EAFs are used primarily as the metal melter. The molten steel from the EAF is then charged to an AOD vessel or other secondary refining vessel.¹ The use of AOD vessels is not expected to increase significantly in the near future since demand for stainless steel is not increasing.⁴⁸ A recent development in the use of EAFs has been the ultra-high power (UHP) furnace. The new UHP furnaces allow more power input to the charge (and thus a faster melting rate) and increases the production rate (a 100-ton normal power EAF has a heat time of about 3 hours while a 100-ton UHP EAF has a heat time of about 1 to 2 hours). Oxyfuel burners and oxygen lances may also be used to increase the melt rate in UHP furnaces.^{48,49}

A typical EAF used for steelmaking operations is shown in Figure 22. The production of steel in an EAF is a batch process where "heats," or cycles, range from 1 to 5 hours, depending upon the size and quality of the charge, the power input to the furnace, and the desired quality of the steel produced. Each heat consists of three steps: charging and backcharging, meltdown and refining, and tapping. Cold steel scrap and sometimes direct reduced iron (DRI) are charged to begin a cycle, and alloy materials and fluxing agents are added for refining. Direct reduced iron is produced from iron ores that are reduced in the presence of excessive quantities of a reducing agent (natural gas, noncoking bituminous coal, anthracite, lignite, etc.) to produce low carbon iron which is used as melting stock along with scrap iron and steel.⁵⁰ The DRI is used as a scrap supplement and as a diluent for residuals in the scrap. Many of the new electric shops are designed to allow for continuous DRI charging through a slot in the roof or side wall. The use of DRI is currently limited in the United States because of the high cost and the availability of the primary reducing agent, natural gas, and because of the relatively low cost and adequate supply of scrap. Currently there are several demonstration plants in the United States that produce DRI with coal as the reducing agent.⁵¹ The coal-based reduction process may provide a more economical means of producing DRI.

During the charging step, iron and steel scrap are loaded into a drop-bottom (clam-shell type) charge bucket with an electromagnet that is suspended from an overhead crane. The charge bucket is filled to a specified weight. When the roof of the furnace has been opened, charging is normally performed by carefully dropping the charge into the open arc furnace from the charge bucket. Some smaller furnaces are charged with scrap directly from the suspended electromagnet and do not utilize a charge bucket.⁴⁸ All steel plants except one charge cold scrap to the electric furnaces. One melt shop routinely charges blast furnace metal to the EAFs, and the molten metal is 36 to 40 percent of the total charged material.

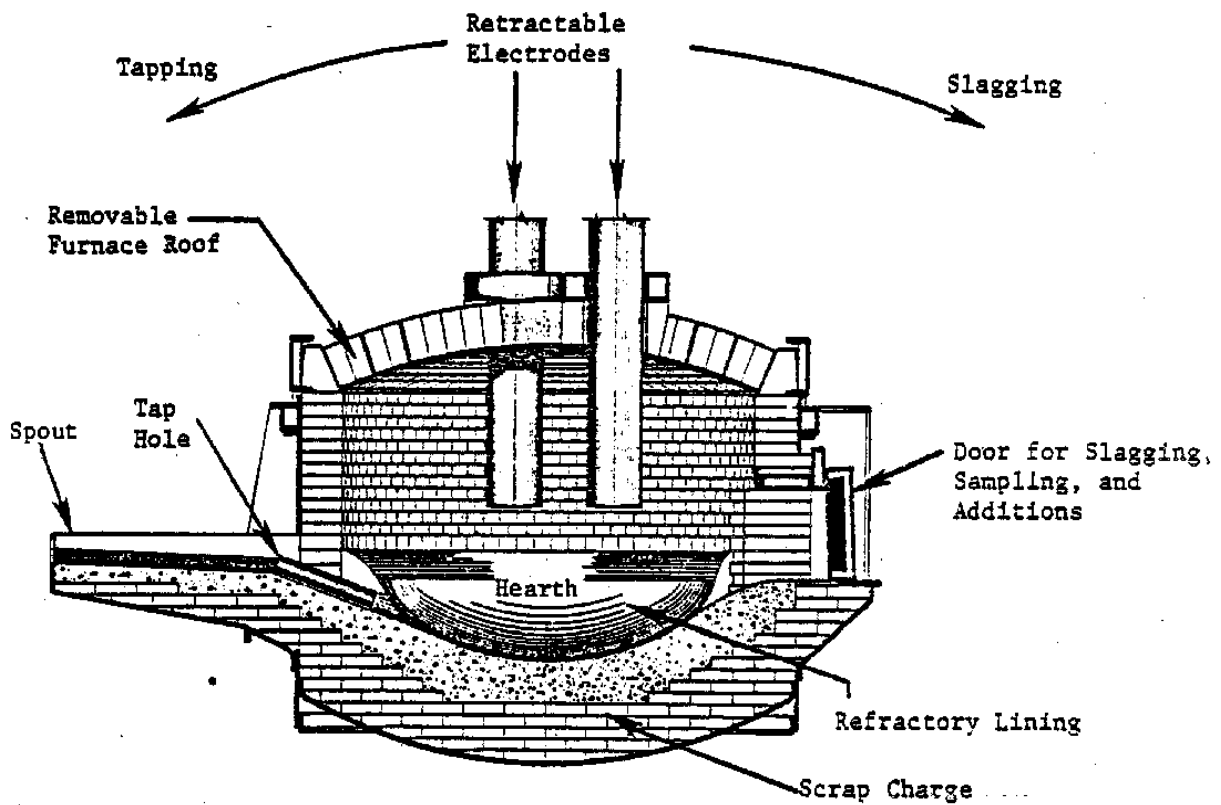

Figure 22. Typical electric arc steel furnace. ⁴⁸

A large variety of scrap is charged to EAFs. According to the Institute of Scrap Iron and Steel, all grades of scrap are to be almost free of dirt, nonferrous metals, and foreign material of any kind. Carbon steel shops typically use No. 1 and No. 2 grades of scrap, while specialty shops typically use No. 1 scrap, stainless scrap, and alloys such as ferromanganese, ferrochrome, high carbon chrome, nickel, molybdenum oxide, aluminum, manganese-silicon, and others.⁴⁸

Scrap size and bulk density vary from light scrap, such as machine turnings, to heavy scrap, such as ingot butts. Alloying materials that are not easily oxidized (such as copper, nickel, and molybdenum) and lime are charged before, or along with, the scrap metal charge. The lime is a fluxing agent to reduce the sulfur and phosphorus content in the molten steel. Depending on the desired carbon content of the steel and the finished product specifications, iron ore and coke may be charged prior to meltdown.⁴⁸

During the charging process, the scrap must be introduced into the furnace so that there is no damage to the refractory. If scrap pieces remain above the furnace ring, the pieces must be repositioned so that the roof can swing back into place for meltdown. This repositioning can be done by hand or by compressing the scrap with the charge bucket or other large mass of metal suspended from the crane. An oxygen lance is sometimes used to cut any pieces blocking the roof. After the roof is rotated into place, it is lowered onto the furnace in preparation for meltdown. Repositioning of the scrap delays the closing of the roof, allowing more emissions to escape from the furnace.⁴⁸

After the charging step, meltdown and refining occur. Once the roof is in place, the electrodes are mechanically lowered to within 2.5 cm (1 in.) of the scrap, and the power is turned on.⁵² When the current is applied to the electrodes, the electrodes are slowly lowered by automatic controls until they touch the scrap. During the first 3 to 5 minutes, an intermediate voltage is applied to the

charge to allow the electrodes to bore into the scrap, which, in effect, shields the sides and roof of the furnace from the heat of the arc.⁵² Melting is accomplished by the electrodes of the furnace and the metallic charge, by direct radiation from the furnace lining, and by the resistance of the metal between the arc paths. The arcs melt scrap directly beneath and around the electrodes, boring through the scrap charge and forming a pool of molten metal on the furnace hearth.^{48,52,53} The molten steel pool enhances meltdown by the radiation of heat from below into the cold scrap. After the initial period, the maximum voltage is applied in order to melt the charge as fast as possible. Before the scrap is entirely melted, a bank of refractory material (such as dolomite) is built in front of the slagging door to prevent the molten steel from spilling out the door.⁴⁸ Water-cooled glands are provided at the holes to cool the electrodes and minimize the gap between the electrodes and roof openings to reduce fugitive emissions, noise levels, electrode oxidation, and heat losses.

When the initial scrap charge is almost entirely molten, a backcharge of scrap may be added to the furnace (in some shops there may be more than one backcharge). Following the back charge, the roof is replaced, and electrodes are lowered and energized to melt the scrap. Near the end of the meltdown, oxygen lancing may be performed.⁴⁸ Oxygen lancing results in increased bath and gas temperatures, gas evolution, and generation of particulates. Oxygen is now used almost universally (instead of iron ore or mill scale) for boiling a heat of steel to flush out gases, mainly hydrogen and nitrogen.⁴⁸

During the meltdown, phosphorus, silicon, manganese, carbon, and other elements in the scrap metal are oxidized. Slag formation begins and is carefully monitored during the meltdown stages to control the chemical concentration and product quality. Basic EAFs use either single or double slagging operations depending upon the desired quality of the end product. The single slagging process uses an oxidizing slag that is formed by the addition of lime and coke

breeze (or other source of carbon) during the initial scrap metal charge. Other flux additions, such as fluorspar, silica, and ferrosilicon, may be made through the slag door. The double slagging process develops an oxidizing slag first, followed by a reducing slag. The initially formed oxidizing slag is raked off, with the power to the electrodes cut off, and is followed by additions of burnt lime, powdered coke, fluorspar, silica, sand, and ferrosilicon.⁵²

The final step in the EAF process is tapping. To tap a heat, the power is shut off and the electrodes are raised sufficiently to clear the bath. The furnace is tilted (sometimes as much as 45°), and the molten steel is tapped into a ladle. The ladle is placed close to the tapping spout to capture the batch of steel without excessive splashing and to reduce the exposure of the molten steel to the air and thus minimize excessive oxidation and cooling of the steel. Additions of ferromanganese, ferrosilicon, aluminum, and other alloying agents are sometimes made to the ladle to adjust the oxygen content of the steel.^{48,52} For certain steel alloys, chrome is added just prior to the tap to avoid oxidation of the chromium during meltdown.⁵⁴

After the molten steel is tapped into the ladle, the ladle is transferred to either an ingot teeming area, a continuous caster, or a refining vessel (in a specialty steel shop).

In the manufacture of stainless and other alloy steels, molten steel from the EAF is usually transferred to an argon-oxygen decarburization (AOD) vessel for further refining. AOD vessels are closed-bottom, refractory-lined, pear-shaped converter vessels with submerged tuyeres in the lower portion of the vessel (Figure 23). The AOD vessel is constructed of welded steel plate and mounted such that it may pivot for charging, slagging, and tapping. Argon, oxygen and/or nitrogen gases are blown through the tuyeres into the molten steel to adjust the bath temperature and chemistry and to cool and maintain the air passage in the shrouds and tuyeres.

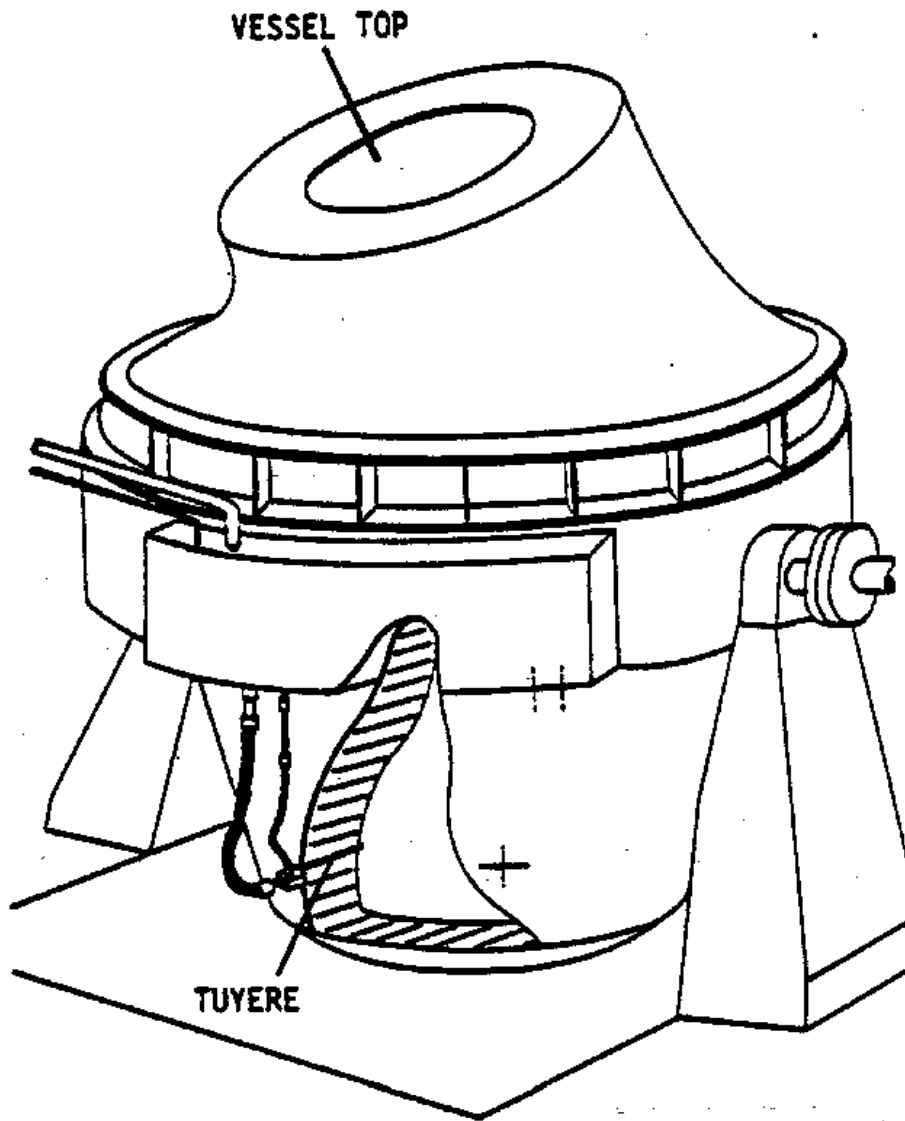

Figure 23. Argon-oxygen decarburization vessel.⁴⁸

To begin the AOD process, molten steel from an EAF is transferred by ladle to the AOD vessel, which rotates forward to accept the molten charge. When the charging operation is complete, typically in 1 to 8 minutes depending on the size of the AOD vessel, it is rotated back to an upright position so that refining can begin.⁵⁵ Before refining begins, additives such as lime or alloys are added to the molten steel with a crane-held charge pan or through a charge chute.⁴⁸

Refining is accomplished by blowing argon, oxygen, and/or nitrogen gases through the molten steel bath. The control of the gas mixture and flow is important to avoid the oxidation of alloys necessary for specialty steel production. As the heat progresses, alloys and fluxing agents are added to the molten steel in quantities that are determined by the chemical analyses performed on samples of the bath. The fluxing agents are typically lime and fluorspar, and the alloys include aluminum, chrome, nickel, manganese, boron, silicon, vanadium, and titanium. Limited amounts of scrap generated at the steel mill (home scrap) may also be periodically added to the vessel as additives to help reach the desired chemical makeup of the final product.⁴⁸

The carbon-chromium equilibrium relationship is very important in controlling the quantity of chromium in the final product. The amount of chromium in the melt is in an equilibrium relationship with the carbon. The carbon level is decreased with oxygen blowing; however, any excess chromium may also be oxidized and lost. The amount of chromium that the melt can retain decreases as the carbon content of the melt decreases.

The steel yield from an AOD vessel is very high. About 91 percent by weight of a typical charge of molten steel and fluxes to an AOD vessel is returned as product (specialty steel).^{55,56} The metallic yield, i.e., the steel tapped as a percent of the metal charge, is approximately 97 percent.⁴⁸

New methods or combinations of methods for refining the steel from EAFs, in addition to the use of AOD vessels, are currently being introduced. These secondary refining processes, collectively known as ladle refining, are being used to reduce the amount of refining that is performed in the EAF, allowing the EAF to be used strictly as a metal melting device. Argon bubbling is one technique where a gentle stream of argon is injected through a porous plug at the bottom of the ladle. This technique improves the quality of the steel and controls the composition of low-alloy and medium alloy grades of steel.⁵⁷ Another technique is vacuum-oxygen decarburization (VOD) that is used to reduce the carbon content in the steel without oxidizing the chromium. A consumable oxygen lance is inserted into the molten steel through the ladle cover. While the ladle is under reduced pressure, oxygen is blown into the melt. After the desired amount of oxygen is blown, the vacuum is continued while argon is bubbled through the melt so that the oxygen remaining in the steel can react with the remaining carbon. This technique takes 2 to 2.5 hours to refine the molten steel.⁴⁸

Emission Factors--

The quantity and type of emissions from an EAF depend upon many factors: furnace size, type and composition of scrap, quality of scrap, type of furnace, process melting rate, number of backcharges, refining procedure, tapping duration, and melt temperature.⁵⁸ The majority of the emissions from EAFs are ferrous and nonferrous oxide particulates. Furnace emissions are the highest during meltdown and refining operations, but charging and tapping emissions can also be significant, especially if ladle additions are made during the tap and dirty scrap is charged. The charging and tapping emissions represent approximately 5 percent each of the total emissions during a heat.⁵⁸ Increases in electrical power to the furnace and the use of oxygen lancing will cause emissions to increase during meltdown and refining.⁴⁸

Electric arc furnace emissions are comprised of both a process and fugitive component. Process emissions include those generated at the furnace when the furnace roof is closed (e.g., during melting and

refining) as well as those generated when the primary emission capture device (e.g., DEC system, side draft hood) is operative. Emissions generated when the furnace roof is open (e.g., during charging) or when the primary emission capture device cannot operate (e.g., during charging and tapping) are considered to be fugitive emissions.⁴⁸

Process emissions from the meltdown operation consist of metallic and mineral oxide particulates, carbon monoxide, and hydrocarbons generated from the vaporization of iron and the transformation of mineral additives.^{48,58} Trace constituents (including hexavalent chromium) are emitted in particulate form from EAFs.^{48,59} During the melting process, emissions escape through electrode holes, the slag door, the roof ring, and sometimes the tap spout.⁴⁸ Most process emissions can be largely eliminated by the control technology discussed later in this section.

Fugitive emissions from charging the open furnace are more difficult to control. The level of charging emissions varies depending on the cleanliness and composition of the scrap. Most charging emissions result from (1) vaporization of oil, grease, or dirt introduced with the charge, (2) oxidation of organic matter that may adhere to the scrap, and (3) the vaporization of water from wet scrap.^{48,54,58} Emissions are made up of particulate matter, carbon monoxide, hydrocarbon vapors, and soot.⁵⁸ If particles of the scrap charge are emitted, they may contain trace amounts of chromium. Backcharging produces a large eruption of reddish-brown fumes. Fugitive backcharging emissions are higher than fugitive emissions from the initial charge because of the intense reaction that occurs due to the heat of the molten steel in the furnace.⁴⁸

Fugitive emissions are also produced during tapping. These fumes consist of iron oxides as well as other oxide fumes resulting from alloys that are added to the ladle.⁴⁸ Since chromium may be added at this point to stainless and alloy steels, chromic oxide can be emitted.⁴⁸

Particulate emissions from an AOD vessel are comprised of both ferrous and nonferrous oxides. The quantity and type of emissions from an AOD vessel depend upon several factors: the quality of the molten steel charge, the quality of the final product desired, and the types and quantity of alloys added. Almost all the emissions occur during the blowing (refining) stage, with a dense cloud occurring when the concentration of oxygen in the gas stream is the highest at the beginning of the heat. When the AOD vessel is in a tilted position for temperature checks and sample-taking, there are almost no emissions because no gases are blown through the molten steel. The charging and tapping emissions are minimal because the charge is made to an empty vessel, and the tap occurs after the carbon - content has been greatly reduced. Since AOD vessels are often used to refine stainless steels⁴⁸ containing 12 to 25 percent chromium, the chromium content of particulate emissions from AODs is significant.

Fabric filters are the most widely used control device on EAFs and the only system used on AOD vessels. Fabric filters are the most effective control technology for the removal of small particles generated by EAFs and AOD vessels. They have been shown to be as effective at removing chromium as at removing total particulates. Both pressure type and suction type fabric filters are used. Most bags are constructed of a Dacron polyester blend with an air-to-cloth ratio of about 3:1 and a pressure drop of 7.6 - 12.7 cm (3 to 5 in) water. Dust collected by fabric filters is often recycled for the recovery of chromium, nickel, iron, and/or zinc. Some plants pelletize the dust and feed it back to their furnaces. An ESP is known to be in use at one EAF shop, but none have been installed since 1974. Wet scrubbers are used by less than 2 percent of the existing EAF units.⁴⁸ These control devices are generally less efficient at particulate (and therefore chromium) removal than fabric filters.

The capture of EAF and AOD vessel exhaust is a very important aspect of emissions control. The following systems have been used at EAF shops to capture emissions and route them to a suitable control device.⁴⁸

1. direct-shell evacuation control system (DEC)
2. side craft hoods
3. canopy hoods
4. partial furnace enclosure (PFE)
5. total furnace enclosure (TFE)
6. tapping hoods
7. scavenger duct system
8. roof monitors
9. building evacuation

Each system and its advantages or disadvantages are briefly described below. For each system, the chromium capture efficiency can be assumed to be similar to the reported total particulate emissions capture efficiency because chromium exists in the emissions as a particulate.

A DEC system is illustrated in Figure 24. A duct attaches to a hole in the roof and when the roof is in place, it joins a second duct leading to the emissions control device. The DEC withdraws 90 to 100 percent of melting and refining process emissions before they escape the furnace. However, when the furnace is tilted or the roof is rotated aside for charging, the DEC system is ineffective.^{48,60} The DEC system has been widely used in the industry for many years and can be used on EAFs producing any type of steel.⁴⁸

Figure 25 shows a side draft hood. This system also captures emissions only during melting and refining. It is mounted to the EAF roof, with one side open to avoid restricting the movement of the electrodes. Particulate (and therefore chromium) emissions capture is estimated to be between 90 and 100 percent. The side draft hood is not as widely used as the DEC and is typically used only on small furnaces because of the larger exhaust volume and higher operating costs.⁴⁸

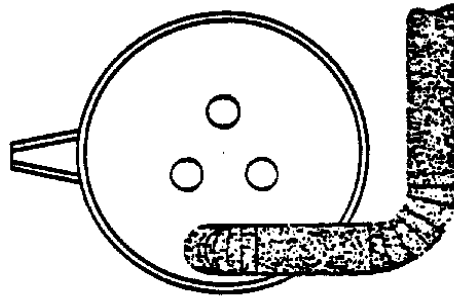

A. PLAN

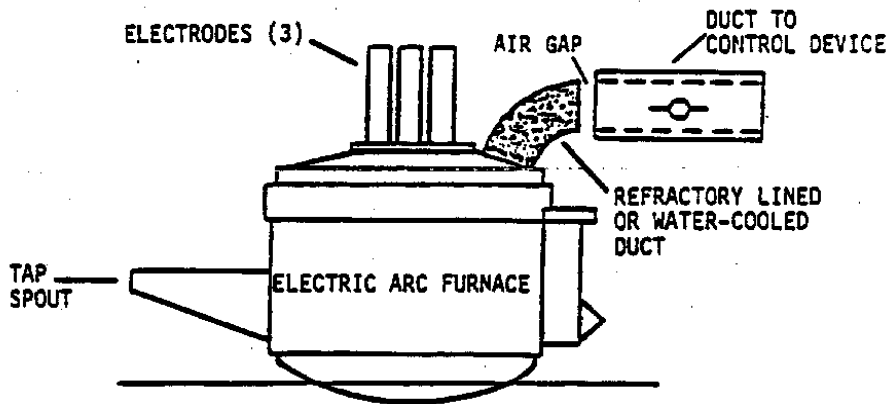

B. ELEVATION

Figure 24. Direct-shell evacuation control (two views).⁴⁸

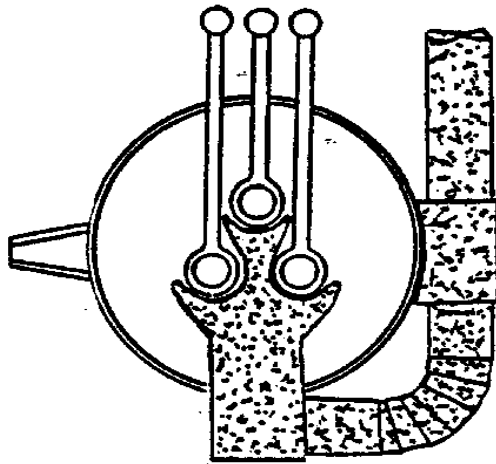

A. PLAN

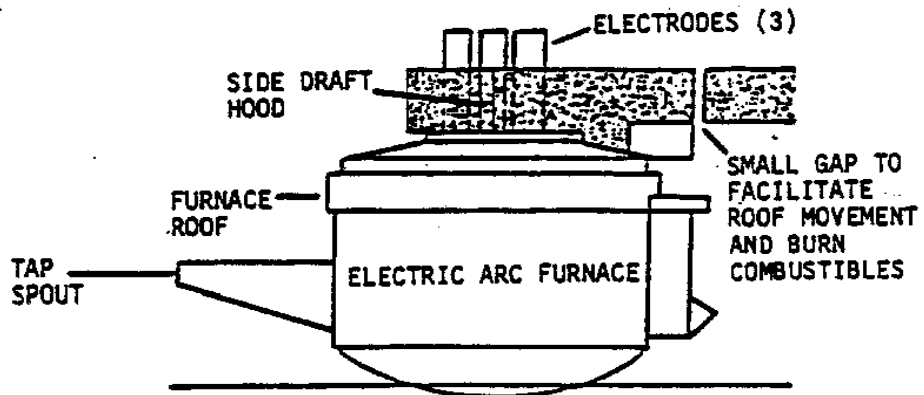

B. ELEVATION

Figure 25. Side draft hood (two views).⁴⁸

The canopy hood system, shown in Figure 26, involves one or more hoods suspended from the shop roof directly above each furnace. The hood must be high enough to provide clearance for crane movement during charging and space for upward movement of the electrodes. The system is used alone to capture both process and fugitive emissions, or in conjunction with another process emissions capture device. Thermal currents from the hot furnace help chromium-containing particulates rise to the hood to be captured; however, cross-drafts and passage of the crane may disrupt the path of the emission stream and cause it to escape capture. Partitions may be installed to reduce cross-drafts. Capture efficiency of a single canopy hood is typically 75 to 85 percent. Segmented (sectioned) canopy hoods have a higher efficiency (85 to 95 percent).^{48,61-64} Hoods are one of the oldest and most widely used collection devices.⁴⁸

The partial furnace enclosure (PFE), pictured in Figure 27, has walls on three sides of the furnace area that act as a chimney directing fugitive emissions from charging and tapping to a canopy hood. They are often used in conjunction with another process emission capture system. Partial furnace enclosures are easier to install and less expensive than total furnace enclosures. They allow the operators to see the furnace during charging, and any explosions are vented out the front of the enclosure rather than damaging the enclosure. Crane passage above the furnace can still disrupt the emission plume. The amount by which PFEs increase the capture efficiency of canopy hoods is not documented.⁴⁸ They are installed at several facilities on EAFs ranging in size from 154 Mg (170 tons) to 204 Mg (225 tons).⁴⁸

Total furnace enclosures (TFEs) completely surround the furnace with a metal shell that acts to contain all charging, melting and refining, slagging, and tapping emissions (Figure 28). The air flow required is only 30 to 40 percent of that required for a canopy hood system. The front charge doors are closed during charging after the crane and charge bucket have been admitted. A duct at the top of the enclosure removes charging and melting/refining emissions. A local

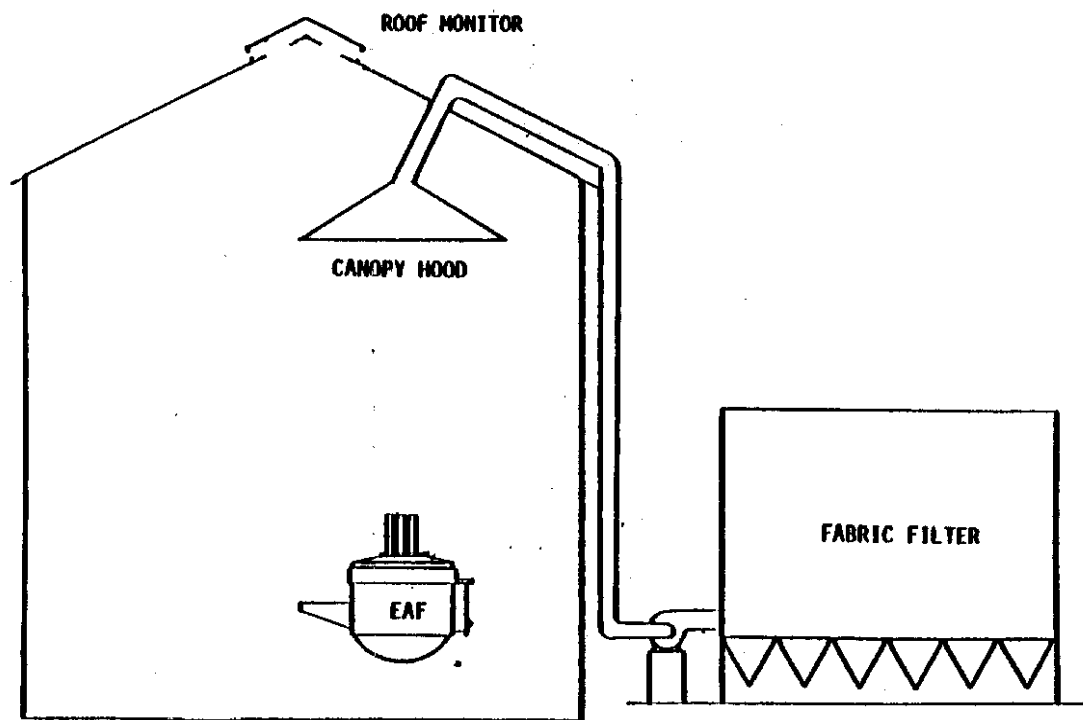

Figure 26. Canopy hood capture system.⁴⁸

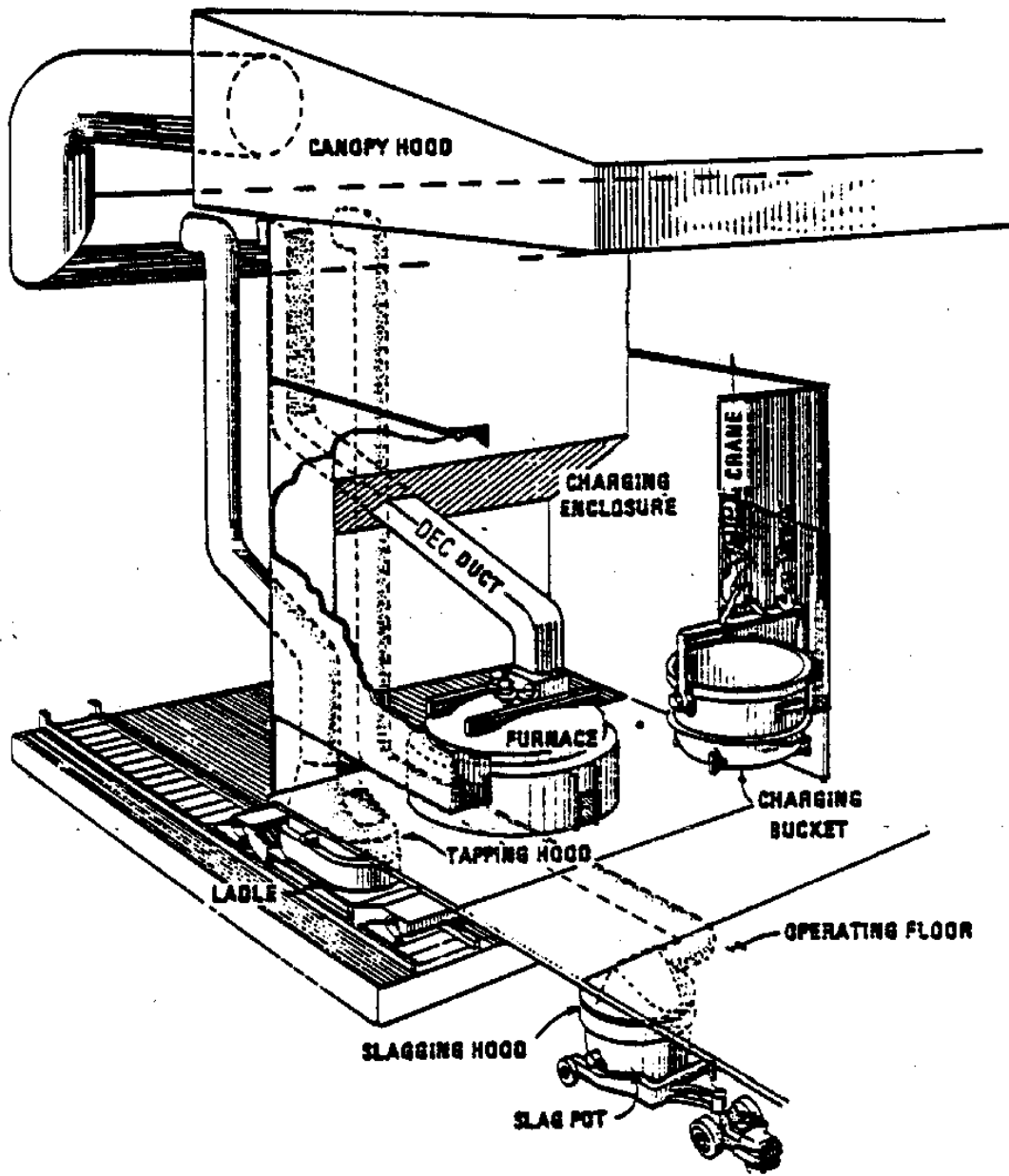

Figure 27. Partial furnace enclosure.⁴⁸

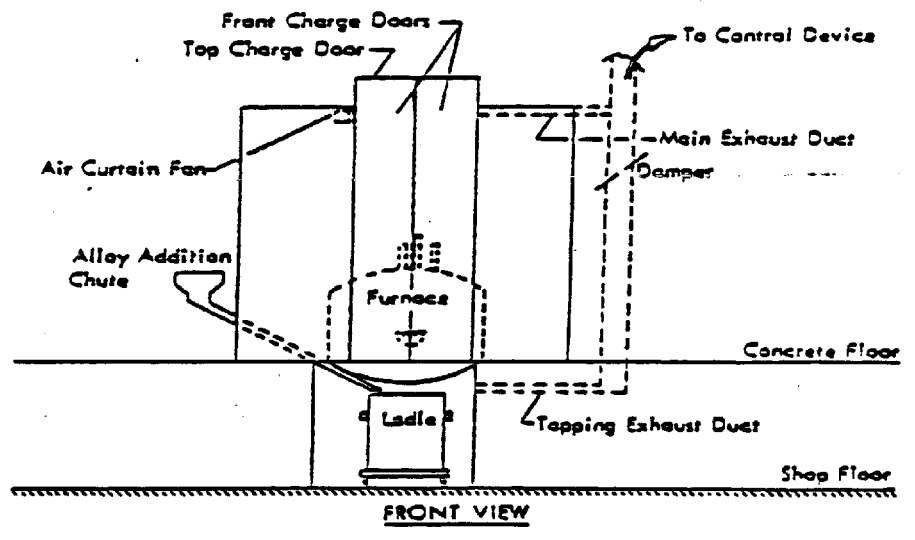
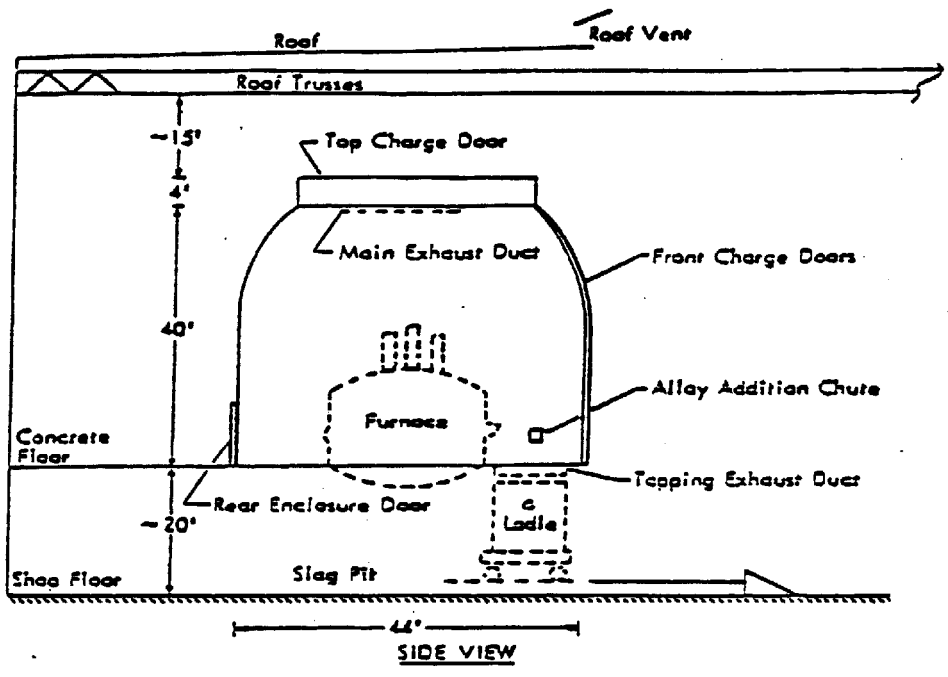

Figure 28. Total furnace enclosure.⁴⁸

hood under the enclosure collects emissions from slag tapping. Tapping emissions are collected from a duct adjacent to the tapping ladle. Emissions capture efficiency is between 90 and 100 percent. Total furnace enclosures were installed on at least five relatively small EAF furnaces in the United States between 1976 and 1981. A 165 Mg (182 ton) medium sized furnace in Italy was fitted with a TFE in 1980, and should provide operational data on the use of TFEs on larger furnaces.^{48,65}

Tapping hoods are movable or stationary hoods located immediately above the tapping ladle when the tapping operation is in progress. Since the hood is close fitting, it is more efficient than a canopy hood. Tapping hoods are receiving increased usage throughout the industry to supplement capture by TFE's, PFE's, canopy hoods, and DEC's.^{48,60}

A scavenger duct system consists of small auxiliary ducts that are located above the main canopy hood(s) built into a closed shop roof. A relatively low flow rate is maintained through these ducts to capture chromium-containing fugitive emissions not captured by the canopy hood. This system would provide greater capture efficiency than just a canopy hood, but can only be used with a closed or semi-closed roof. The extent of use is unknown.⁴⁸

Roof monitor configurations can be open, open except over the furnace, or closed over the entire melt shop. A variation of the closed roof shop involves a louvered roof monitor that is mechanically controlled to allow for closing the louvers during periods of fugitive emissions. Advantages of an open roof include natural ventilation of the shop. However, a closed roof promotes more effective capture of emissions by canopy hoods or scavenger ducts. Louvered or partially closed roofs allow advantages of both systems.⁴⁸

A building evacuation system uses ductwork at the peak of a closed roof shop to collect all emissions from the shop operations. A 25 percent greater air flow is required than with a canopy hood, however all shop emissions are captured. Capture efficiency for particulate matter, and therefore chromium, is 95 to 100 percent. The capture rate, however, is slower than with a canopy hood. Several plants utilize this type of emissions control.^{48,60,65}

Some typical combinations of the previously described emissions capture techniques for EAFs and the efficiencies of these combinations are shown in Table 20.

Emissions from AOD vessels occur primarily when the vessel is in an upright position. These emissions exert a strong upward thermal lift. They are typically captured using two types of systems, a diverter stack with canopy hood system and a close-fitting hood with canopy hood system.

The diverter stack (Figure 29) is located about 1.5 m (5 ft) above the AOD vessel and can be fixed in position or movable. It reduces cross-draft and is narrower at the top, which accelerates the AOD vessel emissions (containing chromium) toward the canopy hood.

A close fitting hood is pictured in Figure 30. It is situated 0.3 to 0.6 m (1 to 2 ft) above the AOD vessel and can be moved out of the way during charging and tapping. Refining emissions are captured by the close fitting hood and any fugitives are captured by the canopy hood. Most AOD installations use this system because it achieves more efficient capture with lower air flow volumes than the diverter stack system.^{48,66}

Table 21 shows the estimated fugitive emission reduction efficiencies of typical control combinations used at AOD installations.

TABLE 20. FUGITIVE EMISSIONS CAPTURE TECHNOLOGY COMBINATIONS
(CARBON AND SPECIALTY STEEL EAF) ⁴⁸

Combination	Fugitive emissions capture equipment ^a	Estimated fugitive emission capture ^b (percent)
1	Single canopy hood, open roof monitor.	75-85
2	Segmented canopy hood, closed roof (over furnace)/open roof monitor.	85-95
3	Single canopy hood, local tapping hood, local slagging hood, closed roof (over furnace)/open roof monitor.	85-95
4	Segmented canopy hood, scavenger duct, cross-draft partitions, closed roof (over furnace)/open roof monitor.	90-95
5	Single canopy hood, total furnace enclosure, closed roof (over furnace)/open roof monitor.	90-95
6	Segmented canopy hood, scavenger duct, cross-draft partitions, closed roof monitor.	95-100

^a Direct-shell evacuation control (DEC) system used for process emissions capture in all cases in addition to equipment listed above for fugitive emissions capture.

^b Estimate based on engineering judgment. These figures apply to total particulate emissions; however, an equivalent level of capture should be achieved for chromium emissions.

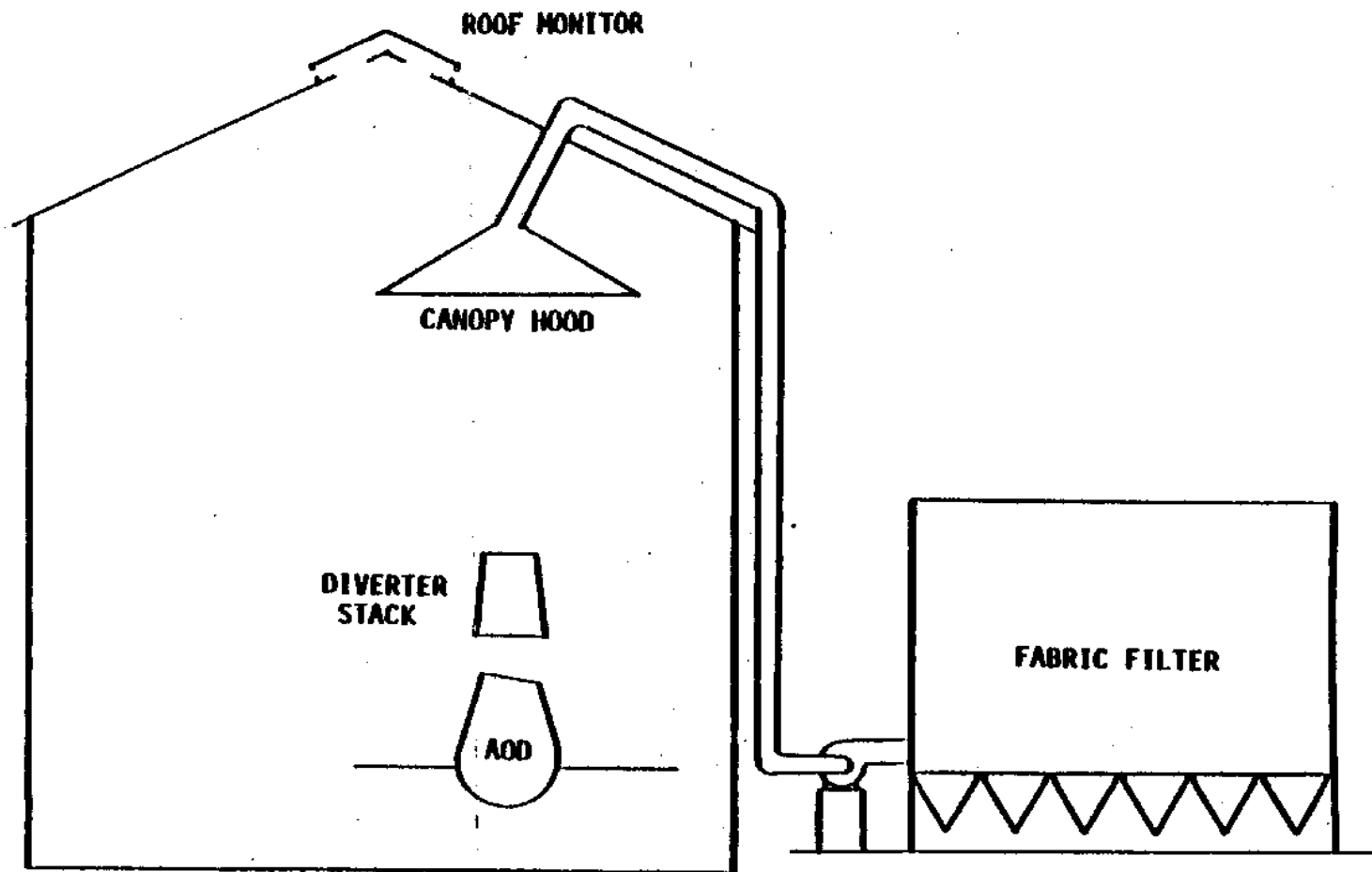

Figure 29. Diverter stack with canopy hood.⁴⁸

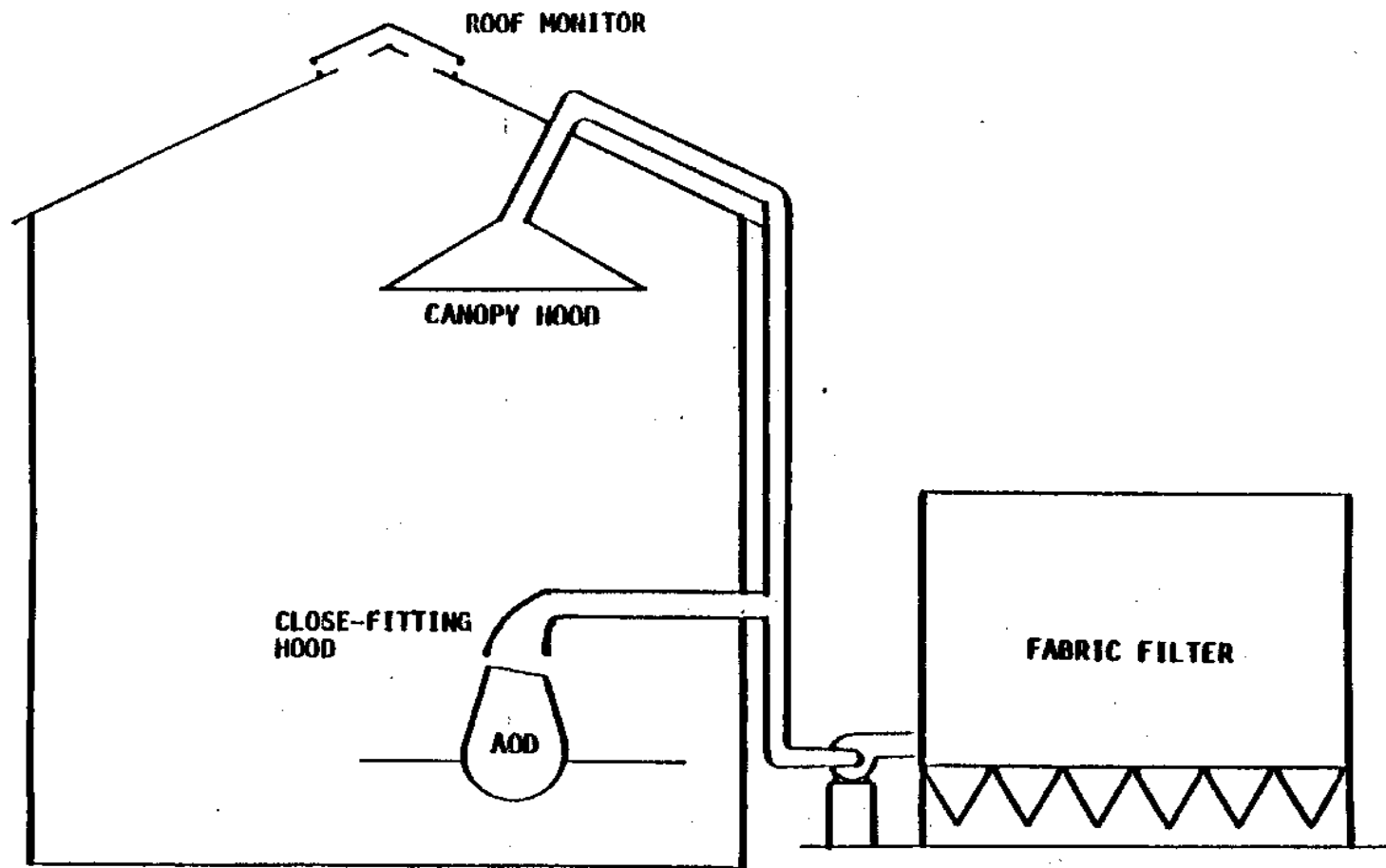

Figure 30. Close-fitting hood with canopy hood.⁴⁸

TABLE 21. FUGITIVE EMISSIONS CAPTURE TECHNOLOGY COMBINATIONS
(SPECIALTY STEEL AOD) ⁴⁸

Combination	Fugitive emissions capture equipment ^a	Estimated fugitive emission capture ^b (percent)
1	Single canopy hood, diverter stack, open roof monitor.	75-85
2	Single canopy hood, scavenger duct, closed roof (over vessel)/open roof monitor.	85-95
3	Single canopy hood, scavenger duct, cross-draft partitions, closed roof (over vessel)/open roof monitor.	90-95
4	Segmented canopy hood, scavenger duct, cross-draft partitions, closed roof monitor.	95-100

^a Close-fitting hood used for process emissions capture on combinations 2,3, and 4. All emissions are considered fugitive for combination 1.

^b Estimate based on engineering judgment. These figures apply to total particulate emissions; however, equivalent level of capture should be achieved for chromium emissions.

Table 22 lists uncontrolled chromium emissions factors for electric arc furnaces producing different types of steel and for AOD vessels. The percent chromium in electric arc furnace dust was determined from testing of 33 samples of electric arc furnace dust from 25 steel plants.⁶⁷ The chromium emission factors in kg/Mg and lb/ton were calculated assuming total uncontrolled particulate emissions of 7.5 to 22.5 kg/Mg (15 - 45 lb/ton).^{48,67} The chromium emission factors for AOD vessels were reported in reference 48 but the extent of testing behind that figure is unknown. Table 23 shows the chromium content of dust emitted from an EAF during different steps of operation.⁵⁴ Chromium is emitted from EAFs and AODs primarily in the form of chromic oxide (Cr_2O_3).^{48,54}

Chromium emission factors after controls are not reported in the literature. However, chromium is typically controlled by fabric filters to the same degree as total particulates. Controlled chromium emission factors would depend on the efficiency of capture of fugitive and process emissions as well as the efficiency of the fabric filter. Particulate collection and control efficiencies of 99 percent have been reported using some of the control technologies previously discussed,⁴⁸ and chromium removal efficiency is assumed to be similar.

Source Locations--

In 1981, there were 322 EAFs in the United States, which were operated by 87 companies in 125 locations. The locations of these plants are listed in Table 24.^{48,68-70} Table 25 shows the distribution of these plants by State.

In 1981, there were 27 AOD vessels operated by 19 companies at 23 locations in 9 states. These locations are listed in Table 26.^{48,71}

TABLE 22. UNCONTROLLED CHROMIUM EMISSION FACTORS FOR ELECTRIC ARC FURNACES (EAFs) AND ARGON-OXYGEN DECARBURIZATION VESSELS (AODs) ^{48,67}

Type of Furnace	Type of Products	Weight % of Chromium in Particulate Emissions	Chromium Emission Factors, kg/Mg (lb/ton) of Steel Produced ^a
EAF	Stainless Steel and Specialty Alloys	10.6 ^b	0.80 - 2.4 (1.6 - 4.8)
EAF	Mixed Products Including Stainless Steel and/or Specialty Alloys	2.22 ^b	0.17 - 0.50 (0.33 - 1.0)
EAF	Carbon and Alloy Steel	0.20 ^c	0.015 - 0.045 (0.03 - 0.09)
EAF	Carbon Steel	0.20 ^d	0.015 - 0.045 (0.03 - 0.09)
AOD	Stainless and Specialty Alloys	6.6 ^e	0.43 - 0.62 (0.87 - 1.2)

^a All factors expressed in terms of total elemental chromium and represent emissions after capture equipment but prior to controls. Emissions are known to contain chromium in both trivalent and hexavalent oxidation states.

^b Average of six samples from different furnaces.

^c Average of seven samples from different furnaces.

^d Average of ten samples from different furnaces.

^e Average of two samples from different vessels.

TABLE 23. CHROMIUM CONTENT OF ELECTRIC ARC FURNACE DUST FOR EACH STEP OF FURNACE OPERATION AT ONE FACILITY 54

Phase	Weight % Chromium in Dust ^a
Melting	1.32
Oxidizing	1.32
Oxygen Lancing	0.86
Reduction	0.53

^a Chromium percentages were measured and are reported as chromic oxide(Cr_2O_3).

TABLE 24. LOCATIONS OF ELECTRIC ARC FURNACES IN THE UNITED STATES IN 1981⁴⁸

PLANT/LOCATION	PLANT/LOCATION	PLANT/LOCATION
<p>AL TECH SPECIALITY STEEL CORP. Watervliet, N.Y.</p> <p>ALLEGHENY LUDLUM STEEL CORP. Brackenridge, PA.</p> <p>ARMCO, INC. Baltimore works Baltimore, Md.</p> <p>Butler Works Butler, Pa.</p> <p>Houston Works Houston, Tex.</p> <p>*Kansas City Works Kansas City, Mo.</p> <p>*National Supply Division Torrance, Calif.</p> <p>ATLANTIC STEEL CO. *Atlantic Works Atlanta, Ga.</p> <p>*Cartersville Works Cartersville, Ga.</p> <p>AUBURN STEEL CO. Auburn, N.Y.</p> <p>BABCOCK & WILCOX CO. Beaver Falls, Pa.</p> <p>BAYOU STEEL CORP. New Orleans, La.</p> <p>BETHLEHEM STEEL CORP. *Bethlehem Plant Bethlehem, Pa.</p> <p>*Steelton Plant Steelton, Pa.</p> <p>*Johnstown Plant Johnstown, Pa.</p>	<p>BETHLEHEM STEEL CORP. (cont.) *Los Angeles Plant Los Angeles, Calif.</p> <p>*Seattle Plant Seattle, Wash.</p> <p>BORDER STEEL MILLS, INC. El Paso, Tex.</p> <p>BW STEEL, INC. Chicago Heights, Ill.</p> <p>CABOT CORPORATION Stellite Div. Kokomo, Ind.</p> <p>CAMERON IRON WORKS, INC. Houston, Tex.</p> <p>CARPENTER TECHNOLOGY CORP. *Steel Division Bridgeport, Conn.</p> <p>*Reading Plant Reading, Pa.</p> <p>CASCADE ROLLING MILLS McMinnville, Oreg.</p> <p>CCS BRAEBURN ALLOY STEEL DIV. Lower Burrell, Pa.</p> <p>THE CECO CORP. *Lemont Manufacturing Co. Lemont, Ill.</p> <p>*Milton Manufacturing Co. Milton, Pa.</p> <p>CF&I STEEL CORP. Pueblo, Colo.</p> <p>CHAPARRAL STEEL CO. Midlothian, Tex.</p> <p>CHARTER ELECTRIC MELTING CO. Chicago, Ill.</p>	<p>COLT INDUSTRIES *Crucible Stainless Steel Div. Midland, Pa.</p> <p>*Crucible Specialty Metals Div. Syracuse, N.Y.</p> <p>COLUMBIA TOOL STEEL CO. Chicago Heights, Ill.</p> <p>CONNORS STEEL CO. *Birmingham Works Birmingham, Ala.</p> <p>*Huntington Works Huntington W. Va.</p> <p>COPPERWELD STEEL CO. Warren, Ohio</p> <p>CYCLOPS CORP. *Empire Detroit Steel Div. Mansfield, Ohio</p> <p>*Universal Cyclops Specialty Steel Bridgeville, Pa.</p> <p>EASTERN STAINLESS STEEL CO. Baltimore, MD</p> <p>EDGEWATER STEEL CORP. Oakmont, PA</p> <p>ELLECTRALLOY CORP. Oil City, Pa.</p> <p>FINKLE & SONS Chicago, Ill.</p> <p>FLORIDA STEEL *Charlotte Mill Charlotte, NC</p> <p>*Indiantown Mill Indiantown, FL</p>

TABLE 24. (CONTINUED) LOCATIONS OF ELECTRIC ARC FURNACES IN THE UNITED STATES IN 1981⁴⁸

PLANT/LOCATION	PLANT/LOCATION	PLANT/LOCATION
<p>*Baldwin Mill Baldwin, Fla.</p> <p>*Tampa Mill Tampa, Fla.</p> <p>*Jackson Mill Jackson, Tenn.</p> <p>GREEN RIVER STEEL Owensboro, Ky.</p> <p>GUTERL SPECIAL STEEL CORP. Lockport, N.Y.</p> <p>HAWAIIAN WESTERN STEEL LTD. Ewa, Hawaii</p> <p>HUNT STEEL CO. Youngstown, Ohio</p> <p>HURRICANE INDUSTRIES INC. Sealy, Tex.</p> <p>ILLINOIS BIRMINGHAM BOLT Kankakee, Ill.</p> <p>INGERSOL JOHNSON STEEL CO. New Castle, Ind.</p> <p>INGERSOL RAND-OIL FIELD PROD. Pampa, Texas</p> <p>INLAND STEEL Co. East Chicago, Ind.</p> <p>INTERCOASTAL STEEL CORP. Chesapeake, Va.</p> <p>INTERLAKE, INC. Hoeganaes Corporation Gallatin, Tenn.</p> <p>ITT HARPER Morton Grove, Ill.</p>	<p>JARSCO Roebbing, N.J.</p> <p>JESSOP STEEL CO. Washington Works Washington, Pa.</p> <p>JONES & LAUGHLIN STEEL CORP. *Cleveland Works Cleveland, Ohio</p> <p>*Pittsburgh Works Pittsburgh, Pa.</p> <p>*Warren Works Warren, Mich.</p> <p>EARLE M. JOGENSEN CO. Seattle, Wash.</p> <p>JOSLYN STAINLESS STEELS Fort Wayne, Ind.</p> <p>JUDSON STEEL CORP. Emeryville, Calif.</p> <p>KENTUCKY ELECTRIC STEEL Co. Ashland, Ky.</p> <p>KEYSTONE CONSOLIDATED INDUSTRIES, INC Keystone Group Steel Works Peoria, Ill.</p> <p>KNOXVILLE IROM CO. Knoxville, Tenn.</p> <p>KORF INDUSTRIES *Georgetown Steel Corp. Georgetown, S.C.</p> <p>*Georgetown Texas Steel Corp. Beaumont, Tex.</p> <p>LACLEDE STEEL CO. Alton, Ill.</p> <p>LATROBE STEEL CO. Latrobe, Pa.</p>	<p>LONESTAR STEEL CO. Lone Star, Tex.</p> <p>LUKENS STEEL Coatsville, Pa.</p> <p>MARATHON LE TOURNEAU CO. Longview, Tex.</p> <p>MARATHON STEEL CO. Tempe, Ariz.</p> <p>MARION STEEL CO. Marion, Ohio</p> <p>McCLOUTH STEEL CORP. Trenton, Mich.</p> <p>MISSISSIPPI STEEL DIV. Flowood Works Flowood, Miss.</p> <p>NATIONAL FORGE CO. *Erie Plant Erie, Pa.</p> <p>*Irvine Forge Division Irvine, Pa.</p> <p>NATIONAL STEEL CORP. Great Lakes Steel Div. Ecorse, Mich.</p> <p>NEW JERSEY STEEL & STRUCTURE CORP. Sayerville, N.J.</p> <p>NEWPORT STEEL Newport, Ky.</p> <p>NORTH STAR STEEL CO. *St. Paul Plant St. Paul, Minn.</p> <p>*Monroe Plant Monroe, Mich.</p> <p>*Wilton Plant Wilton, Iowa</p>

TABLE 24. (CONTINUED) LOCATIONS OF ELECTRIC ARC FURNACES IN THE UNITED STATES IN 1981⁴⁸

PLANT/LOCATION	PLANT/LOCATION	PLANT/LOCATION
NORTHWEST STEEL ROLLING HILLS, INC. Kent, Wash.	REPUBLIC STEEL CORP. *Central Alloy Works Canton, Ohio	TELEDYNE VASCO Latrobe, Pa.
NORTHWESTERN STEEL & WIRE CO. Sterling, Ill.	*South Chicago Works South Chicago, Ill.	TENNESSEE FORGING STEEL CORP. Harriman Works Harriman, Tenn.
NUCOR CORP. *Darlington Mill Darlington, S.C.	ROANOKE ELECTRIC STEEL CORP. Roanoke, Va.	TEXAS STEEL CO. Fort Worth, Tex.
*Jewett Mill Jewett, Tex.	ROBLIN STEEL CO. Dunkirk Works Dunkirk, N.Y.	TIMKEN CO. Steel and Tube Div. Canton, Ohio
*Norfolk Mill Norfolk, Nebr.	ROSS STEEL WORKS Amite, La.	UNION ELECTRIC STEEL CORP. Burgettstown, Pa.
*Plymouth Mill Plymouth, Utah	ROUGE STEEL CO. Dearborn, Mich.	UNITED STATES STEEL CORP. *Fairless Work Fairless Hills, Pa.
OREGON STEEL MILLS Portland, Oreg.	SHARON STEEL CORP. Sharon, Pa.	UNITED STATES STEEL CORP. *Johnstown-Center Works Johnstown, Pa.
OWENS ELECTRIC STEEL COMPANY Cayce, S.C.	SHEFFIELD STEEL CORP. Sand Springs, Okla.	*National Duquesne Works Duquesne, Pa.
PENN-DIXIE STEEL CORP. Kokomo Plant Kokomo, Ind.	SOULE STEEL CO. Carson Works Carson, Calif.	*South Works South Chicago, Ill.
PHOENIX STEEL CORP. Plate Div. Claymont, Del.	SOUTHERN UNITED STEEL CORP. Birmingham, Ala.	*Texas Works Baytown, Tex.
QUANTEX CORP. *Mac Steel Michigan Div. Jackson, Mich.	STANDARD STEEL ENTERPRISE Freedom Forge Corp. Burnham, Pa.	WASHINGTON STEEL CO. Fitch Works Houston, Pa.
*Mac Steel Arkansas Div. For Smith, Ark.	Latrobe, Pa.	WITTEMAN STEEL MILLS Fontana, Calif.
RARITAN RIVER STEEL CO. Perth Amboy, N.J.	STRUCTURAL METALS, INC. Sequin, Tex.	
RAZORBACK STEEL CORP. Newport, Ark.	TAMCO Etiwanda, Calif.	

Note: This listing is subject to change as market conditions change, facility ownership changes, plants are closed down, etc. The reader should verify the existence of particular facilities by consulting current listings and/or the plants themselves. The level of chromium emissions from any given facility is a function of variables such as capacity, throughput, and control measures.

TABLE 25. LOCATION OF STEEL PLANTS WITH EAFs AND AOD VESSELS --
1981 ⁴⁸

State	Plants	
	EAF	AOD vessel
Alabama	3	
Arizona	1	
Arkansas	1	
California	6	
Colorado	1	
Connecticut	1	1
Delaware	1	
Florida	3	
Georgia	2	
Hawaii	1	
Illinois	11	1
Indiana	5	3
Iowa	1	
Kentucky	3	
Louisiana	2	
Maryland	2	2
Michigan	6	1 ^a
Minnesota	1	
Mississippi	1	
Missouri	1	
Nebraska	1	
North Carolina	1	
New Jersey	2	
New York	5	2
Ohio	6	2
Oklahoma	1	
Oregon	2	
Pennsylvania	27	10
Rhode Island	1	
South Carolina	3	
Tennessee	4	
Texas	12	
Utah	1	
Virginia	2	
Washington	3	1
West Virginia	1	
	125	23

^a Another plant in Michigan has not operated its AOD vessel since it was installed in 1977.

TABLE 26. LOCATIONS OF ARGON-OXYGEN DECARBURIZATION (AOD) VESSELS IN THE UNITED STATES IN 1981 ⁴⁸

Plant/Location	Plant/Location
AL TECH SPECIALTY STEEL CORP. Watervliet, K.Y.	EASTERN STAINLESS STEEL CO. Baltimore, Md.
ALLEGHENY LUDLUM STEEL CORP. Brackenridge, Pa.	ELECTRALLOY CORP. Oil City, Pa.
ARMCO, INC. - Baltimore Works Baltimore, Md. - Butler Works Butler, Pa.	INGERSOL JOHNSON STEEL COL. New Castle, Ind.
BABCOCK AND WILCOX CO. Beaver Falls, Pa.	JESSOP STEEL CO. Washington Works Washington, Pa.
CABOT CORP. Stellite Div. Kokomo, Ind.	JONES AND LAUGHLIN STEEL CORP. Warren Works Warren, Mich.
CARPENTER TECHNOLOGY CORP. - Steel Div. Bridgeport, Conn. - Reading Plant Reading, Pa.	EARL M. JORGENSEN STEEL CO. Seattle, Wash.
CRUCIBLE, INC. - Stainless Steel Div. Midland, Pa. - Specialty Metals Div. Syracuse, N.Y.	JOSLYN STAINLESS STEELS Fort Warn, Ind.
CYCLOPS CORP. - Universal Cyclops Bridgeville, Pa. - Empire-Detroit Div. Mansfield, Ohio	MCLOUTH STEEL CORP. Trenton, Mich.
	REPUBLIC STEEL CORP. Central Alloy Works Canton, Ohio
	STANDARD STEEL DIV. Burnham, Pa.
	U.S. STEEL CO. Specialty Steel South Works Chicago, Ill.
	WASHINGTON STEEL CO. Fitch Works Houston, Pa.

Note: This listing is subject to change as market conditions change, facility ownership changes, plants are closed down, etc. The reader should verify the existence of particular facilities by consulting current listings and/or the plants themselves. The level of chromium emissions from any given facility is a function of variables such as capacity, throughput, and control measures. It should be determined through direct contacts with plant personnel.

The Iron and Steel Institute is a source of current information on plant locations. The steel industry, including EAF and AOD shops, is classified under SIC code 3312.

Basic Oxygen Process Furnaces

Chromium can be emitted from basic oxygen process furnaces (BOPFs) because it may be a contaminant of scrap and pig iron feed, and because it may be added to furnaces which produce alloy steels. Basic oxygen process furnaces have recently accounted for about 60 percent of total domestic steel production.^{48,72} The main advantage of BOPF steelmaking is that pig iron is converted to steel in about 45 minutes, so labor and certain other costs are lower than in the once prevalent open hearth method.⁷² The main disadvantage of the BOPF process is that the charge must consist of at least 70 percent molten iron.⁷² Therefore, the BOPF must be a part of an integrated steel mill (one which uses iron ore, coke, and limestone to produce molten iron in a blast furnace and subsequently produces steel in a BOPF or other steel furnace).^{72,73} The ability to substitute scrap metal for pig iron in BOPFs is very limited and is dependent on steel market conditions.

The future growth in the BOPF industry is uncertain. Existing BOPF's should remain in use, and existing open hearth furnaces in integrated steel mills will probably be converted to BOPFs if demand is adequate to keep the shops open. However the newer non-integrated and specialty shops typically use electric arc furnaces (EAFs) rather than BOPFs or open hearths.^{48,72}

The BOPF produces steel by blowing oxygen through molten iron. The furnace is a large, open-mouthed vessel lined with a chemically basic refractory material. The furnace is mounted on trunions that allow it to be rotated through 360 degrees in either direction. A typical vessel can have an opening 3.7 to 4.3 m (12 to 14 ft) in diameter and be 6.1 to 9.1 m (20 to 30 ft) high.⁷²

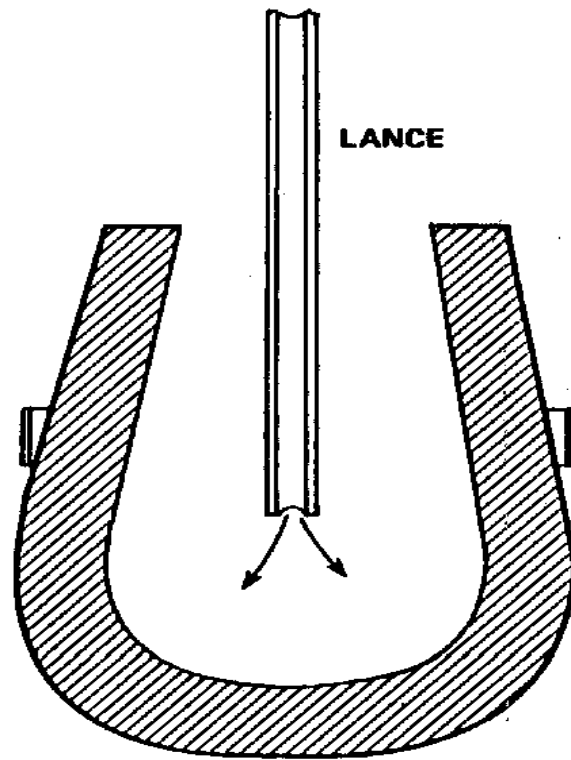

TOP BLOWN

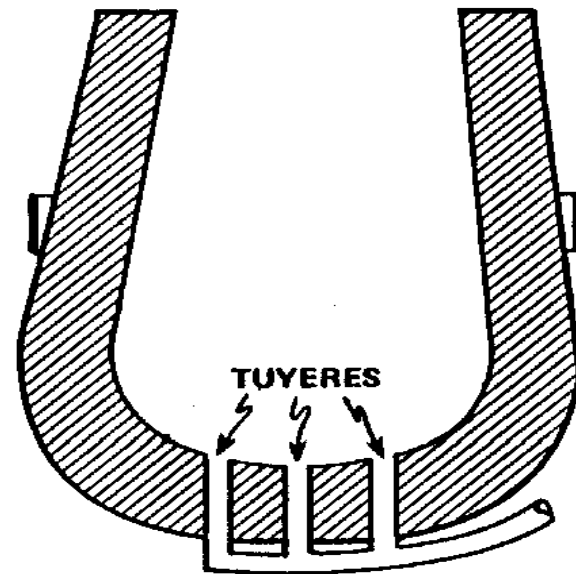

BOTTOM BLOWN

Figure 31. Top blown and bottom blown BOFP vessels. ⁷²

The furnace receives a charge composed of scrap and molten iron which it converts to molten steel. This is accomplished through the introduction of high-purity oxygen that oxidizes the carbon and the silicon in the molten iron, removes these products, and provides heat for melting the scrap. After the oxygen blow is started, lime may be added to the vessel to provide a slag of the desired basicity. Fluorspar may also be added in order to achieve the desired slag fluidity.⁷²

Two distinct types of furnaces are in general use (Figure 31). The most common type is the top blown furnace, in which oxygen is blown into the vessel through a water-cooled lance that can be lowered into the mouth of the upright furnace. The other type of furnace, commonly called a Q-BOP, is bottom blown. In this furnace, oxygen is introduced into the vessel through tuyeres (nozzles) in the furnace bottom.⁷²

The major reason for installing a Q-BOP furnace is that it does not require a great deal of vertical clearance above the furnace enclosure and can therefore fit into existing open hearth buildings. Existing ancillary facilities can be adapted easily for serving Q-BOPs. Other advantages of bottom blown furnaces are slightly increased yields and higher ratios of scrap to hot metal.⁷²

A third type of furnace is currently being used with an increasing frequency in the steel industry. This new form of BOPF is a top blown furnace that has been modified to allow oxygen to be introduced through both the conventional oxygen lance and to be injected through bottom and side tuyeres within the vessel.^{74,75} Because this technology is relatively new, there is not much information available about its utility or about the extent to which it has been applied in BOPF shops.

Steel is produced via the basic oxygen process in distinct operations that occur in the following order:⁷²

1. Charging--The addition of scrap metal or hot metal to the BOPF.
- 2 .Oxygen blow--The refining stage of the process, in which pure oxygen is blown into the BOPF. Lime and flouspar are also added.
3. Turndown--After the blow, the vessel is tilted toward the charging aisle to facilitate taking hot metal samples and making temperature measurements.
4. Reblow--If the samples taken during the turndown indicate the need, oxygen can again be blown into the vessel, usually for only a very brief period.
5. Tapping--Pouring the molten steel out of the BOPF into the teeming ladle. Alloying elements, including chromium, may be added to the ladle.
6. Deslagging--Pouring residual slag out of the BOPF into a slag pot.
7. Teeming--The pouring of molten steel into ingot molds.

These operations are illustrated in Figure 32 and Figure 33. A cross section of a furnace shop is shown in Figure 34.

Emission Factors--

Both process and fugitive emissions are associated with BOPFs. Process (or primary) emissions evolve during the actual steel making or oxygen blowing stage and are generally captured by the primary hood. These emissions consist mainly of iron oxides which result from the reaction between oxygen and molten iron. Particles of slag are also contained in the emissions.⁷² When chromium is a contaminant of the raw materials, chromic oxide will be emitted.

Two types of primary (blowing) emission collection equipment are in common use. One type is an open hood directed to an ESP, similar to that shown in Figure 34. The emissions that evolve during the oxygen blow are captured by the hood and pass through a conditioning chamber where the gas is cooled and humidified to the required levels for proper ESP operation. Electrostatic precipitators can be used

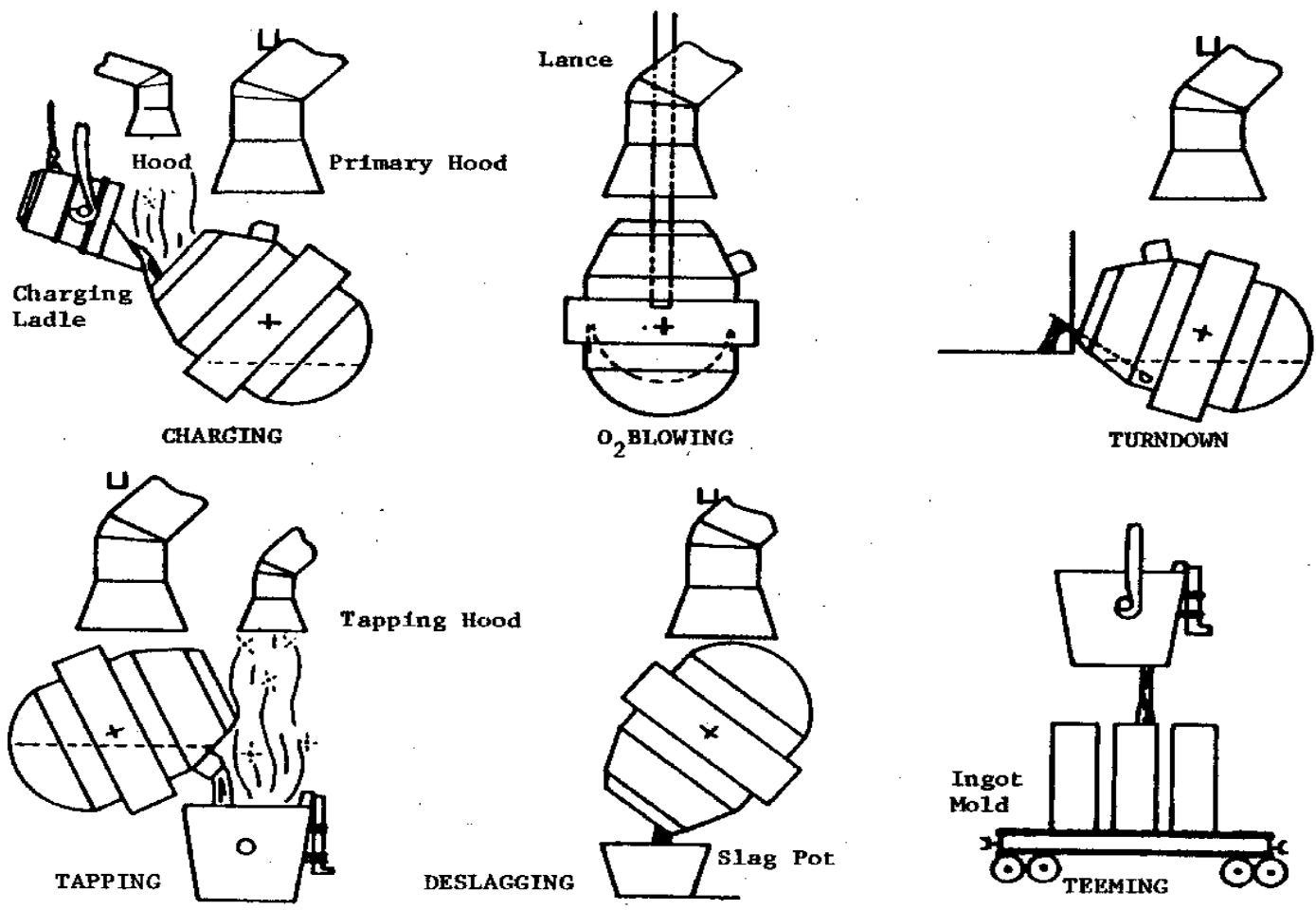

Figure 32. Steps for making steel by the basic oxygen process.

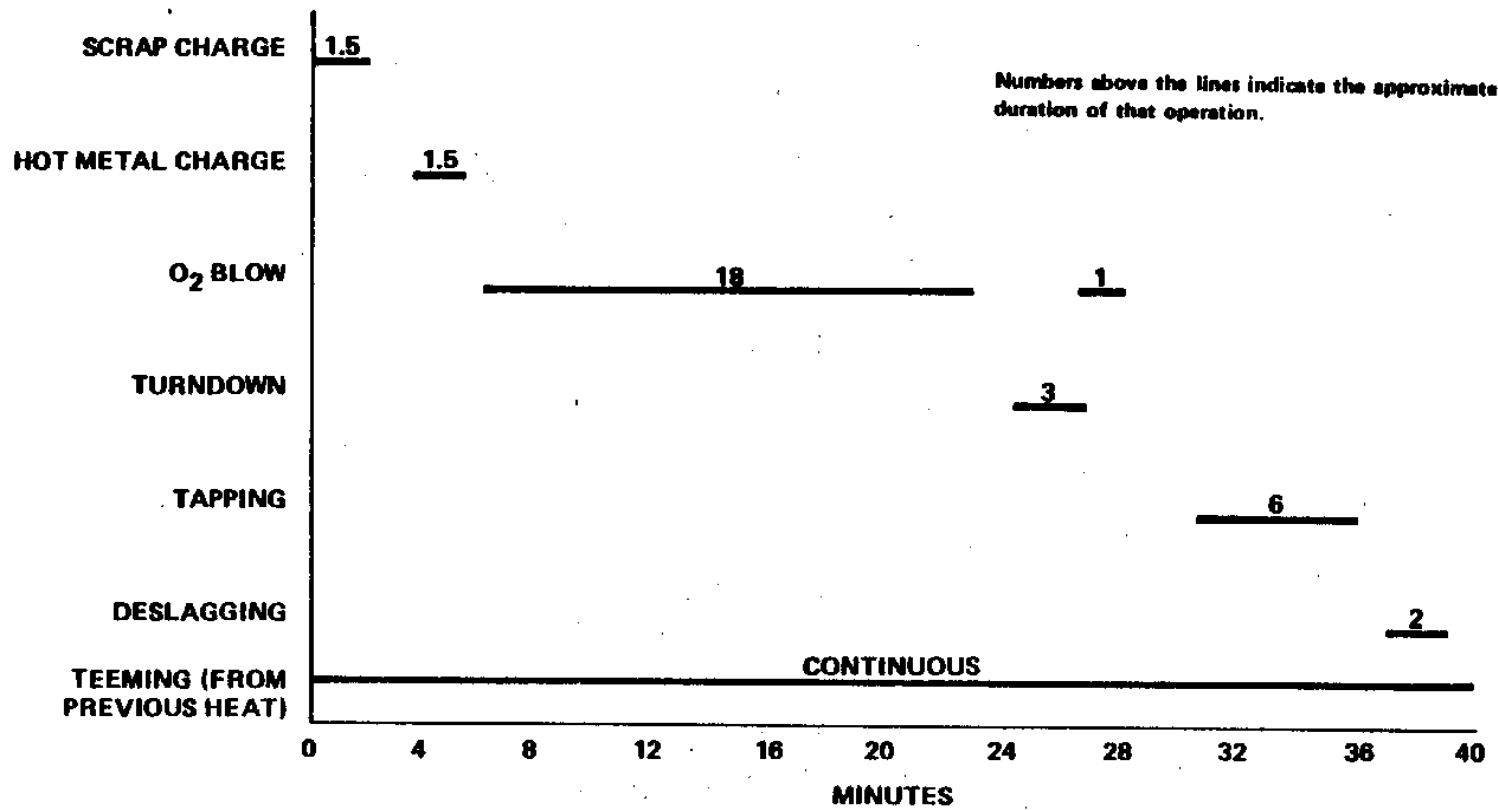

Figure 33. Time sequence of top blown BOPF operations.⁷²

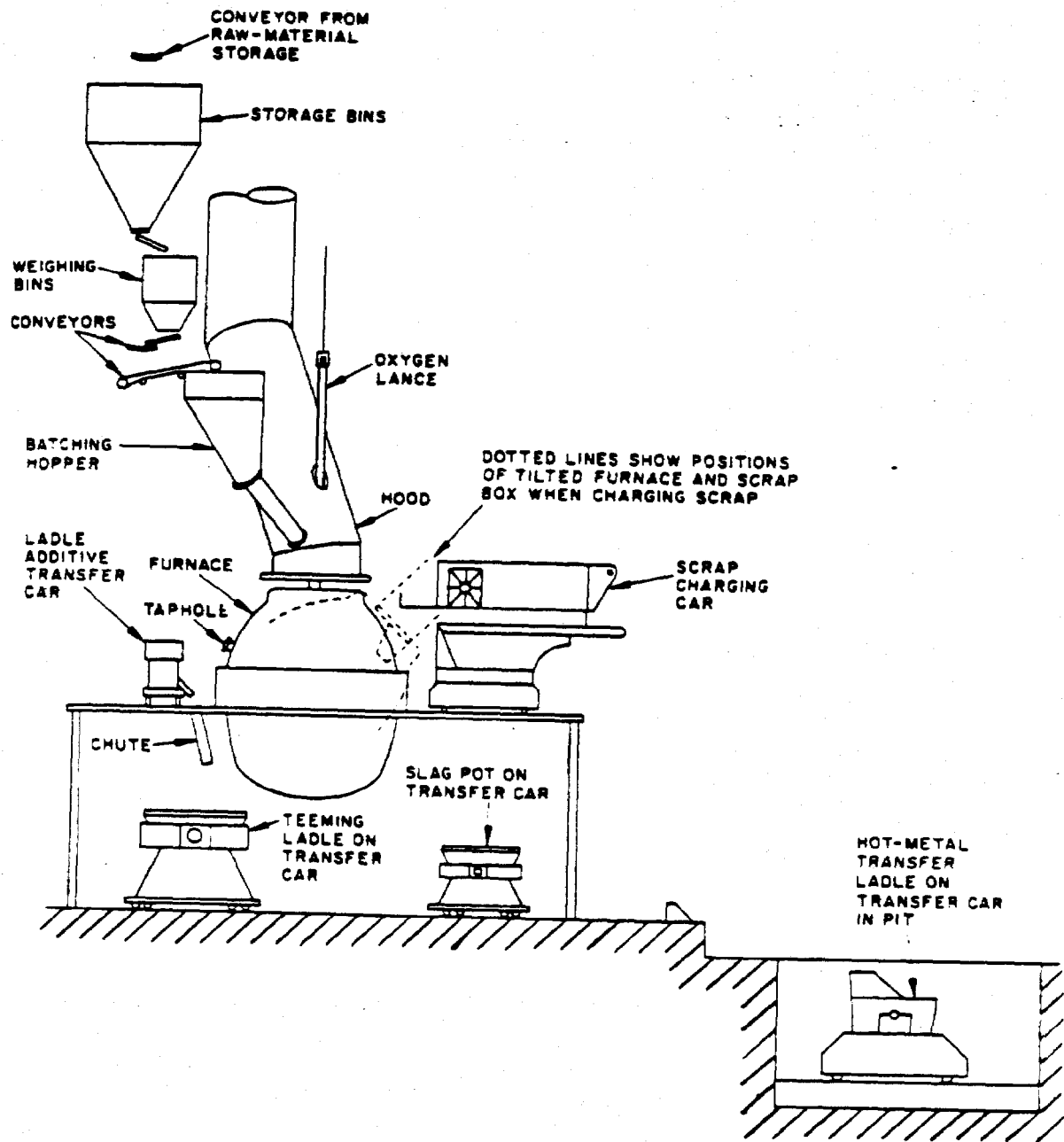

Figure 34. Schematic cross section of a furnace shop. 72

with open hoods because the combustible carbon monoxide (CO) generated during the oxygen blow burns at the mouth of the vessel, reducing the risk of explosions set off by sparks in the precipitator. Alternatives to ESPs are scrubbers or, as has been tried at one plant, fabric filters.⁷² All three alternatives would be effective at chromium removal. Testing at high temperature combustion sources indicates that ESPs are as efficient at removing chromium as they are at removing total particulates.¹³

The other type of primary emission control is the closed hood, in which the diameter of the hood face is roughly the same as the diameter of the mouth of the vessel. The lower portion of the hood is a skirt that can be lowered onto the mouth of the vessel. This seals off the space between the hood and the vessel, limiting the amount of air that can enter the system to about 15 - 20 percent of that entering an open hood system. Because the emissions are rich in carbon monoxide, gas cleaning is performed by a scrubber to minimize the risk of explosion. The cleaned gas is usually flared at the stack.⁷²

Because there is less danger of explosion in the open hood system, all of the vessels in the shop may be connected to a common gas cleaning system. Conversely, the closed hood system must have a separate scrubber system for each vessel because of the potential explosion hazard from leakage of air into the system from an idle furnace.

Fugitive emissions result from a number of sources, and chromium has been detected in these emissions.^{72,76} The major sources are molten iron transfer, charging, tapping, and slag handling. Minor sources include turndown, teeming, ladle maintenance, and flux handling.^{60,77-79} Oxygen blowing process emissions which escape capture by the primary hood may also be considered fugitives. A discussion of the emissions from these sources and typical control technologies follows. The efficiencies of most fugitive collection systems are unknown.

Reladling or hot metal transfer of molten iron from the torpedo car to the charging ladle is accompanied by the emissions of kish, a mixture of fine iron oxide particulates together with larger graphite particles.⁷² Trace amounts of chromium may be present in the pig iron, causing minor chromium emissions from this source. The usual method of control is to provide a close-fitting hood and a fabric filter. A spark box between the hood and the fabric filter protects the filter bags from destruction by large, hot particulates. Normally, the spark box is built integrally with the fabric filter.⁷² Skimming of slag from the ladle of molten iron keeps this source of high sulfur out of the steelmaking process. Skimming is often done under a hood because it results in emissions of kish. This hood is usually connected to a fabric filter.⁷²

Charging of scrap and molten iron into the BOPF vessel results in a dense cloud of emissions. Emissions from the charging of hot metal are particularly severe if the scrap is dirty, oily, otherwise contaminated, or contains such potential sources of explosion as water or ice.⁸⁰ Charging emissions have been shown to contain chromium.⁶ Chromium enters the charge as a contaminant of the scrap. In some open hood shops, if the main hood is large enough and the volume of air flow is sufficient, it is possible to capture most of the charging fumes in the primary collection system of the vessel. In this case, as much of the vessel mouth as possible is kept under the hood and the iron is poured at a slow controlled rate. In other facilities (closed hood primary systems), it is necessary to provide auxiliary hoods in front of the main collection hood. On occasion, a facility may also have a hood at the building monitor to capture any fumes that escape the hoods at the vessel. More charging emissions are produced in bottom blown than in top blown furnaces due to the constant flow of gas through the tuyeres.^{60,72}

Tapping of the molten steel from the BOPF vessel into the ladle results in iron oxide fumes. The quantity of fumes is substantially

increased by additions into the ladle of alloying materials.⁸¹ Chromium may be added as an alloying material,⁷² which would result in chromium emissions from the tapping ladle. Some BOPF facilities enclose the space at the rear of the furnace in such a manner that the fumes are ducted into the main collection system. In other facilities the fumes are permitted to exit through the roof monitors.^{60,72}

Turndown of the vessel for the purpose of taking samples or for pouring out the slag results in emissions. These emissions are particularly copious in the case of the Q-BOP due to the flow of nitrogen through the tuyeres in the bottom of the vessel.⁷² Particulate emissions from turndown may contain chromium which can be a contaminant of the raw materials in the furnace. Some facilities have a pair of sliding doors on the charging floor in front of the vessel. These doors are kept closed as much as possible to direct the fumes into the primary collection system.⁷²

Slag handling may consist of transporting and dumping the ladle of molten slag from the shop to a remote dump area or to an area at the end of the shop. The dumping of slag and its subsequent removal by bulldozer is a dusty operation that is generally uncontrolled.⁷² Chromium may be contained in the slag.

Teeming of steel from the ladle to the ingot mold or continuous caster results in emissions that are normally uncontrolled. Chromium can be emitted from the teeming operation, especially if it was added to the tapping ladle as an alloying material. In some shops where leaded steels are poured, the resultant fumes are extremely hazardous to the health of the workers. In these cases, local hooding is provided.⁷²

The flux handling system is comprised of receiving hoppers for accepting deliveries from trucks or railroad cars, a belt conveyor,

large overhead storage bins, weigh hoppers, feeders, and controls. Hooding is provided at the various transfer points to capture the particulates that escape when the bulk material falls. Exhaust ducts lead from the hoods to one or more fabric filters. Chromium would be only a trace component of the flux.⁷²

Ladle maintenance may be a minor source of chromium emissions, especially if the ladle has been used to produce chromium containing steel alloys. The molten steel that remains in the ladle after teeming may cool and solidify between successive uses forming what are known as skulls. In the vessel, skulls may build up around the lip, and after accumulating for some time, may interfere with proper operation. To prevent this, skulls are burned out with oxygen lances. This lancing procedure results in the emission of iron and other metal oxide fumes. Ladles must also be relined at intervals to protect the steel shell. The ladles are turned upside down to dump loose material onto the shop floor. This generates fugitive dust potentially containing chromium.^{72,81}

Fugitive blowing emissions (puffing emissions) are process emissions that escape capture by both primary and secondary emission control devices. Occasionally, during a blow, chemical reactions within the heat or splashing of the slag will generate large quantities of excess emissions that cannot be handled by the hoods in the furnace enclosure. The frequency or severity of these episodes cannot be predicted or anticipated during the blow.

Chromium emission factors for BOPF furnaces are limited. An analysis of charging emissions at one top blown BOPF revealed an elemental chromium concentration of 0.51 mg/m³.⁷⁶ Process emissions were not analyzed for chromium. Since EAFs rather than BOPFs are used to produce most high chromium stainless and specialty steel alloys, BOPFs would be expected to be a relatively small source of chromium emissions in the iron and steel industry. Trace contamination of the materials would be the main source of chromium in BOPF emissions.

Source Locations--

In 1982, there were approximately 35 steel plants using BOPF furnaces. Typically each plant has two or three furnaces with the exception of four larger plants. The locations of these facilities are given in Table 27.^{72,82,83} The geographic distribution is mapped in Figure 35. The American Iron and Steel Institute's publication, Directory of Iron and Steel Works of the United States and Canada, is the best source of information on BOPF steel manufacturing facilities. The steel industry including BOPFs can also be accessed in standard manufacturing directories and is classified under SIC code 3312.

Open Hearth Furnaces

The open hearth furnace is one type of furnace used to make steel from scrap and pig iron, however, it is being replaced by electric arc furnaces (EAFs) and basic oxygen process furnaces (BOPFs). In 1982 open hearth furnaces accounted for only 8.2 percent of the steel produced in the U.S. (down from 82 percent in 1963).⁴⁸ No new open hearth furnaces are planned and production is expected to continue declining.⁸⁴ The open hearth furnace is not economically competitive with other types of furnaces because of the long time (8 - 12 hrs) it takes to produce a batch of steel. Basic oxygen furnaces take less than 1 hour.⁷³ The open hearth furnace also requires up to twice as many labor hours per unit of steel as the BOPF, and uses 2.5 times more energy than an EAF.⁴⁸

One advantage of open hearth furnaces is that they can run on a charge of 100 percent scrap, 100 percent pig iron, or any combination of the two, depending on availability.⁴⁸ A reverberatory type open hearth furnace is heated alternately by a combustion flame from either end of the hearth. At regular intervals, the gas flow is reversed in order to recover sensible heat from the exhaust gases. This is accomplished by passing them through brick checkers which are at either end of the furnace. At each reversal, the brick checkers are hot enough to heat the incoming combustion air so that the high flame temperatures needed to melt and refine raw materials are more

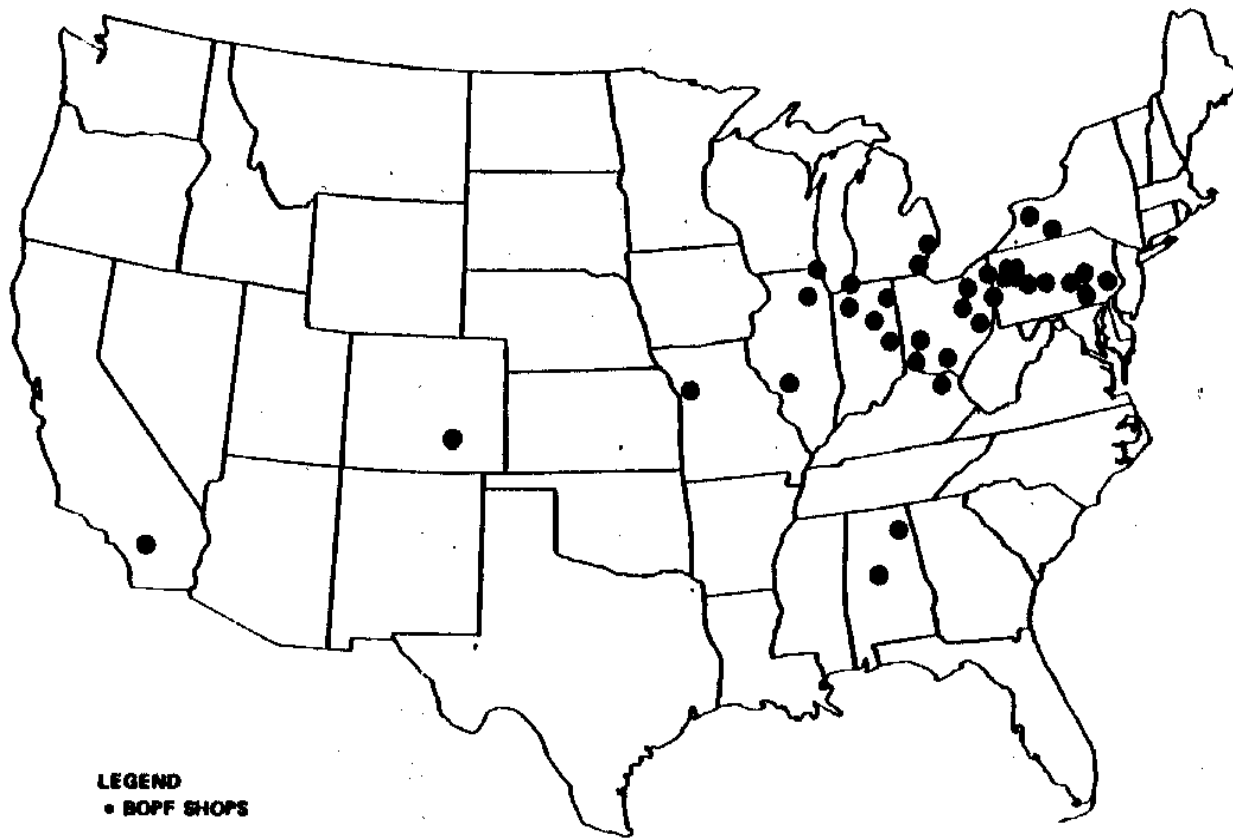

Figure 35. Geographic distribution of the U.S. BOPF steelmaking facilities in 1982.⁷²

TABLE 27. LOCATIONS OF BASIC OXYGEN PROCESS FURNACES (BOPFs) IN
THE IRON AND STEEL INDUSTRY ^{72,82,83}

State and City	Corporation
Alabama	
Fairfield	U. S. Steel Corporation
Gadsden	Republic Steel Corporation
California	
Fontana	Kaiser Steel Corporation
Colorado	
Pueblo	CF&I Steel Corporation
Illinois	
Chicago	Interlake, Inc.
Granite City	National Steel Corporation
South Chicago	Republic Steel Corporation
	U. S. Steel Corporation
Indiana	
Burns Harbor	Bethlehem Steel Company
East Chicago	Inland Steel Company
	Jones and Laughlin Steel Corporation
Gary	U. S. Steel Corporation
Kentucky	
Ashland	Armco Steel Corporation
Maryland	
Sparrows Point	Bethlehem Steel Corporation
Michigan	
Dearborn	Ford Motor Company
Ecorse	National Steel Corporation
Trenton	McLouth Steel Corporation
New York	
Buffalo	Republic Steel Corporation
Lackawanna	Bethlehem Steel Corporation

TABLE 27. LOCATIONS OF BASIC OXYGEN PROCESS FURNACES (BOPFs) IN
THE IRON AND STEEL INDUSTRY ^{72,82,83}

State and City	Corporation
Ohio	
Cleveland	Jones and Laughlin Steel Corporation Republic Steel Corporation
Lorain	U. S. Steel Corporation
Middleton	Armco Steel Corporation
Steubenville	Wheeling-Pittsburgh Steel Corporation
Warren	Republic Steel Corporation Wheeling-Pittsburgh Steel Corporation
Pennsylvania	
Aliquippa	Jones and Laughlin Steel Corporation
Bethlehem	Bethlehem Steel Company
Braddock	U. S. Steel Corporation
Duquesne	U. S. Steel Corporation
Farrell	Sharon Steel Corporation
Midland	Crucible, Incorporated
Monessen	Wheeling-Pittsburgh Steel
Corporation	
Natrona	Alleghany Ludlum Steel Company
West Virginia	
Weirton	National Steel Corporation

Note: This listing is subject to change as market conditions change, facility ownership changes, plants are closed down, etc. The reader should verify the existence of particular facilities by consulting current listings and/or the plants themselves. The level of chromium emissions from any given facility is a function of variables such as capacity, throughput, and control measures. It should be determined through direct contacts with plant personnel.

readily reached. The furnace is charged with scrap and heated to incipient melting by oil, gas, or tar flames which move across the top of the hearth. Hot metal is added to the furnace at this point: The next step involves addition of the necessary flux and oxidizing materials to refine the mix while it boils.⁸⁴ Preheated combustion air, sometimes enriched with pure oxygen, is forced into the furnace to aid the oxidation of impurities.⁴⁸ A slag forms containing the impurities. This is removed by an operation termed slagging. After the molten steel has formed, it is tapped from the furnace.

Emission Factors--

Small chromium-containing particulate matter is emitted from the furnace during steel formation. The amount of oxygen consumed will influence total particulate emissions.⁴ The percent of chromium in the scrap and the type of steel being produced will effect chromium emissions rates. Sources of fugitive emissions from open hearth furnaces include charging, leakage, tapping, and slagging. Charging emissions result from the addition of hot metal or scrap into the hot furnace. Leakage may occur if charging or tapping doors are improperly positioned. Leaks from the oxygen lance-port also occur. Tapping and slagging emissions result from the violent mixing Of the poured molten material.^{60,85}

Emissions from open hearth furnaces are generally controlled with ESPs, although other types of equipment have been used. In 1976, 80 percent of furnaces were controlled with ESPs. Testing of two open hearth furnaces with ESPs showed a total particulate control of 96.6 to 98.8 percent.^{85,86} Chromium collection efficiency was not measured, but other trace metals such as nickel, zinc, copper, lead, and cadmium were removed with about 98 percent efficiency.^{85,86} Venturi scrubbers are also used to control particulate, and therefore chromium, emissions at some open hearth furnaces. Fabric filters, which are typically more efficient particulate (and chromium) removal devices than ESPs, have been installed at a few locations. The disadvantage of fabric filters is that gases must be cooled prior to entering the control device.⁷³

Fugitive emissions from open hearth furnaces are generally controlled by the use of tapping and charging doors or by hooding.⁶⁰ In 1976, about 20 percent of open hearth furnaces were uncontrolled.⁸⁴ The number of uncontrolled facilities has probably decreased since that time as several open hearth furnaces have shut down for reasons previously discussed.

No emission factors are available specifically for chromium. According to the American Iron and Steel Institute, open hearth furnaces are used to produce carbon and non-chromium alloy steel, rather than chromium-containing stainless steel alloys.⁸³ Thus one would expect a relatively low level of chromium in raw materials and particulate emissions.

Source Locations--

A partial listing of open hearth facilities operating as of 1980 is given in Table 28.⁸³ A source of current information on the location of steel manufacturing facilities using open hearth furnaces is the American Iron and Steel Institute's Directory of Iron and Steel Works of the United States and Canada.⁸³ The steel industry, including open hearth furnaces, is classified under SIC code 3312.⁴⁸ Standard manufacturing directories can be consulted for lists of steel producers, although not necessarily the types of furnaces they use.

Leather Tanning

Process Description--

Chromium can potentially be emitted into the air from leather tanning facilities because chromium-based chemicals are used as tanning liquors. Chromium based liquors are used to tan about 95 percent of the hides produced in the United States.⁸⁷

TABLE 28. LOCATIONS OF STEEL PLANTS WITH OPEN HEARTH FURNACES⁸³

State, City	Company
California Fontana	Kaiser Steel Corporation
Indiana East Chicago	Inland Steel Company Jones & Laughlin Steel
Corporation Gary	United States Steel Corporation
Maryland Sparrows Point	Bethlehem Steel Corporation
Ohio Middle ton	Armco, Incorporated
Pennsylvania Fairless Hills	United States Steel Corporation
Homestead	United States Steel Corporation
Johnstown	Bethlehem Steel Corporation
New Castle	Mests Machine Company
Phoenixville	Phoenix Steel Corporation
West Homestead	Mesta Machine Company
Texas Lone Star	Lone Star Steel Company
Utah Geneva	United States Steel Corporation

Note: This listing is subject to change as market conditions change, facility ownership changes, plants are closed down, etc. The reader should verify the existence of particular facilities by consulting current listings and/or the plants themselves. The level of chromium emissions from any given facility is a function of variables such as capacity, throughput, and control measures. It should be determined through direct contacts with plant personnel.

The leather tanning process is illustrated in Figure 36. First, the hides are prepared to receive the tanning agent, a solution predominantly composed of trivalent basic chromium sulfate.⁶⁷ Many tanning facilities buy the chromium sulfate solution made to specification, whereas others buy dry chromium sulfate and formulate their own tanning solutions.^{88,89}

The tanning is accomplished by soaking the hides in the chromium sulfate solution. The purpose of tanning is to stabilize the collagen fibers in the hides so that they are no longer biodegradable. The initial pH of the tanning solution is about 2.8 so that the chromium sulfate is in soluble form. After the solution has penetrated the hides, the pH is gradually raised to 3.4 or 3.6. As this occurs the chromium reacts with the collagen to produce the preserved, tanned hide.⁸⁷

The hides are then stacked overnight to allow further fixing of the chromium. They are then put through a hide wringer until almost dry and sorted. Finishing steps vary depending on the end product, but usually include the application of an oil and water emulsion (fat liquoring), coating with various polymers and dyes, and drying. Drying is accomplished by hanging or laying the hides on plates in a controlled temperature environment or by using a vacuum dryer. If suede is being produced, the leather is buffed, or brushed repeatedly.^{87,88}

Emission Factors--

The two potential sources of chromium emissions from the leather tanning process are the formulation of the chromium sulfate tanning solution and the buffing procedure. At plants which formulate their own tanning solution, chromium sulfate dust containing a trivalent form of chromium is emitted during storage, handling and mixing of the dry chromium sulfate raw material. The formulation process is intermittent and of short duration, which lessens the potential chromium emissions. Furthermore, because the dry chromium sulfate is valuable, care is taken to minimize losses during storage and handling. Little information on specific control technologies is available.

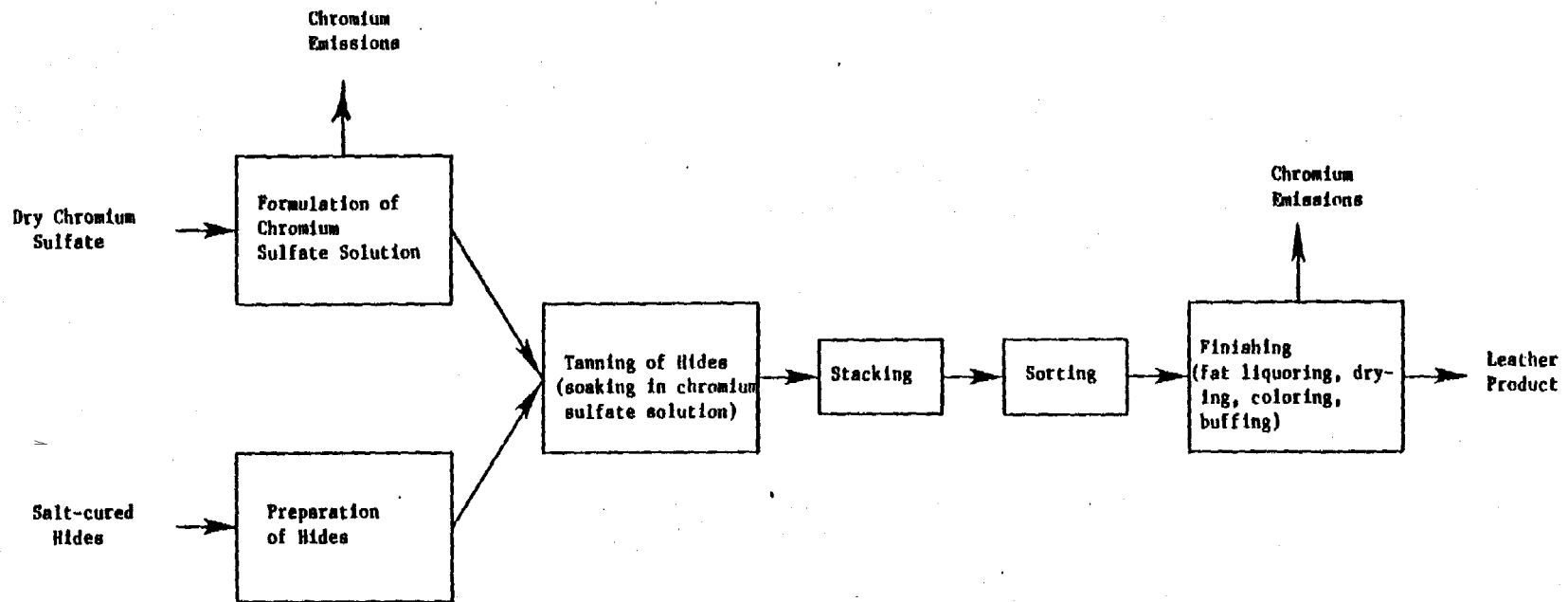

Figure 36. Flow chart for leather tanning process at plants which formulate their own chromium sulfate tanning solution.⁸⁷

There are no atmospheric emissions from the soaking of leather in the tanning solution or from the drying of hides. The methods used for drying would not dislodge particulates or chromium from the leather.⁸⁷

The buffing of tanned hides during the suede finishing process is a possible source of chromium emissions. The repeated brushing, or buffing, of the leather dislodges small particles of leather which contain trivalent chromium. Particulates from this process are contained within the building and are not exhausted to the atmosphere.^{88,90} Buffing operations are intermittent, the extent of which will depend on the demand for suede.

Leather tanning facilities have not been viewed as sources of chromium air emissions by the states in which they are located.^{88,90} Maine conducted ambient monitoring for chromium and found atmospheric chromium levels near tanneries to be the same or slightly less than areas without tanneries.⁹⁰ Although not conclusive, these results indicate that tanneries are not emitting enough chromium to affect ambient chromium levels in surrounding areas. No chromium emission factors for leather tanning operations are available in the literature.

Source Locations--

In 1977, there were about 500 leather tanneries in the United States. Tanneries are located throughout the country, with the greatest concentration in the Northeast. Essex County, Massachusetts has the highest concentration of tanneries in the United States. Table 29 lists some of the larger tanning facilities and their locations.⁹¹ Standard manufacturing directories could be consulted to find the locations of other tanneries using SIC code 3111.

TABLE 29. LARGEST U.S. LEATHER TANNING FACILITIES AND LOCATIONS⁹¹

State, City	Company
Arizona	
Phoenix	Southwest Hide Co.
Illinois	
Chicago	Middleboro Tanning Co. National Rawhide Mfg. Co.
Iowa	
Spencer	Spencer Foods, Inc.
Maine	
East Wilton	Wilton Tanning Co.
Massachusetts	
Beverly	Speco, Inc.
Boston	W. Milender & Sons, Inc.
Danvers	Algy Leather Co., Inc.
Haverhill	Hoyt and Worthen Tanning Corp.
Holbrook	Moran Leather Co.
Peabody	Bob-Hat Leather Co., Inc. Fermon Leather Co., Inc. HDC Leather Co., Inc. N.H. Matz Leather Co. Modern Leather &-Finishing Co. Rex Tanning Corp.
Salem	Hawthorne Tanners, Inc. Mason Tanning Co., Inc.
Tauton	Geilich Tanning Co.
Woburn	Braude Bros. Tanning Corp. Murray Bros. Tanning Co., Inc.
New Jersey	
Newark	A.J. and J.O. Pilar, Inc.
New York	
Brooklyn	Mercury Foam Corp.
Gloversville	Cayadutta Tanning Co. Leather Group Inc. Liberty Dressing Corp.
New York	Eastern Tanning Co., Inc. Walter Hochhauser Leather Co., Inc. Marshall Leather Finishing Co., Inc.

TABLE 29. (CONTINUED) LARGEST U.S. LEATHER TANNING FACILITIES AND LOCATIONS⁹¹

State, City	Company
Oregon Dallas	Muir and McDonald Co.
Pennsylvania Philadelphia	Wm. C. Brown Leather Co.
Texas San Antonio	Nelson and Sons, Inc.
Utah North Salt Lake Vernal	Wills Tannery, Inc. J.G. Drollinger and Associates
Wisconsin Milwaukee	Seidel Tanning Corp. Thiele Tanning Co.
Sheboygan South Milwaukee	Armira Corp. Midwest Tanning Co.

Note: This listing is subject to change as market conditions change, facility ownership changes, plants are closed down, etc. The reader should verify the existence of particular facilities by consulting current listings and/or the plants themselves. The level of chromium emissions from any given facility is a function of variables such as capacity, throughput, and control measures. It should be determined through direct contacts with plant personnel.

INDIRECT SOURCES OF CHROMIUM

Coal and Oil Combustion

Process Description--

Chromium is a trace element common in most coals and oils. Of the many trace elements in coal and oil, chromium is considered to be minor in abundance.⁹² Table 30 and Table 31, respectively, present data that summarize the chromium content of domestic coals by coal type and coal source.^{92,93} Table 32 provides information on the chromium contents of typical oils used in the U. S. Residual oils appear to have higher chromium contents, on the average, than crude oils as a result of the refining process. A heavy metal such as chromium has a very low vapor pressure and exists as a low vapor pressure organo-metallic complex with the higher molecular weight hydrocarbons in crude oil. As such, the metal concentrates in the heavy residual part of the crude as it is distilled.⁹⁸ This concentration phenomena explains why chromium contents of distillate oils are generally lower than residual and crude oils. In analytical tests of several distillate oils by a major oil refiner, chromium was not found at a limit of detection of 0.01 ppm.⁹⁵

The amount of chromium emitted to the atmosphere during coal and oil combustion is dependent primarily on the following factors:

- the chromium content of the fuel,
- the type of boiler used and its firing configuration,
- the partitioning of chromium between fly ash and bottom ash,
- the degree of chromium enrichment on fine fly ash, and
- the chromium removal efficiency of any controls that may be present.

The effect of each of these factors is described in the following paragraphs.

TABLE 30. CHROMIUM CONTENT OF DOMESTIC COALS BY TYPE⁹³

Coal Type	Mean Chromium Content, wt ppm	Standard Deviation, wt ppm	Number of Samples
Bituminous	25.9	2.0	130
North Dakota Lignite	7.5	3.7	10
Texas Lignite	20.4	1.5	29
Anthracite	35.6	7.3	53

TABLE 31. CHROMIUM CONTENT OF DOMESTIC COALS BY SOURCE⁹²

Coal Source	Mean Chromium Content, wt ppm	Standard Deviation, wt ppm	Number of Samples
Eastern U.S. (Appalachia)	20	16	23
Midwestern U.S. (Illinois Basin)	18	9.7	113
Western U.S.	9.0 ^a	4.2	29

^a Data presented in reference 9494 show measured chromium levels in an unwashed and washed western coal to 39 ppm and 43 ppm, respectively.

TABLE 32. CHROMIUM CONTENT OF VARIOUS CRUDE AND FUEL OILS ^{93,95-97}

Oil Type	Average Chromium Content, wt ppm	Range of Chromium Content, wt ppm
Crude Oil	NA ^a	0.0023 - 0.640
Residual No. 6	0.90	0.09 - 1.9
Residual No. 6	NA	0.095 - 0.84
Residual No. 5	NA	0.045 - 6.2
Distillate No. 2	0.048	NA
Distillate No. 2	1.15	0.51 - 2.8
Distillate No. 2	<.01 ppm	NA

^a NA means data not available.

The concentration of chromium in the feed coal or oil has been determined to be the major factor affecting uncontrolled chromium emissions from combustion sources.⁹⁹ The greater the chromium concentration in the fuel, the higher the uncontrolled rate of chromium emissions. For the combustion of coal, the type of boiler and its firing configuration both affect chromium emissions by affecting the amount of coal ash that ends up as bottom ash. The bottom ash contains some concentration of chromium that will not be emitted to the atmosphere. The combustion of oil produces essentially no bottom ash, minimizing the effect of boiler type and firing configuration on the level of chromium emissions from oil fuels.

The emission of chromium from coal or oil combustion is generally explained by the volatilization/condensation mechanism (VCM) theory. The theory basically states that in the firebox of a boiler or furnace peak temperatures of approximately 1650°C (3000°F) volatilize fuel elements such as chromium. The hot flue gases from the combustion process then undergo cooling through convective heat transfer and other mechanisms, condensing the volatilized species. Volatilized chromium may condense or adsorb onto existing particles in the exhaust stream according to the available particulate surface area, or may homogeneously condense into fine chromium-containing particles.¹⁰⁰ Through this procedure, the chromium concentration in the bottom ash is depleted, while the concentration in the fly ash is enriched. This phenomenon occurs because the fly ash has more relative surface area for condensation than the bottom ash and because the bottom ash does not come in contact with the volatilized chromium long enough for it to condense.^{100,101} As an example, in an analysis of three coal-fired utility boilers, chromium was reported to be 23 percent partitioned to the bottom ash and 77 percent to the fly ash.¹⁰²

The degree of partitioning and small particle enrichment that goes on during the volatilization and condensation of chromium has been studied by several researchers, especially for coal combustion. These researchers have devised several classification schemes to describe the partitioning and enrichment behavior of many trace

elements, including chromium. One of the are simplistic, but effective classification systems is given below:^{100,101}

- S Class 1. Elements which are approximately equally distributed between fly ash and bottom ash, showing little or no enrichment onto small particles.
- S Class 2. Elements which are enriched in fly ash relative to bottom ash, or show increasing enrichment with decreasing particle size.
- S Class 3. Elements which are intermediate between Classes 1 and 2.
- S Class 4. Elements which are emitted entirely in the gas phase.

Chromium emissions from coal combustion have been shown to demonstrate the behavior of Classes 1, 2, and 3, and are usually categorized under Class 3. Class 3 elements such as chromium are apparently not totally volatilized during the coal combustion process, and, therefore, exhibit a capability for bottom ash or fly ash deposition. Chromium emissions from oil combustion generally demonstrate the behavior of Class 2 elements, primarily because little bottom ash is present in the combustion system.

Chromium emissions from both coal and oil combustion show preferential enrichment on fine fly ash particles.^{101,103} Because of this enrichment factor, the type of control device used plays an important role in determining how much chromium is removed from the flue gas exhaust. Control devices not designed to remove fine particulates do not perform as well on chromium emissions as devices which are so designed. A summary of the collection efficiencies for chromium that have been determined for ESPs, fabric filters, and wet scrubbers is given in Table 33, Table 34, and Table 35. In addition to control devices, fuel cleaning has also been shown to be an effective method of reducing chromium and other trace element emissions from combustion processes. Physical coal cleaning has been

TABLE 33. CHROMIUM COLLECTION EFFICIENCIES FOR ELECTROSTATIC
PRECIPITATORS ^{104,105}

Source Identification	Fuel	Percent Collection Efficiency
Power Plant A	Coal	99.8
Power Plant B	Coal	98.6
Power Plant C	Coal	99.8
Power Plant D	Coal	98.7
Power Plant E	Coal	97
Power Plant F	Coal	97.6
Power Plant G	Coal	99.2
Power Plant H	Coal	85.6
Power Plant I	Coal	96.2

TABLE 34. CHROMIUM COLLECTION EFFICIENCIES FOR FABRIC FILTERS ^{104,105}

Source Identification	Fuel	Percent Collection Efficiency
Power Plant A	Coal	99.8
Steel Mill		99.9

TABLE 35. CHROMIUM COLLECTION EFFICIENCIES FOR WET SCRUBBERS^{104,105}

Source Identification	Fuel	Percent Collection Efficiency
Power Plant A	Coal	96.1 ^a
Power Plant B	Coal	88.9 ^a
Industrial Boiler A	Coal	95 ^b
Industrial Boiler A	Oil	90 ^b
Power Plant C	Coal	97 ^c

^a Controlled by a venturi scrubber.

^b Scrubber was designed primarily for SO₂ control.

^c The scrubber is preceded by an ESP.

shown to remove from 27 to 65 percent of the chromium in coal depending on the source of the coal. Physical cleaning is 50-65 percent efficient on eastern and midwestern coals, but is only 27 percent efficient on western coals. Oil fuels have successfully been cleaned of trace metals by hydrotreating processes, but no specific removal data for chromium are available. Removal efficiencies of greater than 95 percent have been achieved for nickel which should be a good indicator of potential chromium removal levels because both nickel and chromium exhibit Class 3 enrichment behavior.¹⁰⁴

Emission Factors--

Chromium emission factors for coal and oil combustion are presented in Table 36 and Table 37. In both tables, calculated and measured emission factors are given. For oil combustion, calculated factors have been developed by determining the amount of chromium in the fuel and then by assuming that 100 percent of the chromium is emitted. This approach results in an emission factor that is theoretically the maximum for the fuel under analysis. The only means by which actual emissions could be greater than the calculated value are that chromium is added to the emission stream from metal erosion in the boiler or control device, or chromium is present in combustion air at a significant level. Calculated emission factors for oil combustion are generally much greater than the same factors determined by testing. In one series of tests, calculated chromium emission factors were consistently two times higher than what was determined by actual emissions testing.⁹⁷

Calculated chromium emission factors for coal combustion also rely on the amount of chromium in the fuel as a primary input. The application of average chromium enrichment ratios (which have been estimated by testing) and average control device efficiencies are also an integral part of the calculation. For coal combustion, particularly sources controlled by an ESP, measured chromium emission factors were found to be greater than the amount of chromium that could be calculated to be emitted based on fuel chromium levels. This inconsistency again indicates an influx of chromium into the emission stream.⁹³ Measured chromium emission factors for oil and coal combustion are based on actual emissions generated during source

TABLE 36. CHROMIUM EMISSION FACTORS FOR OIL COMBUSTION^{97,106-111}

Oil Type	Uncontrolled Chromium Emission Factors	Type of Factor
Distillate #2	23.8 - 29 pg/J ^d	Measured
Distillate #2	1.1 - 55 pg/J ^d	Calculated
Distillate #2	0.040 - 0.042 kg/10 ⁶ liters (0.32 - 0.35 lb/10 ⁶ gal)(c,e)	Measured
Residual #4	0.035 kg/10 ⁶ liters (0.29 lb/10 ⁶ gal) ^e	Measured
Residual #5	0.083 kg/10 ⁶ liters (0.69 lb/10 ⁶ gal) ^e	Measured
Residual #6	0.41 kg/10 ⁶ liters (3.4 lb/10 ⁶ gal) ^e	Measured
Residual (No. Unspecified)	28.6 pg/J ^d	Measured
Residual (No. Unspecified)	2.1 - 50 pg/J ^d	Calculated
Residual (No. Unspecified)	5.7. pg/J ^{d,f}	Calculated

^a Chromium emissions from oil combustion are most likely to exist as chromium sulfate, complex oxides of chromium and other metals, and chromium oxide.¹¹³⁻¹¹⁶

^b Calculated emission factors have been developed by determining the chromium content of the oil and making the assumption that all chromium in the fuel is emitted. Measured emission factors have been determined by actual emissions source testing and sample analysis combined with a knowledge of the amount of fuel burned.

^c Reference 9595 indicated the pg/J equivalent of this emission factor would be 1.05 - 1.15 pg/J, assuming that all the chromium present in the emissions came from the fuel. This factor is significantly lower than the other measured values for distillate oil combustion of 23.8 - 29 pg/J. This difference can basically be reconciled by examining the chromium content of the fuels burned. In the case of the lower emission factor, the fuel chromium level was about 0.05 - 0.06 ppmw. The fuel chromium content in the tests that produced the higher value ran 85 high as 2.8 ppmw.

TABLE 36. (CONTINUED)EMISSION FACTORS FOR OIL COMBUSTION^{97,106-111}

^d Emission factor expressed as total chromium emitted per unit of heat energy contained in the fuel.

^e Emission factor expressed as total chromium emitted per mass of oil fired.

^f This emission factor represents controlled emissions. The factor is applicable to control by either wet scrubber or ESP.

TABLE 37. CHRONIC EMISSION FACTORS FOR COAL CONBUSTION ^{94,103,104,106-108,110-112}

Coal Type	Boiler Type	Control Device ^a	Chromium Emission Factors, pg/J ^{b,c}	Type of Factor ^d
Anthracite	Stoker	None	102 - 648	Measured
Anthracite	Stoker	None	200	Calculated
Anthracite	Stoker	MC	16.3	Calculated
Anthracite	Pulverized	ESP	60.2	Calculated
Bituminous	Pulverized	None	1,505 - 2,600	Calculated
Bituminous	Pulverized	None	825	Measured
Bituminous	Pulverized	MC	71.8 - 770	Calculated
Bituminous	Pulverized	MC	5.3	Measured
Bituminous	Pulverized	ESP	45 - 60.2	Calculated
Bituminous	Pulverized	ESP	2.5 - 3,430	Measured
Bituminous	Pulverized	WS	54.2 - 170	Calculated
Bituminous	Pulverized	WS	0.26 - 5.3	Measured
Bituminous	Pulverized	MC/WS	7.8	Measured
Bituminous	Pulverized	FGD	54	Measured
Bituminous	Cyclone	None	495 - 645	Measured
Bituminous	Cyclone	MC	130	Calculated
Bituminous	Cyclone	ESP	8 - 9.3	Calculated
Bituminous	Cyclone	ESP	290 - 2,300	Measured
Bituminous	Cyclone	WS	14	Calculated
Bituminous	Cyclone	WS	46	Measured
Bituminous	Stoker	None	38.3 - 2,000	Calculated
Bituminous	Stoker	None	8.1 - 129	Measured
Bituminous	Stoker	MC	16.3 - 590	Calculated
Bituminous	Stoker	MC	26.8 - 1,040	Measured
Bituminous	Stoker	ESP	58	Measured
Bituminous	Stoker	FE	66	Measured
Lignite	Pulverized	MC	253	Calculated
Lignite	Pulverized	MC	29 - 32	Measured
Lignite	Pulverized	ESP	9.2 - 26.5	Calculated
Lignite	Pulverized	ESP	8.6	Measured

TABLE 37. (CONTINUED) CHRONIC EMISSION FACTORS FOR COAL COMBUSTION ^{94,103,104,106-108,110-112}

Coal Type	Boiler Type	Control Device ^a	Chromium Emission Factors, pg/J ^{b,c}	Type of Factor ^d
Lignite	Pulverized	WS	75	Calculated
Lignite	Cyclone	MC	245 - 430	Calculated
Lignite	Cyclone	ESP	5 - 17.8	Calculated
Lignite	Cyclone	ESP	<3.3	Measured
Lignite	Cyclone	WS	40	Calculated
Lignite	Stoker	MC	16.3	Calculated
Lignite	Stoker	MC	13	Measured
Lignite	Stoker	ESP	<2.3	Measured

^a The key for the control device abbreviations is as follows:

- MC - multicyclones
- ESP - electrostatic precipitator
- WS - wet scrubber
- FF - fabric filter
- FGD - flue gas desulfurization

^b Emission factors expressed as total chromium emitted per unit for heat energy in the fuel.

^c Chromium emissions from coal combustion are most likely to exist as chromium sulfate, complex oxides of chromium and other metals, and chromium oxide.113,114,115,116

^d Calculated emission factors have been developed using average fuel chromium contents, average chromium enrichment ratios, and demonstrated average control device efficiencies. Measured emission factors have been determined by actual emissions source testing and sample analysis combined with a knowledge of the energy content of the fuel burned.

testing and analysis of a boiler and a knowledge of the quantity and characteristics of the fuel burned.

As shown in Table 36 and Table 37, wide variability exists in some of the emission factor estimates for coal and oil combustion. Although it is beyond the scope of this document to reconcile all the reasons for these large ranges, available data suggest that the most important factor influencing the situation is the chromium content of the fuel.¹⁰²

Limited chromium emission factors are also available for the combustion of wood. In one set of tests for five furnaces burning wood, measured chromium emission factors ranged from 0.76 - 11.7 pg/J with the average being 6.4 pg/J.¹⁰⁸ A measured chromium emission factor for wood of 4 pg/J was reported in Reference 111.

Several recent studies have produced results strongly indicating the forms of chromium occurring in emissions from coal and oil combustion. Reference 113113 examined the 100 - 200 μm size fraction of fly ash captured by electrostatic precipitators from coal fired utility boilers. Using magnetic separation and hydrochloric and hydrofluoric acid leaching steps, the fly ash was separated into a glass matrix, a mullite-quartz matrix, and a magnetic spinel matrix of composition $\text{Fe}_{2.3}\text{Al}_{0.7}\text{O}_4$. Analysis by X-ray diffraction and X-ray fluorescence of the separated matrices indicated that approximately 74 percent of the chromium present was associated with the spinel. The theory was put forth that chromium probably existed as a substituted spinel of the form $\text{Fe}_{3-x}\text{Cr}_x\text{O}_4$.¹¹³

Other studies have been performed with results that indicate and support the estimation that a significant part of chromium-containing emissions from coal and oil combustion exist as complex oxides of chromium and other metals.¹¹⁴⁻¹¹⁶ Additionally, the same studies indicated that a large part of the metal-containing emissions from

coal and oil combustion exist as metal sulfates.¹¹⁴⁻¹¹⁶ Together chromium sulfates and complex oxides of chromium and other metals appear to constitute the bulk of chromium emissions from coal and oil combustion.

Source Locations--

Due to the large number of combustion sources in the U. S., individual source listings are not attempted here. However, data on the location of large emitters such as power plants and industrial boilers are available through published government data bases maintained by the U.S. EPA and DOE, the Electric Power Research Institute (ERPI), and the American Boiler Manufacturers Association.

Cement Production

Process Description--

The production of cement is a potential source of chromium emissions because chromium can be a component of both the process feed materials and the fuels such as coal and oil that are burned in cement process kilns and dryers. In 1981 approximately 67.6 million Mg (75.1 million tons) of cement were produced in the U. S. Cement is produced by either a wet or dry method. In the dry method, feed materials are sent to the processing steps in a dry solid form. In the wet method, feed materials are mixed with water and sent to the processing steps as a slurry. Of the total domestic cement production, about 42 percent or 28.4 million Mg (31.2 million tons) is made by the dry method, and 58 percent, or 39.2 million Mg (43.9 million tons), by the wet method.¹¹⁷

The basic process flow diagram for cement production by the wet and dry methods is shown in Figure 37. The raw materials used to make cement can be divided into four basic categories: lime, silica, alumina, and iron. Approximately 1600 kg (3520 lb) of dry raw materials are required to produce 1 Mg (1.1 ton) of cement.¹¹⁸ Following quarrying, raw materials are crushed to a suitable size for processing and are entered into either the wet or dry processing

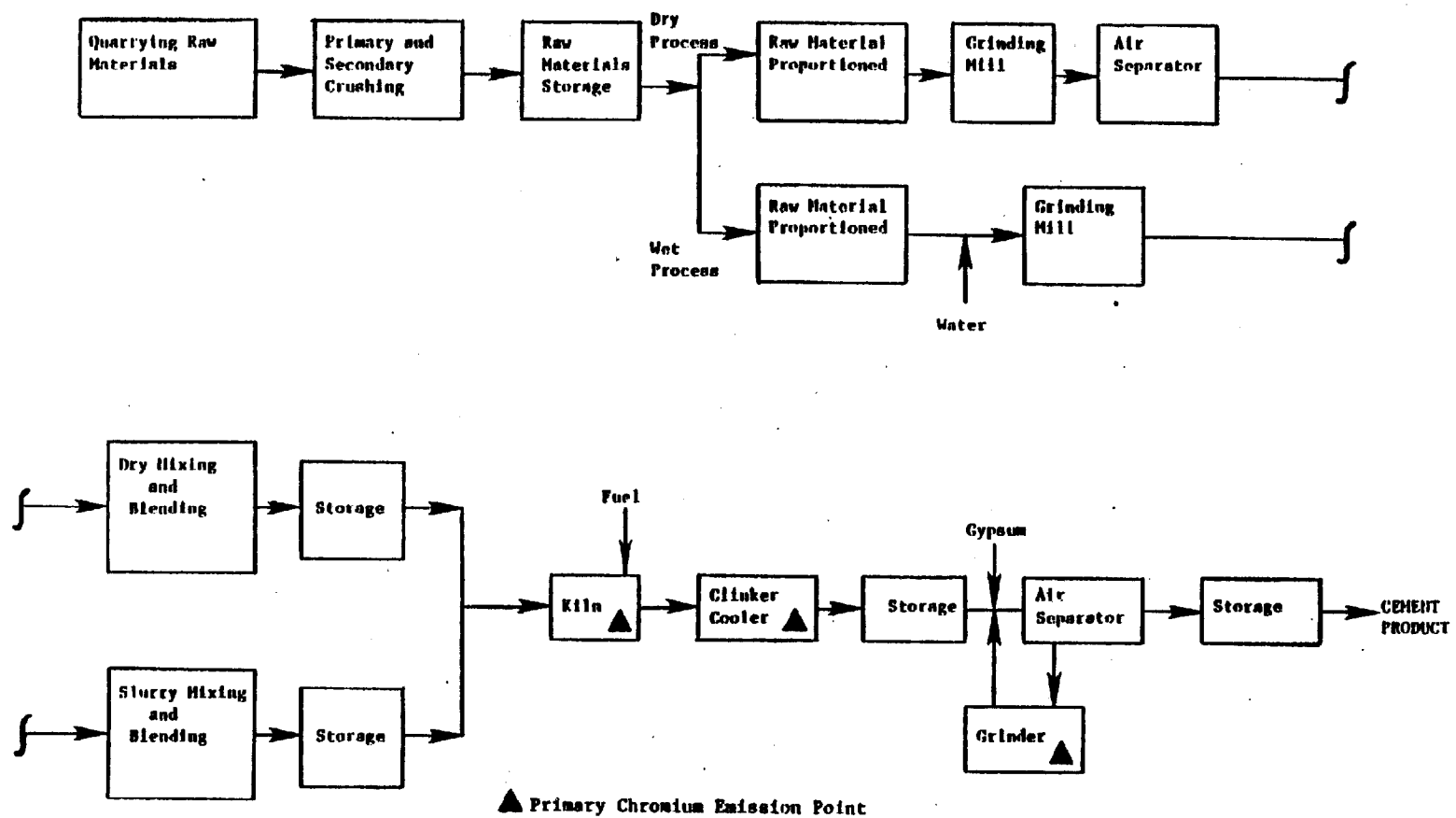

Figure 37. Basic process flow diagram for wet and dry cement production plants. 118

loop. In both wet and dry processes the materials are proportioned, ground, and blended prior to initiating the primary cement production steps.

In the dry process, the moisture content of the raw material is reduced to less than 1 percent either before or during the grinding operation. The dried materials are then ground to a powder, blended, and fed directly-into an inclined rotary kiln. The powdered raw materials are fed into the upper end of the kiln and travel slowly to the lower end. The kilns are fired from the lower end so that hot gases pass upward and through the raw materials. Drying, decarbonating, and calcining are accomplished as the material travels through the heated kiln, finally burning to incipient fusion and forming what is known as clinker. The clinker is then cooled, mixed with about 5 percent gypsum by weight, and ground to a final product size. The cement product is then stored for packaging and shipment.^{118,119}

In the wet process, a slurry is made by adding water to the raw materials at the initial grinding operation. After blending and mixing, excess water is removed and the slurry is adjusted to achieve the proper composition. The homogeneous mixture which is fed to the kilns is usually either a slurry of 30 to 40 percent moisture or a wet filtrate of about 20 percent moisture. The remaining kiln burning, clinker cooling, and gypsum addition steps are carried out the same as in the dry process.^{118,119}

Emission Factors--

The primary chromium emission sources in cement production are the rotary kilns and grinding mills.¹¹⁷⁻¹¹⁹ The majority of the cement industry uses controls such as multicyclones, ESPs, ESPs with cyclones, and fabric filters to reduce particulate, and consequently chromium emissions, from these sources. Typical collection efficiencies for control devices in these applications are:^{117,118}

- multicyclones, 80 percent
- ESPs, 95 percent

- ESPs with cyclones, 97.5 percent
- fabric filters, 99.8 percent.

Few direct measurements of chromium emissions from cement plants have been made. However, total particulate emissions are reported for each stage of the process and the chromium content of the particulate emissions has also been measured. A 1970 study reported that particulate emissions from cement plants contained 0.03 percent chromium, by weight.²⁸ The value of 0.03 percent is the median value determined from tests of several cement plant sources including kilns, dryers, air separators, and clinker coolers. According to a 1979 review conducted for the EPA, kiln dust typically contains 0.011 percent chromium.¹¹⁷

To obtain the chromium emissions factors in Table 38, particulate emission factors from EPA reports^{117,118} were multiplied by 0.011 percent (the percent of chromium in particulate emissions). Factors for Controlled and uncontrolled kilns, grinders, and clinker coolers are listed. The 0.011 percent chromium factor was used to calculate emission factors instead of 0.03 percent because better documentation and support was provided to substantiate the 0.011 percent number.

Few data were found which identified the chromium content of particles from cement processing. Chromium emitted from preliminary crushing and grinding would be in the same form as it is found in raw materials, most likely as a trace constituent of silicate minerals. Chromium emissions from kilns are probably in the forms of oxides of chromium and other metals, chromium oxide, and to a lesser extent chromium sulfate because of the high temperature, oxidizing conditions present in kilns. Chromium emissions from the clinker cooler would be in the same forms as those emitted from the kilns because the chromium particles would not be undergoing any reactions in the cooler. During milling and packaging, chromium would also be emitted in the forms that are produced in the kiln. Chromium emitted from the

TABLE 38. CHROMIUM EMISSIONS FACTORS FOR CEMENT PLANTS ^{117,118}

Emission Source	Control	Chromium Emission Factor ^{a,b} kg/10 ³ Mg (lb/10 ³ tons)	
Dry procescs kiln ^c	Uncontrolled	13	(26)
	ESP	.002-.01	(.004-.03)
	Fabric filter	.001-.01	(.003-.03)
dryers and grinders ^d	Uncontrolled	5	(10)
Wet process kiln	Uncontrolled	12	(25)
	ESP	.002-.02	(.004-.03)
	Fabric filter	.005-.01	(.01-.03)
dryers and grinders ^d	Uncontrolled	1.7	(3.4)
Clinker coolers	Fabric filter	.0006-.007	(.001-.014)
	Gravel bed	.002-.005	(.005-.01)
	Wet scrubber	.002	(.005)

^a Emissions are expressed as total chromium. These emission factors include emissions from fuel combustion, which should not be calculated separately.

^b Emission factors are expressed in terms of the amount of cement produced.

^c Chromium emissions from this source are expected to be in the forms of oxides of chromium and other metals, chromium oxide, and to a lesser extent chromium sulfates.

^d Chromium emissions from this source are expected to predominantly be in the form of chromium silicate minerals.

combustion of fossil fuels and dryers should be in the forms of chromium sulfates, complex oxides of chromium and other metals, and chromium oxide, as discussed previously in the combustion section.

Source Locations--

In 1983 there were approximately 160 cement plants in the United States. The majority of plants were located in California, Texas, Pennsylvania, Michigan, and Missouri.¹²⁰ Individual plant locations can be determined from a variety of sources including:

- cement trade associations (e.g., Portland Cement Association)
- published industrial directories (e.g., Thomas Register, Standard & Poor's)
- the EPA National Emissions Data System (NEDS).

For sources indexed by SIC code, SIC 3241 should be used for cement manufacturing.

Municipal Refuse and Sewage Sludge Incineration

Process Description--

Chromium is released during the incineration of municipal refuse and wastewater sewage treatment sludge because these materials contain varying quantities of chromium. The chromium content of municipal refuse consisting of paper and plastics ranges from 10 - 175 ppm, with an average content being 30 ppm.¹²¹ Dry sewage treatment sludges have chromium contents ranging from 22 - 30,000 ppm, with a mean content of 1,800 ppm and a median of 600 ppm.¹²² The workings of refuse and sewage sludge incinerators and of factors affecting chromium emissions and described below.

The majority of municipal refuse incinerators have either refractory-lined or water-walled combustion chambers that are equipped with a grate upon which refuse is burned. The grate can be stationary, travelling, or vibrating depending on the design of the incinerator. In most cases, natural draft or slight induced draft is

used to pull air up through the grate to carry out the primary refuse combustion process. The combustion gases from the primary chamber pass through a flame port where they are reheated and mixed with air to achieve more complete oxidation. Exhausts from the secondary combustion chamber are either vented directly to the atmosphere or to a control device. The basic configuration of a representative municipal refuse incinerator is given in Figure 38.¹²³

Sewage sludge incineration refers to the oxidation of sludge material generated by wastewater sewage treatment plants. The most prevalent types of incinerators for sludge oxidation are multiple-hearth and fluidized-bed units. Multiple-hearth incinerators are relatively simple pieces of equipment, consisting of a steel shell lined with refractory. The interior of the incinerator is divided by horizontal brick arches into separate compartments or hearths. Alternate hearths are designed with openings to allow solid material to drop onto the hearth below. At the center of the unit, a shaft rotates rabble arms that are located on each hearth. To enable the incinerated material to move inward and then outward on alternate hearths, teeth on the rabble arms are placed at an angle. As sludge is fed through the roof of the incinerator, the rotating rabble arms and rabble teeth push the material across the hearth to drop holes where it falls to the next hearth. This process continues until the sterile ash produced by the oxidation steps is discharged from the bottom of the incinerator. Figure 39 presents a schematic diagram of a typical multiple-hearth sewage sludge incinerator.¹²⁴

The majority of multiple-hearth incinerators have three distinct operating zones. The first zone includes the top hearths where the water-laden sludge feed is partially dried by rising hot combustion gases. The second operating zone is the incineration/deodorization zone where temperatures of 760°- 980°C (1,400 - 1,800°F) are reached and maintained. The third zone of the

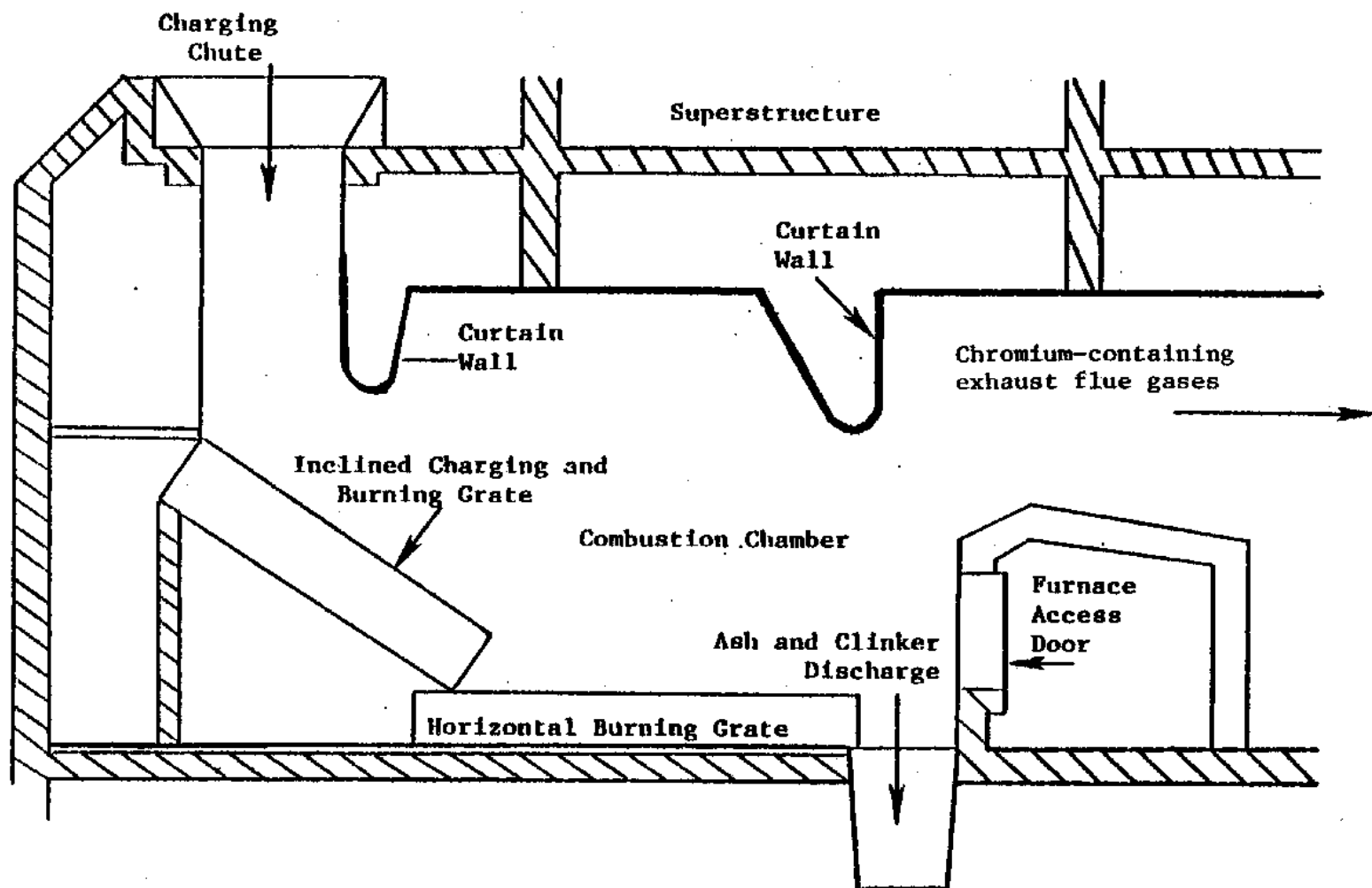

Figure 38. Basic configuration of a municipal refuse incinerator. ¹²³

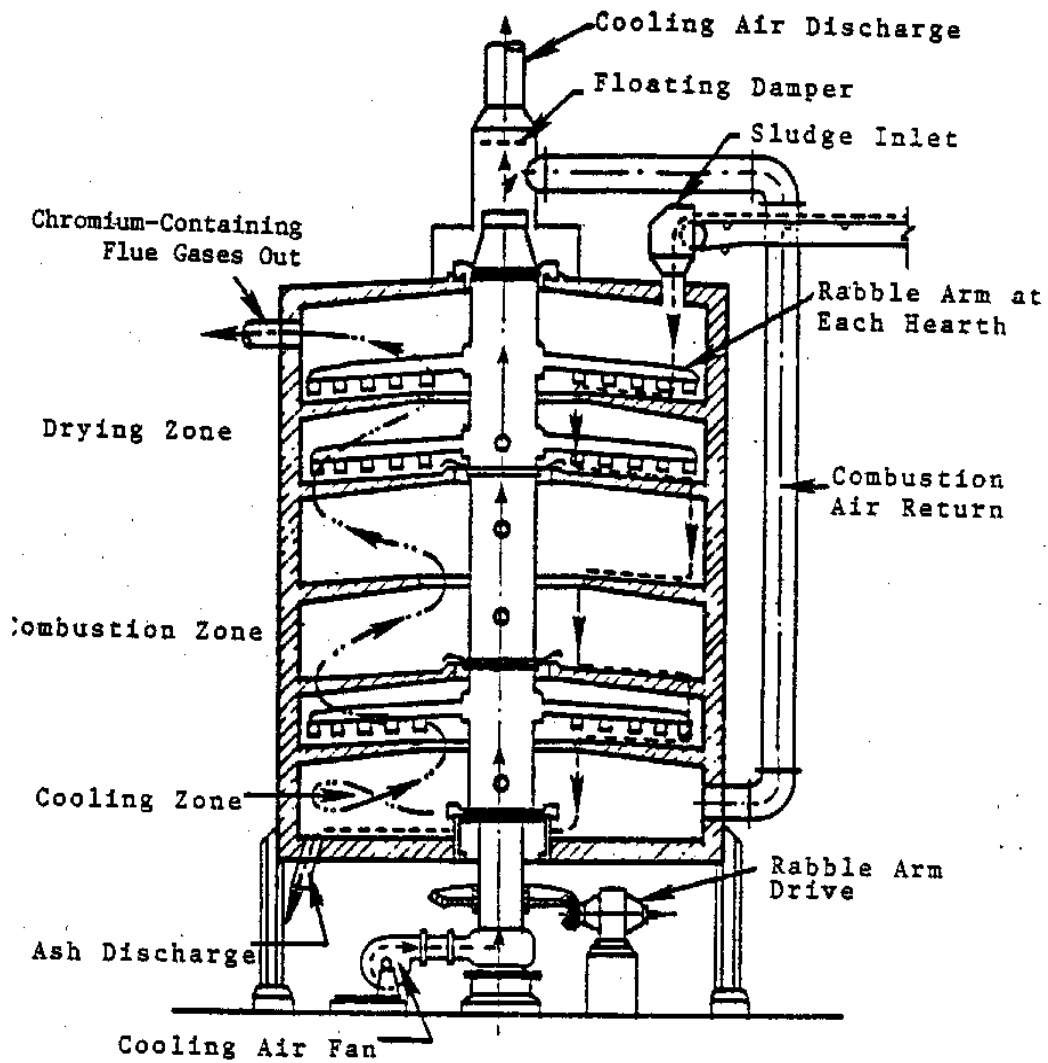

Figure 39. Schematic diagram of a typical multiple-hearth sewage sludge incinerator. 124

multiple-hearth unit is the cooling zone when hot ash from incineration releases heat to incoming combustion air. The design temperature profile of a typical multiple-hearth incinerator is given in Table 39 to illustrate the break in operating zones.¹²⁵

The second technique used to oxidize sewage sludge is fluidized-bed incineration. Figure 40 represents the basic operations found in a fluidized-bed unit.¹²⁵ In this operation dewatered sludge is introduced into the freeboard area of the incinerator just above the fluidized-bed material (which is usually sand). Hot combustion gases rising from the bed evaporate remaining water in the sludge and sludge solids then enter the fluidized bed. The organic constituents of the sludge are oxidized to carbon dioxide and water vapor which exit the system as exhaust gases. During this reaction the bed is vigorously mixed and the bed temperature is maintained at 704 - 816°C (1,300 - 1,500°F). Remaining inorganic sludge material either deposits on the bed sand particles and is removed from the bottom of the reactor, or it can be made to exit with the exhaust gases. Air velocity through the bed is used to control the method of inorganic sludge material removal. Chromium emissions from this type of system are dependent on air flow velocity through the bed and the chromium content of the sludge.¹²⁵

Emission Factors--

The primary factors affecting chromium emissions from municipal refuse incinerators are the chromium content of the refuse and the manner in which combustion air is supplied to the combustion chambers. The manner in which air is supplied can affect the combustion temperature achieved and consequently the level of fly ash emissions.¹²² The types of control devices used to reduce overall incinerator particulate emissions have some effect on reducing chromium emissions. The configuration of controls found in the U. S. varies from simple settling chambers and baffle plates to more sophisticated ESP, wet scrubber, or fabric filter systems. An ESP used to control emissions from a travelling grate refuse incinerator was measured to be 81 percent efficient at removing chromium from the exhaust stream.¹²⁶

TABLE 39. DESIGN TEMPERATURE PROFILE OF A SEWAGE SLUDGE MULTIPLE
HEARTH FURNACE ¹²⁵

Furnace Hearth No. ^a	Nominal Design Capacity, °C (°F)	
1 (Sludge drying zone)	427	(800)
2	649	(1200)
3	900	(1650)
4	788	(1450)
5	649	(1200)
6 (Ash cooling zone)	149	(300)

^a Hearth 1 is at the top of the furnace and 6 is at the bottom.

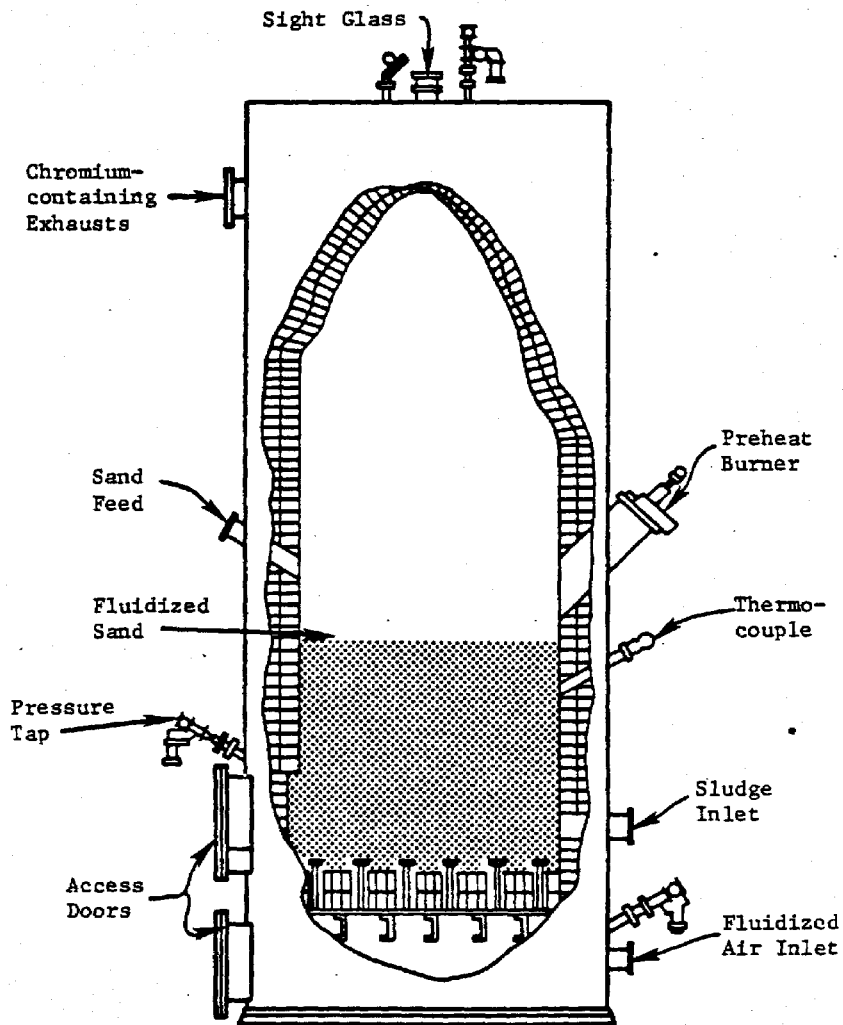

Figure 40. Schematic diagram of a fluidized-bed sewage sludge incinerator. ¹²⁵

Chromium emission factors for chromium from municipal refuse incinerators and sewage sludge incinerators are given in Table 40. These factors are expressed both as a percent of total particulates emitted and as the amount of chromium emitted per ton of refuse incinerated. Chromium emissions at one plant did not change much when sludge was burned with the refuse (see Table 40).

Chromium emissions from sewage sludge incinerators are influenced by the chromium content of the sludge, the combustion temperature of the incinerator, and in the case of fluidized-bed units, the method of inorganic material removal from the bed.^{122,125} Wet scrubbers are extensively used with good success to control multiple-hearth and fluidized-bed sewage sludge incinerators.^{122,125}

The data in Table 40 suggest that the weight percent, of chromium in particulate emissions appears similar for multiple hearth and fluidized-bed incinerators. Those plants emitting higher amounts of fly ash emit more chromium per ton of refuse burned. Results of EPA testing of one fluidized-bed incinerator operated at three temperatures is also shown in Table 40. These data demonstrate clearly that increasing the temperature of a fluidized-bed incinerator significantly increases chromium emissions.

Very few data are available in the literature specifying the species of chromium contained in incinerator emissions. Chromium emissions from refuse and sludge incineration are expected to contain both trivalent and hexavalent forms of chromium. Chromium generally exists in refuse and sludge as trivalent chromium. Upon incineration at high temperature, chromium will be oxidized to hexavalent chromium to some extent. The existence of hexavalent chromium in sewage sludge incinerator emissions has been confirmed.¹³³

TABLE 40. EMISSION FACTORS FOR CHROMIUM FROM MUNICIPAL REFUSE AND SEWAGE SLUDGE INCINERATORS ¹²⁶⁻¹³²

<u>Chromium Emission Factors</u>			
Emission Source		Weight % of Particulates Emitted	kg/Mg (lb/ton) of Solid Waste Incinerated ^a
Municipal Refuse Incinerators			
Multiple Hearth			
Refuse Only ^b		0.10	0.0039 (0.0077) ^f
Refuse and Sludge ^b		0.13	0.0046 (0.0091) ^f
Rocking Grate ^b		0.049	0.0024 (0.0048)
Travelling Grate ^c		0.02	0.0003 (0.0006)
Sewage Sludge Incinerators			
Fluidized-Bed ^b	704°C	0.08	0.00004 (0.00008) ^g
	816°C	0.10	0.00003 (0.00006) ^g
	927°C	0.10	0.0002 (0.0004) ^g
Fluidized-Bed ^b		0.28	0.0003 (0.0006) ^h
Multiple Hearth ^d		0.68	0.0077 (0.014) ⁱ
Multiple Hearth ^e		0.11 ^j	---

^a All factors expressed in terms of total elemental chromium. Chromium is expected to exist in the emissions in both hexavalent and trivalent oxidation states.

^b Source is controlled by a wet scrubber.

^c Source is controlled by an ESP.

^d Emissions from three incinerators were measured. Two were controlled by wet scrubbers and one by a single-pass cyclonic scrubber.

^e Emissions from two incinerators were measured. One was controlled by a water spray baffle and one by an ESP.

^f Emission factor determined from testing of one municipal incinerator by the National Air Pollution Control Administration

^g Emission factor determined by U.S. EPA testing of one sewage sludge incinerator run at three different temperatures.

^h Emission factor determined from U.S. EPA testing of one sewage sludge incinerator.

ⁱ Emission factor determined from U.S. EPA testing of three sewage sludge incinerators. The average is reported.

^j Emission factor determined from testing of fly ash from two sewage sludge incinerators. The same study reported the average chromium concentration on suspended particulates for three incinerators to be 0.05 percent.

Source Locations--

There are approximately 129 municipal refuse incinerators and 141 sewage sludge incinerators in the United States according to recently published U.S. EPA reports and information in EPA's National Emissions Data System (NEDS).¹²⁰ Table 41 lists the distribution of municipal refuse and sewage sludge incinerators in the U. S. by State.

Cooling Towers

Cooling towers can be sources of atmospheric chromium emissions because chromium-containing compounds are sometimes added to cooling tower water as a corrosion inhibiting agent. Corrosion inhibitors are primarily used to protect the heat exchanger and piping in the tower.¹⁴² Although chromium corrosion inhibitors are used in towers of all size applications including electric utilities, industrial plants, and commercial/institutional sites, use is greatest in the industrial sector, particularly in refineries and petrochemical plants.¹⁴²⁻¹⁴⁵ Utilities generally locate near sources of once-through cooling water so towers are not needed or they construct the necessary towers out of corrosion resistant materials. The majority of commercial/institutional towers rely on non-chromium water treatments such as maintenance of high pH or phosphate treatment chemicals.¹⁴²⁻¹⁴⁵

Chromium corrosion inhibitors that are added to cooling tower water contain chromium in the form of chromates or hexavalent chromium. Chromium concentrations in cooling tower water are generally maintained at 15 to 20 wt ppm for corrosion inhibiting purposes.¹⁴⁶⁻¹⁴⁸ Cooling tower chromium emissions occur as a dissolved component of cooling tower drift. Drift is essentially entrained water droplets that have been mechanically formed in the tower and are carried out of the tower by the system air flow. Chromium concentrations in cooling tower drift are approximately equal to the concentrations found in the recirculating cooling water.¹⁴⁶⁻¹⁴⁸ Cooling tower drift and tower chromium emissions primarily are a function of the quantity of heat rejected in a tower, tower air flow, tower design, and ambient meteorological conditions.¹⁴⁶⁻¹⁴⁹ Tower design is

TABLE 41. POPULATION OF MUNICIPAL REFUSE AND SEWAGE SLUDGE
 INCINERATORS IN THE UNITED STATES IN 1983 ^{120,134-141}

State	No. of Municipal Refuse Incinerators	No. of Sewage Sludge Incinerators
Alabama	0	0
Alaska	0	3
Arizona	0	0
Arkansas	29	0
California	0	1
Colorado	0	0
Connecticut	4	5
Delaware	0	0
District of Columbia	1	0
Florida	16	3
Georgia	0	5
Hawaii	1	0
Idaho	0	0
Illinois	1	1
Indiana	1	8
Iowa	0	2
Kansas	0	3
Kentucky	1	7
Louisiana	6	0
Maine	3	0
Maryland	2	0
Massachusetts	5	8
Michigan	0	20
Minnesota	0	10
Mississippi	0	0
Missouri	2	1
Montana	0	0
Nebraska	0	1
Nevada	0	2
New Hampshire	11	4
New Jersey	1	6
New Mexico	0	0
New York	7	5
North Carolina	2	1
North Dakota	0	0
Ohio	1	13
Oklahoma	5	1
Oregon	2	0
Pennsylvania	4	10
Rhode Island	0	2
South Carolina	0	0
South Dakota	0	0
Tennessee	3	3

TABLE 41. (CONTINUED) POPULATION OF MUNICIPAL REFUSE AND SEWAGE
 SLUDGE INCINERATORS IN THE UNITED STATES IN 1983 ^{120,134-141}

State	No. of Municipal Refuse Incinerators	No. of Sewage Sludge Incinerators
Texas	4	4
Utah	0	0
Vermont	0	0
Virginia	7	4
Washington	8	3
West Virginia	0	1
Wisconsin	2	4
Wyoming	0	0
	—	—
TOTAL	129	141

important because most towers are specifically constructed to have a certain fraction of the recirculating water emitted as drift. Baffles and other mechanical obstructions are used to attain a specified drift rate. For cooling towers at utilities that were built prior to 1970, drift losses of from 0.1 to 0.2 percent are common. Newer utility cooling towers have drift losses on the order of 0.002 to 0.005 percent of total recirculating water.¹⁴⁹

The general mechanism of chromium emissions from cooling tower drift is shown in Figure 41. Dissolved chromium is carried out of the tower as a constituent of drift. Because the drift is cooler and denser than the ambient air it will begin to fall to the ground due to the influence of gravity. As the drift falls to the ground, evaporation of the water droplets occurs. At some height, which is dependent on site-specific meteorological conditions, the moisture is evaporated leaving a chromium-containing dust. The form of chromium in the dust is predominantly hexavalent; however, trivalent chromium could be emitted if hexavalent Chromates are reduced in the tower as a result of performing their corrosion inhibiting function.

The deposition of chromium around cooling towers has been demonstrated.¹⁴⁶⁻¹⁴⁸ Test work on several utility cooling towers has confirmed a localized impact on ambient chromium levels. The results of one such test are illustrated in Figure 42.¹⁴⁷ As shown in the figure, ambient chromium concentrations decrease exponentially with distance from the cooling tower. The concentrations in Figure 42 represent the average of 4 days of testing.

Emission Factors--

The only data available on chromium emissions from cooling towers are summarized in Table 42.¹⁴⁹ These data were derived from cooling towers in utility applications. No information is available on chromium emissions from industrial and commercial/institutional size towers.

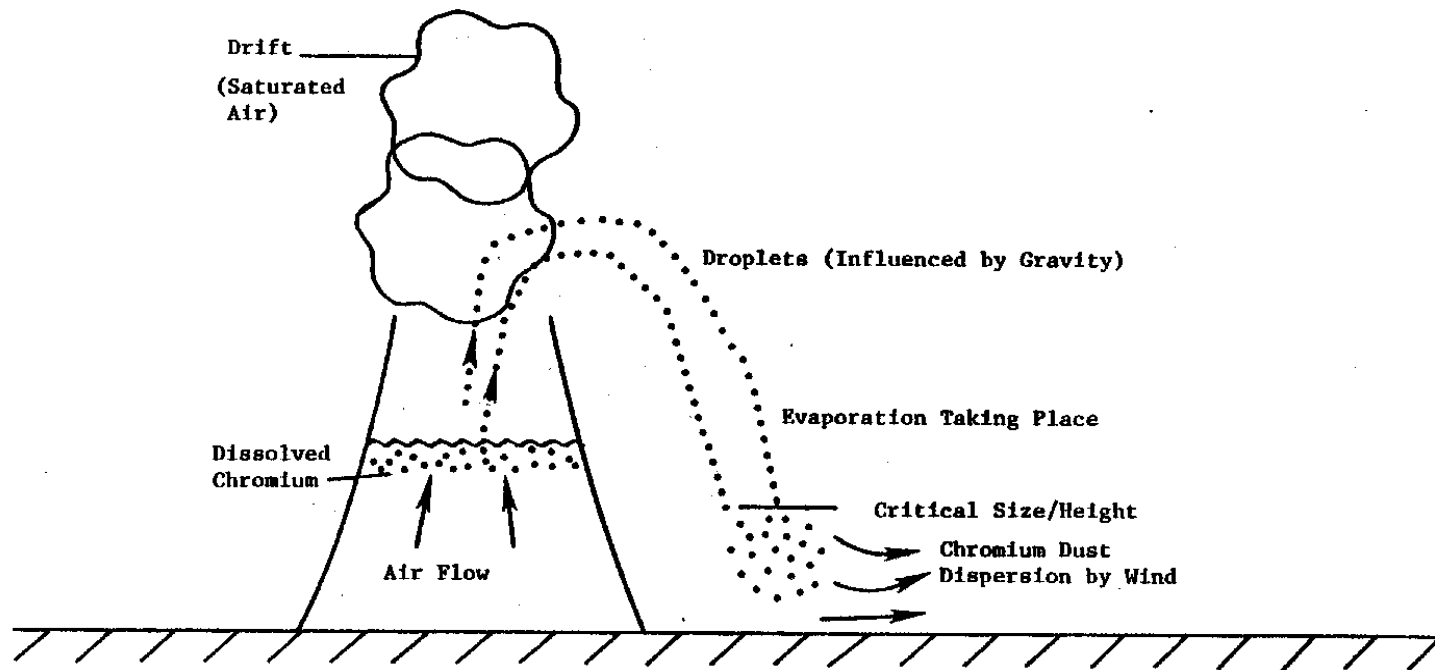

Figure 41. General mechanism of chromium emissions from cooling tower drift.

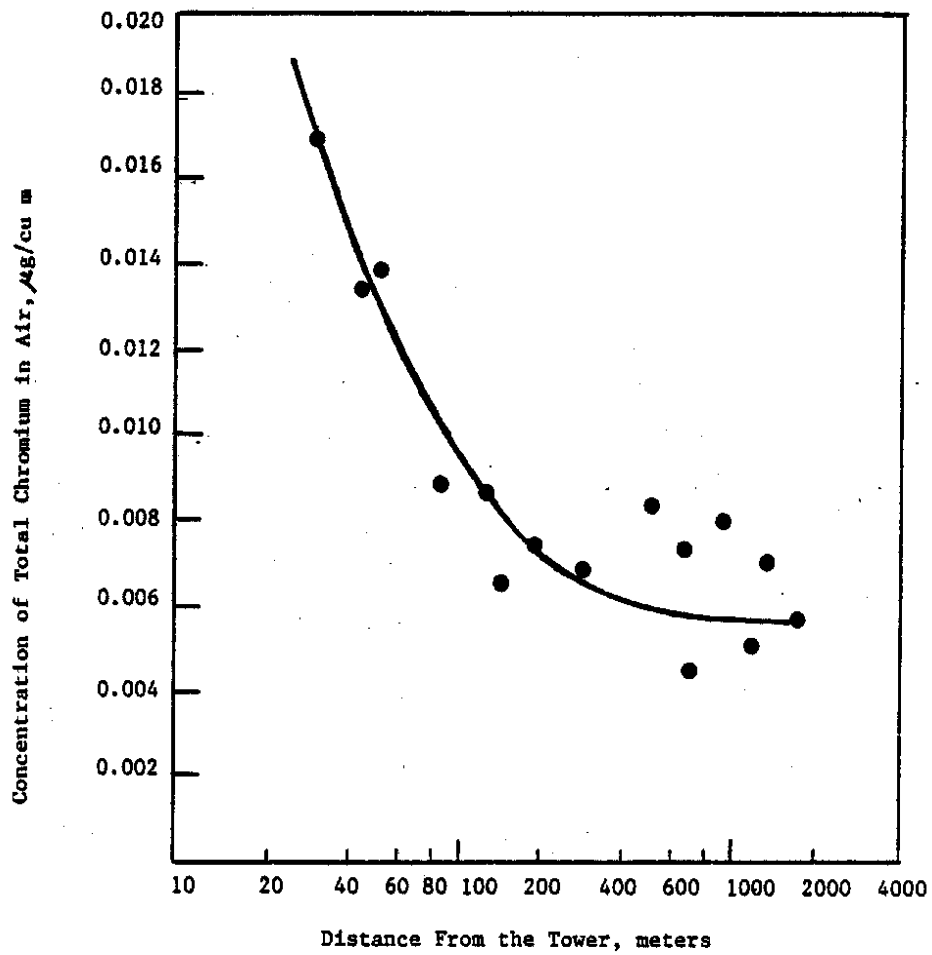

Figure 42. Ambient concentrations of chromium as a function of distance from the cooling tower.¹⁴⁷

TABLE 42. CHROMIUM EMISSION FACTORS FOR FRESH WATER UTILITY COOLING
TOWERS ¹⁴⁹

Chromium Emission Factors, pg/J ^{a,b}	
Drift Loss Range ^c of 0.1 to 0.2%	Drift Loss Range of 0.002 to 0.005%
2.5	0.06

^a Emission factors are expressed as weight of pollutant per thermal energy input to the power plant associated with the cooling tower. Emissions are expressed as total chromium; however, it is likely that emissions will contain chromium in both trivalent and hexavalent oxidation states.

^b Emission factors are based on source tests of three separate cooling towers.

^c Drift loss range refers to the fraction of recirculating water emitted (by design) as drift.

Source Locations--

There are no data available describing the number or distribution of cooling towers in general or of cooling towers using chromium chemical corrosion inhibitors.

Asbestos Mining and Milling

Process Description--

Asbestos is a generic name for a group of naturally occurring, hydrated, mineral silicates. The type of asbestos ore mined in the United States is called chrysotile. For commercial uses, the mined asbestos ore must be separated into fibers and further subdivided into fibrils at a mill. The mining and milling of chrysotile can result in chromium emissions because chromium is a component of chrysotile.^{23,150,151}

There are four asbestos mines in the United States. Underground mining is practiced at one site where ore is deeply buried. At the other sites, where ore lies near the surface, removal is carried out with a bulldozer or by open pit mining. In the latter case, blasting is done before removal to loosen the overburden (materials above the chrysotile) and to reduce ore-containing boulders to a manageable size. Mechanical shovels then load the chrysotile onto trucks for transport to a stockpile at the mill. The material may be wetted during transport and stockpiling to reduce dusting.^{150,151}

The asbestos mill may be situated at the mine site or at a separate location. To prepare the chrysotile ore for milling, it must be crushed in a manner similar to that illustrated in Figure 43.151. The chrysotile ore is fed into a primary jaw-type crusher which accepts boulders up to 122 cm (48 in) in diameter and reduces them to under 5 cm (6 in). Screens are used to separate out materials over 3.2 cm (1-1/4 in) in diameter which then undergo a second crushing in a cone crusher. The outputs of the crushers are then conveyed to a wet stockpile outside the mill.^{150,151}

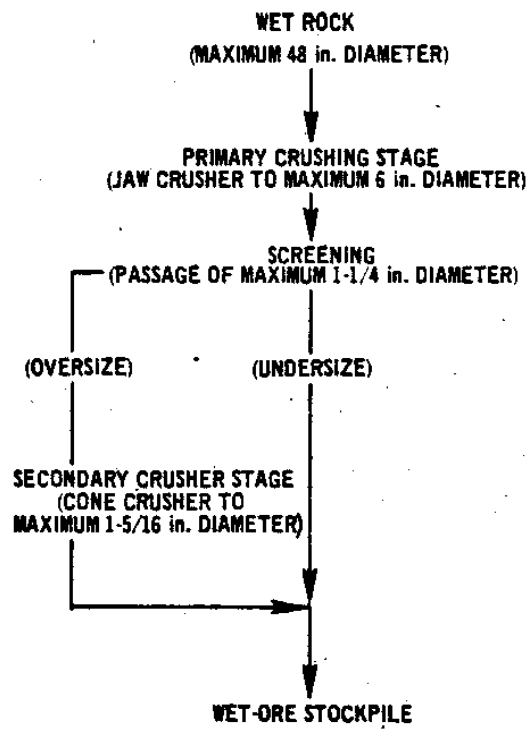

Figure 43. Crushing of massive chrysotile ore. 151

A simplified flow chart of the asbestos milling process is given in Figure 44. There are generally four phases in the milling process: the drying and crushing phase, the rock "circuit," (circuit means subprocess within the overall asbestos milling process), the fiber cleaning circuit, and the grading circuit. To begin the drying and crushing phase, wet ore is removed from the bottom of the stockpile (Figure 44, pt. 1) into an underground tunnel by a vibrating-chute feeder. The wet ore is then fed into a rotating cylindrical dryer (Figure 44, pt. 2). Dry ore is conveyed to a vibrating screen (Figure 44, pt. 3) which sizes the ore for final crushing. Oversized ore is removed from screens and ground in cone crushers, while undersized material bypasses the crushers and is sent to a stockpile. The dried, crushed chrysotile from the cone crushers is also stored in the same stockpile (Figure 44, pt. 5).^{150,151}

The main purpose of the rock circuit (Figure 44, pts. 6-9) is to separate asbestos fibers from rock. The process is initiated by screening the ore with a vibrating screen (Figure 44, pt. 6). Oversized materials pass to fiberizers (Figure 44, pt. 7) which further disintegrate rock to release asbestos fibers. The materials are then routed to shaker screens (Figure 44, pt. 8) equipped with aspirators (air suction hoods). The light asbestos fibers are entrained into the airstream of the aspirators, while the heavier rock is left behind for transport to a tailing dump (Figure 44, pt. 9). The efficiency of recovery of asbestos fibers from chrysotile is between 5 and 50 percent, so a large amount of chromium-containing chrysotile can be present in the tailings.^{150,151}

In the fiber cleaning circuit (Figure 44, pts. 10-13), the asbestos fiber-containing air streams from the aspirators are channeled through cyclone collectors to remove the fibers. These fibers then pass through graders where rotating beater arms break (open up) the bundles of asbestos fibers into smaller units (Figure 44, pt. 11). The asbestos fiber stream then passes through another aspirator and cyclone collector for further cleaning and refinement. Waste materials from the aspirator are recycled to the start of the rock circuit. Asbestos fibers are collected in the cyclones.^{150,151}

Drying and Final Crushing

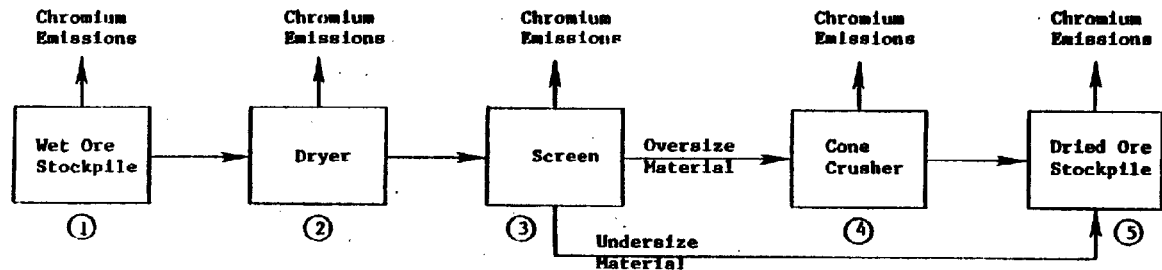

Rock Circuit, Cleaning Circuit, Grading Circuit

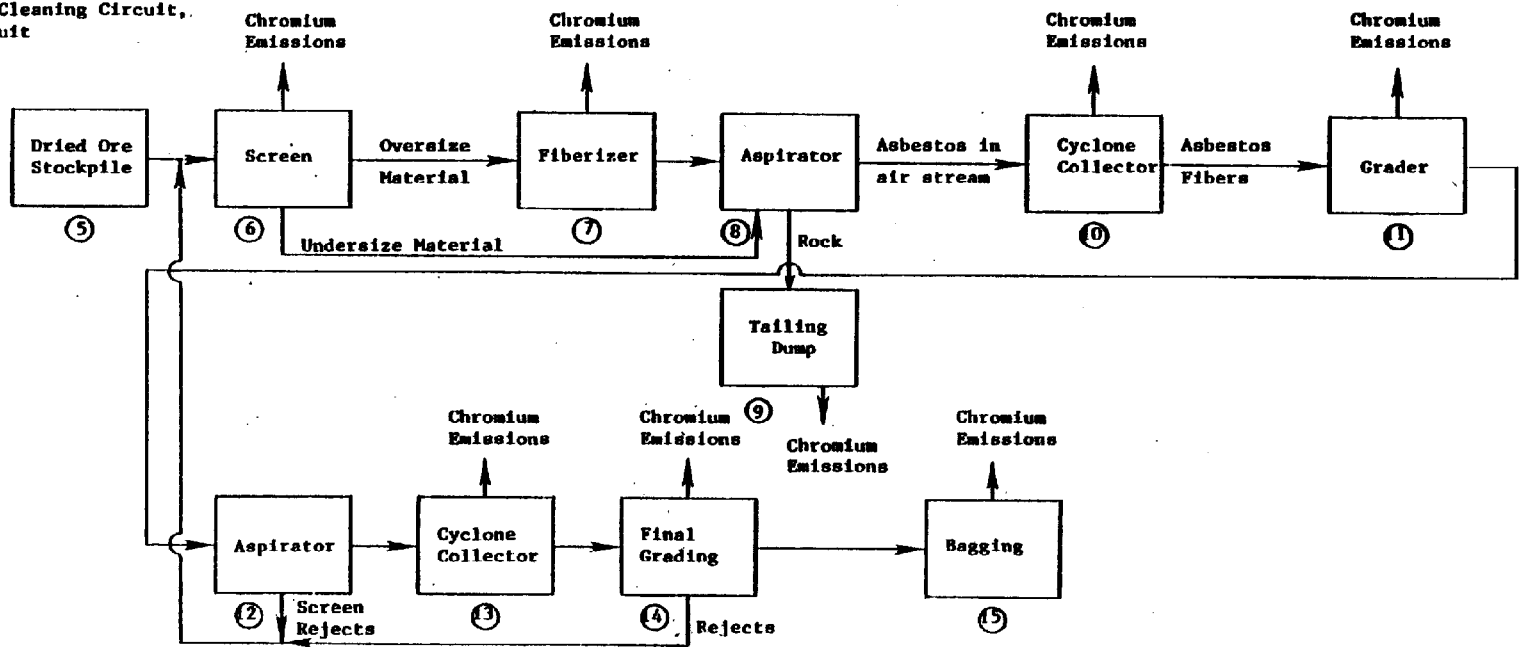

Figure 44. Generalized flow sheet of an asbestos milling process.

Final grading (Figure 44, p. 14) consists of further cleaning and separating of the fibers into standard grades. The asbestos is then packaged by compressing the material into a dense bundle or blowing it into a bag.^{150,151}

Emission Factors--

Potential emission sources of chromium-containing chrysotile during mining include drilling, blasting, bulldozing, loading ore onto trucks, and transporting ore from the mine to the mill. The type of chrysotile mining performed (open pit, surface bulldozing, or underground), weather conditions, chrysotile moisture levels, and the chromium content of the chrysotile ore affect chromium emission rates. Control methods currently being used at mines to reduce particulate emissions are also effective at reducing chromium emissions. Drilling emissions are controlled by using fabric filters to collect drilling rig exhausts and by using wet drilling practices. The latter dust reduction technique cannot be used when temperatures are below freezing. Blasting emissions from chrysotile mining are difficult to control due to their highly fugitive nature. Currently gel blasting agents or water and wetting agents are injected into the holes drilled prior to blasting. Reductions in dust emissions of 20 to 80 percent have been reported using this method. Careful planning and placing of charges can also reduce the amount of blasting necessary.^{150,151}

The overburden removal, surface bulldozing, and ore loading operations are typically uncontrolled sources of chromium-containing particulate emissions. Emissions arising from ore transport are controlled by using covered trucks. Roads around the mine which are surfaced with asbestos mill tailings are periodically wetted to reduce dust emissions, and trucks are required to travel slowly.^{150,151}

Chromium-containing chrysotile particulates are emitted at several points in the primary crushing and milling processes (Figure 43 and Figure 44). Chromium emission sources from the primary crushing of chrysotile ore (Figure 43) include the following:

- unloading ore at the crushing site
- primary crushing
- screening
- secondary crushing
- conveying and unloading ore to the wet ore stockpile

Sources of emissions from the milling process (Figure 44) include:

- wind erosion of wet stockpile surfaces (pt. 1)
- ore dryers (pt. 2)
- screens (pts. 3 and 6)
- crushers (pt. 4)
- dry ore storage (pt. 5)
- fiberizer (pt. 6)
- cyclone collectors (pts. 10 and 13)
- graders (pts. 11 and 14)
- bagging of asbestos (pt. 15)
- wind erosion of the tailing piles (pt. 9)
- conveyors moving asbestos ore, fibers, and tailings between these operations
- conveyor transfer points

Control techniques used to reduce particulate emissions from asbestos crushing and milling also reduce chromium emissions. The primary and secondary crushers and screens (Figure 43) are usually equipped with fabric filters.

Periodic spraying of the wet ore stockpile reduces wind erosion of chromium-containing particulates. Conveyors outside the mill are typically enclosed or their contents are wet.^{150,151}

Crushers, fiberizers, screens, and grading operations in the mill (Figure 44) are usually contained under negative pressure, and dust-containing air is exhausted through a fabric filter. Cyclone and dryer exhausts containing chromium are also vented through fabric filters. Ventilation systems at the asbestos bagging stations channel chromium-containing asbestos dust through fabric filters. Measured efficiency of fabric filters at one U.S. asbestos plant was over 99.9 percent.¹⁵⁰

Large quantities of mill tailings are generated each year which contain waste rock and unrecovered asbestos ore. Points where tailings are deposited from conveyors onto the tailing piles are either hooded and the dust exhausted through fabric filters, or tailings are sprayed with water as they are deposited. Chemicals may be added to the water to help bind particles together and thereby reduce emissions upon drying. In time, natural wetting and freezing may help consolidate dust into larger particles and reduce wind erosion. Attempts to vegetate tailing piles have not been very successful because the high alkalinity inhibits plant growth.¹⁵⁰

No factors are available in the literature specifically for chromium emissions from asbestos mining and milling. However, total particulate emissions have been estimated and measured, and chromium emission factors can be calculated from these data. The chromium emission factors-shown on Table 43 were calculated from estimates of total annual particulate emissions, from U. S. mines and mills in 1969,150 divided by total domestic asbestos production.¹⁵¹ These particulate emission factors were multiplied by 0.15 percent, which is the typical weight percent of chromium in chrysotile. Resulting factors are expressed as pounds of chromium emitted per ton of asbestos produced.

More recent information was used to compute the value of .000008 kg/Mg (.000015 lb/ton) for milling listed on the last line of Table 43. This factor was based on a mill producing 36,300Mg (39,930 tons)

TABLE 43. CHROMIUM EMISSION FACTORS FOR ASBESTOS MINING AND MILLING

Source	Chromium Emission Factors kg/Mg (lb/ton) of Asbestos Produced ^a	
Mining and Milling ^b	.07	(.14)
Mining		
Uncontrolled	.008	(.015)
50% Controlled	.004	(.008)
80% Controlled	.002	(.003)
Milling		
Uncontrolled	.08	(.15)
80% Controlled	.02	(.03)
99% Controlled	.0008	(.0015)
Milling		
Controlled	.000008	(.000015)

^a Factors reported as total elemental chromium. Chromium is emitted in the form of the chrysotile silicate mineral; however, the oxidation state of chromium is unknown.

^b Degree of control unspecified. The proportion of chromium emissions from mining versus milling is also unspecified.

tons) of asbestos/yr and an asbestos particulate emission rate of 180 kg (396 lb/yr).^{152,153} To calculate the chromium emission factor, it was again assumed that emissions contained 0.15 percent chromium. This factor is probably more representative of current control technology id chromium emission rates than the higher rates shown in Table 43.

Source Locations--

In 1981, there were four asbestos mines and four asbestos mills in the United States. The locations of these are shown in Table 44.¹⁵⁰

Coke Ovens

Process Description--

The production of metallurgical coke is a potential source of chromium emissions because of chromium in the coal being processed. Coke production involves the destructive distillation of coal by heating it in a low oxygen atmosphere, driving off gases generated by the decomposition of organic compounds in the coal. After distillation only the relatively involatile coke remains. The primary method of coking in the U. S. is the byproduct method, which accounts for 98 percent of domestic production.¹⁵⁴

The byproduct method is designed to recover gases-generated during the coking process. A coke battery comprises a series of 40 to 70 narrow rectangular, slot-type coking ovens interspersed with heating flues. Figure 45 illustrates the arrangement of a typical coke oven battery. Coal is charged into ports on the top of the ovens by a device called a larry car. After charging, the ports are sealed, and heat is supplied to the ovens by the combustion of gases passing through the flues between ovens. The fuels used in the combustion process are natural gas, coke oven gas, or gas from an adjacent blast furnace. Inside the ovens, coke is first formed near the exterior walls and then the process progresses toward the oven center, where temperatures of 1,150°C (2,100°F) can be reached. The complete coking process takes 16 to 20 hours. Once the process is complete,

TABLE 44. LOCATIONS OF ASBESTOS MINES AND MILLS IN 1981¹⁵⁰

City and State	Corporation
Mines	
Gila County, AZ	Jaquays Mining Corp.
Copperopolis, CA	Calaveras Asbestos Corp.
Santa Rita, CA	Union Carbide Corp.
Orleans County, VT	Vermont Asbestos Group
Mills	
Globe, AZ	Jaquays Mining Corp.
Copperopolis, CA	Calaveras Asbestos Corp.
King City, CA	Union Carbide Corp.
Orleans County, VT	Vermont Asbestos Group

Note: This listing is subject to change as market conditions change, facility ownership changes, plants are closed down, etc. The reader should verify the existence of particular facilities by consulting current listings and/or the plants themselves. The level of chromium emissions from any given facility is a function of variables such as capacity, throughput, and control measures. It should be determined through direct, contacts with plant personnel.

Potential Chromium
Emissions Sources

- ① Pushing emissions
- ② Charging emissions
- ③ Door emissions
- ④ Topside emissions
- ⑤ Battery underfire emissions

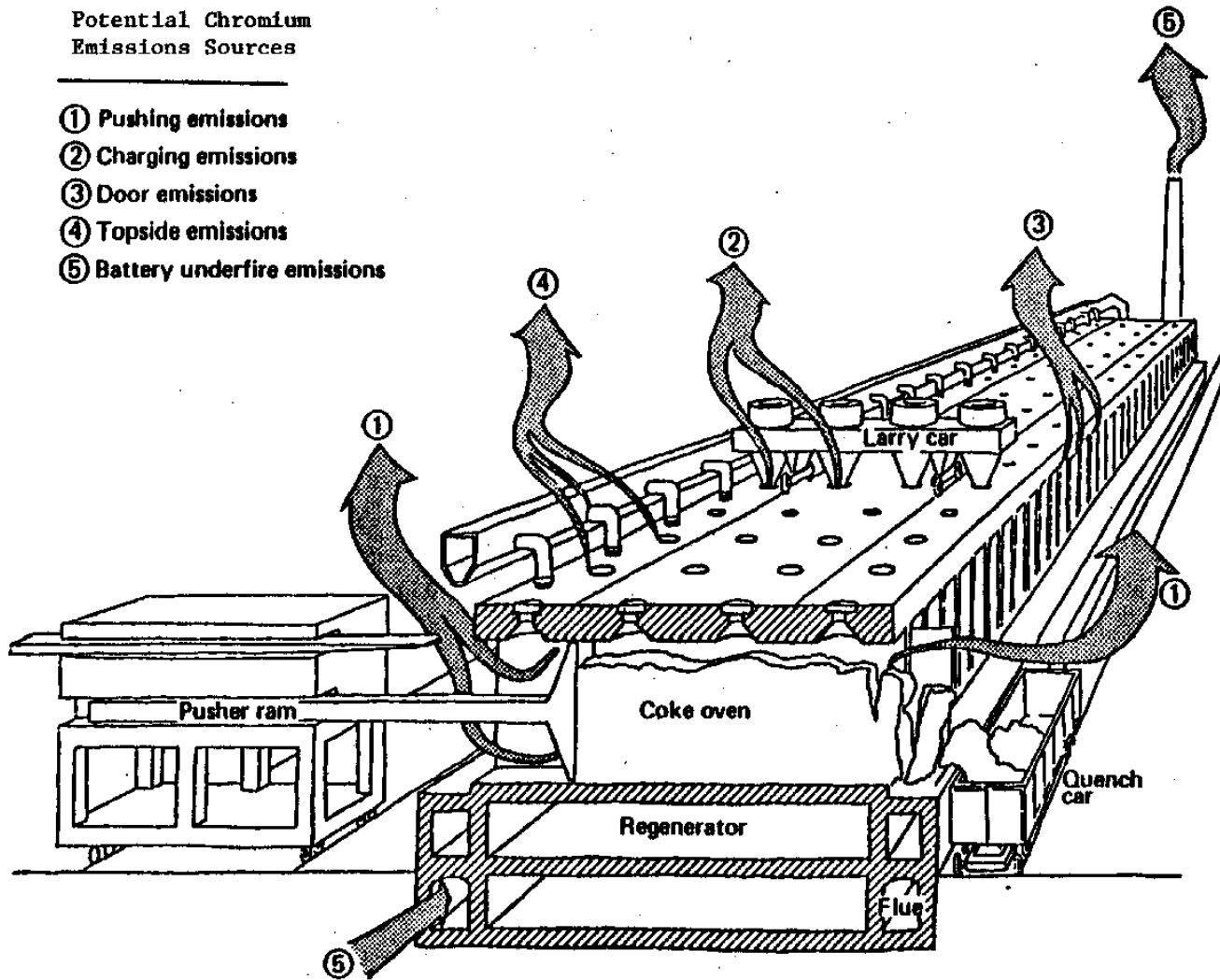

Figure 45. Metallurgical coke oven battery. 142

complete, coke is removed from the oven simply by pushing it out with a ram into a quenching car. The quenching car full of extremely hot coke is moved into the quench tower and cooled by applying several thousand gallons of water. The coke is then allowed to dry before being separated into various size fractions for future uses.¹⁵⁴

Emission Factors--

The possible process related chromium emission points from a coke oven battery are indicated in Figure 45. Chromium emissions may also be generated during quenching operations and from materials handling operations involving coal unloading, crushing, and sizing.¹⁵⁴ The form of chromium emissions from these coking sources has not been determined and expressed in the literature.

No emission factors for chromium from metallurgical coke production are available from the literature.

Source Locations--

Table 45 presents the complete listing of coke production plants in the United States as of January 1980.¹⁵⁵

TABLE 45. COKE PLANTS IN THE UNITED STATES AS OF JANUARY 1980 ¹⁵⁵

Company Name	Plant Location
Armco, Inc.	Hamilton, OH
	Houston, TX
	Middletown, OH (2)
Bethlehem Steel Corp.	Bethlehem, PA
	Burns Harbor, IN
	Johnstown, PA
	Lackawanna, NY
	Sparrows Point, MD
CF&I Steel Corp.	Pueblo, CO
Crucible Steel, Inc.	Midland, PA
Cyclops Corp. (Empire-Detroit)	Portsmouth, OH
Ford Motor Co.	Dearborn, MI
Inland Steel Co.	E. Chicago, IN (3)
Interlake, Inc.	Chicago, IL
J&L Steel Corp.	Aliquippa, PA
	Campbell, OH
	E. Chicago, IN
	Pittsburgh, PA
	Fontana, CA
Kaiser Steel Corp.	Fontana, CA
Lone Star Steel Co.	Lone Star, TX
National Steel Corp.	Granite City, IL
	Detroit, MI
	Weirtofl, WV
	Brown's Island, WV
	Cleveland, OH (2)
Republic Steel Corp.	Gadsden, AL
	Massillon, OH
	S. Chicago, IL
	Thomas, AL
	Warren, OH
	Youngstown, OH

TABLE 45. (CONTINUED) COKE PLANTS IN THE UNITED STATES AS
OF JANUARY 1980 ¹⁵⁵

Company Name	Plant Location
U. S. Steel Corp.	Clairton, PA (3) Fairfield, AL Fairless Hills, PA Gary, IN Lorain, OR Provo, UT
Wheeling-Pittsburgh	E. Steubenville, WV Monessen, PA
Alabama By-Products Corp.	Tarrant, AL
Allied Chemical Corp.	Ashland, KY
Carondelet Coke Company	St. Louis, MO
Chattanooga Coke and Chemical Comp.	Chattanooga, TN
Citizens Gas and Coke Utility	Indianapolis, IN
Detroit Coke	Detroit, MI
Donner-Hanna Coke Corp.	Buffalo, NY
Empire Coke Comp.	Holt, NY
Erie Coke and Chemicals	Painesville, OH
Indiana Gas and Chemical	Terre Haute, IN
Zronton Coke Corp. (McLouth Steel)	Ironton, OH
Keystone Coke Comp.	Swedeland, PA
Jim Walter	Birmingham, AL
Koppers Co., Inc.	Erie, PA Toledo, OH Woodward, AL
Milwaukee Solvay	Milwaukee, WI
Philadelphia Coke (Eastern Assoc. Coal Corp.)	Philadelphia, PA

TABLE 45. (CONTINUED) COKE PLANTS IN THE UNITED STATES AS
OF JANUARY 1980 ¹⁵⁵

Company Name	Plant Location
Shenango, Inc.	Neville Island, PA
Tonawanda Coke Co.	Buffalo, NY

^a Numbers in parentheses indicate the number of plants at that location. If no number is indicated, only one plant exists at that location.

NOTE: This listing is subject to change as market conditions change, facility ownership changes, plants are closed down, etc. The reader should verify the existence of particular facilities by consulting current listings and/or the plants themselves. The level of nickel emissions from any given facility is a function of variables such as capacity, throughput, and control measures, and should be determined through direct contacts with plant personnel.

REFERENCES FOR SECTION 4

1. Morning, J.L. et al. Chromium. In: Mineral Facts and Problems, 1980 Edition. U. S. Bureau of Mines, Washington, DC. pp. 1-16.
2. Telephone conversation between Brooks, G., Radian Corporation and Papp, J., U. S. Bureau of Mines. Chromite Ore Refining. January 27, 1983.
3. State of Delaware Division of Environmental Control, Wilmington Office. Permit number APC-81/969-Operation. Permit issued to C-E Minerals, Inc. for Two Chrome Sand Rotary Dryers at Pigeon Point Rd., New Castle, Delaware. September 18, 1981. 5 pages.
4. State of Delaware Division of Environmental Control, Wilmington Office. Permit number APC-81/967-Operation. Permit issued to C-E Minerals, Inc. for one Hardinge Mill at Pigeon Point Rd., New Castle, Delaware. September 18, 1981. 8 pages.
5. State of Delaware Division of Environmental Control, Wilmington Office. Permit number APE-82/179-Operation. Permit issued to C-E Minerals, Inc. for Bin Vent at Pigeon Point Rd., New Castle, Delaware. October 21, 1981. 4 pages.
6. Towill, L. E. et al. Reviews of the Environmental Effects of Pollutants: III. Chromium. EPA-600/1-78-023. U. S. Environmental Protection Agency, Cincinnati, Ohio, May 1978. p. 203.
7. Background Information for Standards of Performance: Electric Submerged Arc Furnaces for Production of Ferroalloys. Volume 1: Proposed Standards. EPA 450/2-74-018a. The U. S. Environmental Protection Agency, Research Triangle Park, NC. October 1974.
8. A Review of Standards of Performance for New Stationary Sources - Ferroalloy Production Facilities. EPA 450/3-80-041. The U. S. Environmental Protection Agency, Research Triangle Park, NC. December 1980.
9. Dealy, J. O. and A. M. Killin. Engineering and Cost Study of the Ferroalloy Industry. EPA 450/2-74-008. The U. S. Environmental Protection Agency, Research Triangle Park, NC. May 1974.
10. Telecon. Brooks, G. W., Radian Corporation with Watson, G., Ferroalloy Association. February 23, 1983. Chromium Emissions from Ferroalloy Production.
11. Katari, V. et al. Trace Pollutant Emissions from the Processing of Metallic Ores. EPA 650/2-74-115. The U. S. Environmental Protection Agency, Research Triangle Park, NC. October 1974.

12. National Emissions Data System. Maintained by the Monitoring and Data Analysis Division of the U. S. Environmental Protection Agency, Research Triangle Park, NC. 1983.
13. Baig, S. et al. Conventional Combustion Environmental Assessment Final Report. Draft. Prepared for U. S. Environmental Protection Agency, Research Triangle Park, NC. Contract #68-02-3138. July 1981.
14. Kirk-Othmer Encyclopedia of Chemical Technology. Third Edition. Volume 6. John Wiley. and Sons, Inc. New York, 1980. pp. 54-82.
15. Background Information for Standards of Performance: Electric-Arc Furnaces for Production of Ferroalloys Volume 2: Test Data Summary. EPA 450/2-74-018b. The U. S. Environmental Protection Agency, Research Triangle Park, NC October 1974.
16. Source Category Survey: Refractory Industry. EPA 450/3-80-006. Prepared for the U. S. Environmental Protection Agency, Research Triangle Park, NC. March 1980.
17. The Refractories Institute. Refractories. The Refractories Institute, Pittsburgh, Pennsylvania. 1979.
18. Letter from Olenn, S. F., the Refractories Institute to Lahre, T. F., U. S. EPA. February 27, 1984. Comments on draft chromium report.
19. Joiner, R. L. et. al. Evaluation of the Potential Health Effects of Trivalent Chromium Compounds in the Refractory Industry. Prepared by Battelle Columbus Laboratories, Columbus Ohio for The Refractories Institute. February 1983.
20. Papp, J. F. Chromium. In Bureau of Mines and Minerals Yearbook, Volume I. U. S. Department of the Interior, Washington, DC. 1981.
21. Letter and attachments from Cherill, J. L., Corhart Refractories to Beard, II, C. G., West Virginia Air Pollution Control Commission. June 9, 1976. Manufacturing Process Particulate Operations Registration. 16 pages.
22. Havighorst, C. R. and S. L. Swift. The Manufacture of Basic Refractories. Chemical Engineering. Volume 72, pages 98100:August 16, 1965.
23. GCA Corporation. National Emissions Inventory of Sources and Emissions of Chromium. EPA-450/3-74-012. Prepared for the U. S. Environmental Protection Agency, Research Triangle Park, NC. May 1973.

24. Letter from McHugh, G. D., General Refractories Company to Behling, M., Utah Division of Environmental Health. August 20, 1982. 1981 Emission Inventory Forms. 12 pages.
25. Mikami, H. M. Refractory Chromites from South Africa and Other Non-Misinloc Sources. Presented at the Conference for Raw Materials for Refractories. U. S. Department of the Interior, Bureau of Mines, Tuscaloosa, Alabama. February 1982.
26. Product Directory of the Refractories Institute of the United States. The Refractories Institute, Pittsburgh, Pennsylvania. May 1982.
27. Kirk-Othmer Encyclopedia of Chemical Technology. Third Edition. Volume 6. John Wiley. and Sons, Inc. New York, 1980. pp. 54-120.
28. Towill, L. E. et al. Reviews of the Environmental Effects of Pollutants: III. Chromium. EPA-600/1-78-023. U. S. Environmental Protection Agency, Cincinnati, Ohio, May 1978. pp. 208-210.
29. Foley, Jr., E. F. Chromium Chemicals Manufacture. In: Proceedings of the Symposium on Health Aspects of Chromium Containing Materials, Baltimore, Maryland, September 15, 1977. Industrial Health Foundation. 1978.
30. North Carolina Environmental Management Commission, Raleigh, North Carolina. Application for a Permit to Construct and Operate Air Pollution Abatement Facilities and/or Emission Sources. Filed by John A. Licata, Diamond Shamrock Corporation, Castle Hayne, North Carolina. September 5, 1979. 27 pages.
31. Letter and attachments from Diamond Shamrock Corporation, Castle Hayne, North Carolina Chromium Chemicals Plant to North Carolina Environmental Management Commission, Raleigh, North Carolina. July 24, 1979. Summary of Project Expected for Plant. p. 1 of attachments.
32. North Carolina Environmental Management Commission, Raleigh, North Carolina. Application for a Permit to Construct and Operate Air Pollution Abatement Facilities and/or Emission Sources. Filed by S. G. Lant, Diamond Shamrock Corporation, Castle Rayne, North Carolina. February 8, 1978. 12 pages.
33. North Carolina Environmental Management Commission, Raleigh, North Carolina. Application for a Permit to Construct and Operate Air Pollution Abatement Facilities and/or Emission Sources. Filed by Diamond Shamrock Corporation, Castle Hayne, North Carolina. August 30, 1982. 6 pages.
34. Letter and attachments from Steve Langevin, Radian Corporation Office in Austin, Texas to Garry Brooks, Radian Corporation Office in Durham, North Carolina. March 21, 1983. RE: American Chrome and Chemicals. 6 pages.

35. North Carolina Board of water and Air Resources, Raleigh, North Carolina. Application for a Permit to Construct and Operate Air Pollution Abatement Facilities and/or Emission Sources. Filed by Diamond Shamrock Corporation, Castle Hayne, North Carolina. January 1976. 6 pages.
36. North Carolina Environmental Management Commission, Raleigh, North Carolina. Application for a Permit to Construct and Operate Air Pollution Abatement Facilities and/or Emission Sources. Filed by Diamond Shamrock Corporation. Castle Hayne, North Carolina. January 1976. 17 pages.
37. North Carolina Environmental Management Commission, Raleigh, North Carolina. Application for a Permit to Construct and Operate Air Pollution Abatement Facilities and/or Emission Sources. Filed by Diamond Shamrock Corporation. Castle Hayne, North Carolina. January 1976. 20 pages.
38. Chemical Marketing Reporter. Volume 221, Number 22. May 31, 1982. p. 50.
39. SRI International. 1982 Directory of Chemical Producers, United States of America. SRI International, Menlo Park, California. 1982.
40. Sittig, M. (Noyes Data Corporation). Environmental Sources and Emissions Handbook. Noyes Data Corporation, Park Ridge, New Jersey. 1975. pp. 263-270.
41. Kirk-Othmer Encyclopedia of Chemical Technology. Third Edition. Volume 6. John Wiley. and Sons, Inc. New York, 1980. pp. 65 - 66.
42. Kirk-Othmer Encyclopedia of Chemical Technology. Third Edition. Volume 8. John Wiley and Sons, Inc. - New York. 1980. pp. 826-844.
43. Daley, P.S. Pollutant Generation by Air Force Electroplating Processes. CEEDO-TR-77-10. Civil and Environmental Engineering Development Office, U. S. Air Force, Tyndall Air Force Base, Florida. June 1977.
44. Gothard, N. Chromic Acid Mist Filtration. Pollution Engineering, Volume 10, Number 8, pp. 36- 37. August 1978.
45. Diamond, P. Air Pollution Potential From Electroplating Operations. Environmental Health Laboratory, McClellan Air Force Base, California. Report Number 69M-15. April 1969.
46. The Thomas Register of American Manufacturers and Thomas Register Catalog File. 73rd Edition. Thomas Publishing Company. New York, New York. 1983. pp. 11038 - 11074.

47. Papp, J. F. Chromium. Preparing from the 1982 Bureau of Mines Minerals Yearbook. U. S. Bureau of Mines, Washington, D.C. 1983.
48. Electric Arc Furnaces and Argon-Oxygen Decarburization Vessels - EPA-450/3-82-020a. Background Information for Proposed Revisions to Standards. The U. S. Environmental Protection Agency, Research Triangle Park, NC. July 1983.
49. Technology Leads the Way as Electric Furnace Steel making Heads for New Heights in the U. S. 33 Metal Producing. Volume 18, number 7, pages 41 - 48. July 1980.
50. Technology and Steel Industry Competitiveness. Congress of the United States. Office of Technology Assessment. Washington, D.C. June 1980. Pages 186 - 188, 194 - 201.
51. Hogan, W. T. Does Direct Reduction Have a Future? Iron and Steel Engineer. Volume 59, number 2, pages 57 - 58. February 1981.
52. The Making, Shaping and Treatment of Steel. United States Steel, Pittsburgh, PA. December 1970. Pages 403, 551, 553, 574.
53. Technical Guidance for Control of Industrial Process Fugitive Particulate Emissions. The U. S. Environmental Protection Agency, Research Triangle Park, NC. EPA-450/3-77-010. March 1977. Pages 84 - 100.
54. Sahagian, H. et al. Inspection Manual for Enforcement of New Source Performance Standards - Steel Producing Electric Arc Furnaces. The U.S. Environmental Protection Agency, Washington, D.C. EPA 340/1-77-007. May 1977. Pages 8 - 23.
55. Letter and attachments from Hauris, F. C., Allegheny Ludlum Steel Corporation, to Iverson, R. E., EPA/ISB. September 24, 1980. Submittal of requested information.
56. Memo and attachments from Terry, W., Midwest Research Institute, to Iverson, R. EPA/ISB. May 18, 1981. Report of source test trip to Carpenter Technology Corporation, Reading, PA.
57. Junker, A. Electric Steelmaking - The Bottom Tapping Combined Process Furnace (CPF), Part 1 - Technical Innovations. Iron and Steel Engineer. Volume 59, number 12, pp. 25 - 28. December 1981.
58. Fennelly, P. F. and P. D. Spawn. Air Pollution Control Techniques for Electric Arc Furnaces in the Iron and Steel Foundry Industry. The U.S. Environmental Protection Agency, Research Triangle Park, NC. EPA 450/2-78-024. 1978. Pages 2-1 through 2-9, 2-16.

59. Emission Test Report. AL Tech Specialty Steel Corporation. The U.S. Environmental Protection Agency, Research Triangle Park, NC. Publication number EMB report 80-ELC-7. March 1981.
60. Bohn, R. et al. Fugitive Emissions from Integrated Iron and Steel Plants. The U.S. Environmental Protection Agency, Research Triangle Park, NC. EPA-600/2-78-050. March 1978.
61. Memo and attachments from Terry, W., Midwest Research Institute, to Iversen, R., EPA/ISB. January 6, 1981. Site visit report--North Star Steel, Monroe, Michigan.
62. Memo and attachments from Banker, L., Midwest Research Institute, to Iversen, R., EPA/ISB. March 30, 1981. Source test observation report--U.S. Steel Corporation, Baytown, Texas.
63. Memo and attachments from Terry, W., Midwest Research Institute, to Iversen, R., EPA/ISB. May 18, 1981. Source test observation report-Carpenter Technology Corporation, Reading, Pennsylvania.
64. Hutten-Czapski, L. Efficient and Economical Dust Control System for Electric Arc Furnace. Sidbec-Dosco, Usine de Contrecoeur. Contrecoeur, Quebec, Canada. 12 pages.
65. Fennelly, P. F., and P. D. Spawn. Air Pollution control Techniques for Electric Arc Furnaces in the Iron and Steel Foundry Industry. U.S. Environmental Protection Agency. Research Triangle Park, NC. EPA-450/2-78-024. June 1978. 221 pages.
66. Telecon. Terry, B., Midwest Research Institute, with Sarlitto, R., Union Carbide Corporation. September 4, 1981. Information about AOD utilization.
67. Characterization, Recovery and Recycling of Electric Arc Furnace Dusts. Prepared for the U.S. Department of Commerce. Project number 99-26-09886-10. Lehigh University, Bethlehem, PA. February 1982.
68. Living Electrically: The Power Behind the Switch-on to EF Technology. World Steel Industry Handbook/United States. Volume 1, pp. 79 - 89. 1978.
69. Nicole, A. G. Electric Arc Furnace Shops in the U. S. and Canada. Iron and Steel Engineer. Volume 55, number 11, pages 79 - 71. November 1978.
70. Developments in the Iron and Steel Industry. U. S. and Canada - 1979. Iron and Steel Engineer. Volume 58, number 2, pages D1 - D22. February 1982.

71. AOD: The New Common Denominator in Stainless Steel Making. World Steel Industry Data Handbook/United States. Volume 1, pages 109 - 111. 1978.
72. Revised Standards for Basic Oxygen Process Furnaces - Background Information for Proposed Standards. Draft EIS. EPA-450/3-82-005a. The U. S. Environmental Protection Agency, Research Triangle Park, NC. December 1982.
73. GCA Corporation. Survey of Cadmium Emission Sources. The U. S. Environmental Protection Agency, Research Triangle Park, NC. EPA-450/3-81-013. September 1981.
74. Telecon. Goldman, L., Research Triangle Institute, with Hoffman, D. Granite City Works, National Steel Corporation. May 28, 1981. Discussion of KMS system for BOPFs.
75. Formadley, R. J. Granite City: Bold Modernization of an Integrated Steel Plant. Iron and Steel Engineer. Volume 57, number 8, pages SL67-SL82. August 1980.
76. Westbrook, C. W. Hot Metal Desulfurization, BOF (Basic Oxygen Furnace) Charging and Oxygen Blowing: Level 1 Environmental Assessment. Prepared by Research Triangle Institute for the U. S. Environmental Protection Agency, Research Triangle Park, NC. EPA-600/2-82-036. February 1981. pp. 45 - 46.
77. Cuscino, T. A., Jr. Particulate Emission Factors Applicable to the Iron and Steel Industry. Prepared by Midwest Research Institute for the U. S. Environmental Protection Agency, Research Triangle Park, NC. EPA-450/4-79-028. September 1979. pp. 27 - 31.
78. Supplement No. 11 for Compilation of Air Pollutant Emission Factors, Third Edition. The U. S. Environmental Protection Agency, Research Triangle Park, NC. Publication number AP-42, Supplement 11. October 1980. pp. 7.5-6, 7.5-9.
79. Nicola, A. G. Fugitive Emission Control in the Steel Industry. Iron and Steel Engineering. Volume 53, number 7, p. 25. July 1976.
80. Memo from Goldman, L., Research Triangle Institute to MacDowell, W., EPA, February 10, 1981, Types of scrap and their effects on BOPF secondary emissions.
81. Coy, D. W. et al. Pollution Effects of Abnormal Operations in Iron and Steel Making-Volume VI. Basic Oxygen Process, Manual of Practice. The U.S. Environmental Protection Agency, Research Triangle Park, NC. EPA-600/2-78-118f. June 1978. pp. 3-18.

82. Drabkin, M. and R. Helfand. A Review of Standards of Performance for New Stationary Sources - Iron and Steel Plants/Basic Oxygen Process Furnaces. The U. S. Environmental Protection Agency. EPA-450/3-78-116. November 1978.
83. American Iron and Steel Institute. Iron and Steel Producing and Finishing Works of the United States. September 1980.
84. Coleman, R. et al. Sources of Atmospheric Cadmium. The U. S. Environmental Protection Agency, Research Triangle Park, NC. EPA-450/5-79-006. August 1979.
85. Jacko, R. B. and D. W. Neuendorf. Trace Metal Emission Test Results from a Number of Industrial and Municipal Point Sources. Journal of Air Pollution Control. Volume 27, number 10, pp. 989 - 994. October 1977.
86. Jacko, R. B. et al. Functional Collection Efficiency of Electrostatic Precipitator for Open Hearth Furnace Trace Metal Emissions. Environmental Science and Technology. - Volume 10. pp. 1002 - 1005. October 1976.
87. Kirk-Othmer Encyclopedia of Chemical Technology. Third Edition. Volume 14. John Wiley & Sons, Inc. New York: 1980. pp. 200 - 231.
88. Telecon. Brooks, G. U., Radian Corporation with Anderson, M., Maine Department of Environmental Protection. March 1, 1983. Chromium emissions from leather tanning.
89. SRI International. 1982 Directory of Chemical Producers-United States. Menlo Park, California. 1982. pp. 82 - 120.
90. Telecon. Brooks, G. W., Radian Corporation with Kinsey, B., Massachusetts Division of Air Quality Control. February 23, 1983. Leather tanning chromium emissions.
91. Monsanto Research Corporation. Environmental Monitoring Near Industrial Sites - Chromium. EPA-560/6-77-016. The U. S. Environmental Protection Agency, Washington, D.C. June 1977.
92. Edwards, L.O., et al. (Radian Corporation). Trace Metals and Stationary Conventional Combustion Sources (SCCPs). (Prepared for U. S. Environmental Protection Agency, Research Triangle Park, NC). EPA Contract No. 68-02-2608. April 1980. pp. 3-1 to 3-17.
93. Reference 13, pp. 3-3 to 3-6.
94. DeAngelis, D. G. (Monsanto Research). Emissions from Coal-fired Residential Combustion Equipment. Paper No. 79-60.3, Presented at the 2nd Annual Meeting of the Air Pollution Control Association. Cincinnati, Ohio, June 24-29, 1979.
95. Letter and attachments from Blum, E. D., Union Oil to Lahre, T.,

- U. S. EPA. February 27, 1984. Nickel and chromium levels in distillate oils.
96. Cato, G. A., et al. Field Testing: Application of Combustion Modifications to Control Pollutant Emissions from Industrial Boilers - Phase 1. EPA-650/2-74-078a. October 1974.
 97. Surprenant, N. F., et al. Emissions Assessment of Conventional Stationary Combustion Systems; Volume 1. Gas- and Oil-fired Residential Heating Sources. EPA-600/7-79-0296. May 1979.
 98. Letter from Blum, E. D., Union Oil to Lahre, T., U. S. EPA. January 18, 1984. Nickel and chromium levels in oils.
 99. Baig, S. et al. Conventional Combustion Environmental Assessment Final Report. Draft. Prepared for U. S. Environmental Protection Agency, Research Triangle Park, NC. Contract #68-02-3138. July 1981. p. 3-51.
 100. Baig, S. et al. Conventional Combustion Environmental Assessment Final Report. Draft. Prepared for U. S. Environmental Protection Agency, Research Triangle Park, NC. Contract #68-02-3138. July 1981. pp. 3-7 to 3-15.
 101. Lim, M. Y. Trace Elements from Coal Combustion - Atmospheric Emissions. IEA. Coal Research Report No. ICTIS/TROS. London, England. May 1979. pp. 17 - 24.
 102. Reference 92, p. 4-18
 103. Reference 13, p. 3-53
 104. Reference 13, pp. 5-11 to 5-23.
 105. Reference 93, pp. 4-34 to 4-57.
 106. Shih, C. C., et al. Emissions Assessment of Conventional Stationary Combustion Systems: Volume III, External Combustion Sources for Electricity Generation. (Prepared for Industrial Environmental Research Laboratory, U. S. EPA, Research Triangle Park, NC). EPA Contract No. 68-02-2197. November 1980.
 107. Krishnan, E. R. and G. V. Hellwig. Trace Emissions from Coal and Oil Combustion. Environmental Progress. 1(4): 290-295. 1982.
 108. Surprenant, N. F., et al. Emissions Assessment of Conventional Stationary Combustion Systems: Volume V, Industrial Combustion Sources (Draft Final Report). (Prepared for Industrial Environmental Research Laboratory, U. S. EPA, Research Triangle Park, NC). EPA Contract No. 68-02-2197. October 1980.
 109. Levy, A., et al. A Field Investigation of Emissions from Fuel Oil Combustion for Space Heating. API Publication 4099. November

- 1, 1971.
110. Baig, S. et al. Conventional Combustion Environmental Assessment Final Report. Draft. Prepared for U. S. Environmental Protection Agency, Research Triangle Park, NC. Contract #68-02-3138. July 1981. pp. 4-1 to 4-66.
 111. Surprenant, N. F., et al. Emissions Assessment of Conventional Stationary Combustion Systems: Volume IV. Commercial/Institutional Combustion Sources. October 1980. (Prepared for IERL, U. S. EPA, Research Triangle Park, NC). EPA Contract No. 68-02-2197.
 112. Klein, D. H., et al. Pathways of 37 Trace Elements Through Coal-fired Power Plants. Environmental Science and Technology. 9(10): 973-979. October 1975.
 113. Hulett, L. D., Jr., et al. Chemical Species in Fly Ash from Coal-burning Power Plants. Science. 210: 1356-1358. 1980.
 114. Henry, W. M. and K. T. Knapp. Compound Forms of Fossil Fuel Fly Ash Emissions. Environmental Science and Technology. 14(4): 450-456. 1980.
 115. Gendreau, R. M., et al. Fourier Transform Infrared Spectroscopy for Inorganic Compound Speciation. Environmental Science and Technology. 18(8): 990-995. 1980.
 116. Blaha, J. J., et al. Raman Microprobe Analysis of Stationary Source Particulate Pollutants. Reports of EPA Contracts EPA-1AG-D7-F1186 and EPA-1AG-78-D-F0367. Available from NTIS, Springfield, Virginia, PB80-202708.
 117. Barrett, K. W. (Mitre Corp.). A Review of Standards of Performance for New Stationary Sources - Portland Cement Industry. (Prepared for U. S. Environmental Protection Agency, Research Triangle Park, NC). EPA - Contract No. 68-02-2526. March 1979.
 118. Compilation of Air Pollutant Emission Factors. Third Edition. U. S. Environmental Protection Agency, Research Triangle Park, NC. August 1977. pp. 8.6-1 to 8.6-4.
 119. Katari, Vishnu et al. (PEDCo, Inc.). Trace Pollutant Emissions from the Processing of Non-Metallic Ores. (Prepared for U. S. Environmental Protection Agency, Research Triangle Park, NC). EPA Contract No. 68-01-1321. November 1974. pp. 2-1 to 2-21.
 120. National Emissions Data System (NEDS). Monitoring and Data Analysis Division, U. S. Environmental Protection Agency. Research Triangle Park, NC. 1983.
 121. Marr, H. E. et al. Trace Elements in the Combustible Fraction of Urban Refuse. U. S. Bureau of Mines. College Park Metallurgy

- Research Center, College Park, Maryland. Undated.
122. Gerstle, R. in. and D. N. Albrinck. Atmospheric Emissions of Metals from Sewage Sludge Incineration. Journal of Air Pollution Control Association. 32(11): 1119-1123. 1982.
 123. Hefland, R. M. (Mitre Corp.). A Review of Standards of Performance for New Stationary Sources - Incinerators. EPA-450/3-79-010. (Prepared for the U. S. Environmental Protection Agency, Research Triangle Park, NC). March 1979. p. 4-10.
 124. Hefland, R. M. (Mitre Corp.). A Review of Standards of Performance for New Stationary Sources - Sewage Sludge Incinerators. EPA-450/2-79-010. (Prepared for the U. S. Environmental Protection Agency, Research Triangle Park, NC). March 1979. p. 4-11.
 125. Environmental Engineer's Handbook, Volume 3 - Land Pollution: Edited by Liptak, B. G. Published by Chilton Book Company, Radnor, Pennsylvania. 1974. pp. 253-267.
 126. Golembiewski, M., et al. Environmental Assessment of Waste-to-Energy Process: Braintree Municipal Incinerator. EPA-600/7-80-149. December 1978.
 127. Law, S. L. and G. E. Gordon. Sources of Metals in Municipal Incinerator Emissions. Environmental Science and Technology. 13(4): 432-438. April 1979.
 128. Greenberg, R.R. et al. Composition and Size Distribution of Particles Released in Refuse Incineration. Environmental Science and Technology. 12(5):566-573. 1978.
 129. Greenberg, R. R. et al. Composition of Particles Emitted from the Nicosia Municipal Incinerator. American Chemical Society. 12(12):1329-1332. 1978.
 130. Cross, Jr., F. L. et al. Metal and Particulate Emissions from Incinerators Burning Sewage Sludge and Mixed Refuse. Paper presented at the 1970 National Incinerator Conference of the American Society of Mechanical Engineers.
 131. Trichon, M. et al. The Fate of Trace Metals in a Fluidized Bed Sewage Sludge Incinerator. Paper presented at the 74th Annual Meeting of the Air Pollution Control Association. 1981.
 132. Bennett, R. L. and K. T. Knapp. Characterization of Particulate Emissions from Municipal Wastewater Sludge Incinerators. Environmental Science and Technology. 16(12): 831-836. 1982.

133. Pelland, A. S., et al. (Radian Corporation). Definition of the Air Toxics Problem at the State/Local Level. Final Report. EPA Contract No. 68-02-3513, assignment 45. (Prepared for the U. S. Environmental Protection Agency, Research Triangle Park, NC). June 1984.
134. Letter and attachments from Courcier, J., U. S. EPA Region I to Mitsch, B. F., Radian Corporation. February 24, 1983. Sewage sludge incinerators.
135. Letter and attachments from Giaccone, F. W., U. S. EPA Region II to Mitsch, B. F., Radian Corporation. March 21, 1983. Sewage sludge incinerators.
136. Letter and attachments from Mitchell, J. W., Georgia Department of Natural Resources to Wilburn, J. T., U. S. EPA Region IV. March 21, 1983. Sewage sludge incinerators.
137. Letter and attachments from McCann, R. B., Kentucky Natural Resources and Environmental Protection Cabinet to Mitsch, B. F., Radian Corporation, March 21, 1983. Sewage sludge incinerators.
138. Letter and attachments from Nuncio, M. G., U. S. EPA Region VII to Mitsch, B. F., Radian Corporation, March 7, 1983: Sewage sludge incinerators.
139. Letter and attachments from Hooper, M. H., U. S. EPA Region X to Mitsch, B. F., Radian Corporation. April 4, 1983. Sewage sludge incinerators.
140. Survey of Cadmium Emission Sources: GCA Corporation. New Bedford, Massachusetts. EPA-450/3-81-013. September 1981.
141. Coleman, R., et al. Assessment of Human Exposure to Atmospheric Cadmium. EPA45705-79-007. June 1979.
142. Telecon. Brooks, G. W., Radian Corporation with Pucorius, P., Pucorius and Associates. March 2, 1983. Cooling tower emissions.
143. Telecon. Brooks, G. W., Radian Corporation with McCloskey, J., Betz Laboratories. February 22, 1983. Cooling tower emissions.
144. Telecon. Brooks, G. W., Radian Corporation with Augsburg, B., Pucorius and Associates. February 23, 1983. Cooling tower emissions.
145. Telecon. Brooks, G. W., Radian Corporation with Townsend, J., Cooling Tower Institute. February 22, 1983. Cooling tower emissions.

146. Alkezweeny, A. J., et al. Measured Chromium Distributions Resulting from Cooling Tower Drift. Presented at the Cooling Tower Environment - 1974 Symposium. College Park, Maryland, March 4 - 6, 1974.
147. Jallouk, P. A., et al. Environmental Aspects of Cooling Tower Operation. Presented at the Third Environmental Protection Conference of the U. S. Energy Research and Development Administration. Chicago, Illinois, September 23 - 26, 1975.
148. Taylor, F. G., et al. Cooling Tower Drift Studies at the Paducah, Kentucky Gaseous Diffusion Plant. Presented at the Cooling Tower Institute Annual Meeting. Houston, Texas, January 22 - 24, 1979.
149. Baig, S. et al. Conventional Combustion Environmental Assessment Final Report. Draft. Prepared for U. S. Environmental Protection Agency, Research Triangle Park, NC. Contract #68-02-3138. July 1981. pp. .4-9 to 4-13.
150. RTI. Review of National Emission Standard for Asbestos (Draft). Prepared for the U. S. Environmental Protection Agency, Research Triangle Park, North Carolina. EPA contract number 68-02-3056. October 1981.
151. Control Techniques for Asbestos Air Pollutants. The U. S. Environmental Protection Agency, Research Triangle Park, North Carolina. Publication number AP-117. February 1973.
152. Telecon. Acurex Corporation with Clifton, R. A., U. S. Bureau of Mines. July 1980. Asbestos Emissions.
153. Telecon. Acurex Corporation with Wood, G., U.S. Environmental Protection Agency. July 1980. Asbestos Emissions and Controls.
154. Compilation of Air Pollutant Emission Factors. Third Edition - Supplement 11. U. S. Environmental Protection Agency, Research Triangle Park, NC. October 1980. pp. 7.2-1 to 7.2-4.
155. Coke Wet Quenching - Background Information for Proposed Standards, Draft Report. Emission Standards and Engineering Division, U. S. Environmental Protection Agency, Research Triangle Park, NC. May 1981. pp. 9-18 to 9-21.

SECTION 5

SOURCE TEST PROCEDURES

Source sampling and analysis procedures have not been published by the U. S. EPA for chromium emissions. The sampling and analysis methods presented in this chapter represent a collection of chromium air emission detection and quantification techniques that have been published in the open literature as viable methods. The presentation of these published methods in this report does not constitute endorsement or recommendation or signify that the contents necessarily reflect the views and policies of the U. S. EPA.

LITERATURE REVIEW OF SAMPLING METHODS

Because of its physical and chemical properties, chromium emissions in air are highly unlikely to be in a gaseous form.¹ Chromium-containing particulate emissions behave like other particulate matter to the extent that they may be collected by whatever techniques are suitable or applicable in a given application.² The U. S. EPA has promulgated Methods 5 and 17 for measuring particulate emissions from certain new stationary sources to indicate compliance with new source performance standards (NSPS).³ Method 5 uses an out-of-stack particulate filtration technique and Method 17 uses an in-stack filtration technique.

The National Air Sampling Network uses high-volume (hi-vol) filters to collect ambient particulate samples.⁴ Typical filter media have included cellulose, polyethylene, polystyrene, and glass fiber. Care should be taken because some filter media are contaminated with large amounts of chromium. As an example, millipore filter material

was found to contain chromium at a level of 17,600 ppb.^{1,5,6} In contrast to the hi-vol, Bagnoche and Risby sampled for chromium particulates with a low-volume sampler using porous polymer filter media.⁷

In one set of tests, air samples were collected for organic chromium species at chromium chemical plants, electroplating plants, leather tanneries, and ferrochromium plants. These samples were taken using the sampling train illustrated in Figure 46. Ambient air was pumped through a glass fiber filter and an XAO-2 resin tube at between 230 and 330 cm³/s (0.0081 - 0.012 ft³/s) over a period of 4 hours. The volume of gas sampled in each run was measured by a dry test meter. After sampling, the resin tubes were capped and sent for analysis.

Chromic acid mists in air have successfully been collected by: absorption using water or caustic solutions in an impinger or sintered-glass bubbler, by absorption in distilled water and alkaline solutions, and by filtration with absorbent paper.^{1,2,8,9} Of these methods, filtration offers the greatest collection efficiency and ease of collection. The AA type of membrane filter has a 0.8 μ pore size and therefore provides a highly retentive matrix for chromium particulates in the mists.⁹

LITERATURE REVIEW OF ANALYTICAL METHODS

Extraction Procedures

Prior to analysis, chromium samples may need to be concentrated or extracted from potential sample contaminants. One of the most widely used extraction techniques for atmospheric chromium samples is liquid-liquid solvent extraction.¹ In this method an immiscible organic solvent is equilibrated with an aqueous solution containing chromium in a complexed state. The phases are then separated and the organic phase, in which the chromium species preferentially concentrates, is analyzed or undergoes further separation/concentration processes. Ammonium pyrrolidine

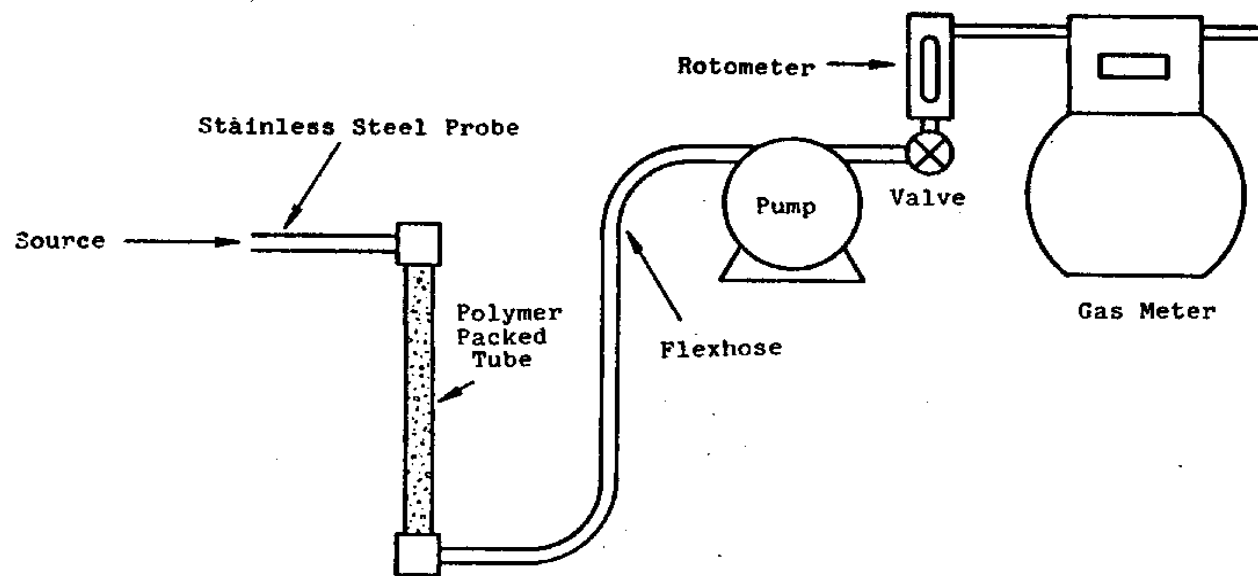

Figure 46. Organic chromium species sampling configuration.⁶

dithiocarbamate (APDC) is a commonly used complexing agent for chromium extraction.¹⁰ Generally, methyl isobutyl ketone (MIBK) is used as the organic solvent.¹¹ This extraction technique only recovers hexavalent chromium; if trivalent chromium is to be extracted, it must first be oxidized. The oxidation step may be accomplished by treatment of the sample with silver nitrate and potassium peroxydisulfate or with potassium permanganate and sodium azide. The solvent extraction technique is popular because it allows for the elimination of interfering elements and for increased sensitivity through concentration of the sample.

Snyder, et al. employed the solvent extraction technique in tests of several chromium sources.¹² Prior to the solvent extraction procedure, the hi-vol filter samples containing chromium were dried at 60°C (140°F) to constant weight, placed in a Pyrex® boat, and low temperature ashed at 425 watts until the plasma discharge reverted to a blue color indicating completion of the ashing. The typical ashing time was two hours. The ashed samples were quantitatively transferred to a 25 mm Pyrex® extraction thimble (coarse grade). The extraction thimble was then placed into an extraction apparatus which had been charged with 8 ml of 19 percent hydrochloric acid (HCl) and 32 ml of 40 percent nitric acid (HNO₃). The extraction flask was fitted with an Allihn condenser and acid was refluxed over the sample for three hours. After this time the Allihn condenser was removed and the acid extract was concentrated to 20 ml on a hotplate. After cooling, the acid concentrates were quantitatively transferred to 100 ml volumetric flasks, diluted with distilled water, and transferred to 200 ml polyethylene sample bottles for storage.

The solvent extraction procedure carried out by Snyder, et al. was a modification of that described by Midgett and Fishman.¹³ The extraction of hexavalent chromium in the samples was accomplished by first pipeting exactly 20 ml of sample into an acid-cleaned 60 ml bottle. After adding two drops of 0.1 percent methyl violet indicator, either NaOH or HNO₃ was added until the indicator changed from yellow to blue-blue green (pH 2.4-2.6). Then, 5 ml of 5 percent APDC solution, 3 ml of saturated sodium sulfate (Na₂SO₄) solution, and 20 ml of MIBK were pipetted into the 60 ml bottle. The bottle was

capped and shaken on a wrist-action shaker for 3-5 minutes. The extracted hexavalent chromium (or total chromium if trivalent chromium was oxidized) is contained in the top organic layer of the solution.¹²

Analysis Procedures

A wide variety of analytical methods have been used to determine and quantify chromium levels in environmental samples. A number of these methods are summarized in Table 46. Analytical methods that have been used include titration of liberated iodine with standardized sodium thiosulfate solution, colorimetry with hematoxylin or sym-diphenylcarbazine, and field analysis by means of an impregnated filter paper based on the colorimetric reaction between chromium and sym-diphenylcarbazine and comparison with permanent standards. The iodide-thiosulfate method is subject to interferences from a large number and variety of compounds because of its nonspecific iodide reaction and the tendency for errors in color definition. The hematoxylin method is a visual colorimetric technique and is intended only as a check for very small amounts of chromium. The colorimetric diphenylcarbazine method does not react with trivalent chromium but produces a color only with hexavalent chromium.⁹

Until the last decade or two, spectrophotometric methods utilizing the chromium diphenylcarbazine reaction were predominantly used for chromium analysis purposes. This analytical procedure involves forming colored molecular species which absorb radiation in the visible or near ultraviolet range of the spectrum. The amount of radiation absorbed is compared with a previously obtained calibration plot and is related to the metal concentration by the calibration data. Photometric measurements at concentrations near 400 mg/liter can be made with a precision of about 30 percent. Accuracy depends on the promptness of the analysis. Spectrophotometric comparisons should be made at least five but not more than 15 minutes after the addition of reagent to the sample.¹

TABLE 46. INSTRUMENTAL METHODS FOR THE DETERMINATION OF CHROMIUM^a

Analytical Method	Important Application	Detection Limit	Precision (relative standard deviation/sample size)	Relative Error	Interfering Substances	Selectivity
Atomic absorption spectroscopy (flameless) industrial waste-waters; air pollution particulates	Biologic solids and fluids:tissue, blood, urine;	0.2 µg/liter	15% (6 µg/liter)	7% (5 µg/liter)	No interfering substances are reported for samples of urine ^a and blood. ^b Less than 10% interference is observed for Na ⁺ , K ⁺ , Ca 2+, Mg ²⁺ , Cl ⁻ , F ⁻ , SO ₂ ²⁻ , and PO ₄ ³⁻ in certain industrial wastewaters.	Total chromium is measured.
Atomic absorption spectroscopy (flame)	Fresh and saline waters, industrial waste fluids, dust and sediments, biologic solids and liquid, alloys	.05 µg/liter	5% (3 µg/liter)	3% (5 µg/liter)	Interfering substances present in the original sample are usually not extracted into the organic solvent.	All of the extracted chromium is measured, but only Cr(VI) is extracted from the original sample unless oxidative pre-treatment is used.
Neutron activation analysis	Air pollution particulates, fresh and saline waters, biologic liquids and solids, sediments, metals, foods	Sensitivity varies with sample and processing conditions. Typical sensitivities are: 0.2 ng/g ^f (petroleum), 10 ng/g (environmental samples), 0.2 µg/g ^h (biologic material)	3% (8 µg/g) 6% (6 µg)	25% (100 ng/cu•m) (Air pollution particulates) 20% (2.4 µg/g) (orchard leaves)	Interference may arise from gamma ray activity from other elements, especially NA-24, CI-38, K-42, and Mn-56. Bremsstrahlung from P-32 may be troublesome.	Total chromium is measured.
Spectrophotometric	Natural water and industrial waste solutions having 5 to 400 µg/liter hexavalent chromium may be analyzed. Higher concentrations must be reduced by dilution. Air pollution particulates.	3 µg/liter	3% (400 µg/liter)	2% (0.4 µg/g)	Iron, vanadium, and mercury may interfere.	This method determines only the hexavalent chromium in solution.

TABLE 46. (CONTINUED) INSTRUMENTAL METHODS FOR THE DETERMINATION OF CHROMIUM^a

Analytical Method	Important Application	Detection Limit	Precision (relative standard deviation/sample size)	Relative Error	Interfering Substances	Selectivity
X-ray fluorescence	Atmospheric particulates, geologic materials	2 to 10 µg/g (liver) 1.5 µg/g (coal)	4% (25 µg/g) (coal)	1% to 4% (120 µg/cm ²) (air particulates)	The particle size of the sample and the sample matrix may influence the observed measurements.	Total chromium is determined.
Emission spectroscopy (arc)	A wide variety of environmental samples	0.5 ng	19% (0.2 µg/m ³) 6% to 12% (50 µg/liter) ¹¹	10% to 16% (50 µg/liter)		Total chromium is determined.
Emission spectroscopy-inductively coupled plasma source samples	A wide variety of biological and environmental samples	0.0003, 0.001 µg/ml	~ 5%		No interfering	Total chromium is determined.

^a References 5, 10, 14-30.

Recently, spectrophotometric methods have been largely replaced by methods that are more sensitive and/or convenient including atomic absorption spectrometry, neutron activation analysis, emission spectroscopy, and x-ray fluorescence.

Atomic Absorption Spectrometry (Flame)--

The most prevalently used of the newer procedures is atomic absorption spectrometry. In this method, a previously prepared (extracted) chromium sample is injected into an air-acetylene flame through which light of 357.9 nm wavelength is passed. The flame atomizes the sample and light from the lamp is selectively absorbed by chromium atoms in proportion to their concentration in the vapor. A photodetector measures the intensity of the 357.9 nm radiation after its passage through the flame and compares it with the intensity of the original line spectrum emitted by the lamp. The results are converted and calibrated to be read out directly as concentration values. The air-acetylene flame can be replaced with a nitrous oxide-acetylene flame to provide greater sensitivity and freedom from chemical interference.

The absorption of chromium in this procedure has been found to be suppressed by the presence of iron and nickel.³¹ If the analysis is performed in a lean flame, this interference can be lessened, but sensitivity will also be reduced. The interference caused by iron and nickel does not occur in the nitrous oxide-acetylene flame.³²

Atomic Absorption Spectrometry (Flameless)--

Flameless atomic absorption spectrometry is a relatively new variation of the previously described method in which the sample is atomized directly in a graphite furnace, carbon rod, or tantalum filament instead of a flame. This innovation frequently results in a tenfold to thousandfold increase in sensitivity and can eliminate the need for sample preparation in certain cases.

The analysis of chromium by the flameless atomic absorption technique is influenced by a number of factors. Henn (1974) observed a variation in absolute sensitivity as a function of sample volume and ascribed the effect to the manner in which the sample was distributed in the graphite furnace.³³ Schaller et al. (1973) found that the specificity of the method was influenced by smoke and nonspecific absorption during atomization.¹⁴ This difficulty was satisfactorily resolved by modifying the charring procedure to destroy the smoke-causing components.

Neutron Activation Analysis--

Neutron activation analysis is probably second only to atomic absorption spectrometry in frequency of use for analysis of chromium samples. Its popularity stems from three factors: its great sensitivity, its wide applicability to a variety of sample types with minimal sample preparation, and its ability to determine a variety of elements from a single sample.

Neutron activation analysis is one of the most sensitive modern analytical techniques for the determination of trace elements such as chromium. Samples and known standards are irradiated in a nuclear reactor during which time neutrons are captured by various nuclides in the sample. By comparison with the activity induced in the standards, the amount of sample isotope can be calculated. The induced activity, and hence the sensitivity for determining the parent nuclide, is proportional to the amount of the parent isotope present. Neutron fluxes of 10^{12} to 10^{14} neutrons $\text{cm}^{-2} \text{sec}^{-1}$ are easily available in modern reactors; thus, for irradiations of reasonable length (a few seconds to a few days) most elements can be determined at levels of 10^{-8} to 10^{-10} grams.³⁴

The commonly used reaction for chromium activation analysis is $^{50}\text{Cr}(n, \gamma)^{51}\text{Cr}$. Chromium-50 has a thermal neutron absorption cross section of 17.0 barns and a natural abundance of 4.31 percent.³⁵ The resulting ^{51}Cr decays with a half-life of 27.8 days and is usually determined by measuring the intensity of the 320-keV gamma ray.

The minimum chromium concentrations that can be detected varies

with sample type and processing conditions. Greater sensitivities generally can be achieved for given irradiation conditions if the sample is chemically processed to separate and concentrate the chromium fractions. McClendon reported sensitivities at the parts per billion level for chromium extracted from previously irradiated biological and environmental samples.³⁶ The precision and accuracy of neutron activation analyses of chromium also vary with sample type and processing conditions but may be generally characterized as good to excellent. Relative standard deviations of ± 10 percent have been commonly reported for samples containing chromium in the microgram per gram and nanogram per gram ranges.^{17,19}

The use of neutron activation for chromium analyses does have one disadvantage. Due to intense x-ray or bremsstrahlung activity from ^{24}Na , ^{38}Cl , ^{42}K , ^{56}Mn , and ^{32}P in many samples, the irradiated sample usually must be cooled several weeks before measuring the chromium concentration. The procedure is thus not amenable to rapid or on-line applications. The lengthy cooling period can be reduced to about 24 hours by chemically separating the offending nuclides from the irradiated chromium.³⁶

Emission Spectroscopy--

In this analytical procedure the prepared chromium sample is excited with a flame, arc, spark or plasma and the resulting light is dispersed with a monochromator. The characteristic emission lines of each excited element are recorded electronically or on a photographic plate. The concentration of each element is determined by comparing the density of its emission line with that of an internal or external standard. The preparation of each sample depends in part on the mode of excitation used. Generally, samples are dissolved and the solution is deposited on metal or graphite electrodes which are dried prior to analysis. The precision and accuracy achievable with emission spectroscopy varies with sample type and actual chromium concentration.¹ Sealy and Skogerboe have monitored air containing 0.2 mg/liter chromium with a precision of ± 19 percent.²⁷ Emission spectroscopy using an inductively coupled plasma as a light source has been shown to be a very sensitive analytical method.

Sensitivities down to 0.3 ppb have been reported using direct aspiration of sample solutions.³⁷

X-Ray Fluorescence--

With x-ray fluorescence the sample is first irradiated with low-energy x-ray or gamma photons which displace K or L orbital electrons from elements of interest such as chromium. A series of characteristic x-ray lines are then emitted as the electron defects are filled by electrons from higher orbitals.¹ The intensity of the fluorescence is related to the concentration of the metal in the sample by comparison with radiation from an internal standard.

Sample preparation is important in x-ray fluorescence analysis because particle size and shape affect the extent to which the irradiating beam is scattered or absorbed. Also, quantitative measurements of trace elements like chromium can be complicated by radiation from surrounding atoms. To minimize these matrix effects, solid samples, such as air particulates, can be pressed into thin wafers.¹

As with several other analytical techniques, the precision and accuracy of x-ray fluorescence varies with sample type and pollutant concentration level. In an analysis of samples of air particulates containing 120 mg/cm³ chromium, a relative error of 1 to 4 percent was obtained with x-ray fluorescence.²⁶

The energy-dispersive x-ray fluorescence analytical technique is not yet in widespread use for chromium measurements. However, it appears to have considerable potential for rapid, accurate analysis of air pollution particulates (containing chromium and other trace metals) which have more or less homogeneous surfaces.¹

Other--

The concentration of chromic acid mists in air can be estimated by a direct field method described by Ege and Silverman.^{38,39,40} The Ege-Silverman technique is a spot-test method using phthalic anhydride and sym-diphenylcarbazine. The concentration of chromic acid mists in the atmosphere can also be quickly estimated using a lightweight sampler developed by the Mine Safety Appliances Co.^{41,42} The operating principle of this device is based on the phthalic anhydride/sym-diphenylcarbazine method developed by Ege and Silverman.

REFERENCES FOR SECTION 5

1. Towill, L.E., et al. Reviews of the Environmental Effects of Pollutants: III. Chromium. ORNL/EIS-80 and EPA-600/1-78-023. May 1978. pp. 28-55.
2. Sullivan, R.J. Preliminary Air Pollution Survey of Chromium and Its Compounds. EPA/APTD 69-34. October 1969. pp. 33-45.
3. Code of Federal Regulations. Title 40, Part 60. Appendix A. pp. 387-404 and 498-515. Office of the Federal Register, Washington, D.C. 1982:
4. Thompson, R.J., et al. Analysis of Selected Elements in Atmospheric Particulate Matter by Atomic Absorption, Preprint. Presented at the Instrument Society of American Symposium. New Orleans, Louisiana. May 5-7, 1969.
5. Bhagat, S.K., et al. Trace Element Analysis of Environmental Samples by Neutron Activation Method. Journal of the Water Pollution Control Federation. 43(12): 2414-2413. 1971.
6. Snyder, A.D. Environmental Monitoring Near Industrial Sites: Chromium. EPA-560/6-77-016. June 1977. pp. 31-33.
7. Begnoche, B.C. and T.H. Risby. Determination of Metals in Atmospheric Particulates Using Low-Volume Sampling and Flameless Atomic Absorption Spectrometry. Analytical Chemistry. 47:1041-1045. 1976.
8. West, P.W. Chemical Analysis of Inorganic Pollutants. Chapters 19 in Air Pollution, Volume II, 2nd Edition. A.C. Stern, Ed. Academic Press, New York. 1968.
9. Criteria for a Recommended Standard - Occupational Exposure to Chromic Acid. National Institute for Occupational Safety and Health, Washington, D.C. 1973.
10. Goulden, P.D., et al. Automated Solvent Extraction for the Determination of Trace Metals in Water by AAS. Am. Lab. August: 10-17. 1973.
11. Brown, E., et al. Methods for Collection and Analysis of Water Samples for Dissolved Minerals and Gases. Techniques of Water-Resources Investigations of the United States Geological Survey. U.S. Government Printing Office. Washington, D.C. 160 pp. 1970.
12. Reference 6, pp. 37-56.

13. Midgett, M.R. and M. J. Fishman. Determination of Total Chromium in Fresh Waters by Atomic Absorption. Atomic Absorption Newsletter. 6: 128-131. 1967.
14. Schaller, K. H., et al. The Quantitative Determination of Chromium in Urine by Flameless Atomic Absorption Spectroscopy. Atomic Absorption Newsletter. 12(6): 147-150. 1973.
15. Morrow, R.W. and R.J. McElhaney. Determination of Chromium in Industrial Effluent Water by Flameless Atomic Absorption Spectroscopy. Atomic Absorption Newsletter. 13(2): 45-46. 1974.
16. Gilbert, T.R. and A.M. Clay. Determination of Chromium in Sea Water by Atomic Absorption Spectrometry. Anal. Chim. Acta (Netherlands). 67: 289-295. 1973.
17. Shah, K.R., et al. Determination of Trace Elements in Petroleum by Neutron Activation Analysis. Journal of Radioanalytical Chemistry (Switzerland-Hungary). 6: 413-422. 1970.
18. Spyrou, N.M., et al. Realistic Detection Limits for Neutron Activation Analysis of Biological Samples. Proceedings of a Symposium on Nuclear Techniques in Comparative Studies of Food and Environmental Contamination. Otaniemi, Finland. International Atomic Energy Agency. Vienna, Austria. pp. 471-487. 1974.
19. Harrison, P.R., et al. Areawide Trace Metal-Concentrations Measured by Multielement Neutron Activation Analysis. Journal of the Air Pollution Control Association. 21: 563-570. 1971.
20. Dams, R., et al. Nondestructive Neutron Activation Analysis of Air Pollution Particulates. Analytical Chemistry. 42(8): 861-867. 1970.
21. De Goeij, J.J. M., et al. Neutron Activation Analysis Trace Element Studies of Dover Sole Liver and Marine Sediments. Proceedings of a Symposium on Nuclear Techniques in Comparative Studies of Food and Environmental Contamination. Otaniemi, Finland. International Atomic Energy Agency. Vienna, Austria. pp. 189-200. 1974.
22. American Public Health Association, American Water Works Association, and Water Pollution Control Federation. Standard Methods for the Examination of Water and Wastewater. 13th Edition. American Public Health Association. Washington, D.C. 874 pp.
23. Sandell, E.B. Colorimetric Determination of Traces of Metals. 3rd Edition. Interscience Publishers, Inc. New York. 1959. 1032 pp.

24. Kemp, K., et al. Trace Multi-element Analysis of Biological Tissue by Proton-induced X-Ray Fluorescence Spectroscopy. Report Riso-M-1732. Danish Atomic Energy Commission. Roskilde, Denmark. 22 pp. 1974.
25. Kuhn, J.K. Trace Elements in Whole Coal Determined by X-ray Fluorescence. Norelco Report. 20(3): 7-10. 1973.
26. Jaklevic, J.M., et al. Application of X-ray Fluorescence Techniques to Measure Elemental Composition of Particles in the Atmosphere. Analytical Methods Applied to Air Pollution Measurements. R.K. Stevens and W.F. Herget, Eds. Ann Arbor Science Publishers, Inc. Ann Arbor, Michigan. 1974. pp. 123-146.
27. Seely, J.L. and R.K. Skogerboe. Combined Sampling - Analysis Method for the Determination of Trace Elements in Atmospheric Particulates. Analytical Chemistry. 46: 415-421. 1974.
28. Barnard, W.M. and M.J. Fishman. Evaluation of the Use of the Heated Graphite Atomizer for the Routine Determination of Trace Metals in Water. Atomic Absorption Newsletter. 12(5): 118-124. 1973.
29. Fassel, V.A. and R.N. Kniseley. Inductively Coupled Optical Emission Spectroscopy. Analytical Chemistry. 46: 1110-1120A. 1974.
30. Boumanns, P.W.J.M. and F.J. deBoer. Studies of an Inductively Coupled - High-Frequency Argon Plasma for Optical Emission Spectrometry: II. Compromise Conditions for Simultaneous Multi-element Analysis. Spectrochim. Acta. 30B: 309-334. 1975.
31. Ottaway, J.D., et al. Interferences in the Determination of Transition Elements by Atomic Absorption Spectrometry. Proceedings of the Third International Congress of Atomic Absorption and Atomic Fluorescence Spectrometry. John Wiley & Sons. New York. 1973. pp. 107-123.
32. U.S. Environmental Protection Agency. Manual of Methods for Chemical Analysis of Water and Wastes. EPA-625/6-74-003. Washington, D.C. 1974.
33. Henn, E.L. - Determination of Trace Metals in Polymers by Flameless Atomic Absorption with a Solid Sampling Technique. Anal. Chim. Acta (Netherlands) 73: 273-281. 1974.
34. Fulkerson, W. and H.E. Goeller. Cadmium, The Dissipated Element. ORNL-NSF-EP-21. Oak Ridge National Laboratory. Oak Ridge, Tennessee. 1973.
35. Robertson, D.E. and R. Carpenter. Neutron Activation Techniques for the Measurement of Trace Metals in Environmental Samples. NAS-NS-3114. U.S. Atomic Energy Commission Technical Information Center. Oak Ridge, Tennessee. 1974.

36. McClendon, L.T. Method Measures Trace Chromium. Chemical Engineering News. 52: 23. 1974.
37. Environmental Instrumentation Group. Instrumentation for Environmental Monitoring - Water. Volume 2. Lawrence Berkeley Laboratory. Berkeley, California. 1973. p.5.
38. Ege, J.F., Jr. and L. Silverman. Stable Colorimetric Reagent for Chromium. Analytical Chemistry. 19: 693. 1947.
39. Silverman, L. and J.F. Ege, Jr. A Rapid Method for Determination of Chromic Acid Mist in Air. J. Ind. Hyg. Toxicol. 29: 136. 1947.
40. Silverman, L. and J.F. Ege, Jr. Chromium Compounds in Gaseous Atmospheres. U.S. Patent 2,483,108. 1949; CA-Bulletin Cancer Progress. 44:490. 1950.
41. MSA Chromic Acid Mist Defector. Mine Safety Appliances Co. Bulletin. 0811-8. 1959. 42. MSA Samplair. Catalog of Industrial Safety Equipment. Mine Safety Appliances Co. Catalog 7-B, Section 3, p. 38. Pittsburgh, Pennsylvania. 1957.
42. MSA Samplair. Catalog of Industrial Safety Equipment. Mine Safety Appliances Co. Catalog 7-B, Section 3, p. 38, Pittsburgh, Pennsylvania. 1957.