

VOC Fugitive Losses: New Monitors, Emission Losses, and Potential Policy Gaps

2006 INTERNATIONAL WORKSHOP



Office of Air Quality Planning and Standards
Research Triangle Park
Office of Solid Waste and Emergency Response
Washington, DC
October 25-27, 2006

Notice

Although this document was funded under contract number 68-W-03-038 and published by the U.S. Environmental Protection Agency, it does not necessarily reflect the views of the Agency and no official endorsement should be inferred. Mention of trade names or commercial products does not constitute endorsement or recommendation for use.

Preface

In recent months, studies have been published that show a surprising quantity of hitherto unsuspected quantities of volatile organic chemicals (VOCs) are lost (emitted) nationally by the processing, distribution, and consumption of petroleum and petroleum byproducts. The studies utilized open-path spectroscopy techniques and infrared (IR) video cameras to detect the releases, and they indicate that surprisingly high levels of fugitive VOC losses (currently defined as “leaks”) may be emitted on a routine basis from storage tanks, pumps, pipes, cooling towers and wastewater separators among other operations. One study suggests that actual VOC emissions could be more than fifteen times the amounts previously estimated. These emissions are extremely important for two reasons: (1) many are end-products of the refining process, which means they are both volatile and toxic and (2) they occur throughout the national energy network, ranging from well-head to refining to distribution to storage and retailing.

This workshop was held to summarize the recent IR camera, differential absorption light detection and ranging (DIAL) spectroscopy, and radial-plume mapping spectroscopy findings and relate them to estimation methods now in use. Attendees reviewed ongoing and imminent national and state studies, as well as contract/grant resources and test sites potentially available for further confirmation studies. Also discussed were the options available to national and state regulators for addressing these fugitive VOC losses (i.e., regulatory, permitting, and enforcement) and their impacts on emission inventory compilations. The workshop resulted in suggestions and recommendations for future actions to be taken by the various regulatory bodies represented at the meeting.

John C. Bosch Jr.
Senior Engineer and Program Advisor
Measurement Policy Group
Office of Air Quality Planning and Standards
bosch.john@epa.gov
919-541-5583

Thomas J. Logan
Senior Scientist
Measurement Technology Group
Office of Air Quality Planning and Standards
logan.thomas@epa.gov
919-541-2580

Acknowledgment

We wish to publicly acknowledge the tremendous contribution of our Canadian colleagues to this Workshop: the scientific studies recently undertaken and completed by Environment Canada and the Alberta Research Council provided the basic scientific foundation for the Workshop and without which it could not have been held. Likewise, the numerous European attendees graciously shared their extensive regulatory experience using these new detection technologies with specific emphasis on their applicability to petroleum refineries. ARCADIS, Inc. provided essential scientific leadership and guidance to the Workshop through the welcome participation of Dr. Ram Hashmonay. Last, and certainly not least, our Agency co-sponsor—the Office of Solid Waste and Emergency Response—volunteered their technical insights and necessary administrative and facilitating support for the entire Workshop by their contractor, Environmental Management Support, Inc.

Table of Contents

Notice	i
Preface	ii
Acknowledgment	iii
Table of Contents	v
Acronyms and Abbreviations	vi
Executive Summary	vii
Introduction	1
Organization	1
Presentations	2
<i>The Science of Measurement-Fugitive VOC Emissions</i>	2
<i>Using DIAL to Measure VOC Fugitive Emissions</i>	3
<i>Radial Plume Mapping</i>	6
<i>Infrared Camera Use in the Chemical Industry</i>	7
<i>DIAL Emissions Monitoring in the United Kingdom</i>	9
<i>DIAL Emissions Monitoring in Sweden</i>	11
<i>Ambient VOC Monitoring in Fort Saskatchewan and the Potential Impact of Fugitive VOC Emissions</i>	14
<i>API Critique on the Use of DIAL for Quantifying VOC Emissions</i>	15
Panel Discussions	17
<i>Introduction</i>	17
<i>Panel of Previous Speakers</i>	19
<i>The Problem of Uncounted VOC Emissions</i>	22
<i>Regulatory and Permitting Options and Experiences</i>	25
<i>Forthcoming Studies in the U.S. and Canada</i>	29
Small Group Discussions	30
<i>Monitoring Applicability in the Petroleum Industry</i>	30
<i>Monitoring Applicability in Related Fields</i>	31
<i>Needed Changes to Emission Inventories and Models</i>	33
<i>Legitimizing the New Methods•Rules, Guidance, Work Practices</i>	35
<i>Implementation Issues•Beyond the Rule</i>	36
Action Items	37
Summary	38
Appendix A: Agenda	1
Appendix B: Attendees	1
Appendix C: PowerPoint™ Presentations	1
Appendix D: Outside Resources	1

Acronyms and Abbreviations

a	annually
API	American Petroleum Institute
BTEX	benzene, toluene, ethylbenzene, xylenes
CAFO	confined animal feeding operation
CEMs	continuous emissions monitors
1,2-DCA	1, 2-dichloroethane
DIAL	differential absorption light detection and ranging
EPA	United States Environmental Protection Agency
ETV	Environmental Technology Verification program
FLIR	Forward-looking infrared
FTIR	Fourier transform infrared spectroscopy
GC/MS	gas chromatography/mass spectrometry
H ₂ S	hydrogen sulfide
hr	hour
HRVOC	highly reactive volatile organic compounds
kg	kilogram
LDAR	leak detection and repair
LIDAR	light detection and ranging
NEIC	National Enforcement Investigations Center
NIST	National Institute of Standards and Technology
NPL	National Physical Laboratory
OP-FTIR	Open Path Fourier transform infrared spectroscopy
ppb	parts per billion
PPT	PowerPoint™
QA	quality assurance
SEP	Supplemental environmental project
SIP	state implementation plan
SOF	solar occultation flux method
OP-TDL	Open Path tunable diode laser
ORS	Optical remote sensing
OTM-10	Other Test Method 10
RPM	Radial Plume Mapping
UK	United Kingdom
UV-DOAS	ultraviolet differential optical absorption spectroscopy
VOC	volatile organic compound

Executive Summary

Studies performed in Europe over the past decade, and more recently in Canada, indicate that emissions from refinery and natural gas operations may be 10 to 20 times greater than the amount estimated using standard emission factors. The United States Environmental Protection Agency's (EPA) Office of Air Quality Planning and Standards organized this workshop for the purpose of discussing among regulators the implications of these studies for air quality policy. Attendees included state and local representatives of air quality agencies; EPA regional, headquarters, and laboratory personnel; and Canadian and European air quality experts.

Technology Descriptions

The technologies discussed at the workshop were differential absorption light detection and ranging systems (DIAL), Radial Plume Mapping (RPM) method primarily using open path Fourier transform infrared (OP-FTIR) systems, solar occultation flux (SOF), and infrared sensing video cameras.

The DIAL technique has been used extensively in Europe and more recently in Canada. As currently configured it uses both ultraviolet (UV) and infrared (IR) lasers to measure criteria pollutants (NO_x, SO₂, and O₃) and light aromatic (benzene, toluene, ethylbenzene, and xylene) in the UV, and methane and total hydrocarbon plumes in the IR. DIAL is capable of providing a 2-dimensional contour of concentrations across a scanning plane. By combining this concentration contour with separately obtained wind speeds, a contaminant flux can be calculated. The DIAL system has been validated in European studies for hydrocarbon emissions. Estimated fluxes obtained by the DIAL system are generally assumed to be conservative.

The RPM method is primarily applicable for VOC's losses when using OP-FTIR systems. It can also utilize any path integrated optical remote sensing technique such as ultra violet differential optical absorption spectroscopy (UV-DOAS), open path tunable diode laser absorption spectroscopy (OP-TDLAS), and path-integrated DIAL (diffusely reflected from hard targets) In the OP-FTIR technique a beam of collimated infrared light is sent across the area to be measured and is reflected back to a receiving unit by a mirror (retroreflector). OP-FTIR systems provide an average concentration of chemicals over the distance measured. The advantage of the FTIR is that it speciates as well as quantifies the chemicals in the plume. If the objective of the survey is to locate hotspots or quantify emission rates, a number of retroreflectors are needed at different distances and heights from the sending unit in various RPM configurations. Traditionally FTIR has been used to measure fence-line concentrations at a set height off the ground. This alone (without RPM) may be found very useful for detailed speciation when deploying a DIAL system at a site.

The solar occultation flux (SOF) method is a passive FTIR which relies on an external energy source, the sun. It provides the infrared signatures to speciate and quantitate the

chemicals in a vertical column. The Swedish government has approved the SOF system (method) for whole plant emissions measurements. This system is less accurate than the DIAL system and is subject to climatic constraints (high sun and steady winds). However, experience has shown the same emission levels as the DIAL at comparable measurement points, proving the accuracy of measuring.

Infrared sensing video cameras record the differences in absorption of specific infrared wavelengths in their field of vision. This produces the appearance of a cloud where chemicals are present that absorb at the specified wavelengths. The camera has been very effective in locating large hydrocarbon releases from hard to access places. It does not detect all chemicals, nor does it speciate or quantify them. Releases under 500 ppm are generally not detectable. The camera can be combined with a passive FTIR system that together provide a visual of where the release originated as well as its chemical composition and concentrations.

Findings

The Canadian and European studies indicate that fugitive emissions at petroleum handling (and other) facilities are much higher than would be indicated by emission factor estimates. This is apparently caused by:

- Exclusion of upsets, malfunctions, startups, and shutdowns from the emissions inventory.
- Large VOC emissions that are present from unexpected sources (heat exchangers, process sewers, cooling towers).
- Source areas that are currently excluded from the inventory estimates (e.g., tank roof landings).
- Not using actual tank parameters to estimate emissions and getting information on malfunctions.

An identified problem with emission factor calculations is that they assume all equipment is operating as designed, they do not include some major release areas, and the leak detection and repair (LDAR) programs typically do not measure tanks and difficult to access plant areas. Whole plant measurements can identify problem areas that are not being monitored and allow them to be addressed. Direct measurement of plant emissions is a way to identify areas for improvement, not necessarily a replacement for emission factor estimations. The issue should not be framed in an either/or fashion.

While industry does not question the accuracy of the DIAL measurements, they do question whether values obtained over a several day to several week period can be extrapolated to give an annual emissions estimate. The European members of the workshop thought that there is sufficient evidence from the surveys done in Europe to conclude that extrapolation is appropriate. The general consensus, however, was that a demonstration of the DIAL system that was designed to test representativeness in the U.S. would be needed for U.S. industry acceptance.

Other problems raised at the workshop involving emissions include:

- Several studies indicate that facilities using emission factor calculations can show that their emission rates are going down, but actual measurement of releases at these facilities does not support a release reduction.
- When the wind speed is greater than five miles per hour, flare efficiency drops significantly. The emission factor for flare estimation is based on a flare operating in still air conditions, hence it is likely to understate actual releases.

Recommendations

After considering the information presented at the workshop, the following major recommendations were made by the attendees:

- The magnitude of the underestimation of emissions, their composition and potential health impacts, and the geographical areas where they are occurring should be brought to the attention of top management in policy offices.
- A methodology for using the infrared camera that includes its limitations should be developed and included in OTM-10.
- EPA should take the lead in developing a policy on how to address the understating of emissions so that the regulatory community can speak with one voice. It will be difficult, if not impossible, for a local or state entity to try to compel industry to conduct these measurements when it is not being done elsewhere or advocated by EPA.
- EPA should be more emphatic on the position that emission factors are not the best practice and that measuring is the preferred method to determine emissions.
- A demonstration of the DIAL technique together with other open path technologies should be undertaken in the U.S. This demonstration should include the development of protocols, including strict QA/QC measures, for the equipment use and should at a minimum be sufficient to determine the chemical composition of the emissions and show that the measurements taken are representative of plant emissions in general.
- EPA should take advantage of the DIAL system being brought from the UK for the Houston Ship Channel test by actively supporting it and by finding other demonstration opportunities through mechanisms, such as the ETV or ESTCP programs.
- If the demonstrations prove successful, the EPA should find access to a DIAL system for auditing purposes.

Introduction

Studies performed in Europe over the past decade and more recently in Canada indicate that emissions from refinery and natural gas operations may be 10 to 20 times greater than the amount estimated using current standard emission factors. As a result, the U.S. Environmental Protection Agency's Office of Air Quality Planning and Standards and Office of Solid Waste and Emergency Response sponsored a workshop with Environment Canada to discuss the methodologies the Europeans and Canadians have used to monitor fugitive volatile organic compound (VOC) emissions particularly from petroleum exploration, refining, and retailing operations. Representatives from Environment Canada, Sweden, United Kingdom (UK), EPA, and state and local agencies attended the workshop. [Appendix B](#) contains a list of the attendees.

The Canadians and Europeans applied optical remote sensing (ORS) technologies to conduct plant-wide, real time monitoring of the fugitive emissions. The primary instrument they used is a differential absorption light (DIAL) detection and ranging system that is capable of profiling hydrocarbon concentrations. When combined with meteorological data, it also can measure contaminant flux. Open path Fourier transform infrared (OP-FTIR) spectroscopy and infrared imaging cameras also were applied as tools to further aid in detecting and controlling fugitive emissions.

Organization

This workshop summary is organized into five main sections. The first section summarizes eight technical presentations made by invited speakers. [Appendix C](#) contains the speakers Powerpoint™ presentations.

The panel discussion section has an introductory presentation by Dan Powell, Chief, of EPA's Technology Integration and Information Branch (TIIB), Office of Superfund Remediation & Technology Innovation. This presentation is followed by four panel discussions with a question and answer session following each panel.

The last section summarizes the findings of five breakout groups. Each group was given a topic of concern and asked to relate it to information presented during the course of the workshop. They were asked to report on any barriers to conveying the information or implementing programs, suggest ways of overcoming these barriers, and draw up a set of recommendations for each topic of concern. At the conclusion of the breakout group presentations, John Bosch, Measurement Policy Group, Office of Air Quality Planning and Standards, presented a list of Action Items.

The final summary section includes findings, needs, and recommendations.

[Appendix D](#) is meant to be a resource center for workshop attendees. It contains:

- An overview URL section that has a basic description of all the open path technologies and a searchable database of over 600 abstracts on various open path subjects.
- A case studies section that provides a wide range of examples where open path technologies have been deployed and each case study is hyperlinked to its complete article for further information.
- An Environmental Technology Verification Program section that contains links to EPA performance reports on various open path vendor equipment.
- A guidance section that has both EPA and European documents on the use of open path equipment.
- A vendor section contains contact information for the three vendors, who were involved in the Canadian and Swedish studies and the vendor providing RPM services..

Presentations

The speakers described the science behind optical remote sensing, and used case studies to illustrate how the techniques can be used. The case studies also illustrated some of the issues that arise when whole site emissions are monitored. They also provided a basis for later discussions in the workshop.

The Science of Measurement Fugitive VOC Emissions

Dr. Ram Hashmonay, ARCADIS

With the passage of the Clean Air Act amendments in 1990, optical remote sensing (ORS) technologies have been seen as promising techniques for air emissions monitoring. These technologies can measure the average concentration of a contaminant(s) over a defined distance at a point in time (e.g., OP-FTIR) or specific concentrations at specified distances at a point in time (e.g., DIAL). When combined with meteorological data (e.g., wind speed) they can provide estimates of flux or the emission rates of contaminants from multiple sources over the distance being measured.

The most primitive method of measuring fugitive emissions involves the use of canisters that collect air at a point in space over a given time frame (generally 24 hours). This method, a case study of which is given by [Curtis Englot](#), provides an average concentration at the intake point of the canister. It suffers from the fact that the contaminant plume may not cross at the location of the sampler at all or for any length of time.

Traditional OP-FTIR measurements help solve this problem by averaging the plume concentrations over a long path, typically a half kilometer or less with an active system. Wind speed measurements and inverse dispersion modeling can be combined with

these concentrations to give an average flux across the line of sight. This system cannot locate sources (hotspots in the plume) nor can it capture the vertical extent of the plume.

Radial plume mapping, an example of which is given by [Bruce Harris](#), improves on the traditional method by providing a series of retroreflectors along a line of sight as well as at different heights. This deployment allows for comparing the average concentration found in a plume among segments to aid in locating hotspots and for constructing a vertical plane to provide a 2-dimensional concentration average. Combining this average with wind speeds gives an estimate of flux leaving a site through the defined vertical plane. Doppler radar can also be used to obtain a better measurement of wind velocity and direction. (See EPA [2004](#), [2005a](#), [2005b](#), and [Varma et al. 2005](#))

DIAL, which is discussed in presentations by [Allan Chambers](#), [Lennart Frisch](#), and [Rod Robinson](#), provides the best means for locating hotspots within a plume and calculating total contaminant flux leaving a facility. It does not depend upon retroreflectors to return the laser beam and is gated to allow for quantitative measurements at any set distance from the instrument. It is capable of supplying 3-dimensional estimates of contaminant concentrations; however, unlike FTIR, it is not capable of specifically identifying multiple contaminants with one pass. It can identify single contaminants or classes of contaminants that have common absorption frequencies.

The infrared camera, also discussed by [David Williams](#), is capable of imaging hydrocarbon plumes as they leave a source (e.g., tank, valve, pump), but it is not capable of quantifying a leak or calculating a flux. The detection limits of the camera are in the 100s of ppm. Due to the narrow frequency filter in current models, the camera can be blind to some emissions.

Other Test Method 10 (OTM 10)—Optical Remote Sensing for Emission Characterization from Non-Point Sources (<http://www.epa.gov/ttn/emc/prelim/otm10.pdf>) is an EPA protocol for radial plume mapping using open path technologies. It is not specific to any instrumentation but provides a methodology for conducting the flux measurements survey.

Click [here](#) for a pdf file of this PowerPoint™ (PPT) presentation.

Using DIAL to Measure VOC Fugitive Emissions

Allan Chambers, Alberta Research Council, Inc.

With funding from Environment Canada, private industry, Ontario Ministry of Environment and Alberta Environment, the Alberta Research Council conducted several studies with a DIAL system (Spectrasyne, Ltd.) and an infrared imaging camera (Leak Surveys, Inc.). The results of the DIAL measurements were compared with standard industry emission factors calculations. To view studies, see [Chambers](#) in [Appendix C: Other Resources](#).

The studies covered two sweet and four sour gas processing plants, a refinery, a tar sands mining and separation facility, and a bitumen upgrader. The DIAL measurements were performed by Spectrasyne Ltd., UK, using their DIAL system. The DIAL system comprised two DIAL lasers—one in the infrared range and one in the ultraviolet range, with a self-contained weather station for measuring wind speed and temperature. With this system, total contaminant flux can be calculated and portions of the plume assigned to specific sources. The system has been validated in European studies for hydrocarbon emissions with calculated results ranging from ± 3 to ± 12 percent of the actual value. Two validation studies were performed in Alberta with measured fluxes agreeing within +1 to -10% of the known source.

At the gas processing plants, fugitive emissions of methane ranged from 77 to 146 kg/hr and C_{2+} (ethane and higher) ranged from 41 to 342 kg/hr. The areas contributing the most to the fugitive emissions at one of the sites were the compressors and condensate tanks. Process flares contribute about 10 to 15 percent of methane emissions. Having this type of information allows plant operators to maximize their return on maintenance operations.

At the refinery survey, approximately 1,237 kg/hr of C_{2+} were being released with major contributors being the coker plus vacuum unit (17 percent), the product tanks (22 percent), and the cooling towers (13 percent). The cooling tower numbers were a surprise to the facility as they do not have them in their total emissions calculations. Also, there was a relatively new process area and an old process area. The new area had 5.5 percent of the emission total while the old area contributed 13 percent.

About 300 kg/hr of methane were being released at the refinery with the main source being the coker vacuum unit (125 kg/hr). Benzene measurements showed that about 5 kg/hr were being released with the main source areas being the coker vacuum unit and product tanks.

The calculated annual emissions rate of C_{2+} hydrocarbons for this refinery was 9,970 tons/yr. This rate, which is based on 10 days of DIAL measurements, assumes that C_{2+} values represent total VOC emissions during a 48 week operation. This value is considerably higher than the refinery estimate of 670.4 tons/yr that used the American Petroleum Institute (API) emission factors method. The study also found that tanks made up a much larger portion of the emissions than estimates would suggest. From other studies of refineries done by Spectrasyne, it would appear that the actual process area of the refinery contributes a smaller percentage of total emissions than API estimation methods suggest.

The refinery study also used an infrared camera to image releases. The camera was able to identify large releases but not to quantify them. At one gas processing facility the camera was used to identify 33 leaks. DIAL measurements made in 2003 at the initial leak identification time and in 2004 after many of the leaks had been repaired indicate that the plant had reduced releases of C_{2+} by over 90 percent. This shows that there is a potential to recover significant dollars when leaks can be identified.

Click [here](#) for a pdf file of this PPT presentation.

QUESTIONS AND ANSWERS

Question. Did you compare the DIAL measurements with emission factors calculated at the time of those measurements?

Answer. The measurements were compared with emission factor calculations submitted by the facility for the previous year.

Question. Were the gas processing leaks found with the camera and then quantified with the DIAL?

Answer. The DIAL can be used for locating larger leaks as well as quantifying them. At the gas plant the total emission flux was measured with the DIAL first and then the camera was used to help with specific sources. The camera on the return visit indicated that many of the releases had been stopped and the DIAL measurement of a reduced total flux verified this. The camera is excellent for identifying relatively large leaks.

Question. Were the releases quantified before they were fixed to see if they met the definition of a leaker?

Answer. No. The one problem with the camera is it does not quantify release rates. Other equipment (such as a sniffer) could have been used to estimate rates of individual leaks but the project did not have the budget to do so.

Question. Is there any potential solution to the coker unit emissions problem?

Answer. The refinery is replacing the coker unit as part of an upgrade and this may reduce emissions. Measurements were made both when the coke was being drilled (after full water quench) and when it was not. Emissions were higher when the coke was being drilled and dumped. At this site, the dumping was directly into rail cars.

Comment. Texas has a number of coker units that are currently not in the inventory.

Question. How do you quantify leaks like those shown in the movie?

Answer. If the leak is large it can be quantified with the DIAL. This is done by progressively scanning closer to the source; however, the DIAL is a very expensive way to quantify individual leaks.

Comment: Open path FTIR in RPM configuration can be used for quantifying smaller leaks in a cost effective way. The best way to use these methods is together; use one to quantify total emissions and the other to find individual leaks.

Question. Because the DIAL only measures concentration, how do you quantify total emissions with it?

Answer. The DIAL gives a 2-dimensional concentration profile through the plume. By assigning a density to the plume contaminants and multiplying by a wind speed, flux can be determined. To provide an accurate density, the plume area is often sampled and a detailed analysis of its composition is made by separate techniques.

Radial Plume Mapping

Bruce Harris, Office of Research and Development, EPA

Radial plume mapping can be applied to any open path survey technique. OP-FTIR is frequently used because it can identify and quantify many compounds simultaneously, has relatively good detection limits (parts per billion (ppb)), and can also detect particulate matter. Tunable diode lasers are a relatively recent development and have become available in many forms due to investment by the communications industry. They generally detect only one compound at a time and use near infrared radiation. UV-DOAS uses ultraviolet light to detect such chemicals as hydrogen sulfide, mercury, and aromatics such as benzene, toluene, ethylbenzene, and xylenes (BTEX). DIAL operation has been mentioned before and has an advantage over other techniques because of its long range and concentration mapping capabilities.

In radial plume mapping the instrument is set up to send light to various retroreflectors that are deployed perpendicular to and at different horizontal distances across the plume path. Retroreflectors mounted vertically and horizontally (vertical radial plume mapping (VRPM)) allow for a 2-dimensional calculation of contaminant concentrations. Wind speed can be used with these concentration values to obtain an average flux.

In monitoring mercury flux from a facility, an onsite water tower was used to mount radiation sources for three UV-DOAS instruments that made simultaneous measurements at three different heights.

Combining instrumentation such as lidar technology and VRPM with OP-FTIR can prove valuable. For example, in a situation where a plume containing fugitive dust is of interest, two OP-FTIR systems (in VRPM configurations) along with two visibleransmissometer were used to identify chemical content of the dust and PM10/PM2.5 concentration. A micropulse LIDAR can map the particulate plume in much larger scale. Similarly, for gases a combination of OP-FTIR in VRPM configuration and DIAL may provide the ultimate required data for emission measurement for a refinery.

When looking for near ground releases, such as those found at landfills, horizontal plume mapping can be used to locate hotspots. In this sampling strategy, the site is gridded and retroreflectors placed within the grid squares. An ORS unit measures the average concentration between it and the retroreflectors, and high concentration areas

can be identified. The high areas are then subdivided and the process repeated until the hotspot is located.

In summary:

- ORS can be used to detect fugitive emissions such as process leaks.
- The methodology of choice depends on the target compound(s) and source range.
- A combination of methodologies may provide the most complete information.

Click [here](#) for a pdf file of this PPT presentation.

QUESTION AND ANSWER

Question. What does a survey of this type cost?

Answer. Capital costs of the scanning TDL equipment are on the order of \$40,000-\$50,000 and the FTIR is \$100,000 or more. The cost of doing a week-long study, including quality assurance (QA), and report is on the order of \$50,000. Long-term (year or more) FTIR fence-line monitoring costs around \$250,000. If sites are in the same general area, the cost per site should be less.

Comment. One reason for higher costs is that the market for the equipment is small. If more people use these techniques for monitoring the costs quoted above should come down. The relative cost of tunable diode lasers (TDLs), which have a very large market other than environmental, have shown this trend.

Infrared Camera Use in the Chemical Industry

David Williams, Office of Research and Development, EPA

The goal of monitoring at refineries and chemical plants, which will have fugitive emissions, is to reduce leaks to a level as low as possible. This is generally accomplished with a Leak Detection and Repair (LDAR) program. Typically, these programs rely on the use of an organic vapor analyzer (flame ionization detector) to check each component, which is time consuming and costly. In addition, some points in a plant are difficult if not impossible to get close enough to with the hand-held wand to obtain a measurement.

Hand held thermal imaging cameras can rapidly scan for leaks; however, the detection limits and sensitivity of the cameras are not well known. A release may be detected under one set of conditions but missed under a different set of conditions. These changing conditions include air background, gas temperatures, and humidity. The cameras can be mounted on aircraft from which they can provide a rapid scanning of releases from a plant site.

The camera operates in a passive mode, which means that it depends on an outside entity to provide radiation. As the radiation passes through a chemical plume, certain

frequencies are absorbed. If the absorbed frequencies fall within the camera's narrow mid-infrared bandwidth, they appear as a dark spot or cloud on the video. If the absorbed frequencies do not fall within the camera's bandwidth, then the plume will be invisible to it.

The GasfindIR camera (FLIR Systems, Wilsonville, OR, USA) is a thermally cooled monochromatic video camera with a spectral filter. Although the camera collects a broad range of frequencies, the filter only samples a narrow range common to specific chemicals such as propane and octane. It does not quantify or speciate the chemicals within the plume so it cannot be used to estimate flux.

To obtain more information, a hybrid system that combines the video camera with a passive FTIR spectrometer can be used to locate, speciate, quantify, and determine flux rate. The video camera provides wind direction and speed while the spectrometer identifies the chemicals present and their concentration.

The camera is rapidly being adopted by industry, and a new alternative work practice for leak detection is being finalized. EPA is planning an Environmental Technology Verification Program (ETV) project that will test the performance of several technologies (including the infrared camera) for leak detection against a set of measures from lab experiments and from several plant sites.

Members of the audience who are potential stakeholders in this project were invited to submit to EPA a list of the kinds of information they need the technologies to give them.

Click [here](#) for pdf file of this PPT presentation.

QUESTION AND ANSWER

Question. Have you evaluated manual versus automatic settings for the camera? It is possible in some settings to make a plume appear or disappear by changing from one to the other.

Answer. No evaluation of manual versus automatic settings has been done by EPA. Polarity can also cause misinterpretation of whether a hydrocarbon plume exists or not.

Question. For Mr. Chambers: Do you have any idea why your measurements were so much higher than those obtained with the API methodology?

Answer. The measurements showed that releases from the tanks were much larger than anticipated, but other than that, it is probably because the API methods are very conservative. A host of things can happen at a large complex refinery to invalidate assumptions made on releases for equipment functioning as designed.

Question. To what degree are Louisiana, Texas, Tennessee, and Arkansas incorporating this equipment into regulatory requirements like surveys and audits?

Answer. Tennessee does not have a camera. Louisiana has a camera and uses it on inspections, but it is not part of their regulations. They are waiting to see what the EPA alternative work practice will say. Texas has not incorporated the camera into their regulations but they have used the camera to identify practices, such as landing tank roofs, or problem areas, such as in the oil and gas fields where condensate tanks tend to have a lot of releases. Texas is developing regulations for these areas to improve work practices that reduce these emissions.

Question. Is the scanning FTIR commercially available?

Answer. Yes. The system that will be demonstrated during the break has a video camera and scanning FTIR plus accessories and costs about \$300,000. Like the video camera, the passive FTIR is also temperature dependent; however, it does collect full spectrum information and is orders of magnitude more sensitive than the camera.

DIAL Emissions Monitoring in the United Kingdom

Rod Robinson, National Physical Laboratory, UK

The National Physical Laboratory (NPL) is the UK version of the U.S. National Institute of Standards and Technology (NIST).

Conventional techniques (e.g., wand, canister) collect or measure concentrations of chemicals at a point in space. Open path technologies quantitate and/or speciate chemicals over a distance. Technologies, such as FTIR and UV-DOAS, provide an average concentration over a defined area. They can operate in the active mode (supply their own light) or in a passive mode (rely on an outside source of energy). Active systems can be single or double ended. In the double mode, the transmitting and receiving instruments are co-located, and the light is sent through the target area and bounced back to the receiving unit using a retroreflector. In the single mode the transmitting unit is placed on one side of the target and the receiving unit is stationed on the other. These instruments are capable of speciating a number of chemicals at one time.

The DIAL technology provides a range resolved result where light is transmitted into the target area and reflected light is measured. The time of flight allows the instrument to calculate the distance to the reflection point and hence provide a 2-dimensional concentration contour. The DIAL system is targeted to one or two species at a time. It can be used to estimate VOC concentration in general by targeting a generic wavelength that is representative of the carbon-hydrogen bond in the species. This generic measurement will yield information on the C₂ to C₈ compounds. The NPL-

developed system uses both infrared and ultraviolet light. A high resolution flux measurement can be made in less than 10 minutes.

The NPL developed the source and detection systems for the infrared DIAL in the mid to late 1980s. A joint project with British Petroleum commercialized the system in the late 1980s and spun off Spectrasyne Ltd. to provide the service and equipment. Spetrasyne provided the system used recently in Canada.

The infrared DIAL is used primarily for alkanes although it can identify and quantitate most species with absorption in the infrared spectral region between 2.5 to 4 microns – including, for example, hydrogen chloride, nitrous oxide, and methanol. Detection limits for the alkanes are in the 10 to 50 ppb range at distances up to about 800 meters. The UV/Visible DIAL can identify and speciate benzene, toluene, and xylenes in the 10 to 20 ppb range and is also used for elemental mercury, ozone, sulfur dioxide, nitrogen dioxide, and nitrogen monoxide. Detection limits are very dependent upon site conditions at the time of measurement.

During an NPL verification project, the DIAL measurements for a known methane release were within ± 10 percent of the true values. In other experiments, the DIAL measurements were within ± 12 percent of the true value of an aliphatic hydrocarbon plume and within ± 15 percent of a toluene plume. Wind speed measurements, used to calculate the flux, are responsible for a significant part of the error.

The DIAL system has been used to:

- Quantify and calculate flux emissions from multiple sources within a complex plant.
- Identify and quantitate fugitive emissions to locate leaks.
- Calculate flare burner efficiencies.
- Conduct compliance monitoring including fence-line surveys.
- Track the fate of plumes from a plant.

Examples of these applications are given in the accompanying PPT presentation

In general, the estimated emissions for a facility are lower than the DIAL measurements. This is often due to the facility not including sources in their inventory calculations or from malfunctioning equipment that is not normally monitored. In most cases at industrial plants we have observed sources of emission that were not expected by the site staff.

Click [here](#) for pdf file of this PPT presentation.

QUESTIONS AND ANSWERS

Question. The flares you were looking at were they engineered or straight pipe?

Answer. Generally they are process flares used on rare occasions, not continuously operated ones. Mostly the flares monitored were engineered, though not steam injection

Question. When plume tracking projects are performed, is a background established to ensure what is tracked is site related?

Answer. Since the instrument can scan in both the horizontal and vertical, measurement locations can be chosen to allow measurements upstream and downstream of the source, this enables upstream sources to be identified and removed if necessary.

Question. What is the cost of operating the system?

Answer. It is a two person operation. Sometimes a third person is used to take measurements and collect samples other than those for DIAL. Plan a week for data collection and a week for processing.

DIAL Emissions Monitoring in Sweden

Lennart Frisch, Agenda Enviro AB, Sweden

In the mid-1980s, mass balance data indicated losses at the refineries, but they were a small part of total throughput. The facilities at the time were against doing any kind of measurements; however, due to the refineries' location in a major urban center, the public indicated some concern. All emissions information in Sweden is in the public domain, which tends to focus public attention on facilities.

The provincial government asked the best located refinery (topographical and upwind from other sources) to perform the measurements or face a \$300,000 fine. The actual measurements indicated that the emphasis on controlling process emissions was missing other major sources of releases, such as tank storage. Another issue was that emissions from products heavier than kerosene were set at zero, when in fact they may contain light ends. At a plant working with heavy-end products, the feedstock was stored at elevated temperatures. The plant had set the emissions from these storage areas at zero, but serious releases were occurring. Also, high unexpected emission levels have been recorded for single process area leaks (mounting to some 4,000 tons/a, tanks with ruptured outer seals, and underground cavern storage facilities (800 tons/a) amongst others .

The original measurements were directed at the C₃ to C₈ alkane hydrocarbons; however, it is also important to measure C₂ and C₉ through C₁₅ alkane hydrocarbons and BTEX because they make up a large portion of emissions. In Sweden, whole plant measurements generally have been done every three years, starting in 1988.

Frequencies today, however, are reconsidered and site-adjusted, and more repeated measurements focusing on hot spots are considered as more knowledge and experience now exists concerning the overall picture. The measurement results indicate that each tank behaves differently and should be treated differently. Also, emissions vary by how full the tank is. Measurements over time indicate that 15 to 40 percent of emissions are from process areas, 40 to 80 percent are from tanks, and 5 to 10 percent are from wastewater treatment areas. The wastewater treatment areas can be higher if there is a large open surface.

The measurement results, taken over time under different climatic and operating conditions, always tend to be considerably higher than emission factor calculations. Typically, measurements did show some 10 to 20 times higher emissions than calculated at initial measurement activities, when prior knowledge had been missing on the plants on where and how to actually combat the emissions. Today, after long term experience with the measurements and also after successful improvements of plant operations regarding emissions, emission levels of some 3 to 10 times higher than what is theoretically calculated are typically seen. Given this trend and the number of surveys that have been done, there is an indisputable statistical basis for using the DIAL measurement for calculating annual emissions. In addition, unless the actual aim of the measurement campaign is to capture these emissions, DIAL measurements are not carried out at times when non-stable plant operations can be foreseen producing emissions, such as plant start up or shutdown, tank cleanout, or optimal fill level for tank emissions. DIAL measurements generally do not capture 100 percent of the plume due to meteorological reasons. Since these factors produce higher numbers, DIAL is more likely to underestimate emissions than overestimate them.

The problem with emission factor calculations is that they assume all equipment is operating as designed, they do not include some major release areas, and the LDAR programs typically do not properly include tanks and difficult to access plant areas. Whole plant measurements will identify problem areas that are not being monitored and allow them to be addressed. In many instances, they allow for more efficient allocation of maintenance efforts by targeting the worst first.

In recent years, another measurement technique also has been developed in Sweden which now, largely due to its Swedish origin, is favored by the Swedish authorities. Called the solar occultation flux method (SOF), it uses a passive FTIR system mounted in a truck. It can measure olefins and alkanes but not aromatics. Also some restrictions seem to exist on the range of hydrocarbons measured, i.e. for those heavier than some C_8 to C_{10} . Its use is limited to sunny days, and the wind must be in the same direction for a longer period of time. It is important to note, while each approach is different, the DIAL and SOF systems both produce roughly equivalent emissions data, which provides further proof that the measurements give true results.

The Swedish study on emissions development and measurement methodology can be found at [Frisch 2003](#).

Click [here](#) for pdf file of this PPT presentation.

QUESTION AND ANSWERS

Question. There was a slide that showed a comparison between the DIAL measurements versus the calculated ones and that emissions were greatly reduced from 1988 to 1999. What specifically was done at the site to obtain these reductions?

Answer. A number of things. The leak detection program was increased. They changed equipment. They treated each tank separately and replaced some seals. (For a list of specific changes at specific facilities see [Frisch 2003](#).)

Comment. Agree that each tank behaves differently and should be addressed separately. The emission factors do not capture how each tank physically operates and this causes a gap in the values measured versus those calculated.

Comment. Even if you get more emission factors for tanks, they won't tell you anything about the individual tank. The [CONCAWE](#) study done in 1995 that Mr. [Ferry](#) refers to comparisons of DIAL and emission factor estimates on well maintained and comparably small tanks, which is mainly why they compared favorably. The DIAL measurement gives total emissions and while it is a point in time measurement, all of the studies indicate the same conclusion, that emissions factor estimates are greatly understating total emissions. If this was not the case, one would expect that at least one of the DIAL studies would show comparable or less emissions than the emission factor estimates, but they do not.

Comment. One very apparent fact is a development in emissions data which can be shown for the refinery where the most long time statistics on measurements exist, the Preemraff in Gothenburg, Sweden (formerly BP and OK). Whereas measurements show that VOC-emissions have been reduced by some 80–90% from 1988 until today, the traditional theoretical calculation methods give higher emissions. The reason for the latter is that the calculations do not in a proper way include when better performing equipment is used and is also to a large extent related to the number of potentially leaking equipment, i.e. an expansion of the site always will result in “theoretically” higher emissions. Also the calculations focus on process area emission, and by doing so miss to a large extent development and emissions related to storage tanks and WWT-facilities.

Comment. It is very important that any DIAL or SOF measurement be combined with sufficient meteorological equipment and with devices that can measure the actual distribution of hydrocarbons at the spots measured. The devices have to be able to speciate the aromatics and the heavier hydrocarbons (up to some C₁₅) as presented in the presentation figures otherwise the calculated flux will be lower than the actual true emission levels.

Ambient VOC Monitoring in Fort Saskatchewan and the Potential Impact of Fugitive VOC Emissions

Curtis Englot, Environment Canada

A VOC monitoring study was conducted in the Fort Saskatchewan, Alberta area from September 2004 to March 2006. Edmonton and the surrounding area has about one million people and lies to the southwest. There are a number of chemical plants and refineries in the immediate area, as well as coal-fired power plants on the east end of the city. In spite of the industrial activity, Fort Saskatchewan itself is a small city located in a relatively rural setting.

Six stationary sampling points were set up as part of the sampling system with one being located in the valley and one in a national park to the southeast. Twenty-four hour samples were taken every six days with summa canisters and analyzed by GC/MS for a suite of 150 VOCs. In total, there were 95 sampling days with a total of 537 canisters.

Total VOC values decreased in the summer months. Inversion effects occurred in the winter. During 10 sampling events 1,2-dichloroethane (1,2-DCA) concentrations exceeded health standards. Because of a lack of health standards for the 150 chemicals, the concentrations were compared with the group average of six other urban areas. Eight VOCs exceeded these averages including, 1,2-DCA and vinyl chloride. Of the eight chemical exceedances four were affected by unique events.

The only facility located in Canada that manufactures 1,2-DCA is in Fort Saskatchewan. In 2001 this facility undertook emission reduction activities under an Environmental Performance Agreement. The Agreement required fence-line monitoring, which was expected to show low concentrations. The 1,2-DCA concentrations were higher than expected, and a more detailed monitoring system focusing on receptors was required. Emission factor calculations showed that facility emission rates were going down, but this was not supported by the ambient data.

Data from the canister study showed high concentrations at several sampling points on a few specific days. Examination of facility records indicated that their processes were working as expected during those times (i.e., no known upset or unusual situations). The potential release was modeled with a Lagrangian Stochastic MLCD model by the Canadian Meteorological Centre. The model allows the back calculation of the concentration found at the monitoring station to determine what the emission rate at the source would have to be to produce the concentration. The model also shows plume variation over a 24-hour period. As can be seen with the model, the stationary monitoring points are rarely in the path of the plume for any length of time and hence are not representative of actual emissions. To illustrate this further, monitoring was occurring at a time when there was a significant benzene spill. The plant reported the spill but subsequent analysis of the canisters was negative. An analysis of meteorological data for the time period in question indicated the sampling points were not in a position to capture any part of the benzene plume.

A back calculation of the data indicated about 100 kg/hr of 1,2-DCA emissions. The plant ran a model of their own and it too indicated a 100 kg/hr emission rate, but the source was unknown. An evaluation of the plant as a whole indicated that a large number of unmonitored components at the facility may be contributing to this emission rate. For example, there are approximately 26,000 connectors at the plant, and 67.5 percent of them are not monitored (primarily due to access issues). Emissions from these approximately 17,000 unmonitored points are calculated using an average for the monitored points. Also two-thirds of the valves at the plant are not monitored. Their emissions are calculated by the average of the ones that are monitored. In addition, an inspection of the facility's storage tanks revealed that one lacked a seal.

In conclusion, measured ambient monitoring data indicated emissions were higher than calculated values and that routine activities may have bigger impacts than expected. Published reports on the study are at http://www.fortair.org/airquality_reports.php.

Click [here](#) for pdf file of this PPT presentation.

QUESTIONS AND ANSWERS

Question. Are compressors used in the manufacturing process?

Answer. Yes.

Comment. In ethylene production at a plant in Texas the compressor crankcases were major sources of fugitive emissions.

Question. Why would you care about monitoring the insulated components?

Answer. The insulation, which is fiberglass with a foil covering, will have little impact on mitigating leaks.

API Critique on the Use of DIAL for Quantifying VOC Emissions

Rob Ferry, API Consultant

Rob Ferry stated that his views do not necessarily represent those of API.

The greater the variation in actual emissions, the greater the potential uncertainty in an emissions estimate that does not account for this variation. For example, in AP-42 the emission factor for the loading of a shallow draft barge with crude oil is 1.0 lb per 1,000 gallons. This is a fixed value emission factor in that it relates to the single parameter of throughput. It does not account for variation in vapor pressure, temperature, or loading method, among other things. Yet these factors can influence emission rate.

The AP-42 general loading equation can also be used to calculate emissions. The equation requires knowledge of the liquid's true vapor pressure, saturation factor, molecular weight of the vapors, and the temperature of the liquid being loaded. Vapor pressures can be estimated for product type, but vapor pressures can vary widely with

crude oil even when keeping temperature constant. The saturation factor is a function of the prior condition of the compartment and the manner in which loading is conducted.

Fixed value emission factors can have large uncertainties with the actual value ranging over orders of magnitude. The fixed value represented by the emission factor lies at some point in this range. A similar limitation holds true for estimating long-term average emissions from point in time measurements. These measurements can be very accurate, but they represent the emissions occurring for some combination of conditions at the time of measurement.

The API objection to the Canadian reports is not that the DIAL measurements are incorrect, but that they were taken over an inadequate time period to allow them to be used for calculating a yearly emissions number.

Typically, unaccounted for or overlooked emissions have been thought of as non-routine or insignificant and the government efforts have been focused on tightening up normal operations. State and local authorities in non-attainment areas are taking the lead in looking at the unaccounted for or overlooked emissions because they need to find ways other than just following the standard federal requirements to reduce emissions. Remote sensing devices can play a role in this.

In the Houston Ship Channel the state of Texas has found that there are 1,000s of tons of unaccounted for emissions from floating roof landing losses. Tank emission factor estimates assume the floating tank roof is always floating hence do not contain landing losses. Imaging devices have shown the potential for significant losses at cooling towers. Cooling towers have a fixed value emission factor that may not be correct. Several refineries in Texas now have continuous monitoring of cooling tower emissions to determine their true value.

In using remote sensing, the question "what is the goal of the test" should be asked. If the goal is to locate unaccounted for hotspots, then a test for a limited time would be appropriate. If the goal is to check or set new emission factors then there should be sufficient testing to provide representative data points over a longer period of time.

Click [here](#) for pdf file of this PPT presentation.

QUESTIONS AND ANSWERS

Comment. Agree with the point that measurements for a short time on a system with inherent variability may be not fair, but the same criticism applies to emission factors.

Comment. There are about 50 factors that can be changed on calculating emissions from a tank and often these calculations are incorrectly done.

Question.	Is API or EPA working on getting a better temporal relationship of emissions versus the average? Right now the tank equations are a monthly average, which is not particularly helpful in getting an area into attainment.
Answer.	No. The need is understood that in non-attainment areas hourly rates are used, but doing the calculations for a shorter time would be a massive undertaking.
Question.	How well are the factors being applied in actual practice, especially with tanks?
Answer.	The application varies greatly. It depends upon the diligence of the operator and how closely the regulator is watching.

Panel Discussions

Introduction

Dan Powell, Chief, Technology Integration and Information Branch (TIIB), Office of Superfund Remediation & Technology Innovation, EPA.

TIIB co-sponsored this workshop because there is an overlapping interest between the Air Office and Superfund in the technologies being presented. TIIB is part of the innovative technology program (formerly the Technology Innovation Office) whose mission is to identify and advocate innovative technologies for cleanup, characterization, monitoring, and data management activities. By creating an overarching "infrastructure" for identification and transfer of technologies and approaches, the office seeks to change the behavior of project managers in the field (EPA, industry, and consultants).

The waste programs tend to have a different approach than the air programs in that they rely more on guidance than regulation, and in many cases, the program itself is doing the investigation, so there is a concern about the legal defensibility of the data collected. In addition, there is a growing emphasis on site reuse and the placing of buildings on land that will have residual contamination, or in the case of landfills, contamination left in place after cleanup. Waste program monitoring needs include remediation performance, fence line monitoring during cleanup activities, hot spot identification, indoor air vapor intrusion, and fugitive emissions impacts on land reuse. There is room for improvement of the technologies currently used to do these things.

With budget tightening, it is crucial that EPA programs maintain a dialogue on technical capabilities to enable leveraging of funds spent. The waste program focus is on hardware (sampling, analytical, and data management) and on strategies (Triad). The overall perception of site cleanup is that it takes too long and costs too much. Unfortunately, experience has shown that this is often the case and in many instances it is due to poor or inadequate site characterization. The Triad approach, which is a major initiative of the office, is a strategy to improve the understanding of site conditions while

reducing the cost of obtaining site information. Triad consists of systematic planning to identify data gaps and reduce uncertainty, a dynamic work strategy that allow decisions to be made in the field on what to do next, and real or near real time measurement technologies to support the decisions.

The Technology Innovation Program (TIP) has established the Measurement and Monitoring Technologies for the 21st Century Initiative. This initiative was established to ensure continued development and application of measurement and monitoring capabilities for needs identified by the Office of Solid Waste and Emergency Response (OSWER). There is "seed" money available to the regions for testing new technologies at their sites and this money (in the past, this has been about \$400 K) is made available through a project solicitation process each year. TIP also has input into the Agency's small business innovation research (SBIR) program to ensure that some of the SBIR funding addresses identified OSWER needs.

Air-related areas that the program has identified for research and development efforts include:

- Air Emissions Monitoring.
 - Continuous emissions monitors (CEMs) for use with thermal hazardous waste treatment systems.
 - Remote sensing for fence-line monitoring for fugitive emissions/enforcement activities.
 - Emergency response.
- Indoor Air Quality–Monitoring vapor intrusion into buildings.
- In Situ Monitoring Systems.

With these commonalities we need to establish cross program dialogues to ensure that we are pooling our expertise and efforts. The SBIR program also presents a funding opportunity for seeing that our common needs are addressed. We have outreach tools that are currently available. The Cleanup Information (CLU-IN) Website (<http://www.cluin.org>) contains a large amount of information on a variety of different topics related to remediation, characterization, and monitoring. The CLU-IN website offers a mechanism for training seminars on a variety of topics. It would be relatively easy to offer a CLU-IN Internet seminar related to open path technologies or monitoring refineries.

Click [here](#) for pdf file of this PPT presentation.

The Monitoring and Measurement Initiative webpage contains an open path focus section that discusses the various open path technologies, their applications, and potential uses (<http://www.cluin.org/programs/21m2/openpath/>). It also contains a searchable database with over 5,400 abstracts and articles updated quarterly with open path technologies and CEMs being part of the updates (<http://www.cluin.org/programs/21m2/litsearch.cfm>).

Panel of Previous Speakers

The common message of the speakers is that it is technologically possible to obtain hydrocarbon flux values using the DIAL system, locate individual leaks using the IR camera, and speciate and quantitate the plume using FTIR. The studies presented, including multi-year studies, indicate that the actual emissions from petroleum facilities are much higher than would have been calculated using emission factor methods.

QUESTION AND ANSWERS

Question. What are the obstacles to adoption of this technology? Why should we move in this direction?

Answer. From the Canadian perspective, the plant level operators appear to be accepting the technology and appreciate seeing the measurement results. While the DIAL measurements are not finalized in real time, preliminary results can often identify large releases and allow the DIAL operators to interact with the plant personnel to help identify the source. A good example of this was the gas plant pressure relief valve. Roadblocks include the cost of the survey because it is not a required activity.

Answer. With reference to the FTIR systems, which have been available for at least 15 years, the roadblock is not so much cost as the system provides too much information. Showing a community what chemicals and concentrations they are being exposed to can result in community opposition. Also, in the case of chemical plants, there may be a concern that a competitor can use the measurement and speciation information for competitive advantage.

Answer. The U.S. industry objection to the DIAL studies performed to date is that the measurements occurred over too short a time and are therefore not representative. To overcome this objection, a way needs to be found to conduct long-term studies or to measure during different times of the day and seasons at the same facility.

Answer. In the UK, BP and Shell research/environmental groups have used the DIAL system for measuring emission fluxes; however, they too had difficulty selling their services to their own plants. If monitoring is not required, then the business case falls between the environmental staff and the production staff. Production staff tend to have a very short-term outlook and a reluctance to closing the plant for repairs. They may ignore studies that show a long-term payback.

Answer. The infrared cameras are having the opposite problem. They are relatively cheap and industry sees them as a way to detect leaks more cheaply than with other technologies; however, they need to be employed with full knowledge of their limitations. These cameras can only see a small number of chemicals. For example, unless a BTEX leak is very large the camera will not detect it. In addition, they have relatively high detection limits (100s of ppm) and do not quantify or speciate the chemicals.

Answer. From the Swedish perspective industry was initially opposed to plume flux measurements because they suspected that they would show problems that would require fixing. The provincial government required the study and introduced fines if it was not done. The studies have had mixed results on attitudes with some plants thinking they are a good idea or at least not a bad idea and others still are very much opposed to them. In the latter case it is mainly due to the fact that higher emission levels also require that more emissions-reducing measures be considered, which in its turn gives higher costs.

Answer. It is important when making a DIAL survey to have the cooperation and involvement of the plant staff. Communications between the survey crew and operations staff can help account for some apparent irregularities being detected by the instrument. Also it is very valuable to investigate what is happening at the time of the measurement. Examining plant records a few weeks later often will result in plant staff questioning the accuracy of the measurement since they don't see anything wrong; whereas, if they look at the leak at the time of the measurement, they might very well identify the problem.

Question. Is there not an eventual return on the cost through recovered product that would otherwise be lost?

Answer. It depends a lot on the industry. For example, at gas processing plants, many operations are based on throughput, and the staff bonuses are based on throughput. This emphasis means that staff will be concentrating on increasing throughput, rather than the recovery of emissions which are not captured in their bookkeeping.

Question. Has there been any sensitivity analysis on the input parameters or the assumptions that go into the calculation algorithms used by DIAL to produce the emission rate as measured versus the emissions as calculated? Is the gap real?

Answer. In Sweden this is not an issue anymore. The focus is in most cases not on putting limits on yearly emissions, because plant operations can vary substantially from year to year, typically due to start-up or shut-down operations, revamps and extensions. Rather, the emphasis is in identifying bad actors and finding ways to fix them. For example, if tank seals or piping flanges continue to show problems, it may be time to look at a different seal or flange gasket design.

Answer. In developing the DIAL system that was used in the Canadian projects, a number of tests were run to obtain the precision and accuracy of the instrument measurement so the uncertainties with actual DIAL measurements are well characterized. The issue comes when wind speed is added to get a flux value. In taking measurements of known source concentrations, the flux values are within 5 to 20 percent of actual values.

Answer. The flux values are generally within ± 5 to 10 percent of the true value assuming that there is good plume capture. DIAL measurements generally underestimate total emissions because small parts of the plume may be outside of the measurement plane.

Answer. The scans are conducted from various points around the plant. A number of scans are made at each point and averaged. The combination of the scan measurements provides a good statistical basis for the final estimates. For example, scans of any particular part of a plant are generally made from several different angles to ensure that as much of a plume is captured as possible.

Question. How many DIAL units are operating in the U.S., and are they ready to be rolled out here.

Answer. There are no DIAL units like those used by Spectrasyne in the U.S. The state of Texas is planning a study with the Spectrasyne DIAL unit in the Houston Ship Channel this summer.

Comment. It was suggested that this opportunity should be used to develop a standard protocol for DIAL. Germany has a standard protocol on DIAL, which might be of use, and the UK is working on UV-DOAS and FTIR with the potential for extending the effort to DIAL.

Answer. In the Canadian case the unit was brought from the UK by ship to Houston and then trucked to Alberta. There was a three person crew. Insurance might be an issue in the U.S. The typical survey cost, depending upon the size of the site, is between \$100,000 and \$200,000.

Question. The infrared camera as an alternative work practice is making its way through the regulatory system. Usually when this is done, a method is also written, but because the technology was evolving, a method has not been developed. Are there methods available to use and how effective will the camera be as a tool outside a laboratory setting?

Answer. Under the ETV program, EPA is starting a performance verification project on these types of cameras. Anyone interested in participating in the project is encouraged to join the stakeholder work group.

Answer. A methodology for using the camera could be developed and included in OTM-10.

Answer. One refinery, which has been using the camera for two years, is comparing it with their LDAR system. They have found that the camera does not detect low level leaks and cannot be used as a substitute. They are, however, still using it for safety and large leak detection.

Answer. In Texas, the camera was taken to three chemical plants and two refineries. The camera did not detect many emissions in the LDAR areas; however, the camera did show emissions coming from such points as sewers and wastewater treatment facilities that are not part of the traditional LDAR areas. There are a lot of source areas that are not being monitored and the camera is good at detecting them.

Question. Does the intensity of the image projected by the camera have anything to do with concentrations in the plume?

Answer. No. The intensity shown by the camera depends on a number of factors, and is not necessarily related to concentration. You might assume you have a large release, however, if the plume persists for some distance from the apparent source.

Question. Do you think that the level of investment that EPA's ORD is putting into the camera technologies is commensurate with the opportunity that is possible with the new technology?

Answer. Probably not. Research investment needs to be made in expanding the number of chemicals that can be seen and environmental conditions under which it works. As it stands now, there is little that can be done to account for changing conditions and hence whether the camera detects a plume or not. Currently EPA is not putting any funds into this technology. Funding is primarily coming from industry, DoD, and DOE.

The Problem of Uncounted VOC Emissions

Roy Huntley (EPA RTP), Teresa Hurley Texas Commission on Environmental Quality (TCEQ), Bill Johnson (EPA RTP), Ron Myers (EPA RTP), Rod Robinson (EMG/NPL/UK)

Roy Huntley. Inventories are used in air modeling and are a source of information for the general public. The RTP office does not generate inventories but uses what the state and local agencies provide. An accurate inventory that includes as functioning, rather than as designed, facility estimates is important when trying to decide where efforts and resources should be placed to reduce emissions.

Teresa Hurley. Houston has a very bad attainment problem. If the contribution of all the industry along the Houston Ship Channel was removed from the inventory, the area still would not be in compliance with the ozone standards. The state has just finished writing restrictions on emitting highly reactive volatile organic compounds (HRVOC) that form ozone very quickly. Industry in the area is well regulated and the LDAR program (no emission to exceed 500 ppm) is strictly enforced. When the IR camera is brought onto a site, leaks in the LDAR areas are rarely found; however, when the camera is aimed high where LDAR is generally not done due to the difficulty of getting a detector close enough, it begins to show detectable leaks and also provides evidence of emissions from sources that were previously not considered as such. Without good quantification of emissions it is difficult to write cost-effective standards (attacking the worst sources first).

Ron Myers. Although emission factors have their place, and there are areas where emission factors are not effective. The RTP office has a report that will soon be out for review that examines the uncertainties associated with emission factors and the use of emission factors for various purposes. Even the best of the emission factors have an uncertainty that is two orders of magnitude around the emission factor, especially when

used for individual compounds. They may behave a little better when used for classes of chemicals, such as VOCs. When there is a large variation in emissions and a single value emission factor is being applied to a single facility, then the estimate could be off by an order of magnitude or more. If that facility is a major source in the area, then there will be a major problem in trying to reduce emissions, since the source will be unknown. The office also is interested in the application of best measurement technologies to quantify emissions. After selecting a technology, a measurement technique should be applied to continuously monitor the source either by looking at parameters within the plant or measuring the contaminant directly to ensure the equipment is working as designed. The bottom line is that actual measurements are needed to ground truth the emission concentrations and not rely on factors that were developed in the 1970s.

Bill Johnson. EPA works with state and local agencies to develop state implementation plans (SIP). The SIP is built on modeling to determine how much emissions reductions are needed to meet the standard. Rules are written to obtain the reductions from sources in the area. Hence, it is important to know where the emissions are coming from. In the Houston area, it was noted that the ambient levels of HRVOCs were much higher than would be expected given the inventory levels, and a conclusion was made that fugitive emissions sources were the cause. Fugitive emissions could be a major source in some areas, but before a state can take credit for their reduction, they must quantify them, which requires direct measurement. Another area of office interest is emissions from underground storage tanks. These releases appear to be much higher than originally thought, but like the fugitive emissions, need to be quantified.

Rod Robinson. The NPL began about 10 years ago to compare DIAL measurements with emission factor estimates to determine how different they might be. On average, the DIAL measurements were about three times higher than the emission factor estimates on a plant wide basis. In areas covered by a monitoring and repair program, the differences were not large; however, in unmonitored areas significant releases were found. In the UK, the local authorities are responsible for addressing air pollution sources. In general the predominant problem is with vehicular traffic; however, as was mentioned for Houston, measurement of ambient air quality values often shows concentrations that are higher than would be expected with the source inventories and are likely attributable to fugitive emissions. Legislation on air pollution has become stricter, but the predominant method for estimating it is still based on modeling emissions estimates, not on direct measurement.

QUESTIONS AND ANSWERS

Comment. A group in Edmonton has been doing work on ozone modeling and their results have not been good; however, after looking at the results from the DIAL studies they began to think that it might not be a model problem but an underestimation of the pollutant loading. By adjusting the API estimation factor input by a factor of five, the model outputs began to come in line with the ambient measurements.

Question. Does anyone know what the contribution to total emissions from offshore gas and oil production facilities is?

Answer. No.

Comment. In the studies around Houston, fugitive emissions or leaks from unconventional sources are not the only problem. The TCEQ has found in many cases that the emission factors are not being applied correctly or that the equipment is not operating as designed. For example, the large additional emissions from tank roof landings are not supposed to be happening, because that is not supposed to be a normal operating procedure. Until recently, tank roof landing was not part of the emission factor calculations so the resulting emissions were not reported. Now that they are, the state is seeing a considerable increase in reported emissions from these operations. Emission factor estimations as currently done do not necessarily provide an incorrect estimate so much as they provide an incomplete estimate. Direct measurement of plant emissions is a way to identify areas for improvement, not necessarily to replace emission factor estimations. The issue should not be framed in an either/or fashion.

Comment. In the chemical industry there is increasing resistance to quantification of whole plant emissions. They appear to be more interested in identifying sources and correcting them. While the latter is good, it makes it difficult for regulators to frame strategies for SIP compliance measures. For example, if you do not know you have a major bad emissions actor, you may turn to regulating outdoor barbeque grills.

Comment. Emission factors were developed statistically to allow projection of emissions for a certain activity. They were meant to be applied over a broad area with many facilities, but when applied to a single facility there is no averaging out and the accuracy is suspect. For individual facilities more specific data are needed.

Question. Could you comment on the flare study?

Comment. The study was done at John Zink to test whether an open path FTIR could be used to measure flare emissions (main question of whether the presence of water and CO₂ interferences could be overcome). The results indicated a good potential for FTIR to be used for monitoring flare emissions. Another study has shown that when the wind speed is greater than five miles per hour the flare efficiency drops significantly. The emission factor for flare estimation is based on a flare operating in still conditions.

Comment. The DIAL system was used in the Canadian studies to look at flare efficiency. It can measure ethylene, the product of flare combustion, directly. The studies found that flare efficiencies varied between 75 and 98 percent. Flare emission factors that give flares a 98 percent efficiency were determined in the 1970s under still wind conditions.

Comment. The San Francisco Bay Area Air District has a flare monitoring program that has been in place for about a year and the data are now being analyzed. The District is proceeding to write a flare control rule that asks refineries to submit plans to minimize flaring to the maximum extent practicable. These plans will be offered for public comment the first part of 2007. Some refineries are rebuilding their compressors to expand their temperature range so lower molecular weight gases can be compressed to reduce flaring. One refinery has committed to not flare any gas that has not been treated to remove H₂S.

Question. Can the CAFO example be applied to the oil and chemical industry?

Answer. CAFOs are confined animal feeding operations that produce a large amount of animal wastes. An enforcement action against the industry resulted in a fine and a consent agreement to fund and carry out an emissions study. The \$20 million study will use continuous TDLS tomography at 20 to 22 facilities to measure ammonia emissions from holding lagoons.

Comment. Before industry can be approached with the total plant monitoring concept with DIAL alone or combined with the IR camera or other technologies, EPA will have to have a uniform protocol in place that explains to industry what they are expected to do, what the repercussions may be, and what may be found with the data.

Joe Paisie. Mr. Paisie was recently in the HQ Office of Policy Analysis and Review where he had heard of DIAL and the IR camera but had not had anyone formally approach the office about findings. The magnitude of the underestimation of emissions, their composition and potential health impacts, and the geographical areas where they are occurring need to be brought to the attention of the policy office so they can decide whether the Agency needs to address them.

Regulatory and Permitting Options and Experiences

Barrett Parker (EPA RTP), Brenda Shine (EPA RTP), Robin Segall (EPA RTP), Roy McArthur (Environment Canada), Lennart Frisch (AGENDA ENVIRO AB)

Barrett Parker. Emissions measurement is very important if you want emissions reduction. As the technologies become available, the Agency should be moving toward direct continuous measurement of the pollutant of concern. This will not be easy as there is always resistance to change.

Brenda Shine. EPA's RTP office is currently developing individual risk standards for the Maximum Allowable Concentration (MAC) program, which includes petroleum refineries. The office is also starting a multi-pollutant project on petroleum refineries to prioritize issues and design voluntary program approaches to address them.

Robin Segall. From a historical stand point, it has been difficult to find methods to measure fugitives. In the early 1990s EPA determined that FTIR was not sufficiently accurate for regulatory purposes; however the technology has matured and the detection limits are now acceptable. In the near term, there is clearly an opportunity to take another look at the emission factors. Measurements made on tanks have shown that there are issues with using emission factors that need addressing. A study should be done using all the technologies to compare and validate what each technique is showing. This study would also provide a better idea of how these instruments can be used to complement each other and give the stakeholders (operators and regulators) a better comfort zone with the techniques. As Joe Paisie said this morning, as a senior policy maker he had not heard a lot about the remote sensing findings. A study that does what is described above (and has a favorable outcome) would go a long way toward encouraging the technical staff to take the problem to the policymakers. These instruments also show promise in helping the states identify sources that are contributing to attainment problems. Finally, imaging cameras and passive FTIR instruments can find a use in emergency response applications.

Roy McArthur. The pollution data branch of Environment Canada is responsible for developing methods for pollution inventories, including innovative technologies, such as DIAL. While the upstream gas producers in Canada have clearly seen the benefits of the new technologies, the refineries are going to be more difficult to deal with. Other stakeholders include upper management of the regulatory agencies. As was pointed out by Lennart Frisch, there was an initial resistance by government management in Sweden to adopting a new way of conducting business. The survey done at the Edmonton refinery showed that the plant was losing about 0.17 percent of throughput to fugitive emissions. The contractor who did the work has considerable experience in surveying refineries and thought the Edmonton facility was very well run. The results of this survey allow the Agency to craft a conservative estimate of total losses from refineries in Canada and to present the estimate to Agency management who need to understand the magnitude of the problem. The findings also will be of interest to the public at large and can be used to generate support for change.

Lennart Frisch. In Sweden there are 21 provincial governments (another equivalent translation is County Administration Boards). The provincial governments enforce general environmental regulations set by the national government and the Ministry of Environment as well as plant specific conditions set by an Environmental Court procedure based on the national Environmental Code, forming specific emission limits in a permit. Enforcement issues are carried out at the provincial level with appeal possibilities to the Environmental Court—a branch of the district court system, numbering five in Sweden. When convincing industry to take measures, it is very important to state

what is wanted and why. There is currently a body of evidence that shows there are emission problems that can cause health problems (e.g., aromatics), ozone issues, and other things. Because there are different issues, it is important to be very specific about what needs to be measured and reported for each single plant. In Sweden the enforcing authority also can force the plants to carry out measurements that are fully paid for by the plants. All facilities are obligated to carry out a sufficient number of measurements to ensure their proper environmental performance.

There should be no fear of annualizing emission figures. The DIAL provides a very conservative estimate because it does not necessarily capture the whole plume. In addition, the studies that have been done have occurred under different climatic, environmental, and operating conditions with the common result that they always show that the facility has higher emissions than what would be the case if emissions data had been based on traditional theoretical calculations. The general report on VOC-emissions development in Sweden ([Frisch 2003](#)), but also to one report carried out by DIAL, showing data for the Preemraff refinery in Lysekil (former Scanraff), done by Spectrasyne Ltd ([Spectrasyne 1999](#)), and the report on measurements carried out by the SOF system, done by the Chalmers University of Technology ([Kihlman et al. 2005](#)) all support this finding.

Rather than setting specific emission levels limits for a facility, it is often better to focus on what can be done to reduce the emissions, such as double seals for tanks or better flange gaskets. When initiating the measurement studies, invite as many people as possible from the regulatory community to expose them to what can be done and why. From the European experience, it is important that the measurements taken be in the public domain for all to view. This public scrutiny maintains pressure on the government and industry to act to mitigate the releases.

There are real health and environmental problems associated with not controlling fugitive emissions. The first step in controlling them is to optimize the measurements. Past experience shows that the first DIAL measurement always pays off for industry. A way of dealing with the flare problem is to restrict the amount of gases that can be flared. It is also important to obtain the cooperation of industry. Their fighting the measurements is detrimental to both sides.

QUESTIONS AND ANSWERS

Comment. It is good that EPA is putting together the uncertainty report, but the Agency needs to further clarify its position that emission factors are not the best way to calculate emissions that actual measurements are needed. "Take measurements" is not a message that is being heard outside the EPA.

Question. There is a recent Inspector General report ([EPA 2004](#)) that has some findings about emissions factors among other things. Would this not be a jumping off point for these issues, and does there have to be a formal response?

Answer. Yes, there does have to be a response. The report essentially said the Agency does not have enough factors, the ones that are in place are wrong, and it is too difficult to use the factors. EPA is developing an uncertainty report that shows how inaccurate emission factors can be and is in the process of automating the calculation system. While emission factors are useful, and will continue to be useful, given their uncertainty they should be used with care.

Comment. As a local regulator, these findings are very disturbing; however, we do not have the budget to fund a DIAL study. It would have to be done by industry and the agency would be hard put to try to compel industry to conduct these measurements when it is not being done elsewhere. EPA has to take the lead here so that we all speak with one voice that this monitoring needs to be done.

Comment. About 90 percent of the refining capacity in the country is under a consent decree and while the Agency has control of some processes, fugitive emissions is not one of them. In the past, fugitive emissions have been very difficult to quantitate and speciate and this type of data is needed to assess risk. With the residual risk program, emissions are modeled and the risk estimated. If the risk is found to be significant, the question arises of how can it be reduced—especially when the distribution of specific chemical emissions among sources is not known with any certainty. The EPA has gone to industry and proposed that they develop some kind of spatial monitoring program that performs continuous monitoring for benzene (primary risk driver). If the monitoring shows a risk then it would be up to them to determine what should be tweaked in their process to lower the risk. Industry has declined to do this and has indicated that their preference is for the Agency to develop measures that can be checked off to show compliance.

Comment. EPA does have the right to audit a facility. If EPA shows up with a DIAL system and finds out of control sources that result in fines, maybe industry will start monitoring themselves to avoid the fines.

Comment. In doing residual risk calculations, EPA does not typically consider all emissions. For example, EPA would not look at upsets, unplanned and infrequent events, and chronic malfunctioning of equipment, which is a big gap.

Forthcoming Studies in the U.S. and Canada

Russ Nettles (TCEQ), Ken Garing (EPA NEIC), Roy McArthur (Environment Canada)

Russ Nettles. A Texas Air Quality Study was performed in 2000. This study showed, among other things, that the ambient concentrations did not agree with the inventories. The study estimated the inventories were understated by 6 to 20 times. The state brought in a company to audit the plants to see if they were following the guidelines. The audit found that for the most part the plants were in compliance. Following a story in the Houston Chronicle about a specific plant, an audit was performed using an IR camera. The camera found wastewater, compressor, and tank problems. The LDAR areas had very few detectable releases.

In a second project, a camera in a helicopter was used to over-fly the Houston Ship Channel. The primary problems found were with the bulk terminal tank for-hire facilities that tended to frequently land their tank roofs. The survey also indicated that only a small percentage of the tanks examined showed signs of releases. This could indicate there was a problem with the camera or that the emission factor estimates are good as long as the tank is functioning as designed.

The state conducted an oil and gas project to examine storage tanks in the oilfields. The tanks contain product, crude, and condensate. Thirty-three tank batteries were tested by manifolding each battery's tanks together and measuring emission flow with a thermal mass flow meter. The largest estimated release was 1,600 tons per year from a tank battery in Galveston County. That is about 10 percent of the Houston Ship Channel inventory. Based on the derived factors and reported production data, the whole state has about 1.5 to 2.5 million tons of VOC emissions per year at an approximate value of \$800 million. These releases are not difficult to recover.

Another project examined compressed gas (butadiene) loading on rail cars. At one facility, all the cars that were being unloaded were leaking where the nipple goes into the valve. The project estimated losses at 3 to 5 tons per year.

An ambient survey performed in 2006 indicates that there is still a wide difference between ambient VOC concentrations and the amount of inventory needed to produce them. The DIAL system, especially to examine tanks and flares, seems like the most logical next step to try to identify emission sources.

The Texas DIAL project currently has about \$340,000 and will take place at facilities in the Houston Ship Channel area. Mr. Nettles welcomes input on things to include in the study. Currently they have not identified host sites.

Ken Garing. Industry's view of the IR camera falls into two camps. The first consists of companies that assume the system will only get better or written into a rule and they need to obtain one and find leaks before the government or public finds them. This is the larger group. The other group is waiting for a rule to be written. When cameras are used, they are not generally employed for Method 21 monitoring. Some refineries are

using cameras before start up to ensure the process is tight. Others are using cameras for safety purposes and for finding really big leaks. The camera does not appear to be able to detect releases under 500 ppm. For example, a walk through a typical refinery with the camera may find 30 items that need repair. A Method 21 survey will generally find several hundred, which is why industry is anxious to have it as an alternative work practice.

There is a project starting at a refinery soon that will use the camera to locate leaks and then will bag and quantify them. EPA will be at the plant at the same time using Method 21 to see if they can find large leaks that the camera does not detect and bag them for quantitation and speciation.

NEIC is planning an experiment if a host and agreeable regulator can be identified where the facility will do the normal Method 21 survey and estimate emissions but not fix anything found. A camera will be used every two months to take a survey and any releases it finds will be repaired. At the end of the year they should be able to tell whether fixing only camera detectable releases works as well as the fixes using Method 21.

QUESTIONS AND ANSWERS

Question. Is there any need to have an advisor from the National Science Advisory Board or National Academies of Science other body to lend weight to the effort?

Answer. Validation is going to be an issue so the effort will need to be nearly flawless. If a national technical advisor could be made available, all the better.

Small Group Discussions

Attendees were divided into groups to address five specific issues and make recommendations on each.

Monitoring Applicability in the Petroleum Industry

DIAL is well suited for characterizing fugitive emissions in this industry; however it has a high cost and limited availability. The Agency should think about developing it as a centralized system (e.g., TAGA (Trace Atmospheric Gas Analyzer)) that can be deployed at strategic locations around the country. Duplicating the current configuration for the DIAL system would probably cost on the order of \$3 to \$4 million per vehicle.

Before investing this amount of money, there is a need to demonstrate DIAL in the U.S. to show that it will provide the information that the state and local agencies need for an accurate inventory. The demonstration should be a long-term project to answer the

questions that API is raising about current studies being a snapshot and not representative. This might include bringing the instrument onsite every three months to measure operations at these times and under different climatic conditions. The study should also include continuous fence-line monitoring by FTIR to provide average daily concentrations and the FTIR monitoring should have a sufficient vertical plane to capture all parts of releases leaving the plant property. The plant might be asked to use an imaging camera along with their Method 21 LDAR surveys. At the end of the year all data should be compared to identify trends and gaps and determine how different emissions factor inventory estimates are from the DIAL and FTIR results.

Regardless of potential actions that could be taken to further demonstrate these systems, there is a need to present the DIAL studies and their implications to top level policy people at federal, state, and local levels.

The infrared camera is being pushed by industry and the alternative work practice rule is on a fast track. EPA needs to ensure that there is good science behind this rule. This means there needs to be a full Agency evaluation of its capabilities. The ETV study mentioned earlier may aid in this evaluation but will not necessarily provide all the information required. As currently configured, the camera is not capable of looking at every tank that might leak regardless of contents, nor of picking up low level releases. The results of the evaluation could be used to develop an infrared camera method that could be incorporated into OTM-10.

Incentives

- For some companies, insurance rates might be reduced if these instruments could be shown to reduce the probability of adverse reactions from undiscovered releases, hence leading to their adoption and use.
- As was shown with the CAFO industry, regulatory agencies might require conducting DIAL or infrared camera studies as part of a consent decree or supplemental environmental project (SEP).
- Consider whole-plant testing instead of individual source testing and compare costs. If the whole plant testing is cost-effective, the requirements for individual stack and other point sources within the plant area could be relaxed.

QUESTIONS AND ANSWERS

There were no questions following this presentation.

Monitoring Applicability in Related Fields

This workshop has shown that the technology exists to measure facility fugitive emissions plant wide and that the current method for estimating inventories does not capture all emissions.

Applications for Open Path Technologies

- Law enforcement (e.g., identifying chemicals in methamphetamine laboratories).
- Homeland security (e.g., identifying chemicals in carry-on luggage, monitoring for the presence of chemical agents in the air at public gatherings).
- Monitoring emissions from mobile sources, such as aircraft, vehicles, railroads, marine barges, and cargo vessels.
- Determining fugitive emissions from animal feed lots.
- Determining fugitive emissions from landfills.
- Monitoring fugitive emissions from wastewater treatment plants.
- Whole plant monitoring of chemical manufacturing facilities.
- Stack monitoring at power plants.
- Monitoring fugitive emissions at ethanol/biodiesel plants.
- Superfund and RCRA site remediation applications.

To implement better monitoring systems, constituent groups need to identify funding sources. All government players (federal, state, and local associations) need to work together and share information.

Barriers to Establishing a Better Monitoring System

- A lack of connection with existing methods (i.e., how do the values obtained by existing methods compare with the open path ones?).
- The political climate is not conducive to introducing monitoring techniques that may cost industry more money.
- Government funding for implementation efforts is not currently available.
- Validation of the methods. The infrared camera is highly qualitative in interpretation and needs a standard operating procedure. The DIAL and radial plume mapping techniques have been validated but there is a question concerning their representativeness.
- Availability of equipment. Infrared and OP-FTIR equipment are readily available, the DIAL system used in the Canadian and European studies is not.
- Industry resistance.
- Transparency of data (making data public).

Recommendations

- Open path technologies should be incorporated into the air monitoring program to improve quantification of total emissions.
- A better system for exchanging information needs to be designed and implemented. The system would include keeping all parties aware of studies being conducted across the country in this area (e.g., the DIAL study being planned for Texas).
- Objective studies to determine the application and limitations of the technologies need to be conducted.

- Funding of these studies should be pursued through SEPs and partnering with industry.

QUESTIONS AND ANSWERS

Comment. It may be worth investigating the creation of an Internet website that is available to government personnel to exchange information. The website could be interactive allowing staff to freely upload and download material or it could be controlled by giving a select group of individuals uploading privileges.

Comment. Internet seminars are also a good tool for exchanging information and training. Dan Powell's office can assist with putting these on.

Question. What is meant by data transparency?

Answer. The data collected should be fully public. Industry may resist revealing the concentrations of various chemicals leaving their facility.

Needed Changes to Emission Inventories and Models

The Canadian and European studies indicate that fugitive emissions at petroleum handling (and other) facilities are much higher than would be indicated by emission factor estimates. This is apparently caused by:

- Exclusion of upsets, malfunctions, startups, and shutdowns from the emissions inventory.
- Large VOC emissions that are present from unexpected sources (heat exchangers, process sewers, cooling towers).
- Source areas that are currently excluded from the inventory estimates.
- Not using actual tank parameters to estimate emissions and get information on malfunctions.

The studies also show that there is a need for better, more accurate information than is currently available and that this information should be used to create/improve emission factors and annual emission estimates to bring them in line with the total plant monitoring data.

The studies show that in many cases the largest percentage of emissions comes from a small number of sources that often are not monitored.

Potential incentives for implementing/improving whole plant monitoring include:

- Developing a process where divisions within an agency work together instead of independently to characterize emissions (e.g., inventories, permitting, enforcement). Improve the use of data already collected.

- Develop collaboration with industry.
- Emphasize that emission losses subtract from profit.

Barriers to better monitoring include industry culture (resistance to change) and the cost of the monitoring.

Recommendations

- Facilities should be required to identify major sources of emissions and mitigate them. These sources are often not part of the LDAR program.
- The API emission factor methodology needs review.
- The government needs to develop consistent methodologies for using the new emissions monitoring approaches.
- Incentives should be created to decrease emissions and improve emission inventories (more measurements lead to better inventories).
- Flexibility should be developed in SIP requirements, enforcement discretion, and Title V deviation when using new technologies.
- Liability should be limited when using new technology (do not punish a facility for finding new sources).
- Parameters (e.g., throughput) should be added to the Toxic Release Inventory and the Canadian National Pollutant Release Inventory to make screening/comparison between refineries easier.

QUESTIONS AND ANSWERS

Question. Do you have any specifics about how to get agency divisions to work together?

Answer. One method is to make staff more aware of what other offices do and their information needs and share information that is of interest to more than one office. Another method is setting up an inter/intra office database that all stakeholders can access.

Question. Does Texas have any plans about involving the public in helping to pick a host for the DIAL study?

Answer. The state has not thought that far ahead.

Comment. The idea of limiting liability for using new technology to locate sources is a good one. There are examples of facilities voluntarily sampling something at the request of an agency and then being sued when a release is found. Such actions tend to dampen industry enthusiasm for trying something new, especially when they think they have a good probability of finding something.

Comment. Texas has an incentive system based on permit approvals. If a facility does not have any violations their permit is placed at the front of the line while facilities with bad records are placed at the end of the queue. Placement at

the front of the permits queue might be an inducement for a facility to allow a DIAL survey.

Legitimizing the New Methods—Rules, Guidance, Work Practices

The workshop has shown:

- There are more emissions leaving facilities (refineries) than was thought and current methods do not measure all emission sources.
- There is a need to measure total emissions, but there currently are no protocols or requirements to do so.
- There are tools that can measure total emissions.
- OTM-10 provides a framework for using these tools.
- There is a gap in the current procedures and protocols.
- There is a discrepancy between total emissions based on emission factors and total emissions when measured.
- There is a need to get environmental agency management and industry attention.

Barriers to Introducing New Methods

- Funding/cost of DIAL.
- DIAL equipment availability.
- Finding industrial sites for demonstrations of all three technologies.
- Lack of awareness of problem and of measurement technology.
- Rule paradigm shift needed away from stack emission limits to plant-wide limits.

Recommendations

- A community of practice of tools should be developed.
- Instrument specific measurement protocols should be developed/published.
- Studies and other information on the use of these tools should be collected and disseminated.
- Demonstrations using these tools to show efficacy should be undertaken. A good place to start is with the Houston study. A very good QA plan for Houston is needed as the first U.S. study must be a model effort. Rod Robinson of the National Physical Laboratory in the UK volunteered to help in the development of the QA plan.
- EPA headquarters management should be made aware of the studies and their implications. NEIC volunteered to help raise the issue at headquarters.
- The concept of a plant-wide application limit as an innovation could be introduced into a plant permit.

QUESTIONS AND ANSWERS

Question. How can the states get technical assistance from ORD or NEIC?

Answer. Write a letter to the EPA Regional Office formally requesting it and they can make the request on your behalf. ORD also has a program for technology assistance that is available from the regions.

Implementation Issues–Beyond the Rule

- Canadian and European studies show emissions are underestimated. Texas data show ambient VOC/NO_x ratios do not match inventories, which implies the inventories are low.
- Data indicating that emission inventories are understated need to be brought to the attention of top management.
- Policy makers at state and local levels need better data for air quality planning.
- The open path technologies have potential to give us better data.

Barriers to Introducing New Methods

- Cost of monitoring.
- Availability of equipment.
- Need to convince policy makers at all levels that understated inventories are an issue.
- Industry/political objections.
- Management of risk communications.

Potential Incentives

- Exempt DIAL measurements from "credible evidence" for a period.
- Use state/local emission inventory program to encourage or require the use of actual data.
- Open trading programs to fugitive emissions if the site measures emissions.
- Encourage measurement pilot programs (has site selection issues).
- Military bases have been used before to demonstrate new technologies. Would it be possible in this case? The Environmental Security Technology Certification Program (ESTCP) run by the military also might be a way to demonstrate the technologies.
- Indoor air may be a good place to start demonstrating the technology. There is not a lot of enforcement in the area. If a building is touted as green, could these technologies be used to show there are no volatile chemicals in it?
- Offend as few as possible with actions.

Recommendations

- Communicate fugitive emissions issues to management and industry.
- Involve the State and Territorial Air Pollution Program Administrators (STAPPA) and the Association of Local Air Pollution Control Officials (ALAPCA).

- Expand OTM-10 to include infrared (imaging) cameras—move to rulemaking for acceptance.
- State and local regulators need to put together formal letters to EPA saying they understand that emissions factors are inadequate. Tell us how to make them adequate; what measurement needs to be performed. The states are restricted in what they can do and need EPA to take the lead. If EPA wants OTM-10 used then they have to promote it.
- Investigate using residual risk under the Maximum Achievable Control Technology (MACT) program as a driving force.
- Since the DIAL system is being brought from the UK for the Houston Ship Channel test, it would be useful to try to line up ETV or ESTCP type demonstrations to take advantage of it.

Action Items

John Bosch, Measurement Policy Group, EPA

1. ORD needs to create a long-term research initiative in this area.
2. The workshop summaries should provide building blocks that can be used to present the findings and implications of the Canadian and European studies to agency management (federal, state, local) to make them aware of the problem.
3. Stakeholders need to participate in the study at the Houston Ship Channel to help ensure its success.
4. Ken Garing (EPA): Please provide John Bosch with a paragraph describing the NEIC approach for helping move the whole plant monitoring concept forward.
5. Explore incentives to using the camera and DIAL.
6. Legitimize the science.
7. Dan Powell (EPA) will look into what IT capabilities EPA has to share information.
8. Determine SBIR grants opportunities for this area of monitoring. Mike Adam will talk with the SBIR office at headquarters about this area and communicate with the air office as well as assess OSWER interest in developing capabilities.
9. Toby Allen (Northwest Clean Air) was requested to develop a letter to the regional office requesting technical assistance for emissions monitoring to be used as an example for other state and local agencies.
10. OTM-10 needs to be finalized.

Summary

This workshop has shown that the technology exists to measure facility fugitive emissions plant wide and that the current method for estimating inventories does not capture all emissions.

Findings

DIAL

The DIAL systems under consideration have both an infrared and an ultraviolet component. The infrared DIAL is used primarily for alkanes although it can identify and quantitate hydrogen chloride, nitrous oxide, and methanol. Detection limits for the alkanes are in the 10 to 50 ppb range at distances up to about 800 meters. The UV/Visible DIAL can identify and speciate benzene, toluene, and xylenes in the 10-20 ppb range and is also used for elemental mercury, ozone, sulfur dioxide, nitrogen dioxide, and nitrogen monoxide. Detection limits are very dependent upon site conditions at the time of measurement.

In developing the DIAL system that was used in the Canadian projects, a number of tests were run to obtain the precision and accuracy of the instrument measurement, so the uncertainties with actual DIAL measurements are well characterized. The prime uncertainty factor is with the wind speed in calculating a flux value. In taking measurements of known source concentrations, the obtained flux values were within 5 to 20 percent of actual values. The DIAL system also has been validated in European studies for hydrocarbon emissions with calculated results ranging from ± 3 to ± 12 percent of the actual value.

The DIAL system may provide a conservative estimate because it does not necessarily capture the whole plume. Nonetheless, DIAL studies of 100-plus facilities executed under different climatic, environmental, and operating conditions always show that the facility has higher emissions than are reported.

The DIAL system has been used to:

- Quantify and calculate flux emissions from multiple sources within a complex plant.
- Identify and quantitate fugitive emissions to locate leaks.
- Calculate flare burner efficiencies.
- Conduct compliance monitoring including fence line surveys.
- Determine the ultimate destination of plumes originating at a plant.

Infrared Camera

Hand held thermal imaging (FLIR) cameras can rapidly scan for leaks; however, the detection limits and sensitivity of the cameras are not well known. Under one set of conditions a release can be detected while under a different set of conditions the same chemicals might not be seen. These changing conditions include air background, and gas temperatures and humidity. The commercial camera evaluated has a narrow band filter that limits the number of chemicals it can detect. At a given facility, what can be detected and what cannot is generally not known. The camera cannot speciate or quantitate a plume.

When the IR camera is used at a site, leaks in the LDAR areas are rarely found; however, when the camera is aimed high or at areas where LDAR is generally not done, it often shows leaks and provides evidence of emissions from sources that were previously not considered as such (i.e., do not have associated emission factors).

Some refineries are using cameras before start up to ensure the process is tight. Others are using cameras for safety purposes and for finding large leaks. The camera does not appear to be able to detect releases under 500 ppm. For example, a walk through a typical refinery with the camera may find 30 items that need repair. A Method 21 survey will generally find several hundred, which is why industry is anxious to have it as an alternative work practice.

One refinery, which has been using the camera for two years, has compared it with their LDAR system. They have found that the camera does not detect low level leaks and cannot be used as a substitute. They are, however, still using it for safety and large leak detection.

In Texas, the camera was taken to three chemical plants and two refineries. The camera did not detect many emissions in the LDAR areas; however, the camera did show emissions coming from such points as sewers and wastewater treatment facilities that are not part of the traditional LDAR areas. Many source areas are not being monitored and the camera is good at detecting leaks from them.

The camera can be coupled with a passive open path FTIR system. In this configuration, visual evidence of a leak is provided along with the ability to speciate and quantitate plume constituents. The passive FTIR can detect a much wider range of chemicals than the camera but it still has the same issues with changing conditions, such as air background, gas temperatures, and humidity.

Open Path FTIR Radial Plume Mapping

OP-FTIR Radial plume mapping uses a series of retroreflectors along a line of sight as well as at different heights to construct the average concentration found in a plume among segments. The segment concentrations can be used to locate hotspots and for constructing a vertical plane to provide a 2-dimensional concentration average. Combining this average with wind speeds gives an estimate of total flux leaving a site. The flux measurement can be improved if combined occasionally with the DIAL technology.

Emissions

The Canadian and European studies indicate that fugitive emissions at petroleum handling (and other) facilities are much higher than those indicated by emission factor estimates. This is apparently caused by:

- Exclusion of upsets, malfunctions, startups, and shutdowns from the emissions inventory.
- Large VOC emissions that are present from unexpected sources (heat exchangers, process sewers, cooling towers).
- Source areas that are currently excluded from the inventory estimates.
- Not using actual tank parameters to estimate emissions and getting information on malfunctions.

The problem with emission factor calculations is that they assume all equipment is operating as designed, they do not include some major release areas, and the LDAR programs typically do not measure tanks and difficult to access plant areas. Whole plant measurements typically identify problem areas not routinely monitored. In many instances, they allow for more efficient allocation of maintenance efforts by targeting the worst leaks first. Direct measurement of plant emissions is a way to identify areas for improvement, not necessarily a replacement for emission factor estimations. The issue should not be framed in an either/or fashion.

Other problems raised at the workshop involving emissions include:

- Several studies indicate that facilities using emission factor calculations can show that their emission rates are going down, but actual measurement of releases at these facilities does not support a release reduction.
- When the wind speed is greater than five miles per hour, flare efficiency drops significantly. The emission factor for flare estimation is based on a flare operating in still conditions, hence it is likely to understate actual releases.
- In performing residual risk calculations, the Agency does not typically consider all the emissions. For example, EPA would not look at upsets, unplanned and

infrequent events, or chronic malfunctioning equipment that may be causing sufficient emissions to create a risk.

Needs

The following needs were identified at the workshop (in no order of priority):

- Develop and deliver the message to senior policy makers at all levels of government that emissions at chemical and petroleum facilities are being under reported by a factor as high as 20 so that they might consider what actions are necessary.
- Determine the actual capabilities and limitations of the infrared camera and develop a protocol for its use.
- Conduct a DIAL study in the U.S. to develop protocols for its use and to demonstrate whether its measurements are representative of plant emissions.
- Develop better access to DIAL equipment.
- Develop a better understanding of the concentrations and species of chemicals being released from chemical and petroleum facilities. This is both for risk assessment and for determining which sources need to be targeted to meet air standards.
- Develop a system for exchanging information on emissions monitoring. The system would include keeping all parties aware of studies being conducted across the country in this area (e.g., the DIAL study being planned for Texas) as well as advances in technology.
- Revisit the API/EPA emission factor methodology.
- Require facilities to identify major sources of emissions and mitigate them. These sources are often not part of the LDAR program.

Recommendations

After considering the information presented at the workshop, the following major recommendations were made by the attendees. These recommendations are the result of the deliberations made at the workshop and have not been endorsed by EPA or other government agency.

- The magnitude of the under estimation of emissions, their composition and potential health impacts, and the geographical areas where they are occurring should be brought to the attention of top management in policy offices.

- A methodology for using the infrared camera that includes its limitations should be developed and included in OTM-10.
- EPA should take the lead in developing a policy on how to address the understating of emissions so that the regulatory community can speak with one voice. It will be difficult, if not impossible, for a local or state entity to try to compel industry to conduct these measurements when it is not being done elsewhere or advocated by EPA.
- EPA should be more emphatic on the position that emission factors are not the best practice and that measuring is the preferred method to determine emissions.
- A demonstration of the DIAL system together with other open path technologies should be undertaken in the U.S. This demonstration should include the development of protocols, including strict QA/QC measures, for the equipment's use, and it should at a minimum be sufficient to determine the chemical composition of the emissions and show that the measurements taken are representative of plant emissions in general.
- EPA should take advantage of the DIAL system being brought from the UK for the Houston Ship Channel test by actively supporting it and by finding other demonstration opportunities through mechanisms, such as the ETV or ESTCP programs.
- If the demonstrations prove successful, EPA should find access to a DIAL system for auditing purposes.

Appendix A: Agenda

INTERNATIONAL WORKSHOP

VOC FUGITIVE LOSSES -- NEW MONITORS, HIGHER EMISSIONS, AND POTENTIAL POLICY GAPS

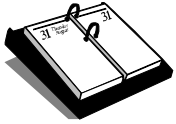

DATES

October 25-27, 2006

LOCATION

Auditorium, USEPA Campus
109 T.W. Alexander Drive
Research Triangle Park, N.C. 27711

SPONSOR

Office of Air Quality Planning and Standards, USEPA
Environment Canada
Office of Solid Waste and Emergency Response, USEPA

REGISTRATION

To register or for workshop details, contact Wade Peele, Workshop Coordinator at peelee.wade@epa.gov or at 919-541-4945. For further information, call conference manager, John Bosch, at 919-541-5583. **Seating is limited so attendees desiring to participate must pre-register by September 15, 2006 at the latest.** There is no registration charge.

BACKGROUND

In recent months there have been great advances in the detection and measurement of fugitive VOC emissions. Use of these new techniques in the U.S., Canada, and Europe shows a surprising quantity of hitherto unknown quantities of VOC being lost (emitted) nationally by the processing, distributing, and consuming of petroleum and petroleum byproducts. These new monitoring devices and field studies indicate that unexpected levels of fugitive VOC losses (currently defined as "leaks") could be emitted on a routine basis from storage tanks, pumps, pipes, cooling towers, wastewater separators, and the like. One study suggests that actual VOC emissions could be more than **fifteen times** the amounts previously estimated. These emissions are extremely important for two reasons: (1) they are end-products of the refining process which means they are both volatile and toxic (as opposed to the beginning crude oil) and (2) they occur throughout the national energy network ranging from well-head to refining to distribution to storage and retailing. These emissions are likely to have an impact on environmental control strategies and support activities.

PARTICIPANTS

- EPA's Office of Air Quality Planning and Standards
- EPA'S Office of Solid Waste and Emergency Response
- EPA's Office of Research and Development
- EPA's Regional Offices
- State and Local Air Pollution Control Agencies
- Environment Canada
- ARCADIS (presentation of scientific findings only)

PURPOSE

The purpose of the workshop is to (1) summarize the recent IR camera, DIAL, and radial-plume mapping findings and relate them to estimation methods now in use (2) review ongoing and imminent national and state studies as well as contract/grant resources/test sites potentially available for further confirmation studies, and (3) undertake a wide range of discussions on options available to national and state regulators in dealing with these fugitive VOC losses (i.e. regulatory, permitting, and enforcement). Impacts on emission inventory compilations will be addressed. Small group gatherings, panel sessions, and plenary meetings will be scheduled to enable the narrowing of these options to identify those most fruitful and cost-effective. A proposed plan of action and roles/responsibilities are expected workshop products.



ATTENDANCE

Workshop attendance will be limited to governmental environmental regulating authorities in the U.S., the U.K., and Canada. Selected scientific presenters from the private sector will be invited who are primarily involved with the emission-quantification technologies. We currently plan to offer another workshop at a later date to exchange information with the other private sector members, vendors, and regulated entities.

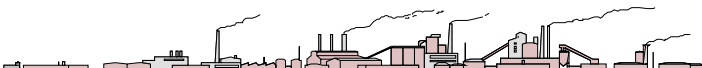

WORKSHOP AGENDA

Wednesday, October 25, 2006

- 12:30-1:30 p.m.**
- **Welcome and Keynote Speaker**
 - **Round-Table Introductions**
 - **Workshop Rules and Objectives**

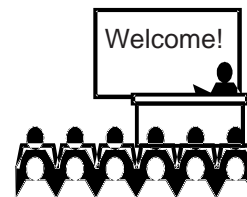

1:30-5:30 p.m. **The Science of Measurement-Fugitive VOC Emissions: Dr. Ram Hashmonay-ARCADIS**

- **Using DIAL to Measure VOC Fugitive Emissions:**
Allan Chambers, Alberta, Canada Research Council
- **Radial Plume Mapping:** Bruce Harris, ORD/USEPA
- **Infra Red Camera Use in the Chemical Industry:**
David Williams, ORD/USEPA
- **DIAL Emissions Monitoring in the United Kingdom:**
Rod Robinson, National Physics Laboratory, U.K.
- **DIAL Emissions Monitoring in Sweden:**
Lennart Frisch, MD, Agenda Enviro AB, Sweden
- **Ambient VOC Monitoring in Fort Saskatchewan and the Potential Impact of Fugitive VOC Emissions:**
Curtis Englot, Environment Canada, Ottawa
- **API Critique on the Use of DIAL for Quantifying VOC Emissions:** Rob Ferry, API Consultant

7:00 p.m. **Dinner at Selected Restaurant**

Thursday, October 26, 2006

8:00-9:30 a.m. **Panel of Previous Speakers:**

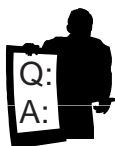

- What do these findings tell us?
- Questions and Answers

10:00-11:30 a.m. **The Problem of Uncounted VOC Emissions:
A Panel of Regulatory Scientists**

- Modeling, Emission Inventories, Control Strategies

11:30-12:30 p.m. **Lunch**

Thursday, October 26, 2006 (continued)

12:30-2:00 p.m. Regulatory and Permitting Options and Experiences



- What's been done? What might be done? A Panel of USEPA and International Regulating Authorities

2:00-3:00 p.m. Panel on Forthcoming Studies in U.S. and Canada

- Objectives, Participants, Funding, What more is Needed?

3:00-5:30 p.m. Small Group Discussions

1. Monitoring Applicability in the Petroleum Industry
2. Monitoring Applicability in Related Fields (i.e. chemical, ethanol, biodiesel, airports, retailing)
3. Needed Changes to Emission Inventories and Models
4. Legitimizing the New Methods -Rules, Guidance, Work Practices (i.e. ASTM, ISO)
5. Outlining the Response to the API Critique
6. Other (Suggestions?)

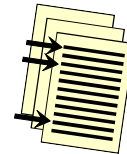

Friday, October 27, 2006

8:00-9:30 a.m. Continuation of Small Group Discussions

10:00-11:00 a.m. Presentation of Individual Group Findings by the Chairs.

11:30-12:30 p.m. Summary, Action Items, and Wrap-Up

Appendix B: Attendees

Name	Phone Number	E-Mail	Agency
Adam, Michael	703-603-9915	adam.michael@epa.gov	EPA HQ
Allen, Toby	360-428-1617	toby@nwcleanair.org	NWClean Air
Banker, Lalit	919-541-5420	banker.lalit@epa.gov	EPA RTP
Basala, Allen	919-541-5622	basala.allen@epa.gov	EPA RTP
Beeler, Cindy	303-312-6204	beeler.cindy@epa.gov	EPA R8
Bird, Bryce	801-536-4064	bbird@utah.gov	UtDAQ
Bivins, Dan	919-541-5244	bivins.dan@epa.gov	EPA RTP
Bosch, John	919-541-5583	bosch.john@epa.gov	EPA RTP
Boyes, William	919-541-7538	boyes.william@epa.gov	EPA RTP
Bushnell, Philip	919-541-7747	bushnell.philip@epa.gov	EPA RTP
Carr, Steven	919-357-6566	steven.carr@ncmail.net	NCDAQ
Chambers, Allan	780-450-5122	chambers@arc.ab.ca	ARCABCa
Chatfield, Ethan	312-886-5112	chatfield.ethan@epa.gov	EPA R5
Chin, Conrad	919-541-1512	chin.conrad@epa.gov	EPA RTP
Chu, Shao-Hang	919-541-5382	chu.shao-hang@epa.gov	EPA RTP
Ciolek, Mike	919-541-4921	ciolek.micheal@epa.gov	EPA RTP
Cole, David	919-541-5565	cole.david@epa.gov	EPA RTP
Desai, Sheila	312-353-4150	desai.sheila@epa.gov	EPA R5
Deslauriers, Marc	819- 994-3069	marc.deslauriers@ec.gc.ca	Environment Canada
Driscoll, Tom	919-541-5135	driscoll.tom@epa.gov	EPA RTP
Englot, Curtis	780-951-8873	curtis.englot@ec.gc.ca	Environment Canada

Frisch, Lennart	+46 (0)706 724 240	lennart.frisch@telia.com	AGENDA ENVIRO AB
Garing, Ken	303-462-9254	garing.ken@epa.gov	EPA NEIC
Hardin, Lacey	615-532-0545	lacey.hardin@state.tn.us	TNDAPC
Harris, D. Bruce	919-541-7807	harris.bruce@epa.gov	EPA RTP
Hashmonay, Ram	919-564-4535	rhashmonay@arcadis-us.com	Arcadis
Herring, Jeff	919-541-3195	herring.jeff@epa.gov	EPA RTP
Hirtz, Paula	919-541-2618	hirtz.paula@epa.gov	EPA RTP
Holt, Jim	901-544-7737	jholt@co.shelby.tn.us	Memphis & Shelby Co., TN HD
Homolya, Jim	919-541-4039	homolya.james@epa.gov	EPA RTP
Hoyt, Dan	713-640-4365	dan.Hoyt@cityofhouston.net	City of Houston, BAQCEHD
Hurley, Teresa	512-239-5316	thurley@tceq.state.tx.us	TCEQ
Hustvedt, Kent D.	919-541-5395	hustvedt.ken@epa.gov	EPA RTP
Huntley, Roy	919-541-1060	huntley.roy@epa.gov	EPA RTP
Johnson, William L	919-541-5245	johnson.williaml@epa.gov	EPA RTP
Jones, Mike	919-541-0528	jones.mike@epa.gov	EPA RTP
Kilpatrick, Donna Jean	819- 997-5111	donnajean.kilpatrick@ec.gc.ca	Environment Canada
Law, DJ	312-886-6024	law.donald@epa.gov	EPA R5
Logan, Tom	919-541-2580	logan.thomas@epa.gov	EPA RTP
Loukeris, Constantinos	312-353-6198	loukeris.constantinos@epa.gov	EPA R5
Markwordt, David	919-541-0837	markwordt.david@epa.gov	EPA RTP
McArthur, Roy	819- 953-9967	roy.mcarthur@ec.gc.ca	Environment Canada

Mickunas, Dave	919-541-0837	mickunas.dave@epa.gov	EPA RTP
Middleton, Carrie	303-462-9270	middleton.carrie@epa.gov	EPA NEIC
Mikel, Dennis	919-541-5511	mikel.dennisk@epa.gov	EPA RTP
Mobley, David	919-876-4873 541-4676	mobley.david@epa.gov	EPA RTP
Mouton, Jenifer	225-219-3427	jennifer.mouton@la.gov	LAOEAAQAD
Myers, Ron	919-541-5407	myers.ron@epa.gov	EPA RTP
Nettles, Russell	512-239-1493	rnettles@tceq.state.tx.us	TCEQ
Pagan, Jaime	919-541-5340	pagan.jaime@epa.gov	EPA RTP
Painter, David	919-541-5515	painter.david@epa.gov	EPA RTP
Parekh, Samir	919-715-0751	samir.parekh@ncmail.net	NCDAQ
Patel, Shilpa	312-886-0120	patel.shilpa@epa.gov	EPA R5
Parker, Barrett	919-541-5635	parker.barrett@epa.gov	EPA RTP
Paser, Kathleen	303-312-6526	paser.kathleen@epa.gov	EPA, R8
Pelletier, Patricia	819- 953-9441	patricia.pelletier@ec.gc.ca	Environment Canada
Powell, Dan	703-603-7196	powell.dan@epa.gov	EPA HQ
Pridgen, Hamp	407-836-1411	hamp.pridgen@ocfl.net	OCEPD
Rackley, Karen	919-541-0634	rackley.karen@epa.gov	EPA RTP
Robinson, Rod	+44 20 8943 7146	rod.robinson@npl.co.uk	EMG/NPL/ UK
Rust, Gary	919-541-0358	rust.gary@epa.gov	EPA RTP
Segall, Robin	919-541-0893	segall.robin@epa.gov	EPA RTP
Shine, Brenda	919-541-3608	shine.brenda@epa.gov	EPA RTP

Shores, Richard	919-541-4983	shores.richard@epa.gov	EPA RTP
Shrieves, Van Xavier	404-562-9089	shrieves.van@epa.gov	EPA R4
Snider, Andrew	819-956-9753	andrew.snider@ec.gc.ca	Environment Canada
Spann, Jane	404-562-9029	spann.jane@epa.gov	EPA R4
Sturdivant, Donnette	404-562-9431	sturdivant.donnette@epa.gov	EPA R4
Sutton, Don	217-682-7382 & 919-541-3046	don.sutton@epa.state.il.us	IL EPA
Taylor, Melanie	919-715-6257	melanie.taylor@ncmail.net	NCDAQ
Thoma, Eben	919-541-7969	thoma.eben@epa.gov	EPA RTP
Tooly, Lee	919-541-5292	tooly.lee@epa.gov	EPA RTP
Ulfig, Joseph	312-353-8205	ulfig.joseph@epa.gov	EPA, R5
Wee, Kelly	415-749-4760	kwee@baaqmd.gov	BAAQMD
Williams, David	919-541-2573	williams.davidj@epa.gov	EPA RTP

There were 74 participants in the workshop and their affiliation distribution is given below.

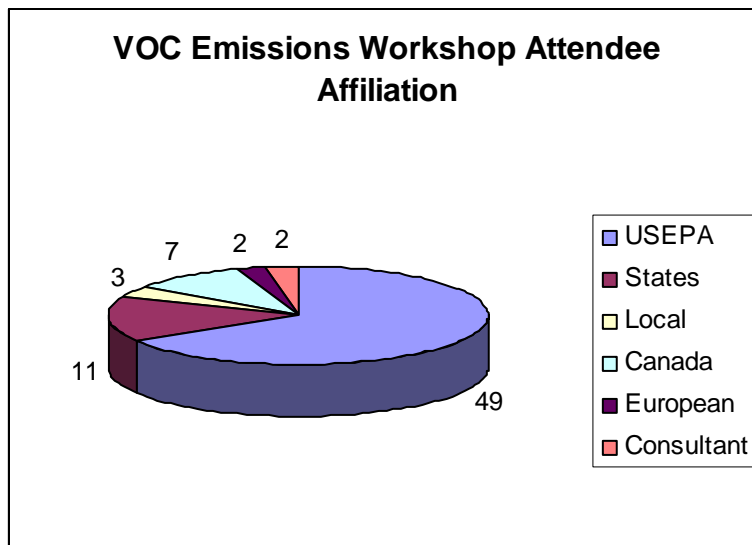

Appendix C: PowerPoint™ Presentations

The Science of Measurement
Fugitive VOC Emissions
Dr. Ram Hashmonay, ARCADIS



JANUARY 1992
VOLUME 42
NUMBER 1

Journal of the
AIR & WASTE
Management Association



Optical remote measurement of toxic gases, 18
EPA's hazardous air pollutant early reduction program, 31
Nitrous oxide emissions from automobiles, 63
Washing a soil contaminated by wood-treating waste, 96
Status of the ADVACATE flue gas desulfurization process, 103

Optical Remote Measurement of Toxic Gases

William B. Grant

NASA Langley Research Center
Hampton, Virginia

Robert H. Kagann

MDA Scientific
Norcross, Georgia

William A. McClenny

US Environmental Protection Agency
Atmospheric Research and Exposure Assessment Laboratory
Research Triangle Park, North Carolina

Enactment of the Clean Air Act Amendments (CAAA) of 1990 has resulted in increased ambient air monitoring needs for industry, some of which may be met efficiently using open-path optical remote sensing techniques. These techniques include Fourier transform spectroscopy, differential optical absorption spectroscopy, laser long-path absorption, differential absorption lidar, and gas cell correlation spectroscopy. With this regulatory impetus, it is an opportune time to consider applying these technologies to the remote and/or path-averaged measurement and monitoring of toxic gases covered by the CAAA. This article reviews the optical remote sensing technology and literature for that application.

Air Toxics Monitoring
**Having Trouble Making
the Pieces Fit?**



Put Them Together With Remote Optical Sensing.

Emission Flux Measurement Phase Diagrams

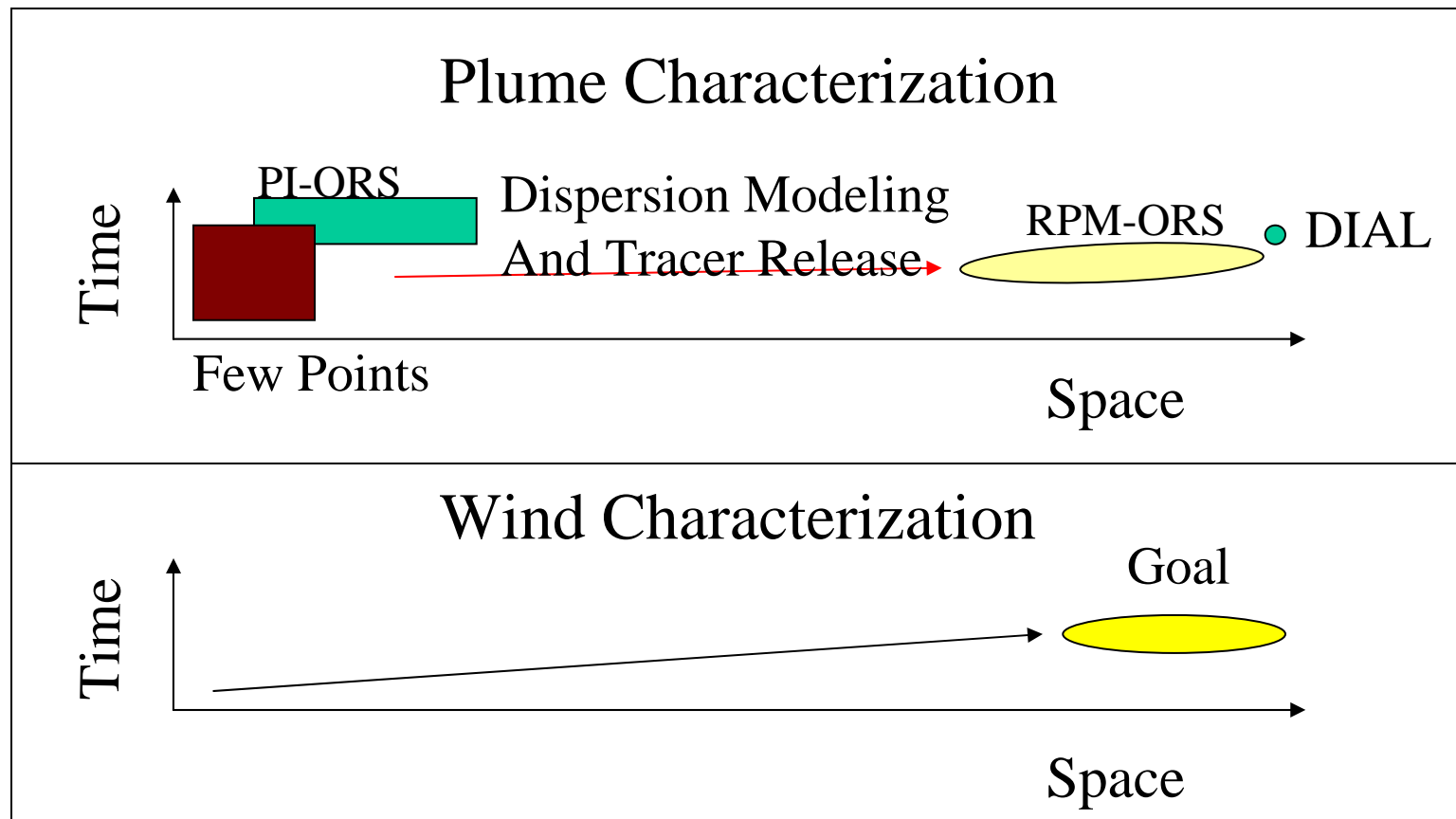

Optical Remote Sensing for Emission Characterization from Non-point Sources

1.0 Scope and Application

1.1 *Introduction.* This protocol provides the user with methodologies for characterizing gaseous emissions from non-point pollutant sources. These methodologies use an open-path, Path-Integrated Optical Remote Sensing (PI-ORS) system in multiple beam configurations to directly identify "hot spots" and measure emission fluxes. Basic knowledge of a PI-ORS system and the ability to obtain quality path-integrated concentration (PIC) data is assumed. The user must be capable of using commercial software to utilize the procedures and algorithms explained in this protocol. The methodologies in this protocol have been well developed, evaluated, demonstrated, validated, and peer-reviewed.¹⁻¹²

NOTE 1 — Any mention of a "PI-ORS system" in this protocol refers to the open-path PI-ORS instrument itself, as well as any associated components used, such as mirrors, scanners, and software.

This protocol does not discuss specific applications (e.g., hog farms, landfills), but provides general guidelines or procedures that can be applied. Detailed protocols for specific applications may be added at a future date.

1.1.1 *Scope.* This protocol currently describes three methodologies, each for a specific use. The Horizontal Radial Plume Mapping (HRPM) methodology was designed to map pollutant concentrations in a horizontal plane. The Vertical Radial Plume Mapping (VRPM) methodology was designed to measure mass flux of pollutants through a vertical plane, downwind from an emission source. The one-dimensional Radial Plume Mapping methodology (1D-RPM) was designed to profile pollutant concentrations along a line-of-sight (e.g., along an industrial site fence line). In future revisions to this protocol, additional PI-ORS emission monitoring methodologies (other than the methodologies described in this protocol) that address non-point sources can be added as validation data are generated.

1.1.2 *Choice of Instrumentation.* The choice of PI-ORS system to be used for the collection of measurement data (and subsequent calculation of PIC) is left to the discretion of the user, and should be dependent on the compounds of interest and the purpose of the study. The methodologies are independent of the particular PI-ORS system used to generate the PIC data. It is recommended for the HRPM, VRPM, and 1D-RPM methodologies that the typical expected concentration over the longer beams should be about 10 times the minimum detection limit of the instrument. When this is not the case, the user should replace nondetects with values of half the minimum detection limit (see Table A.3 in the Appendix A).

USEPA OTM-10

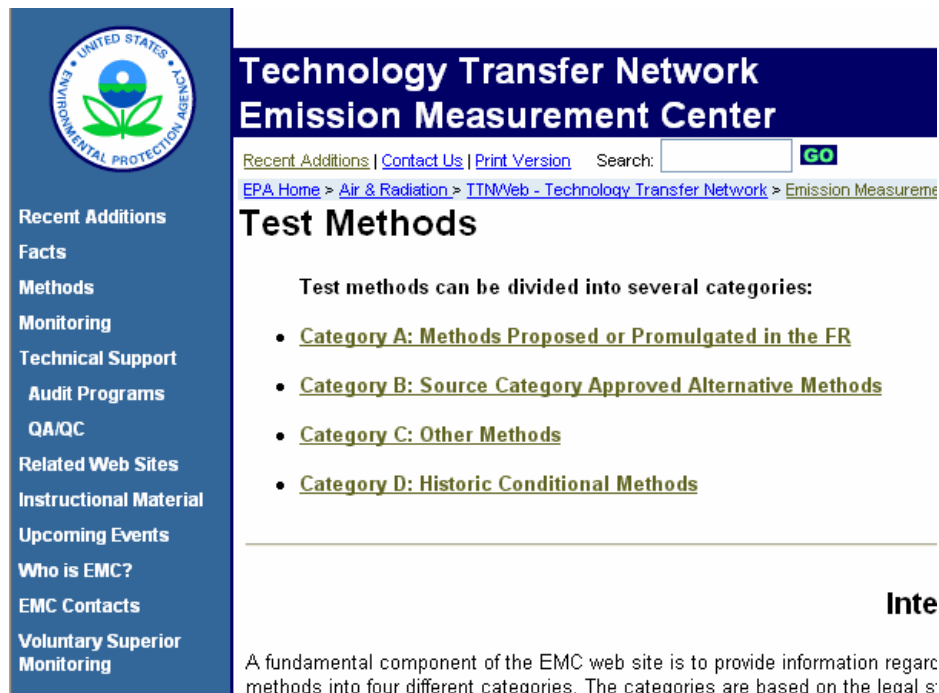

**Technology Transfer Network
Emission Measurement Center**

[Recent Additions](#) | [Contact Us](#) | [Print Version](#) Search: **GO**

[EPA Home](#) > [Air & Radiation](#) > [TTNWeb - Technology Transfer Network](#) > [Emission Measurement Center](#)

Test Methods

Test methods can be divided into several categories:

- [Category A: Methods Proposed or Promulgated in the FR](#)
- [Category B: Source Category Approved Alternative Methods](#)
- [Category C: Other Methods](#)
- [Category D: Historic Conditional Methods](#)

Inte

A fundamental component of the EMC web site is to provide information regarding test methods into four different categories. The categories are based on the legal s

6.0 Equipment and Supplies

6.1 *Instrumentation.* Any scanning PI-ORS system that can provide PIC data may be considered for the purposes of the methodologies described in this protocol, and may include the following:

Open-Path Fourier Transform Infrared (OP-FTIR) Spectroscopy

Ultra-Violet Differential Optical Absorption Spectroscopy (UV-DOAS)

Open-Path Tunable Diode Laser Absorption Spectroscopy (TDLAS)

Path-Integrated Differential Absorption LIDAR* (PI-DIAL)

* LIDAR – Light Detection and Ranging

Applications

- U.S. EPA Landfill Studies
- U.S. EPA CAFO Studies
- U.S. EPA Superfund and Brownfield Sites
- U.S. EPA Homeland Security Research
- U.S. EPA Diesel and Jet Engine Emission study
- U.S. EPA RPM protocol (DOD ESTCP Demonstration)
- U.S. EPA Chlor-Alkali elemental mercury emissions
- U.S. EPA Gas Station Emissions
- FL DAQ and LDEQ: HF emissions from phosphate industries
- ODEQ: OP-FTIR Study of Industrial Emissions
- NMED: OP-FTIR Study of Industrial Emissions

Using DIAL to Measure VOC
Fugitive Emissions
Allan Chambers, Alberta
Research Council, Inc.



Using DIAL to Measure Fugitive Emissions of Hydrocarbons

Allan Chambers, P. Eng.
Alberta Research Council Inc.

www.arc.ab.ca

VOC Fugitive Losses Workshop, October 25, 2006

Objectives of this project

- demonstrate new optical methods to:
 - measure and quantify fugitive emissions of hydrocarbons
 - locate leaks
 - ultimately reduce fugitive emissions
- compare measured emissions with estimated emissions

DIAL Surveys completed in Alberta



- gas processing plants (2 sweet, 4 sour)
- refinery

- tar sands mining and separation facility
- bitumen upgrader
- flares (combustion efficiency)

Optical Methods

- Differential Absorption Light Detection and Ranging (DIAL)
 - laser-based, remote measurement of gas concentration
 - quantify hydrocarbons in emission plume
- gas leak imaging camera
 - video identification of hydrocarbon leaks

DIAL (www.spectrasyne.ltd.uk)

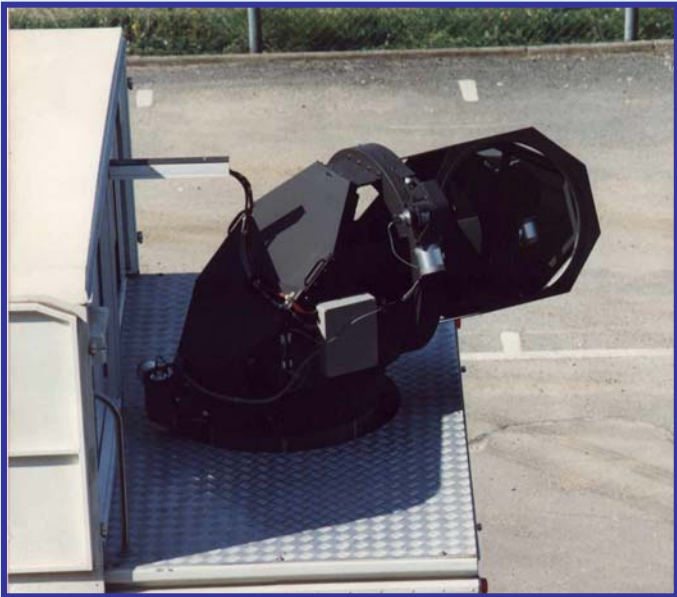

- scanning telescope
- onboard weather station



DIAL Measurement of Fugitives

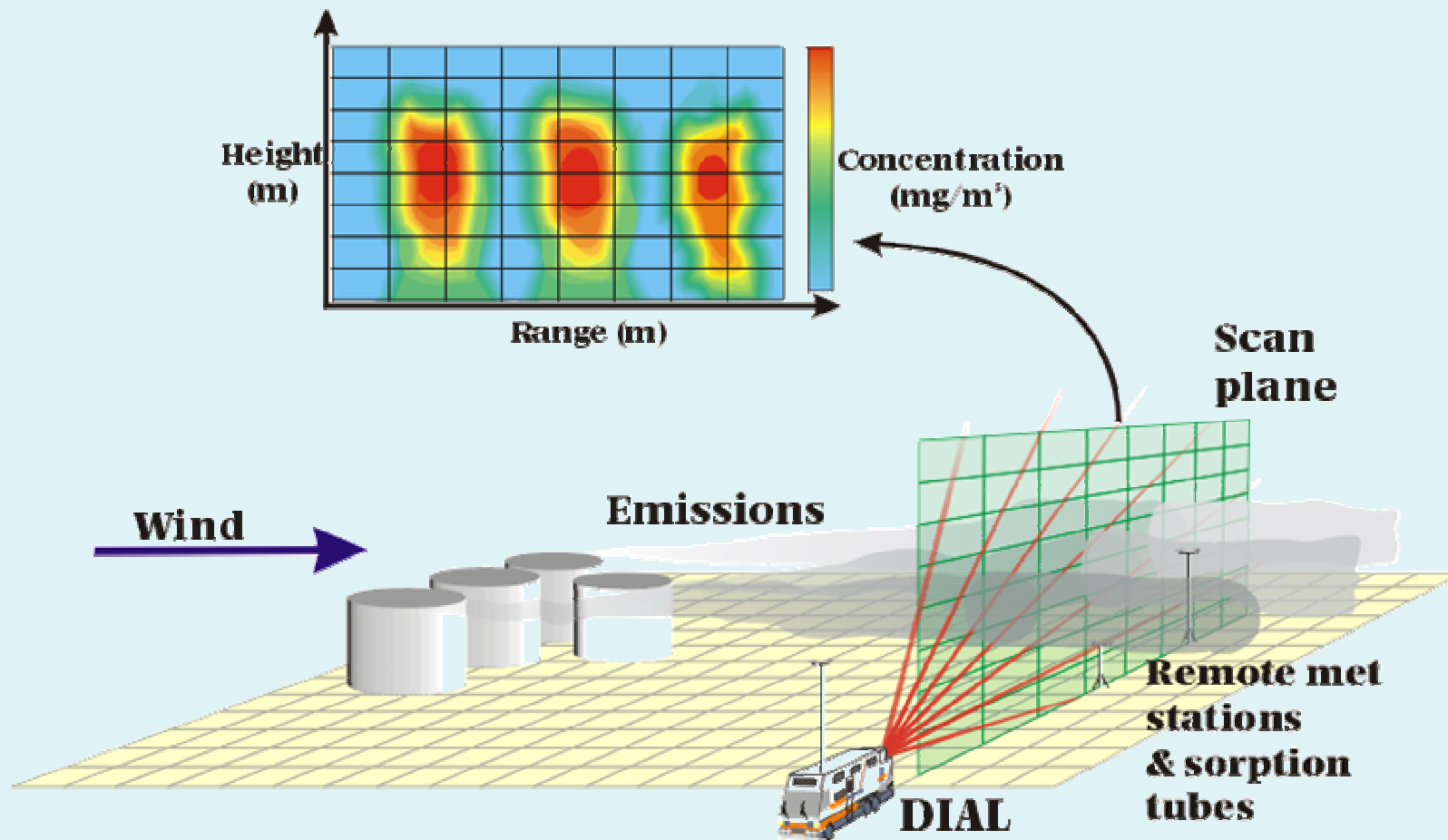

SO₂ Plume from Stack

plume
cross section
300 m
downwind

stack height

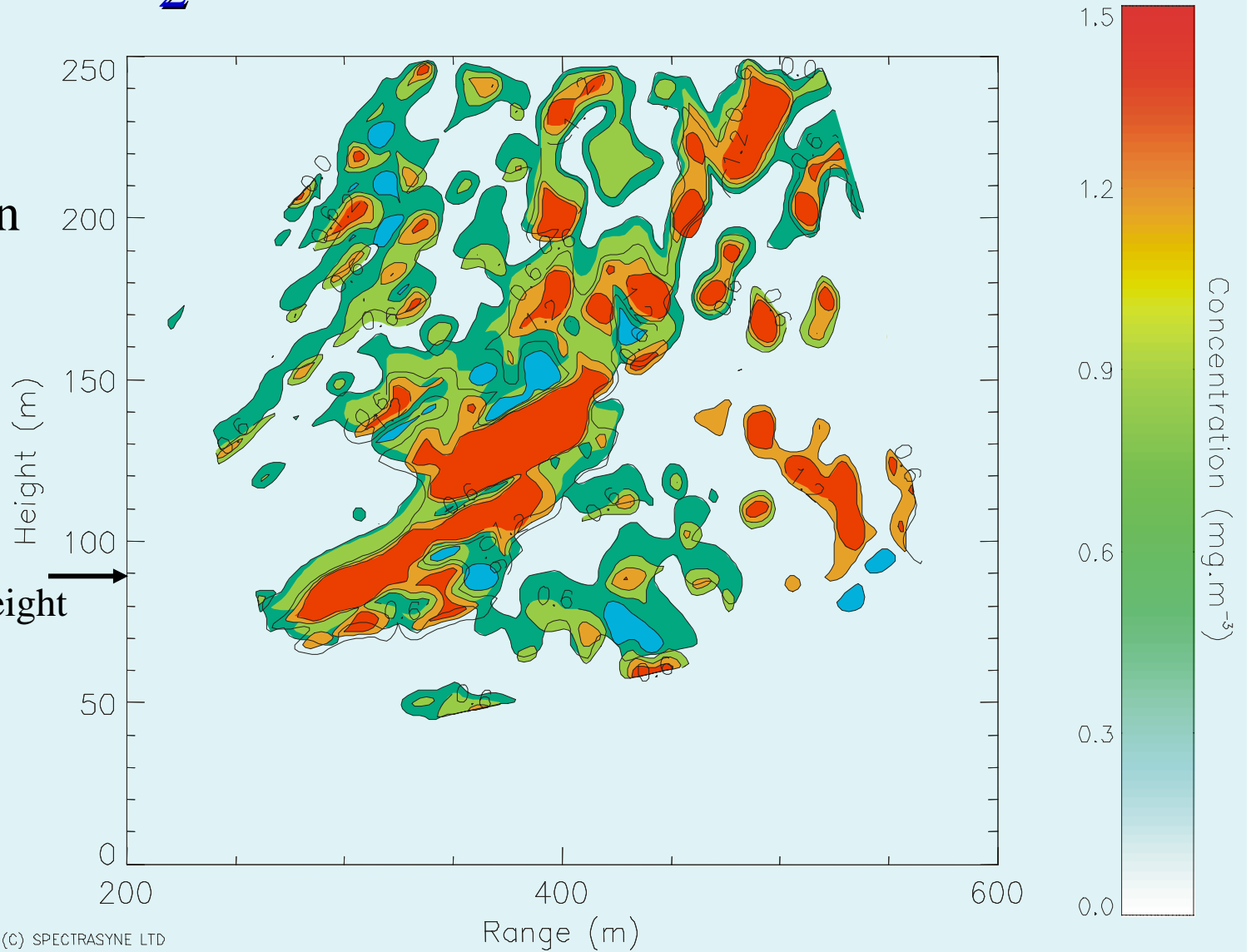

Validation of Spectrasyne's DIAL

- in Europe:
 - six validation studies with hydrocarbons
 - DIAL mass emissions within -3 to -12%
- in Alberta:

Source	Stack Monitor (kg/h)	DIAL (kg/h)	delta (%)
SO ₂ from incinerator	340	304	-11
NO from gas turbine	66.5	67.1	+1

DIAL Surveys at Alberta Gas Plants

Plant	CH ₄ Emissions (kg/hr)	C ₂₊ Emissions (kg/hr)	Benzene (kg/hr)
A	-	38	-
B	104 (450*)	42	-
C	146	342	-
D	124	86	-
E	144	41	0.06
F	77	102	

* reflects leaking pressure relief valve

- process flares account for 10 to 15% of CH₄ emission

- 100 kg/hr equals \$270,000/yr at \$6/GJ

Allocating Emissions – Sweet Gas Plant

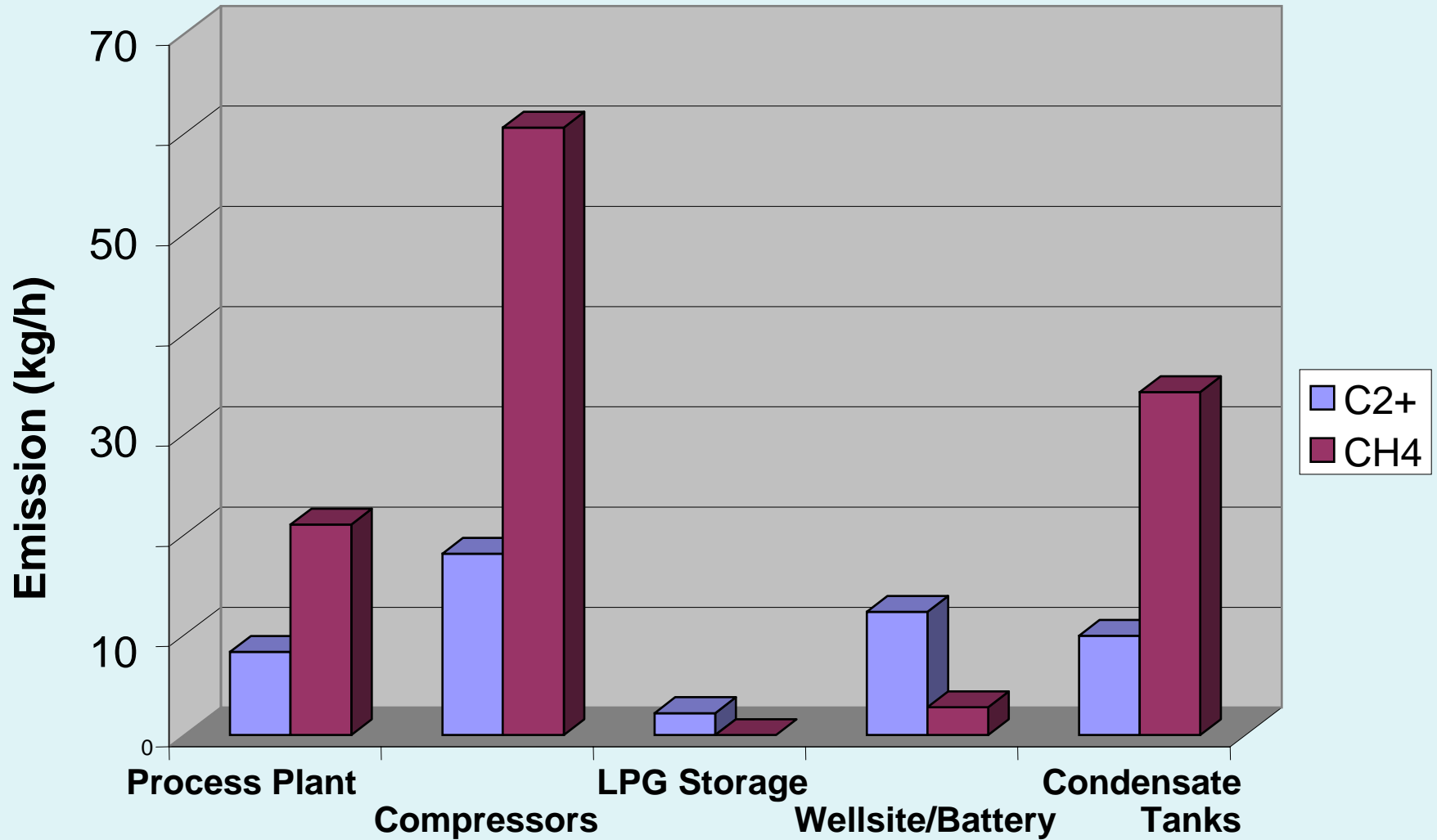

Alberta Refinery Survey

- DIAL survey to quantify emissions of:
 - CH₄
 - C₂₊ hydrocarbons (alkanes)
 - benzene
- 140,000 bbl/day refinery
- 10 days of DIAL measurement
- 5 days of leak imaging camera survey
- no upsets during survey period

DIAL Measured C₂₊ (VOC) - refinery

Area	C ₂₊ (kg/h)	% of total
coker + vacuum unit	211.5	17.1
new process area	68.3	5.5
old process area	161.8	13.1
cooling towers	164	13.2
feed tanks	141	11.4
intermediate tanks	68.7	5.6
product tanks	277	22.4
new tanks	137	11.1
bullets and spheres	7.4	0.6
Site total	1237	

Example C₂₊ Scans – Cooling Towers

Aug. 31:

C₂₊ = 158 kg/h

Sep. 13:

C₂₊ = 170 kg/h

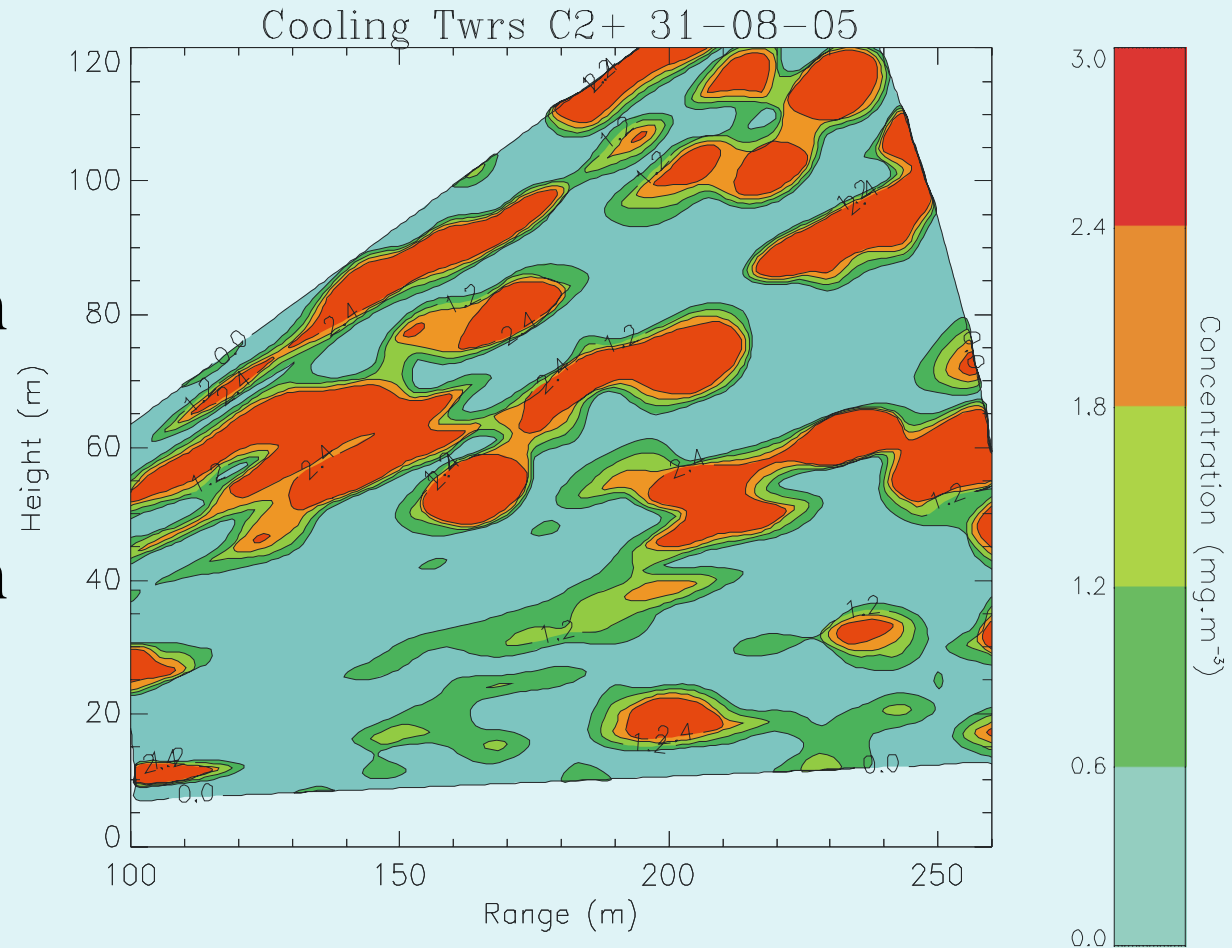

DIAL Measured CH₄

Area	CH ₄ (kg/h)	% of total
coker + vacuum unit	125	41.7
new process area	44.8	14.9
old process area	65.2	21.7
cooling towers	26.1	8.7
feed tanks	18.4	6.1
intermediate tanks, product tanks	-	-
new tanks	20.6	6.9
bullets and spheres	-	-
Site total	300.1	

DIAL Measured Benzene

Area	Benzene (kg/h)	% of total
coker + vacuum unit	1.34	27
new process area	0.25	5
old process area	0.23	5
crude feed tanks	0.67	13.5
intermediate tanks	0.57	11.5
product tanks	1.30	26
new tanks	0.61	12
Site total	4.97	

Observations from DIAL Survey

- coker area was large source of emissions
 - methane (41%)
 - VOCs (17%)
 - benzene (27%)
- product tanks were a large source
 - VOC (22%)
 - benzene (26%)
- cooling towers an unexpected source of VOC emissions (13%)

Comparison of Refinery Estimated and Measured Fugitive Emissions

- assumptions:
 - DIAL short term measurements represent average annual emissions
 - assumed 48 week operation (8,064 hours)
 - C₂₊ measurement represents VOCs
- emission factor estimates as submitted to the National Pollutant Release Inventory (based on API methods)

Refinery VOC Emissions

	Emission Factor Estimates (tonnes/y)	DIAL C₂₊ Measurements (tonnes/y)
stack or point release	98.69	not measured
storage or handling	153.0	5,090
fugitive releases	407.1	4,880
spills	11.5	not measured
Total	670.4	9,970

Refinery Benzene Emissions

	Emission Factor Estimates (tonnes/y)	DIAL Benzene Measurements (tonnes/y)
stack or point release	0.039	not measured
storage or handling	0.265	25.4
fugitive releases	1.850	14.7
spills	0.061	not measured
Total	2.215	40.1

Refinery Measured vs. Estimates

- tanks are a much larger portion of both VOC and benzene emissions than estimates suggest
- measured VOC emissions were 15 fold higher than estimates
- measured benzene emissions were 18 fold higher
- measured losses ~\$ 3 million/yr

Emissions, European Refineries

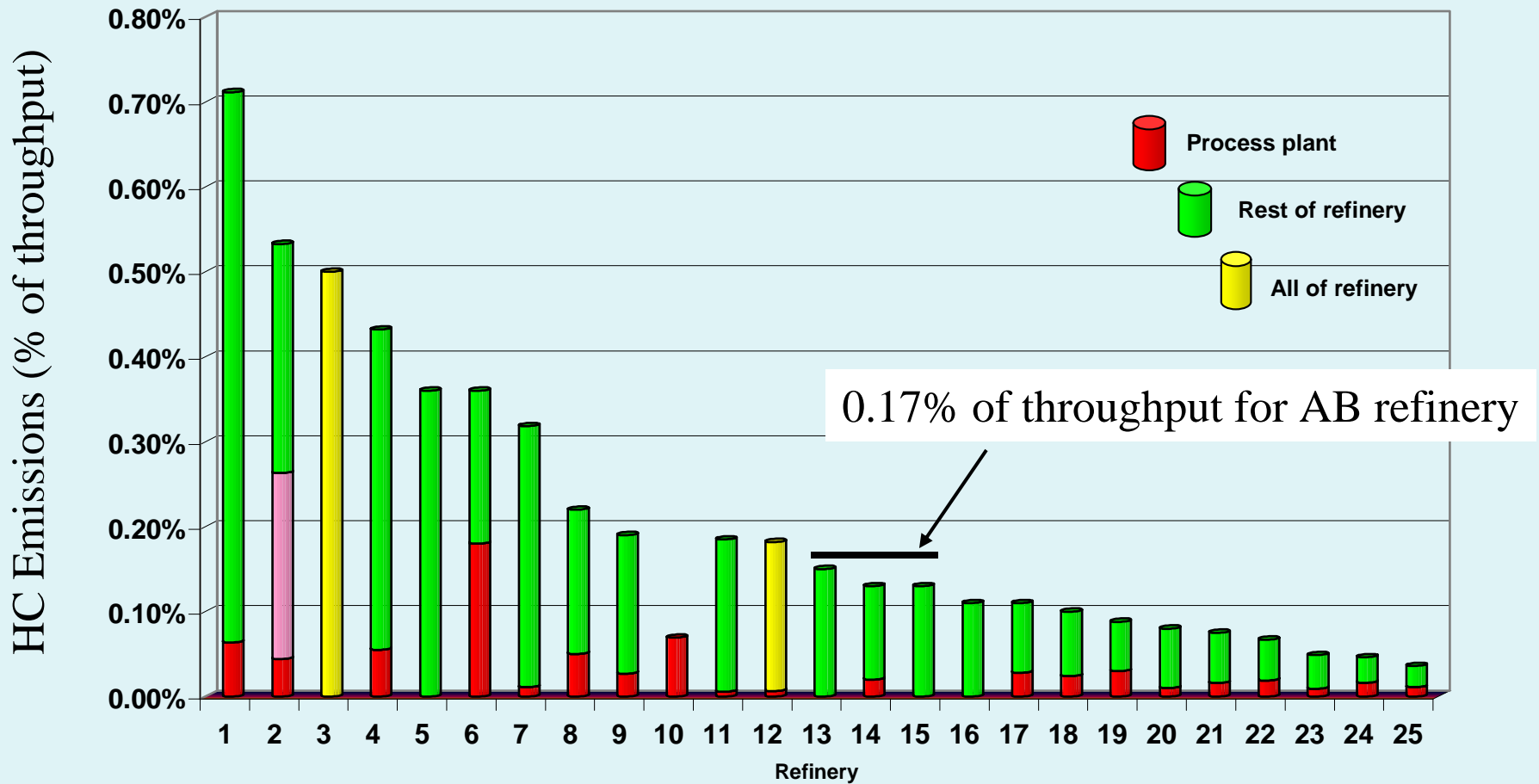

Reducing Fugitive Emissions



2005 FLIR gas leak imaging camera

- refinery survey by Leak Surveys Inc., Texas
- visual indication of hydrocarbon leak, no quantification

Emissions Reduction at Gas Plant C

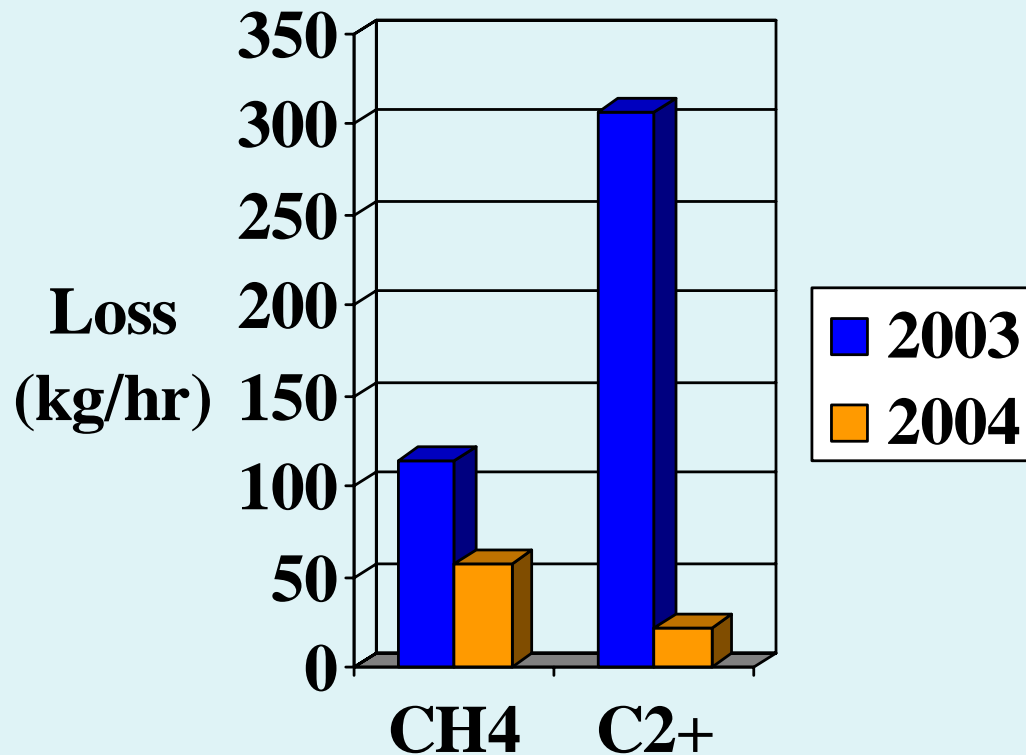

- gas leak imaging to find leaks, most repaired
- DIAL to quantify emissions
- over 90% reduction in C₂₊ losses in 1 year

Project Conclusions

- DIAL can quantify fugitive emissions and focus leak repair efforts
- DIAL measurements were significantly higher than emissions estimates
- storage tanks and flares were larger sources than indicated by estimation methods
- potential to recover significant \$'s of product currently lost to atmosphere

Acknowledgements



- gas plant surveys funded by:
 - Canadian Association of Petroleum Producers (CAPP)
 - Environment Canada
 - British Columbia Oil and Gas Commission
- refinery survey funded by:
 - Environment Canada
 - Ontario Ministry of Environment
 - Alberta Environment

Final Reports from DIAL Studies



- www.arc.ab.ca/Index.aspx/ARC/8300

Radial Plume Mapping
Bruce Harris, Office of Research
and Development, EPA

Optical Remote Sensing for Characterizing Non-Point Source Emissions

D. Bruce Harris

Air Pollution Prevention and Control Division
National Risk Management Research Laboratory
Office of Research and Development
U. S. Environmental Protection Agency
Research Triangle Park, NC

Optical Remote Sensing for Emission Characterization from Non-point Sources

1.0 Scope and Application

1.1 *Introduction.* This protocol provides the user with methodologies for characterizing gaseous emissions from non-point pollutant sources. These methodologies use an open-path, Path-Integrated Optical Remote Sensing (PI-ORS) system in multiple beam configurations to directly identify "hot spots" and measure emission fluxes. Basic knowledge of a PI-ORS system and the ability to obtain quality path-integrated concentration (PIC) data is assumed. The user must be capable of using commercial software to utilize the procedures and algorithms explained in this protocol. The methodologies in this protocol have been well developed, evaluated, demonstrated, validated, and peer-reviewed.¹⁻¹²

NOTE 1 — Any mention of a "PI-ORS system" in this protocol refers to the open-path PI-ORS instrument itself, as well as any associated components used, such as mirrors, scanners, and software.

This protocol does not discuss specific applications (e.g., hog farms, landfills), but provides general guidelines or procedures that can be applied. Detailed protocols for specific applications may be added at a future date.

1.1.1 *Scope.* This protocol currently describes three methodologies, each for a specific use. The Horizontal Radial Plume Mapping (HRPM) methodology was designed to map pollutant concentrations in a horizontal plane. The Vertical Radial Plume Mapping (VRPM) methodology was designed to measure mass flux of pollutants through a vertical plane, downwind from an emission source. The one-dimensional Radial Plume Mapping methodology (1D-RPM) was designed to profile pollutant concentrations along a line-of-sight (e.g., along an industrial site fence line). In future revisions to this protocol, additional PI-ORS emission monitoring methodologies (other than the methodologies described in this protocol) that address non-point sources can be added as validation data are generated.

1.1.2 *Choice of Instrumentation.* The choice of PI-ORS system to be used for the collection of measurement data (and subsequent calculation of PIC) is left to the discretion of the user, and should be dependent on the compounds of interest and the purpose of the study. The methodologies are independent of the particular PI-ORS system used to generate the PIC data. It is recommended for the HRPM, VRPM, and 1D-RPM methodologies that the typical expected concentration over the longer beams should be about 10 times the minimum detection limit of the instrument. When this is not the case, the user should replace nondetects with values of half the minimum detection limit (see Table A.3 in the Appendix A).

USEPA OTM-10

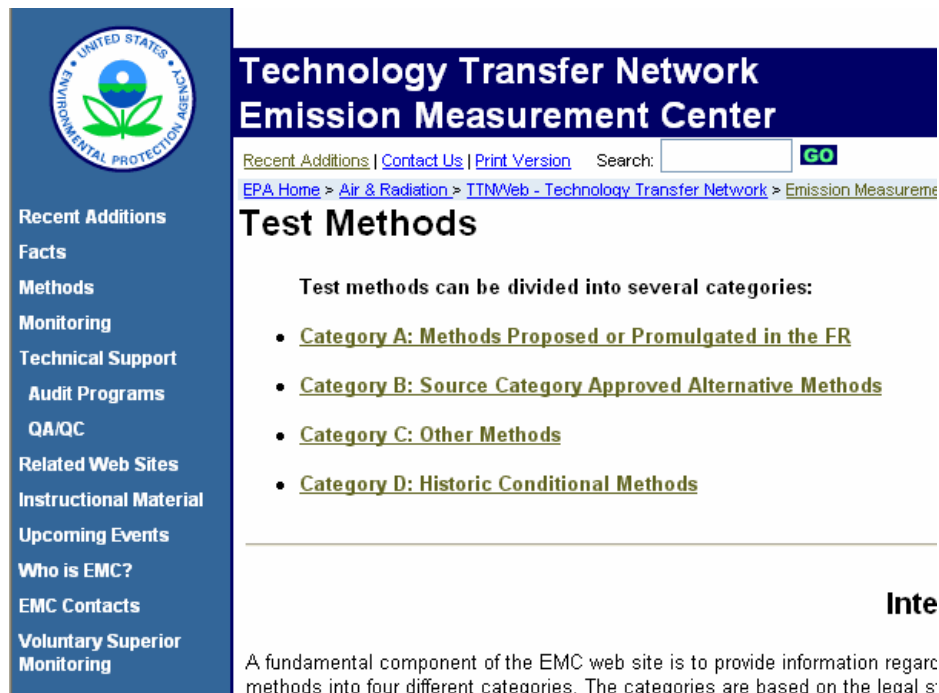

**Technology Transfer Network
Emission Measurement Center**

Recent Additions | Contact Us | Print Version Search: **GO**

[EPA Home](#) > [Air & Radiation](#) > [TTNWeb - Technology Transfer Network](#) > [Emission Measurement Center](#)

Test Methods

Test methods can be divided into several categories:

- [Category A: Methods Proposed or Promulgated in the FR](#)
- [Category B: Source Category Approved Alternative Methods](#)
- [Category C: Other Methods](#)
- [Category D: Historic Conditional Methods](#)

Inte

A fundamental component of the EMC web site is to provide information regarding test methods into four different categories. The categories are based on the legal s

Applications of ORS Instrumentation

- OP-FTIR
 - VOCs, CH₄, NH₃
 - Large Organics
 - PM
 - Multiple Compounds Simultaneously
- Tunable Diode Lasers (TDL)
 - H₂S, C₂H₄, C₂H₂, CH₄, NH₃, CO, CO₂, and more
 - Single Compound
- UV-DOAS
 - H₂S, Hg, BTEX & more
- DIAL
 - Long range

Example of MDLs for OP-FTIR

Air Toxic Name	Formula	MDL (ppb)
Acrylonitrile	CH ₂ =CH-C=N	7
Carbon tetrachloride	CCl ₄	1
Chloroform	CHCl ₃	1
Ethylene dibromide, 1,2-dibromoethane	BrCH ₂ CH ₂ Br	3
Propylene trichloride	1,2,3-trichloropropane	8
1,3-dichloropropene		13
Ethylene dichloride	ClCH ₂ CH ₂ Cl	18
Ethylene oxide	CH ₂ CH ₂ O	10
Hydrazine		8
Methylene chloride	CH ₂ Cl ₂	5
Quinoline		6
1,1,2,2-tetrachloroethane		4
Perchloroethylene	C ₂ Cl ₄	1
Trichloroethylene	C ₂ HCl ₃	2
Vinyl chloride	C ₂ H ₃ Cl	4

OP-FTIR and TDL On-Site



VRPM to Measure Emissions Fluxes from Area or Fugitive Sources

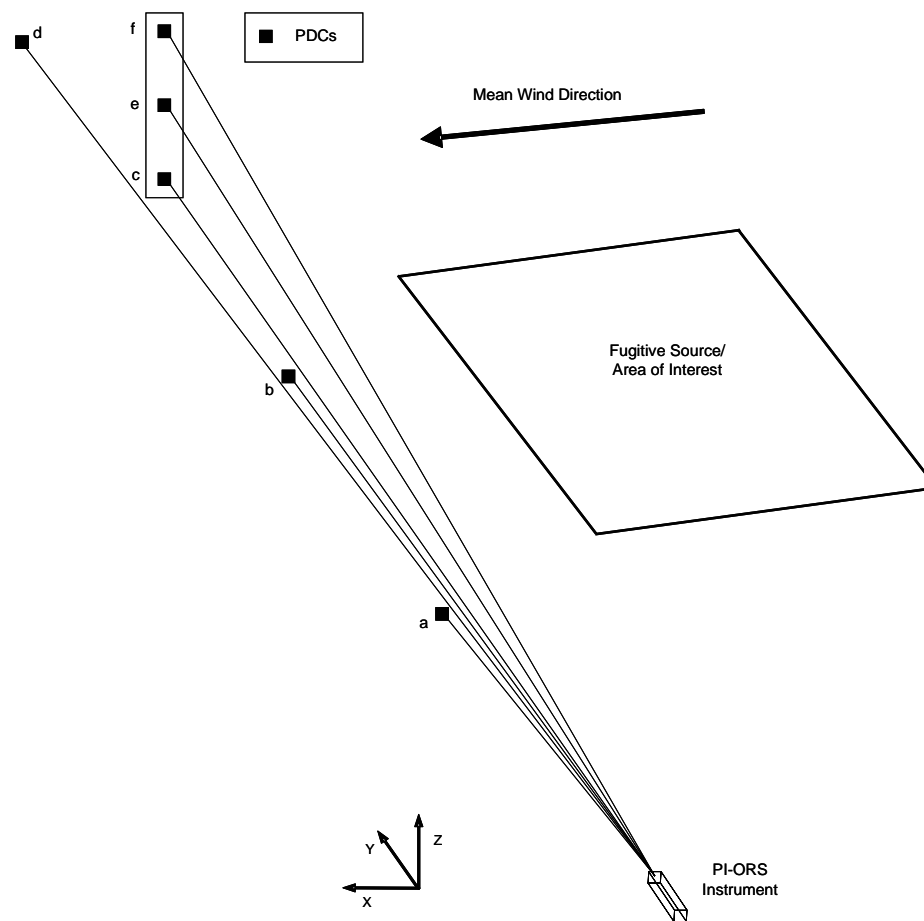

VRPM Configuration at a GDF Facility



Gasoline Vapor Measured at Site (blue trace) to Synthetic Reference Spectrum Created Using a Composite of Four Compounds

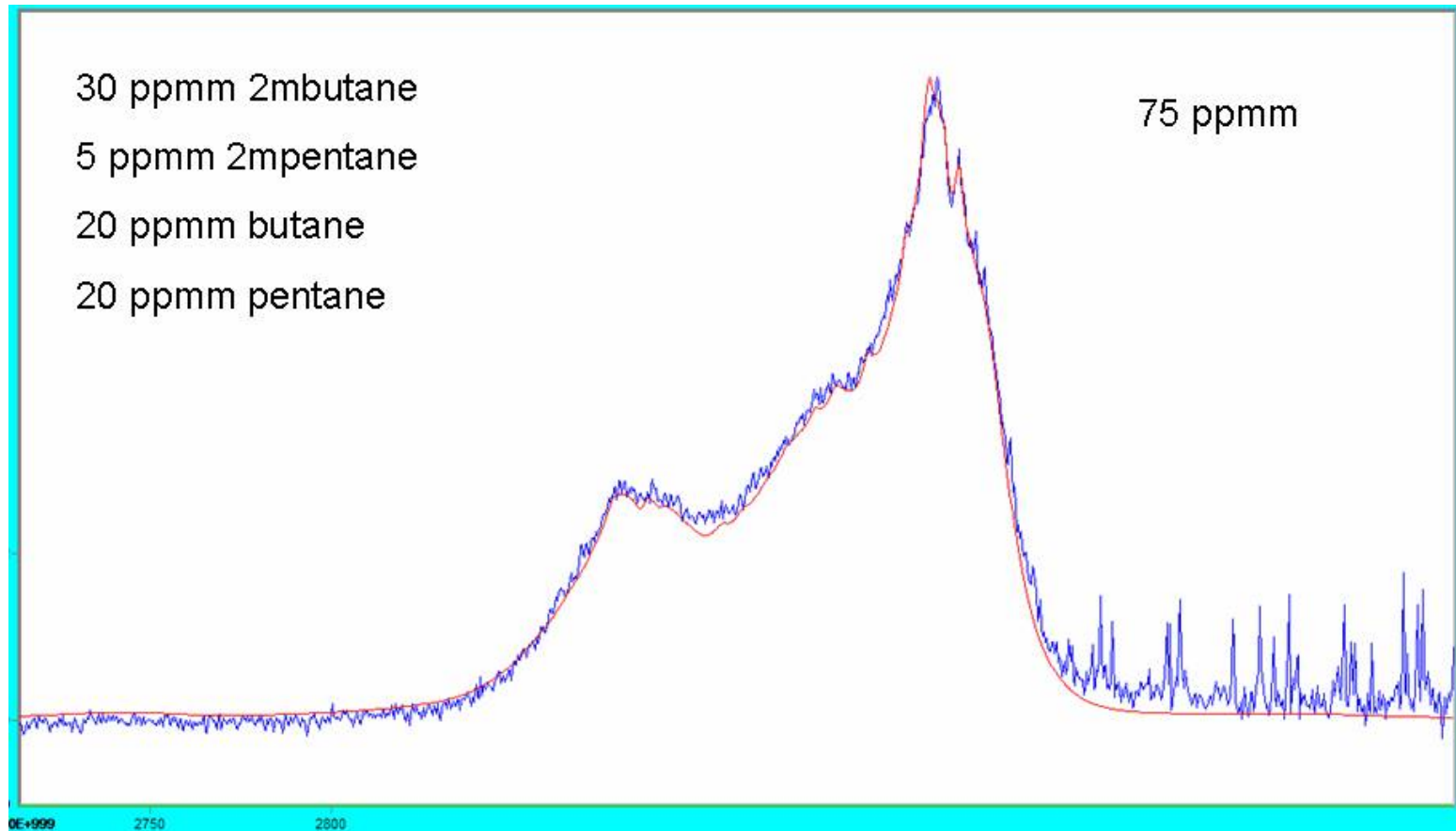

Gasoline Vapor from Sample Measured in Gas Cell with Volume Ratio of Components to Aliphatic Mix

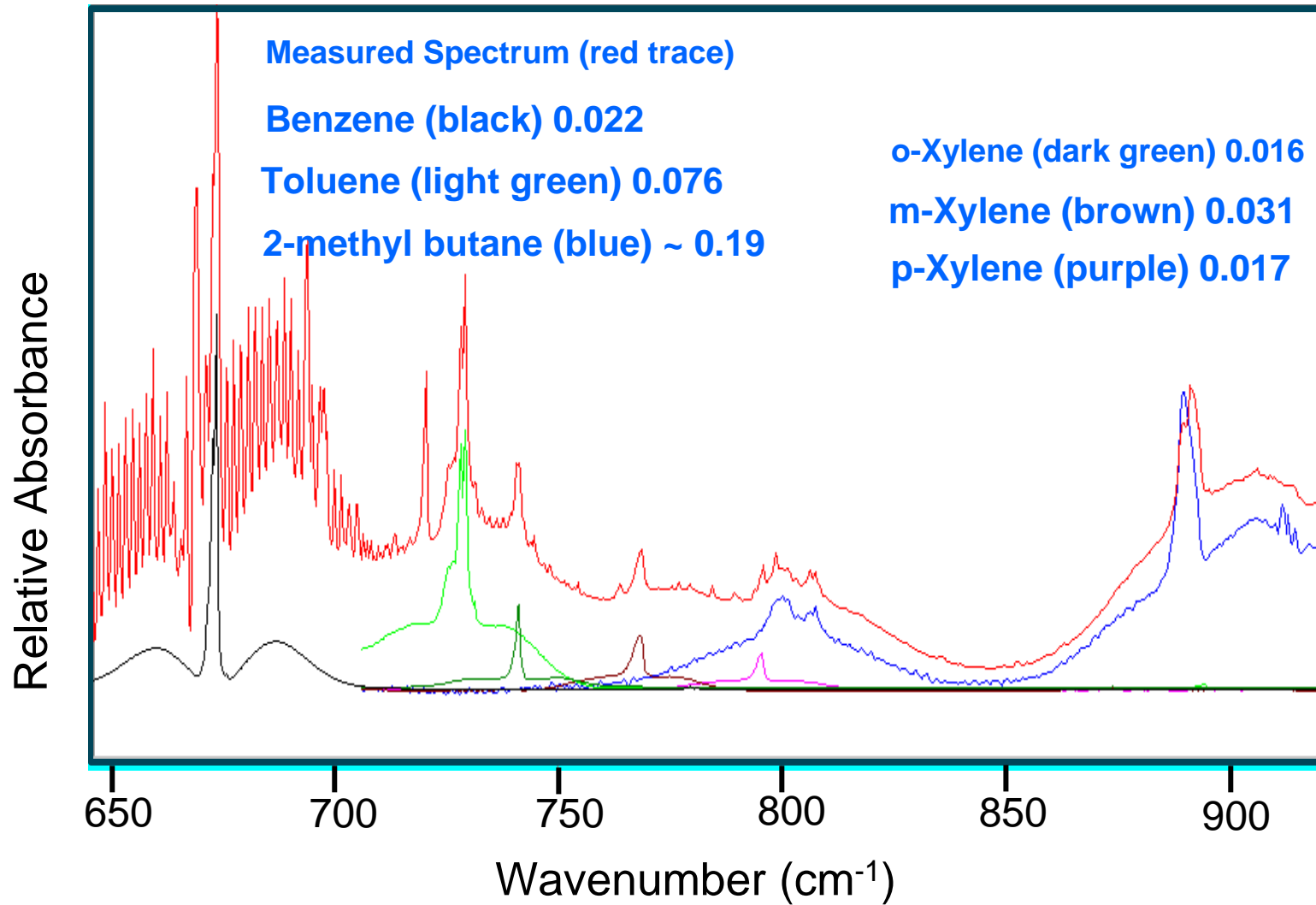

Costco Gas Station Gasoline Emissions

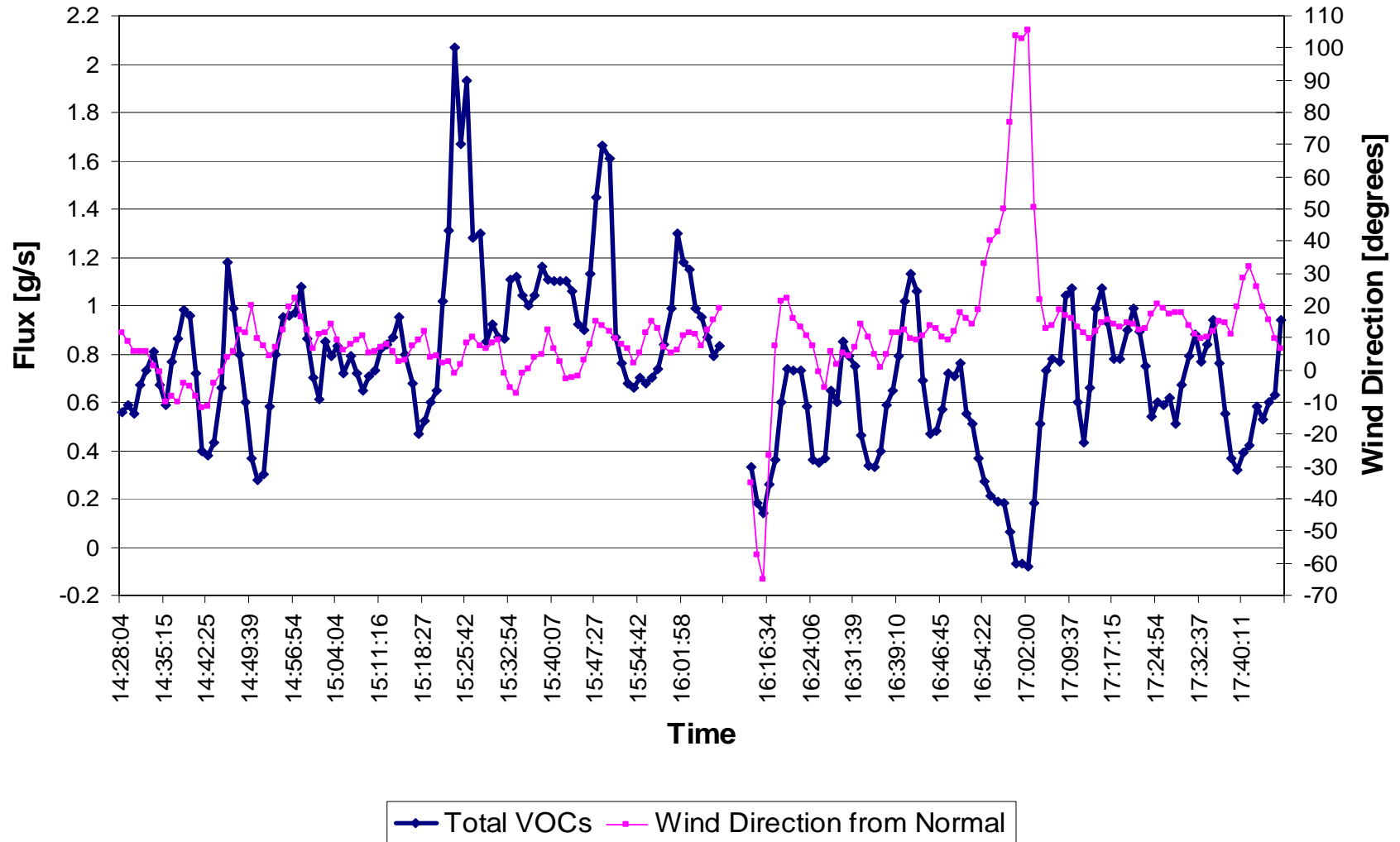

UV-DOAS VRPM at Industrial Hg Site

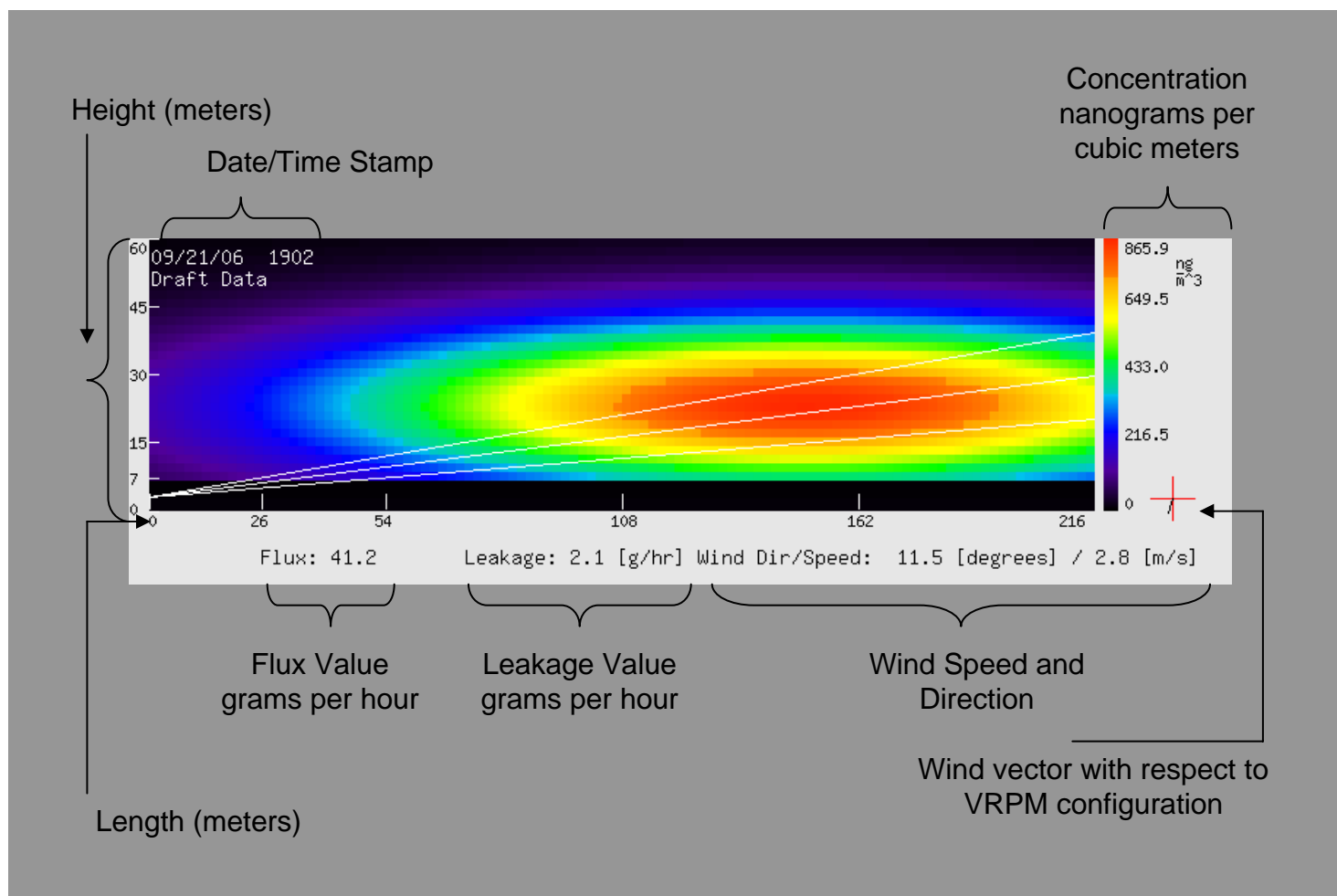

Sampling Strategy

Sampling strategy will combine dual beam open path IR and UV-VIS instruments with a micro pulse LIDAR to measure PM flux

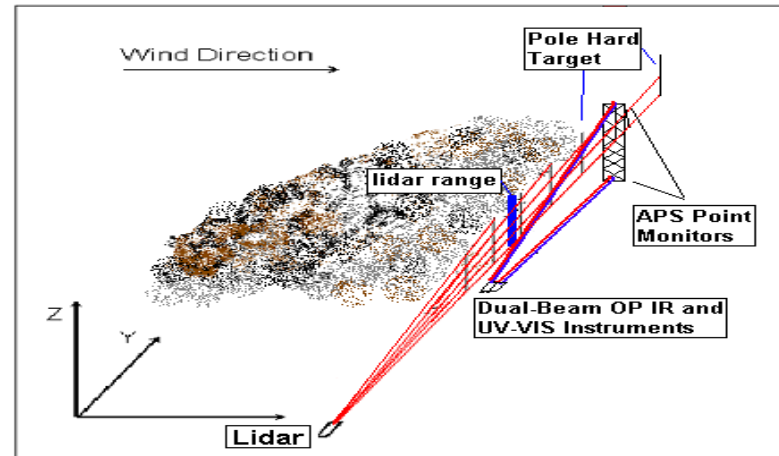
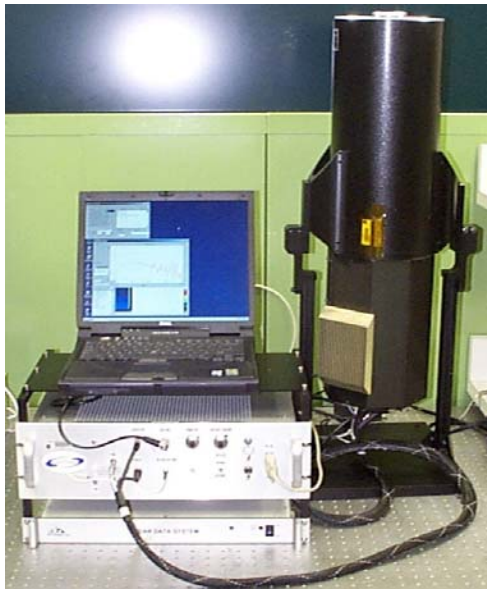

PM10 Calibration Time Series

DT
ORS

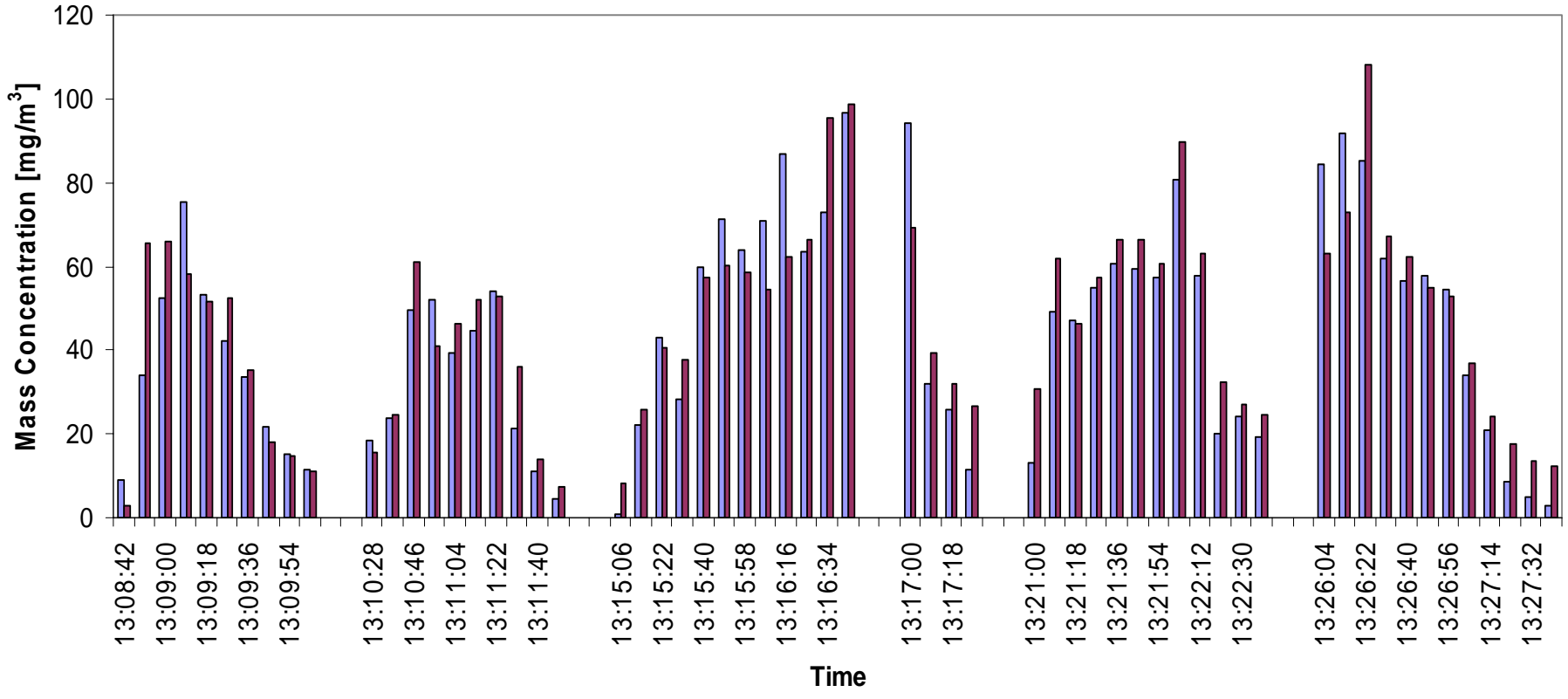

HRPM to Map Emissions from an Area Source

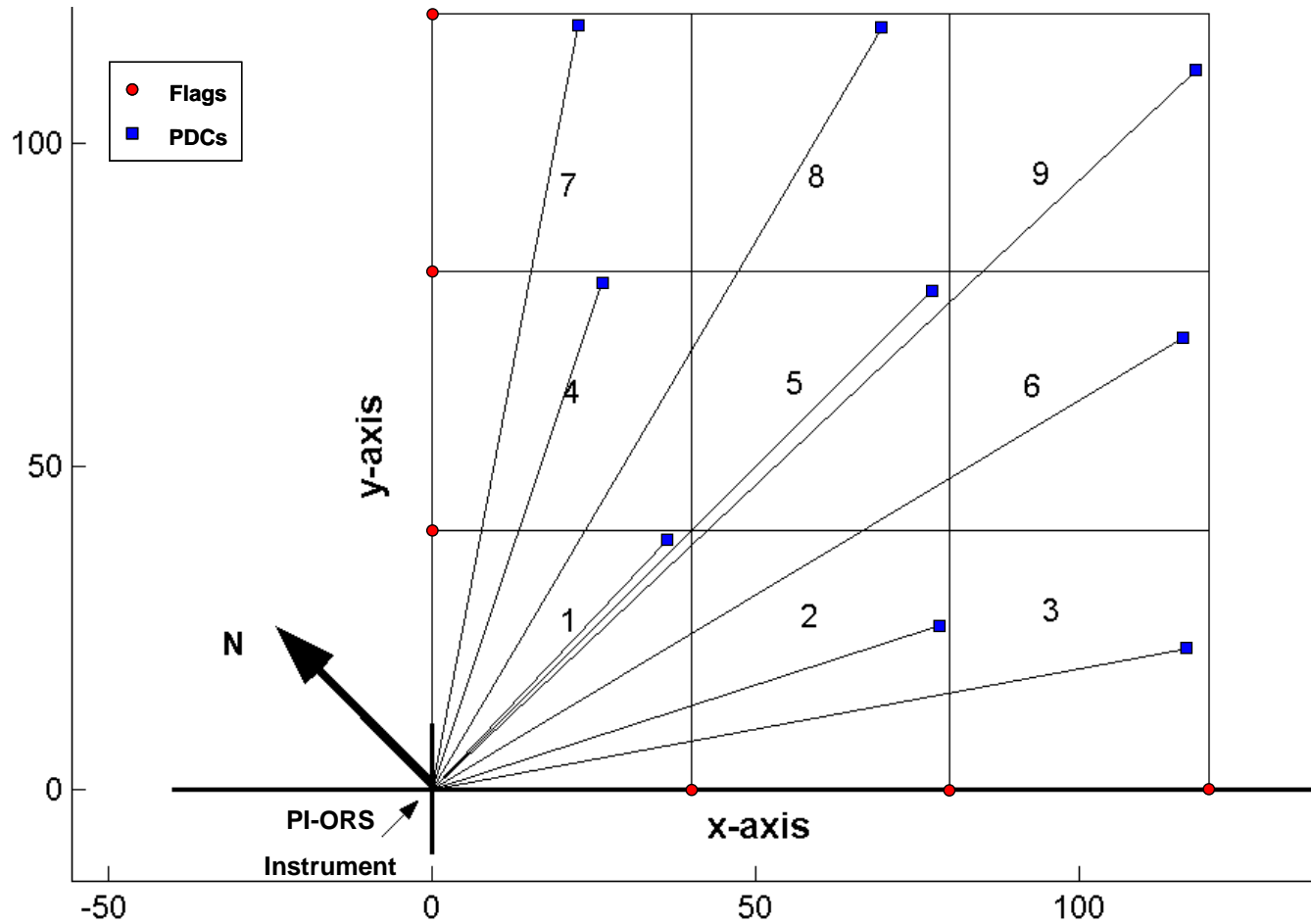

HRPM



EMRPM for 2-D GEOMETRY V3.5

Gas Concentrations |
 RPM Output |
 VRPM Flux time series |
 Reprocess |
 AlarmSet

RPM On |
 HRPM |
 Methane 1000 |
 # of cycles/group 3 |
 CCF 0.995459

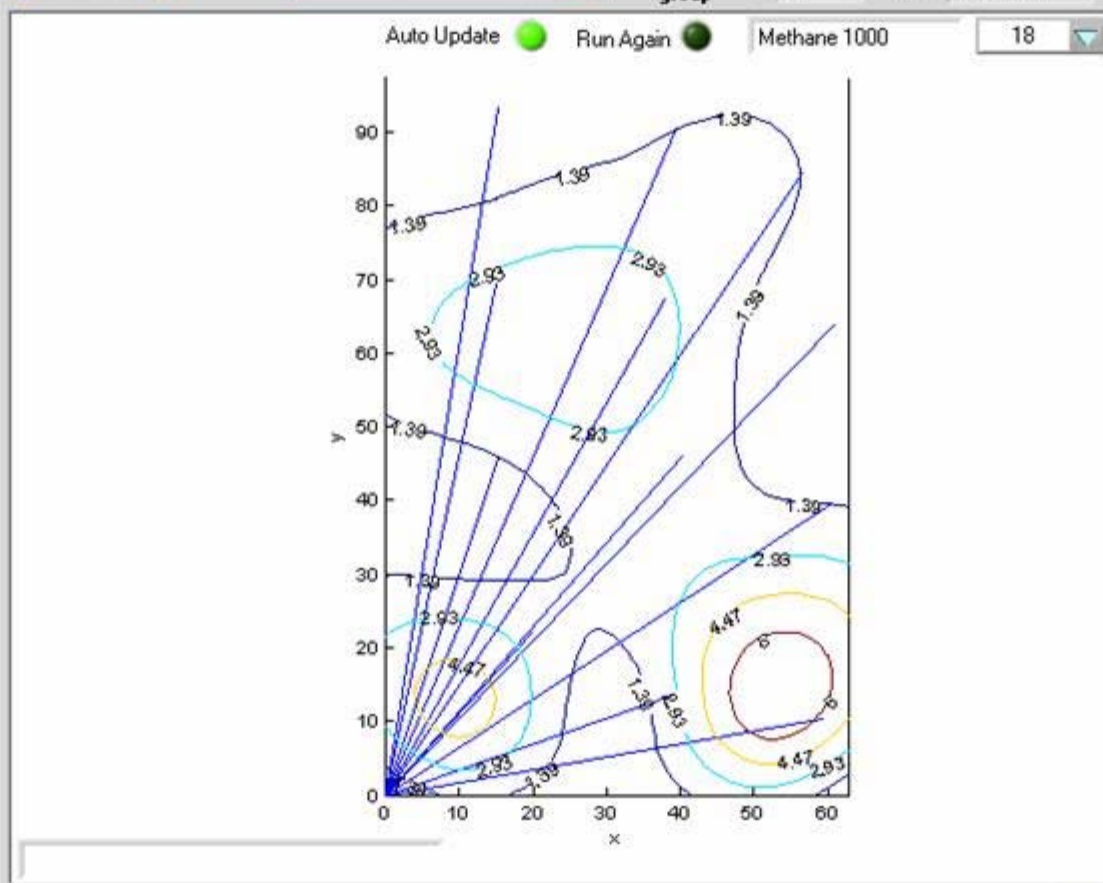

Background Subtraction? Value (PPM) 1.7 Save all Figures as JPEG? Figure color in gray scale? # of Contour lines 4
 Wait time (milli-sec) for RPM auto update 2000 Contour Round off Factor 100

Run Mode From File

Scanner Comm Port ASRL1

Load Param **Mirror #1**

Add One Mirror Enter New Values

Delete Selected Mirror

Mirror Range [m] 0

Mirror Az [deg.min] 0

Mirror El [deg.min] 0

OP-FTIR Bench Gain 1

Scanner Az 0 Get Az and El

Scanner El 0

Set and Save Parameters

Align mode? Align gain 1 Move Scanner

Param Path D:\OrangeCat\05\0005\HRPM\demo.txt

Interferogram Peak-to-Peak V 0

Collection % Complete 0

VRPM Parameters

Molecular Weight 16

Lower angle limit 360

Upper angle limit 0

Angle from N for Mirror on tower 0

of Vertical Wind Levels 12

Wind from Right of

Mean YD from normal 16

Flux Roundoff Factor 100

Contour Values Specified?

Contour Values 0 0.00

HRPM Parameters

Current Cycle# 19 Current Mirror# 1

Save Configuration

Angle of x-axis from North (deg.min) 26

Length of x-axis (m) 63.00

Length of y-axis (m) 97.50

of pixels in x 3 Setup

of pixels in y 4 OFF

Remove Beams?

Remove Pixels?

Scale Figure?

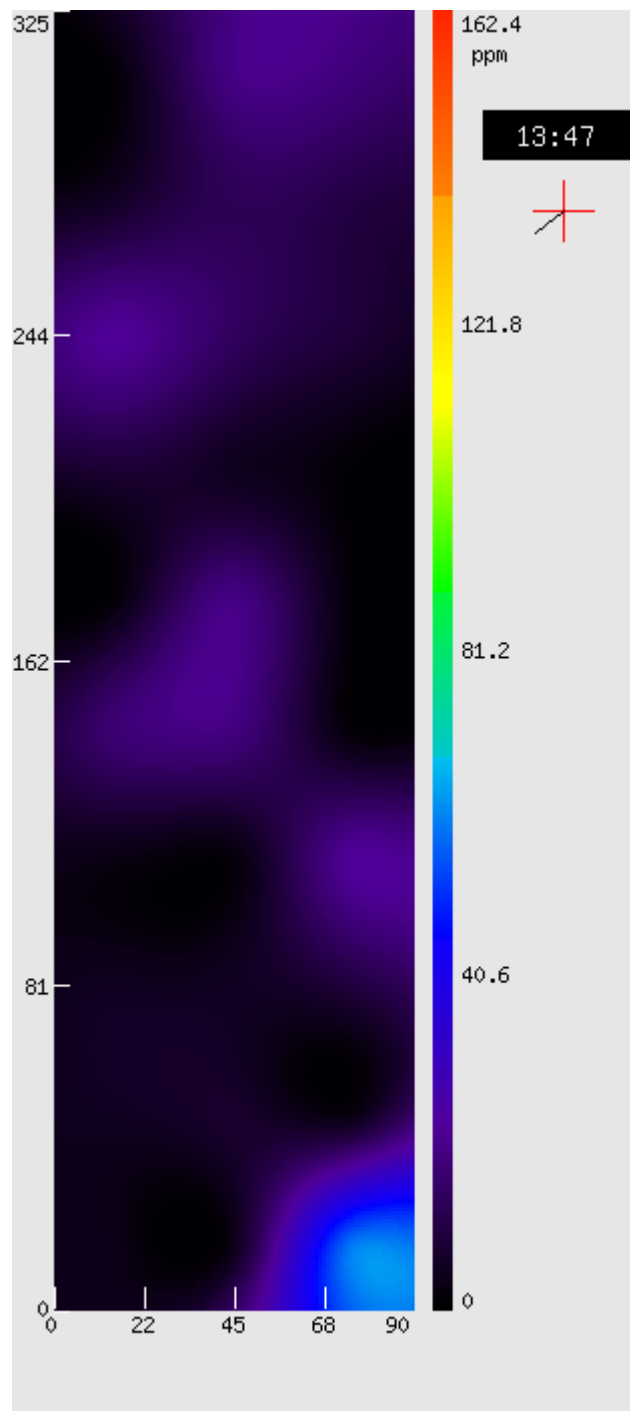

EMRPM for 2-D GEOMETRY V3.5

Run Mode From File

Scanner Comm Port

Load Param Mirror #1

Add One Mirror Enter New Values

Delete Selected Mirror

Mirror Range [m]

Mirror Az [deg.min]

Mirror El [deg.min]

OP-FTIR Bench Gain

Scanner Az Get Az and El

Scanner El

Set and Save Parameters

Align mode? Align gain Move Scanner

Gas Concentrations RPM Output VRPM Flux time series Reprocess AlarmSet

RPM On VRPM # of cycles/group CCF

Auto Update Run Again

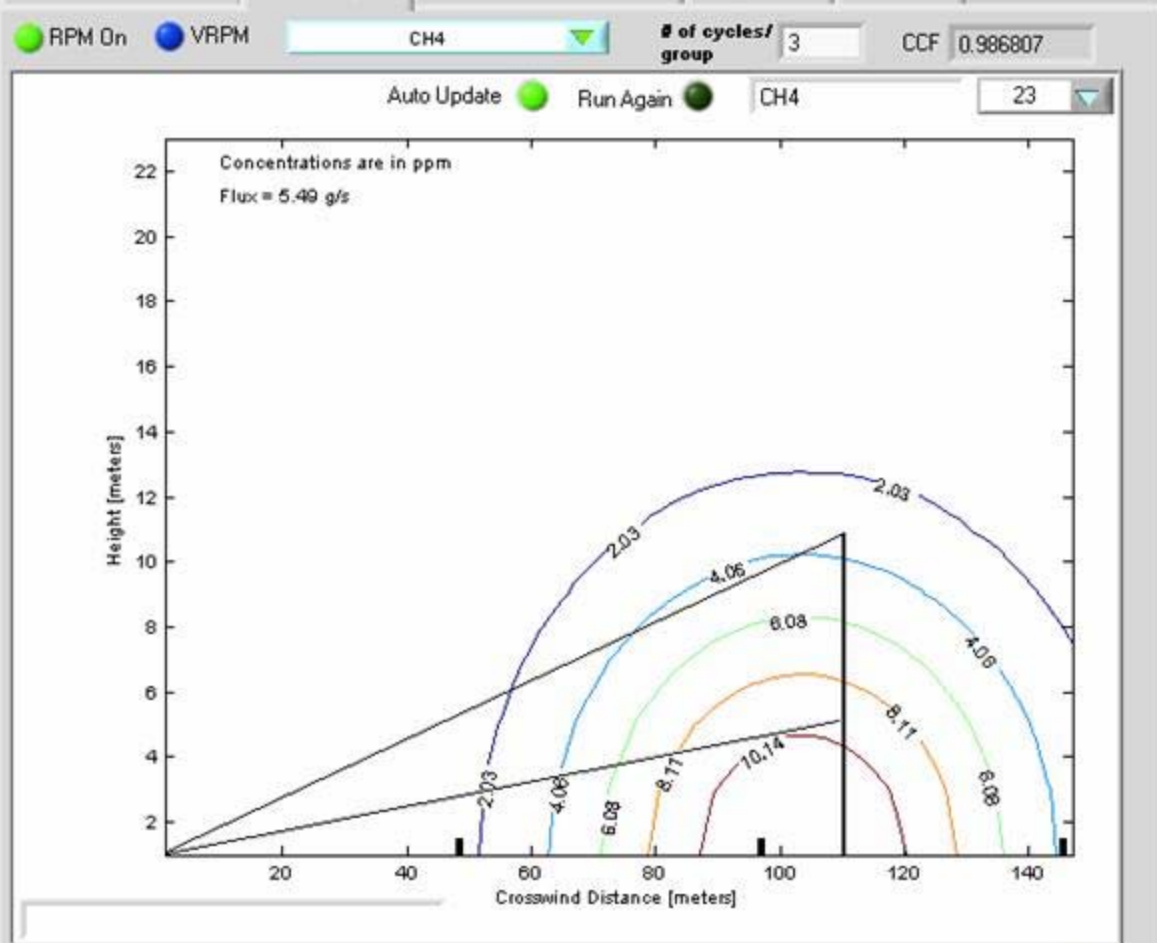

VRPM Parameters

Molecular Weight

Lower angle limit

Upper angle limit

Angle from N for Mirror on tower

of Vertical Wind Levels

Wind from Right of

Mean YD from normal

Flux Roundoff Factor

Contour Values Specified?

Contour Values

Current Cycle# Current Mirror#

Save Configuration

HRPM Parameters

Angle of x-axis from North (deg.min)

Length of x-axis (m)

Length of y-axis (m)

of pixels in x Setup

of pixels in y

Remove Beams?

Remove Pixels?

Scale Figure?

Background Subtraction? Value (PPM) Save all Figures as JPEG? Figure color in gray scale?

of Contour lines Contour Round off Factor

Wait time (milli-sec) for RPM auto update

Param Path

Interferogram Peak-to-Peak V

Collection % Complete

1D-RPM Concentration Profile on a Fenceline to Pinpoint the Fugitive Sources

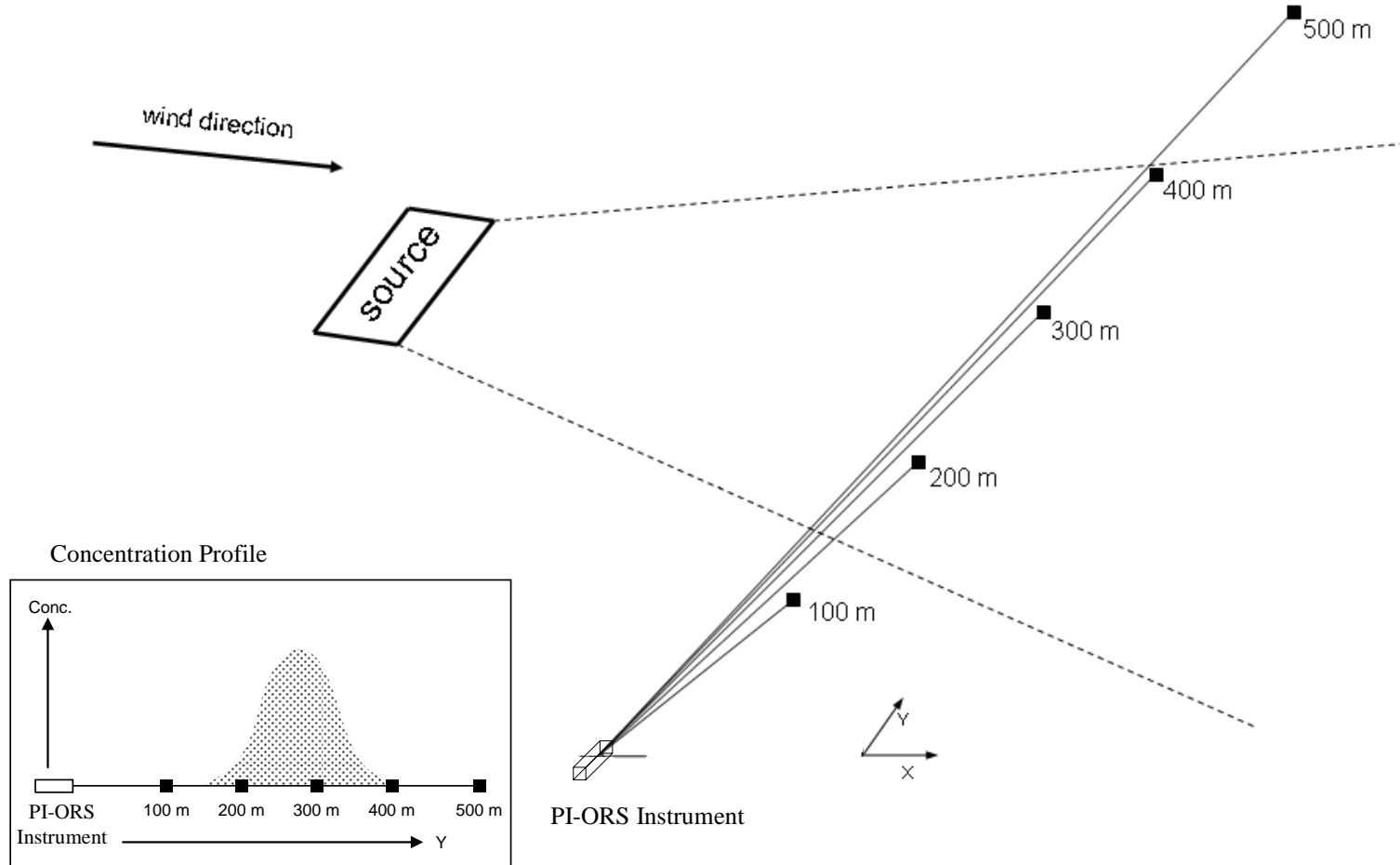

1D-RPM at Industrial Site

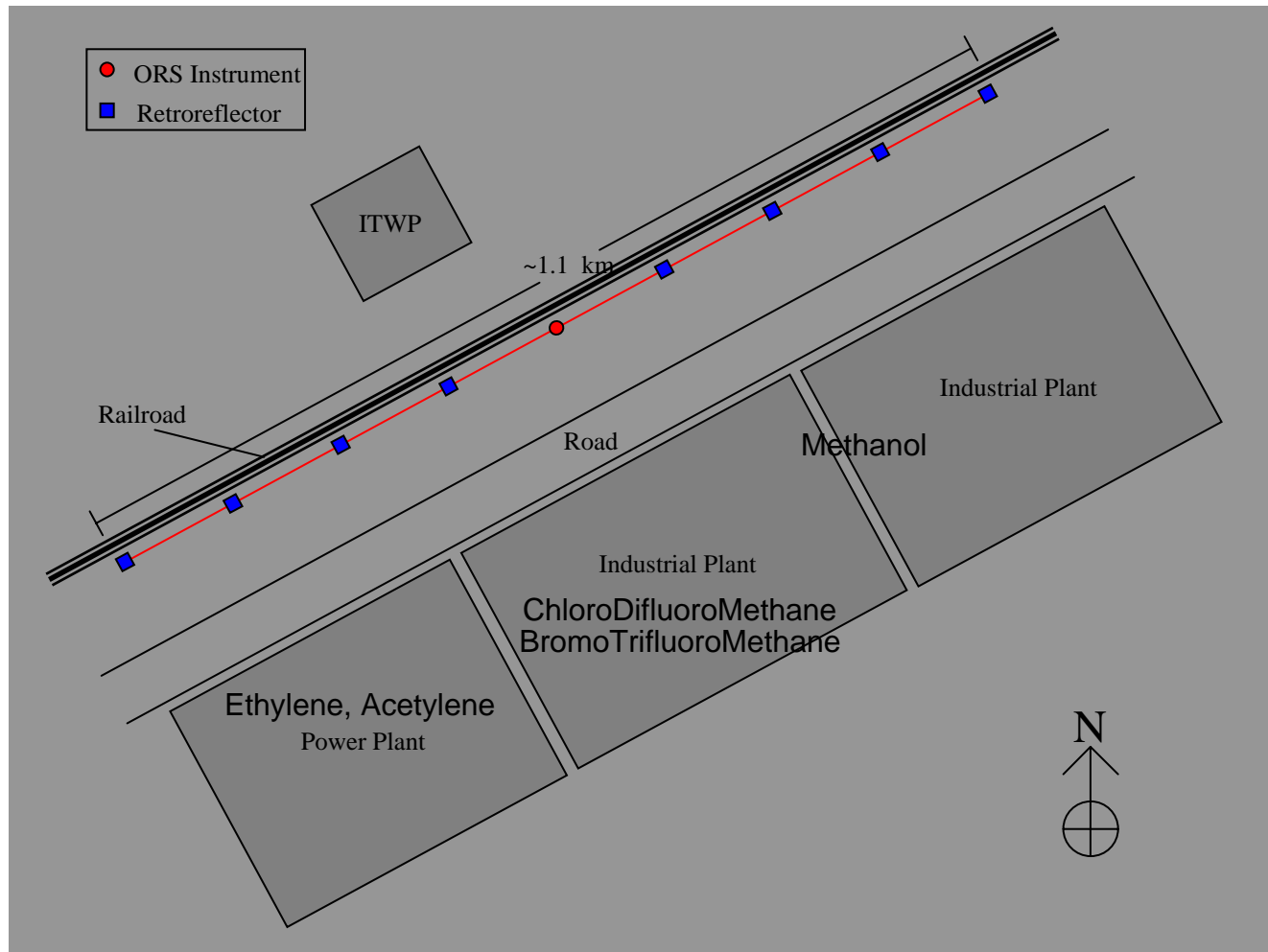

Summary

- Optical Remote Sensing can be used to detect fugitive emissions such as process leaks.
- Methodology selected depends on target compound(s) and source range.
- Combination of methodologies may provide most complete information.

Infrared Camera Use in the
Chemical Industry
David Williams, Office of
Research and Development, EPA

EPA Research & Development
National Exposure Research Laboratory

Infra-red camera use in the Chemical Industry

David Williams, Barry Feldmen, Andrew Pilant
Winthrop Wadsworth D&P Instruments
Carl Salvaggio, David Messinger RIT
see: SPIE Optics and Photonics 6299-26

Motivation

- Refineries and chemical plants emit hazardous air pollutants
- Industry is permitted a certain amount of emissions
- fugitive, or unknown leaks, can degrade regional air quality, cause non-attainment of air quality standards
- Efficient monitoring methods are required



Issues

- Leak Detection and Repair
- (LDAR) programs are costly
- and time consuming
 - large number of components at typical plant
 - monitor leaks using Organic Vapor Analyzer
 - must physically check the component
- leaks hard to find
 - less than 6% of emissions are



New Monitoring Technologies

- handheld specialized thermal cameras are used for leak detection
- can rapidly search for leaks
 - the number of screened in 1 day would take 3 weeks using standard method
- detection limits and sensitivity are currently being assessed





- Thermal Camera systems can be mounted on aerial platforms for rapid surveillance and monitoring

Vapor emissions from barge on Mississippi River



Thermal Camera Operations

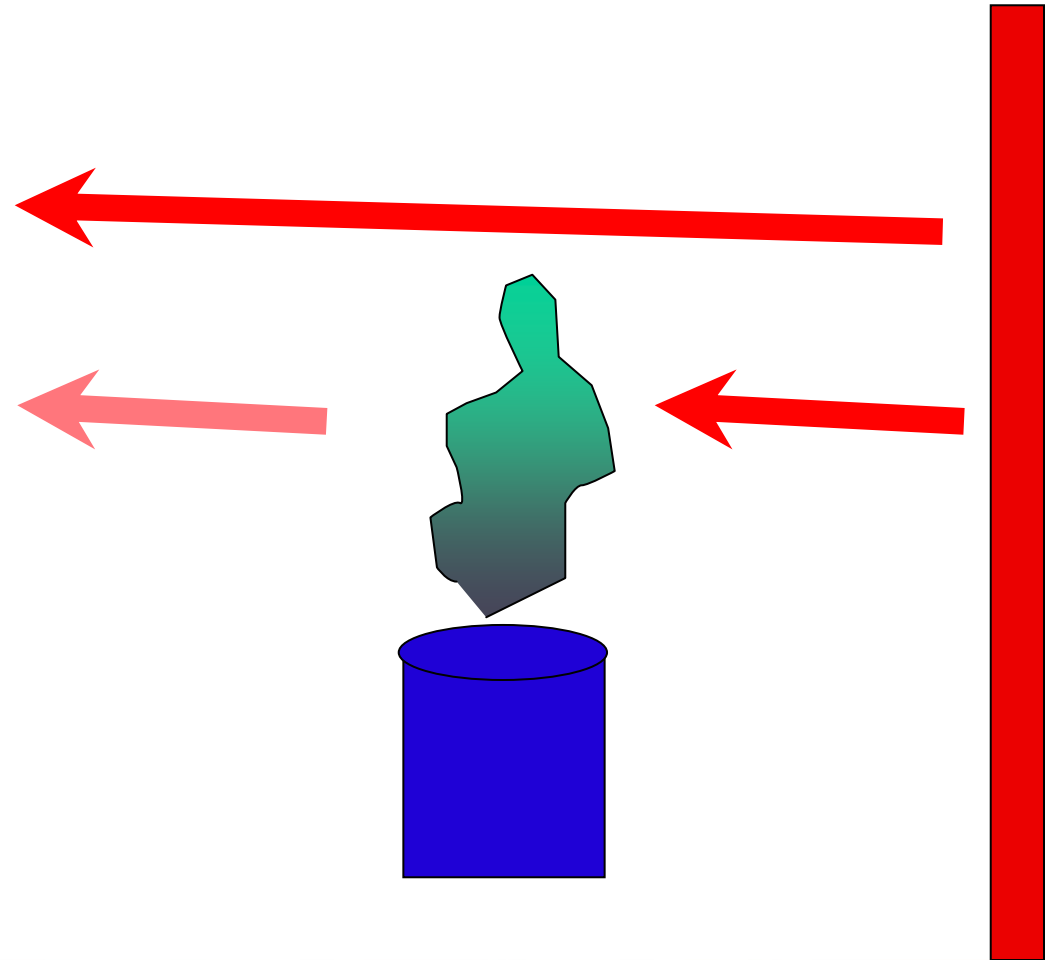
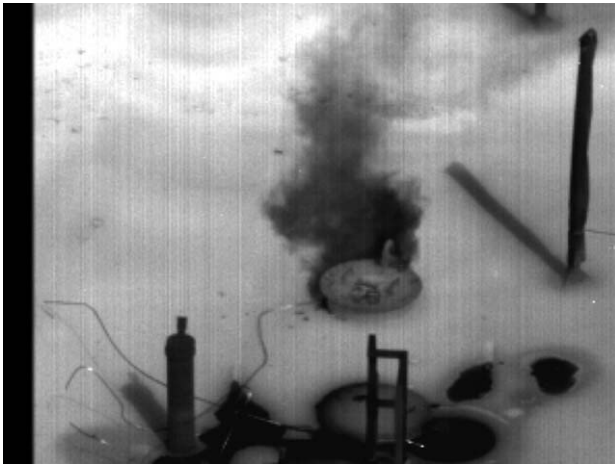

RESEARCH & DEVELOPMENT

Building a scientific foundation for sound environmental decisions

Strengths and Limitations

The FLIR GasfindIR is a broadband (monochromatic) mid-wave (3-5 μ m) infra-red video camera

•Strength:

- cooled device
 - high T sensitivity
- spectral filter
 - optimized
- video camera
 - creates movies of leaks

Limitation:

- no spectral information
- cannot quantify
- fixed spectral filter
- less sensitive to “off filter” gases
- Mid-wave IR only



Benefits of using IR cameras



- reduction of plant emissions
- reduction of leak detection and repair (LDAR) labor hours
- reduction of compound loss
 - Lyondell reported savings of \$75,000 during 1 month of use
- increase in safety
 - remember Texas City fire



Issues in use of cameras for LDAR

- cameras capture a leak for an instance in time
 - not a long term observation of leak
 - cannot be extrapolated to annual emissions
- no quantification of leak
 - concentration, mass flux
- camera only useful for mid-wave IR absorbers
- performance and detection limits are are not well known



Hybrid System

- Combines
 - the rapid component survey capability of the thermal camera
 - with the analytical capability of FTIR spectroscopy
- Determines leak flow or velocity from video
- FTIR: chemical identification and concentration
- combine data from both systems to quantify leak in mass per unit time



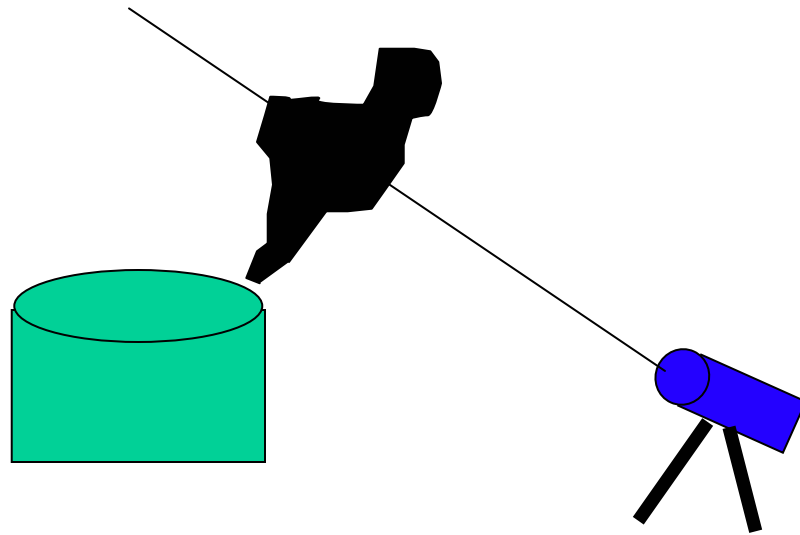

notional report:

Component: F567
Compound: Propane
Leak Flow: 40 g/hr

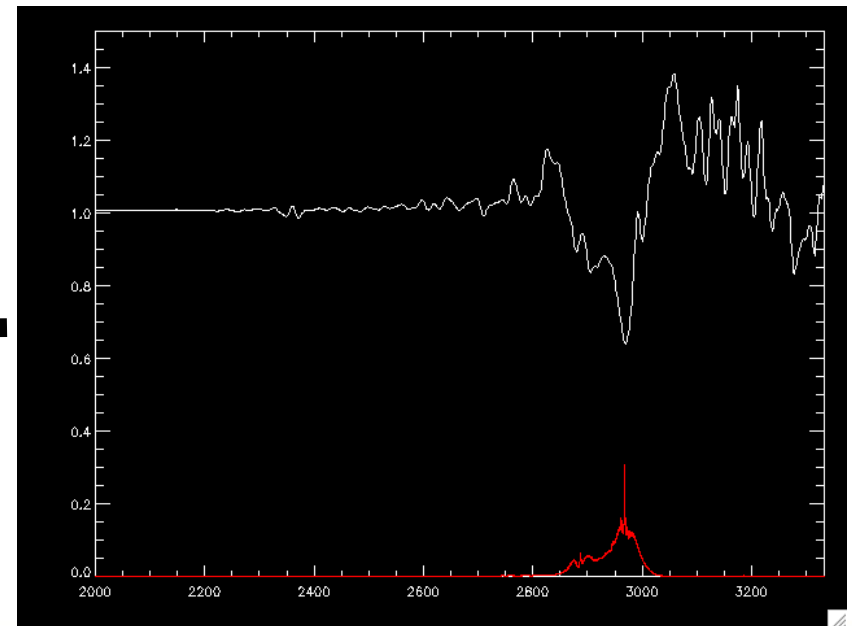

Ways to address issues

- long term observations for annual emission estimates
 - cameras currently cost \$ 75,000 plus \$ 10,000 for additional lenses
 - possibility of tower mount deployment
- No quantification
 - combine camera with spectrometer
 - combine with other sensors (OP-FTIR)
 - other technologies may be more suitable
 - low-power backscatter laser, scanning FTIR



Ways to address issues

- Mid-wave IR sensitivity
 - build full-spectrum capability
 - harder than you may believe
- Performance and detection limits
 - cameras leverage environmental conditions to obtain result
 - air T, background T, gas T, humidity
 - these usually beyond control
- Technology Verification is required



Technology Verification

- Many companies and agencies are using these cameras
 - monitoring, enforcement, safety
- A new alternative work practice for leak detection is being finalized
- How do we assess the performance of these technologies?
 - IR cameras are one of several technologies



Verification Project

- Funded under EPA's Environmental Technology Verification Program
- Project will test performance of several technologies for leak detection against a set of measures
- Stakeholder involvement is crucial



ETV Objectives

- Provide credible performance information for commercial-ready technology to help solve high risk environmental problems. **Aid:**

—

- ▶ **Purchasers** in making decisions to purchase innovative technologies
- ▶ **Policymakers and Regulators** in making policymaking and permitting decisions for innovative technologies, and
- ▶ **Vendors/Developers** in selling and further developing innovative technologies



Verification Definition

- To establish or prove the truth of the performance of a technology under specific, predetermined criteria or protocols and QA procedures.
- ETV does not:
 - Pass / fail,
 - Approve, or
 - Certify technologies

Acknowledgments

- EPA Regional Applied Research funding
- Rochester Institute of Technology
- D&P Instruments
- FLIR Corporation
- Leak Surveys Inc.
- Louisiana, Texas, Tennessee and Arkansas Depts of Environmental Quality



For more info contact:

- David Williams
- 919-541-2573
- williams.davidj@epa.gov

- also see:
- www.epa.gov/etv/este



Information Needs

- Detect Leak
 - thermal camera
- Identify Compound
 - need GC/MS or FTIR spectrometer
- Determine Concentration
 - estimated using organic vapor analyzer, or GC/MS
- **Quantify the Leak**
 - estimate the mass flux or grams/hour of emission
 - Need all of the above to accomplish



Systems

- FLIR GasfindIR
- D&P TurboFT
- Sidehand computer does all processing in real time
- also see SPIE papers 6302-01, 6302-02



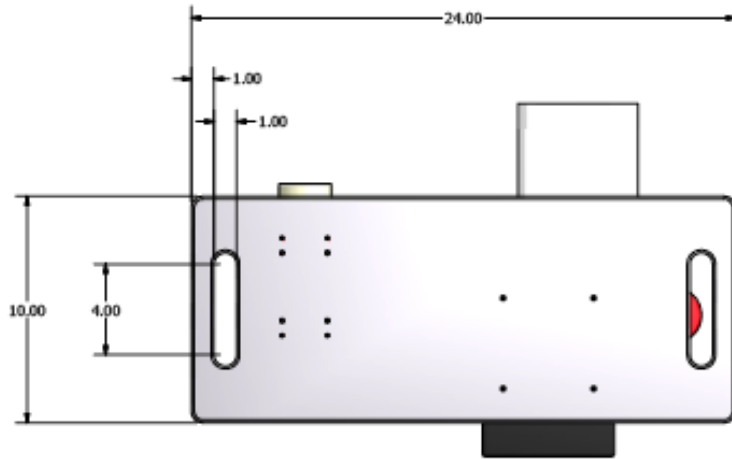
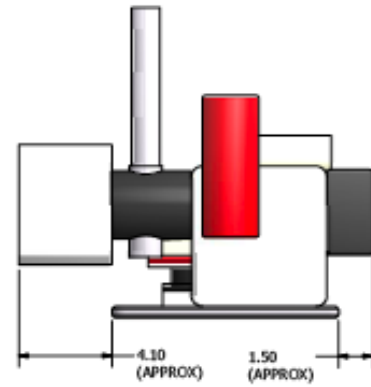
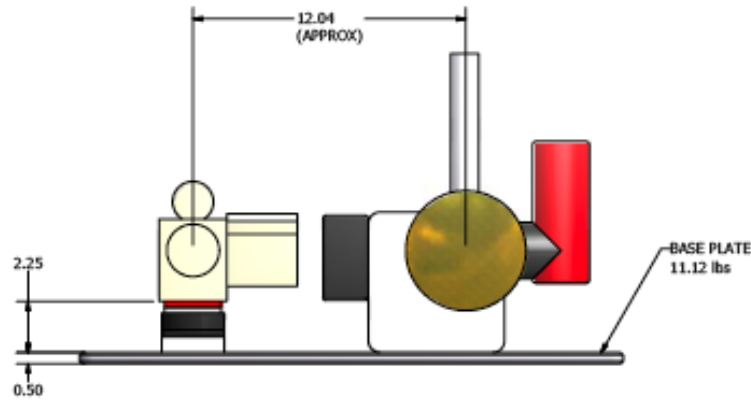
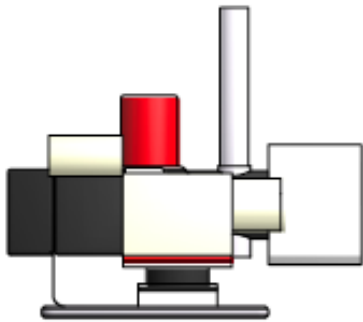
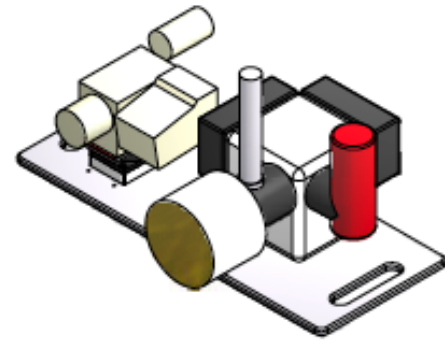
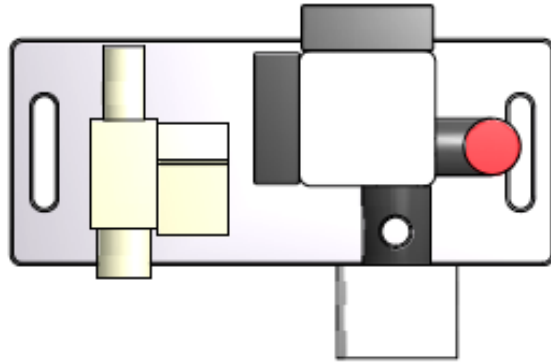
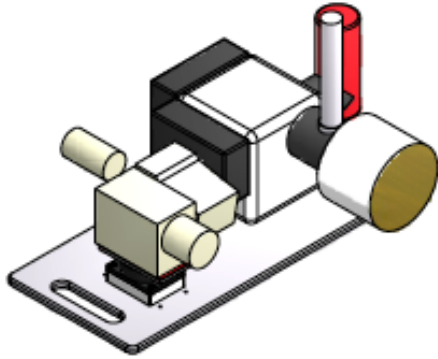

DRAWN	Co-op	7/26/2006		
CHECKED			TITLE	
QA				
RIG				
APPROVED				
	SIZE	DWG NO	REV	
	C			
	SCALE	SHEET 1 OF 1		



RESEARCH & DEVELOPMENT

Building a scientific foundation for sound environmental decisions

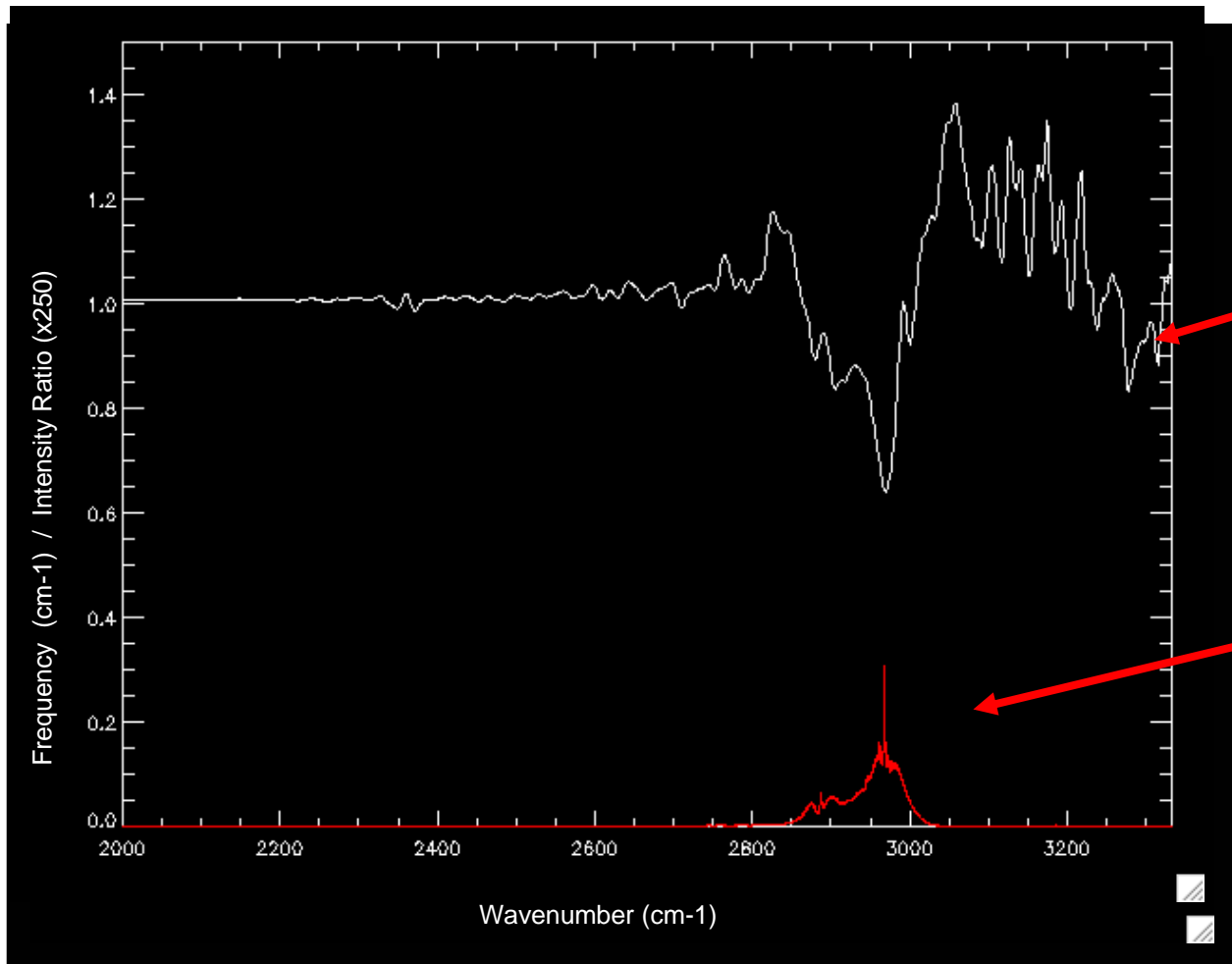

C_3H_8 (propane) at 29.4°C
(radiance ratio with
background)

C_3H_8 (propane) at
25°C
(absorbance scaled
by 250x)

An 8" CI blackbody at 80°C was positioned as a background for a propane source releasing at air temperature (29.4°C). The blackbody interferogram/spectrum was recorded (at a distance of 30 feet) with the D&P Model 202 prior to and during the propane gas being released. The ratio of the spectra (with gas divided by without gas) was computed and plotted above.

Next Steps

- Field tests of system in fall
- Verification of optical and thermal imagers for leak detection
 - supports alternative work practice for LDAR
- EPA's alternative work practice for LDAR will create a multimillion dollar market for development and use of these devices optical and thermal devices



DIAL Emissions Monitoring in the
United Kingdom
Rod Robinson, National Physical
Laboratory, UK



National Physical Laboratory

The Application of DIAL for industrial emissions monitoring

Rod Robinson

Environmental Measurements Group
National Physical Laboratory
UK

rod.robinson@npl.co.uk

Outline of Presentation

- Introduction
- Development and History of DIAL
- Capabilities of DIAL
- Measurement Applications

Environmental Measurements Group National Physical Laboratory



- UK's primary reference laboratory (cf. NIST)
- Part of Analytical Science Team at NPL.
- Comprehensive range of environmental services
 - Research and instrument development
 - Measurement services
 - Calibration and validation
 - Consultancy, protocol development etc
- Client sectors
 - industry
 - regulators (UK & European)
 - central and local Government
- Underpinning research into measurements and standards, supported by DTI's Valid Analytical Measurements (VAM) Programme.



NPL's activities in this area

- Primary Gas Standards and Traceable Reference Mixtures
 - to provide industry with internationally-accepted traceable standards upon which measurements of pollutant emissions, occupational exposure, and air quality can be based.
- Atmospheric Gas Monitoring Techniques
 - to develop techniques for rapid, cost-effective measurements of atmospheric trace gases
 - to develop calibration and validation programmes for monitoring methods
- Provide measurement services based on these techniques

Brief Review of Optical Remote Sensing

- Conventional techniques measure gases at a single point in the atmosphere
- Remote sensing uses a beam of ultraviolet, visible or infrared radiation to measure gas concentration along a line-of-sight path
 - Active or passive
 - Single or double ended
 - Range resolving or path-integral
- The beam can be scanned to enable measurement over a large area or throughout a volume of gas

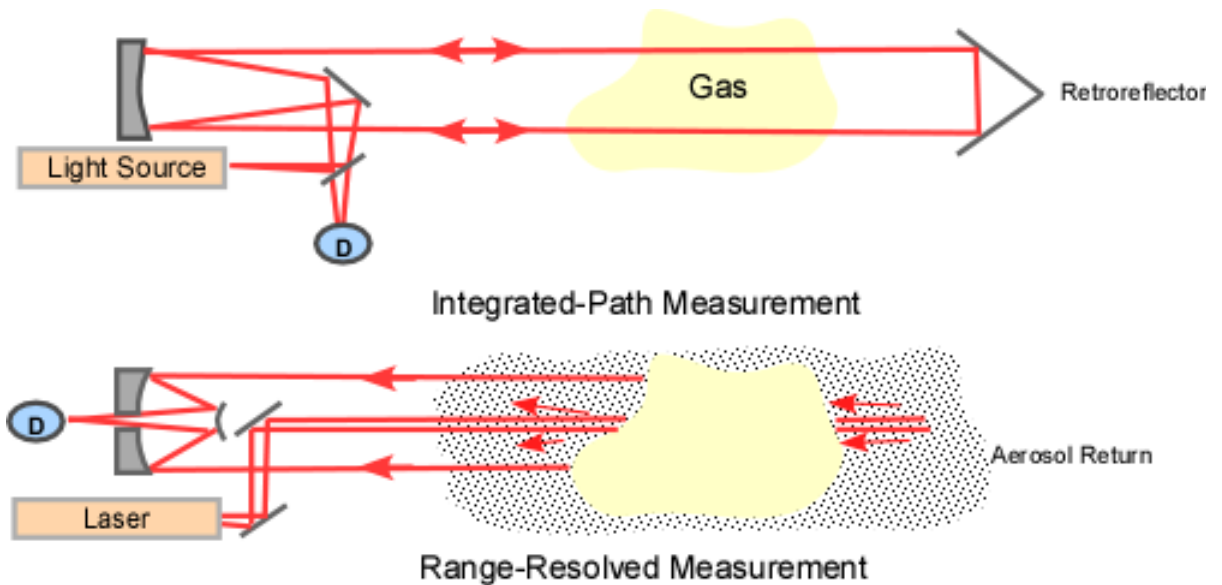

NPL Differential Absorption LIDAR

- Able to measure wide range of species
 - VOCs including methane, ethene, methanol, and general hydrocarbons
 - SO_2 , NO_2 , NO , Hg , HCl
 - Benzene, Toluene, Xylenes
- Fast , ~10 minutes for a high resolution flux measurement
- Spatial resolution <8 metres
- Range up to 3 km
- Measurement sensitivity typically 50 ppb



Principle of Lidar

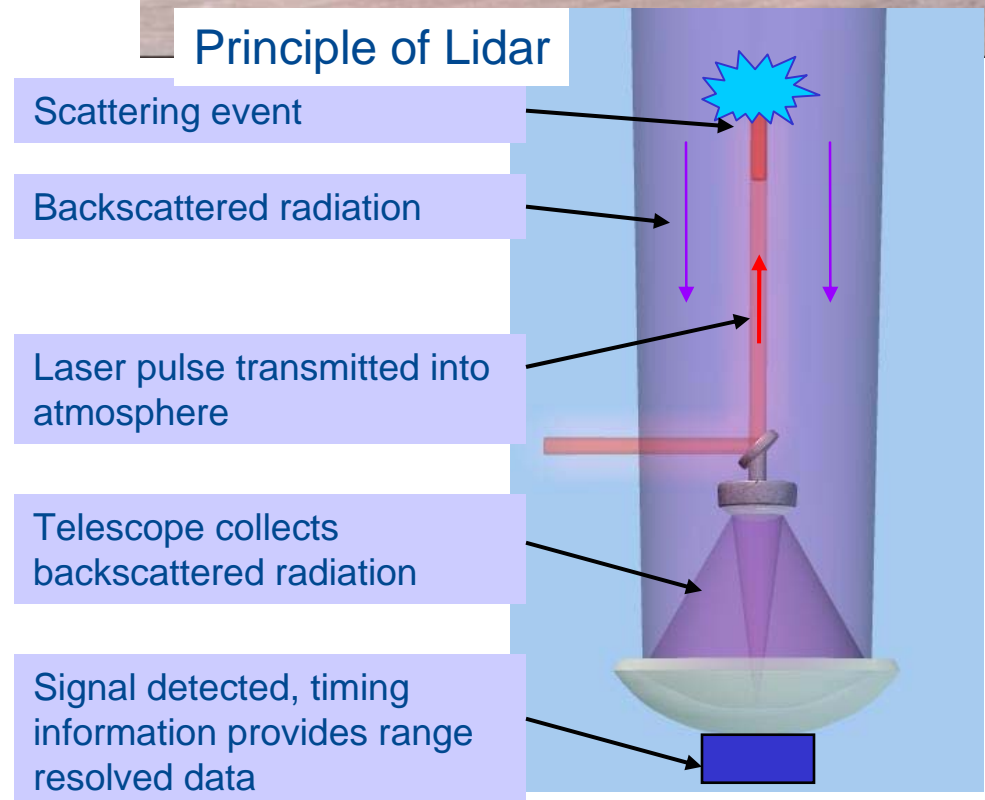

Development of DIAL

- Extension of lidar to Differential Absorption – allows measurement of concentrations of gases
- NPL developed the source and detection systems to enable IR DIAL in mid/late 1980's
- Commercial system built for BP late 1980's
 - Now spun out from BP as Spectrasyne
- Commercial system built for British Gas/Shell/Siemens 1995
- This system now operated by NPL, currently being refurbished with new lasers and detection system
- Developed DIAL as a routine measurement service
- Airborne DIAL system currently being built for UK atmospheric research aircraft



NPL DIAL Performance

Infrared DIAL System			UV/Visible DIAL System		
Species	Sensitivity	Max. Range	Species	Sensitivity	Max. Range
CH ₄	50 ppb	1 km	NO	5 ppb	500 m
C ₂ H ₂	40 ppb	800 m	NO ₂	10 ppb	500 m
C ₂ H ₄	10 ppb	800 m	SO ₂	10 ppb	3 km
C ₂ H ₆	20 ppb	800 m	O ₃	5 ppb	2 km
higher alkanes	40 ppb	800 m	Hg	0.5 ppb	3 km
HCl	20 ppb	1 km	Benzene	10 ppb	800 m
N ₂ O	100 ppb	800 m	Toluene	10 ppb	800 m
CH ₃ OH	200 ppb	500 m	Xylene	20 ppb	500 m

NB. The sensitivities apply at a range of 200 m for a 50 metre plume

Atmospheric absorption

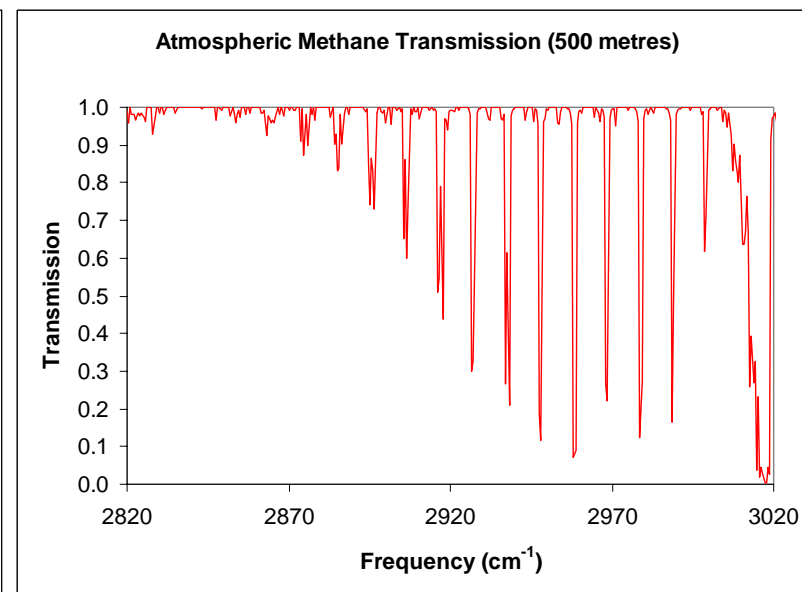
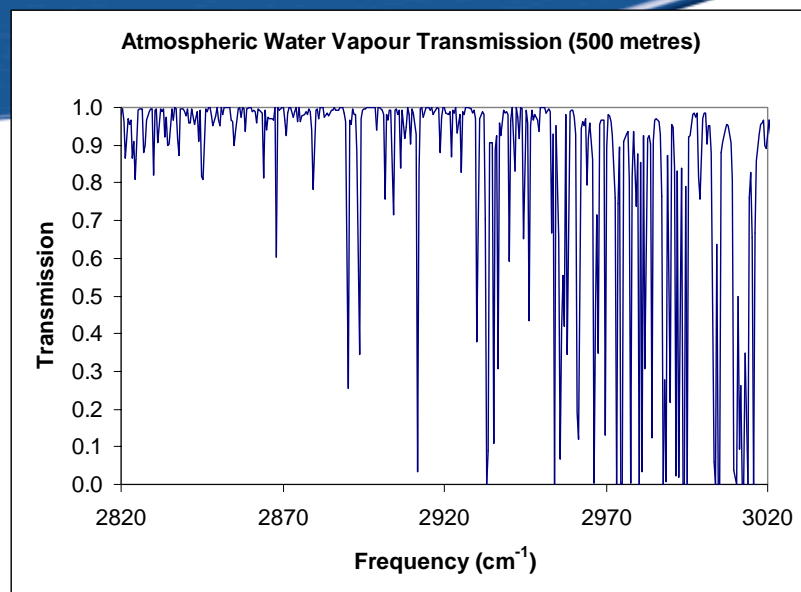

Absorption Spectrum of Unleaded Petrol

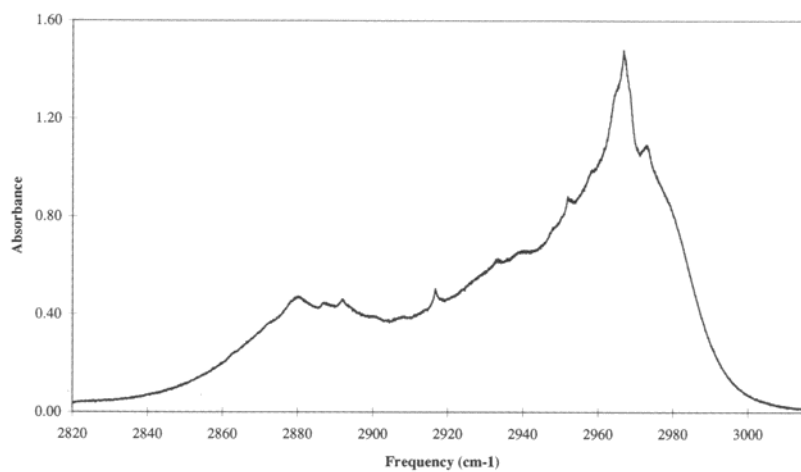

Examples of field validation measurements

- Repeated DIAL measurements downwind of a source of a known **flux** of methane agreed to within +/- 10% of emitted value (10 kg/hour)
- Comparison with a line of pumped absorption tube samplers inside chemical plant agreed with DIAL measurements of :
 - aliphatic hydrocarbons to within +/- 12%
 - toluene to within +/- 15%.
- VOC emission measurements from a petro-chemical storage facility made by DIAL and standard point sampling methods agreed to within +/- 8%.

Windowless Cell for 'Free-space' Calibration



- 10 m long x 1 m diameter
- External calibration of open-path instruments
- No reflections from windows

- On-line monitoring of internal conditions
- Dynamic operation
- Also provides range-resolution data for lidar-type instruments

Industrial Applications of the NPL DIAL Facility

- Direct quantification of emission from multiple sources inside complex plant – measurement of flux
- Plant surveys to identify and quantify fugitive emission sources – identification of leaks
- Flare and burner efficiency measurements
- Compliance monitoring and boundary fence surveys – total site emissions and concentration levels
- Government-supported surveys to determine actual emission levels and impact of industrial plant locally and nationally.



DIAL measurement configuration for flux measurement

- Vertical scans enable plume mapping and flux calculation

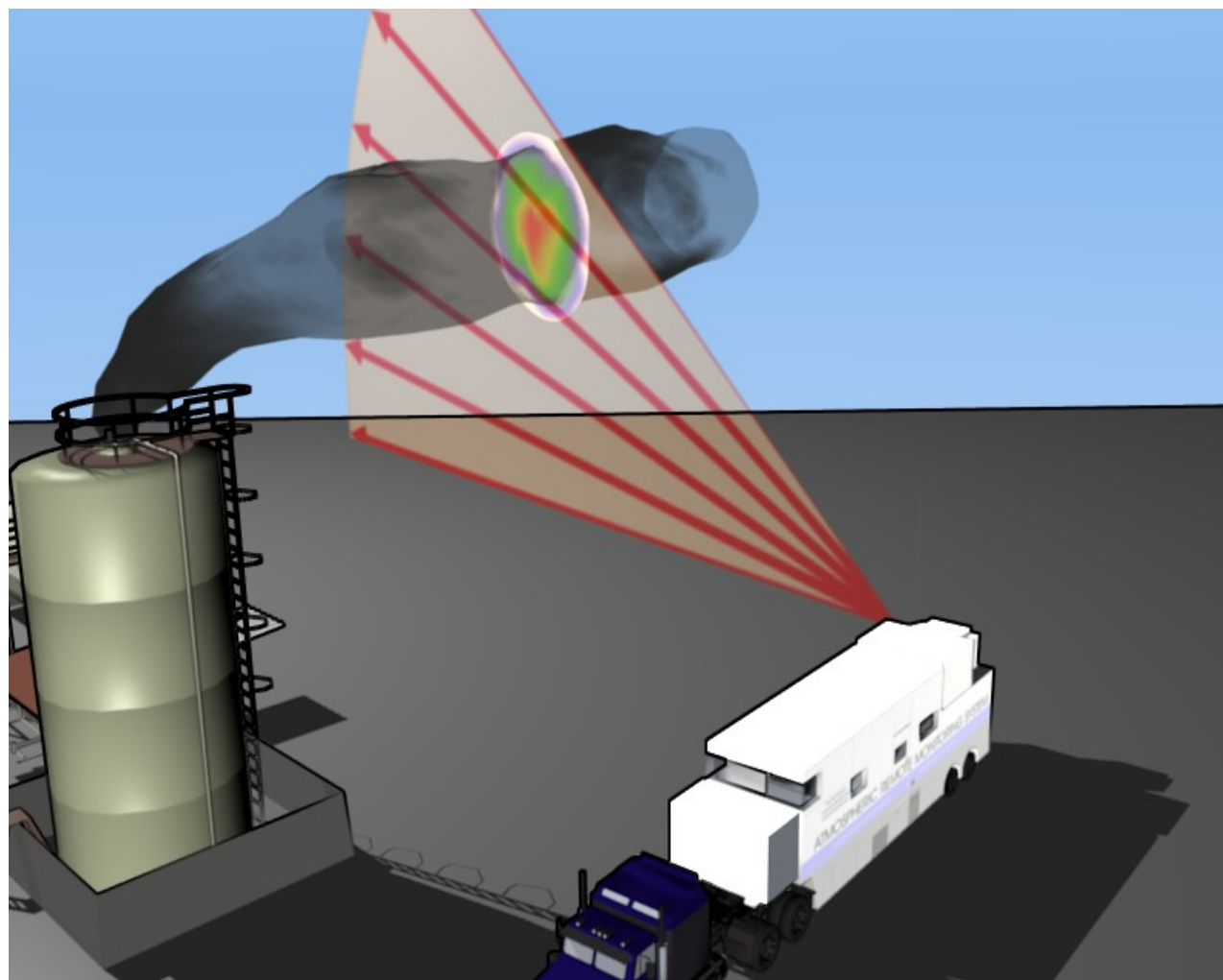

DIAL Can Identify and Quantify Emissions from an Industrial Plant

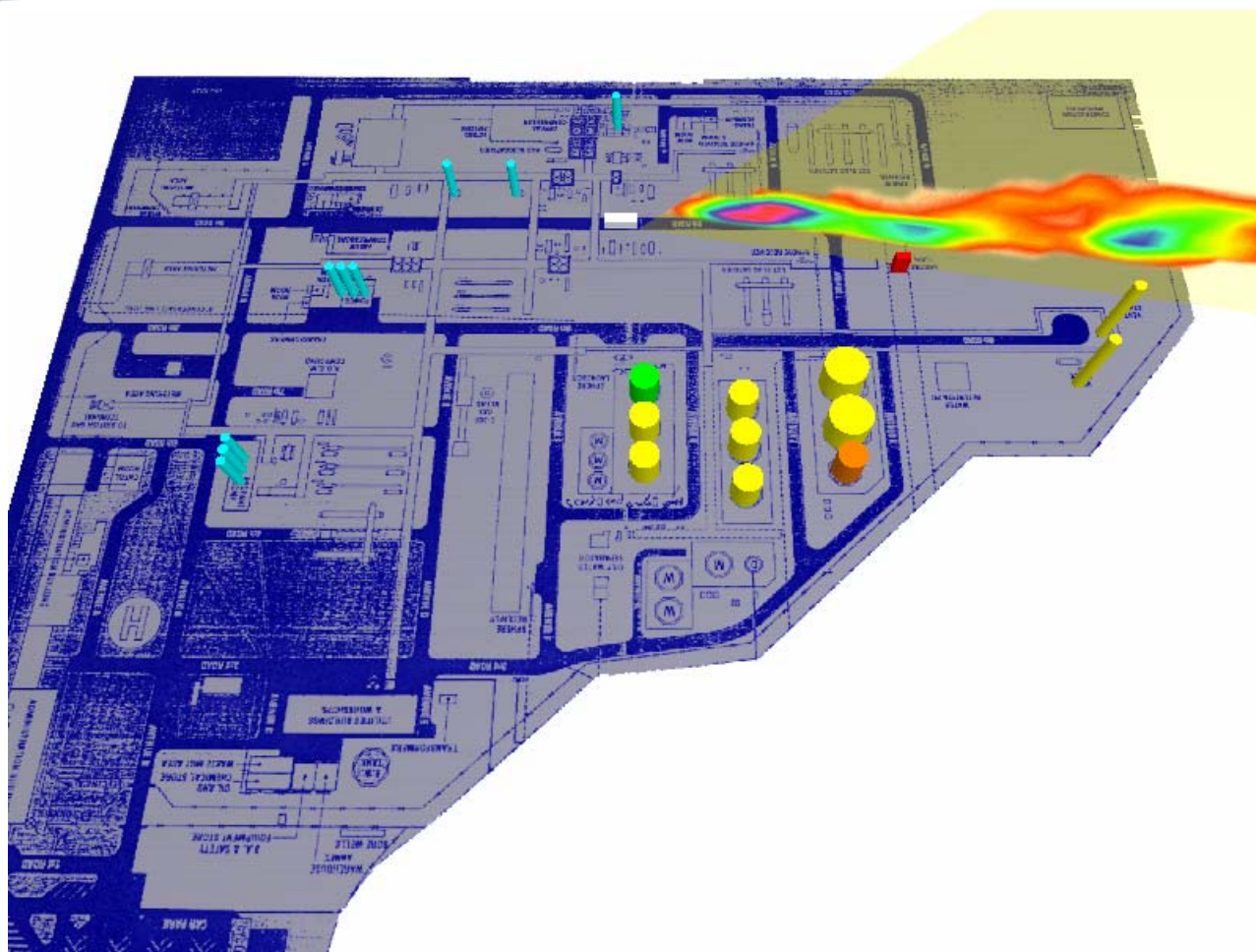

DIAL Can Identify and Quantify Emissions from an Industrial Plant

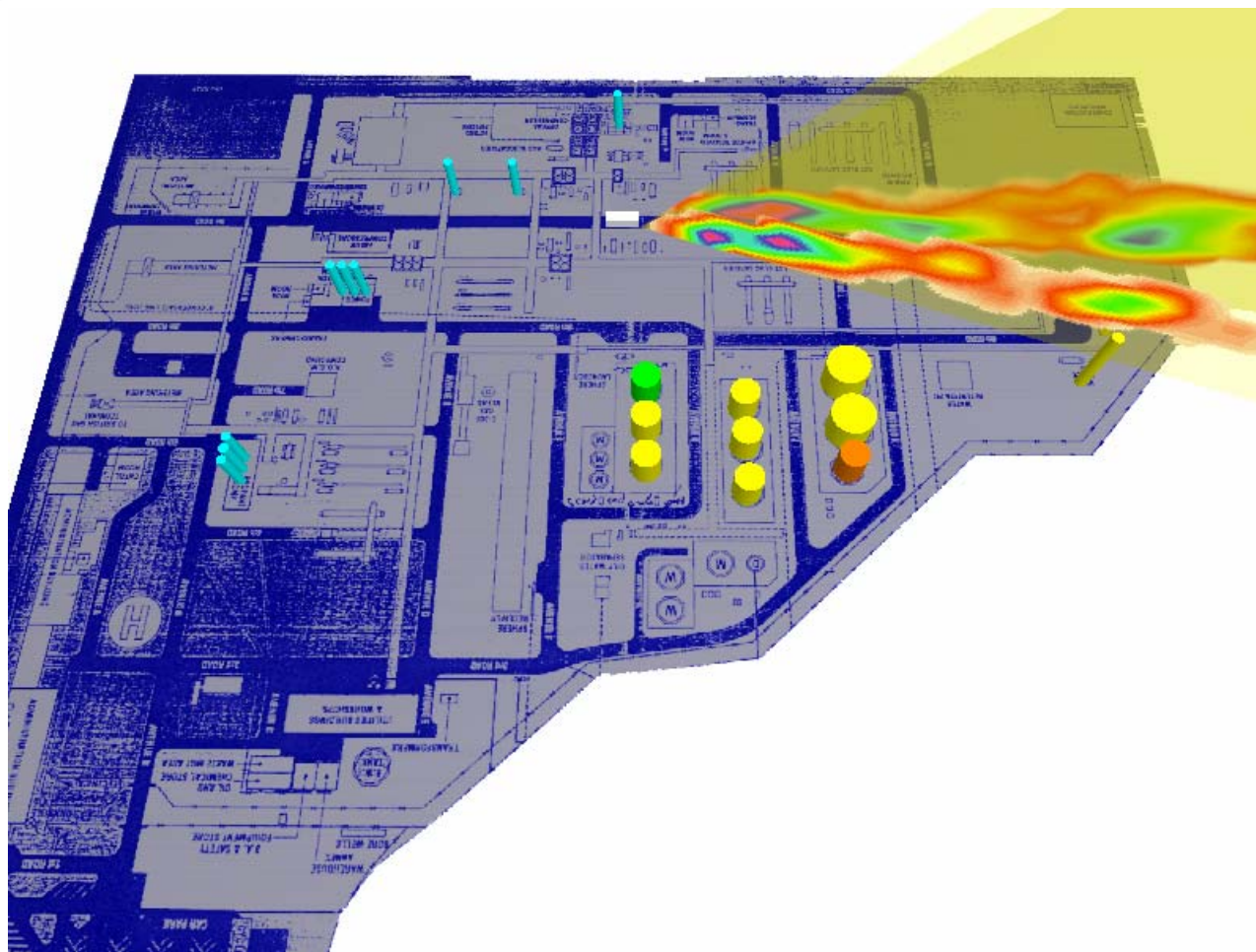

Measuring Pollution from Flares

- Have carried out flare efficiency measurements at a number of sites
- Typical values for efficiency ~99%
- Have seen poorly performing flares with ~9% emission factor



Measurement Of Fugitive VOCs Emissions From an Oil Refinery

- NPL DIAL used to locate and quantify the main fugitive VOC emission sources in a plant refining crude oil into products including gasoline, kerosene and fuel oil.
- The DIAL measurements showed that the overall gaseous emission from the refinery amounted to product losses of >\$1M per annum.
- The measurements also identified unpredicted leaks at high elevations in the process plant, and a suitable remedial programme was implemented
- The second set of measurements showed that a 50% reduction in losses from the process unit had been achieved.

Measurement Of Voc Emissions From Storage Tanks At An Oil Refinery

- Measured the total emissions to atmosphere of VOCs from storage tanks at a major refinery and petrochemical complex in the UK.
- Emission fluxes measured with the DIAL compared with those derived from CONCAWE / API estimation procedures.
 - NB this used API 2518(91) API 2517 (89) and API 2519 (83)
- Significant fugitives from gasoline blender – not accounted for in estimated emissions
- Average factor between DIAL and API estimation was 2.7,
- Range of factors from 0.8 to 4.0

Improving Emissions Inventories

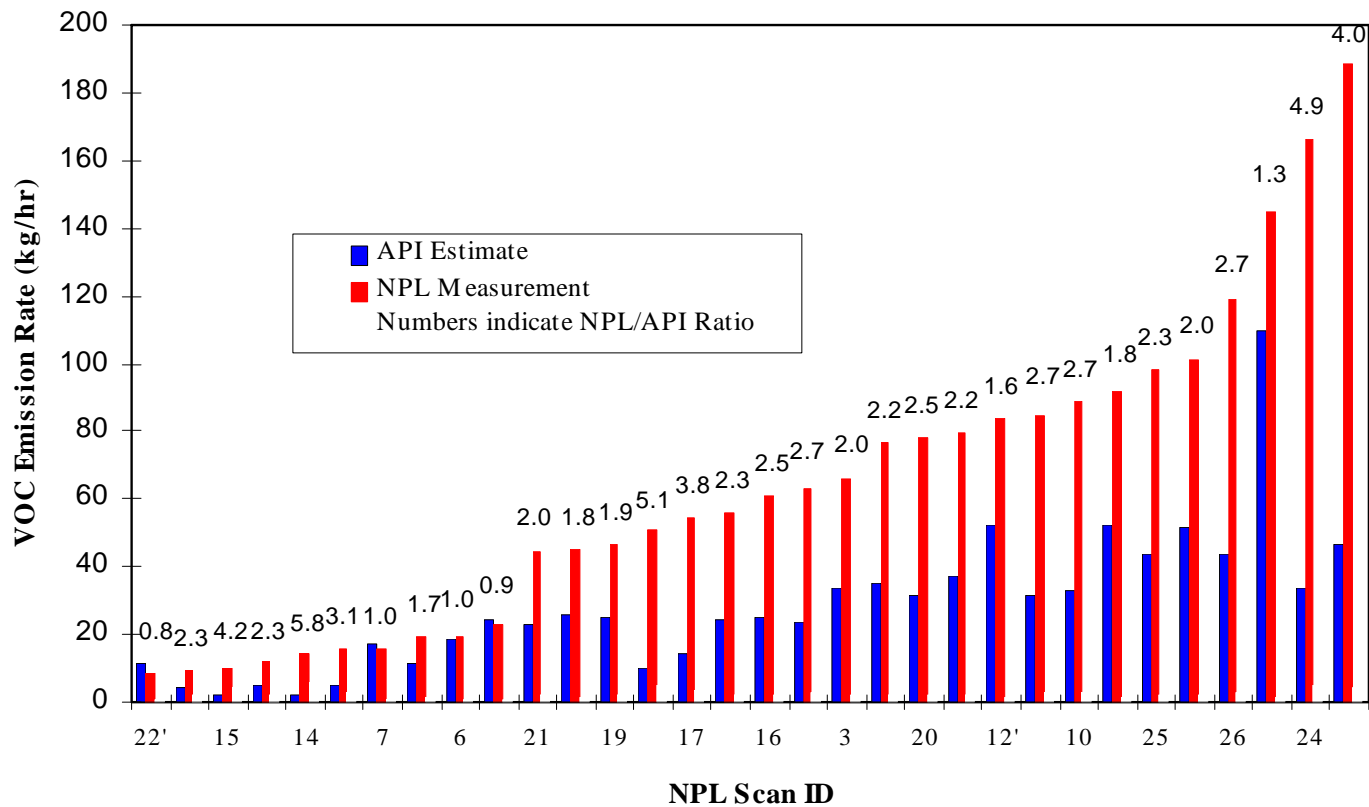

Ethylene Emissions From A Chemical Works

- Measurements at a petrochemical plant, to investigate emissions from polyethylene plant – one old one newly commissioned.
- The measured emissions were in the range 47 to 59 kg/hour, equivalent to 381-477 tonnes per annum.
- The emissions from the new polyethylene plant were equivalent to 0.18% of throughput, compared to 0.27% for the older plant.
- The estimated emissions from the new process unit were 28% lower than the measured value.

Measuring Driver Exposure when Filling Petrol



Concentrations Near Pump

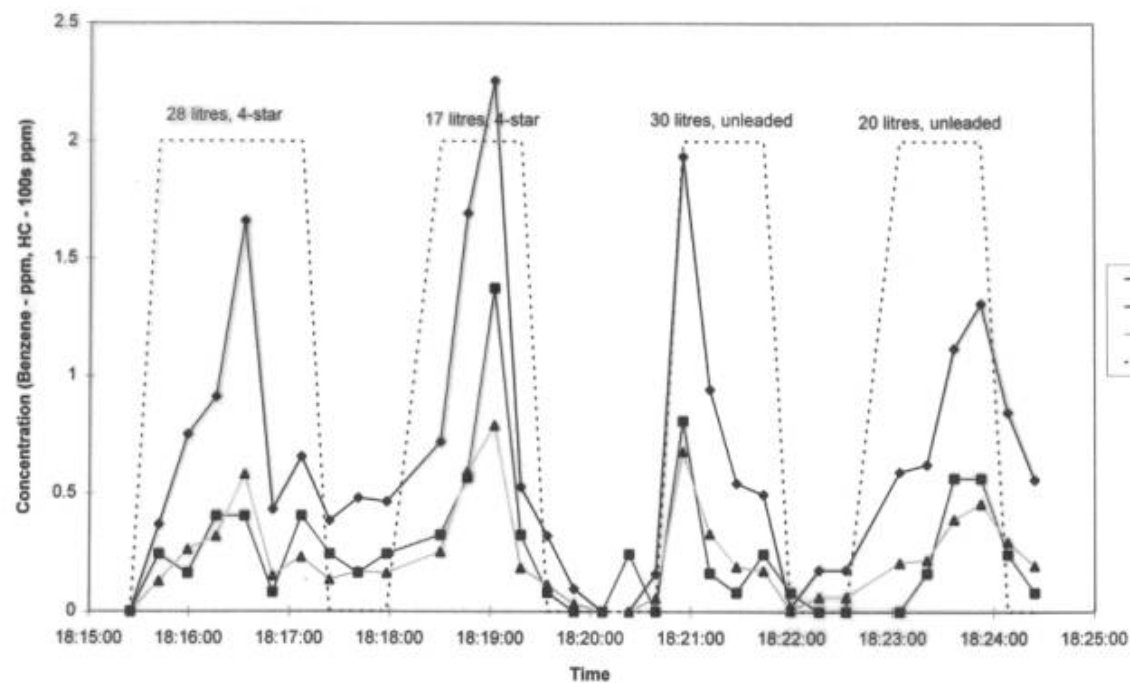

- Loss 0.3 – 0.15 %
- Vapour recovery reduced this by 63%

DIAL Measurements of Percentage VOC Mass Loss During Vehicle Filling

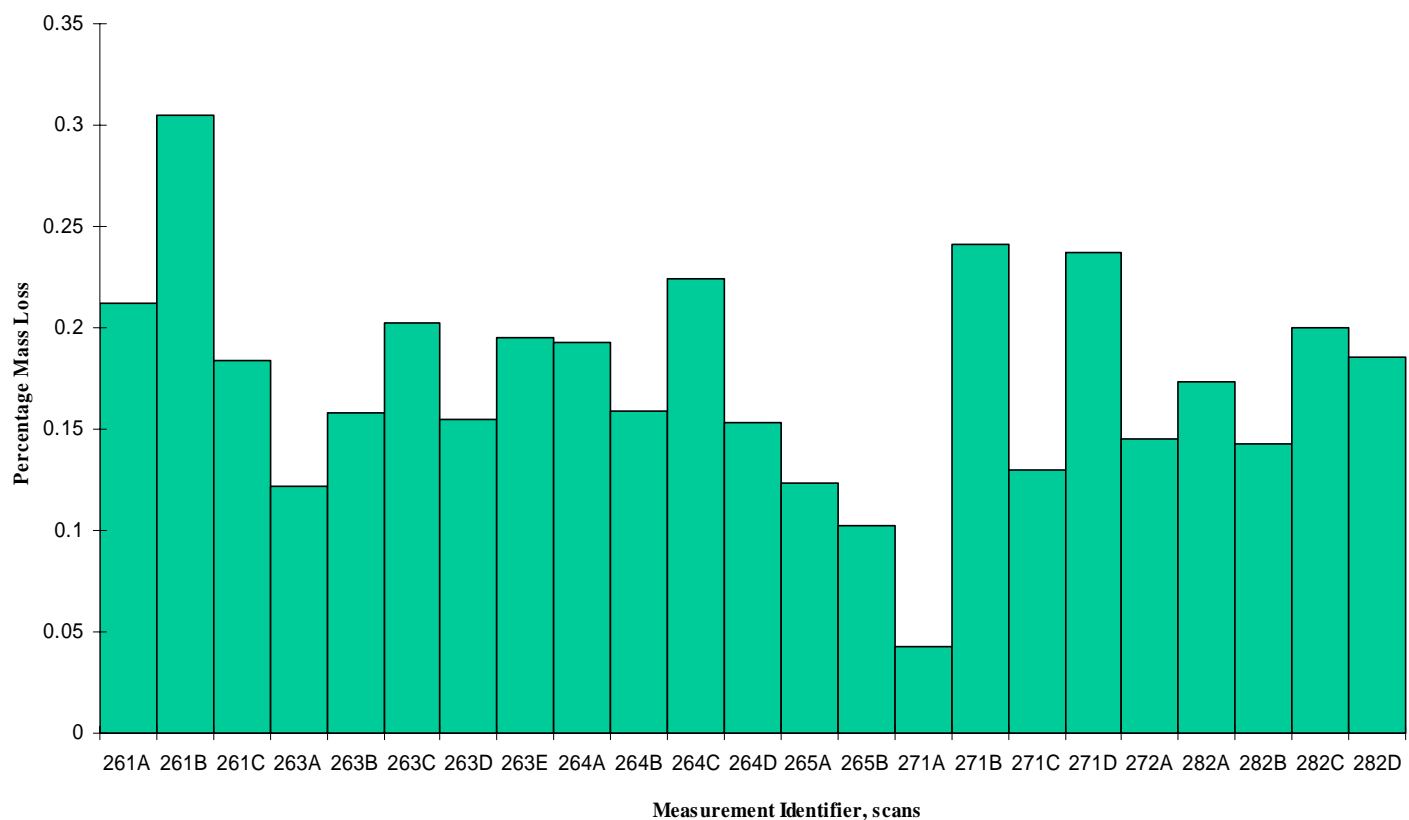

Environmental impact of emissions from industrial sources

- Source attribution for ground-level pollution events by tracking pollutant concentrations back to the source(s).
- To monitor airborne plume behaviour, and provide data for dispersion models.
- To identify and quantify local emission sources of sulphur dioxide.
- To direct a mobile point-monitoring laboratory to the location of plume grounding events.

DIAL Measurements at Cement Works



Sulphur Dioxide Plumes Measured 2.1 km Downwind of Source

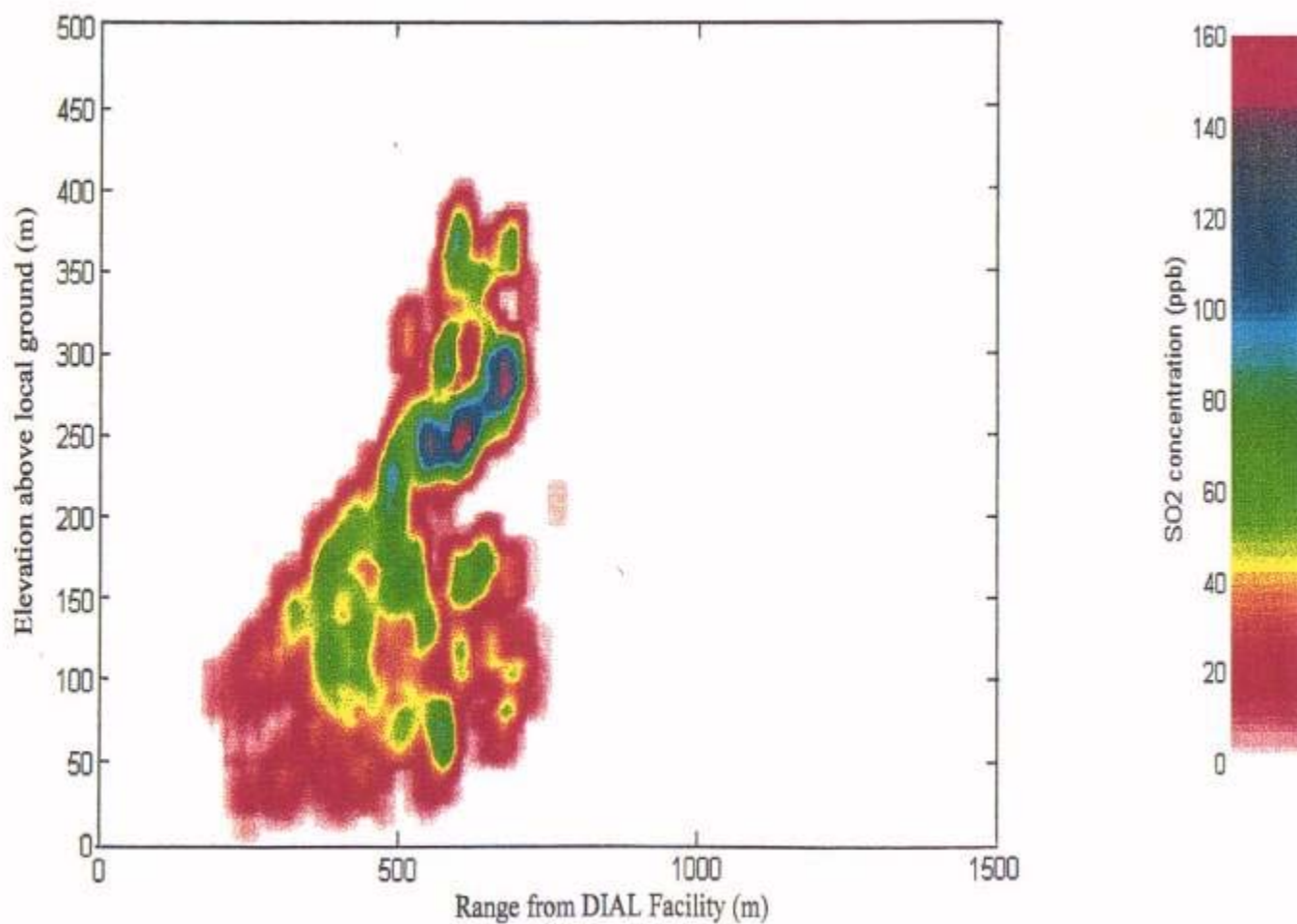

Sulphur Dioxide Plumes Measured 2.3 km Downwind of Source

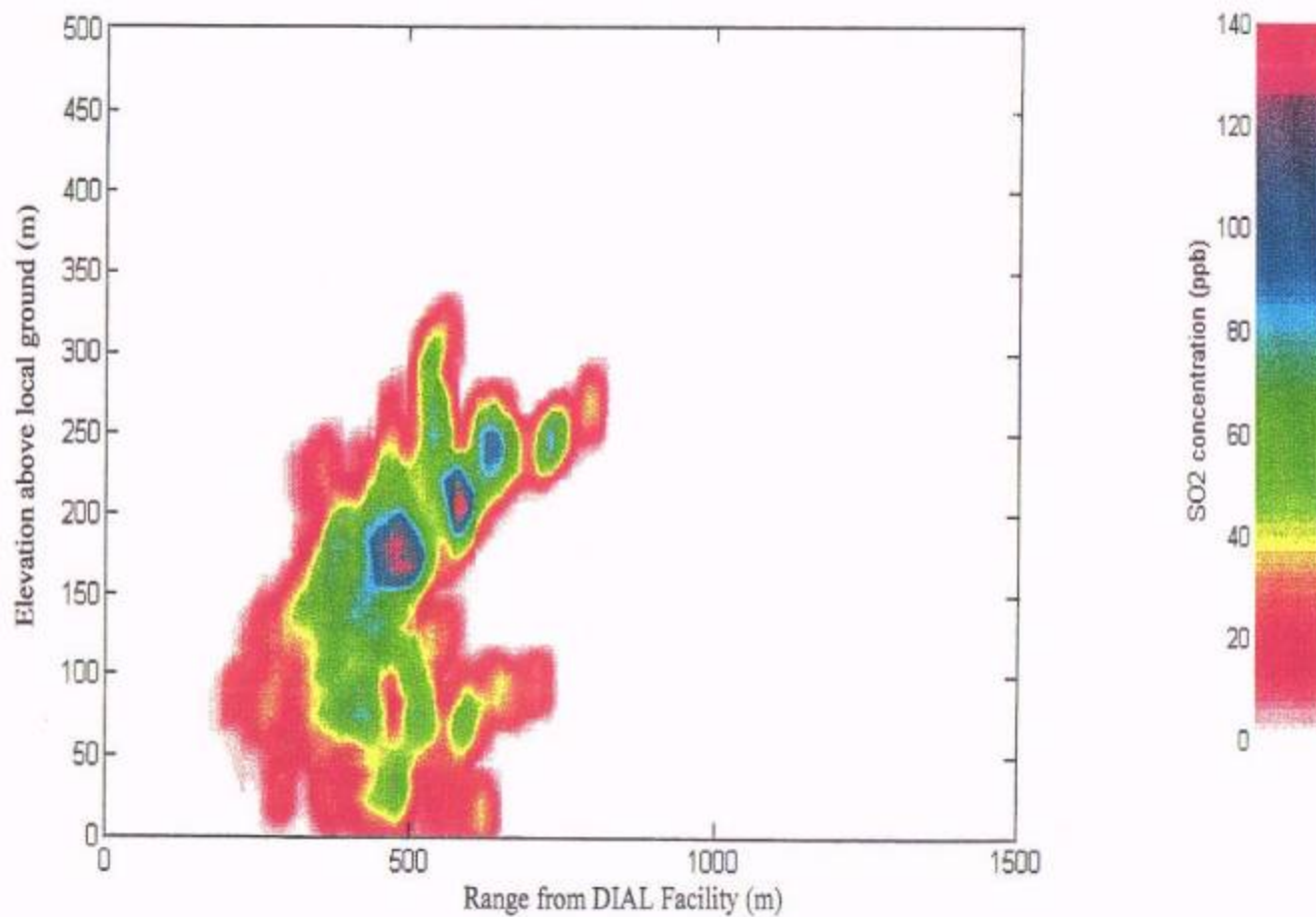

Vertical Trajectory of Sulphur Dioxide Plumes Emitted from Industrial Stacks

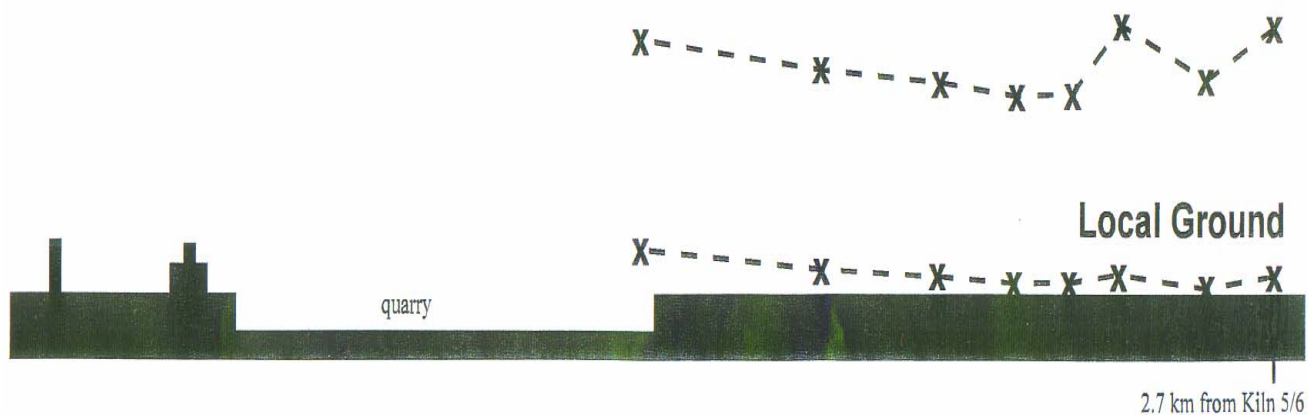

Temporal Variation in Sulphur Dioxide Concentration Close to Ground Level

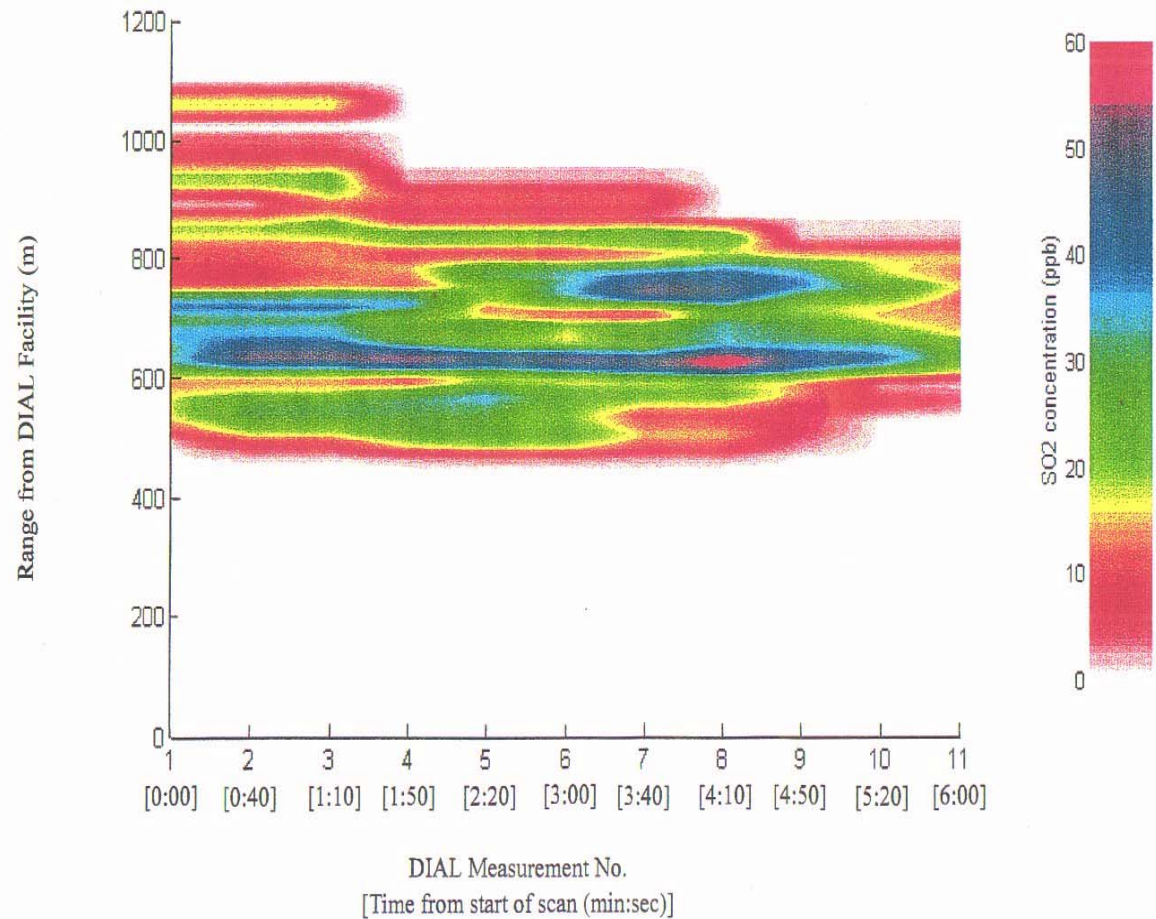
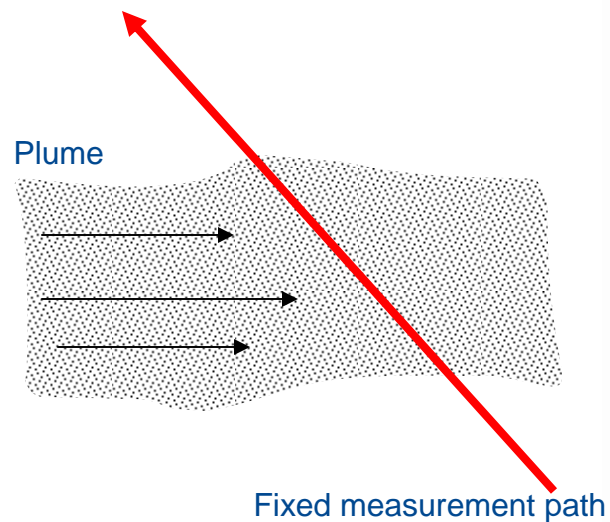

Plume tracking

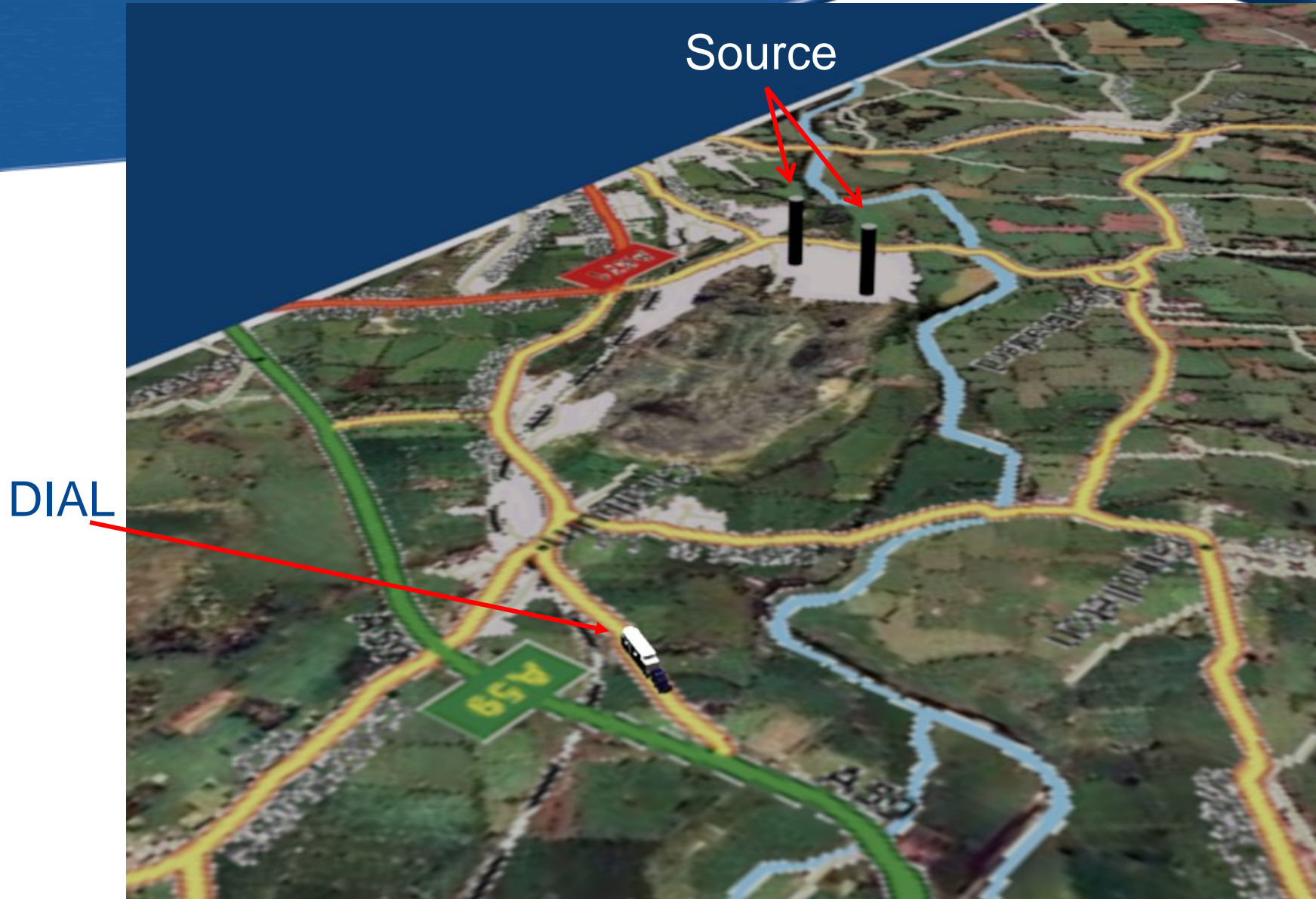

Plume tracking

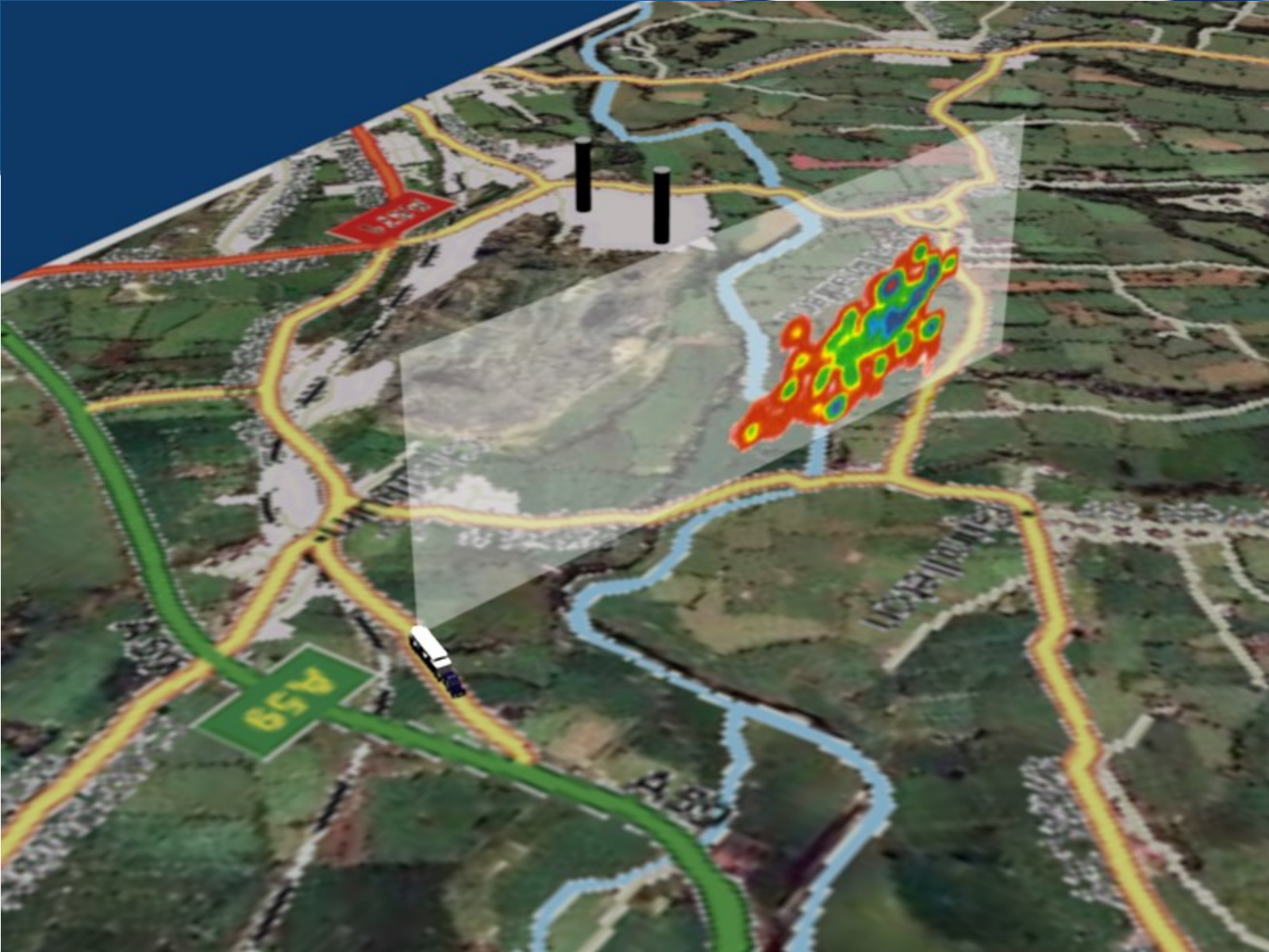

Plume tracking



Plume tracking



Plume Tracking

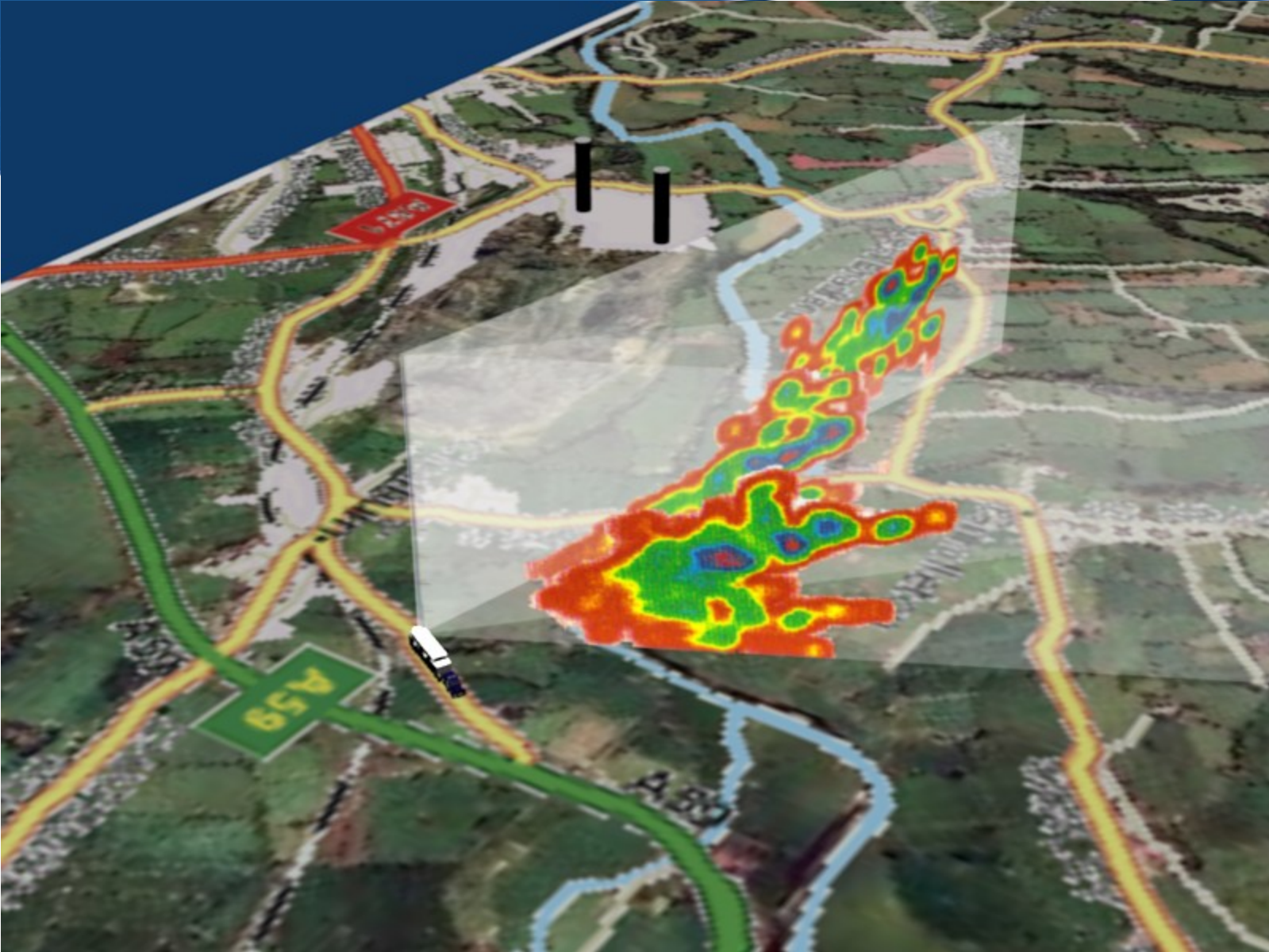

Examples of site survey

- Following slides show DIAL scans made at a crude oil gathering station
- Illustrate the ability of DIAL to show spatial information on sources emissions and determine site wide emission flux

Plant survey

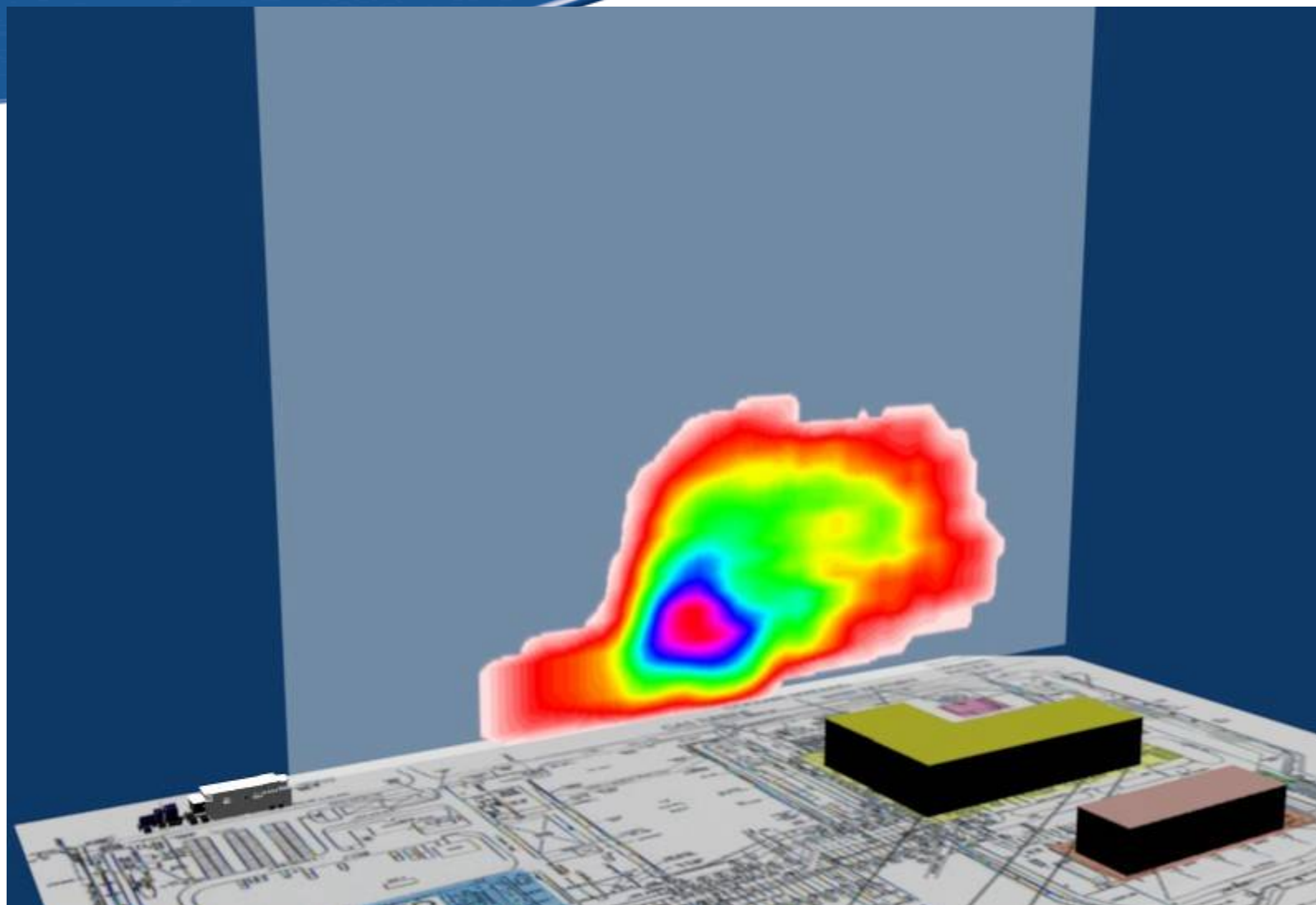

Plant survey

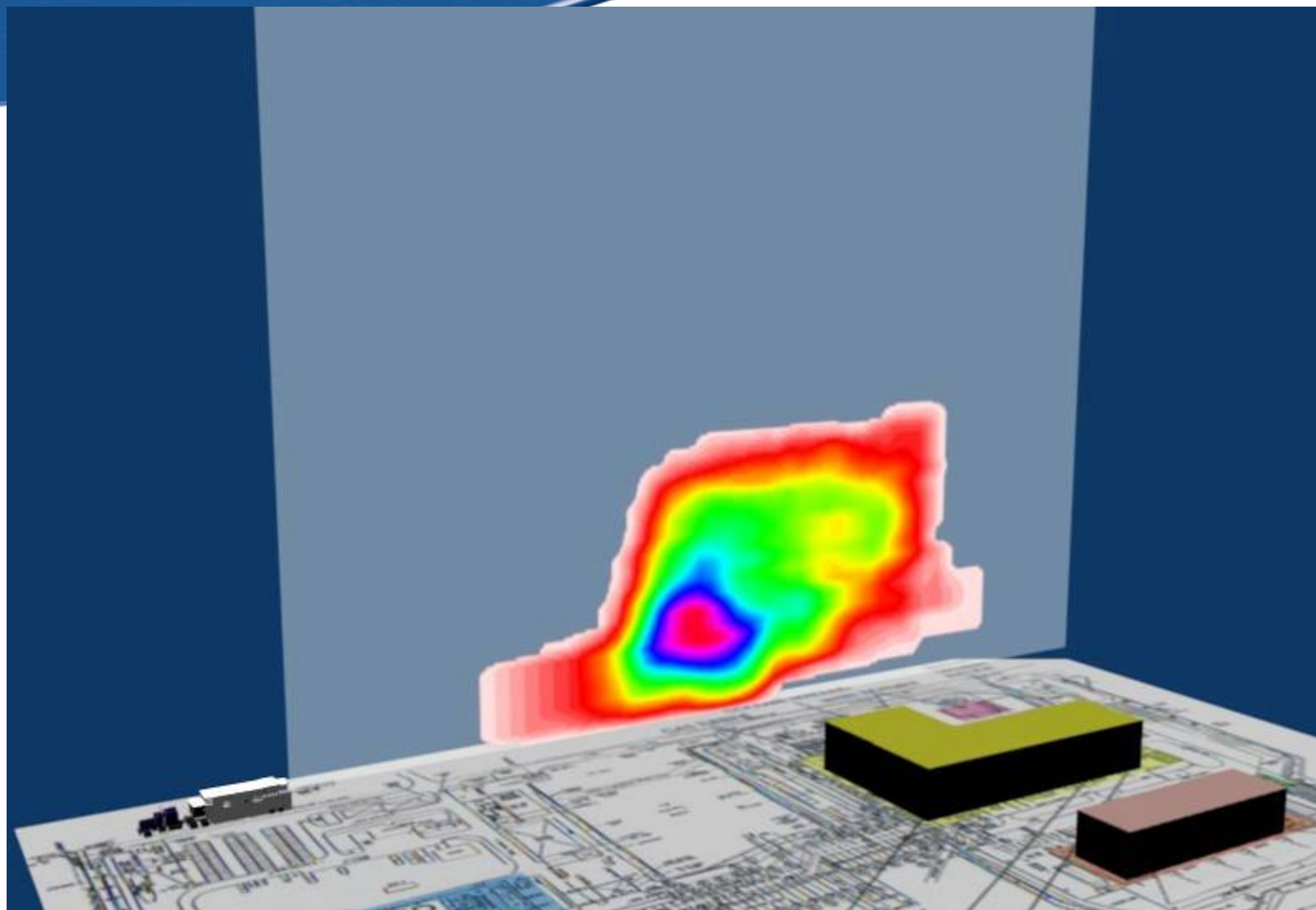

Plant survey

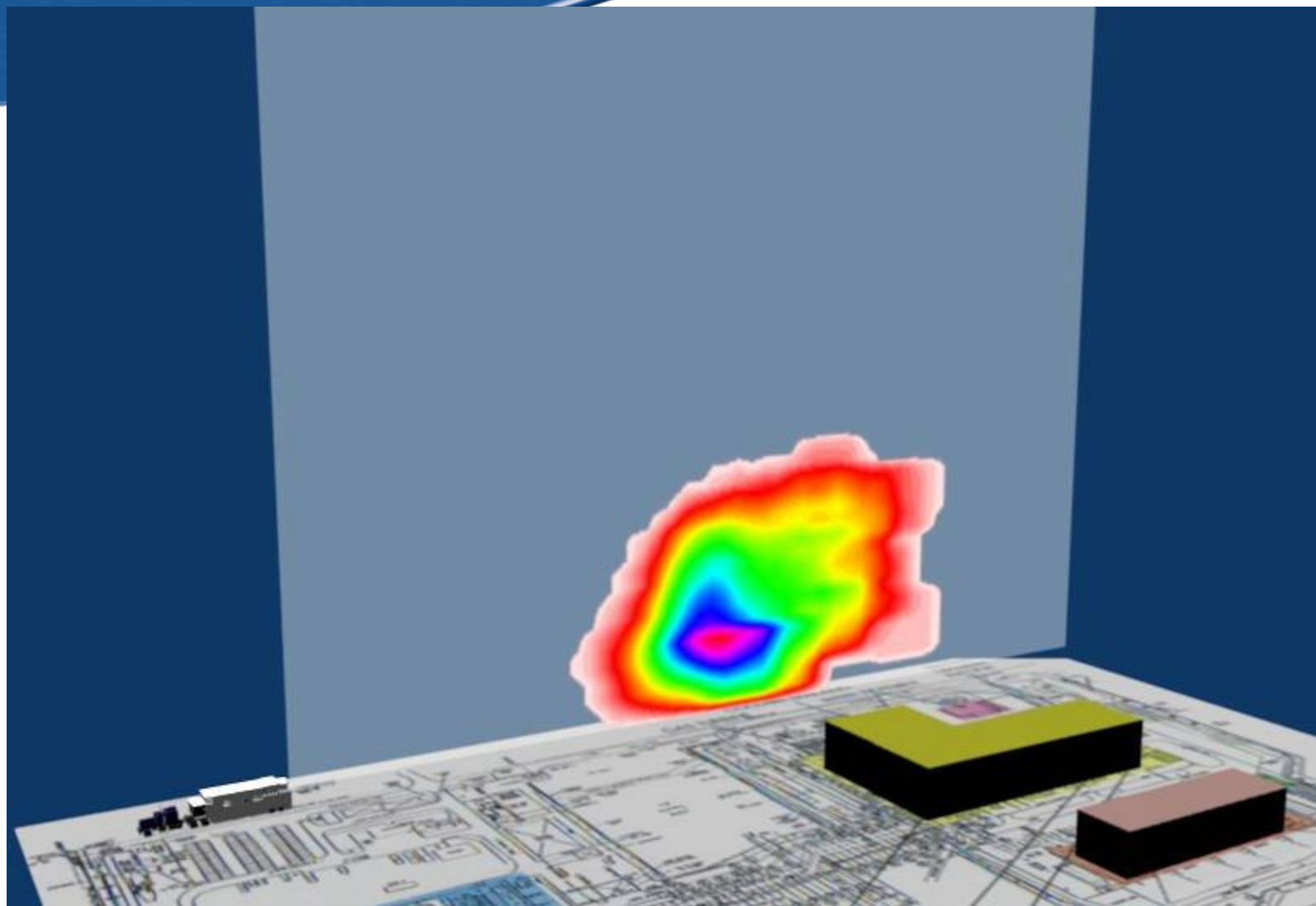

Plant survey

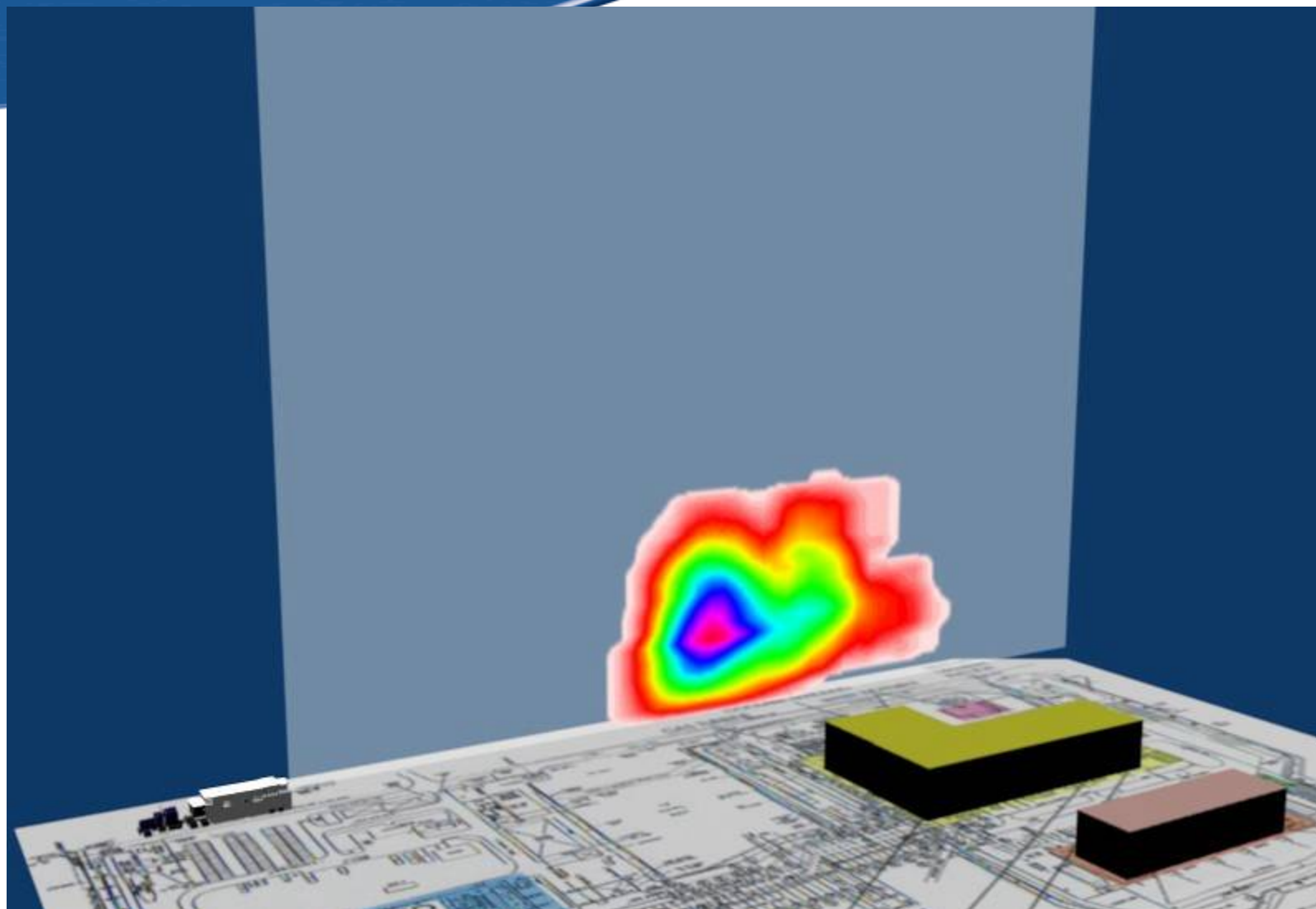

Plant survey

DIAL moved to new location,
New measurement plane allows tracking of plume through site
(move takes ~20 minutes)

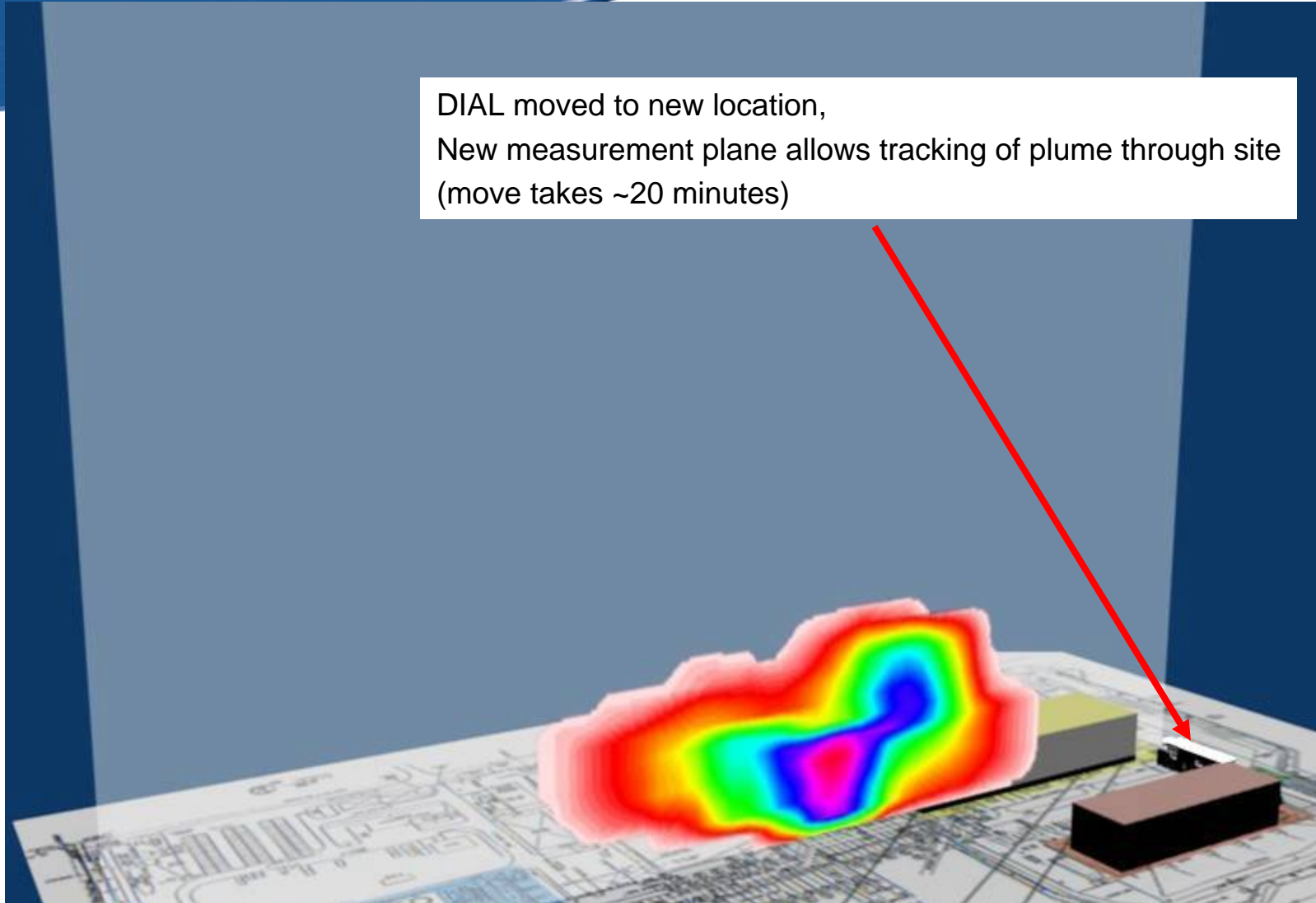

Plant survey

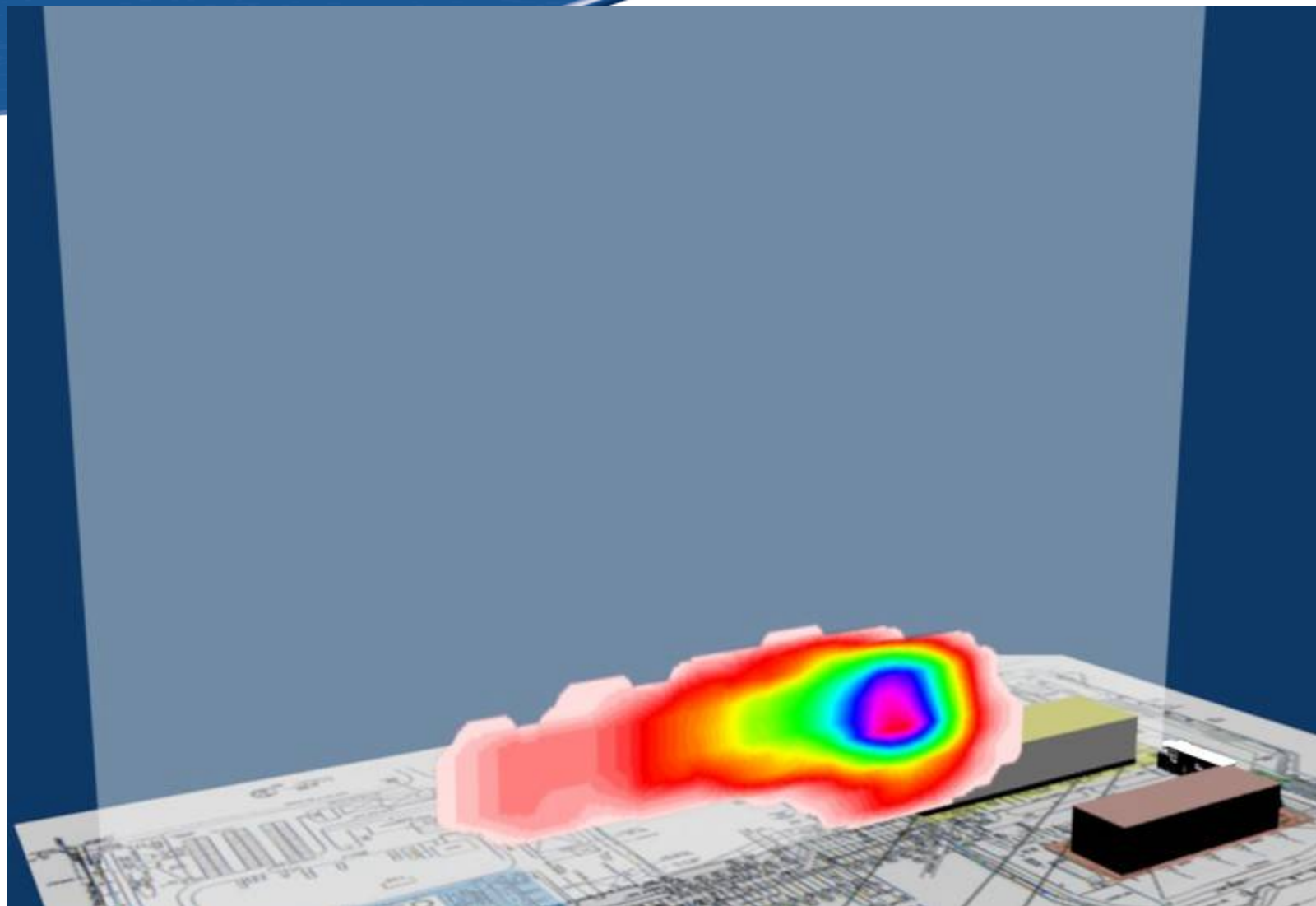

Plant survey

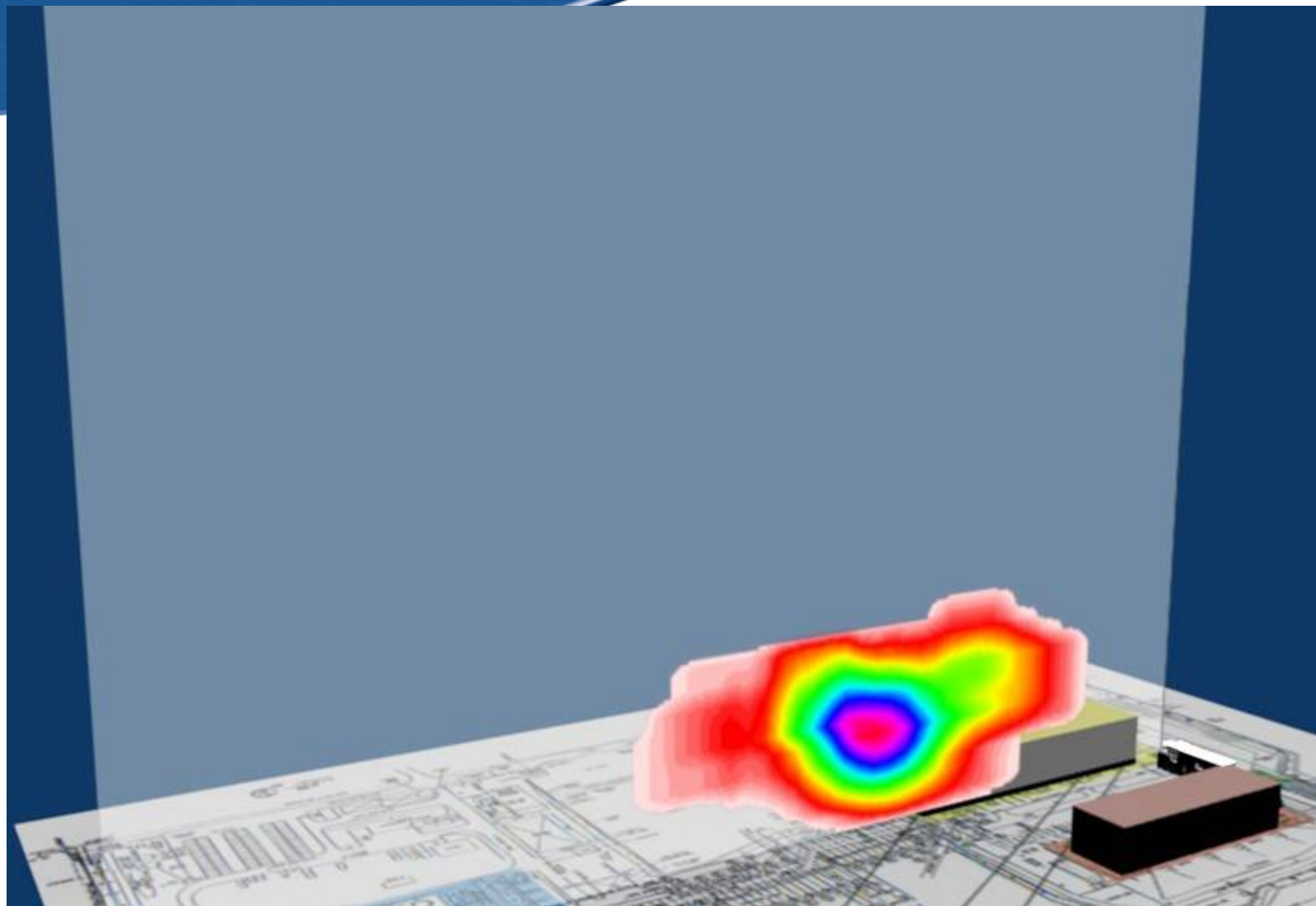

Plant survey

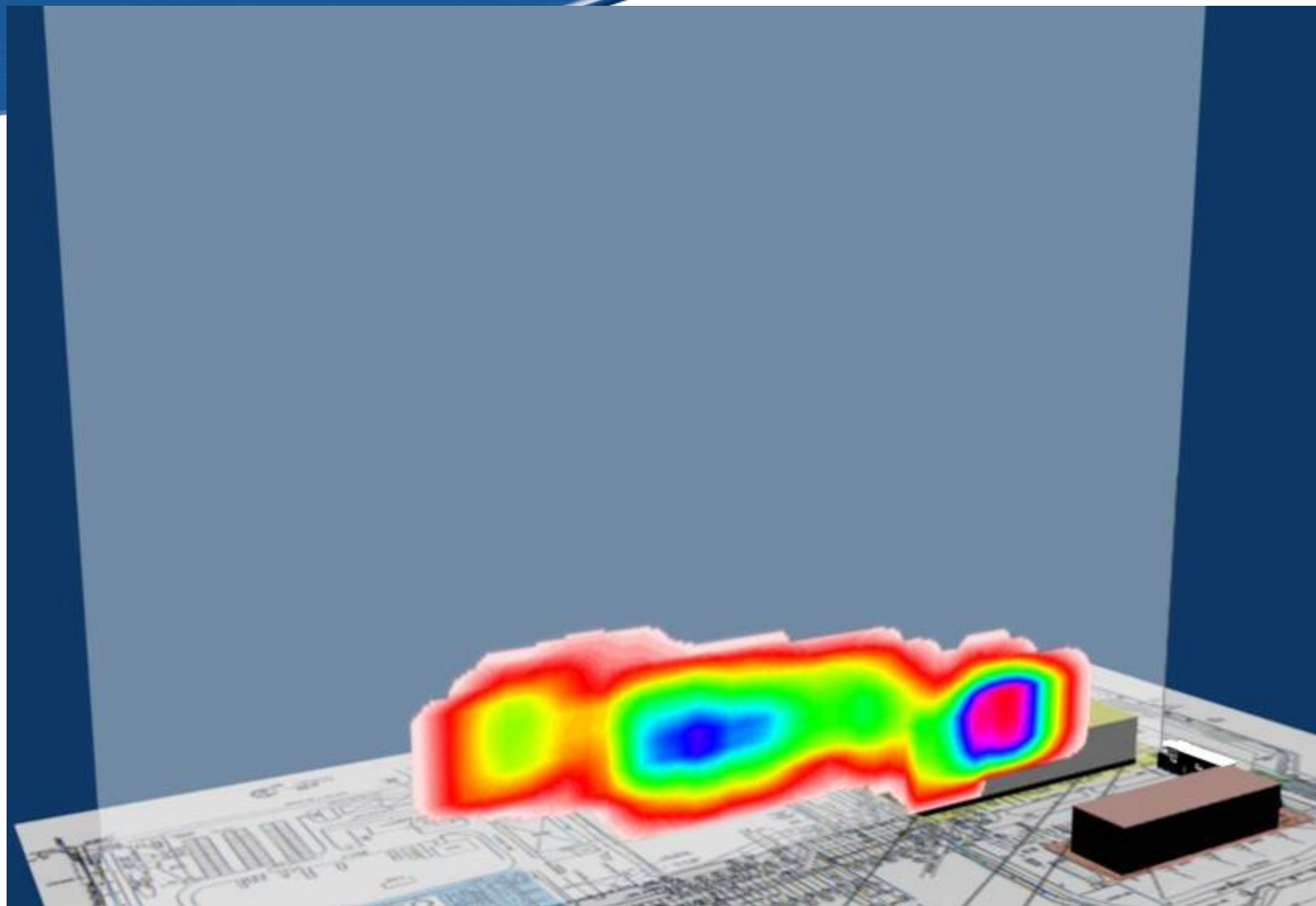

Plant survey

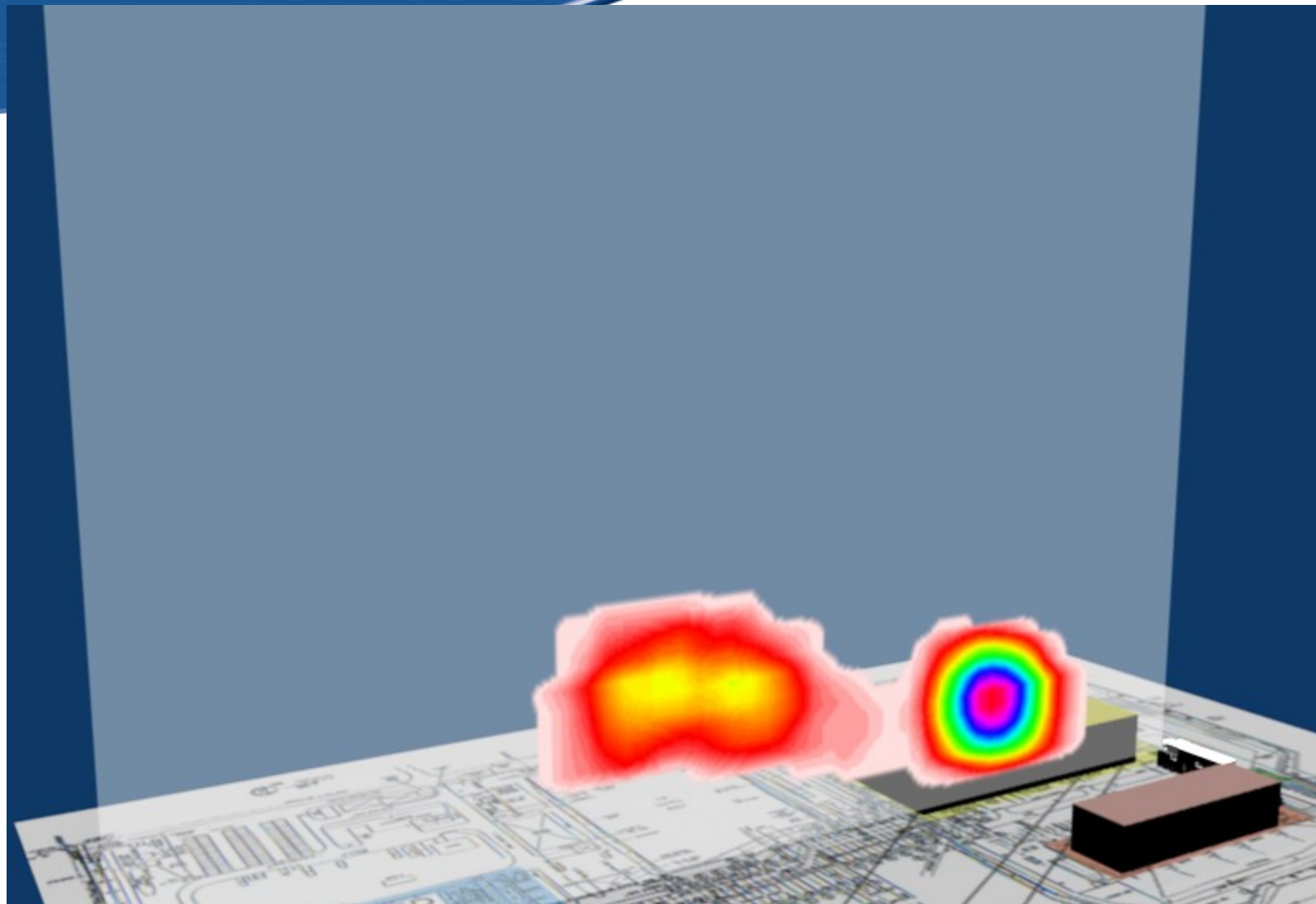

Total Site Emissions for Regulatory Monitoring

- Carried out measurements of emissions from plant and storage at an oil installation
- Required by UK regulators to demonstrate boundary fence emission flux and concentration levels
- Measured vent stacks, flare, process plant, tankage, power plant
- DIAL measurement report used by plant operator to submit to regulator
- DIAL measurements are accepted for routine measurements in the UK

Comparison between DIAL and point samplers with reverse dispersion model

- Carried out in Netherlands for Dutch government
- Comparison between DIAL and point samplers for flux measurements
- Comparison showed reasonable agreement on average, though individual comparisons could vary by factor of 2
- Interesting note made on costs of the methodologies
 - DIAL cost higher, but it was able to measure under more conditions, and provided more data, when costs were compared pro rata with number of measurements (of flux) then costs were comparable.

UK Regulator's use of DIAL

- Environment Agency of England and Wales view DIAL as a very powerful tool, primarily used in high profile cases where other techniques have not resolved the issue – ‘a campaign tool’
- Potential uses for
 - Model validation
 - Emissions monitoring for specific cases – emissions performance
 - Estimate validation – ‘air truthing’
 - GHG's
- Skill base of teams using it is important as well as the equipment

Summary of findings

- Often identify emissions which are not known to the operators.
- These are, almost by definition, usually outside any LDAR programme, and so would likely remain 'unknown'
- The occurrence of 'abnormal' operating conditions is almost the norm
- Wide range of emissions factors observed –
 - Average ~ 0.2 % total throughput, range 0.07% – .3% for refineries
 - 0.5% for gas terminal
 - 0.04 crude gathering

Where next with the technology?

- Lidar Instrument for FAAM Research Aircraft
- 5 wavelength airborne DIAL system
- Vertical profile information
 - Water vapour
 - Ozone
 - Aerosols

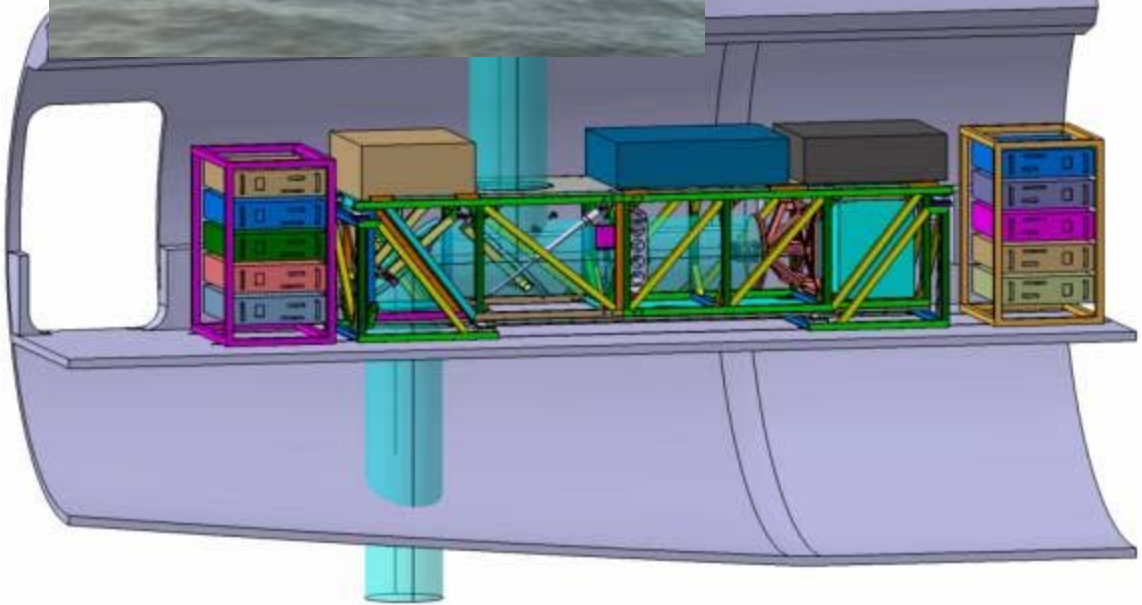

DIAL Emissions Monitoring in
Sweden
Lennart Frisch, Agenda Enviro
AB, Sweden

LENNART FRISCH

Agenda Enviro AB

info@agendaenviro.com (or .se)
www.agendaenviro.com (or .se)



Agenda Enviro

Personal background

M.Sc. Chemistry and Physics
Process Engineer Oil refinery
Environmental head officer Provincial Government/County Administration
National advisor on process industry environmental issues
Member of Swedish EPA national board on industrial compliance control
Member of Swedish EPA Scientific Committee on Air quality
Swedish representative to the EU commission on environmental legal enforcement (IMPEL)
Swedish representative to the EU commission on Environmental Management (EMAS/ISO 14 001)
Certified environmental lead auditor according to ISO 19 011 (14 001, 9001)
Member of board for Swedish Clean Air Association



Agenda Enviro

Background to measurements

Mass balance loss data

Company resistance

Public anxiety

Measure optimization

SF₆-experience

All information in the public domain



Agenda Enviro

Enforcing measurements

- Enforcement authority competence to claim control measures on behalf of company cost
- Initial decision January 1988 on highest regional level
 - Fee of 300 000 \$
 - Geographical prerequisites (topography, up-wind concentrations)



Agenda Enviro

I WILL SHOW

1. How wrong **calculations** are, giving **rigid** and **far too low emission values**
2. That the **focus calculations** give on process area emissions **rarely is the true picture**, heavily underestimating other emissions sources



Agenda Enviro

VOC-emissions

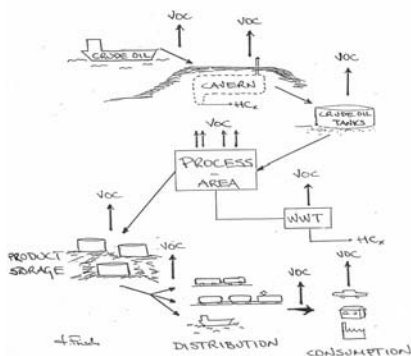

Agenda Enviro

DIAL - Site Measurement

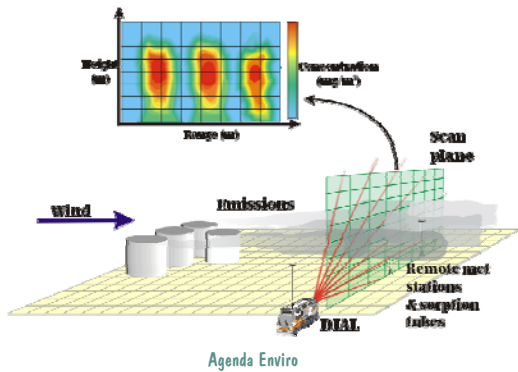

DIAL Vehicle



BP/OK/Preem Refinery Emissions 1988 - 1999

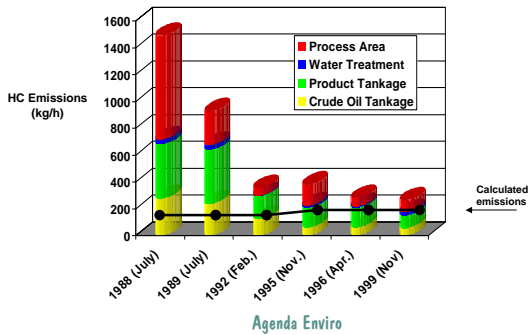

Measurements show decreasing values due to forced measures to reduce emissions, whereas calculations show increasing emissions due to expansion of the plant, not being able to take improvements into account

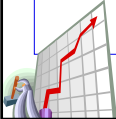

Agenda Enviro

Initial measurements were only alkanes $C_3 - C_8$.
 With new technology including BTEX and $C_2 - C_{15} \rightarrow$
 measured old emissions are expected to be
50 – 100% higher



Agenda Enviro

Changing true emissions from tanks

Tanks with outer floating roofs	Year of DIAL-measurement		
	1992 (factor)	1995 (factor)	1999 (factor)
Gasoline tanks	2,7	2,0	2,4
Gasoline component tanks	1,9	1,7	2,2
Crude oil tanks (Tk-1401 and Tk-1402)	26	2,6	13
Crude oil tank (Tk-1406)	-----	1,1	52



Agenda Enviro

Impact on emissions due to tank pumping operations

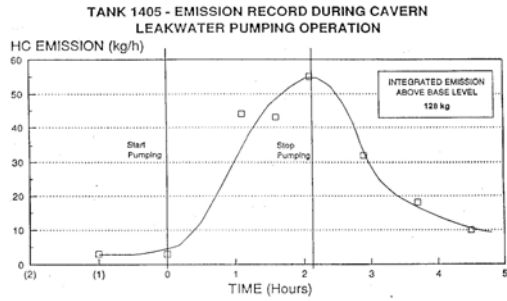

Agenda Enviro

Impact of floating roof height on emission levels

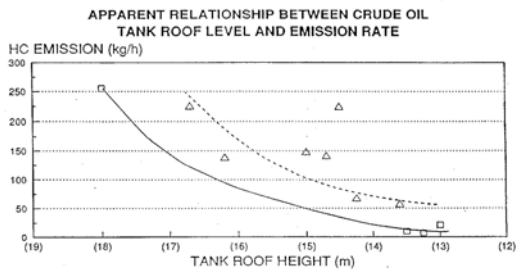

Agenda Enviro

Reducing tank emissions by identifying true emissions

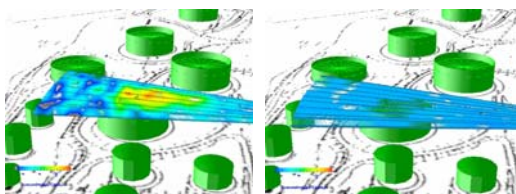

Before

After

Agenda Enviro

Emissions distribution on main refinery areas

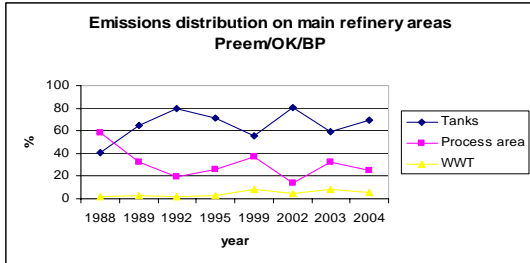

Agenda Enviro

Emissions distribution on main refinery areas

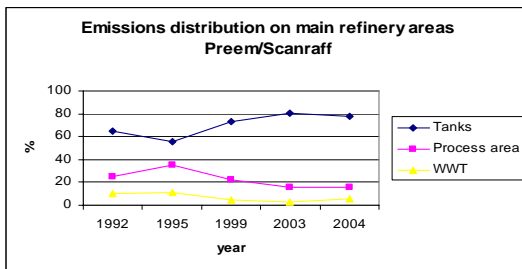

Agenda Enviro

The **Process Area** only makes out one source of emissions (15 – 40%).

The main emissions normally stem from **Tank Storage** (40 – 80%)!

WWT accounts for some 5 – 10%.



Agenda Enviro

Emissions Comparison

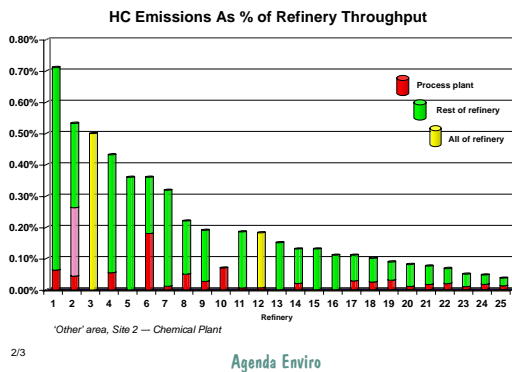

Comparisons – Measurements (DIAL) - Calculations

	DIAL measurement (kg/h)	Calculation (kg/h)
Preem (BP) 1988	1489	83
Preem 1999	263	106
Danish refinery 1995	720 (HC+B)	~40
UK refinery 1993	6000+ 6700+ inc crude oil tanks	230 – 460 (Radian)
Worst case calculation Crude Oil Tank 100m diameter		42
Isomerase tank 50m diameter	200 – 450	
Crude oil tank 90m diameter	250	
Belgian refinery (2 Mt/a)	1570	1370 (total from 5 refineries)

Agenda Enviro

Typical main incidents experienced by measurements:

- One **single leak** in process area (4 000 tons/a)
- Splitter malfunctioning causing massive emission at storage (**LPG In heavy product**)
- High roof level** for tank with outer floating roof
- Malfunctioning **outer floating roof sealing** (10 - 50 times up)
- Well (single) and tank within **WWT not covered**
- Leak from **rock cavern** (800 tons/a)

Agenda Enviro



Measurements give true emissions !



Calculations give false and rigid values, related to only very well maintained or brand new equipment “all over”, missing nearly all impact of **real operations**

Agenda Enviro

REASONS FOR MEASURING

- Operations vary in time (Tanks, Process, WWT)
- Sudden Leaks (combination with LDAR)
- Ageing of Equipment
- Elevated temperatures in storage tanks
- Liquids heavier than kerosene
- Cost-effective reductions identified**



Agenda Enviro

In Europe this has amongst others meant that the **protocol on reduced VOC-emissions** will be difficult to reach and to work with due to:

- 1. too low initial emission data**
- 2. problems in presenting new data**
- 3. unclear focus when introducing measures to reduce emissions**



Agenda Enviro

Continued measurements

Frequency – Initially every 3rd year

Annualization – All year round
(Tank Storage, WWT, Process Area Close Down/Start Up)

Each plant treated individually
based on cost-benefit analyses →
i.e. no general protocol,
no exact emissions limits

Data used for emission inventories



Agenda Enviro

BP/OK/Preem Refinery Emissions 2002 - 2004

(alkanes only, measured by SOF)

Source	Emission 2002 (kg/h)	Emission 2003 (kg/h)	Emission 2004 (kg/h)
Crude-oil tank-park	147.9	78.8	116.5
Process	56.6	74.5	76.7
Product Tank-park	171.9	57.1	94.7
Water treatment facility	18.8	19.4	18.2
Total:	395.2	229.8	306.1

Total (ton/a) 3 460 2 010 2 680

Agenda Enviro

Measurement techniques

**SOF (Solar Occultation Flux) –
FTIR (2-/3-dimensional)**

**Truck driving along
a path using the
sun as driving force**

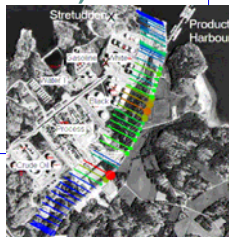

Agenda Enviro

Measurement techniques

DIAL (Differential Absorption Lidar)
Laser (3-dimensional)

Any plane can be chosen
(horizontal, vertical)

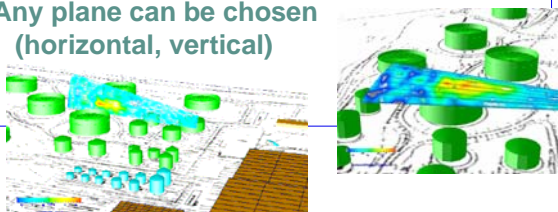

Agenda Enviro

Apart of the main measurement
device the following is also needed:

Meteorological data (distribution in height/surface/time)

Devices to measure **hydrocarbon distribution**

- molecular weight – typical $C_2 - C_{15}$ and
- type of hydrocarbons: **alkanes, alkenes, aromatics, cyclopentanes** etc.)

Place to stay for measurements



Road to drive along (SOF)

Stable wind conditions (SOF)

Sun (SOF)

Agenda Enviro

Report (pdf)
by the Swedish County
Administration of Västra
Götaland, Göteborg
(Länsstyrelsen),

#2003:56

(www.o.lst.se)



Agenda Enviro

LENNART FRISCH

Agenda Enviro AB

info@agendaenviro.com (or .se)
www.agendaenviro.com (or .se)



Agenda Enviro

Ambient VOC Monitoring in Fort Saskatchewan and the Potential Impact of Fugitive VOC

Emissions

Curtis Englot, Environment
Canada

Ambient Air VOC monitoring program in the area of Fort Saskatchewan, Alberta, Canada and the potential implications to fugitive VOC emissions

Curtis Englot
October 26, 2006

VOC Ambient Monitoring



Environment
Canada

Environnement
Canada

Canada

Outline

- VOC Monitoring Study – Location and Sampling Methodology
- VOC Monitoring Study Results
- Environmental Performance Agreement
- EPA 1,2-DCE Results
- Modelling and Fugitive Releases
- Reports
- Principle Component Analysis
- Conclusions

VOC Monitoring Study - Location

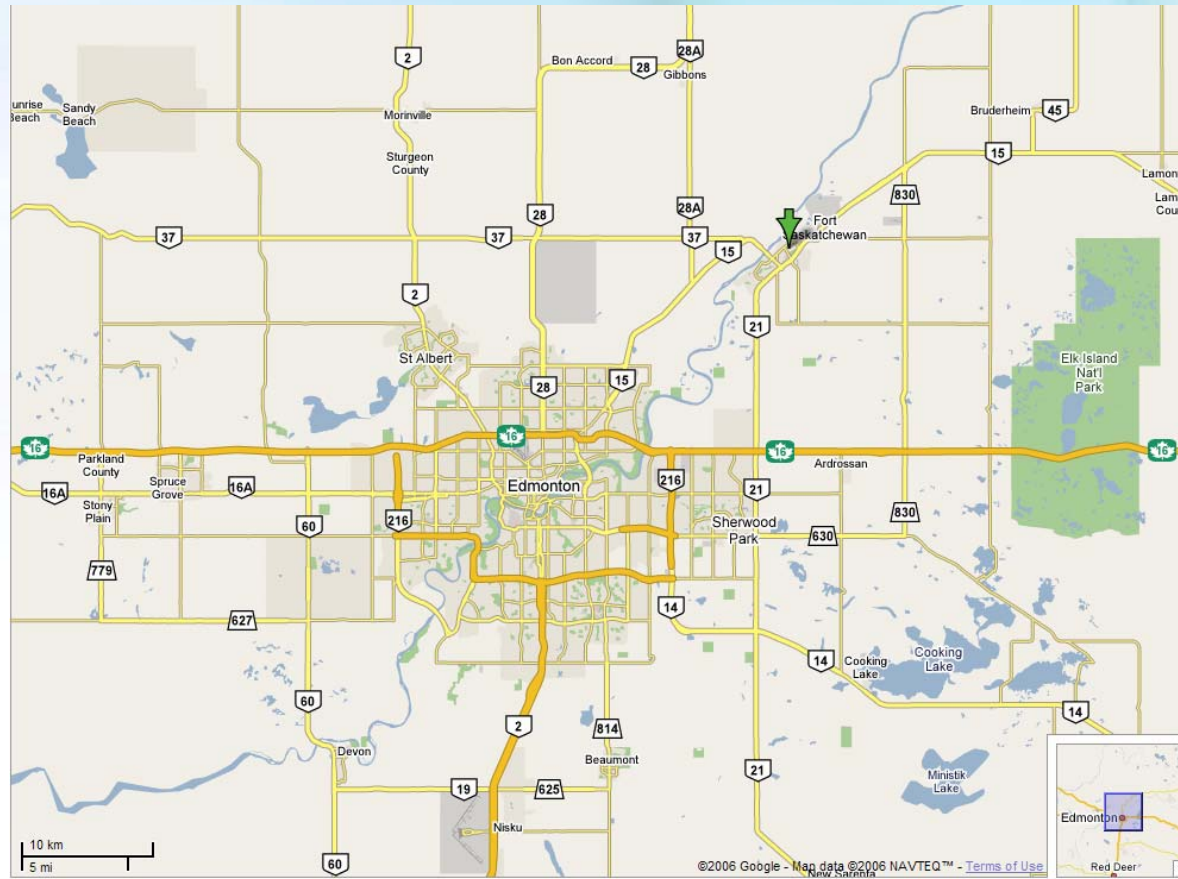

December 22,
2006

Page 3

VOC Ambient Monitoring

VOC Monitoring Study - Location

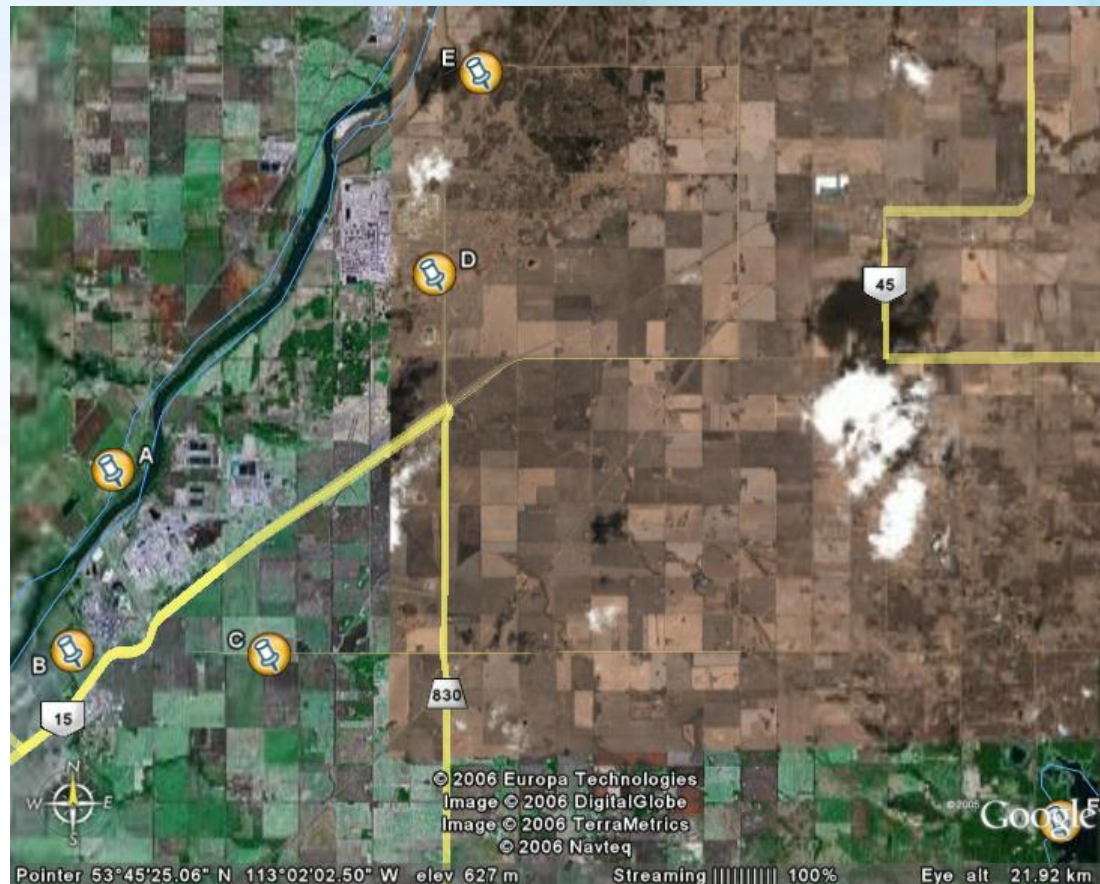

December 22,
2006

Page 4

VOC Ambient Monitoring

VOC Monitoring Study - Location

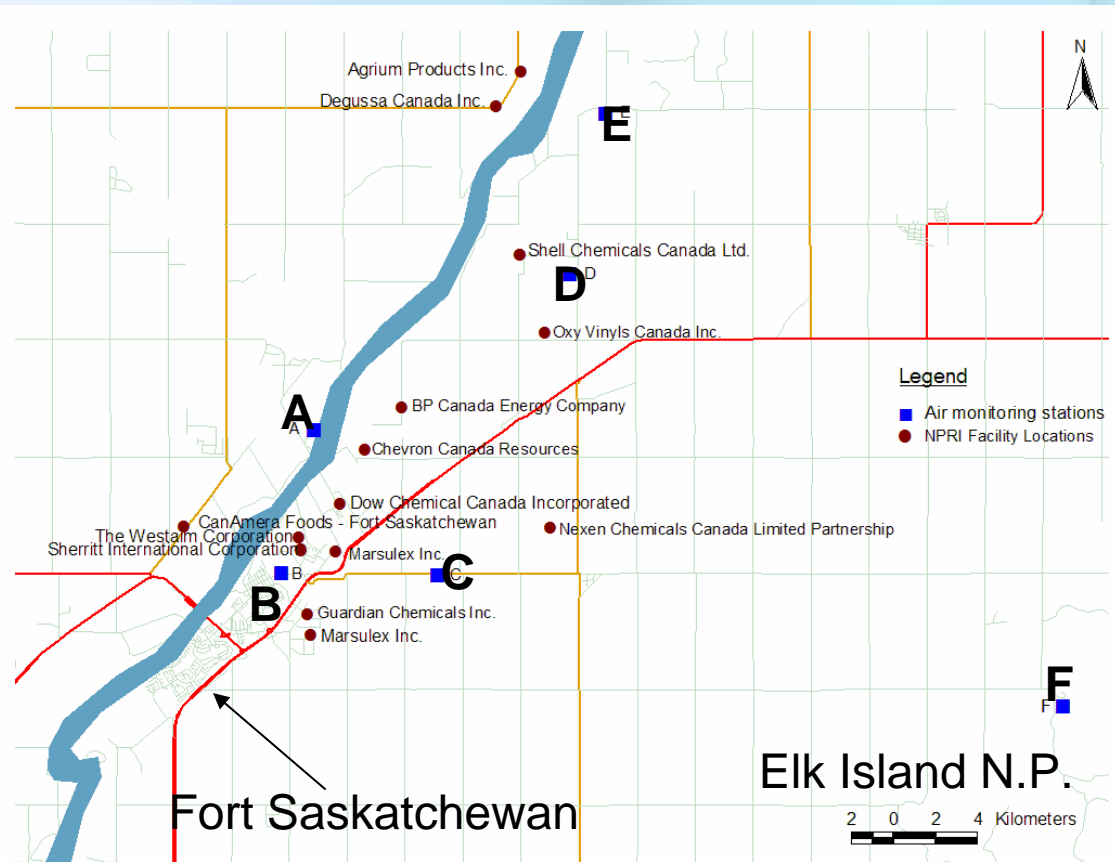

VOC Monitoring Study - Methodology

- Sampling from September 12, 2004 to March 31, 2006.
- 150 VOCs
- 24-hour samples taken every 6 days according to National Air Pollution Surveillance (NAPS) protocol
- Summa canisters using mass flow controllers and Xontech samplers
- Samples sent to ETC in Ottawa for GC-MS



Results - Criteria

- 537 sampling canisters, 95 sampling days.
- Comparison to Ontario Ambient Air Quality Criteria/ Standards (OAAQC/S).
- 36 substances have OAAQC/S.
- 10 days with elevated 1,2-dichloroethane concentrations, below the OAAQC/S 90% of the time.



Results - Total VOCs

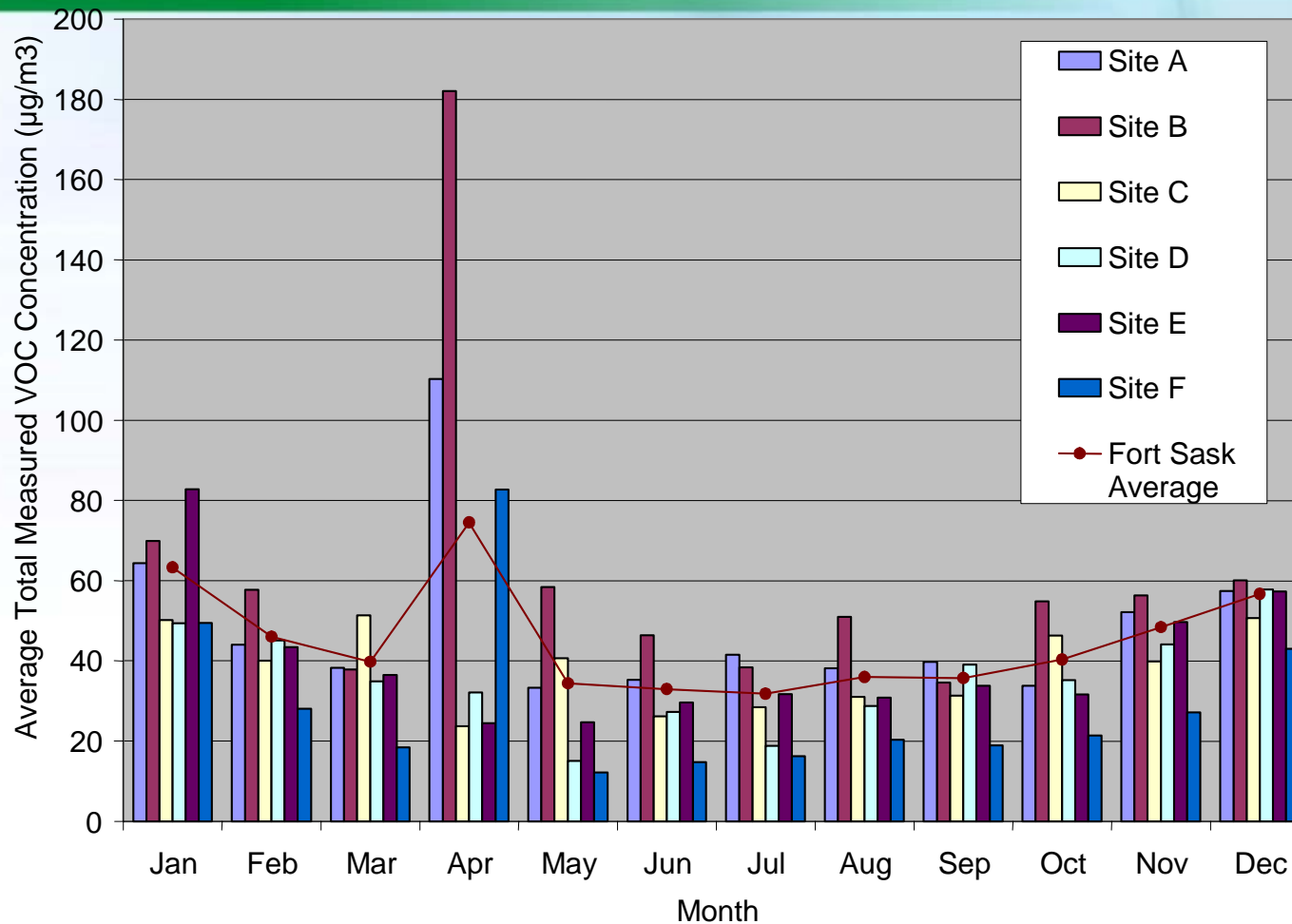

Results – Comparisons

- Lack of standards so compared to 6 NAPS urban sites (Group Average).
- 8 VOCs higher than the “*Group Average*” :

1,2-dichloroethane

vinyl chloride

1-hexene/2-methyl-1-pentene

4-methylheptane

2-methylhexane

heptane

3-methylhexane

p-cymene

- Of the 8 substance, 4 had unique events that impacted the overall average and distribution.
- Remaining 142 VOCs lower than “Group Average”.



Results – Unique Events

- Days of Interest:
 - Oct 30, 2004 – associated with town sources
 - Jan. 28, 2005 – releases from oil and gas wells to NE.
 - Numerous days – temperature inversions have a large effect.
 - April 10, 2005 – planned flaring.
 - May 22 and Oct. 1, 2005 – high 1,2-DCE values.

Results – Unique Events

- Days of interest (continued):
 - Oct. 31, 2005 – vegetative activity
 - Nov. 24, 2005 – high 1,2 DCE reading at three sites



1,2-Dichloroethane EPA

- 1,2-DCE is a toxic substance under the Canadian Environmental Protection Act (CEPA 1999)
- Only producer in Canada located in Fort Saskatchewan
- Undertook emission reduction activities in 2001 to manage releases through Environmental Performance Agreement.



1,2-Dichloroethane EPA

- Equivalent performance to National Emission Standard for Organic Hazardous Air Pollutants (NESHAP) from the Synthetic Organic Chemicals Manufacturing Industry (SOCMI).
- Emission reduction plan.
- Ambient fence line monitoring program.



EPA Results - 1,2-Dichloroethane

- Ambient fence line values were higher than expected in 2002.
- Lead to more detailed ambient air monitoring program at receptors.

	2002 Summer		2004 Summer		2004 Winter		2006 Summer	
	Block 60	Block 370	Block 60	Block 370	Block 60	Block 370	Block 60	Block 370
# of Samples	11	11	11	11	11	11	11	12
# exceeding Ontario limit (2 ug/m3)	2	3	6	7	0	5	2	7
Max (ug/m3)	11.62	8.10	7.57	30.81	<MDL	6.40	8.50	113.37
Min (ug/m3)	<MDL	<MDL	<MDL	<MDL	<MDL	<MDL	<MDL	<MDL
Mean (ug/m3)	2.37	2.17	2.60	8.19	<MDL	1.92	1.58	26.05
Std Dev (ug/m3)	4.21	3.16	2.03	11.00	NA	1.90	2.46	36.72

VOC Results - 1,2-Dichloroethane

1,2-Dichloroethane: All Sites

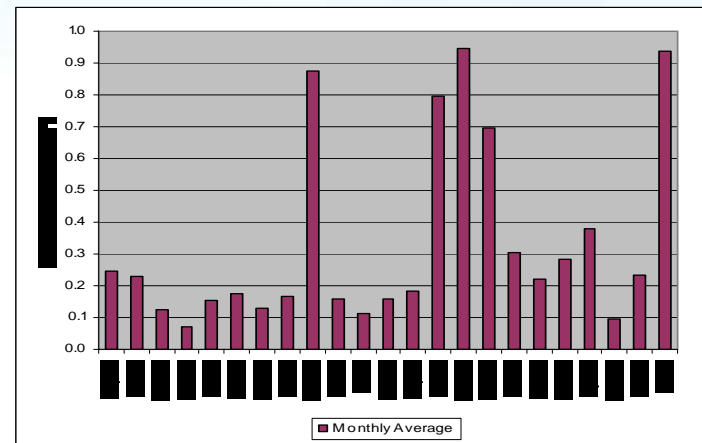
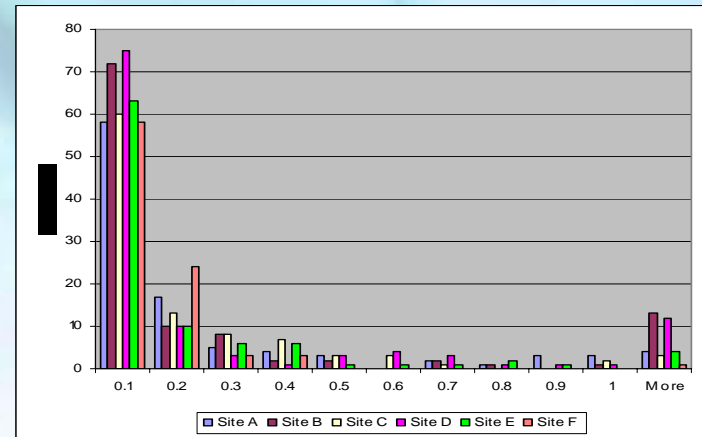
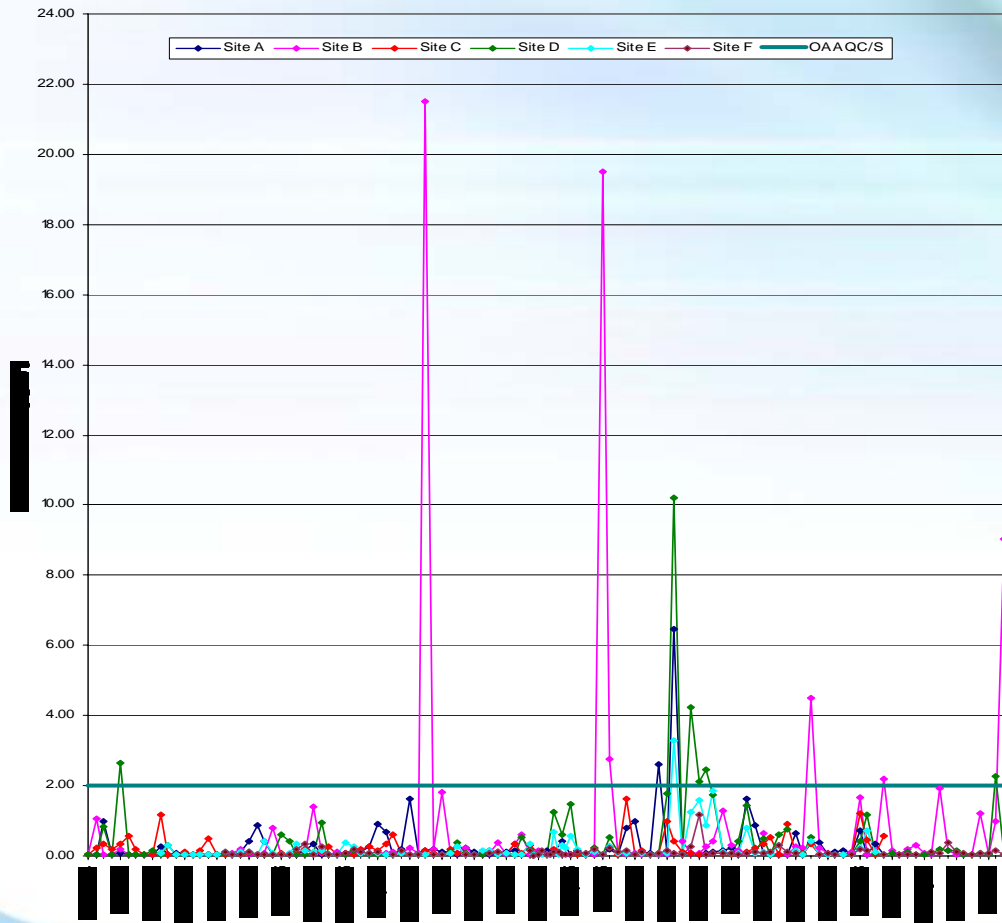

High 1,2-DCE investigations

- 1,2-DCE concentrations:
 - May 22 - Site B = 21.51 $\mu\text{g}/\text{m}^3$
 - Oct. 1 - Site B = 19.49 $\mu\text{g}/\text{m}^3$
 - Nov. 24
 - Site A = 6.45 $\mu\text{g}/\text{m}^3$
 - Site D = 10.19 $\mu\text{g}/\text{m}^3$
 - Site E = 3.29 $\mu\text{g}/\text{m}^3$

High DCE investigations

- Met with company to determine if any operating conditions could explain.
- First result was questioned as bad data.
- Second result partially attributed to routine activity.
- Third result unknown.

Modelling

- Lagrangian Stochastic MLCD model by Canadian Meteorological Centre.
- Models 1 unit of material release.
- Simply multiply measured results to determine source strength.
- Nov. 24 and May 22 were modelled.

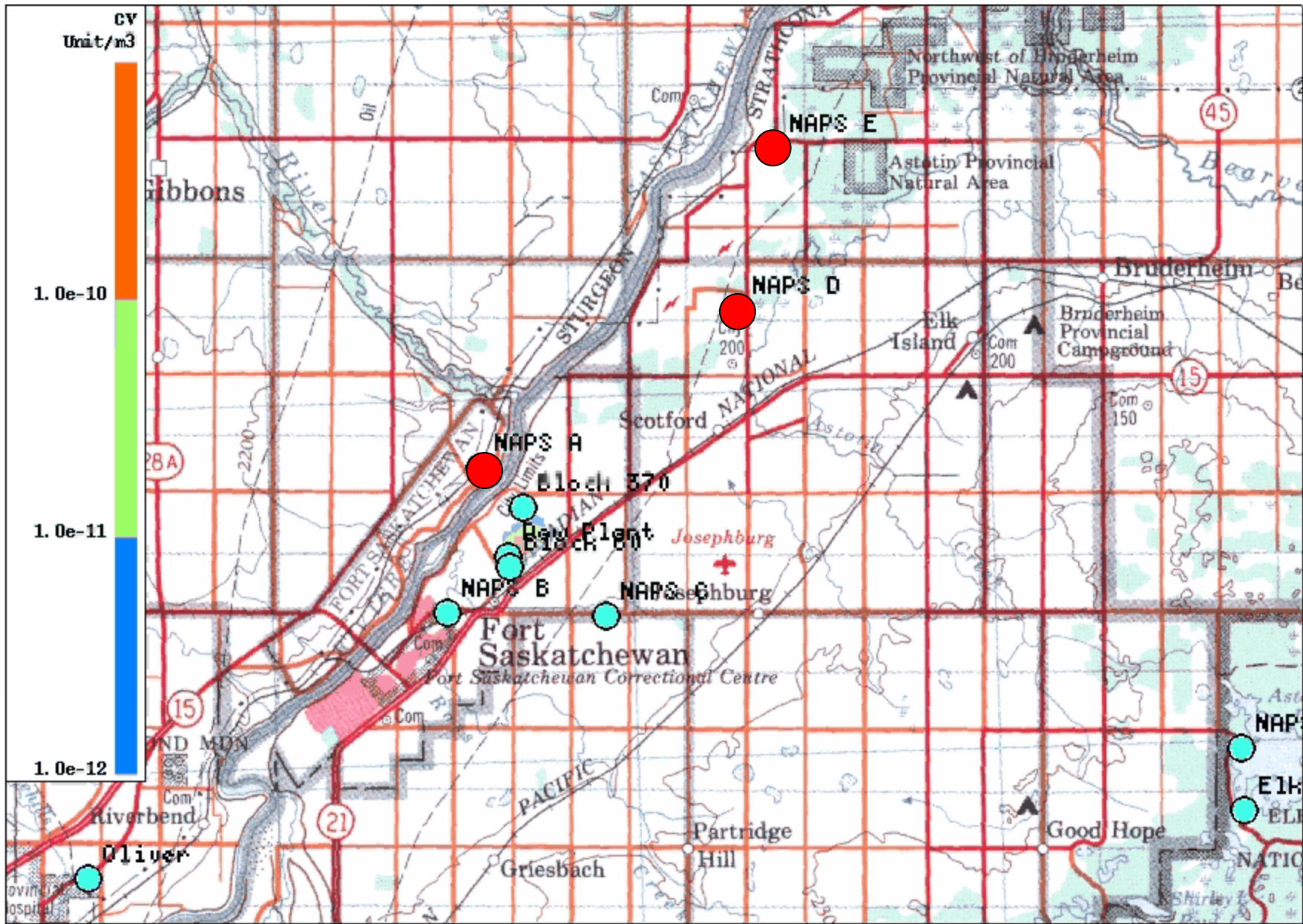

Jeudi 24 Novembre 2005 à 16:10Z

Modelling Results

- Source strength on Nov. 24 between 50 kg/hr and 100 kg/hr
- Source strength on May 22 = 100 kg/hr

Feasibility of Modelled Results

Emissions Method	Rate
NPRI Reported 7791 kg/yr	0.89 kg/hr
0 – 1,000 ppm emission rate	1.7 kg/hr
Modelling Results	50 – 100 kg/hr
1,001 - 10,000 ppm emission rate	170 kg/hr



NPRI Reported Emissions

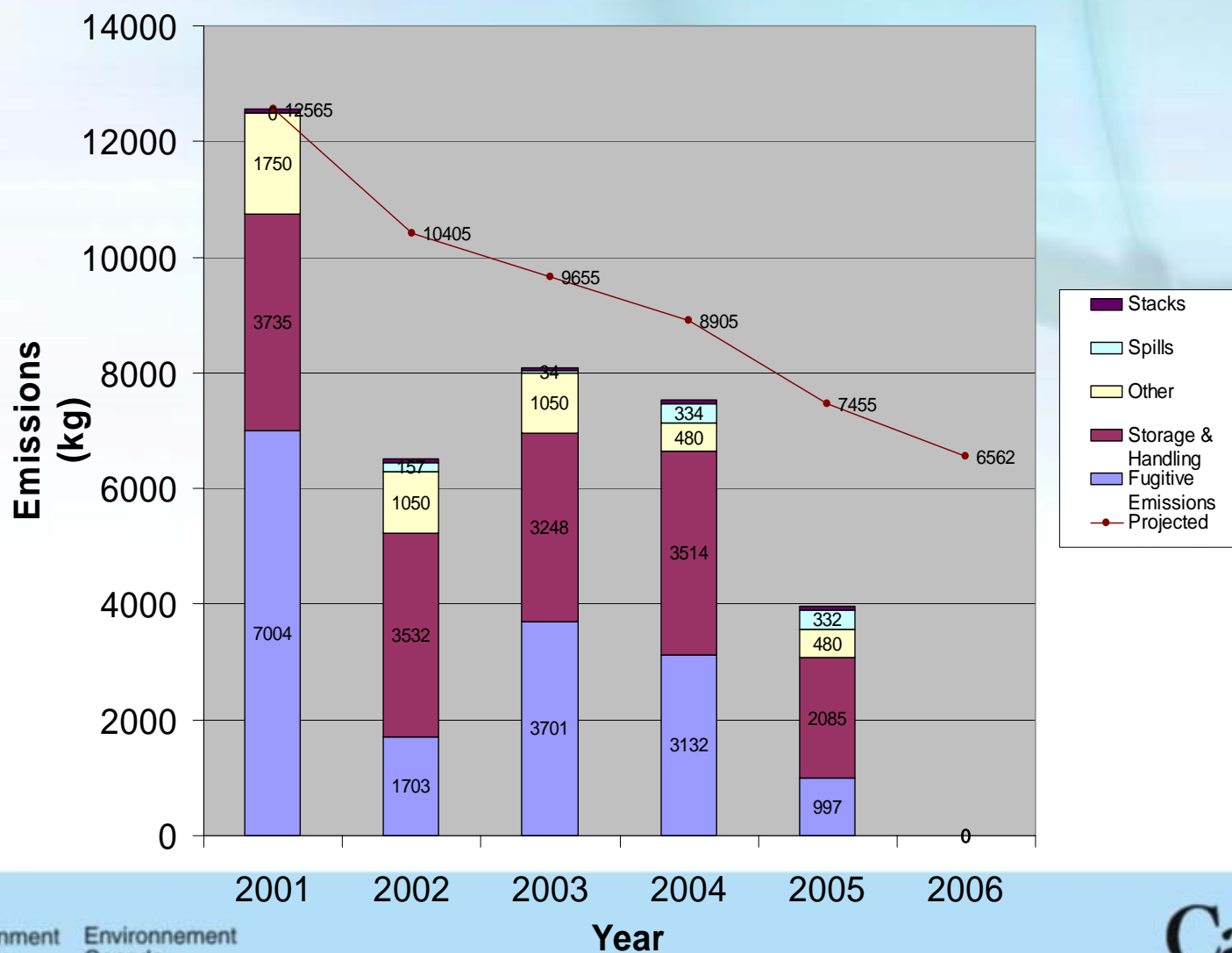

Ambient vs. NPRI reported

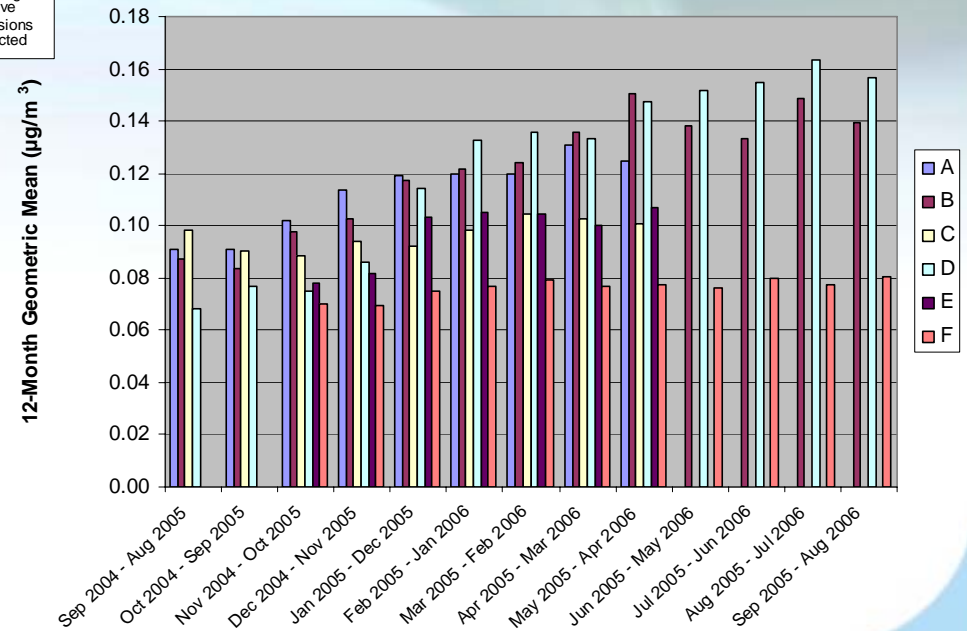
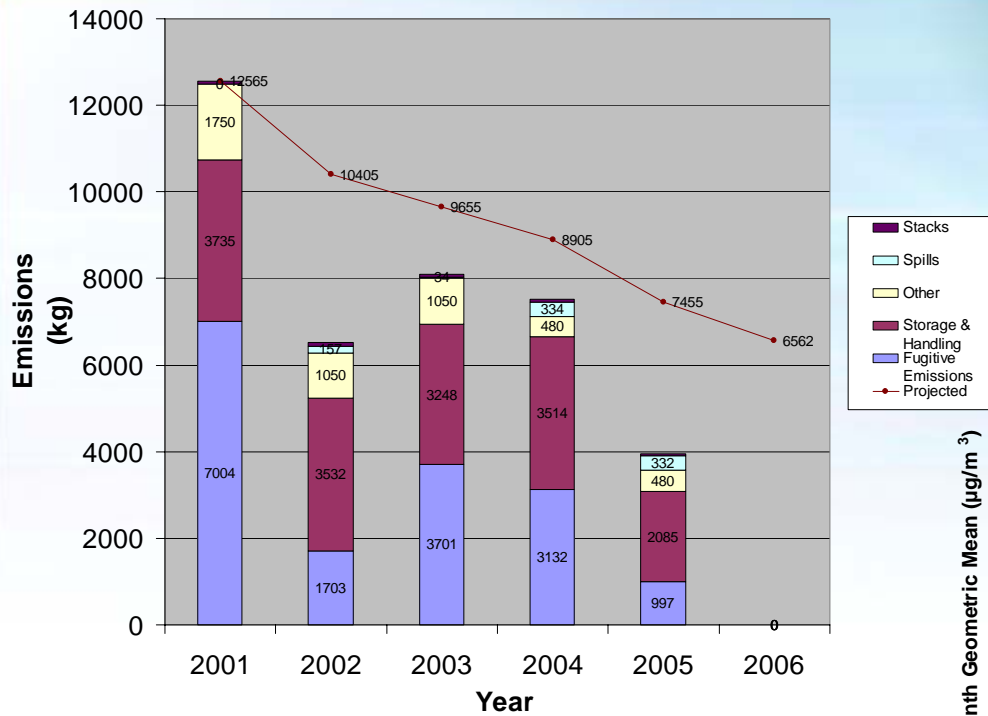

Fugitive Emissions

Component	Total	% Unmonitored
Valves	4,921	66.0
Pumps	114	12.2
PRVs	20	100
Connectors	26,238	67.5
OELs	54	20.0
Total	31,408	62

Storage Tanks

- Review revealed a seal was missing from one of the tanks.
- Calculation methods don't use actual measurements of emissions.
- Other results such as DIAL and emissions cameras have raised concerns about tanks.
- Results from North Vancouver shipping facility continue to be problematic.



Reports

- Want to know more?
- Data and reports can be found on the Fort Air Partnership's Website
- www.fortair.org/whats_new.php
- www.fortair.org/airquality_reports.php
- 3 Reports
- 1 Health Summary from Capital Health



Results – Principle Component Analysis

- PCA – multivariate statistical analysis method
- Examines underlying correlation in a subset of 30 VOCs of interest
- Extracts factors: groups of correlating VOCs
- Factors account for 80 – 84% of the total variance observed in this VOC subset



PCA Results - Site C - 1 Factor

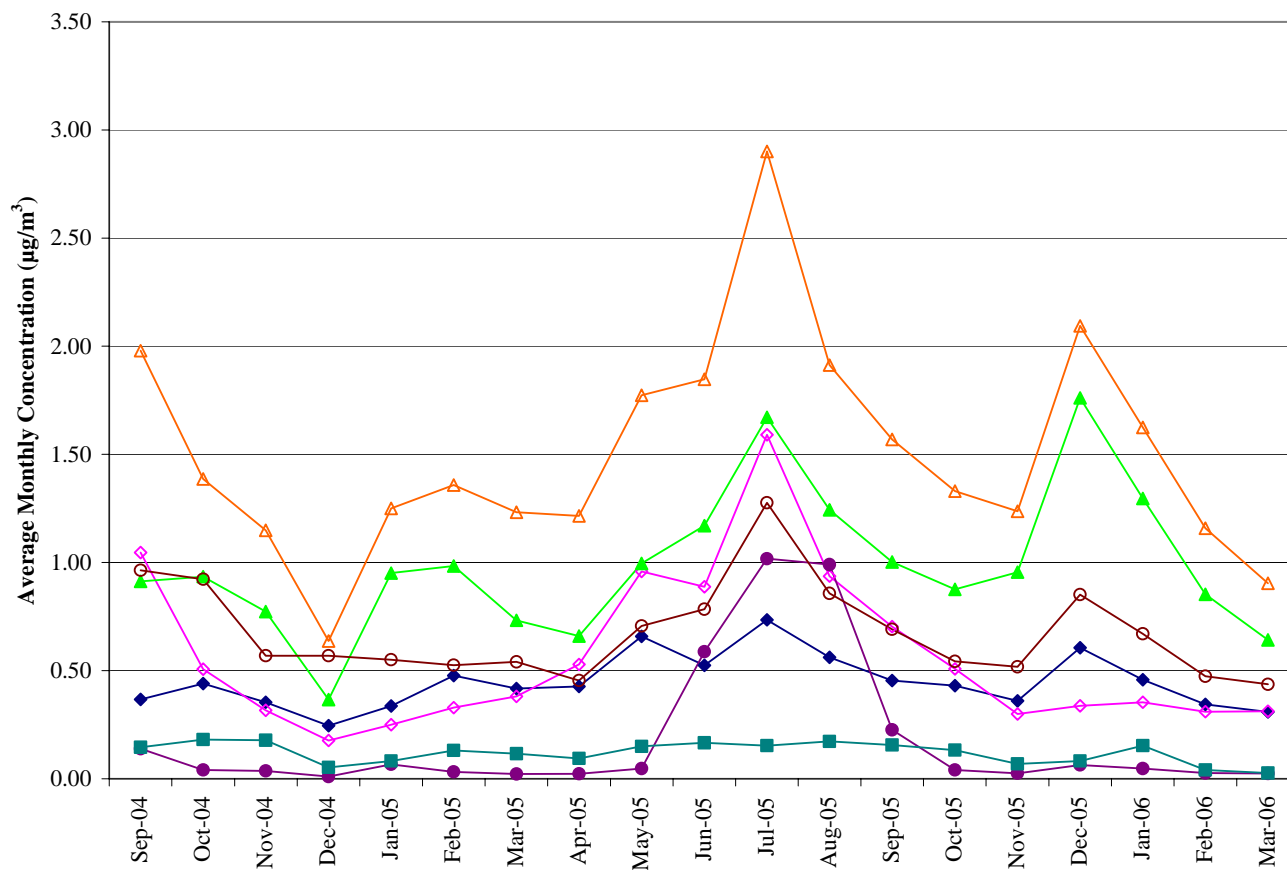

- 1-butene/2-methylpropene (◆)
- 1-hexene/2-methyl-1-pentene (◇)
- 2-methylpentane (▲)
- hexane (△)
- isoprene (●)
- methylcyclopentane (○)
- styrene (■)

Results – Principle Component Analysis

- Major factor: vehicle emissions and urban area sources (accounts for 36 – 44% of observed variance)
- Long range transport of stable VOCs such as CFCs (10 – 16% of variance)
- Specific factors of industrially produced VOCs (4 – 8% of variance)
- Correlation with wind direction—urban and industrial factors



Conclusions

- Ambient data suggests discrepancy with calculated emissions.
- Better means of determining emissions in needed.
- Need something practical.
- Ambient levels may be higher than expected and routine activities may have bigger impacts than expected.

API Critique on the Use of DIAL
for Quantifying VOC Emissions
Rob Ferry, API Consultant

EMISSION FACTOR UNCERTAINTY & the Role of Remote Sensing

Rob Ferry

The TGB Partnership

1325 Farmview Road

Hillsborough, NC 27278

(919) 644-8250 voice

(919) 644-8252 fax

Rob.Ferry@TGBpartnership.com

DISCLAIMER

I am a private consultant who does much of the emission factor development work related to storage tanks.

BUT:

I am *not* a representative of API or of any of its member companies.

AND:

The opinions that I express are strictly my own.

PREMISE

“Neglect of variability in the underlying parameters increases the potential uncertainty of an emissions estimate.”

If the variability in the underlying parameters is great, so will be the variation in actual emissions . The greater the variation in actual emissions, the greater the potential uncertainty in an emissions estimate that does not account for this variation.

Uncertainty Illustration

Barge Loading

- Loading of:
 - Shallow draft (inland) barge with crude oil.
- AP-42 Section 5.2, Table 5.2-6:
 - Emission factor = 1.0 lb per 1,000 gallons loaded.
 - This is an example of a *fixed-value emission factor*, in that it relates emissions to a single parameter.
- It does not account for variation in:
 - Vapor pressure, temperature, loading method, etc.
 - Yet all of these parameters contribute to emissions.

Definition of the General Loading Loss Equation

- AP-42 Section 5.2, Equation 1:

$$L_L = 12.46 SPM / T$$

where:

L_L = loading loss, pounds per 1,000 gallons loaded.

S = a saturation factor.

P = true vapor pressure of liquid loaded (psia).

M = molecular weight of vapors (lb/lb-mole).

T = temperature of bulk liquid loaded (°R).

Basis for the General Loading Loss Equation

- Accounts for the underlying parameters:
 - Per the Ideal Gas Law (readily derivable).
- Accounts for non-ideal conditions:
 - Per the Saturation Factor (from testing).

Uncertainty in the General Loading Loss Equation

- Two sources of potential uncertainty:
 - Variability in the properties of the liquid being loaded.
 - Variability in the loading conditions.

Example of Variability in Liquid Properties

- True vapor pressure, P , is a function of the Reid Vapor Pressure, RVP .
- Effect of variation in Crude Oil RVP at 60 °F;
 - 10x diff in RVP gives 25x diff in P :

<u>RVP</u>	<u>P</u>
1	0.3
5	2.9
10	7.5

Example of Variability in Conditions

- The Saturation Factor, S , is a function of:
 - The prior condition of the compartment, and
 - The manner in which filling is conducted.
- Effect of variation in loading condition:

<u>Loading Condition</u>	<u>S</u>
Clean tank truck, submerged fill	0.5
Clean tank truck, splash fill	1.45

Effect of Illustrated Variation

$$L_L = 12.46 \text{ SPM} / T$$

For: $P = 0.3, S = 0.5$:

$$L_L = \underline{1.9 \text{ M} / T}$$

For: $P = 7.5, S = 1.45$:

$$L_L = \underline{135.5 \text{ M} / T}$$

Nearly two orders of magnitude range –
for just these two parameters!

Uncertainty in Fixed-Value Emission Factors

- Fixed-value emission factors can have large uncertainties.
 - Actual values may range over a couple of orders of magnitude.
 - The fixed value represented by the emission factor lies at some random point in this range.
- A similar limitation holds true for estimating long-term average emissions from snap-shot-in-time measurements!

Uncertainty in Snap-Shot-in-Time Measurements

- As with a fixed-value emission factor, a snap-shot measurement represents only one point in the range of actual emissions.
- A snap-shot measurement cannot characterize either the average or the limits of the actual range, it is just a random point in the range.

Limitations to Snap-Shot Measurements

- It is not technically defensible to extrapolate a snap-shot measurement beyond the time period within which the measurement was taken.
- It is misleading to characterize the short-term snap-shot measurement as a “measurement” of the long-term annual average emissions.
- There is no statistically defensible basis for correlating a single snap-shot measurement with annual average emissions.

Underreported Emissions?

- Does the foregoing demonstrate that emissions are never underreported?
 - Not at all.
 - It simply demonstrates the statistical fact that extrapolating snap-shot measurements beyond the period of measurement is not valid.
- Under (or over) reporting of emissions is a separate issue which merits serious consideration.

Unaccounted For & Overlooked Emission Sources

- Typically had been deemed either:
 - non-routine, or
 - insignificant.
- Initial focus of regulatory efforts had been on the most routine/significant sources.
- Now that these have been controlled, the non-routine loom larger in relative significance.

Illustration of Change In Significance

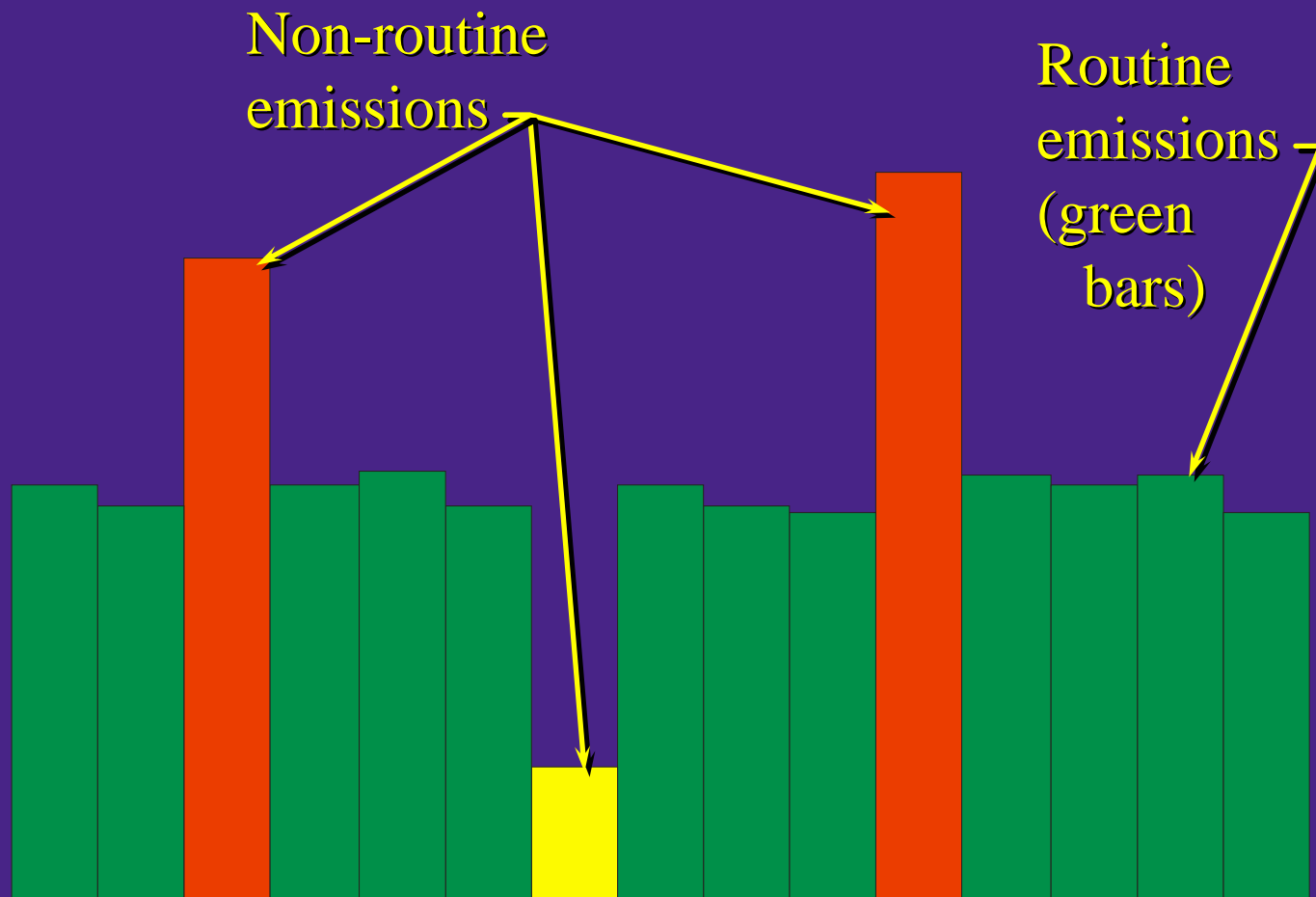
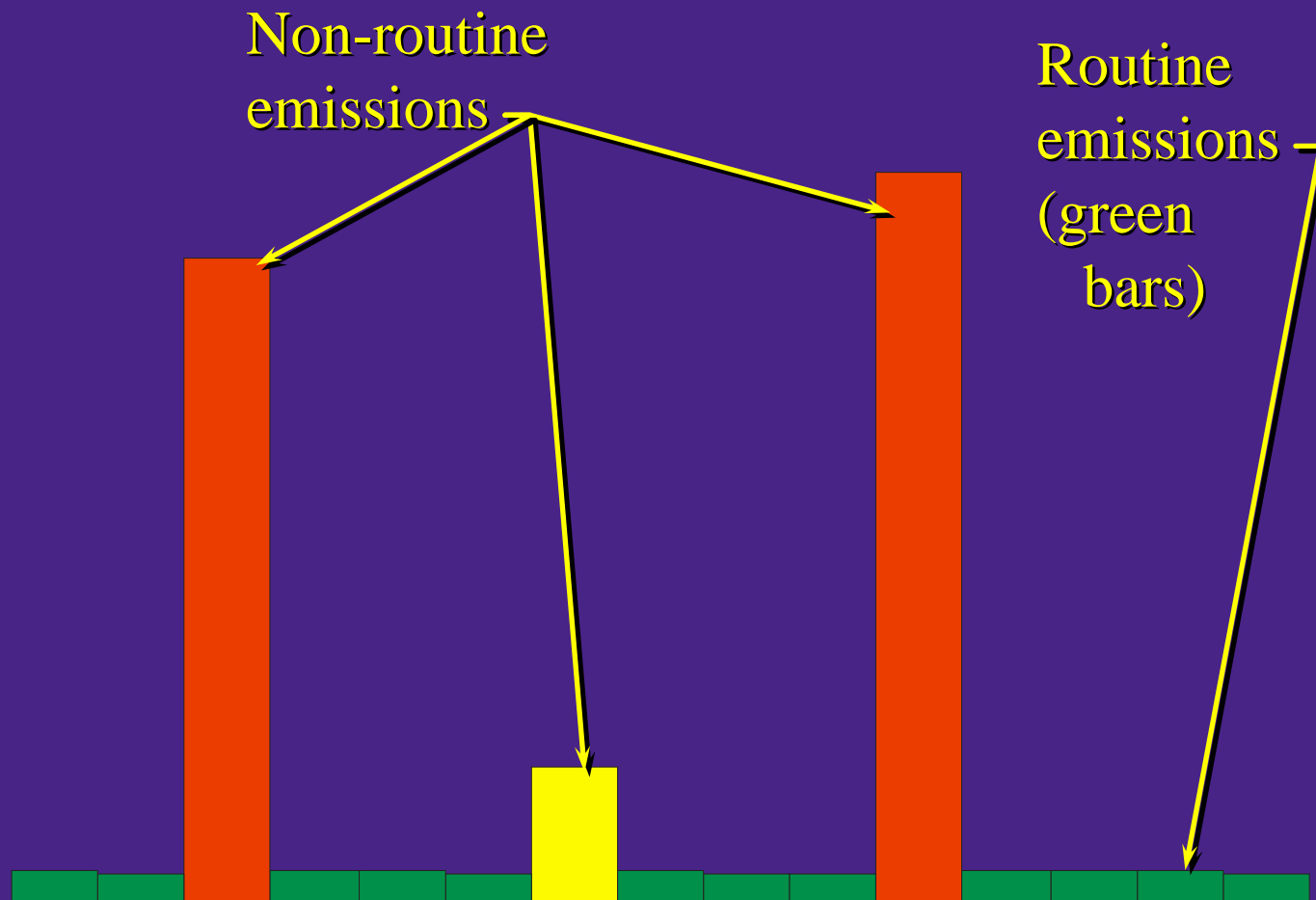

Illustration of Change In Significance



What To Do About Unaccounted-for Sources

- Find them!
- Evaluate them.
- Control as appropriate.
- States with non-attainment areas taking the lead.
 - EPA rules generally focus on routine emissions.
 - If those controls do not achieve attainment, then the State must find the unresolved problems.

Role of Remote Sensing In Identifying Underreported Emissions

- Finding the sources.
 - Unaccounted for operations at known sources
(*e.g.*, floating-roof landing losses).
 - Previously overlooked sources
(*e.g.*, leaking heat exchangers).
 - Poorly maintained sources.
(*e.g.*, failed rim seals on floating roofs).
- IR cameras hold significant promise!

Storage Tank Emission Factors

- Developed from over 20 years of testing.
- Testing and emission factor development have been sponsored by API in cooperation with EPA.
 - Both parties receive and evaluate all data.
- These tests directly measure both:
 - Emission rates, and
 - Values of contributing parameters (*e.g.*, TVP, temp).
- **BECAUSE** – for data to have validity, the variations in parameters must be accounted for!

Current API / EPA Activities

- API & EPA continue to identify & address gaps in the emission factor regime for storage tanks.
 - Floating Roof Landing Losses.
 - Emissions from Tank Cleanings.
 - Liquid Surface Temperature study.

Role of Remote Sensing In Checking Current Emission Factors

- First ask “What is the goal of the test?”
- If it is to find current refinery ‘hot spots’:
 - Then the test would obviously involve a refinery (and the test would be for a limited duration).
- If it is to check storage tank emission factors:
 - Then the test would ideally involve an isolated storage tank (and need to gather a number of representative data points over a longer period).
- The design of the test should be consistent with the goal!

Specific Case of Checking Storage Tank Emission Factors

- Find an isolated tank.
- Measure all pertinent variables throughout the testing period (*e.g.*, TVP, temp).
 - So as to capture diurnal variations.
- Test for a period \gg one day.
 - So as to capture seasonal variations.
- Verify that the emission factors match the tank conditions (*e.g.*, rim seal type & condition).

Role of DIAL In

Checking Current Emission Factors

- Measurement of downwind plume would:
 - Only check overall emissions, but
 - Not emissions from individual tank features.
- Thus useful for:
 - Field-proofing, but
 - Not for adjusting emission factors.
- This was done in the CONCAWE study.
 - In which DIAL measurements showed good agreement with API/EPA emission factors .

Role of IR Cameras In Checking Current Emission Factors

- Current technology does not quantify emissions,
- But it is effective in finding emission points and displaying their relative intensity.
 - Plumes direct attention to specific scenarios.
 - If emission factors would not predict a plume, that scenario may warrant further investigation.
 - For example, HAWK flyovers may have led to investigation of floating-roof landings, if landings had not already been identified as a source.

In Summary

- Emission rates from a given source or operation typically vary over a broad range.
- Fixed-value emission factors have inherent uncertainty, in that they represent only a single random point in that range.
- A similar limitation applies to the use of snapshot measurements to estimate long-term emissions!
- On the other hand, API/EPA storage tank emission factors *account for* variation in the parameters.

Panel Discussions

Introduction

Dan Powell, Chief, Technology
Integration and Information
Branch (TIIB), Office of
Superfund Remediation &
Technology Innovation, EPA

New Technologies to Meet Waste Program Needs

**International Workshop on VOC Fugitive
Losses – New Monitors, Higher Emissions,
and Potential Policy Gaps**

Thursday, October 26, 2006

**Daniel Powell, U.S. EPA
Office of Superfund Remediation and
Technology Innovation**

(703) 603-7196

powell.dan@epa.gov

Office of Solid Waste and Emergency Response – Technology Program

- Advocate for technologies for:
 - Cleanup
 - Characterization
 - Monitoring
 - Data management
- Unique function in media programs
- Formerly Technology Innovation Office
- Now part of Office of Superfund Remediation and Technology Innovation
- Continued focus across waste programs

OSWER Technology Innovation Program (TIP) Role (past and present)

- Create “infrastructure” for technology use, acceptance
 - Policy, guidance
 - Affecting behavior
 - Awareness
 - Supporting information resources
 - Training
 - Beyond technologies
 - Need to understand perspective
 - Methods “guidance” vs. requirements
 - Legal defensibility
 - Reuse orientation

Program Monitoring Needs

- Continued need for new technologies tools
- Remediation performance (long-term, post construction)
- Health and Safety (Fenceline)
- Hot spot ID
- Vapor intrusion
- Reuse driver (fugitive emissions critical aspect; on or near landfills)
- Waste methods guidance vs. regulatory requirements

Program Monitoring Needs

- Dialogue (ongoing):
 - Good public administration
 - Crucial, particularly in tight budget times
- Focus on tools
 - Sampling
 - Analytical
 - Data management
 - New uses for “accepted” tools
- Focus on overall strategies
 - Infrastructure to use tools (Triad)
 - Understanding, communicating and managing all sources of uncertainty

21M²: Measurement and Monitoring Technologies for the 21st Century

- **Established to ensure continued development and application of technologies for evolving EPA waste program needs**
 - Focus on all waste clean-up programs
 - Activities to date
 - Needs analysis (update)
 - “Seed” regional application projects
 - Actual applications
 - Initial site tests
 - Adapt technologies to new conditions
 - \$400K/year annual budget
 - Information resources, dissemination
 - SBIR input

Identified Waste Program Needs-Air-Related

- Air Emissions Monitoring
 - Continuous emissions monitors for use with thermal hazardous waste treatment systems
 - Remote sensing for fence-line monitoring for fugitive emissions/enforcement activities
 - Emergency response
- Indoor Air Quality
 - Monitoring vapor intrusion into buildings
- In-Situ Monitoring Systems

21M2 – Representative Projects

- Open-path monitoring survey of landfill emissions
- Innovative Fence-line Monitor for Metals Emissions
- Dioxin Emission Monitoring Systems (ETV)
- Particulate Matter CEM
- Radon Tracer – Vapor Intrusion

Problem Statement

- Perception: contaminated site cost too much and take too long to cleanup
 - Unexpected findings
 - Regulatory processes
 - Investigation – mobilization after mobilization; never enough data
 - Cleanup – systems do not work as planned
- Unfortunately, that perception has basis in common experiences, often due to:
 - Inadequate understanding of site conditions
 - Insufficient management of all sources of uncertainty
 - Lack of tools sufficient to affordably manage uncertainties

The Triad Approach

Second Generation Practices



Synthesizes practitioner experience, successes, and lessons-learned into an institutional framework

Data Quality: More than Just Analysis

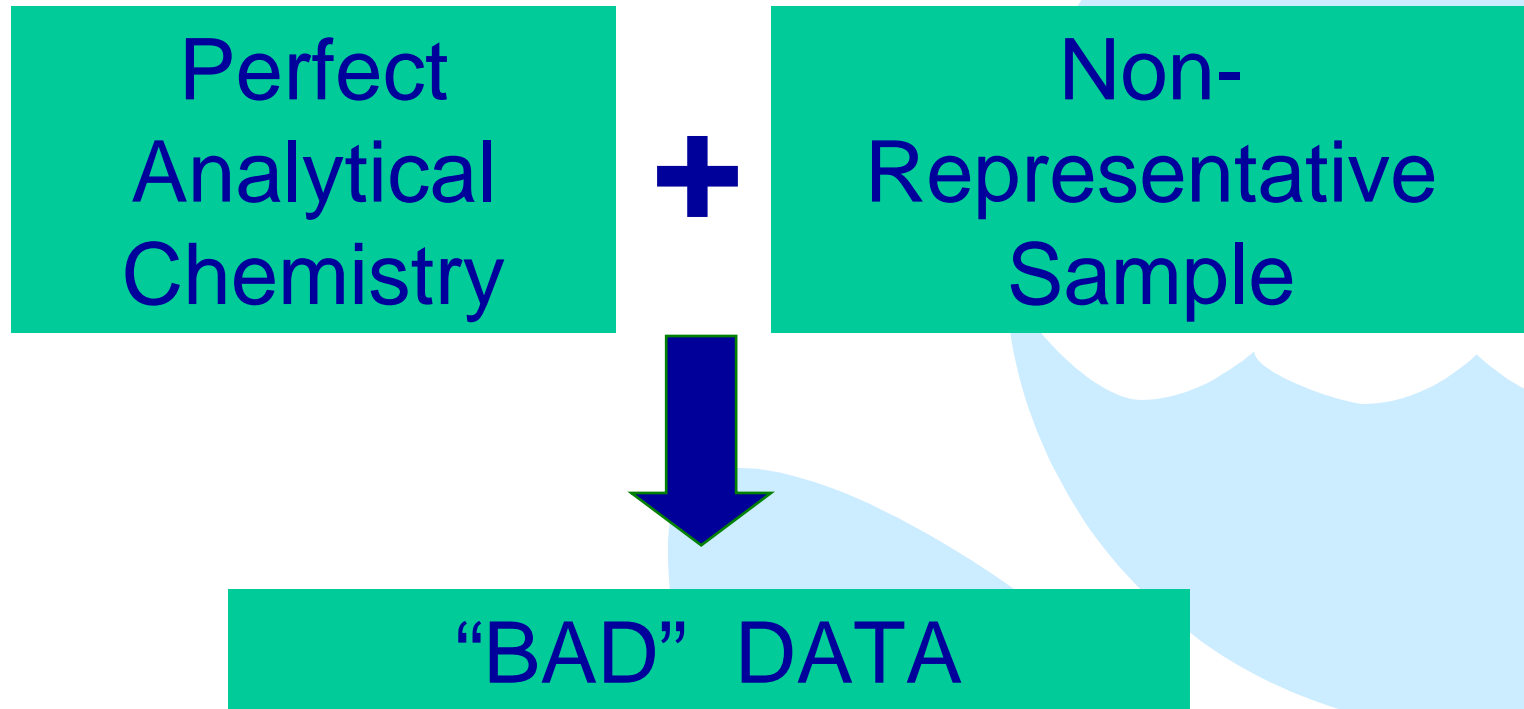

**Distinguish:
Analytical Quality from Data Quality**

Where Do We Go?

- Workshop – 1st Step
- West Coast Version – NERL-LV
- Regular dialogues with project managers, developers, regulators, regulated
- Focus on SBIR, other grant programs
- Identify opportunities – focus on cross-program efficiencies

Where Do We Go?

- Outreach tools – infrastructure is there
 - Web presence
 - Internet seminars
 - Listserv (TechDirect)
 - CLU-IN family (application databases)
 - Case studies
 - Newsletters
- Training
- Policy (must recognize differences)



**And now, on to the
Details**



Appendix D: Outside Resources

This Appendix provides a toolbox of information for learning more about open path technologies. The [overview](#) URL has a basic description of all the open path technologies and a searchable database of over 600 abstracts on various open path subjects. The [case studies](#) section provides a wide range of examples where open path technologies have been deployed and each citation is hyperlinked to its complete article for further information. The [Environmental Technology Verification Program](#) section contains links to EPA performance reports on various open path vendor equipment. The [guidance](#) section has both EPA and European documents on the use of open path equipment. Finally the [vendor](#) section lists the three vendors, with contact information, who were involved in the Canadian and Swedish studies.

OVERVIEW

A layman's description of how DIAL works, some examples of its deployment, and references are found at <http://www.cluin.org/programs/21m2/openpath/lidar/>

CASE STUDIES

An OP-FTIR fence-line monitoring system has been in operation at the TOSCO refinery in Rodeo, California, since 1997. The system consists of two monostatic OP-FTIR configurations deployed along the north and south fence lines of the plant. The one-way optical path of the north fence line is 930 m long and the south path of the south fence line is 955 m. The systems are set to monitor on a frequency of every five minutes and to sound an alarm if concentrations of some 26 target compounds exceed pre-set concentration levels (ppm/m level). Each month a report is developed that evaluates system performance and summarizes the chemicals detected, their concentrations, and the system detection limit for them. The system has a spectral library of over 300 chemicals. Because the collected monitoring spectra are preserved electronically, it is possible to re-examine a given time period to look for the presence of other than target chemicals. See the EPA webpage at <http://www.epa.gov/region09/features/tosco/monitoring.html>, or Contra Costa County Health Services at <http://www.cchealth.org/groups/hazmat/fenceline/>

Bales R., J. Stutz, and S. Hurlock. 2006. Long term measurement of trace gases at GEOSummit using multi-axis differential optical absorption spectroscopy. January 2006. GEOSummit Meeting. <http://www.geosummit.org/resource/06mtg/stutz/>

Bruns, M., S. A. Buehler, J. P. Burrows, K.-P. Heue, U. Platt, I. Pundt, A. Richter, A. Rozanov, T. Wagner and P. Wang. 2004. Retrieval of profile information from airborne multi axis UV/visible skylight absorption measurements. Appl. Opt., 43(22), 4415-4426. http://www.sat.uni-bremen.de/members/sab/publications/doas/doas_retrieval_paper.pdf

Chambers, A. 2003. Well Test Flare Plume Monitoring Phase II: DIAL Testing in Alberta. Alberta Research Council Inc. <http://www.ptac.org/env/dl/envp0402fr.pdf>

Chambers, A. 2004. Optical Measurement Technology for Fugitive Emissions from Upstream Oil and Gas Facilities. Alberta Research Council Inc.
<http://www.ptac.org/env/dl/envp0403.pdf>

Chambers, A. and M. Strosher. 2006. Refinery Demonstration of Optical Technologies for Measurement of Fugitive Emissions and for Leak Detection. Alberta Research Council Inc.
<http://www.arc.ab.ca/ARC-Admin/UploadedDocs/Dial%20Final%20Report%20Nov06.pdf>

Chambers, A., et al. 2006. DIAL measurements of fugitive emissions from natural gas plants and the comparison with emission factor estimates. 15th International Emission Inventory Conference: Reinventing Inventories - New Ideas in New Orleans, 16-18 May 2006, New Orleans, Louisiana.
<http://www.epa.gov/ttn/chief/conference/ei15/session14/chambers.pdf>

EPA. 2002a. Characterization of Mercury Emissions at a Chlor-Alkali Plant, EPA/600/R-02/007. Office of Research and Development.
<http://www.epa.gov/nrmrl/pubs/600r02007/600R02007.pdf>

EPA. 2002b. Superfund Five-Year Review Report: Brantley Landfill NPL Site Island, Kentucky. EPA Region IV, 136 pp. <http://www.epa.gov/superfund/sites/fiveyear/f02-04016.pdf>

EPA. 2004. Measurement of Fugitive Emissions at a Region I Landfill, EPA-600/R-04-001. <http://www.cluin.org/programs/21m2/projects/epa600r04001.pdf>

EPA. 2005a. Evaluation of a Former Landfill Site in Fort Collins, Colorado Using Ground-Based Optical Remote Sensing Technology, EPA-600/R-05/042.
http://www.cluin.org/programs/21m2/spotlight/Ft_Collins_Report.pdf

EPA. 2005b. Evaluation of Fugitive Emissions at a Former Landfill Site in Colorado Springs, Colorado Using Ground-Based Optical Remote Sensing Technology, EPA-600/R-05/041. http://www.clu-in.org/programs/21m2/spotlight/Colorado_Springs_Report.pdf

EPA Victoria. 2005. Benzene Air Monitoring in Corio 2003–2005. Environmental Report Publication 999. 8 pp.
[http://epanote2.epa.vic.gov.au/EPA/publications.nsf/d85500a0d7f5f07b4a2565d1002268f3/cedcb7ec217f5842ca256ffe00818bab/\\$FILE/999.pdf](http://epanote2.epa.vic.gov.au/EPA/publications.nsf/d85500a0d7f5f07b4a2565d1002268f3/cedcb7ec217f5842ca256ffe00818bab/$FILE/999.pdf)

Friedeburg, C., I. Pundt, K.-U. Mettendorf, T. Wagner, and U. Platt. 2005. Multi-axis-DOAS measurements of NO₂ during the BAB II motorway emission campaign. Atmospheric Environment 39 (2005) pp 977–985. <http://www.imk.uni-karlsruhe.de/download/BAB-Friedeburg.pdf>

Frisch, L. 2003. Fugitive VOC-Emissions Measured at Oil Refineries in the Province of Västra Götaland in South West Sweden - A Success Story Development and Results 1986–2001. County Administration of Västra Götaland, Report No. 2003:56.
http://www.clu-in.org/programs/21m2/projects/rapport200356-Final_VOC.pdf

Frish, M. 2006. Low-cost standoff laser sensing for smart LDAR. AWMA 99th Annual Conference, June 20-23, 2006, New Orleans, Louisiana.
<http://www.psicorp.com/publications/PDF/sr-1239.pdf>

Fuji , S., J. Liu, P. Xie, and Y. Zhang. 2006. Correlation study between suspended particulate matter and DOAS data. *Advances in Atmospheric Sciences*, Vol. 23, No. 3, pp 461–467. <http://www.iap.ac.cn/html/qikan/aas/aas2006/200603/233sfq.pdf>

Goorahoo, D., et al. 2005. Measuring ammonia emissions from agricultural practices. *Conference Proceedings 2005 California Plant and Soil Conference Science & Policy in California Agriculture*, pp 46-49.
http://calasa.ucdavis.edu/proceedings/2005_Proceedings.pdf

Goorahoo, D., et al. 2004. Use of laser technology to monitor ammonia emissions from dairy lagoons. *Conference Proceedings 2004 California Plant and Soil Conference Science & Policy in California Agriculture*.
<http://www.epa.gov/ttn/chief/conference/ei14/session1/goorahoo.pdf>

Grenn, B., et al. 2005. Extending optical methane leak detection to mobile platforms. *Natural Gas Technologies 2005*, January 30-February 2, 2005, Orlando, Florida.
<http://www.psicorp.com/publications/PDF/sr-1203.pdf>

Halla, J., D. Majonis, and R. McLaren. 2006. Trace gas measurements using MAX-DOAS in a polluted marine environment. *Third International DOAS Workshop*, University of Bremen, March 20-26, 2006. http://troposat.iup.uni-heidelberg.de/AT2/DOAS_workshop/doas_ws_2006_program.html

Heckel, A., A. Richter, T. Tarsu, F. Wittrock, C. Hak, I. Pundt, W. Junkermann, and J. P. Burrows. 2005. MAX-DOAS measurements of formaldehyde in the Po-Valley. *Atmos. Chem. Phys.*, 5, 909–918. <http://www.copernicus.org/EGU/acp/acp/5/909/acp-5-909.pdf>

Ibrahim, O., T. Stein, T. Wagner, and U. Platt. 2006. Auto-MAX DOAS: A new measurement platform. *Third International DOAS Workshop*, University of Bremen, March 20-26, 2006. http://troposat.iup.uni-heidelberg.de/AT2/DOAS_workshop/doas_ws_2006_program.html

Jiménez, R., T. Iannone, H. van den Bergh, B. Calpini, and D. Kita. 2000. Investigation of the emission of monocyclic aromatic hydrocarbons from a wastewater treatment plant at Lausanne (Switzerland) by differential optical absorption spectroscopy (DOAS). *Proceedings of A&WMA 93rd Annual Conference & Exhibition*, 18-22 June 2000, Salt Lake City, Utah. Paper #830, 17 pp, 2000.
http://www.cluin.org/programs/21m2/lit_show.cfm?id=886

Lenz, D. et al. 2005. Flight Testing of an Advanced Airborne Natural Gas Leak Detection System. U.S. Department of Energy, 84 pp. http://www.netl.doe.gov/technologies/oil-gas/publications/td/41877_final.PDF

Kihlman, M., J. Mellqvist, and J. Samuelsson. 2005. Monitoring of VOC Emissions from Refineries and Storage Depots Using the Solar Occultation Flux Method, 102 pp. <http://www.fluxsense.se/reports/SOF%20Refinery%20report-%20KORUS%20%202005%20%20high%20res.pdf>

Kim, K.-H. 2004. Comparison of BTX measurements using a differential optical absorption spectroscopy and an on-line gas chromatography system. Environmental Engineering Science, Mar 2004, Vol. 21, No. 2: pp 181-194. <http://www.liebertonline.com/doi/abs/10.1089/109287504773087354;jsessionid=ildHkoAhbAM45fWgNY?cookieSet=1&journalCode=ees>

Laepfle, T., V. Knab, K.-U. Mettendorf, and I. Pundt. 2004. Longpath DOAS tomography on a motorway exhaust gas plume: Numerical studies and application to data from the BAB II campaign. <http://www.atmos-chem-phys.net/4/1323/2004/acp-4-1323-2004.pdf>

Mellqvist J., M. Kihlman, B. Galle, K. Fransson, and J. Samuelsson. Undated. The Solar Occultation Flux Method, A Nouvelle Technique for Quantifying Fugitive Gas Emissions. <http://www.fluxsense.se/reports/paper%201%20final%20lic.pdf>

Mellqvist, J. et al. 2006. The solar occultation flux method, a new technique to quantify fugitive VOC emissions. Proceedings of CEM 2006. 7th International Conference on Emission Monitoring, Paris, Feb 2006, 9 pp. <http://www.fluxsense.se/reports/THE%20SOF%20METHOD%20extended%20abstract%20CEM%202006.pdf>

Mettendorf, K., C. Kunz, V. Knab, H. Sun, and I. Pundt. 2003. The multibeam DOAS long path DOAS system; a new apparatus for simultaneous measurements along different light paths. Geophysical Research Abstracts, Vol. 5, 12055. <http://www.cosis.net/abstracts/EAE03/12055/EAE03-J-12055.pdf?PHPSESSID=b41ac16d57f9bc737075b71b915972f3>

Mettendorf, K., A. Hartl, U. Platt, and I. Pundt. 2005. Long path DOAS tomography by the use of multibeam DOAS instruments: Results of an indoor validation campaign. Geophysical Research Abstracts, Vol. 7, 08543. <http://www.cosis.net/abstracts/EGU05/08543/EGU05-J-08543.pdf>

Mount, G., B. Rumburg, J. Havig, B. Lamb, H. Westberg, D. Yonge, K. Johnson, and R. Kincaid. 2002. Measurement of atmospheric ammonia at a dairy using differential optical absorption spectroscopy in the mid-ultraviolet. Atmospheric Environment, 2002, 36(11), pp 1799-1810. http://www.dicer.org/jsp/journal/show_article.jsp?jid=JA-4-36-11-1799

Pisano, J. et al. 2003. A UV differential optical absorption spectrometer for the measurement of sulfur dioxide emissions from vehicles. Meas. Sci. Technol. 14, pp 2089-2095. <http://www.iop.org/EJ/abstract/0957-0233/14/12/007>

Poehler, D., A. Hartl, and U. Platt. 2006. Tomographic DOAS measurements of 2D trace gas distributions above the city centre of Heidelberg, Germany. Third International DOAS Workshop, University of Bremen, March 20-26, 2006. http://troposat.iup.uni-heidelberg.de/AT2/DOAS_workshop/doas_ws_2006_program.html

Pundt, I. and K.-U. Mettendorf. 2005. Multibeam long-path differential optical absorption spectroscopy instrument: a device for simultaneous measurements along multiple light paths. Appl. Opt. 44, pp 4985-4994. <http://www.opticsinfobase.org/abstract.cfm?URI=ao-44-23-4985>

Schaefer, K., H. Hoffmann, I. Dormuth, C. Jahn, and S. M. Emeis. 2002. VOC emission source strengths of tankers during refueling activities determined by spectroscopic remote sensing and inverse dispersion modeling. Remote Sensing of Clouds and the Atmosphere VI. Proceedings of SPIE - The International Society for Optical Engineering, Vol 4539, p 247-257, 2002. http://www.cluin.org/programs/21m2/lit_show.cfm?id=1608

Schäfer, K., et al. 2006. Determination of NO and NO₂ aircraft emission indices at airports by open-path DOAS. Third International DOAS Workshop, University of Bremen, March 20-26, 2006. http://troposat.iup.uni-heidelberg.de/AT2/DOAS_workshop/doas_ws_2006_program.html

Schlosser, E., J. Bossmeyer, T. Brauers, H.-P. Dorn, and R. Tillmann. 2006. HCHO detection by high-resolution laser DOAS. Third International DOAS Workshop, University of Bremen, March 20-26, 2006. http://troposat.iup.uni-heidelberg.de/AT2/DOAS_workshop/doas_ws_2006_program.html

Secrest, C. 2001. Field measurement of air pollutants near swine confined-animal feeding operations using UV DOAS and FTIR. Water, Ground, and Air Pollution Monitoring and Remediation, 6-7 November 2000. Proceedings of SPIE–The International Society for Optical Engineering, Vol 4199, p 98-104, 2001. http://www.cluin.org/programs/21m2/lit_show.cfm?id=868

Smithers, B. et al. 1995. VOC Emissions From External Floating Roof Tanks: Comparison of Remote Measurements by Laser With Calculation Methods. CONCAWE, Report No. 95/52, 74 pp. Go to page 12 of <http://www.concawe.org/Content/Default.asp?PageID=31>

Spectrasyne, Ltd. 1999. A VOC Emissions Survey at the SCANRAFF Refinery, Lysekil. Aug/Sep 1999, 59 pp.

Varma, R., R. Hashmonay, R. Kagaan, and A. Bolch. 2005. Optical Remote Sensing to Determine Strength of Nonpoint Sources: Duke Forest Control Experiments (ESTCP # CP-0214) . Report No: AFRL-ML-TY-TR-2005-4584, 97 pp. <http://stinet.dtic.mil/cgi-bin/GetTRDoc?AD=ADA440825&Location=U2&doc=GetTRDoc.pdf>

Webb, J., R. Spellicy, and R. Brewer. 2006. Using FTIR spectrometry for industrial and environmental gas analysis. EM-Pittsburgh, Air and Waste Management Association. <http://www.awma.org/onlinelibrary/ProductDetails.aspx?productID=2074>

Wittrock, F., A. Heckel, H. Oetjen, A. Richter, and J. Burrows. 2006. The retrieval of oxygenated volatile organic compounds by remote sensing techniques. Third International DOAS Workshop, University of Bremen, March 20-26, 2006. http://troposat.iup.uni-heidelberg.de/AT2/DOAS_workshop/doas_ws_2006_program.html

Zhang, K. and H. C. Frey. 2006. Road grade estimation for on-road vehicle emissions modeling using light detection and ranging data. Journal of Air and Waste Management Association, June 2006. <http://www.awma.org/onlinelibrary/ProductDetails.aspx?productID=6434>

ENVIRONMENTAL TECHNOLOGY VERIFICATION PROGRAM

The EPA ETV program has tested three OP-FTIR instruments, and the verification reports are available on the ETV website at: <http://www.epa.gov/etv>

Ail Sytems Inc. - RAM 2000 Fourier Transform Infrared Open-Path Monitor
Verification Statement (PDF, 42.2 K) http://www.epa.gov/etv/pdfs/vrvs/01_vs_ail.pdf
Verification Report (PDF, 541K) http://www.epa.gov/etv/pdfs/vrvs/01_vr_ail.pdf

Bruker Daltonics, Inc. OPAG 22 Open-Path Gas Analyzer
Verification Report. http://www.epa.gov/etv/pdfs/vrvs/01_vr_bruker_opag.pdf

Spectrex, Inc. - SafEye 227 Infrared Open-Path Monitor
Verification Statement: http://www.epa.gov/etv/pdfs/vrvs/01_vs_safeyetwo.pdf
Verification Report: http://www.epa.gov/etv/pdfs/vrvs/01_vr_safeyetwo.pdf

The EPA ETV program has tested two TDL instruments.

OP SIS AB LD500 Continuous Emission Monitor for Ammonia
Verification Statement http://www.epa.gov/etv/pdfs/vrvs/01_vs_opsis_ld500.pdf
Verification Report http://www.epa.gov/etv/pdfs/vrvs/01_vr_opsis_ld500.pdf

Siemens Laser Analytics AB LDS 3000 Continuous Emission Monitor for Ammonia
Verification Statement http://www.epa.gov/etv/pdfs/vrvs/01_vs_siemens.pdf
Verification Report http://www.epa.gov/etv/pdfs/vrvs/01_vr_siemens.pdf

GUIDANCE AND REPORTS

EPA. 1996. Open Path FI-TR Monitoring Guidance Document, EPA 600/R96/040. Office of Research and Development, National Exposure research Laboratory, 176 pp. <http://www.epa.gov/ttnamti1/files/ambient/other/Inpath/r-96-040.pdf>

EPA. 2004. EPA's Method for Calculating Air Toxics Emissions for Reporting Results Needs Improvement, Report No. 2004-P-00012. Office of the Inspector General, 41 pp. <http://www.epa.gov/oig/reports/2004/20040331-2004-p-00012.pdf>

EPA. 2006. Other Test Method 10 (OTM 10)—Optical Remote Sensing for Emission Characterization from Non-Point Sources. <http://www.epa.gov/ttn/emc/prelim/otm10.pdf>

Sira, Ltd. 2004a. Recommendations for Best Practise in the Use of Open-Path Instrumentation : A Review of Best Practise Based on the Project "Remote Optical Sensing Evaluation" (ROSE) August 2001-July 2004. ROSE Consortium.

Sira Ltd. 2004b. Recommendations for Performance Standards for Open-Path Instrumentation. Remote Optical Sensing Evaluation (ROSE) Consortium, 174 pp.

VENDORS

The DIAL LIDAR system used for the Canadian studies was provided by Spectrasyne, Ltd. For more information on Spectrasyne see:
http://www.spectrasyne.ltd.uk/html/about_dial.html

The RPM technology is provided by ARCADIS:
<http://www.arcadis-us.com/>

The company that performed the infrared camera survey in the Canadian studies was Leak Surveys, Inc. For more information on Leak Surveys see:
<http://www.leaksurveysinc.com/>

Fluxsense, AB is a spin off company from research done at Chalmers University of Technology in Göteborg, Sweden. They have a number of reports and papers on the Solar Occultation Flux Method. http://www.fluxsense.se/sof_reference_reports.htm