

## EVALUATION OF ALTERNATIVE INTAKE TECHNOLOGIES AT INDIAN POINT UNITS 2 & 3



Prepared for Entergy Nuclear Indian Point 2, LLC, and Entergy  
Nuclear Indian Point 3, LLC

Prepared by:



Enercon Services, Inc.  
500 TownPark Lane, Suite 275  
Kennesaw, GA 30144

February 12, 2010

TABLE OF CONTENTS

Attachments .....	iii
Executive Summary .....	iv
1 Background and Introduction .....	1
1.1 Purpose of this Evaluation.....	1
1.2 Scope and Design Objectives.....	1
2 IPEC Stations and Cooling Systems Description .....	2
2.1 IPEC Units 2 and 3 Overview .....	2
2.2 Description of Plant Processes .....	2
2.2.1 Nuclear Steam Supply System Operations .....	2
2.2.2 Condenser Operation .....	3
2.2.3 Effluent Treatment Operation .....	4
2.3 Source Waterbody .....	5
2.3.1 Source Waterbody Description .....	5
2.3.2 Hydraulic Zone of Influence .....	6
2.3.3 Intake Volume Calculation .....	6
2.4 CWIS Description .....	7
2.4.1 Physical Description, Location and Depth of CWIS .....	7
2.4.1.1 Current Traveling Water (Ristroph) Screens.....	9
2.4.1.2 Fish Handling and Return System .....	11
2.4.2 CWIS Flow Description.....	13
2.4.2.1 Pump Descriptions.....	13
2.4.2.2 Design Intake Capacity.....	16
2.4.2.3 Flow Reductions from Baseline .....	17
2.4.2.4 Through-Screen Velocity .....	19
2.4.2.5 Seasonal Changes in CWIS Operation .....	21
2.4.3 Biocide Treatment.....	21
2.5 Discharge System.....	21
2.6 Cooling System Equipment.....	23
2.7 License Status.....	24
3 Existing CWIS Technologies and Operational Measures that Affect I&E.....	25
3.1 Description of Existing CWIS Technologies and Current Operational Measures that Affect I&E .....	25
3.1.1 Existing Traveling Water Screens .....	25
3.1.2 Existing Fish Handling and Return System .....	26
3.1.3 Flow Reductions .....	27
3.1.3.1 Dual/Variable Speed Pumps.....	27
3.1.3.2 Historic Flow Reductions .....	27
3.1.3.3 Outage Schedule .....	29
3.2 Percent Reductions in I&E from Baseline for Existing CWIS Technologies and Current Operational Measures .....	29
4 I&E Reduction Technologies.....	30
4.1 Upgrade of the Existing Fish Handling and Return Systems.....	30
4.2 Traveling Water Screens .....	31

4.2.1	Alternative Ristroph Screens .....	32
4.2.2	Dual Flow Traveling Water Screens.....	35
4.2.3	Angled Traveling Screens.....	39
4.2.4	WIP Screens.....	43
4.2.5	MultiDisc® Screens.....	48
4.3	Passive Intake Systems.....	51
4.3.1	Cylindrical Wedgewire Screens.....	51
4.3.2	Perforated Pipe Inlets.....	63
4.3.3	Porous Dikes/Leaky Dams.....	65
4.4	Barrier Technologies.....	68
4.4.1	Aquatic Filter Barriers .....	68
4.4.2	Fish Barrier Nets.....	76
4.4.3	Behavioral Barriers .....	79
4.4.3.1	Light Guidance System .....	80
4.4.3.2	Acoustic Deterrents .....	81
4.4.3.3	Air Bubble Curtains.....	82
4.4.3.4	Electrical Barriers.....	84
4.4.4	Louver System .....	86
4.5	Alternate Intake Location.....	88
4.6	Flow Reduction .....	90
4.6.1	Dual/Variable Speed Pumps .....	91
4.6.1.1	Flow Reduction Parameters/Methodology .....	91
4.6.1.2	Flow Reduction Impacts.....	93
4.6.1.3	Effects of Further Operational Flow Reductions.....	97
4.6.1.4	Conversion of Unit 2 to Variable Speed Pumps.....	98
4.6.2	Use of Recycled Wastewater as Cooling Water .....	99
4.6.3	Outage Timing .....	101
4.6.4	Radial Wells.....	102
4.7	Alternative Heat Rejection and Recirculation.....	105
4.7.1	Evaporative Ponds .....	105
4.7.2	Spray Ponds .....	107
4.7.3	Cooling Canals.....	108
4.7.4	In-River Heat Exchangers.....	110
5	Conclusions.....	113
6	References.....	119

**Attachments**

Attachment 1 – Major Components; Vendor Data and References

Attachment 2 – Post-Modification Site Renderings and Conceptual Drawings

Attachment 3 – Evaluation of VSP Performance

Attachment 4 – Capital Costs Assessments

Attachment 5 – Figures

Attachment 6 – Biological Assessment

Attachment 7 – Recycled Wastewater Cooling

### Executive Summary

Entergy Nuclear Indian Point 2, LLC, and Entergy Nuclear Indian Point 3, LLC (collectively, Entergy) have submitted a timely and complete renewal application for a State Pollutant Discharge Elimination System (SPDES) permit (SPDES Permit NY0004472) for Indian Point Energy Center (IPEC) nuclear powered electric generation stations 2 and 3 (individually, Unit 2 and Unit 3, respectively, and collectively, the Stations). The New York State Department of Environmental Conservation staff (NYSDEC) has proposed modifications in the Stations' draft SPDES permit, including possible construction and operation of cooling towers in a closed-loop cooling configuration (NYSDEC Proposed Project). Consideration of closed-loop cooling is subject to certain feasibility and alternative technologies assessments, as directed by the NYSDEC Assistant Commissioner's August 13, 2008 Interim Decision (Interim Decision). Accordingly, the NYSDEC may revisit its proposed modifications to the draft SPDES permit for the Stations and change them pursuant to Entergy's feasibility and alternative technologies assessments.<sup>1</sup>

As part of the alternative technologies assessment, Entergy retained Enercon Services, Inc. (ENERCON) to determine whether an alternative technology exists that "will minimize adverse environmental impact to a level equivalent to that which can be achieved by closed-loop cooling" (see the Interim Decision). In order to obtain reliable aquatic information associated with the existing intake technologies at each Unit, closed-loop cooling, and each alternative technology evaluated, ENERCON relied on aquatic and biological information, including comprehensive entrainment and impingement data, from biological experts Lawrence W. Barnhouse of LWB Environmental Services, Inc., Douglas G. Heimbuch of AKRF, Inc., Mark T. Mattson of Normandeau Associates, Inc., and John R. Young of ASA Analysis & Communication, Inc. (collectively, the Biological Experts).

This Report identifies and evaluates potential alternative technologies to closed-loop cooling, focusing on: (1) technological or engineering feasibility; (2) comparative effectiveness in terms of impingement and entrainment losses (I&E) (based on an evaluation prepared by the Biological Experts, Attachment 6); and (3) estimated cost, based on a detailed, site-specific conceptual design.

Cylindrical wedgewire screens (CWW) are technologically feasible at the Stations. This technology also shows great promise in reducing I&E, based on extensive technical work performed by Alden Laboratories in 2003, 2004 and 2005, as analyzed by the Biological Experts. In addition, CWW screens have been implemented at a facility with a total intake flow rate comparable to the total intake flow rate at the Stations. Specifically, Oak Creek Power Plant in Milwaukee, Wisconsin operates the current largest installation of cylindrical wedgewire screens, which includes an offshore intake system that filters a flow rate of 1,560,000 gallons per minute (gpm) at a through-screen velocity of 0.5 feet per second (fps) with a 16% margin. The CWW system at Oak Creek became operational in January 2009 and is designed to operate year round. This new information provided ENERCON with recent valuable data to evaluate CWW at the IPEC Stations.

---

<sup>1</sup>The Interim Decision provides that NYSDEC must evaluate Entergy's alternative technology assessment and commence a proceeding to modify the draft SPDES permit if it determines that the proposed alternative technology may be substituted for the NYSDEC Proposed Project (i.e., closed-loop cooling).

Several conceptual CWW screening array designs, each fitting within the Stations' exclusionary zone, were created. Although the United States Environmental Protection Agency (EPA) typically recommends cylindrical wedgewire through-slot velocities at or below 0.5 feet per second (fps), NYSDEC has indicated interest in through-slot velocities at or below 0.25 fps. As such, separate conceptual cylindrical wedgewire screen systems were designed to provide a maximum through-slot velocity of at or below both 0.5 fps and 0.25 fps.

Cylindrical wedgewire screens are expected to achieve biological benefits (i.e., reductions in I&E) comparable to those that could be achieved by the NYSDEC Proposed Project. Specifically, operation of cylindrical wedgewire screens with a mesh size of 2.0 mm and through-slot velocity at or below 0.5 fps has the potential to reduce equivalent age 1 (EA1)<sup>2</sup> impingement and entrainment losses from the regulatory baseline<sup>3</sup> by as much as approximately 99.9% and 89.8%, respectively. In addition, the Biological Experts provided an evaluation of the cumulative reductions in I&E over the expected lifetimes of Unit 2 and Unit 3 associated with cylindrical wedgewire screens, as compared to closed-loop cooling. This analysis accounted for a current proposal based on cylindrical wedgewire screen studies to install this technology at Unit 2 by 2013 and Unit 3 by 2015.<sup>4</sup> Closed-loop cooling, by contrast, would not be complete until 2029 based on a schedule derived by ENERCON, with input from counsel and Spectra Energy Transmission, LLC (owner of the Algonquin Gas Transmission Pipeline, which would require relocation in order to construct a closed-loop cooling tower at Unit 3).<sup>5</sup> Based on this evaluation, the estimated cumulative total reduction in EA1 I&E for cylindrical wedgewire screens (98% and 87% for EA1 impingement and entrainment losses, respectively) would be greater than the estimated cumulative total reduction in EA1 I&E for closed-loop cooling (86% and 50% for EA1 impingement and entrainment losses, respectively).

Nonetheless, while promising, before a specific CWW array can be located and operated at the Stations, site-specific analyses would be required to determine the optimal location and slot width for reducing entrainment, with particular focus on the slot width at which fouling (i.e., the accumulation of matter on the screens) would not be a concern to Station operations.

Other alternative technologies were evaluated, but were not recommended due to site-specific issues. As detailed in this Report, for instance, due to nuclear-safety issues, the use of aquatic filter barriers or other technologies that could potentially block the service water intake at each Unit (e.g., fish barrier nets, porous dikes) are not considered as primary alternatives. Several technologies (e.g., spray ponds, evaporative ponds, cooling canals, radial wells) were identified as infeasible due to lack of available land area. The use of coarse or fine mesh traveling water screens of a different mesh size than currently employed at the Stations would not be expected to

---

<sup>2</sup> As noted in Attachment 6, natural mortality of early life stages of fish (i.e., eggs and larvae) is very high. Conversion to equivalent age-1 fish allows I&E that occur at different life stages to be combined into a single metric that weights the losses according to the number that could, on average, have survived to age 1.

<sup>3</sup> As noted in Attachment 6, the regulatory baseline is a regulatory construct that employs certain operation and survival assumptions. This baseline has been used by NYSDEC in SPDES permit proceedings for other New York power plants.

<sup>4</sup> ENERCON has reviewed the proposed schedule described in the biological cumulative analysis (Attachment 6); a detailed schedule for implementation of cylindrical wedgewire screens at the Stations would be created during the detailed design phase.

<sup>5</sup> Engineering Feasibility and Costs of Conversion of Indian Point Units 2 and 3 to a Closed-Loop Condenser Cooling Water Configuration, Enercon Services, Inc., 2010

significantly reduce I&E beyond the existing screening systems. Several technologies (e.g., behavioral barriers) have been studied previously and identified as ineffective at the Stations and would require further evaluation to determine their site-specific technological feasibility.

Upgrades to the existing fish return systems were not recommended because the Stations' existing traveling water screens and fish return systems are considered state-of-the-art for impingement reduction.

# **1 Background and Introduction**

Entergy retained ENERCON to work in conjunction with the Biological Experts to determine whether an alternative intake technology exists that will achieve reductions in I&E comparable to that of the NYSDEC Proposed Project. In order to obtain I&E information associated with the existing intake technologies at each Unit, the NYSDEC Proposed Project, and each alternative technology evaluated, ENERCON relied on aquatic and biological information, including comprehensive entrainment and impingement data, provided by the Biological Experts. This evaluation is pursuant to the Interim Decision, which provides that if Entergy proposes an alternative technology that reduces I&E to a level comparable to the NYSDEC Proposed Project, NYSDEC must commence a proceeding to modify the draft SPDES permit.

## **1.1 Purpose of this Evaluation**

This Report evaluates the technological feasibility, comparative I&E reductions, and estimated costs of several alternative technologies. The Stations' existing technologies and operational measures are also evaluated to provide a comparative basis for assessing alternative technologies.

## **1.2 Scope and Design Objectives**

This Report provides the following:

- In Sections 2 and 3, a detailed description of the operation and features of the existing cooling water intake structures (CWISs) at the Stations, intake flow characteristics, and recent, planned maintenance of the CWISs. These Sections also include an evaluation of the existing technologies and operational measures implemented at the Stations to reduce I&E.
- In Section 4, an evaluation of several alternative technologies.
- In Section 5, relevant conclusions.



## 2 IPEC Stations and Cooling Systems Description

### 2.1 IPEC Units 2 and 3 Overview

Entergy owns and operates Unit 2 and Unit 3, both located in Buchanan, New York on the east bank of the Hudson River. The primary activity of each Unit is the generation of electric power. Entergy Nuclear Indian Point 2, LLC also owns IPEC Unit 1, but it was removed from service in October 1974. Thus, this Report focuses on Units 2 and 3.

Unit 2 and Unit 3 are Westinghouse Pressurized Water Reactors (PWRs) that produce steam for direct use in steam turbines in order to generate electricity. Unit 2 began commercial operation in August 1974 and currently generates electricity at a rated capacity of approximately 1078 MWe [Ref. 6.60]. Unit 3 began commercial operation in August 1976 and currently generates electricity at a rated capacity of approximately 1080 MWe [Ref. 6.64]. The CWISs provide cooling water to absorb waste heat rejected by the Stations. According to 40 CFR §125.93, a CWIS is defined as “the total physical structure and any associated constructed waterways used to withdraw cooling water from waters of the U.S. The cooling water intake structure extends from the point at which water is withdrawn from the surface water source up to, and including, the intake pumps.” Unit 2 and Unit 3 were designed, constructed, and licensed, and are operated, to withdraw cooling water from the Hudson River via two shoreline once-through CWISs. According to 40 CFR Part 125, §125.93, cooling water is defined as “...water used for contact or non-contact cooling, including water used for equipment cooling, evaporative cooling tower makeup, and dilution of effluent heat content.”

### 2.2 Description of Plant Processes

#### 2.2.1 Nuclear Steam Supply System Operations

PWRs are designed to produce electrical energy. Thermal energy is produced by the reactor and transferred to steam. The thermal energy in the steam is converted (via a turbine driven generator) to electrical energy. At Unit 2 and Unit 3, the exhaust steam is converted into water after leaving the turbine and returned to the steam generators as heated feedwater with dissolved and suspended solids removed. There are two major systems used by a PWR to convert the thermal energy of the fuel into electrical energy. The primary system transfers heat from the primary water to the steam generator, while the secondary system transfers the steam formed in the steam generator to the turbine generator. The expanded steam exhausted by the turbine generator is condensed into water by the flow of circulating water through the condenser tubes [Ref. 6.120].

The primary system is also called the Reactor Coolant System (RCS) and consists of four similar heat transfer loops connected in parallel to the reactor vessel. Each loop contains a reactor coolant circulation pump and a steam generator. The RCS also includes a pressurizer, a pressurizer relief tank, the associated piping, and the instrumentation necessary for operational control. The RCS transfers the thermal energy generated in the core to the steam generators where steam is generated to drive the turbine generator. The RCS also provides a boundary for containing the reactor coolant under operating

temperature and pressure conditions, and confines radiological materials. Demineralized water in the reactor coolant loops is maintained under high pressure to prevent the water from boiling. The pressurizer uses electrical heaters and water sprays to maintain water pressure in the reactor coolant loops [Ref. 6.64].

The secondary system is often called the Steam and Power Conversion System (SPCS). The SPCS is designed to remove heat from the reactor coolant in the steam generators, produce steam for use in the turbine-generators, condense the turbine exhaust steam into water, and return the condensed water to the steam generators as feedwater. The major components of this system include the tube side of the steam generators, the turbine-generator, condensers, feedwater pumps, the associated piping, and the instrumentation necessary for operational controls. Feedwater enters the steam generators where it is converted into a steam-water mixture. After a steam swirl vane assembly separates the steam from the water particles, the steam rises through additional separators, which further reduce its moisture content. The saturated steam is then passed through the turbine-generators. Each Unit has a tandem compound turbine comprised of one high pressure turbine and three low pressure turbines that rotate at 1800 rpm. The saturated steam is first passed through the high pressure turbine then through the low pressure turbines. From the low pressure turbines, the steam is exhausted into the condensers where it is condensed and de-aerated, and then returned to the cycle as feedwater to the steam generators [Ref 6.120].

A simplified schematic of a typical PWR plant is shown in Figure 2.1.

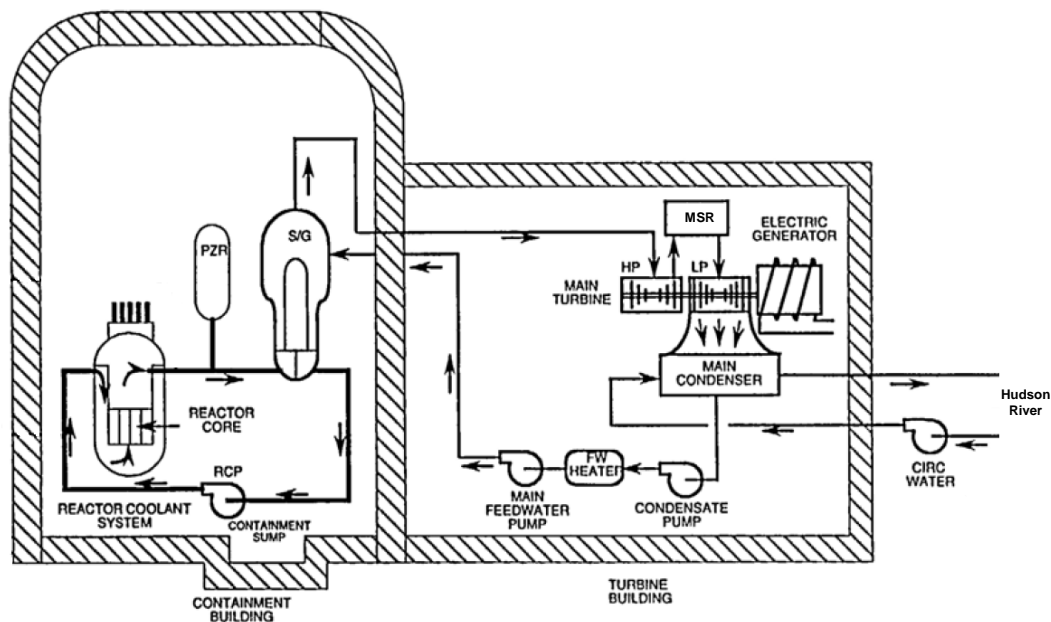

**Figure 2.1 Basic Arrangement of a PWR**

### 2.2.2 Condenser Operation

The objective of the main condenser is to serve as a heat sink (i.e., a mechanism for heat removal) for turbine exhaust steam, turbine bypass steam, steam generator bypass steam,

and other flow [Ref. 6.120]. As such, cooling provided by the condenser is necessary to provide condensed steam (i.e., feedwater) for the steam generators.

Although the Unit 2 and Unit 3 main condensers are not identical, they are similar in that they are of the single pass, divided water box, de-aerating type. Each consists of three shells, one for each low pressure turbine cylinder, and is located directly beneath the low pressure cylinders of the main turbine. The location of the condensers below the low-pressure turbines is indicative of their function, whereby the cooling water of the CW system condenses the steam exhausted from the turbine, which is then returned to the steam generators as feedwater.

Hudson River water is the heat sink for the main condenser and its supported systems. The condenser hotwells are designed for 4-minute storage and are longitudinally divided to facilitate the detection of condenser tube leakages [Ref. 6.60; Ref. 6.64].

Each of the Unit 2 and Unit 3 condensers are rated at the following design parameters [Ref 6.42]:

	<u>Unit 2</u>	<u>Unit 3</u>
Steam condensed	$2.415 \times 10^6$ lbm/hr	$2.453 \times 10^6$ lbm/hr
Heat removed	$2.32 \times 10^9$ BTU/hr	$2.33 \times 10^9$ BTU/hr
Absolute pressure	2.05 in-Hg	2.04 in-Hg
Surface area	315,700 ft <sup>2</sup>	286,125 ft <sup>2</sup>

### 2.2.3 Effluent Treatment Operation

IPEC Unit 2 and Unit 3 have similar systems to process liquid radiological waste (radwaste). Liquid radwaste generated throughout Unit 2 is collected by the waste disposal system (WDS) liquid waste holdup tank (LWHT). The effluent in the LWHT is transferred to the Unit 1 Waste Collection System (WCS), which is comprised of four 75,000 gallon tanks. The effluent from these tanks is sluiced to demineralizer vessels where it is processed using activated charcoal and anion, cation, and macro-reticular resins. The distillate produced by the demineralizer vessels is collected in two distillate tanks. One distillate tank is filled while the other distillate tank is sampled and discharged. When a distillate tank is ready for discharge, it is isolated and sampled to determine the allowable release rate. If the distillate is suitable for release, it is discharged to the Hudson River (via the Unit 1 discharge tunnel). If the contents of the distillate tank are not suitable for release, they are returned to the waste collection tanks for additional processing [Ref. 6.60].

Liquid radwaste generated throughout Unit 3 is stored in three waste holdup tanks. Waste Holdup Tank 31 has a capacity of 24,500 gallons and Waste Holdup Tanks 32 and 33 each have a capacity of 62,000 gallons. If the liquid waste is suitable for discharge from the waste holdup tanks, it can be pumped to one of the two monitor tanks of the Chemical and Volume Control System. When one monitor tank is filled, it is isolated and the effluent is re-circulated and sampled for radiological and chemical analysis while the second tank is in service. If the contents of the monitor tank are suitable for discharge, the effluent is pumped to the Unit 3 SW discharge; otherwise the effluent is returned to the waste holdup tanks for additional processing. Water from the waste holdup tanks can also be pumped

into the demineralization system, which consists of a series of pressure vessels containing activated charcoal and anion, cation, and macro-reticular resins. Effluent processed by the demineralization system is pumped to the Chemical and Volume Control System monitor tanks where it is discharged through the SW discharge or returned to the waste holdup tanks for additional processing [Ref. 6.64].

Unit 2 and Unit 3 have identical systems used to process gaseous waste. Gaseous effluent generated by each Unit discharges to the respective waste gas compressor suction header, where each header flows into one of four gas decay tanks. Any moisture present in the waste gas compressor suction headers is drained to drain tanks that discharge to the WDSs. Gaseous effluent held in the decay tanks can either be returned to the Chemical and Volume Control System holdup tanks, or discharged to the atmosphere if the gases are suitable for release. Discharged gases are released from vents at a controlled rate and, in addition to the effects of normal dispersion, accounting for air turbulence created in the wake of the containment buildings [Ref. 6.60; Ref. 6.64].

## 2.3 Source Waterbody

### 2.3.1 Source Waterbody Description

The lower Hudson River, the source waterbody and heat sink for Unit 2 and Unit 3, is a 152-mile-long tidal estuary extending from the New York Harbor to the Federal Dam at Troy. In the vicinity of IPEC, the Hudson River is approximately 4500 ft wide and 40 ft deep on average, with depths reaching over 60 ft below mean sea level (MSL) just offshore [Ref. 6.82]. The depth directly adjacent to the CWIS is currently dredged to 27 ft below MSL.

The Hudson River in the vicinity of IPEC is subject to a substantial tidal influence and salt water intrusion. All of the lower Hudson River (i.e., from the Federal Dam at Troy to the New York Bay) is tidal, and tidal amplitudes at the Federal Dam average 4.7 ft [Ref. 6.8; Ref. 6.24]. Haverstraw Bay, the location of the closest station to IPEC for which the National Oceanic and Atmospheric Administration (NOAA) publishes data, has a tidal range of 3.23 ft [Ref. 6.81]. There are two flood and two ebb tides within a 24.8-hour interval (i.e., flow past IPEC changes direction by being pushed upstream by salt water tides and pushed downstream by freshwater inflow in a regular tidal rhythm every 12.4 hours), referred to as a “semidiurnal pattern” [Ref. 6.4]. Flow past IPEC during peak tidal flow is approximately 80 million gallons per minute (gpm) [Ref. 6.64]. On average, only 10% of the total lower Hudson River flow is made up by freshwater inflows [Ref. 6.116]. The net downstream flows due to freshwater inflow have been reported to be in excess of 11,670,000 gpm 20% of the time and 1,795,000 gpm 98% of the time [Ref. 6.64]. IPEC is located within the area of the River generally considered brackish, although at certain times in the spring, water in the vicinity of IPEC could be considered fresh due to heavy spring runoff [Ref. 6.24].

The Hudson River can be divided into four salinity zones based on average annual salinities. The mid-estuary section, where IPEC is located, is generally the oligohaline zone (0.5 – 5 parts per thousand salinity). The northern perimeter of this zone marks the

seasonal inland (northernmost) extent of brackish water in the Hudson River. The limits of this zone vary based on the amount of freshwater inflow [Ref. 6.24].

### 2.3.2 Hydraulic Zone of Influence

Several hydrological studies have investigated the Unit 2 and Unit 3 CWISs [Ref. 6.4; Ref. 6.5; Ref. 6.71]. The hydraulic zone of influence establishes where the source of water entering the intake originates, which enables a quantification of the affected volume of the source water body. The combined maximum intake rate calculated for Unit 2 and Unit 3 is approximately 1,762,000 gpm, or just 2.2% of the 80,000,000 gpm average tidal flow rate of the Hudson River [Ref. 6.60]. As shown in Section 2.4.2.3.2, Table 2.1, the average historic combined flow rates for the Stations from 2001 to 2008 is approximately 1,390,000 gpm (2001.2 MGD), and, therefore, makes up only 1.7% of the 80,000,000 gpm average tidal flow rate of the Hudson River.

La Salle Hydraulic Laboratory created a scaled, physical hydraulic model to study Hudson River Flows around the IPEC Stations' CWISs in 1976 [Ref. 6.95]. Water from both downstream and upstream of the Stations supplies the CWIS. The zone supplying water downstream of the Stations was estimated to be 300-350 ft wide. During ebb tide, the study concluded that all water comes to the intakes from a narrow 200-250 ft wide zone upstream of the Stations along the east shore.

Current measurement data collected offshore of IPEC during three tidal cycles showed a maximum flood velocity of 1.5 fps and maximum ebb velocity of 3.3 fps. Based on these maxima, the average flood velocity is 1.0 fps, and the average ebb velocity is 2.1 fps [Ref. 6.11]. The Unit 2 and Unit 3 CWISs have an intake water approach velocity of approximately 1.0 fps at full flow and approximately 0.6 fps at reduced flow [Ref. 6.24].

### 2.3.3 Intake Volume Calculation

In order to characterize the Stations' water use through the CWISs in terms of Hudson River flow, the total design intake volume over one tidal cycle of ebb and flow can be expressed as a percentage of the volume of water column that passes through the area centered about the CWIS opening (4500 ft across, average 40 ft deep). Under 40 CFR §125.83, the tidal excursion is defined as "the horizontal distance along the estuary or tidal river that a particle moves during one tidal cycle of ebb and flow." As noted, the tidal currents in the vicinity of IPEC have an average 12.4 hour tidal cycle of ebb and flow. The maximum tidal excursion for both Units, calculated to be approximately 94,000 ft, is a function of the maximum flow velocity of 3.3 fps [Ref. 6.11] and the tidal period [Ref. 6.114]. Therefore, the volume of Hudson River water flow defined by one tidal excursion at mean low water (MLW) is approximately  $1.26 \times 10^{11}$  gallons for each Unit. The intake volume of Unit 2 over one tidal cycle is approximately  $6.59 \times 10^8$  gallons based on the maximum design cooling water flow of 886,000 gpm (Section 2.4.2.2). For Unit 3 the intake volume over one tidal cycle is approximately  $6.52 \times 10^8$  gallons based on the maximum design cooling water flow of 876,000 gpm (Section 2.4.2.2). As such, the Unit 2 and Unit 3 intake volumes ( $6.59 \times 10^8$  and  $6.52 \times 10^8$  gallons, respectively) each only make up approximately 0.52% of the volume of Hudson River water flow defined by one tidal excursion ( $1.26 \times 10^{11}$  gallons). Note that this percentage of the volume of Hudson River

water flow defined by one tidal excursion is not the same as the percentage of the average tidal flow rate of the Hudson River discussed in Section 2.3.2.

## 2.4 CWIS Description

As noted in Section 2.1, the Stations have once-through CWISs. Screens are typically placed within the CWISs to filter the source waterbody. After passing through the screens, water is pumped out of the intake structure and delivered through piping systems to the main steam condensers (circulating water systems) and to both the essential and non-essential service water headers for cooling purposes. Each Unit has a separate CWIS that houses the circulating water pumps and the service water pumps that are required to provide adequate and reliable flow to the circulating water and service water systems. In addition, several additional technologies are utilized at each CWIS for the purpose of reducing I&E. As further discussed in Section 3, the Stations' existing traveling water screens (TWSs) and fish return systems are considered state-of-the-art for impingement reduction.

### 2.4.1 Physical Description, Location and Depth of CWIS

The Stations' CWISs are located approximately 700 ft apart along the shore of the Hudson River.

#### Unit 2

The Unit 2 CWIS is a shoreline intake structure. In contrast to Unit 3 (discussed below), the Unit 2 above-deck mechanical equipment is not covered by a screen house structure. Figures 5-1 and 5-2 of Attachment 5 show plan and section views of the Unit 2 CWIS.

Concrete wing walls form the north and south ends of the Unit 2 CWIS. The inlet to the Unit 2 CWIS is a concrete manifold partitioned into seven independent intake water channels (screenwells). The channels are separated by three foot thick concrete walls. Six of the channels provide River water to the circulating water (CW) pumps. The purpose of the CW pumps is to provide cooling water to the circulating water system. Each CW channel is 13 feet (ft) 4 inches wide and 42 ft high from the back wall to approximately 11 ft from the entrance. After that point, the channels expand outward to a width of almost 15 ft at the entrance. [Ref. 6.48; Ref. 6.49] The center channel is partitioned into two sections and provides River water to the service water (SW) pumps. The purpose of the SW pumps is to provide cooling water to the service water system. Each SW section is 10 ft wide and 42 ft high [Ref. 6.48; Ref. 6.49]. Gated openings are provided between the SW sections and the adjacent CW channels to allow SW flow to be delivered through the CW TWSs [Ref. 6.59].

The opening to the CWIS has a height of 26 ft and is completely submerged at 1 ft below MSL. The lowest portion of the CWIS is located at an approximate elevation of 27 ft below MSL and the concrete deck is at an elevation of 15 ft above MSL [Ref. 6.49]. A debris wall is located at the entrance to the Unit 2 CWIS. The bottom of the debris wall extends to 1 ft below MSL and is designed to restrict floating materials at or just below the surface from entering the CWIS [Ref. 6.62].

Each of the seven Unit 2 intake channels has a coarse bar rack installed to retain pieces of debris larger than 3 inches. The bar racks are constructed of ½ inch by 3 inch bars spaced

3½ inches apart. The bars are mounted vertically (narrow side toward the flow), running the full height of the intake structure [Ref. 6.62]. Large debris that accumulates in front of the bar racks is manually removed by divers.

Unit 2 has eight Ristroph-type TWSs to remove fish from the intake flow and return them to the Hudson River. Unit 2 has one TWS for each CW intake channel and one for each SW intake section, located between the bar racks and CW pumps. The Stations' TWSs consist of a continuous series of wire mesh panels and curved fish handling buckets attached to frames and attached to two matched strands of roller chains. These panels and buckets are commonly referred to as Ristroph Screens. The TWSs service the six CW pumps (CW pumps 21 through 26) and the six SW pumps (SW pumps 21 through 26). The TWSs, discussed in more detail in Section 2.4.1.1, are specifically designed to remove fish using low pressure spray wash nozzles and return them via fish return troughs that have a smooth finish designed to minimize fish abrasion [Ref. 6.41]. Residual debris larger than ½ by ¼ inch is removed using separate high pressure spray wash nozzles and separate debris troughs.

Stop log gates (i.e., barriers that, when deployed, block flow through an intake channel) are provided for the six CW channels and two SW channel sections and are designed to allow inspection and maintenance of the intake channels. Each stop log gate consists of two steel sections. Guide channels in the intake structure walls facilitate the installation and removal of the stop log gates. Chains attached to the stop log gates assist with installation and removal. When installed, the stop log gates isolate the water intake channel from the Hudson River, allowing de-watering for inspection and maintenance purposes under dry conditions. Each CW channel has a single stop log gate located between the TWS and its associated CW pump. Each of the two SW sections has two stop log gates. The SW stop log gates are located between the TWSs and their associated bar racks and between the TWSs and SW pumps.

During periods of high River water temperature when cooling water demands are the greatest, Unit 2 uses up to 16,000 gpm of supplemental River water from the Unit 1 CWIS. The Unit 1 intake structure consists of a concrete bulkhead divided into four intake channels. Each intake channel is 11 ft 2 inches wide and 26 ft high. The two CW pumps (CW 1 and CW 2) for Unit 1 are no longer in service.<sup>6</sup> Two SW intake channels are located within the Unit 1 CWIS, north and south of the CW pump bays. Each SW intake bay houses a River Water (RW) service pump (Pumps 11 and 12) and two TWS pumps (TWS Pumps 11 through 14). One RW pump is active and the other is a standby, such that only one ever operates. River water is supplied to Unit 2 by RW pumps 11 and 12 through a 10 inch pipe.

### Unit 3

The Unit 3 CWIS is also a shoreline intake structure. The screen house for Unit 3 covers the Unit 3 CWIS with a steel-framed structure enclosed with metal panels. Figures 5-3 and 5-4 of Attachment 5 show plan and section views of the Unit 3 CWIS.

---

<sup>6</sup> For informational purposes, Unit 1 was shut down on October 31, 1974 and currently is managed in safe storage condition (SAFSTOR) prior to final decommissioning.

Concrete wing walls form the north and south ends of the Unit 3 CWIS. The Unit 3 CWIS consists of seven intake channels. The channels are served by a common plenum that is 12 ft wide and 120 ft long. Nine bar racks, the bottom of which are located 1 ft below MSL, form the north, south, and west walls of the plenum. Seven of the bar racks are at the west wall with a single bar rack at the north and south ends of the plenum. The opening of each water intake channel is located 12 ft behind the western bar racks. Each CW channel is 13 ft 4 inches wide and 42 ft high. The center channel is partitioned into two sections and provides River water to the SW pumps. Each SW section is 10 ft wide and 42 ft high. Gated openings are provided between the SW sections and the adjacent CW channels to allow SW flow to be delivered through the CW TWSs. These gated openings are normally kept closed [Ref. 6.62].

The opening to the Unit 3 CWIS has a height of 26 ft and is completely submerged at 1 ft below MSL. The lowest portion of the CWIS is located at an approximate elevation of 27 ft below MSL and the concrete deck is at an elevation of 15 ft above MSL. A debris wall is located at the entrance to the Unit 3 CWIS. The bottom of the debris wall extends to 1 ft below MSL and is designed to restrict floating materials at or just below the surface from entering the CWIS.

Each of the seven intake channels has a bar rack installed to retain pieces of debris larger than 3 inches. The bar racks are constructed of  $\frac{1}{2}$  inch by 3 inch bars that are set  $3\frac{1}{2}$  inches apart. The bars are mounted vertically (narrow side toward the flow), running the full height of the intake structure. A PVC-coated wire mesh screen is attached to the River side of the bar racks and extends from 3 ft above MSL to 4 ft below MSL. This screen mesh prevents smaller floating debris from entering further into the intake and clogging the debris and fish return troughs [Ref. 6.62]. Large debris that accumulates in front of the bar racks is manually removed by divers.

Eight Ristroph-type TWSs, one for each CW channel and one each for the SW intake sections, are located downstream of the bar racks. The TWSs service the six CW pumps (CW pumps 31 through 36) and the six SW pumps (SW pumps 31 thru 36). The TWSs, discussed in more detail in Section 2.4.1.1, are specifically designed to remove any fish using low pressure spray wash nozzles and return them to the River via fish return troughs that have a smooth finish designed to minimize fish abrasion. In addition, debris larger than  $\frac{1}{2}$  by  $\frac{1}{4}$  inch is removed using separate high pressure spray wash nozzles and separate debris troughs. Unit 3's stop log gates are similar to those at Unit 2.

#### **2.4.1.1 Current Traveling Water (Ristroph) Screens**

The CWISs at Units 2 and 3 have modified vertical Ristroph-type traveling water screens. These screens were installed following a collaborative research effort among the former owners of the Stations and the Hudson River Fisherman's Association (HRFA), now Riverkeeper, Inc. (Riverkeeper), directed by Dr. Ian Fletcher, then-consultant for the HRFA. The effectiveness of the existing Ristroph-type TWS screens at reducing impingement losses (as compared to angled or traditional traveling screens<sup>7</sup>) is documented in Flow Dynamics and Fish Recovery Experiments: Water Intake Systems

---

<sup>7</sup> These screen types are discussed in more detail in Section 4.2.



(Fletcher Article) [Ref. 6.33]. Dr. Fletcher concluded that Station improvements, beyond the Ristroph-type TWSs installed, were unlikely to significantly reduce impingement losses. Therefore, the existing screens at the Stations are state-of-the-art in terms of minimizing impingement [Ref. 6.33]. In addition, the Fletcher Article [Ref. 6.33] indicates that the NYSDEC adopted the performance of these screens as the State's best technology available for reducing impingement.

The Stations' existing TWS assemblies in the CW intake channels are 13 ft 4 inches wide and 46 ft high. The heights are measured from the center of the head shaft to the center of the tail shaft. The TWSs in the SW intake sections are 8 ft 9 inches wide (north sections) or 7 ft 2 inches wide (south sections) and are each 46 ft high. Each screen is installed in a channel with the screening surface oriented perpendicular to the water flow with each screen including 52 basket segments. The chain rotates over head and foot sprockets, carrying the panels down into the water and around the foot sprockets, then back up through the water and over the head sprockets.

Water passes first through the ascending and then the descending screen baskets, which are constructed of stainless steel 14-gauge oblong-shaped mesh and are framed in a 316L stainless steel structure [Ref. 6.41]. The basket mesh has a ¼-inch wide by ½-inch tall spacing with a total open area of 70.6% [Ref. 6.41; Ref. 6.94]. As discussed further in Section 2.4.2.4, the through-screen velocity for the Unit 2 and Unit 3 CW traveling water screens is 1.61 fps at MLW.

The Ristroph-type TWSs at the Stations are automatically-cleaned screening devices specifically designed to gently remove aquatic species from a channel of flowing water. The ascending basket is located on the western side of the screen facing the CWIS opening and collects fish as it passes up through the water. Aquatic species are collected in the buckets that form the lower (trailing) edge of the mesh frame. A high pressure spray (80-100 psi), specifically designed to avoid the contents of the fish handling buckets, is used to remove any debris impinged on the basket mesh into the front debris trough [Ref. 6.41]. As the baskets rotate around the head sprocket, the contents of the buckets descend on the incline of the mesh panel where three low pressure sprays (10-15 psi) are used to direct impinged fish into the fish return trough [Ref. 6.41]. The baskets continue to descend towards an additional high pressure spray (80-100 psi) that removes any remaining debris into the rear debris trough. As the baskets continue to revolve towards the foot sprocket, any fish and debris that were not originally washed off the screens may be washed off in the flow of water. This fish and debris is considered to be 'carryover' and could potentially enter the CW pump intake.

The TWSs ordinarily operate continuously at 2.5 feet per minute (fpm). The TWSs operate at 10 fpm when a high differential pressure is detected across the screens, indicating a large buildup of debris, until that buildup is cleared. Electric radiant heating elements, installed in the driving head of the TWSs, are energized when the temperature is below 35°F to prevent ice from forming.

Figure 2.2 shows a schematic of the Station's TWS configuration.

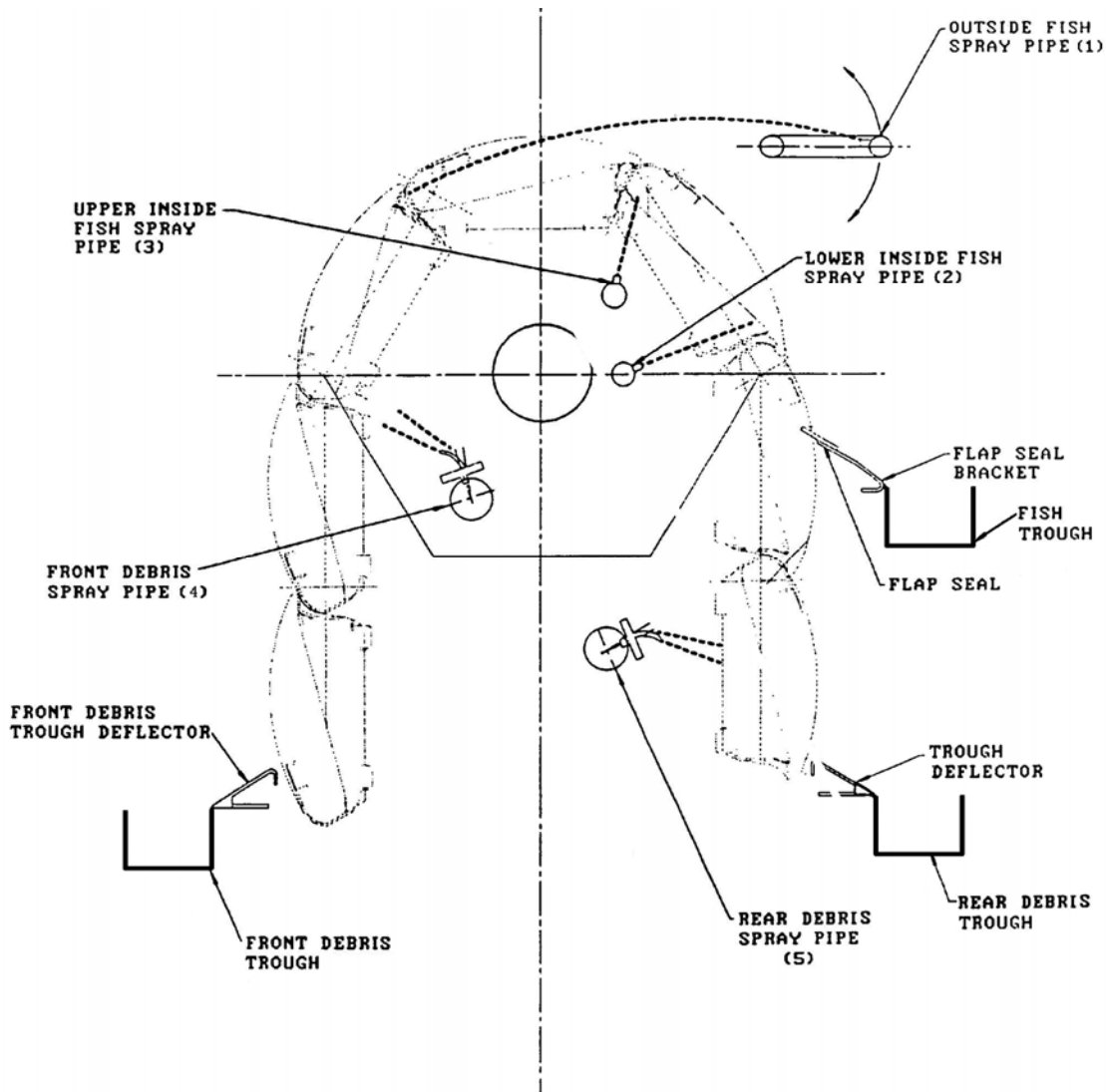

**Figure 2.2 TWS Operation**

### 2.4.1.2 Fish Handling and Return System

The fish handling and return systems at the Stations consist of a series of low pressure water sprays used to transfer fish to fish return troughs that return those fish to the Hudson River. Residual debris is removed via separate high pressure water sprays and debris return troughs. Prior to the installation of each Unit's fish return systems, extensive studies were conducted, and prototype fish return system models were designed. The design and testing of the fish return systems were conducted under the oversight of Dr. Ian Fletcher, consultant for Riverkeeper's predecessor, between 1989 and 1992, with the objective of maximizing fish survival and minimizing reimpingement [Ref. 6.9; Ref. 6.111]. As discussed in Section 2.4.1.1, Dr. Fletcher concluded that Station improvements, beyond the installed Ristroph-type TWSs, were unlikely to significantly reduce impingement losses. Therefore, the existing screens at the Stations are state-of-the-art in terms of minimizing impingement [Ref. 6.33].

The mesh panels and buckets of the traveling water screens are lifted out of the flow and above the operating floor where low pressure and high pressure water spray is directed outward through the mesh to remove impinged fish and debris, respectively. As shown in Figure 2.2, each TWS has three low pressure spray nozzles (10-15 psi) (labeled as fish spray pipes) and two high pressure spray nozzles (80-100 psi) (labeled as debris spray pipes). The fish and debris handling systems consist of three different trough systems. The fish return troughs are located on the east side of the traveling screens. The main (rear) debris troughs are on the east side of the traveling screens below the fish return troughs. The auxiliary (front) debris troughs are located on the west side of the traveling screens [Ref. 6.54]. The locations and elevations of the fish return and debris return troughs correspond with the sequence of high pressure and low pressure spray used to direct fish and debris from the mesh panels.

The Unit 2 and Unit 3 TWSs have separate fish return systems. Both of these intakes have rectangular fish return troughs with clear widths of 36 inches and depths of 12 inches. Unit 2 has one fish return trough for TWSs 21 and 23 and another fish return trough for TWSs 24 and 26. Separate fish return troughs are provided for these adjoining TWS to avoid interferences with the SW TWS screens. Bends and vertical offsets are located south of TWS 21 and north of TWS 26 and transition the fish return troughs into below deck sluices (i.e., slides or chutes) that are approximately 20 inches wide and 12 inches deep. The fish return sluices merge north of the Unit 2 TWSs and transition into a 14-inch diameter fish return pipe that extends 185 ft into the Hudson River, north of the intake structure, at a depth of approximately 34 ft below MSL.

The Unit 3 fish return trough slopes downward between TWSs 31 through 36. South of TWS 31, the fish return trough transitions into a fish return sluice that has identical dimensions. This sluice is located above the concrete deck and runs approximately 113 ft south before transitioning through a 20 ft section into a 10-inch fish return pipe. The fish return pipe runs approximately 148 ft prior to discharging at the northwest corner of the discharge canal at a depth of approximately 10 ft below MSL.

The fish return troughs and sluices are fabricated from ½-inch thick fiberglass. The troughs are designed to maintain a design water depth of approximately 2 inches and a design water velocity between 2-5 fps. The fish return troughs are covered with removable covers or grates in areas where personnel may travel.

Both the main and auxiliary debris troughs are rectangular and have an inner width of 22 inches and an inner depth of 9 inches. The debris troughs are also fabricated from fiberglass and merge prior to transitioning through rounded elbow sections that discharge into the combined debris flume. The combined debris flume travels along the west side of each CWIS and is rectangular with a constant width of 24 inches and varying depths up to 36 inches, with bends ranging from 12 degrees to 45 degrees [Ref. 6.56]. The debris troughs and flume are constructed of fiberglass. South of the Unit 3 CWIS, the combined debris flume transitions into a 14-inch diameter debris pipe that discharges into the discharge canal approximately 217 ft south of the flume at a depth of 6 ft 3 inches below MSL.

## 2.4.2 CWIS Flow Description

As detailed in Section 2.4.1, two primary CWISs supply the Stations with cooling water; one CWIS supplies cooling water to Unit 2, and the other CWIS supplies cooling water to Unit 3. Additional flow from the Unit 1 RW pump can be used to supplement the Unit 2 SW System. There are two distinct cooling water flow values: the baseline flow rate (i.e., maximum design intake capacity) and the average actual intake flow rate. The baseline flow rate, or maximum design intake capacity, is used to design all CWIS screening technologies, and represents the maximum flow value. Baseline flow (maximum design intake flow) means the cooling water design flow values and consists of the following: (1) the condenser cooling water flow through the circulating water pumps, and (2) the service water flow that serves an equipment cooling function. Baseline flow equates to the value assigned, during the cooling water intake structure design, to the expected total volume of water likely to be withdrawn from a source waterbody for cooling purposes, consistent with 40 CFR §125.93 and both as reflected in and consistent with the Updated Final Safety Analysis Report (UFSAR) for each Unit [Ref. 6.60; Ref. 6.64]. The average actual flow rate is the average historical amount of flow entering the CWIS. The average actual flow rate is smaller than the design flow rate, due to lesser flows resulting from outages and periods of reduced cooling demands allowing flow reductions through the use of the dual and variable speed pumps at Units 2 and Unit 3, respectively. Cooling water flow diagrams for the Station' CW and SW systems are shown in Figures 5-5 through 5-8 of Attachment 5. Screenwash water (i.e., water supplied to the screenwash pumps) is not included in the baseline flow rate or the average actual flow rate.

### 2.4.2.1 Pump Descriptions

#### 2.4.2.1.1 Cooling Water Pumps

##### Unit 2

The following sets of pumps supply cooling water to Unit 2:

- The Unit 2 dual speed CW pumps supply once-through cooling water for the CW system from the Unit 2 CWIS. Each of the six CW pumps has a maximum design intake capacity of 140,000 gpm, combining for a total of 840,000 gpm. As shown in Figure 5-5 of Attachment 5, the CW pumps supply Unit 2 Condensers 21, 22, and 23.
- The Unit 2 SW pumps supply River water from the Unit 2 CWIS as a cooling medium to those systems or components requiring heat removal during normal or abnormal plant conditions. The Unit 2 SW pumps also provide screenwash water to TWSs #27 and #28 located in the SW intake channel sections. As shown in Figure 5-6 of Attachment 5, the SW system consists of two supply headers, essential and non-essential, each provided with River water by three SW pumps. The essential header supplies the components requiring cooling during a station blackout or loss of coolant accident. Each of the six SW pumps has a maximum design intake capacity of 5000 gpm, combining for a total of 30,000 gpm.

- The Unit 1 RW pump can supply additional cooling River water from the Unit 1 CWIS to the non-essential Unit 2 SW header. One RW pump has a maximum design intake capacity of 16,000 gpm. The second RW pump is a standby pump and is not included as part of the baseline flow because it does not add to the intake capacity.

### **Pump Specifications**

#### Dual Speed Circulating Water Pumps (6)

- Allis Chalmers Model 96 x 84 YDDVRM
- Each pump is a dual speed pump rated for 140,000 gpm at 21 ft total dynamic head (TDH) when running at 254 revolutions per minute (rpm), and 84,000 gpm at 15 ft TDH when running at 187 rpm. Each pump is driven by a vertical solid shaft squirrel cage induction motor rated for 1000/400 hp at 254/187 rpm, 6600 volts, three phase, 60 Hertz. Dual speed operation is achieved via two sets of motor windings.

#### Service Water Pumps (6)

- Johnston Pump Company Model 18EC-2 Stage
- Each pump is rated for 5000 gpm at 212 ft TDH and driven by a motor rated for 350 hp at 1800 rpm, 480 volts, three phase, 60 Hertz.

#### River Water Pumps (2)

- Allis Chalmers
- The pump is rated for 16,000 gpm and driven by a motor rated for 500 hp at 600 rpm, 440 volts.

### Unit 3

The following sets of pumps supply cooling water to Unit 3:

- The Unit 3 variable speed CW pumps supply once-through cooling water for the CW system from the Unit 3 CWIS. Each of the six CW pumps has a maximum design intake capacity of 140,000 gpm, combining for a total of 840,000 gpm. As shown in Figure 5-7 of Attachment 5, the CW pumps supply Unit 3 Condensers 31, 32, and 33.
- The Unit 3 SW pumps supply River water from the Unit 3 CWIS as a cooling medium to those systems or components requiring heat removal during normal or abnormal plant conditions. As shown in Figure 5-8 of Attachment 5, the service water system consists of two supply headers, essential and non-essential, each provided with River water by three SW pumps. The essential header supplies the components requiring cooling during a station blackout or loss of coolant accident. Each of the six SW pumps has a maximum design intake capacity of 6000 gpm, combining for a total of 36,000 gpm. Three SW backup pumps are available at Unit 3 and each can supply 5000 gpm. The SW backup pumps take

suction from the Unit 2 discharge tunnel and provide flow to the essential and non-essential nuclear services headers.

### **Pump Specifications**

#### Variable Speed Circulating Water Pumps (6)

- Allis Chalmers Model 102 x 84 YDDVRM
- Each pump is driven by a variable speed drive and is rated for 140,000 gpm at 29 ft TDH when running at 360 rpm and 84,000 gpm at 19.5 ft TDH when running at 250 rpm. Each pump is driven by a vertical solid shaft squirrel cage induction motor rated as 1250 hp at 250 rpm, 6900 volts, three phase, 60 Hertz.

#### Service Water Pumps (6)

- Ingersoll-Rand Model 26 APK-1
- Each pump is rated for 6000 gpm at 195 ft TDH. Each pump is driven by a motor rated as 350 hp at 1785 rpm, 480 volts, three phase, 60 Hertz.

#### Backup Service Water Pumps (3)

- Layne & Bowler Pump Company – Specification #4756-9321-05-238-22
- Each pump is rated for 5000 gpm at 220 ft of total dynamic head. Each pump is driven by a Westinghouse motor rated as 350 hp at 1770 rpm, 440 volts, three phase, 60 Hertz.

### **2.4.2.1.2 Screenwash Water Pumps**

#### Unit 2

The following sets of pumps supply screenwash water for Unit 2:

- The Unit 2 CW screenwash system is provided with River water by screenwash pumps located in the Unit 1 intake structure. Each of these 4 screenwash pumps is rated at 2000 gpm, combining for a total of 8000 gpm.
- The Unit 2 SW pumps normally provide screenwash water for the TWSs in the SW channel sections via the SW non-essential header. TWSs #27 and #28 are each provided with up to 164 gpm.

### **Pump Specifications**

#### Screenwash Pumps (4)

- Goulds Pumps Model VIT-CF
- Each pump is rated for 2000 gpm at 234 ft of total dynamic head. Each pump is driven by a motor rated as 150 hp at 1780 rpm, 480 volts, three phase, 60 Hertz.

#### Unit 3

The following sets of pumps supply screenwash water for Unit 3:

- The Unit 3 screenwash pumps take suction from CW intake channels #34, #35, and #36 downstream of the traveling water screens. Each of the 3 screenwash pumps is rated for 3200 gpm, combining for a total of 9600 gpm.

### **Pump Specifications**

#### Circulating Water Screenwash Pumps (3)

- Ingersoll-Rand Model 24 APK-1
- Each pump is rated for 3200 gpm at 250 ft of total dynamic head. Each pump is driven by a motor rated as 250 hp at 1785 rpm, 460 volts, three phase, 60 Hertz.

### **2.4.2.2 Design Intake Capacity**

NYSDEC regulations do not define water sources subject to 6 NYCRR §704.5. However, the United States Environmental Protection Agency (EPA) defines cooling water as "...water used for contact or non-contact cooling, including water used for equipment cooling, evaporative cooling tower makeup, and dilution of effluent heat content." (See 69 Fed. Reg. 41576, 41684, July 9, 2004; 40 CFR Part 125, §125.93). Screenwash water (i.e., the water supplied to the screenwash pumps) is not regulated by EPA and is included here for informational purposes only. Consistent with EPA regulations, in this Report the baseline flow of the Stations is comprised of the cooling water design intake capacities.

### **Cooling Water Design Intake Capacity**

#### Unit 2

Under normal power generating operation, the Unit 2 SW pumps and the CW pumps can draw in 870,000 gpm of cooling water from the Unit 2 CWIS. The Unit 1 RW pumps can draw in 16,000 gpm of cooling water to supplement the Unit 2 SW System. Unit 2 has a maximum design intake capacity for cooling water as follows:

#### Cooling Water Design Intake Capacity (886,000 gpm)

- Up to 840,000 gpm from the Unit 2 CW pumps is used as non-contact cooling water<sup>8</sup> in the condenser [Ref. 6.60, Section 10.2.4].
- Up to 30,000 gpm from the Unit 2 SW pumps is used as non-contact cooling water for the essential and non-essential heating loads<sup>9</sup> [Ref. 6.60, Section 9.6.1].
- Up to 16,000 gpm from the Unit 1 RW pump is used as non-contact cooling water for the Unit 2 non-essential SW heating loads [Ref. 6.57].

Unit 2 accounts for approximately 50.3% of the total cooling water design intake capacity for the Stations.

<sup>8</sup> Non-Contact Cooling Water is water used to reduce temperature which does not come in direct contact with any raw material, intermediate product, a waste product or finished product.

<sup>9</sup> The essential loads are those which must be supplied with cooling water immediately in the event of a blackout and/or loss of coolant accident. The cooling water for these loads is supplied by the nuclear SW header. The non-essential loads are those which are supplied with cooling water from the conventional SW header.

### Unit 3

Under normal power generating operation, the SW pumps and the CW pumps can draw in 876,000 gpm of water from the Unit 3 CWIS. Unit 3 has a maximum design intake capacity for cooling water as follows:

#### Cooling Water Design Intake Capacity (876,000 gpm)

- Up to 840,000 gpm from the Unit 3 CW pumps is used as non-contact cooling water in the condenser [Ref. 6.64, Section 10.2.4].
- Up to 36,000 gpm from the Unit 3 SW pumps is used as non-contact cooling water for the essential and non-essential heating loads [Ref. 6.64, Section 9.6.1]. Backup service water pumps are standby pumps and are not included because they do not add to the intake capacity.

Unit 3 accounts for approximately 49.7% of the total cooling water design intake capacity for the Stations.

### **Screenwash Water Design Intake Capacity**

#### Unit 2

The Unit 2 traveling water screens (TWSs #27 and #28) can use screenwash water from the discharge of the Unit 2 SW pumps. Water from screen wash pumps #21 through #24 located in the Unit 1 CWIS is also used to supply screenwash water to Unit 2. Unit 2 has a design intake capacity for screenwash water as follows:

#### Screenwash Water Design Intake Capacity (8328 gpm)

- Up to 328 gpm (164 gpm per screen) can be supplied to traveling water screens #27 and #28 during regular operation from the discharge of the Unit 2 SW pumps.
- Up to 8000 gpm (4 pumps at 2000 gpm) from the screen wash pumps in the Unit 1 CWIS can be supplied to the TWSs servicing the CW channels. This flow can also be used as a backup source of wash water to TWSs #27 and #28.

#### Unit 3

The Unit 3 screenwash pumps can draw in screenwash water from the Unit 3 CWIS. Unit 3 has a design intake capacity for screenwash water as follows:

#### Screenwash Water Design Intake Capacity (9600 gpm)

- Up to 9600 gpm (3 pumps at 3200 gpm) is supplied to the screenwash pumps during regular operation. The screenwash pumps take suction from circulating water intake channels #34 thru #36 following the traveling water screens.

### **2.4.2.3 Flow Reductions from Baseline**

It is generally assumed that a direct linear (1:1) relationship exists between flow reduction and the number of fish entrained or impinged. Periods of reduced power at each Unit contribute to reduced intake flow as well as use of the Stations' existing dual/variable speed pumps. When scheduled, these flow reductions represent a reduction



in the baseline flow and are, therefore, considered to be an operational measure to reduce I&E.

#### 2.4.2.3.1 Maintenance & Refueling Outages

At the Stations, maintenance and refueling outages (i.e., scheduled outages) are currently scheduled to occur approximately every 24 months for each Unit, and are anticipated to last approximately 25 days. Scheduled outages are staggered so that both Units are not offline at the same time. When a Unit is offline, some CW and SW would still be present after shutdown and prior to startup. Adequate SW flow must also be provided when the Unit is offline in order to maintain essential cooling of nuclear safety-related systems, including the containment cooling and recirculation systems, component cooling systems, instrument air cooling systems, radiation monitoring cooling systems, and, emergency diesel generator cooling systems. Therefore, even during outages some flow is drawn through the CWISs for CW and SW system cooling needs.

#### 2.4.2.3.2 Historic Operational Intake Flow Rate

Outages and periods of reduced power decrease the actual amount of flow entering the CWIS. When scheduled, these flow reductions represent a reduction in the baseline flow and, therefore, are considered to be an operational measure to reduce I&E.

The Stations supplied eight years (2001-2008) of measured intake flow data for Units 2 and 3, in millions of gallons per day (MGD); the Unit 2 data includes CW, SW, and Unit 1 RW flow, and the Unit 3 data includes CW and SW flow. Table 2.1 shows the monthly and annual average historic flows for the Stations. The average annual historic (2001-2008) intake flow rate<sup>10</sup> for Unit 2<sup>11</sup> is 1102.2 MGD, which represents a 13.6% reduction in flow from the baseline flow value of 1275.8 MGD. For Unit 3, the annual average historic intake flow rate is 899.0 MGD, which represents a 28.7% reduction in flow from the baseline flow value of 1261.4 MGD.

**Table 2.1 Average Historic Flow Rates (2001-2008)  
in Millions of Gallons per Day (MGD)**

Month	Unit 2	Unit 3
January	1001.1	600.1
February	924.1	583.2
March	908.4	500.9
April	940.5	614.8
May	1107.5	899.6
June	1243.6	1199.1

<sup>10</sup> The average annual historic (2001-2008) intake flow rate is a weighted average determined using the number of days in each month with respect to the number of days in one year.

<sup>11</sup> All Unit 1 RW flow is considered to be Unit 2 historic operational SW flow.

Month	Unit 2	Unit 3
July	1248.7	1227.1
August	1252.3	1217.4
September	1253.2	1234.8
October	1209.1	1170.1
November	1007.8	806.5
December	1115.3	715.2
Average Annual	1102.2	899.0

The differences in Unit 2 and Unit 3 flow rates can be attributed to several factors. First, the SW capacity at Unit 2 (SW is 30,000 gpm and RW is 16,000 gpm) is greater than the SW capacity at Unit 3 (36,000 gpm). In addition, the condensers and low pressure turbines at each Unit have different designs, efficiencies, and operational requirements that necessitate substantially different flow requirements. Furthermore, Unit 2 has more issues with debris loading than Unit 3, requiring more flow to clean the systems.

#### 2.4.2.4 Through-Screen Velocity

According to 40 CFR §125.94, if a facility reduces the through-screen velocity to at or below 0.5 fps, it is “deemed to have met the impingement mortality performance standards”. Based on the maximum design intake capacity through each CWIS (cooling water and screenwash water) and a mean low water (MLW) elevation (i.e., 1.0 ft below MSL), the through-screen velocity can be approximated by using the following equation and inputs [Ref. 6.94]:

$$\text{Through-Screen Velocity} = Q / (\text{BW} * \text{LW} * \text{POA} * \text{K})$$

where

Q is the flow rate in gpm

BW is the screen width in feet

LW is the depth at MLW in feet (26.0 ft<sup>12</sup>)

POA is the “percent open area” of the screen basket

K is a conversion factor based on screen type (396 for through flow screens)

<sup>12</sup> LW depth is the difference between MLW elevation (-1.0 ft MSL) and the elevation of the bottom of the CWIS (-27.0 ft).

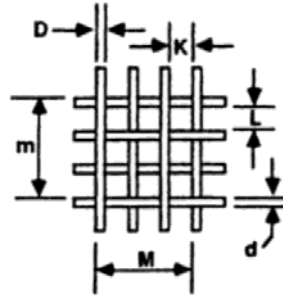

POA for rectangular-mesh screens can be approximated by using the following equation and inputs [Ref. 6.94]:

$$\text{Percent Open Area} = ((K*L)/(K+D)(L+d))*100$$

where

K is the width of the opening (inches)

L is the length of the opening (inches)

D is the warp wire<sup>13</sup> diameter (inches)

d is the shute wire<sup>14</sup> diameter (inches)

### Unit 2

The maximum design intake capacity for the CW system at Unit 2 is approximately 140,000 gpm per channel. The six traveling water screens for the CW channels in the Unit 2 CWIS have a screen width of 12 ft and a depth of 26 ft at MLW. The percent open area is 70.55% based on a warp wire diameter and shute wire diameter of 0.064 inches (14-gauge wire) and mesh opening size of 1/2 x 1/4-inches. Based on these inputs, the through-screen velocity for the CW traveling water screens is 1.61 fps at MLW.

The maximum design intake capacity for the SW system at Unit 2 is approximately 30,000 gpm. The two traveling water screens for the SW channel sections have a screen width of 5 ft 11 inches and a depth of 26 ft at MLW. The percent open area is 70.55%. Based on these inputs, the through-screen velocity for the Unit 2 SW traveling water screens is 0.35 fps at MLW.

### Unit 3

The maximum design intake capacity for CW intake channels #31 through #33 is approximately 140,000 gpm. The maximum design intake capacity for the CW intake channels #34 through #36 is approximately 143,200 gpm (one CW pump and one screenwash pump in each channel). The six traveling water screens for the CW channels in the Unit 3 CWIS have a screen width of 12 ft and a depth of 26 ft at MLW. The percent open area is 70.55%. The through-screen velocity for the traveling water screens in CW channels #34 through #36 is 1.64 fps at MLW. Traveling water screens #31 through #33 have a through-screen velocity of 1.61 fps at MLW.

<sup>13</sup> Warp wire runs the length of the mesh.

<sup>14</sup> Shute wire runs the width of the mesh.

The maximum design intake capacity for the SW system at Unit 3 is approximately 36,000 gpm. The two traveling water screens for the SW channel sections have a screen width of 5 ft 11 inches and a depth of 26 ft at MLW. The percent open area is 70.55%. Based on these inputs, the through-screen velocity for the Unit 3 SW traveling water screens is 0.42 fps at MLW.

#### **2.4.2.5 Seasonal Changes in CWIS Operation**

Unit 2 and Unit 3 have dual speed pumps and variable speed pumps, respectively, that allow the volume of River water withdrawn to be reduced when colder River water temperatures are available. The Stations use best reasonable efforts to operate the Unit 2 and Unit 3 dual/variable speed pumps so as to keep the volume of River water withdrawn at the minimum required for efficient operation, considering ambient River water temperature, plant operating status, and the need to meet SPDES permit conditions [Ref. 6.86; Ref. 6.89].

Also, the conventional, non-essential service water header for Unit 2 can be supplied with supplemental River water from the Unit 1 River Water service header during periods of high River water temperature. This is known as three-header operation, and is the preferred operating mode when the River water temperature is greater than 65°F [Ref. 6.58] (i.e., during periods of high River water temperature, additional flow is required to satisfy the heat rejection requirements of the SW system).

#### **2.4.3 Biocide Treatment**

The CW and SW systems for Unit 2 and Unit 3 are protected from marine growth (micro-fouling) and mussels (macro-fouling) with biofouling control. The biofouling control is implemented by the application of sodium hypochlorite through injection headers and diffusers located in the River water intake channels behind the traveling water screens and before the CW and SW pumps. All of the positive displacement pumps are operated manually and take suction from sodium hypochlorite storage tanks.

In accordance with the SPDES permit [Ref. 6.86], the SW systems may be chlorinated continuously, while chlorination of the CW systems is limited to two hours per unit per day and a total of nine hours per week. In addition, chlorination of the CW systems must be performed during the day, and the CW systems for the two units cannot be chlorinated simultaneously. The chlorination systems are removed from service when the average River water temperature is below 40°F or if the onsite chemistry and engineering departments determine that there is no benefit from continued chlorination.

### **2.5 Discharge System**

The CW Systems provide once-through cooling water to the condensers, and the SW Systems supply cooling water to various nuclear components and conventional components (e.g., Emergency Diesel Generators, Closed Cooling Water Heat Exchangers, etc.). The water from each system is discharged back to the Hudson River through a common discharge canal. As discussed in Unit 3 UFSAR, the Hudson River has been designated as the Ultimate Heat Sink (i.e., the source of cooling water provided to dissipate reactor decay heat and essential cooling system heat loads after reactor shutdown) because it is capable of supplying a reliable, long-

term source of cooling water [Ref. 6.64]. As such, the River provides a nuclear safety function.

### Unit 2

Water for the CW System passes from the Unit 2 CWIS through the condenser and is then discharged via six 96" outside diameter (OD) pipes into a 20 ft wide discharge tunnel, approximately 150 ft long running NE to SW. Water for the SW system is also discharged into the Unit 2 discharge tunnel. From the Unit 2 condenser outlet, the discharge tunnel turns and travels approximately 60 ft SE to NW to an adjustable weir. The outfall from the weir discharges into the common discharge canal for Units 1, 2, and 3 [Ref. 6.50; Ref. 6.51].

### Unit 3

Water for the CW System passes from the Unit 3 CWIS through the condenser and is then discharged via six 96" OD pipes into a 20 ft wide discharge tunnel, approximately 140 ft long running NE to SW. Water for the SW system is also discharged into the Unit 3 discharge tunnel. From the Unit 3 condenser outlet, the discharge tunnel turns and travels approximately 60 ft SE to NW to an adjustable weir. The outfall from the weir discharges into a 100 ft long channel prior to joining the common discharge canal for Units 1, 2, and 3 [Ref. 6.52; Ref. 6.53].

### Common Discharge Canal

The common discharge canal for Units 1, 2 and 3 runs northeast to southwest for approximately 700 ft underneath and alongside the Unit 1 and Unit 3 turbine buildings, respectively [Ref. 6.43; Ref. 6.44; Ref. 6.53]. This portion of the discharge canal is approximately 36 ft wide. The common discharge canal turns towards the River after reaching the Unit 3 discharge tunnel inlet, running NE to SW for approximately 260 ft [Ref. 6.45; Ref. 6.53]. The common discharge canal runs approximately 240 ft along the River bank prior to reaching the 255 ft wide common outfall (i.e., Outfall 001) [Ref. 6.45; Ref. 6.86].

The outfall is comprised of twelve sub-surface diffuser ports (4 ft tall by 15 ft wide spaced 21 ft apart, center to center) which are located 12 ft beneath the water surface (at MLW) along the west wall of the discharge canal. Two of the twelve discharge ports have fixed gates that are normally closed and ten have adjustable gates that are mechanically aligned to maintain a differential head of 1.75 ft across the outfall structure. These gates are used to assure the minimum discharge velocity of 10 fps required for adequate mixing of the discharge water with Hudson River water [Ref. 6.63]. The first port is approximately 600 ft south of the Unit 3 intake structure [Ref. 6.24]. The separation between the intake and the discharge is designed to minimize recirculation of warmed discharge effluent. Discharge temperatures are limited in accordance with the SPDES Permit [Ref. 6.64].

The outfall structure and relevant land are leased to Entergy by the New York State Energy Research and Development Authority (NYSERDA). This lease is dated July 1, 1971 and is subject to renewal on March 31, 2017 [Ref. 6.92].

## 2.6 Cooling System Equipment

Table 2.2 describes the significant installation, maintenance, and replacement dates for equipment and components used in the Stations' cooling systems.

**Table 2.2 History of Key CWIS Components at Unit 2 and Unit 3**

Equipment	Originally Installed	Date and Description of Component Replacement
<b>Unit 2</b>		
Bar Racks	1974	Original still in place.
Service Water Sluice Gates	1974	1985, Replaced the original pneumatically operated sluice gates installed between the service water and circulating water bays in the intake structure due to corrosion.
Traveling Screens	1974	1983, Installed fine mesh screens in the intake structure at the inlet to the service water pump bays. 1984, Installed spray wash piping that is used to clean the fine screens. 1985, Installed Ristroph Screen in screen well 26 for survival testing. 1991, Installed Ristroph Screens. 2007, Replaced traveling water screen 25.
Fish Return System	1997	Original still in place.
Screen Wash Pumps	1974	1991, Replaced with four Goulds Pumps Model VIT-CF.
Service Water Pumps 21 through 26	1974	1998, Replaced Layne & Bowler and Aurora service water pumps with pumps manufactured by Johnston Pumps Company. Previous pumps required frequent maintenance. Existing motors were reused. 2006, Replaced motor in SWP 25.
Hypochlorite Injection Pumps	1974	1986, Install two diffusers to continuously chlorinate service water bays. 1993, Installed saran lined piping connected to diffusers located in stop log frames for TWSs 27 and 28. Two chlorine monitors and two zebra mussel monitors were also installed at this time. 2003, Installed two 5000 gallon hypochlorite storage tanks.
Circulating Water Pumps 21 through 26	1974	1985, Installed Allis Chalmers dual speed circulating water pumps. 1986, Installed 2 metering pumps and piping. 1990, Installed 3 metering pumps. 2001, Replaced SSW Hypochlorite piping. 2003, Replaced CWP 26 Motor and expansion joint. 2004, Replaced CWP 22 Motor rotating element.
<b>Unit 3</b>		
Bar Racks	1976	1992, Replaced upper bar racks. 1996, Installed wire mesh above the racks to keep out floating debris. 2009, Replaced upper and lower bar racks.
Service Water Sluice Gates	1976	Original still in place.

**Table 2.2 History of Key CWIS Components at Unit 2 and Unit 3**

Equipment	Originally Installed	Date and Description of Component Replacement
Traveling Screens	1976	1986, Installed traveling water screen to provide redundancy in the event of a blocked screen. 1988, Replaced traveling water screen 37 and piping providing screenwash water to this screen due to severe deterioration. 1989, Replaced traveling water screen 36. 1994, Installed Ristroph Screens.
Fish Return System	1994	Original still in place.
Screen Wash Pumps	1976	1994, Replaced with Ingersoll Rand 24 APK-1 pumps.
Service Water Pumps 31 through 36	1976	1988, Replaced existing Layne and Bowler pumps with Ingersoll Rand single stage pumps to prevent suction of debris from bottom of Intake Structure and minimize vibration. Fiberglass baffling added in front of new pumps to prevent hydraulic interactions between the pumps. Ingersoll Rank 26 APK-1 pumps are rated for 6000 gpm at 195 ft of total dynamic head.
Service Water Pumps 37 through 39	1976	1994, Permanent installation of chlorination nipple, valves, and cap.
Hypochlorite Injection Pumps	1976	1995, Replace existing storage tank with an 1800 gallon tank manufactured by Composites USA, Inc. Replacement tank is insulated with moisture resistant insulation. 1998, Replaced continuous chlorination pumps 31 and 32. 2008, Replaced hypochlorite storage tank.
Circulating Water Pumps 31 through 36	1976	1989, Allis Chalmers variable speed circulating water pumps installed. 1986, Installed 2 metering pumps and piping. 1990, Installed 3 metering pumps. 2001, Replaced SSW Hypochlorite piping. 2003, Replaced CWP 32.

Note that the traveling water screens and other CWIS equipment routinely undergo preventative maintenance and periodic refurbishments that are not accounted for here.

## 2.7 License Status

Applications were submitted to the NRC to renew the respective Unit 2 and Unit 3 operating licenses for an additional 20 years under 10 CFR Part 54 on April 30, 2007. For Unit 2 and Unit 3, the requested renewals would extend the license expiration dates to midnight September 28, 2033, and midnight December 12, 2035, respectively [Ref. 6.24].

### **3 Existing CWIS Technologies and Operational Measures that Affect I&E**

This section describes existing Station intake technologies. The Stations also employ operational measures that can affect I&E. EPA has defined a uniform baseline configuration (40 CFR §125.93) designed to ensure consistent decision-making among different facilities as follows:

...the cooling water system has been designed as a once-through system; the opening of the cooling water intake structure is located at, and the face of the standard 3/8-inch mesh traveling screen is oriented parallel to, the shoreline near the surface of the source waterbody; and the baseline practices, procedures, and structural configuration are those that your facility would maintain in the absence of any structural or operational controls, including flow or velocity reductions, implemented in whole or in part for the purposes of reducing impingement mortality and entrainment.

New York has adopted this baseline definition and endorsed full design flow on 365 days per year as baseline flow [Ref. 6.91]. This section discusses the following existing CWIS technologies and operational measures, previously described in Section 2.4, that differ from the EPA baseline and reduce I&E at the Stations:

- Modified Ristroph-type traveling water screens
- Fish handling and return systems
- Low pressure screenwash systems
- Flow reductions due to dual/variable speed pump operation
- Flow reductions due to maintenance outages

In addition to these existing CWIS technologies and operational measures, Units 2 and 3 also have cooling system designs (i.e., low temperature rise across condensers, rapid transit through cooling system, return of water near point of withdrawal) that permit entrainment survival, as discussed in Attachment 6. Based on the fish survival data provided for the existing Unit 2 and Unit 3 CWISs in Attachment 6, IPEC's existing CWIS technologies and operational measures produce quantifiable reductions from the regulatory baseline I&E, as shown in Section 3.2. Assessments of the qualitative features of each component of the existing CWIS are provided in Section 3.1.

#### **3.1 Description of Existing CWIS Technologies and Current Operational Measures that Affect I&E**

##### **3.1.1 Existing Traveling Water Screens**

As described in Section 2.4.1, the CWISs at Units 2 and 3 have modified vertical Ristroph-type traveling water screens which were installed pursuant to the Hudson River Settlement Agreement [Ref. 6.40]. These screens were installed following a collaborative research effort among the former owners of the Stations and Riverkeeper's predecessor and directed by Dr. Ian Fletcher, then-consultant for Riverkeeper's predecessor. Dr. Fletcher concluded that improvements beyond the screens installed at the Stations were unlikely to



significantly reduce impingement losses and, therefore, the existing screens at the Stations represent the state-of-the-art in terms of minimizing adverse impacts for impingement [Ref. 6.33]. As discussed in Section 2.4.1.1, the traveling water screens at each Unit have the following features:

- Low approach and through-screen velocities – Low through-screen and approach velocities increase the likelihood that fish may escape the intake flow and therefore reduce the potential for impingement [Ref. 6.94]. Refer to Section 2.4.2.4 for a thorough discussion of these velocities.
- Continuous operation – The modified traveling screens are rotated continuously. If accumulation of fish and/or debris on the screens occurs, the same amount of water must pass through a smaller available open area, thus increasing both the through-screen velocity and the differential head loss. As the head losses and velocities increase, it is more likely that fish cannot escape the screen area and become impinged [Ref. 6.94]. Impingement is less likely to occur when the available screen open area is maintained by the continuous removal of fish and/or debris from the screens.
- Flow deflector lip on fish bucket – The curved lip at the leading edge of the fish bucket is designed to minimize vortex stresses on fish inside the buckets. The lip eliminates turbulent flow in the interior of the buckets, allowing fish to maintain a stable, upright position [Ref. 6.35]. Water is also retained by the curved lip, maintaining sufficient water volume for fish in the bucket.
- Spray washes – As noted in Section 2.4.1.2, the screens encounter a series of spray washes in the operating rotation. First, high-pressure sprays remove debris from the screens; spray deflectors prevent disturbance to fish in the fish bucket from these sprays. Then, low-pressure sprays aid in freeing fish from the surfaces of the overturning screen panels by gently spraying water through the screen mesh. Due to the gentle nature of the flow, the low-pressure sprays lose effectiveness when debris covers the screen; the high-pressure sprays must wash off debris first, to ensure effective fish recovery [Ref. 6.35]. Finally, another series of high-pressure screens washes off any remaining debris before the screens rotate back to the intake flow. This final wash reduces ‘carryover’ debris that could potentially enter the pump intakes and assists in maintaining the available open area, which reduces the potential for impingement.
- Smooth screen mesh – The  $\frac{1}{2} \times \frac{1}{4}$ -inch clear opening slot mesh on the screen basket panels is smooth to minimize abrasion to fish transferred into the fish return sluices [Ref. 6.8].

Each of these features contributes to the reductions in impingement losses detailed in Section 3.2. Alternative screening technologies to further reduce I&E are discussed in Section 4.2.

### **3.1.2 Existing Fish Handling and Return System**

Extensive studies, conducted under the oversight of NYSDEC staff and the predecessor to Riverkeeper (HRFA), were performed over several years at the Stations prior to the design and implementation of the current fish return systems. The fish collected in the fish

buckets attached to the traveling water screens are returned to the Hudson River by the fish handling and return system. The low-pressure sprays facilitate the transfer of fish to the fish collection sluices, which deliver fish to return pipes. The Unit 2 return pipe discharges into the Hudson River north of the Stations' CWISs, and the Unit 3 return pipe discharges at the northwest corner of the Stations' combined discharge canal. The discharge locations of the fish return pipes were selected after conducting dye and fish release studies to find locations that would minimize reimpingement [Ref. 6.8]. The design and testing of the fish return systems were conducted under the oversight of HRFA (i.e., Riverkeeper's predecessor) expert, Dr. Ian Fletcher, between 1989 and 1992, with the objective of maximizing fish survival and minimizing reimpingement [Ref. 6.9; Ref. 6.111]. The current fish return systems at Unit 2 and Unit 3 incorporate several features that improve fish survival:

- Removable covers or grates over fish troughs [Ref. 6.54; Ref. 6.55].
- Design water depth maintained at approximately 2 inches [Ref. 6.61].
- Design trough water velocity between 2-5 fps [Ref. 6.9].
- Selection of return pipe discharge locations designed to prevent returned fish from immediately reentering the intake structure [Ref. 6.8].

The fish handling and return systems at IPEC are considered state-of-the-art, and upgrades to the current fish return systems would not be expected to provide appreciable biological benefits.

### **3.1.3 Flow Reductions**

Certain flow reduction strategies offer potential I&E reduction opportunities. The Stations' dual/variable speed pumps allow intake flow to be minimized based on operating requirements. In addition, periods of reduced power at each Unit also contribute to reduced intake flow.

#### **3.1.3.1 Dual/Variable Speed Pumps**

As described in Section 2.4.2.1, Unit 2 is equipped with dual speed CW pumps, and Unit 3 is equipped with variable speed CW pumps. The pumps can be used to minimize the volume of River water drawn through the CWISs, thus minimizing I&E [Ref. 6.89]. Required flow rates are dependent upon intake water temperature, and typically allow reduced flow from late October until early May, not accounting for scheduled outages [Ref. 6.24]. In addition to the ambient River water temperature, flow rates are influenced by plant operating status and SPDES permit conditions.

#### **3.1.3.2 Historic Flow Reductions**

The monthly baseline flows (in millions of gallons per day), and the average monthly historic operational flow provided by the Stations, are shown in Table 3.1 and Table 3.2 below, along with the corresponding flow reduction percentages. As discussed in Section 2.4.2.3.2, the Unit 2 historic flows include CW, SW, and Unit 1 RW flow, and the Unit 3 historic flows include CW and SW flow. Historical data for Station operation and

associated flows for the past eight years (2001-2008) indicate an average historic operational flow reduction of 13.6% for Unit 2 and 28.7% for Unit 3.

Note that, as discussed in Section 2.4.2.3.2, several factors contribute to the differences in Unit 2 and Unit 3 flow rates. First, the SW capacity at Unit 2 (46,000 gpm; Unit 2 SW and Unit 1 RW) is greater than the SW capacity at Unit 3 (36,000 gpm). In addition, the condensers and low pressure turbines at each Unit have different designs, efficiencies, and operational requirements that necessitate substantially different flow requirements. Furthermore, more flow is required to clean the Unit 2 systems due to more debris issues at Unit 2 than at Unit 3.

**Table 3.1 Unit 2 Monthly Flow Reduction from Baseline**

Month	Baseline Flow (MGD)	Historic Operating Flow (MGD)	Average Flow Reduction
January	1275.8	1001.1	21.5%
February	1275.8	924.1	27.6%
March	1275.8	908.4	28.8%
April	1275.8	940.5	26.3%
May	1275.8	1107.5	13.2%
June	1275.8	1243.6	2.5%
July	1275.8	1248.7	2.1%
August	1275.8	1252.3	1.8%
September	1275.8	1253.2	1.8%
October	1275.8	1209.1	5.2%
November	1275.8	1007.8	21.0%
December	1275.8	1115.3	12.6%
Average Annual	1275.8	1102.2	13.6%

**Table 3.2 Unit 3 Monthly Flow Reduction from Baseline**

Month	Baseline Flow (MGD)	Historic Operating Flow (MGD)	Average Flow Reduction
January	1261.4	600.1	52.4%
February	1261.4	583.2	53.8%
March	1261.4	500.9	60.3%
April	1261.4	614.8	51.3%
May	1261.4	899.6	28.7%
June	1261.4	1199.1	4.9%
July	1261.4	1227.1	2.7%
August	1261.4	1217.4	3.5%
September	1261.4	1234.8	2.1%
October	1261.4	1170.1	7.2%
November	1261.4	806.5	36.1%

**Table 3.2 Unit 3 Monthly Flow Reduction from Baseline**

Month	Baseline Flow (MGD)	Historic Operating Flow (MGD)	Average Flow Reduction
December	1261.4	715.2	43.3%
Average Annual	1261.4	899.0	28.7%

### 3.1.3.3 Outage Schedule

As discussed in Section 2.4.2.3, periods of reduced power decrease the actual intake flow entering the Station’s CWISs. This flow reduction represents a reduction from the baseline flow and, where quantifiable and reasonably expected, is considered to be an operational measure to reduce I&E. Outages are scheduled, where reasonably practicable, in a manner sensitive to entrainment considerations, typically during the late spring entrainment period, with the result that only one Unit is operating during that approximately 25 day outage period each year [Ref. 6.24].

## 3.2 Percent Reductions in I&E from Baseline for Existing CWIS Technologies and Current Operational Measures

Based on the data provided in Attachment 6, the Stations’ existing CWIS technologies and operational measures produce quantifiable I&E reductions from the regulatory baseline. As noted in Attachment 6, the regulatory baseline is a regulatory construct that employs certain operation and survival assumptions. This baseline has been used by NYSDEC in SPDES permit proceedings for other New York power plants. The reductions in I&E at the Stations are characterized in terms of equivalent age 1 (EA1) fish rather than as total losses summed over all life stages (as noted in Attachment 6, there are different life stages of fish). The EA1 metric weights losses of different life stages according to their expected survival rates. For example, if only 10% of eggs for a particular species would be expected to die before hatching, then entraining a single larva is equivalent to entraining 10 eggs. If 0.1% of larvae would be expected to survive to become one-year-old fish, then entraining 1000 larvae or 10,000 eggs would be equivalent to removing a single one-year-old fish from the population. Using the EA1 metric to compare technology alternatives ensures that the comparisons weight all life stages equally according to their potential future contributions to the population (see Attachment 6 for further discussion). As shown in Tables 10 and 11 of Attachment 6, Appendix A, the existing CWIS technologies and operational measures at the Stations reduce EA1 entrainment by approximately 33.8%, and reduce EA1 impingement by approximately 80.2% compared to the regulatory baseline. According to Attachment 6, the NYSDEC Proposed Project would reduce EA1 entrainment losses by approximately 96.3 to 97.6% and EA1 impingement losses by approximately 98.9 to 99.3% compared to the regulatory baseline. However, NYSDEC has identified a range of acceptable technology performance, measured in reduced entrainment (more than 60% reduction) and impingement (more than 80% reduction), for other existing New York power stations [Ref. 6.87]. Therefore, consistent with the Stations’ existing technology being considered state-of-the-art for impingement, impingement is limited to NYSDEC acceptable levels. For this reason, this Report primarily focuses on entrainment reductions.

## 4 I&E Reduction Technologies

This section reviews potential alternative technologies and operational measures for reducing I&E associated with the Stations from the regulatory baseline. The evaluation focuses on engineering, biological, and cost factors consistent with the Interim Decision. The engineering factors include technological feasibility and reliability, proven installation at comparable facilities, and nuclear safety concerns, where relevant. If installation of the alternative technology is feasible based on the engineering factors, the evaluation estimates the associated reductions in I&E from the regulatory baseline, as provided in Attachment 6. Technologically feasible means that a particular technology likely can be implemented at comparable steam-electric generating stations and, as qualified, at the Stations to reduce I&E without implicating nuclear safety considerations.

For certain alternative technologies, very preliminary capital and operational costs are estimated using conceptual models appropriate at this stage of the analysis (see Attachment 4). However, costs are likely understated due to unknown site-specific conditions. For this reason, a Recommended Minimum Contingency of 30% was added to all cost estimates [Ref. 6.25; Ref. 6.113]. A typical cost multiplier of 30% was employed to capture both corporate overheads and the cost of carrying the associated funding (i.e., a Corporate Overheads and Work In Progress Cost). In addition, the preliminary estimates provided in this Report do not account for several complicating factors, including radiological contamination, zoning restrictions and archeological considerations in place at IPEC.

Potential modifications to the CWIS for a nuclear facility, such as IPEC, where each Unit's CWIS combines the circulating water and service water intakes, are complicated by the fact that service water flow is related to nuclear safety, and must be available at all times (i.e., for normal operations, shutdown, and projected accident conditions). Therefore, any potential technology that could introduce new failure modes into the service water systems, or that could interfere with maintaining the service water supply, implicates nuclear safety concerns and, therefore, would require further evaluation.

Technological feasibility may be qualified if the technology is unprecedented (i.e., not demonstrated at any comparable facility). In addition, as discussed in Section 3.2 and Section 4.1, the Stations' existing technology is considered state-of-the-art for impingement; this Report primarily focuses on entrainment reductions. As such, technologies that would not provide substantial reductions in entrainment are not considered as viable alternatives to the current intake technologies at the Stations.

### 4.1 Upgrade of the Existing Fish Handling and Return Systems

As discussed below, no improvements to the existing fish handling and return systems are necessary. The main objective of any fish return system is to return impinged fish to the water body with minimal stress. As discussed in Section 3.1.2, fish return designs vary to accommodate the size and type of fish being transported. The Unit 2 and Unit 3 TWSs at the Stations have separate fish return systems that are described in Section 2.4.1.2.

As part of the Hudson River Settlement Agreement, consultation and mutual concurrence among interested environmental parties, including Riverkeeper (then known as the Hudson

River Fisherman's Association), was required for the design of the fish return systems [Ref. 6.9]. Therefore, prior to the installation of the Stations' fish return systems, extensive studies were conducted, and prototype fish return system models were designed. The design and testing of the fish return systems were conducted under the oversight of Dr. Ian Fletcher, biologist for the Hudson River Fishermen's Association (the predecessor to Riverkeeper), between 1989 and 1992 [Ref. 6.9; Ref. 6.111]. Offshore dye studies were conducted to determine the best location for the fish return pipe discharges to limit recirculation, and live fish release studies were performed to determine the optimum discharge depths for the fish return pipes. Design models of the Unit 2 and Unit 3 fish return systems were installed at a nearby quarry and tested. The results of these tests indicated that the full systems would not impose injuries to the test species (white perch, striped bass, golden shiner, and alewife) under expected operating conditions [Ref. 6.9].

Per Siemens Water Technologies (Siemens), an industry leader in the design of fish return systems and traveling water screens, the fish return systems at Units 2 and 3 are considered to be state-of-the-art. Furthermore, Siemens does not recommend any upgrades to the fish return systems that would improve survivability rates (see Attachment 1, Section 1). As discussed in Section 2.4.1.1, in the Fletcher Article [Ref. 6.33], Dr. Fletcher concluded that improvements beyond the screens installed at the Stations were unlikely to significantly reduce impingement losses [Ref. 6.33]. In addition, the Fletcher Article [Ref. 6.33] indicates that the NYSDEC adopted the performance of these screens as the State's best technology available for reducing impingement.

### Conclusions

The Stations' fish return systems at Units 2 and 3 are considered to be state-of-the-art, and Siemens does not recommend any upgrades that would improve survivability rates (see Attachment 1, Section 1). Based on the previous studies performed under the oversight of Dr. Ian Fletcher, the (relative) recent vintage of the fish return systems, and Siemens' review, upgrades to the current fish return systems are not expected to provide appreciable impingement benefits. The system does not impact entrainment.

## **4.2 Traveling Water Screens**

Traveling water screens can be designed with coarse mesh ( $> 2.0$  mm) or fine mesh openings ( $\leq 2.0$  mm) [Ref. 6.115]. Generally, entrainment decreases with smaller mesh sizes, as fine mesh screens impinge organisms that are typically entrained through coarse mesh screens. However, as discussed in Attachment 6, mortality from impingement can offset entrainment reductions, depending on species and life stage of the fish being impinged instead of entrained. Smaller mesh sizes also increase the possibility of significant fouling and heavy debris loading on the screening panels. Mortality of early life stage organisms impinged on fine mesh screens can increase due to stresses caused by the resultant higher debris loads, increased through-screen velocities, and increased pressure differentials.

In certain circumstances, traveling screens, such as through flow, dual flow, and center flow screens, can be fitted with fine mesh screen material. Where entrainment is a seasonal occurrence, existing traveling water screens can be retrofitted with interchangeable fine mesh panels or fine mesh inserts laid over and fastened to the permanent coarse mesh screens for

seasonal operating requirements (e.g., a facility could replace the coarse mesh or install fine mesh inserts during the entrainment season to reduce the entrainment of eggs) [Ref. 6.115].

The following sections evaluate alternative screening technologies to the existing coarse mesh Ristroph screens. A mesh opening size of 2.0 mm was selected for the conceptual designs of fine mesh screening systems to provide a consistent comparison between technologies. This opening size was chosen as it is the smallest opening size that would likely provide reliable flow and avoid screen failures due to excessive debris loading and/or fouling. The biological information provided in Attachment 6 determines the potential reductions in EA1 I&E from the regulatory baseline for select opening sizes (i.e., 9.0, 6.0, 3.0, 2.0, 1.5, and 1.0 mm).

#### 4.2.1 Alternative Ristroph Screens

Alternative Ristroph screens (i.e., Ristroph screens with different mesh opening sizes than the mesh opening size of the existing Ristroph-type TWSs) are not considered as viable alternatives to the current screening systems at the Stations. As shown in Attachment 6, the use of alternative Ristroph screens (coarse or fine mesh) would not be expected to provide substantial reductions in EA1 I&E from the existing TWSs and fish return systems, because the maximum possible reduction in EA1 entrainment losses achievable by fine mesh Ristroph screens (34.9%) is only 1.1% more than the current reduction in EA1 entrainment losses (33.8%), as shown in Section 3.2. Moreover, significant civil/structural modifications would be required to install fine mesh Ristroph screens at the Stations.

The primary concern with fine mesh screens is that they can impinge early organism life stages that are entrained through coarse mesh screens. Depending on species and life stage, mortality from impingement can exceed entrainment mortality. In order for fine mesh screens to reduce entrainment losses, impingement survival of target species previously entrained must be substantially greater than entrainment survival through the circulating water system. In addition, smaller mesh sizes (i.e., < 2.0 mm) would create significant opportunity for fouling and heavy debris loading of the screen panels with a corresponding effect on survival. A study of 0.5 mm fine mesh TWSs installed at the Prairie Island Nuclear Generating Plant, located on the Mississippi River in Red Wing, Minnesota, concluded that debris volume had a significant effect on survival with mortality of all early life stages between 95 - 100% during high debris loads [Ref. 6.32]. Where debris loading is persistent, survival can be significantly impacted.

The Consolidated Edison Company of New York (ConEd, predecessor of Entergy) commissioned reviews of previous fine mesh studies, surveys of existing fine mesh applications, and model flume trials of a fine mesh Ristroph screen between 1990 and 1991 [Ref. 6.34; Ref. 6.32]. A field study of a fine mesh Ristroph screen installed at Unit 1 concluded that there is no net gain when mortalities of entrained organisms are no greater than the mortalities imposed on the same organisms by impingement on fine mesh screens [Ref. 6.31]. In 1994, Dr. Ian Fletcher concluded that mesh sizes smaller than 3 mm could not be safely recommended due to operational/reliability issues with the fine mesh panels including tears, punctures, and detachment from the screen frames [Ref. 6.32].

Brunswick Nuclear Plant (BNP), which receives cooling water from the Cape Fear River near Southport, North Carolina, utilizes 1.0 mm fine mesh panels that are placed on top of

the permanent 9.5 mm (3/8 inch) TWS panels during periods of high entrainment to filter a maximum cooling water intake capacity of 1,328,000 gpm [Ref. 6.7; Ref. 6.115]. An 84% reduction in entrainment (compared to the permanent screen systems) was reported at BNP following the installation of the fine mesh inserts [Ref. 6.115]. Although EPA references the BNP as a successful application of fine mesh screens [Ref. 6.115], application of these screens at BNP has been limited. As stated in the BNP 2000 Environmental Monitoring Report [Ref. 6.6], “[d]uring periods of high vulnerability resulting from extreme lunar tides or increased sediment and debris loading, the [National Pollutant Discharge Elimination System] NPDES permit allows for removal of a portion of the fine-mesh screens to prevent plant scrams. High vulnerability conditions existed for most of the year.” Impingement survival of organisms that formally would have been entrained was not determined.

Although seasonal deployment of fine mesh inserts on top of the coarse mesh TWS panels during periods of high entrainment could provide entrainment reductions at some facilities, fine mesh screens inserted on permanent coarse mesh screens can increase flow resistance or head loss. For a 1.0 mm mesh panel installed over a  $\frac{3}{8}$  inch coarse metal panel, the head loss at a through-screen velocity of 1.0 fps increases by a factor of 3.8. For a 0.5 mm mesh on  $\frac{3}{8}$  inch coarse metal panel, the head loss at a through-screen velocity of 1.0 fps increases by a factor of 4.8 [Ref. 6.34]. Increases in head loss across the screening panels present numerous mechanical and biological issues. The primary mechanical concern is that the rate of debris plugging or blinding of the screening mesh is increased dramatically due to the increased pressure differentials combined with the smaller sizes of debris impinged by fine mesh screens [Ref. 6.27]. Increased pressure differentials can cause smaller impinged organisms to be damaged by extrusion (i.e., the organisms are compressed and forced through the screening mesh). The increased debris loads also add weight to the TWS panels causing premature wear and failure of bearings, chains, and sprockets. Permanently installed fine mesh screens typically experience tearing of the mesh material from the panel frames caused by metal fatigue due to the flexing of the panels during their ascent and descent in the water column [Ref. 6.34]. These mechanical issues contribute to substantial increases in maintenance requirements and repair/replacement costs. In addition, due to the increased pressure differentials, increased vortexing in the Ristroph buckets can occur, causing stresses on impinged fish resulting in mortality [Ref. 6.27].

According to 40 CFR §125.94, if a facility reduces the through-screen velocity to at or below 0.5 fps, it is “deemed to have met the impingement mortality performance standards”. In order to maintain existing head loss across the screen and provide a through-screen velocity at or below 0.5 fps, the size of the CWISs would need to be expanded to accommodate fine mesh Ristroph screens. A much larger fine mesh screen area would be required to provide the same total open area as a coarse mesh screen. Four 2.0 mm fine mesh traveling water screens would be required per intake channel to filter the required flow and provide a through-screen velocity at or below 0.5 fps.

Attachment 2, Figures 2-1 through 2-3 depict a conceptual design for 2.0 mm fine mesh Ristroph screens at Units 2 and 3. The conceptual designs would require expansion of the existing intake structures to form new forebays. Each forebay would be dedicated to an existing CW intake channel and would house four 2.0 mm fine mesh TWSs near its face. Each 2.0 mm fine mesh TWS channel would be equipped with new bar racks and stop logs



providing large debris removal and isolation of the fine mesh TWSs for repair or maintenance. The expanded intake for fine mesh TWSs shown in Attachment 2 would not affect the existing operation of the SW intake channels, and would include a new or modified fish return system that would be required for removal of organisms and debris from the TWSs. As shown, significant civil/structural modifications would be required to install fine mesh TWSs at the Stations.

#### Maintenance

The maintenance activities required for 2.0 mm fine mesh Ristroph screens would be similar to the current maintenance operations associated with the existing coarse mesh Ristroph screens, but maintenance frequency would likely increase. Due to the larger debris loads retained by fine mesh screens, however, wear on mechanical components would be expected to be greater, thus requiring a higher frequency of maintenance and replacement compared to the existing TWSs. As such, the overall maintenance costs and time would be expected to increase significantly for fine mesh Ristroph screens compared to the current coarse mesh Ristroph screens due to the increased debris loads and larger number of Ristroph screens required. At a minimum, maintenance costs required for fine mesh TWSs would be at least 4 times the costs required to maintain the existing coarse mesh TWSs.

Because fine mesh screens are more susceptible to biofouling than coarse mesh screens, it is likely that a sodium hypochlorite system would be required to periodically dispense sodium hypochlorite in front of any fine mesh Ristroph screens to provide biofouling control. Any addition of sodium hypochlorite to the CW systems would need to be evaluated for potential impacts to the SPDES permit [Ref. 6.86].

#### Cost

The total estimated capital cost for Unit 2 and Unit 3 for the installation of the 2.0 mm fine mesh Ristroph screens, as shown in Attachment 2 Figures 2-1 through 2-3, would be approximately \$373 million (see Attachment 4).

The construction activities associated with expanding the existing Unit 2 and Unit 3 intake structures and the installation of 2.0 mm fine mesh Ristroph screens would take approximately six to nine months per Unit. As discussed in Section 2.4.2.3.1, refueling outages are anticipated to last approximately 25 days. Assuming that the construction activities could be scheduled to coincide with a routine maintenance outage for each Unit, there would be approximately five to eight months of lost generating capacity per Unit during the implementation of the evaluated 2.0 mm fine mesh Ristroph screens. As discussed in Section 2.1, the Stations currently generate electricity at a rated capacity of approximately 1078 MWe and 1080 MWe for Units 2 and 3, respectively. A five to eight month construction outage would result in a loss of approximately 3.9 million to 6.3 million MW-hrs per Unit. If construction activities could not be scheduled to coincide with a routine maintenance outage, the costs due to construction outages would increase.

#### I&E Discussion

Attachment 6 (Tables 17 and 23 of Appendix A) provides the reductions from the regulatory baseline in EA1 losses averaged among species and years that could be

achieved using 9.0, 6.0, 3.0, 2.0, 1.5, and 1.0 mm Ristroph screens accounting for the Stations' survival rates (Attachment 6) and average historic flow reductions (Section 2.4.2.3.2). A summary of the information included in Attachment 6 is shown in Table 4.1.

**Table 4.1 Potential Percent Reduction of Annual EA1 I&E Losses due to Modified Ristroph Screens in Each Month**

Month	EA1 Entrainment Loss Reduction						EA1 Impingement Loss Reduction
	9.0 mm	6.0 mm	3.0 mm	2.0 mm	1.5 mm	1.0 mm	
January	0.0%	0.0%	0.0%	0.0%	0.0%	0.0%	8.7%
February	0.0%	0.0%	0.0%	0.0%	0.0%	0.0%	9.6%
March	0.0%	0.0%	0.0%	0.0%	0.0%	0.0%	12.0%
April	0.3%	0.4%	0.4%	0.4%	0.4%	0.4%	6.6%
May	5.9%	6.1%	6.2%	6.1%	5.9%	4.8%	7.4%
June	13.6%	14.3%	14.1%	12.8%	11.0%	8.7%	8.5%
July	5.8%	6.4%	7.0%	7.0%	6.9%	6.9%	4.0%
August	3.4%	4.1%	4.8%	4.8%	4.8%	4.8%	4.2%
September	1.3%	1.3%	1.5%	1.5%	1.5%	1.5%	4.4%
October	1.2%	1.1%	1.0%	1.0%	1.0%	1.0%	3.8%
November	0.0%	0.0%	0.0%	0.0%	0.0%	0.0%	4.6%
December	0.0%	0.0%	0.0%	0.0%	0.0%	0.0%	6.3%
Annual	31.5%	33.8%	34.9%	33.5%	31.5%	27.9%	80.2%

The maximum possible reduction in EA1 entrainment losses shown in Table 4.1 (34.9%) is only 1.1% more than the current entrainment reduction (33.8%) shown in Section 3.2. Additionally, the estimated reduction in impingement provided by alternative Ristroph screens, regardless of mesh size, is identical to the current reductions provided by the existing Ristroph-type TWSs.

### Conclusions

The estimated initial costs associated with the conceptual installation of the 2.0 mm fine mesh Ristroph screens would include approximately \$373 million in capital costs and approximately 3.9 million to 6.3 million MW-hrs of lost generation due to the required construction outages. As shown in Table 4.1, none of the mesh sizes evaluated would be expected to reduce EA1 entrainment losses from baseline by more than approximately 34.9%, and, therefore, would be essentially similar to current technology conditions (Section 3.2). As such, alternative Ristroph screens are not further considered to be viable alternatives to the existing intake technologies.

### 4.2.2 Dual Flow Traveling Water Screens

Dual flow traveling water screens are not considered as viable alternatives to the current screening systems at the Stations, because the use of dual flow traveling water screens (coarse or fine mesh) would not be expected to provide substantial reductions in EA1 I&E from the existing TWSs and fish return systems.

In order to reduce the through-screen velocities by increasing the available screen area, and thus potentially reduce impingement, the existing through flow traveling water screen installations at many facilities can be retrofitted to use dual flow traveling water screens [Ref. 6.94]. As discussed in Section 4.2.1, if a facility could reduce its maximum through-screen velocity to at or below 0.5 fps, impingement is considered to be reduced to acceptable levels, according to EPA. In addition, according to the Hudson River Power Plants Final Environmental Impact Statement [Ref. 6.88], NYSDEC has indicated interest in through-slot velocities of 0.25 fps. As shown in Figure 4.1, dual flow traveling water screens are mechanically similar to through flow screens but are rotated ninety degrees within the flow channel, which reduces the through-screen velocity by increasing the surface area and eliminating the potential for carryover.

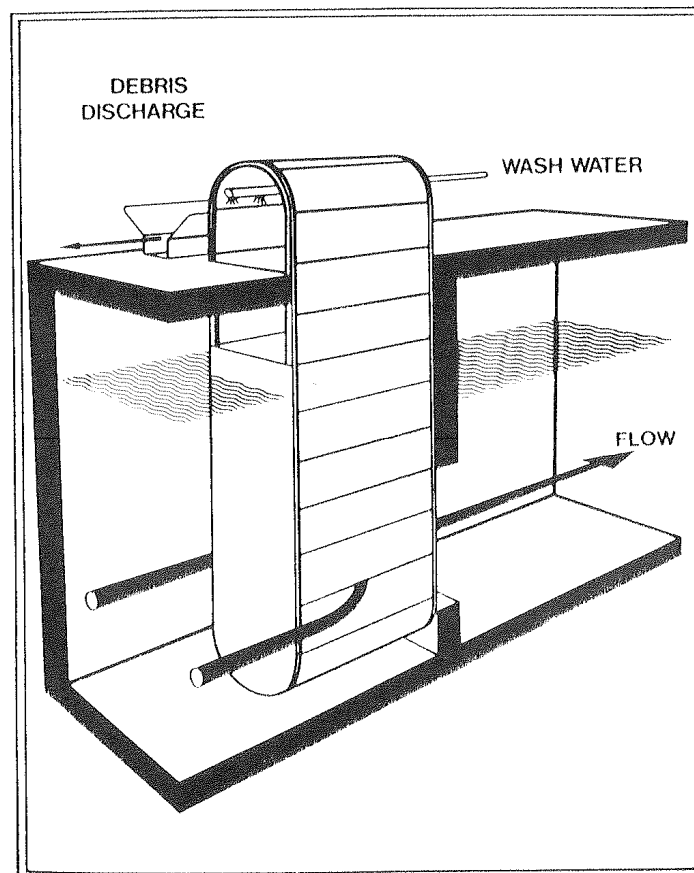

**Figure 4.1 Typical Dual Flow Screen Arrangement [Ref. 6.94]**

The orientation of a dual flow screen allows the entire submerged screen surface to be an active screen area. Thus, for an identical basket width, a dual flow screen can filter twice the volume of water as a through flow screen. If the volume of water to be filtered is constant and the traveling screens have identical basket widths, the through screen velocity of a dual flow screen will be approximately half of the through screen velocity of a through flow screen. Unlike through flow screens, the configuration of dual flow traveling water screens (parallel to the direction of incoming flow) eliminates debris carryover to the condensers and reduces condenser maintenance because the screening face of the baskets

are not rotated into the downstream flow of the intake. Figure 4.2 compares the flow pattern through a through flow traveling water screen with the flow pattern through a dual flow traveling water screen.

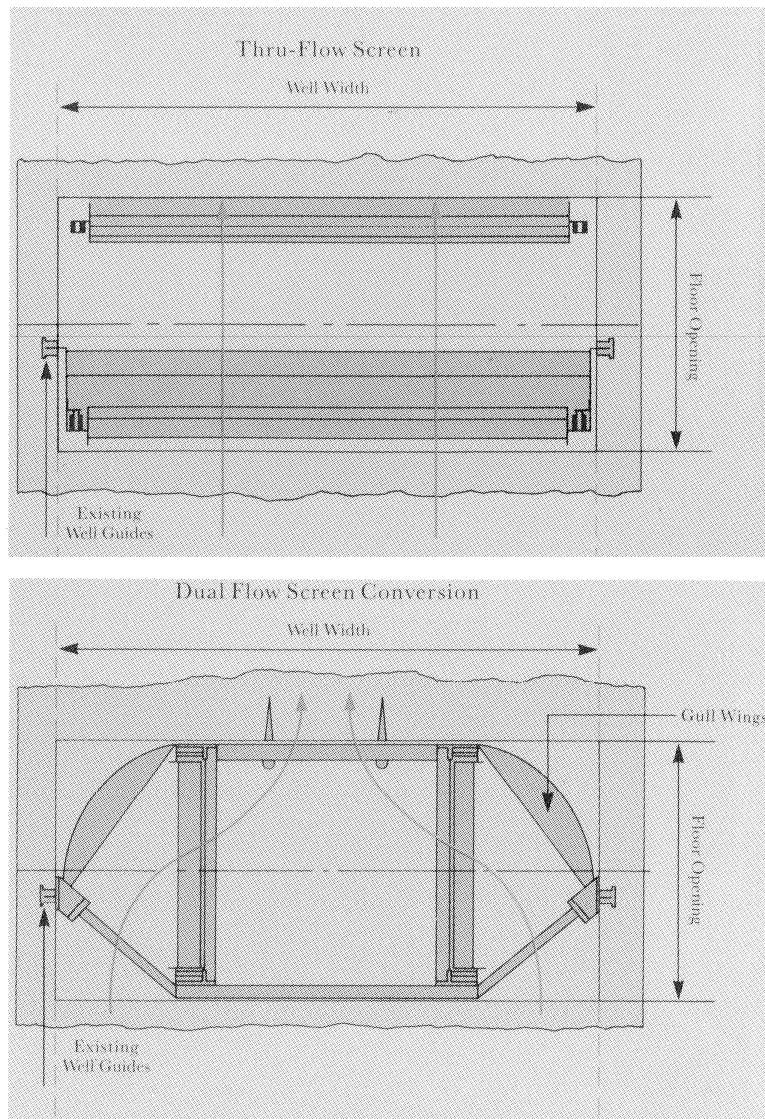

**Figure 4.2 Plan View of Through Flow to Dual Flow Retrofit [Ref. 6.94]**

Conversion from through flow to dual flow traveling water screens typically includes the installation of a special wall plate mounted perpendicular to the flow in place of the existing screen. The dual flow screen is then lowered into the channel, with baskets parallel to the flow, on the upstream side of the wall plate. An inlet opening in the wall plate allows screened water to flow to the pumps. An alternative arrangement uses a specially constructed screen mainframe that includes a wall plate made as an integral part of the screen frame with extensions or “wings” that fit into existing embedded guides. Dual flow traveling water screens have been retrofitted at nuclear power generating facilities, including Cooper Nuclear Station located on the Missouri River. In 2006, coarse mesh dual flow traveling water screens were retrofitted at Cooper Nuclear Station to

address debris carry-over problems encountered with the original through flow traveling water screens [Ref. 6.83]. Each dual flow screen is equipped with fish collection baskets and is designed to filter a maximum flow rate of 159,000 gpm with a through screen velocity of approximately 2.0 fps [Ref. 6.83].

Fine mesh dual flow screens have been in operation since 1984 at Unit 4 of the coal-fired TECO Big Bend Power Station located on the Tampa Bay estuary across from Tampa, Florida. The six dual flow screens have a 0.5 mm mesh size and filter an intake flow of approximately 483,435 gpm. Biofouling control was a significant issue at TECO Big Bend Power Plant requiring biweekly manual cleaning of the dual flow screens by a two person crew [Ref. 6.14].

Retrofitting the Stations' CWISs with coarse mesh dual flow traveling water screens (i.e., ¼-inch by ½-inch basket mesh openings) would only reduce the through-screen velocity (calculated in Section 2.4.2.4) to approximately 0.81 fps. Therefore, in order to accommodate fine mesh dual flow screens while maintaining the existing head loss across the screens and providing a through-screen velocity at or below 0.5 fps, the size of the CWISs would need to be expanded to accommodate fine mesh dual flow screens. Attachment 2, Figures 2-4 through 2-6 depict a conceptual design for 2.0 mm dual flow screens at Units 2 and 3. A new intake forebay would be dedicated to each existing CW intake channel and would house three 2.0 mm dual flow screens near its face. Per EIMCO Water Technologies (EWT), a leading manufacturer of dual flow screens, three 2.0 mm dual flow screens would be required to filter the intake water flows while maintaining a through-screen velocity at or below 0.5 fps (see Attachment 1, Section 2). The face of the expanded intake would be located between 90 and 170 ft from the face of the existing intake structure and would have a width of nearly 200 ft. New bar racks and stop logs would be installed to provide large debris removal and isolation of the screens for repair or maintenance. This conceptual design would not affect the existing operation of the SW intake channels, and would include new or modified fish return systems that would be required to safely return impinged organisms to the source water body. As shown, significant civil/structural modifications would be required to install fine mesh dual flow screens at the Stations.

### Maintenance

The maintenance activities required for dual flow screens would be expected to be similar to the current maintenance operations associated with the existing coarse mesh TWSs, although overall maintenance costs and time would be expected to increase significantly for fine mesh dual flow screens. At a minimum, maintenance costs required for 2.0 mm fine mesh dual flow TWSs would be expected to be at least three times the costs required to maintain the existing coarse mesh TWSs. However, because dual flow screens virtually eliminate debris carryover into the condenser, there would be reduced maintenance associated with cleaning the condenser.

Because fine mesh screens are more susceptible to biofouling than coarse mesh screens, it is likely that a sodium hypochlorite system would be required to periodically dispense sodium hypochlorite in front of any fine mesh dual flow screens to provide biofouling control. Any addition of sodium hypochlorite to the CW systems would need to be evaluated for potential impacts to the SPDES permit [Ref. 6.86].

### Cost

The total estimated capital cost for Unit 2 and Unit 3 for the conceptual installation of the 2.0 mm dual flow screens, as shown in Attachment 2 Figures 2-4 through 2-6, would be approximately \$350 million (see Attachment 4).

The construction activities associated with expanding the existing Unit 2 and Unit 3 intake structures and the installation of 2.0 mm fine mesh dual flow screens would take approximately six to nine months per Unit. As discussed in Section 2.4.2.3.1, refueling outages are anticipated to last approximately 25 days. Assuming that the construction activities could be scheduled to coincide with a routine maintenance outage for each Unit, there would be approximately five to eight months of lost generating capacity per Unit during the implementation of the evaluated fine mesh dual flow screens. As discussed in Section 2.1, the Stations currently generate electricity at a rated capacity of approximately 1078 MWe and 1080 MWe for Units 2 and 3, respectively. A five to eight month construction outage would result in a loss of approximately 4.7 million to 6.3 million MW-hrs per Unit. If construction activities could not be scheduled to coincide with each Unit's routine maintenance outages, the costs due to construction outages would increase.

### I&E Discussion

Any incremental impingement reductions provided by dual flow screens would not be expected to be appreciable, because the Stations' existing TWSs screens and fish return systems already provide state-of-the-art impingement protection (Section 3.2). Attachment 6 (Table 17 of Appendix A) provides the expected reductions in EA1 entrainment losses from baseline that could be achieved through the installation of fine mesh panels with various mesh sizes (summarized in Table 4.1). However, as discussed in Section 4.2.1, the maximum possible reduction in EA1 entrainment losses shown in Table 4.1 (34.9%) is only 1.1% more than the current entrainment reduction (33.8%).

### Conclusions

The estimated initial costs associated with the conceptual installation of the 2.0 mm fine mesh dual flow screens would include approximately \$350 million in capital costs and 4.7 million to 6.3 million MW-hrs of lost generation due to the required construction outages. Dual flow screens would not be expected to provide substantial reductions in EA1 I&E from the existing TWSs and fish return systems. Therefore, dual flow screens are not further considered as an alternative to the current screening systems.

## **4.2.3 Angled Traveling Screens**

Angled traveling screens are not considered to be viable alternatives to the current screening systems at the Stations, because the use of angled traveling screens (coarse or fine mesh) would not be expected to provide substantial reductions in EA1 I&E from the existing TWSs and fish return systems.

Angled traveling screens typically consist of through flow traveling screens set at an angle to the incoming flow. Angled traveling screens cause abrupt changes in the velocity and direction of the flow, creating a turbulence zone in front of the screens that fish typically avoid. Rather, fish tend to align themselves parallel to the incoming flow, coming in

contact tail first with the turbulence zone. As shown in Figure 4.3, fish move away from the turbulence zone in a direction perpendicular to the angled traveling screens. The net effect of this behavioral response, after repeated excursions away from the turbulence zone, is a lateral displacement of fish towards the end of the angled traveling screens into a bypass channel that returns fish to the source waterbody [Ref. 6.35].

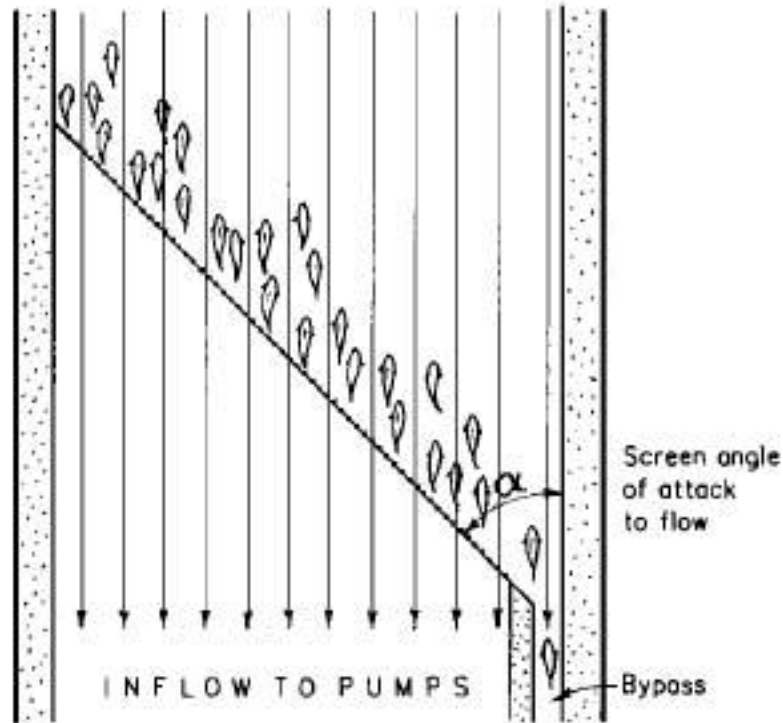

**Figure 4.3 Angled Traveling Screen Guiding Fish Towards Bypass Channel [Ref. 6.35]**

Modular inclined screens (MISs) are a specific variation of angled traveling screens, where each module consists of integrated bar racks, dewatering stop logs, inclined screens set at a  $10^\circ$  to  $20^\circ$  angle to the incoming flow, and a bypass channel to return fish to the source water body. A plan view of MISs is shown in Figure 4.4.

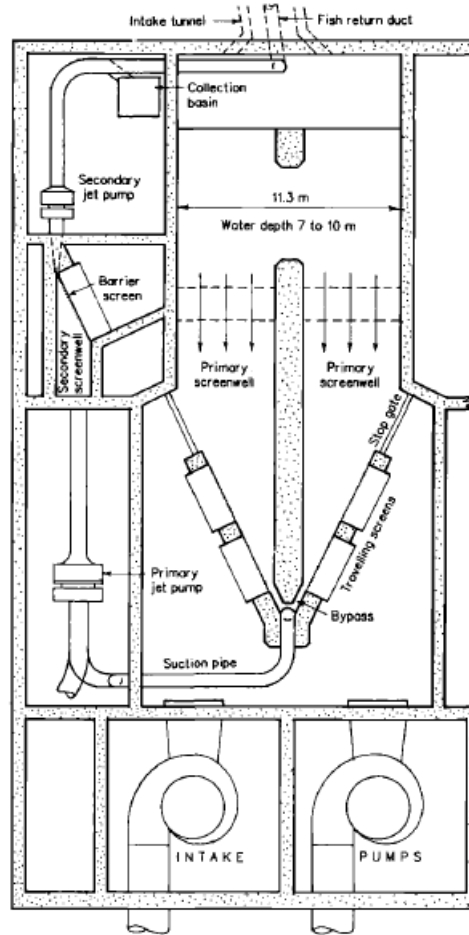

**Figure 4.4 Plan View of MISs [Ref. 6.35]**

In order to maintain existing head loss across the screen panels and provide a through-screen velocity at or below 0.5 fps, the size of the CWISs would need to be expanded to accommodate fine mesh angled traveling screens. As previously determined in Section 4.2.1, four 2.0 mm fine mesh TWSs with a wire thickness of 0.5 mm would be required per intake channel to filter the required flow while maintaining a through-screen velocity at or below 0.5 fps.

A conceptual design for angled traveling screens at the Stations would be similar to the conceptual configurations for fine mesh dual flow and fine mesh Ristroph screens shown in Attachment 2. However, the width of the expanded intake required for angled traveling screens would be larger because each angled traveling screen channel would include a fish bypass channel. The width of the expanded intake for 2.0 mm fine mesh angled traveling screens providing screened cooling water to three CW channels would be approximately 238 ft wide assuming a 1 ft wide fish bypass channel and 3 ft thick walls. Each fine mesh angled traveling screen would be paired with new bar racks and stop logs providing large debris removal and isolation of the traveling screens for repair or maintenance. Due to the fish bypass channels and pumps required to induce flow in the bypass channel, implementation of fine mesh angled traveling screens would require more civil/structural



and mechanical modifications than the implementation of fine mesh dual flow screens or fine mesh Ristroph screens.

#### Maintenance

The maintenance activities required for angled traveling screens are expected to be similar to the current maintenance operations associated with the existing coarse mesh TWSs, although additional maintenance for the new pumps required to induce flow in the bypass channels would be required. Overall maintenance costs and time would be expected to increase significantly for fine mesh angled traveling screens compared to the current coarse mesh TWSs due to the larger number of fine mesh screens required and the addition of circulating pumps for the fish bypass channels. The use of fine mesh screens would create larger debris loads; therefore, additional wear on mechanical components would be expected, resulting in a higher frequency of maintenance and replacement compared to the existing TWSs. Due to the increased number of screens required for the implementation of fine mesh angled traveling screens, maintenance costs would be expected to be approximately four to five times the costs required to maintain the existing coarse mesh TWSs.

Additionally, because fine mesh screens are more susceptible to biofouling than coarse mesh screens, it is likely that a sodium hypochlorite system would be required to periodically dispense sodium hypochlorite in front of any fine mesh angled traveling screens to provide biofouling control. Any addition of sodium hypochlorite to the CW systems would need to be evaluated for potential impacts to the SPDES permit [Ref. 6.86].

#### Cost

The conceptual installation of fine mesh angled traveling screens would require more civil/structural and mechanical work than the conceptual installation of fine mesh dual flow or Ristroph screens. Therefore, the estimated capital costs for the conceptual installation of 2.0 mm fine mesh angled traveling screens would be anticipated to be significantly higher than the estimated costs for installation of 2.0 mm fine mesh dual flow screens (Section 4.2.2) or 2.0 mm fine mesh Ristroph screens (Section 4.2.1).

#### I&E Discussion

With respect to impingement, in a scaled hydraulic study of the biological effectiveness of a MIS system (i.e., an angled screen system including a bypass channel to return fish to the source waterbody), the Electric Power Research Institute (EPRI) concluded MIS systems have potential to safely and effectively divert juvenile fish at CWISs [Ref. 6.13]. Diversion efficiency is defined as the ratio of fish diverted into a bypass channel divided by the sum of fish diverted and fish impinged against the angled screens. In a full scale study of an MIS system installed at the oil- and gas-fired Oswego Power Generating Station on Lake Ontario, diversion efficiencies of 91% for alewives, 92% for rainbow smelt, and 93% for white perch were reported [Ref. 6.35]. However, data collected during the full scale study from the bypassed fish determined that 86% of the bypassed alewives were dead or injured on arrival in the collection basin. The corresponding immediate mortalities for rainbow smelt were 59%, and for the white perch 80% [Ref. 6.35]. In addition, any impingement reductions provided by angled traveling screens would not be

expected to be appreciable when compared to the impingement reductions associated with the Stations' existing TWSs screens and fish return systems (Section 3.2).

Entrainment reductions would not be appreciable. As discussed in Attachment 6, in order to avoid entrainment, larvae have limited capabilities to move into a sweeping flow that bypasses a screen. However, due to the configuration of the angled traveling screens inside a CWIS, no sweeping flow bypassing the screen would be present. Therefore, because eggs and larvae cannot swim away from the turbulence created by angled traveling screens, there is no substantial reduction in entrainment [Ref. 6.107]. As such, angled traveling screens are not expected to improve reductions in EA1 entrainment losses compared to Ristroph screens (see Table 4.1).

### Conclusion

Angled traveling screens would not be expected to provide substantial reductions in EA1 I&E from the existing TWSs and fish return systems. Moreover, the capital costs and maintenance costs associated with angled traveling screens would be significantly higher than the costs associated with dual flow screens or Ristroph screens due to additional civil/structural and mechanical work associated with the installation of the fish bypass channels and their flow-inducing pumps. Therefore, angled traveling screens are not further considered as an alternative to the current screening systems.

## **4.2.4 WIP Screens**

Beaudrey USA W Intake Protection (WIP) screens are not considered as viable alternatives to the current screening systems at the Stations, because the use of WIP screens (coarse or fine mesh) would not be expected to substantial reductions in EA1 I&E from the existing TWSs and fish return systems.

The WIP screen is a modified revolving disc screen that may often be retrofitted into intakes that currently have through flow TWSs. The traditional revolving disc screen consists of a flat disc covered with screening material that rotates about a horizontal axis perpendicular to the water flowing into an intake. As water flows through the submerged portion of the disc, solids are retained on the screening media. On a traditional revolving disc screen, the rotation of the disc lifts the solids above the water surface where they are removed by spray nozzles.

The WIP system consists of one rotating wheel, which rotates within a frame at 1 or 2 revolutions per minute and a fish protection system. Both fish and debris are removed from the screen surface below the waterline by a fish pump and suction scoop. The aquatic organisms do not leave the water and are returned downstream of the intake structure. However, compared to traditional through flow traveling water screens, the WIP system does not utilize the entire available screen area, as shown in Figure 4.5.

With traditional through flow traveling water screens, any fish and/or debris that are not washed off the screen basket would be washed off into the flow of water and carried through the cooling water system. The potential for debris carryover is eliminated as shown in Figure 4.6, because WIP screens do not rotate over into the downstream flow, and all flow must pass through the screen before entering the screenwell and ultimately the condenser.

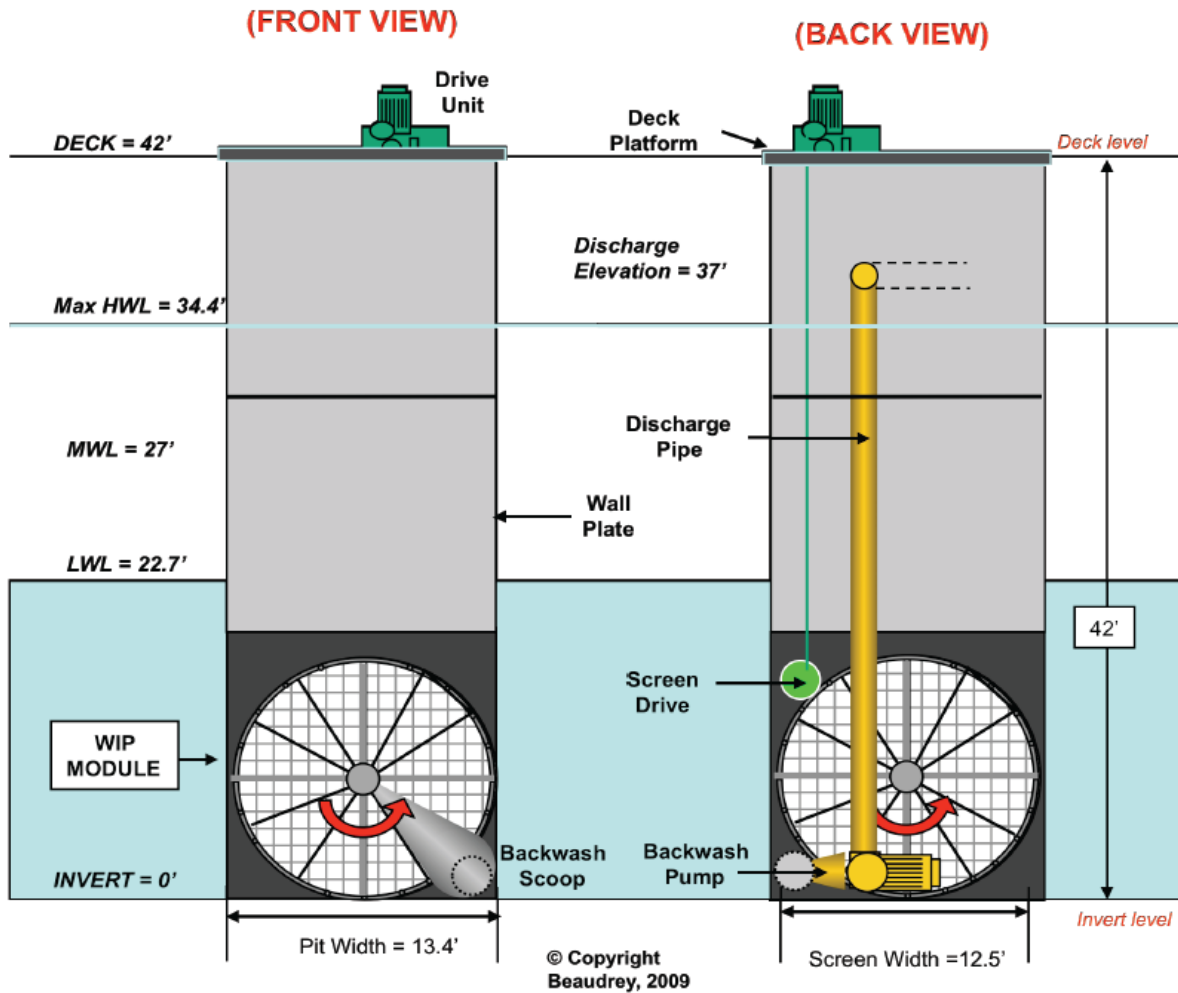

**Figure 4.5 Beaudrey WIP System**

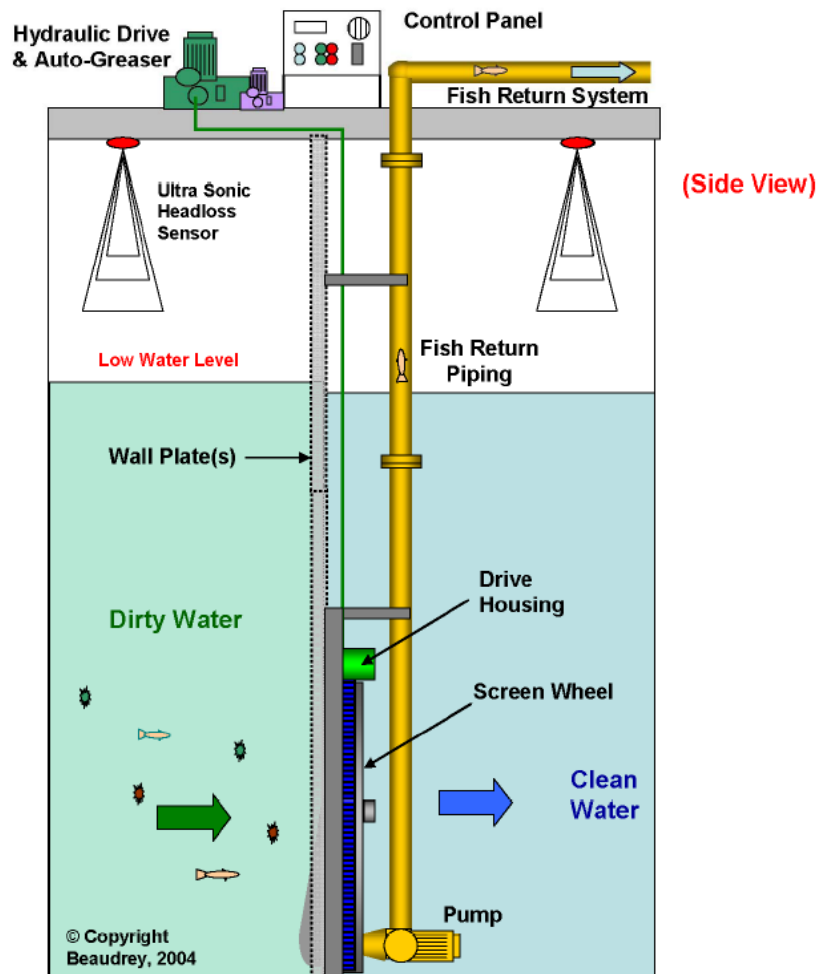

**Figure 4.6 Beaudrey WIP System, Side View**

The WIP System should have appreciably easier maintenance than the existing TWSs, because the WIP screens can be raised out of the water for maintenance activities, do not contain chainbelts or links, and lack spray nozzles and headers. The WIP screens would also eliminate debris carryover into the condensers, reducing maintenance associated with condenser fouling.

WIP screens can also be constructed with a circular fine-mesh screen designed to collect fish eggs and larvae and return them to the source waterbody. However, unlike Ristroph screens or dual flow screens, WIP Systems are not designed to have removable fine mesh inserts, eliminating the possibility of seasonal deployment during periods of high entrainment.

As discussed in Section 2.4.2.4, the existing TWSs allow 140,000 gpm or 143,200 gpm of water to flow through an area defined by the current TWS basket width and the height of the water level, resulting in a maximum through-screen velocity of approximately 1.61 fps or 1.64 fps, respectively. However, as shown in Figure 4.5, a WIP system would limit the flow area to a circular screen section and would require the same volume of flow to pass through a smaller area, resulting in an increased through-screen velocity. The through-

screen velocity of a WIP System can be calculated by replacing the basket width and mean low water terms in the through-screen velocity equation provided in Section 2.4.2 with the surface area of the screening wheel. A WIP screen designed to fit into the existing traveling water screen guides would have a width of 13ft 4 inches and would have a 12.5 ft diameter circular screen section. If the circular screen section were constructed of the same wire gauge and opening size as the current TWSs (14 gauge wire and a mesh opening size of  $\frac{1}{2} \times \frac{1}{4}$ -inches), the through-screen velocity would be approximately 4.08 fps at a flow rate of 140,000 gpm, which is 2.5 times greater than the through-screen velocity of the currently installed TWSs.

In order to provide a through-screen velocity at or below 0.5 fps, the size of the CWISs would need to be greatly expanded to accommodate extra WIP screens at the Stations. The number of fine mesh WIP screen screens required to maintain a through-screen velocity at or below 0.5 fps can be determined by replacing the basket width and mean low water terms in the equation previously referenced in Section 2.4.2.4 with the surface area of WIP screening wheel. Ten 2.0 mm fine mesh WIP screens with 12.5 ft diameter screening wheels would be required per intake channel (140,000 or 143,200 gpm) to maintain a through-screen velocity at or below 0.5 fps.

A conceptual design for 2.0 mm fine mesh WIP screens at IPEC would be similar to the conceptual configuration for fine mesh dual flow and fine mesh Ristroph screens shown in Figures 2-4 through 2-6 and Figures 2-1 through 2-3 of Attachment 2, respectively. However, the size of the expanded intake required would be significantly larger, because each of the new dedicated forebays would contain 10 fine mesh WIP screens. The width of the expanded intake for fine mesh WIP screens providing screened cooling water to three CW channels would be approximately 500 ft wide assuming 13 ft 4 inch wide WIP screen channels and 3 ft thick walls. Each fine mesh WIP screen would be paired with new bar racks and stop logs providing large debris removal and isolation of the traveling screens for repair or maintenance. Due to size of the expanded intake required, implementation of fine mesh WIP screens would require more civil/structural and mechanical modifications than the implementation of fine mesh dual flow screens or fine mesh Ristroph screens.

### Maintenance

The WIP screens should have appreciably easier maintenance than the existing TWSs because the WIP screens can be raised out of the water for maintenance purposes. In addition, WIP screens would eliminate debris carryover into the condensers reducing maintenance costs associated with the condensers. However, overall maintenance costs would be expected to increase significantly for WIP screens compared to the current TWSs, due to the number of WIP screens that would be required to screen the normal intake flows of Units 2 and 3 (120 total 2.0 mm fine mesh WIP screens). Due to the increased number of screens required for the implementation of fine mesh WIP screens, maintenance costs required for 2.0 mm fine mesh WIP screens would be expected to be approximately ten times the costs required to maintain the existing coarse mesh TWSs.

Because fine mesh screens are more susceptible to biofouling than coarse mesh screens, it is likely that a sodium hypochlorite system would be required to periodically dispense sodium hypochlorite in front of any fine mesh WIP screens to provide biofouling control.

Any addition of sodium hypochlorite to the CW systems would need to be evaluated for potential impacts to the SPDES permit [Ref. 6.86].

#### Cost

The estimated cost for the WIP System components (i.e., screens, pumps, and controllers) is 3.3 times the cost of the fine mesh Ristroph screen components and 3.7 times the cost of the fine mesh dual flow screen components (see Attachment 1, Section 3). In addition, due to the larger number of fine mesh WIP screens required and the increased costs associated with construction of the expanded intake structures that would be required to house the larger number of screens, the estimated capital costs for the installation of conceptual 2.0 mm fine mesh WIP screens is anticipated to be significantly higher than the estimated costs for installation of 2.0 mm fine mesh dual flow screens or 2.0 mm fine mesh Ristroph screens.

#### I&E Discussion

A pilot study to determine impingement reductions provided by WIP screens was conducted at Unit 5 of the OPPD's North Omaha Station (a coal-fired generating station) by EPRI [Ref. 6.12]. Unit 5 is provided with condenser cooling water from the Missouri River by an intake structure that is divided into six cells or channels. The flow through each channel is 29,385 gpm and each channel contains a bar rack, sluice gate, and traveling water screen [Ref. 6.12]. One of the six traveling water screens was replaced with a WIP screen with square 6.1 mm (0.24 inch) openings in August 2006. The results of the pilot study indicated that WIP screens have the potential to reduce impingement mortality of channel catfish and bluegill by greater than 90%, and fathead minnow and the native Missouri River fish group, comprised primarily of emerald shiner, by 79 to nearly 85% [Ref. 6.12]. However, any impingement reductions provided by WIP screens would not be expected to be appreciable because the Stations' existing TWSs screens and fish return systems already provide state-of-the-art impingement protection (Section 3.2).

No studies investigating entrainment mortality associated with WIP screens have been performed [Ref. 6.12]. In addition, other than fine mesh panels, the WIP screens do not utilize any entrainment reducing features and would not be expected to provide additional reductions in entrainment other than physical exclusion based on the size of the mesh opening. Therefore, it is assumed that WIP screens with various mesh sizes would provide similar reductions in EA1 entrainment losses as Ristroph screens (see Table 4.1); however, as discussed in Section 4.2.1, no mesh size would be expected to provide significant additional reductions in EA1 entrainment losses.

#### Conclusions

The use of WIP screens at IPEC would not be expected to provide substantial reductions in EA1 I&E losses from the existing TWSs and fish return systems. In addition, due to the number of fine mesh WIP screens and the additional intake modifications required, the capital costs and maintenance costs associated with the installation and operation of fine mesh WIP screens would be significantly higher than the costs required for fine mesh dual flow traveling screens or fine mesh Ristroph screens. Thus, WIP screens are not further considered as an alternative to the current screening systems.

#### 4.2.5 MultiDisc® Screens

Geiger MultiDisc® Screens are not considered as viable alternatives to the current screening systems at the Stations, because the use of Geiger MultiDisc® Screens (coarse or fine mesh) would not be expected to provide substantial reductions in EA1 I&E from the existing TWSs and fish return systems.

Geiger MultiDisc® Screens are oriented the same way as traditional through flow screens (i.e., installed in a channel with the screening surface oriented perpendicular to the incoming flow). However, MultiDisc® screens are comprised of circulating sickle-shaped mesh panels that are connected to a frame via a revolving chain. The linked mesh panels are guided on each side forming a unit together with the support. The forces applied by the flowing water to the center of the mesh panels are transmitted via supporting beams to the intake structure. The center of the mesh panels are supported by rollers. Water flows directly through the mesh panels. Fish and debris retained at the face of the ascending mesh panels are transported to the floor level where they are sluiced to fish return trough and debris troughs, respectively, by spray nozzles. A typical Geiger MultiDisc® Screen is shown in Figure 4.7.

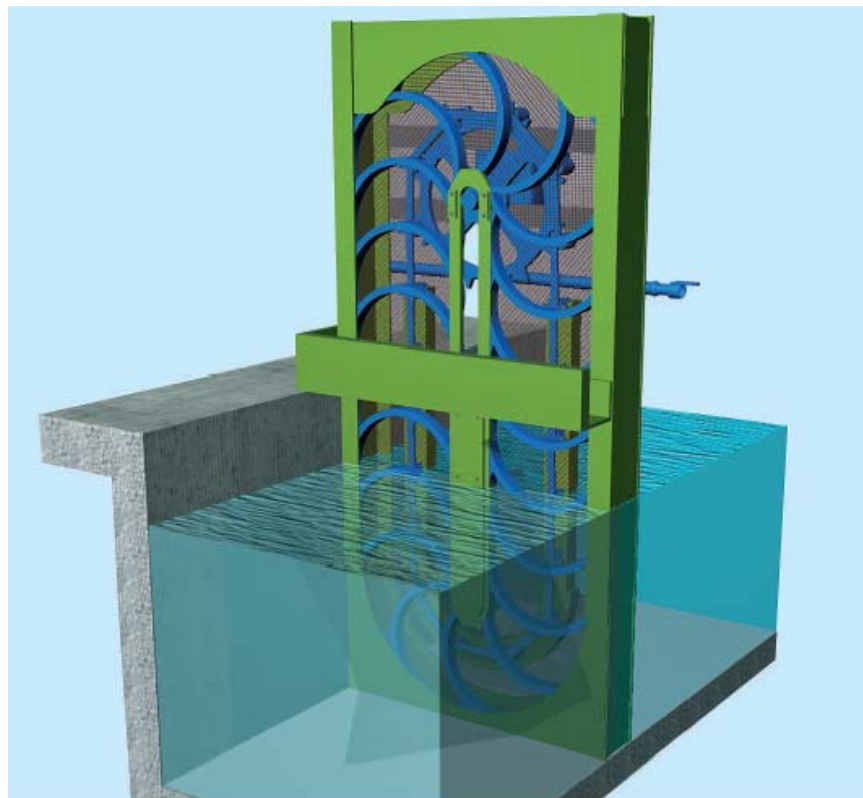

**Figure 4.7 Geiger MultiDisc® Screen [Ref. 6.96]**

MultiDisc® Screens can be modified to include provisions for reduced impingement loss of aquatic species. Fish buckets attached to the screen panels retain water during its upward travel, thereby providing captured fish with water once the fish buckets exit the water level. The fish buckets are surface treated with a sliding composite material to allow retained fish to be easily flushed from the buckets. A low pressure spray header recovers

organisms which are transported upwards on the screen surface into the bucket. Organisms impinged on the screen surface below this bucket are led via an opening in the lower panel frame into the bucket of the following mesh panel. Due to the turning system of the mesh panels at the drive unit, the fish buckets are discharged, and the retained water and fish are sluiced to a fish return trough.

MultiDisc<sup>®</sup> Screens can be constructed with fine-mesh screens designed to collect fish eggs and larvae and return them to the source waterbody. However, unlike Ristroph screens or dual flow screens, MultiDisc<sup>®</sup> screens are not designed to have removable fine mesh inserts, eliminating the possibility of seasonal deployment during periods of high entrainment.

MultiDisc<sup>®</sup> Screens have been retrofitted into the existing CWISs of nuclear power plants, including the Donald C. Cook Nuclear Plant in Michigan, the Salem Nuclear Generating Station in New Jersey, and the Fort Calhoun Station in Nebraska. Typically, MultiDisc<sup>®</sup> Screens can be retrofitted into the existing space of the current TWSs, minimizing required civil/structural modifications. However, MultiDisc<sup>®</sup> Screens are not available for the basket width required to replace the existing TWSs at the Stations. As discussed in Section 2.4.1.1, the Stations' existing TWSs have a basket width of 13 ft 4 inches, but due to design constraints, the largest basket width manufactured by Geiger is 10 ft (see Attachment 1, Section 4). The deflection of the sickle-shaped panels caused by debris loads limits the basket width of MultiDisc<sup>®</sup> Screens, because debris-loaded panels deflect at their center resulting in premature wear and deterioration. Implementation of fine mesh MultiDisc<sup>®</sup> screens in the existing CWISs would further increase the through-screen velocity and impingement mortality, due to the decrease in net porosity of the screen.

In order to provide a through-screen velocity at or below 0.5 fps, the size of the CWISs would need to be expanded to accommodate fine mesh MultiDisc<sup>®</sup> screens at the Stations. The number of fine mesh MultiDisc<sup>®</sup> screens required to maintain a through-screen velocity at or below 0.5 fps can be determined by using the equation previously referenced in Section 2.4.2.4 and multiplying the basket width and mean low water terms in the equation by 80 percent. The 20 percent reduction of the screening area conservatively accounts (i.e., understates the reduction in screening area) for submerged components of the MultiDisc<sup>®</sup> screen that reduce the flow area of the screen such as the base frame, central panel guide, and panel frames. Six 2.0 mm fine mesh MultiDisc<sup>®</sup> screens with a wire thickness of 0.5 mm would be required per intake channel (140,000 or 143,200 gpm) to maintain a through-screen velocity at or below 0.5 fps.

A conceptual design for 2.0 mm fine mesh MultiDisc<sup>®</sup> screens at the Stations would be similar to the conceptual configuration for fine mesh dual flow and fine mesh Ristroph screens shown in Figures 2-4 through 2-6 and Figures 2-1 through 2-3 of Attachment 2, respectively. However, the size of the expanded intake would be larger because each of the new dedicated forebays would contain six fine mesh MultiDisc<sup>®</sup> screens. The width of the expanded intake for 2.0 mm fine mesh MultiDisc<sup>®</sup> screens providing screened cooling water to three CW channels would be approximately 260 ft wide assuming 11 ft 4 in wide screen channels and 3 ft thick walls. Each fine mesh MultiDisc<sup>®</sup> screen would be paired with new bar racks and stop logs providing large debris removal and isolation of the screens for repair or maintenance. Due to the size of the expanded intake required,



implementation of fine mesh MultiDisc<sup>®</sup> screens would require more civil/structural and mechanical modifications than the implementation of fine mesh dual flow screens or fine mesh Ristroph screens.

#### Maintenance

MultiDisc<sup>®</sup> screens should require less maintenance than the existing TWSs because each screen panel can be individually removed at floor level and because the screening unit contains a single side bar chain. MultiDisc<sup>®</sup> screens would eliminate debris carryover into the condensers, reducing maintenance costs associated with the condensers. However, overall maintenance costs and time are expected to increase significantly for 2.0 mm fine mesh MultiDisc<sup>®</sup> screens, compared to the current TWSs due to the number of screens required to screen the normal intake flows of Units 2 and 3 (72 total 2.0 mm MultiDisc<sup>®</sup> screens). Due to the increased number of screens required for the implementation of 2.0 mm MultiDisc<sup>®</sup> screens, maintenance costs would be expected to be approximately six times the current costs required to maintain the existing coarse mesh TWSs.

Because fine mesh screens are more susceptible to biofouling than coarse mesh screens, it is likely that a sodium hypochlorite system would be required to periodically dispense sodium hypochlorite in front of any fine mesh MultiDisc<sup>®</sup> screens to provide biofouling control. Any addition of sodium hypochlorite to the CW systems would need to be evaluated for potential impacts to the SPDES permit [Ref. 6.86].

#### Cost

The estimated cost for the MultiDisc<sup>®</sup> screen components (i.e., screens, pumps, and controllers) is 1.4 times the cost of the fine mesh Ristroph screen components and 1.5 times the cost of the fine mesh dual flow screen components (see Attachment 1, Section 4). In addition, due to the number of MultiDisc<sup>®</sup> screens required and the extensive civil/structural work required for the expanded intake structures, the estimated capital costs for the installation of conceptual 2.0 mm fine mesh MultiDisc<sup>®</sup> screens is anticipated to be significantly higher than the estimated costs for installation of 2.0 mm fine mesh dual flow screens or 2.0 mm fine mesh Ristroph screens.

#### I&E Discussion

The number of 2.0 mm MultiDisc<sup>®</sup> screens incorporated into the conceptual design is based on a maximum through-screen velocity of 0.5 fps. According to the EPA, if a facility could reduce its maximum through-screen velocity to at or below 0.5 fps, it would be considered to have satisfied the standard for reducing impingement mortality. However, any impingement reductions provided by MultiDisc<sup>®</sup> screens would not be expected to be appreciable compared to the Stations' existing TWSs screens and fish return systems (see Section 3.2). Due to the similarities in the method of entrainment for MultiDisc<sup>®</sup> screens and Ristroph screens (fish pass through mesh panels oriented perpendicular to the flow), MultiDisc<sup>®</sup> screens would be expected to provide similar reductions in EA1 entrainment losses as Ristroph screens (Table 4.1). However, as discussed in Section 4.2.1, no mesh size would be expected to provide significant additional reductions in EA1 entrainment losses.

### Conclusions

The use of MultiDisc<sup>®</sup> screens at the Stations would not be expected to provide substantial reductions in EA1 I&E from the existing TWSs and fish return systems. In addition, due to the number of screens and the additional intake modifications required, the capital costs and maintenance costs associated with the installation and operation of MultiDisc<sup>®</sup> screens would be significantly higher than the costs required for dual flow traveling screens or Ristroph screens. For these reasons, MultiDisc<sup>®</sup> screens are not further considered as an alternative to the current screening systems.

## **4.3 Passive Intake Systems**

### **4.3.1 Cylindrical Wedgewire Screens**

Each of the cylindrical wedgewire screen (CWW) mesh sizes evaluated (2.0 mm to 9.0 mm) would be expected to achieve substantial additional EA1 I&E reductions from the regulatory baseline, and would be comparable to the NYSDEC Proposed Project. However, because CWW screens with smaller slot sizes would create significant opportunity for fouling, a site-specific study of slot sizes ranging from 2.0 mm to 9.0 mm is proposed to determine the optimum slot width for reducing I&E at which fouling would not be a concern.

CWW screens (see Figure 4.8) are designed to reduce I&E in three ways. First, depending on slot size, CWW screens provide a physical barrier preventing aquatic organisms larger than the screen slot size from being entrained. Second, CWW screens are located directly in a source waterbody (and not in a screen house), so sweeping flows can remove organisms from the intake flow field (this increases the effectiveness of avoidance discussed next). Sweeping flows also reduce impingement by moving organisms past the CWW screens, minimizing contact. Third, hydrodynamic exclusion of early life stages results from the low through-slot velocity of the CWW screen that is quickly dissipated, allowing organisms to escape the intake flow field. Larvae too small to be physically excluded by CWW screens have shown an active avoidance response to the changes in flow velocity and direction created by CWW screens [Ref. 6.39]. As discussed in Attachment 6, this avoidance and hydrodynamic exclusion model results in additional reductions in EA1 entrainment losses.



**Figure 4.8 Cylindrical Wedgewire Screen**

CWW screens are designed to provide a large screening area, and a low through-slot velocity (i.e., at or below 0.5 fps) [Ref. 6.94]. The screening surface consists of “V”-shaped “wedge wire” bars that are welded to support rods at their apex and are formed to maintain a uniform screen opening. The slot size is defined as the dimension of the opening between the wide ends of the wedge wire bars. CWW screens with slot sizes larger than 2.0 mm are typically considered to be wide slot screens, while CWW screens with slot sizes of 2.0 mm and smaller are considered to be narrow slot screens. Figure 4.9 shows a detailed view of the wedgewire screening material.

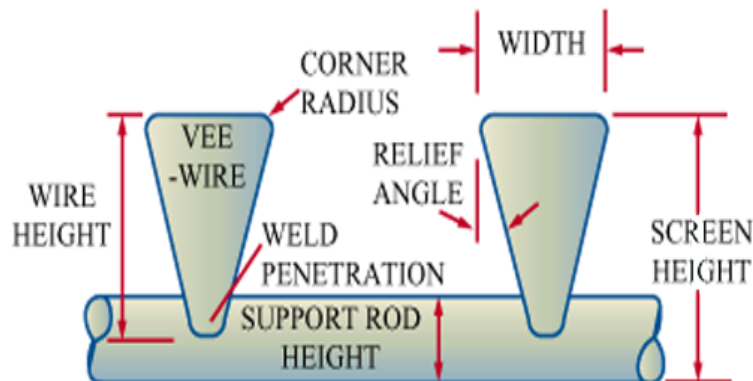

**Figure 4.9 Wedgewire Screening Material**

As shown in Figure 4.10, the shape of the wedge wire bars increases the flow area of the screen surface while reducing obstruction of the screen surface by debris accumulation.

The sharp edges of the wire profile allow for solid particles to make only two points of contact with the screen surface.

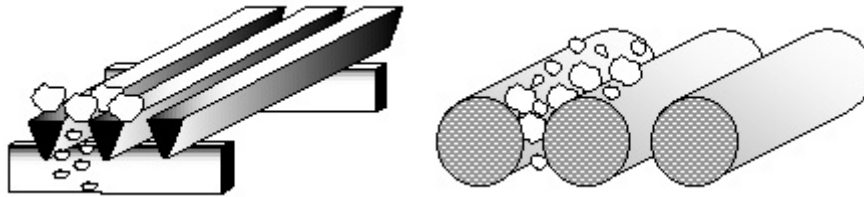

**Figure 4.10 Profile of Wedgewire Material (Left) and Round Wire Material (Right)**

Debris loading and fouling can lead to higher capture velocities and damage early life stage organisms. As such, CWW screen systems can utilize airburst systems that release compressed air through the screens, forcing accumulated debris from the screen surface. As shown in Figure 4.11, an airburst system consists of an air compressor and receiver, a distribution manifold, a control system, and an individual screen air distributor. Debris removed from the screening surface by the airburst system is carried away by the sweeping current of the waterway.

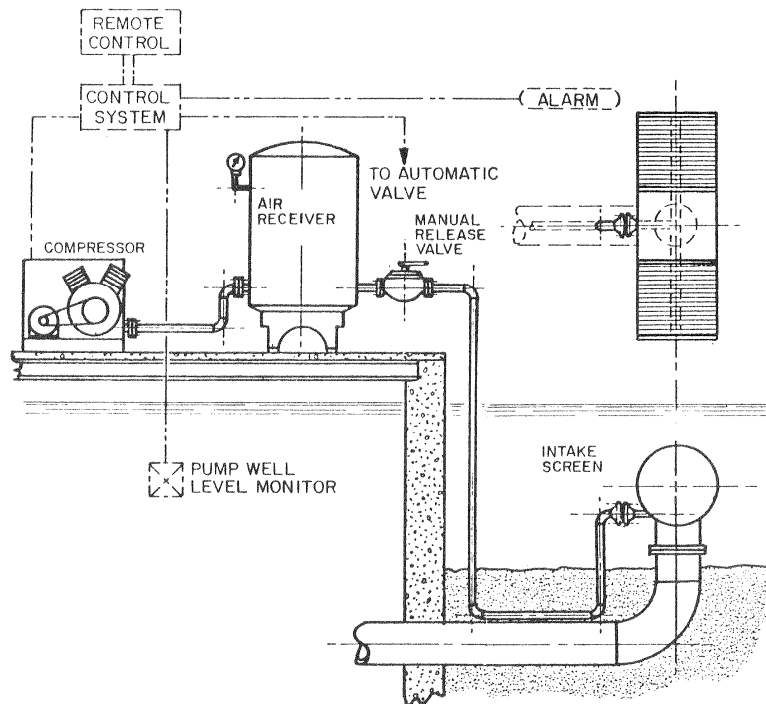

**Figure 4.11 Typical CWW Screen Airburst System [Ref. 6.94]**

Early CWW screen designs and perforated pipe intakes (obsolete intake screening systems that predate CWW screens, discussed further in Section 4.3.2), had inherent design issues that have been addressed through the development of CWW screens. These developments include:

- Internal flow modifications that allow CWW screens to achieve an even velocity distribution across the screen surface area, avoiding areas of high flow concentration. The internal modifications prevent uneven flow distributions. Prior to these modifications, most of the flow would enter the screen through the slots nearest the supply pipe, creating a localized area with high through-slot velocities. In addition, the internal flow modifications allow the length of the screens to be increased, resulting in increased flow through an individual CWW screen; previously, the length of the CWW screens was limited to the size of the screen diameter.
- Airburst systems designed to effectively remove debris from the screen surfaces.
- The use of “V” shaped “wedge wire” bars to increase the flow area of the screen surface while reducing obstruction of the screen surface by debris accumulation.
- The use of different screening materials to reduce biofouling. As shown in Attachment 1, Section 5, CWW screens constructed of a copper-nickel alloy are designed to provide protection against biofouling, specifically zebra mussels.

These developments have led to improved reliability of CWW screen installations and increased operational effectiveness.

There are no applications of CWW screens at nuclear power facilities. However, CWW screens have been effectively used in fossil-fueled power generation facilities. Oak Creek Power Plant in Milwaukee, Wisconsin operates the largest installation of CWW screens. It has four operating Units online that generate a total of 1135 MWe. The Oak Creek CWW screen system includes an offshore intake system situated approximately 6000-7000 ft from the shoreline at a depth of approximately 43 ft. According to Oak Creek (see Attachment 1, Section 6), the CWW system became operational in January 2009 and is designed to operate year round. The offshore intake system uses twenty-four (24) 8-ft diameter CWW screens with a slot size of 0.375 inches to filter a flow rate of 1,560,000 gpm (see Attachment 1, Section 6). The total intake flow rate at Oak Creek is comparable to the total intake flow rate at IPEC Units 2 and 3. The CWW screen system at Oak Creek was designed to provide a through-screen velocity at or below 0.5 fps and the system was oversized by approximately 16% (3 additional screens) to provide a margin against fouling. Johnson Screens, a leading CWW screen manufacturer, supplied Oak Creek’s CWW screens. The entire screen assemblies are manufactured from copper-nickel alloy. The CWW screens are mounted to 4 manifolds; six CWW screens are mounted to each manifold. The manifolds are connected to drop tunnels that discharge into a single transmission tunnel that flows towards the shoreline into the plant’s wetwell. The transmission tunnel was bored into the bedrock and has a total length of 9200 ft. Cooling water from the wetwell is subsequently pumped to the condenser of each Unit.

At Oak Creek, flow reductions, potentially caused by fouling and the associated differential pressure increases across the CWW screen system, are measured by gauging the water level in the wetwell. The original shoreline intake system remains operational and is

isolated using stop logs, so that, in the event that flow through the CWW screen system is not available or reduced, the stop logs can be manually opened to restore flow to the facility using lifts actuated by heavy-duty electric wrenches. Due to the distance of the offshore intake to the facility, Oak Creek's CWW system is not equipped with an airburst system; however, fouling of the CWW screens is not a significant concern based on the characteristics of the source waterbody (Lake Michigan). Biofouling caused by zebra mussels has not been an issue due to the use of copper-nickel alloy screens. A frazil ice fouling event<sup>15</sup> occurred early in 2009; however, flow through the CWW system was quickly restored without compensatory actions.

CWW screen systems have also been installed at facilities located on the Hudson River. The Charles Point Resource Recovery Facility (Charles Point), formerly known as Westchester RESCO, is located approximately ½ mile northwest of IPEC on the eastern shoreline of the Hudson River. Charles Point is a waste to energy facility that produces approximately 60 MWe and utilizes a once-through cooling system with a flow rate of 55 MGD. The cooling water intake utilizes 2.0 mm CWW screens installed in 1986 to draw water at an offshore distance of approximately 800 ft. There are eight (8) 54 inch diameter CWW screens constructed of a copper nickel alloy situated in four pairs on T-stands approximately 5 ft above of the Riverbed. According to Charles Point (see Attachment 1, Section 7), the CWW screens at Charles Point operate year round and utilize an airburst system that discharges twice daily via timers. A dive team is dispatched annually to visually inspect the screens. If there are local areas of debris buildup identified during the inspection dive, the divers will remove the debris. Flow reductions due to frazil ice were reported to occur during periods of extreme cold temperatures combined with low River water levels. These events were reported to occur every 2-3 years, and flow through the CWW screens is restored by using the airburst system. No other operational issues associated with the Charles Point CWW screens were reported.

Two 0.125-inch slot CWW screens are installed at the IBM facility in Poughkeepsie, NY and provide Hudson River water for the facility's HVAC chillers (see Attachment 1, Section 8). The CWW screens at the IBM facility have a maximum intake flow rate of 60,000 gpm per screen. According to the Facility Engineer (Attachment 1, Section 8), the stainless steel screens were installed in the early-1980s and operate year round. The CWW screens are equipped with an airburst system that discharges hourly. The CWW screens were removed and inspected in 2004 for potential damage caused by impacts from ice floes. Minor dents and a small quantity of zebra mussels were identified. Flow through the CWW screens is maintained using the airburst system. No significant fouling issues were reported, although minor icing reportedly occurs during winter months. No other operational issues associated with the IBM facility's CWW screens were reported.

In order to filter the required 840,000 gpm of CW flow per Unit at IPEC, multiple CWW screens would be required. In addition, several different slot sizes were preliminarily evaluated for the Stations. Table 4.2 shows the number and size of CWW screens that

---

<sup>15</sup> Granular ice crystals formed in turbulent, supercooled water are referred to as "frazil ice." Supercooled water occurs when the water temperature begins to drop and passes through the 32°F point. At a temperature of less than 32°F, tiny particles of ice form quickly and uniformly through the water mass. Frazil ice is extremely adhesive and will stick to any solid metallic object that is at or below the freezing point.

would be required to maintain the CW flow while retaining a maximum through-slot velocity at or below 0.5 fps.

**Table 4.2 Wedgewire Screens Required to Maintain Minimum Through-Slot Velocity of 0.5 fps**

Slot Size	# of Screens	Screen Length	Screen Diameter
9.0 mm (~ 3/8 inch)	48	257 inch	72 inch
6.0 mm (~ 1/4 inch)	48	267 inch	66 inch
3.0 mm (~ 1/8 inch)	72	239 inch	66 inch
2.0 mm (0.078 inch)	72	257 inch	72 inch
1.5 mm (0.059 inch)	60	300 inch	84 inch
1.0 mm (0.040 inch)	72	300 inch	84 inch

Low through-slot velocities would be used to ensure that organisms are not impinged on the screen because they cannot swim away from the intake velocity. According to the Hudson River Power Plants Final Environmental Impact Statement [Ref. 6.88], although EPA typically recommends CWW through-slot velocities at or below 0.5 fps, NYSDEC has indicated interest in through-slot velocities at or below 0.25 fps. As such, Table 4.3 shows the number and size of CWW screens that would be required to maintain the CW flow while retaining a maximum through-slot velocity of 0.25 fps or less.

**Table 4.3 Wedgewire Screens Required to Maintain Minimum Through-Slot Velocity of 0.25 fps**

Slot Size	# of Screens	Screen Length	Screen Diameter
9.0 mm (~ 3/8 inch)	96	257 inch	72 inch
6.0 mm (~ 1/4 inch)	96	267 inch	66 inch
3.0 mm (~ 1/8 inch)	144	239 inch	66 inch
2.0 mm (0.078 inch)	144	257 inch	72 inch
1.5 mm (0.059 inch)	120	300 inch	84 inch
1.0 mm (0.040 inch)	144	300 inch	84 inch

Because CWW screens with smaller slot sizes would create significant risk of fouling, only designs for CWW screen systems with slot sizes ranging from 2.0 mm (i.e., the slot size

used at Charles Point) to 9.0 mm (the slot size used at Oak Creek) were developed in an attempt to minimize both entrainment and fouling.

- Conceptual layout drawings of potential 9.0 mm and 2.0 mm slot CWW screen systems sized for through-slot velocities of 0.5 fps are shown in Attachment 2, Figures 2-9 and 2-11, respectively. Plan and detail drawings associated with the layout drawings of systems sized for through-slot velocities of 0.5 fps are shown in Attachment 2, Figures 2-10 and 2-12.
- Conceptual layout drawings of potential 9.0 mm and 2.0 mm slot CWW screen systems sized for through-slot velocities of 0.25 fps are shown in Attachment 2, Figures 2-13 and 2-15, respectively. Plan and detail drawings associated with the layout drawings of systems sized for through-slot velocities of 0.25 fps are shown in Attachment 2, Figures 2-14 and 2-16.

These layouts depict arrays of CWW screens attached to transmission piping that flows into common headers leading into the CWISs. The CWW screen systems would be located within the IPEC's existing exclusion zone; thus, implementation of the CWW screen systems would not limit navigability of the Hudson River. As shown in the plan and detail drawings, the common headers would connect to the CWISs downstream of the TWSs, allowing the existing screening systems to maintain operability. Newly installed stop logs and isolation valves would enable the CWW screen arrays to be isolated for maintenance, repair, or seasonal operation.

The conceptual CWW screen systems would be equipped with sensors in the CW pump pits monitoring water elevation. Decreases in water elevation would typically indicate debris accumulation on the screen surfaces, because fouling of the CWW screen slots adds further resistance to the flow of intake water and results in reduced flow volumes. When a predetermined water elevation was reached, the airburst system would be activated. The airburst cycle would dislodge debris from the CWW screens, returning the water level to an acceptable level. The sensors would also monitor the effectiveness of the airburst system in removing debris from the screen surfaces by measuring the water elevation following an airburst cycle. If the airburst systems could not adequately remove debris from the CWW screen surfaces, the water elevation would continue to fall until a second, lower water elevation was reached. At this lower water elevation, hydraulic operators installed on the existing stop logs would be used to raise the stop logs allowing cooling water to be withdrawn from the Hudson River through the existing TWSs. The stop log system would ensure a reliable supply of cooling water, preventing air intrusion and cavitation in the CW pumps, which could lead to unnecessary, unplanned reactor shutdowns.

There are several considerations with respect to the retrofit of CWW screens at the Stations summarized below:

- CWW screens are susceptible to damage and clogging due to ice formation on the screens during the winter months. Granular ice crystals formed in turbulent, supercooled water are referred to as "frazil ice." Supercooled water occurs when the water temperature begins to drop and passes through the 32°F point. At a temperature of less than 32°F, tiny particles of ice form quickly and uniformly



through the water mass. Frazil ice is extremely adhesive and will stick to any solid metallic object that is at or below the freezing point [Ref. 6.94]. CWW screens are highly susceptible to formation of ice on the screens, as documented by the U.S. Army Corps of Engineers [Ref. 6.112]. Although the Stations do not have a history of frazil ice issues with the existing CWISs, due to the location of the CWW screens and the general susceptibility of CWW screens to frazil ice, any site-specific CWW pilot study would evaluate potential frazil ice events.

- Water flow through CWW screens, and their effectiveness with respect to entrainment, can be limited by debris buildup on the surface of the screens and siltation below the screens. Debris buildup can be periodically removed from the CWW screen surfaces by utilizing an airburst system. Without a sweeping current, the dislodged debris could resettle on the screen surface. A minimum sweeping current of at least 1 fps past the CWW screens is recommended to minimize clogging from debris accumulation [Ref. 6.115]. The Hudson River has two flood and two ebb tides within a 24.8-hour period, referred to as a semidiurnal pattern (see Section 2.3.1). The average sweeping current of the Hudson River is 1.0 fps for the flood tides and 2.1 fps for the ebb tides based on maximum observed velocities. The actual slack tide lasts for a short period as the tide changes between flood and ebb conditions. The sweeping current during the ebb and flood tides should be sufficient to facilitate adequate cleaning of the CWW screens using an airburst system. As shown in the layout drawings (Attachment 2, Figures 2-9 through 2-16), a CWW screen system at the Stations would require an array of screens that would be situated a minimum of 40 ft offshore to allow clearance for transmission piping, isolation valves, and dredging.
- Any CWW screens used at the Stations would need to maintain the consistent intake flow required for cooling. Typically, smaller slot size screens are more susceptible to fouling, which can reduce flow. On-site physical testing would be required at the Stations to determine the optimum slot size that would address entrainment goals while ensuring a reliable flow of cooling water.
- Adequate CW pump submergence is required to prevent air intrusion into the circulating water pumps, and a submergence margin is employed to prevent this occurrence because air intrusion and cavitation in the CW pumps could lead to unnecessary, unplanned reactor shutdowns. The resistance of the CWW screens (assumed clear of fouling or clogging) and the associated piping systems would reduce the water elevation within the CWISs and, therefore, the submergence of the CW pumps. As fouling or clogging of the CWW screens occurred, resistance through the screens would increase, causing additional water level drop in the pump bay and a reduced submergence margin for each pump. In order to avoid damage to the CW pumps caused by air entrainment, the evaluated design of the CWW screen systems require the existing CW pump pits to be excavated and deepened by approximately 6 ft. New extended pump shafts and impellers would be installed on the existing CW pumps. Deepening of the existing CW pump pits, along with installation of extended pump shafts and impellers, would ensure the submergence margin and water level required to prevent the effects of air entrainment.

In order to establish a CWW screen system that balances biological and operational effectiveness, a laboratory study of CWW screen systems would be recommended prior to full-scale implementation of a CWW screen system at Unit 2 or Unit 3. Additionally, a small scale on-site pilot study would also be recommended to begin evaluating the site-specific fouling and operational issues, including the installation of CWW screens at a single CW pump bay. The on-site study should continuously monitor pressure differential (head loss) across the screen surface as the increases in pressure differential due to fouling would be used to design set points and operational frequency of the air backwash system. The on-site study should identify the optimal location and orientation of the screen arrays within the River, and the optimal vertical location of the CWW screens off of the Hudson River bed. In particular, the minimal height off of the River bed that eliminates the possibility of siltation should be identified and the temperature gradient with respect to depth in the water column should be established.

Test deployment of the screens should be year-round to determine if River conditions are acceptable for year-round CWW screen operation, similar to Charles Point and the IBM Facility. Several different screening materials (304SS/316L/Z-Alloy) would also be tested to determine the optimum material to resist corrosion and biofouling. The study should also attempt to identify fouling sources and fouling rates. The fouling sources and rates should be established for each month of operation to identify periods of high vulnerability (e.g., eelgrass could be problematic in the spring, while leaves could be a concern in the fall, or icing in the winter).

Based on these study results, installation and operation of a full scale CWW screen system and airburst system at one Unit would be recommended. This installation would allow the Stations to more fully evaluate the performance of a CWW screening system at the Stations. The particular engineering parameters studied would include the frequency of airburst operation required to maintain a through-slot velocity at or below 0.5 fps and the optimum placement of the CWW screens in the water column to avoid siltation, icing, and fouling.

#### Maintenance

The use of narrow slot openings (i.e., 2.0 mm and smaller) dictates that the screens should be closely monitored and inspected at more frequent intervals. When the screens are initially installed, they should be inspected on a quarterly basis for the first 12 to 15 months of operation to monitor fouling/icing. Once the rate of fouling/icing has been established, inspection frequency should be altered to coincide with fouling/icing patterns.

The evaluated CWW screens would have several O&M requirements as detailed below:

- Inspect airburst systems
- Activate air cleaning systems periodically to clean CWW screens
- Inspect/lubricate isolation valves
- Manually exercise isolation valves
- Inspect CWW screens using divers or cameras
- Manually brush and/or hydroclean CWW screens

When debris accumulates on the screen body, the screens would be cleaned with an airburst system. Operations personnel would likely perform O&M activities associated with maintenance of the airburst systems and isolation valves. The frequency of manual cleaning of the screens would need to be determined by operations after installation in order to account for conditions specific to the Hudson River.

The maintenance costs would include the costs required to maintain the existing coarse mesh TWSs, the new airburst systems, and the new stop log systems. Additional underwater inspection and cleaning of the CWW screens would likely be performed by a subcontracted team of divers. Additionally, parasitic power losses due to the operation of air compressor motors for the airburst systems were evaluated. The estimated power requirements per Unit are based on two 35 hp motors operating continuously for 52 weeks. Based on these assumptions, the additional parasitic losses associated with operation of the air compressor motors for the airburst systems at each Unit would be approximately 456 MW-hr per year (912 MW-hr per year, total) for a CWW system designed for a through-slot velocity of 0.5 fps. For a CWW system designed for a through-slot velocity of 0.25 fps, the additional parasitic losses associated with operation of the air compressor motors for the airburst systems at each Unit would be approximately 912 MW-hr per year (1824 MW-hr per year, total).

#### Cost

The capital cost estimates for the implementation of the evaluated CWW screens at the Stations are detailed in Attachment 4. Equipment quotes from vendors are provided in Attachment 1. The total estimated capital costs for the installation of copper-nickel CWW screens at IPEC Units 2 and 3 with a through-slot velocity of 0.5 fps and airburst cleaning would be approximately \$41.7 million for 2.0 mm screens, and approximately \$36.5 million for 9.0 mm CWW screens. The total estimated capital costs for the installation of copper-nickel CWW screens at IPEC Units 2 and 3 with a through-slot velocity of 0.25 fps and airburst cleaning would be approximately \$63.3 million for 2.0 mm screens, and approximately \$52.0 million for 9.0 mm CWW screens. As shown in Attachment 1 Section 5, CWW screens constructed of copper-nickel could provide further protection against biofouling, specifically zebra mussels.

Several unknown factors associated with the conceptual CWW system design developed above would require resolution during the detailed design phase. These factors include: (1) design and analysis to evaluate potential flow issues within the CWISs and vortexing by the CW pumps, (2) uneven bathymetry in the River in front of the Stations requiring a different footprint or non-standard installation techniques for the CWW screen arrays, and (3) the extent of laboratory and site-specific tests of the CWW screen arrays. These factors could more than double the costs, increasing the total cost of implementing CWW screen systems to more than \$100 million.

Excavation of the existing CW pump pits and the tie-in of the CWW screen headers would take approximately six to eight weeks per pump pit, assuming that construction activities are performed 24 hours per day. Excavation of a single pump pit at each Unit could be conducted simultaneously, allowing the Units to remain online although a reduction in load would result from the reduced CW flow. Therefore, the Stations would experience approximately 36 to 48 weeks of reduced generating capacity at each Unit during

construction. Note that this is a conservative construction estimate and is considered a ‘best case’ scenario because actual construction scheduling would be dependent on numerous unknown factors including the geologic composition of the material below the pump pits, the ability of construction activities to be performed due to local weather conditions, and the ability to work 24 hours per day. Several excavation and tie-in construction tasks would require a full Unit outage to be completed; however, it is likely that these tasks could be scheduled to coincide with a routine maintenance outage for each Unit. Refueling outages are anticipated to last approximately 25 days (almost 4 weeks); therefore, there would be a total of approximately 32 to 44 weeks of reduced generating capacity at each Unit during the implementation of the evaluated CWW screen options. As discussed in Section 2.1, the Stations currently generate electricity at a rated capacity of approximately 1078 MWe and 1080 MWe for Units 2 and 3, respectively. A 32 to 44 week period of reduced generating capacity would result in a loss of approximately 22,000 to 30,000 MW-hrs at Unit 2, and approximately 11,000 to 16,000 MW-hrs at Unit 3. If the required construction and tie-in activities could not be scheduled to coincide with a routine maintenance outage, the construction costs would increase.

#### I&E Discussion

As noted earlier, CWW screens are designed to reduce I&E in three ways. First, depending on slot size, CWW screens provide a physical barrier preventing aquatic organisms larger than the screen slot size from being entrained. Second, since CWW screens are located directly in a source waterbody (and not in a screen house), sweeping flows can remove organisms from the intake flow field (this increases the effectiveness of avoidance). Sweeping flows also reduce impingement by moving organisms past the CWW screens, minimizing contact. Third, hydrodynamic exclusion of early life stages results from the low through-slot velocity of the CWW screen that is quickly dissipated, allowing organisms to escape the intake flow field. Larvae too small to be physically excluded by CWW screens have shown an active avoidance response to the changes in flow velocity and direction created by CWW screens [Ref. 6.39]. As discussed in Attachment 6, this avoidance and hydrodynamic exclusion model results in additional reductions in EA1 entrainment losses.

Attachment 6 (Tables 17 and 23 of Appendix A) provide the estimated reductions from the regulatory baseline in EA1 losses that could be achieved using 9.0, 6.0, 3.0, 2.0, 1.5, and 1.0 mm CWW screens sized for through-slot velocities at or below 0.5 fps, including the Stations’ survival rates (Attachment 6) and average historic flow reductions (Section 2.4.2.3.2). A summary of the information included in the tables is shown in Table 4.4. Note that the maximum possible reductions in EA1 I&E shown in Table 4.4 (99.9% and 89.8%, respectively) are substantially higher than the current EA1 I&E reductions (80.2% and 33.8%, respectively) shown in Section 3.2.

**Table 4.4 Potential Percent Reduction of Annual EA1 I&E Losses due to CWW Screens in Each Month with Through-Slot Velocities of 0.5 fps**

Month	EA1 Entrainment Loss Reduction						EA1 Impingement Loss Reduction
	9.0 mm	6.0 mm	3.0 mm	2.0 mm	1.5 mm	1.0 mm	
January	0.0%	0.0%	0.0%	0.0%	0.0%	0.0%	9.6%
February	0.0%	0.0%	0.0%	0.0%	0.0%	0.0%	10.5%
March	0.0%	0.0%	0.0%	0.0%	0.0%	0.0%	13.1%
April	0.5%	0.5%	0.5%	0.5%	0.5%	0.5%	8.2%
May	8.3%	8.3%	8.3%	8.3%	8.3%	7.9%	10.0%
June	28.2%	28.2%	28.2%	28.3%	28.2%	27.7%	12.7%
July	26.5%	26.5%	26.5%	26.5%	26.6%	26.6%	5.5%
August	14.8%	14.8%	14.8%	14.8%	14.8%	14.8%	5.7%
September	6.4%	6.4%	6.4%	6.4%	6.4%	6.4%	6.0%
October	4.9%	4.9%	4.9%	4.9%	4.9%	4.9%	5.1%
November	0.0%	0.0%	0.0%	0.0%	0.0%	0.0%	5.7%
December	0.0%	0.0%	0.0%	0.0%	0.0%	0.0%	7.8%
Annual	89.6%	89.6%	89.7%	89.8%	89.7%	88.8%	99.9%

An evaluation of the cumulative benefits of reductions in I&E over the expected lifetimes of Unit 2 and Unit 3 was provided in Attachment 6, accounting for both expected annual reductions in I&E losses and for the implementation time required for the technologies. For the cumulative benefits analysis, it was assumed that CWW screens could be installed and operating at Unit 2 in 2013 and at Unit 3 in 2015, the NYSDEC Proposed Project would become operational at both Units in 2029, and that both Units would cease operation in 2035.<sup>16</sup> As discussed in ENERCON's Engineering Feasibility and Costs of Conversion of Indian Point Units 2 and 3 to a Closed-Loop Condenser Cooling Water Configuration [Ref. 6.22], implementation of the NYSDEC Proposed Project would involve extended delays due to the technical complexity of the project, permitting requirements, and likely litigation relating to local zoning ordinances. Other technologies that are nearly as effective as the NYSDEC Proposed Project at reducing I&E losses, such as CWW screens, could be installed much sooner; therefore, reductions in I&E losses could begin almost immediately rather than being deferred for an extended period while technical and legal issues associated with the NYSDEC Proposed Project are resolved. Because of the earlier installation date, cumulative reductions in I&E losses over the lifetimes of Units 2 and 3 could be much greater for alternative technologies than for the NYSDEC Proposed Project. According to Attachment 6 (Appendix A, Table 27), the NYSDEC Proposed Project would result in only a 50% cumulative reduction in estimated

<sup>16</sup> As discussed in Attachment 6, the installation schedule for CWW screens is consistent with a proposal based on studies of this technology. The installation schedule for the NYSDEC Proposed Project was derived by ENERCON [Ref. 6.22] with input from counsel to Entergy and Spectra Energy Transmission (owner of the gas pipeline that would have to be re-located in order to construct the NYSDEC Proposed Project).

EA1 entrainment losses and an 86% cumulative reduction in estimated EA1 impingement losses, compared to the regulatory baseline. The reason for this is that, for most of the years between 2013 and 2029, the existing technology would still be operating. In contrast, for CWW screens, estimated cumulative total EA1 impingement and entrainment losses would be reduced by approximately 98% and 87%, respectively. These results indicate that the CWW screens would be substantially more effective than the NYSDEC Proposed Project at reducing I&E below the losses associated with the existing technology.

### Conclusions

Estimated capital costs associated with the installation of CWW screens with a through-slot velocity of 0.5 fps would be approximately \$41.7 million for 2.0 mm screens, and approximately \$36.5 million for 9.0 mm CWW screens. The estimated capital costs for the installation of CWW screens with a through-slot velocity of 0.25 fps would be approximately \$63.3 million for 2.0 mm screens, and approximately \$52.0 million for 9.0 mm CWW screens. As described previously, several unknown factors associated with the conceptual CWW system design developed above would require resolution during the detailed design phase. These factors could more than double the costs, increasing the total cost of implementing CWW screen systems to more than \$100 million. There would also be a loss of approximately 33,000 to 46,000 MW-hrs due to the CW pump pit excavation and construction. As shown in Table 4.4, each of the mesh sizes evaluated would be expected to achieve substantial reductions in EA1 I&E, comparable to the NYSDEC Proposed Project. In addition, according to Attachment 6, the estimated cumulative total reduction in EA1 entrainment losses for CWW screens (88%) would be greater than the estimated cumulative total reduction in EA1 entrainment losses for the NYSDEC Proposed Project (55%). Because CWW screens with smaller slot sizes would create significant opportunity for fouling, slot sizes ranging from 2.0 mm to 9.0 mm were selected for initial evaluation in an attempt to minimize both entrainment and fouling. A site-specific engineering and biological effectiveness study would be required to determine the optimum slot width for reducing EA1 entrainment losses while limiting fouling.

### **4.3.2 Perforated Pipe Inlets**

Perforated pipe inlets are obsolete systems that have been replaced by the development of CWW screens. They are not considered as viable alternatives to the existing technologies at the Stations, due to serious operational risks, including increased head loss across the screen face, poor velocity distribution across the screens, and surface profiles prone to clogging or snagging.

Perforated pipe inlets draw water through round or elongated perforations in cylindrical plate sections placed in a water body. Perforated pipe inlets are designed to produce low through-screen velocities. When implementing perforated pipe inlets, the perforated sections are situated parallel to the ambient current in order to use the sweeping flow to reduce impingement. Perforated pipe inlets can be designed in multiple configurations as shown in Figure 4.12. Plan and profile views of a perforated pipe inlet system are shown in Figure 4.13, and a plan view of the perforated pipe sections is shown in Figure 4.14.

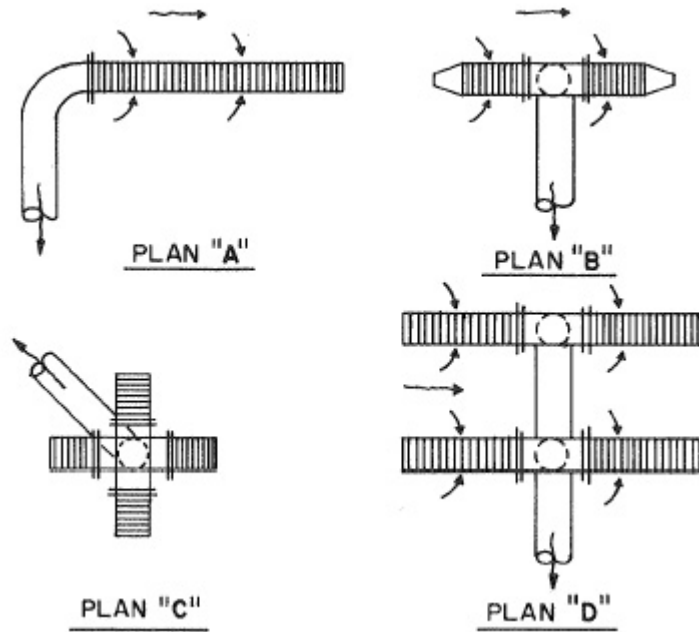

**Figure 4.12 Plan Views of Perforated Pipe Inlet Variations [Ref. 6.2]**

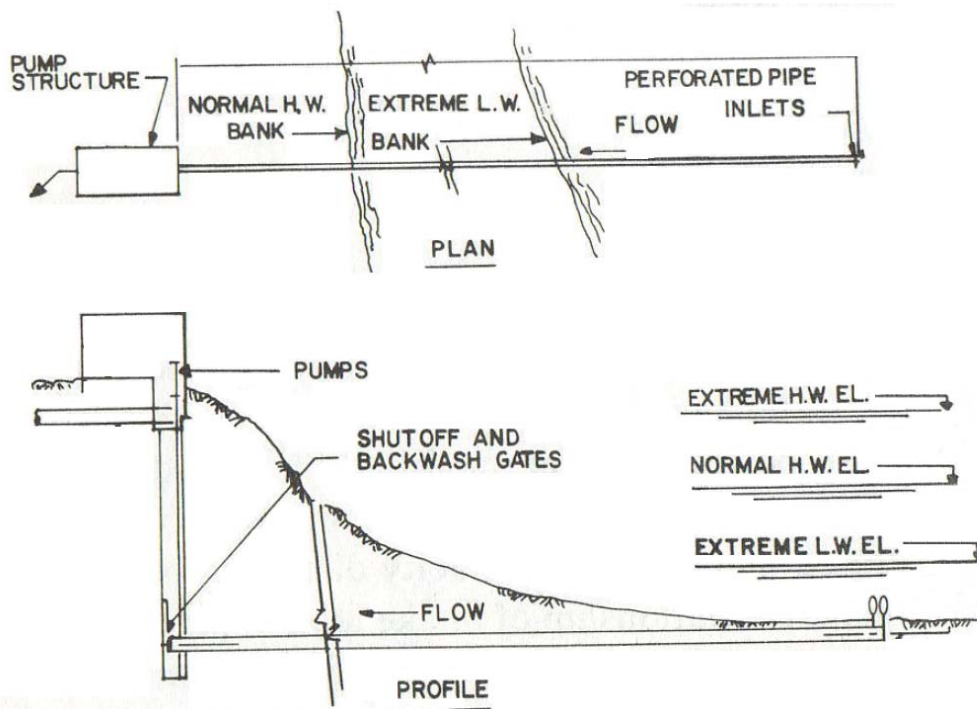

**Figure 4.13 Perforated Pipe Inlet System [Ref. 6.101]**

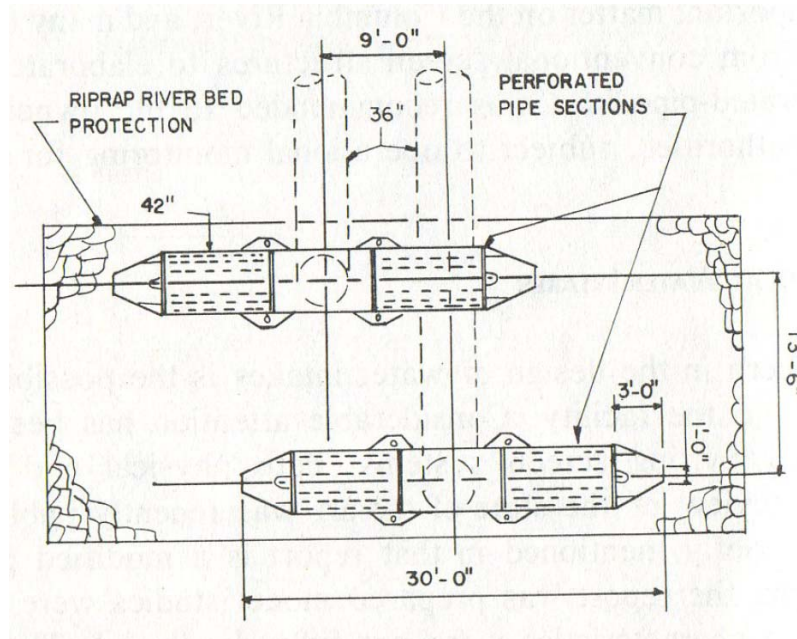

**Figure 4.14 Plan View of Perforated Pipe Inlets [Ref. 6.101]**

#### I&E Discussion

Due to the similarities between perforated pipe intakes and the wedgewire screen systems discussed in Section 4.3.1, it is expected that the I&E reductions would be similar. However, as discussed previously, perforated pipe intakes often have head loss, debris buildup, and velocity distributions issues that could attribute to increased impingement loss [Ref. 6.2].

#### Conclusions

Obsolescence of perforated pipe intakes has been caused by the development of CWW screens, which began in the late 1970s. Although perforated pipe intakes are very similar to the CWW screens discussed in Section 4.3.1, the perforated pipe openings increase the head loss across the screen face, create a poor velocity distribution, and create a surface profile prone to clogging or snagging when compared to the wedge-shaped wire screen used in CWW screens. Therefore, perforated pipe intakes are not further considered as an alternative to the existing intake technologies.

### **4.3.3 Porous Dikes/Leaky Dams**

Although the implementation of porous dikes, also known as leaky dams or leaky dikes, would be theoretically possible, porous dikes are not considered as viable alternatives to the current screening systems at the Stations due to nuclear-safety related issues with the conceptual designs and the unproven nature of this technology in front of the service water systems at nuclear generating facilities. More specifically, because the safety-related service water channels would be enclosed by any of the conceptual configurations, any reduction in void spaces within the porous dikes caused by debris, siltation, or fouling,



including by colonization of fish and plant life, combined with the lack of a back flushing system associated with these systems, could implicate nuclear-safety related issues and potential interruptions in operations due to flow reliability issues with the circulating water system.

Porous dikes are filters resembling a breakwater that surround a cooling water intake. The core of a porous dike consists of riprap stone, cobble, or gravel contained within wire-mesh cages that allow for the free passage of water through the voids or pores. Porous dikes act as behavioral and physical barriers to juvenile and adult fish, keeping them from entering a CWIS. The size of the pores in the core of the dike determines the biological effectiveness, the through-core intake velocity, and the amount of maintenance required. Although smaller pores would be expected to allow fewer fish to pass through the core of a porous dike, the through-core intake velocity would increase, as would the amount of maintenance required. Figure 4.15 shows plan and section views of a typical porous dike.

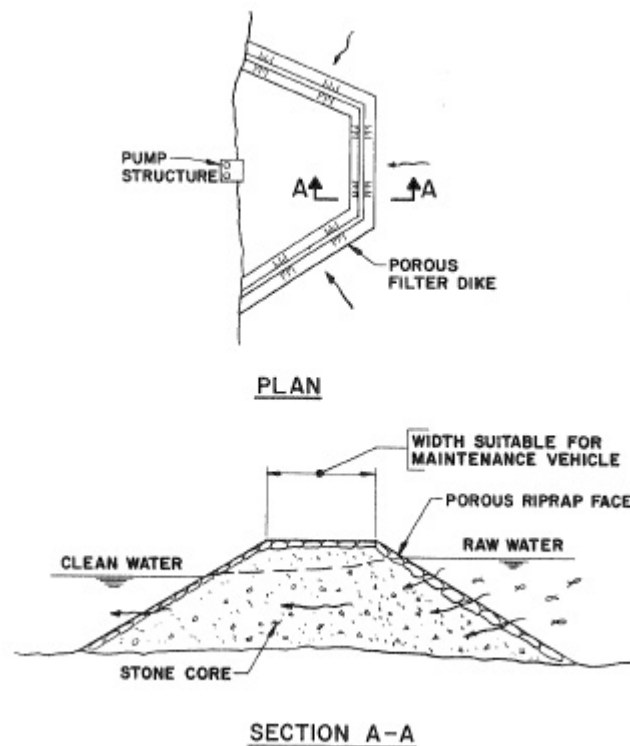

**Figure 4.15 Plan and Section View of a Porous Dike [Ref. 6.2]**

Porous dikes are typically used only for low flow rate applications, and currently no porous dike installations exist at nuclear power generating facilities or comparatively sized fossil-fuel generating facilities. The primary concern with porous dikes, particularly at nuclear facilities, is the potential for fouling. While fouling is a substantive issue for barrier and screening technologies, it is a particular issue for porous dikes, because back-flushing systems, commonly used in other screening technologies, are not feasible for porous dikes [Ref. 6.115]. Additional concerns include the buildup of ice against the porous dike walls, engineering practicality, and limitations to the recreational and nautical use of the waterway.

At nuclear facilities, any reduction in void spaces within the porous dikes caused by debris and silt and/or fouling by colonization of fish and plant life, combined with the lack of a back flushing system, could lead to an interruption of cooling water supply to nuclear-safety related systems and interruptions in the operation of the plant due to flow reliability issues with the circulating water system. The addition of this new failure mode for the SW system would affect the licensing basis of the plant and would therefore require an amendment to the Stations' NRC licenses (License Amendment). Similarly, a redesign of the SW system to avoid or mitigate new failure modes would also affect the licensing basis of the plant and would require a License Amendment.

The hydraulic and fouling characteristics of porous dikes were studied at a testing facility on the estuarine Mount Hope Bay for the Brayton Point Generating Station (BPGS), beginning in July 1979. The porous dike used for testing consisted of a reinforced concrete and steel structure with a water intake channel sectioned into three 6 ft wide and 20 ft deep sections. The first and third sections were filled with wire-mesh cages containing 3 inch stone and 8 inch stone, respectively. The center section was left open and used as a control channel. Performance of the porous dikes was characterized by an increase in head loss across the upstream and downstream faces of the test sections and a reduction in flow volume. Daily head losses were similar for the first and third sections, where increases in head loss correlated with observed fouling. The maximum reported flow rate for the first section was approximately 23 gpm/ft<sup>2</sup>, and the maximum reported flow for the third section was approximately 32 gpm/ft<sup>2</sup>. The approach velocity of the water entering the porous dike sections was consistent at approximately 0.1 fps; however, flows below 0.1 fps were obtained below the low water mark of the dikes, indicating that increased fouling occurred near the bottom. Tubes inserted into the test sections were used to measure increases in weight and biofouling, which correlated to void space reductions. Biological analysis of the fouling tubes indicated that approximately half of the accumulated materials in the porous dike sections were live organisms [Ref. 6.69]. Porous dikes were never implemented for full scale operation at BPGS.

Artificial breakwaters, which are similar in construction to porous dikes, have been shown to increase habitat for demersal fishes and invertebrates. An artificial breakwater is used to protect the ocean shoreline CWIS at the Pilgrim Nuclear Power Station (Pilgrim) in Plymouth, Massachusetts. The presence of a breakwater, like the one at Pilgrim, attracted a community of macroscopic algae, hydroids and other biofouling organisms that created a multi-tiered and diverse habitat. In turn, this diverse habitat attracted reef-dwelling fish, specifically cunner (*Tautoglabrus adspersans*). Since porous dikes are similar in construction to the breakwater at Pilgrim, they may function as artificial reefs, and – when built in ecosystems with limiting hard substrate habitat – are likely to attract a diverse community. In estuarine ecosystems, like the Hudson River Estuary, the sediment burden carried by freshwater inflow is likely to increase the potential for clogging of the pore spaces needed for porous dikes to work as they were designed [Ref. 6.76; Ref. 6.98].

For the Stations, sizing of conceptual porous dikes was estimated using a surface area of 120 ft<sup>2</sup> and the BPGS maximum flow rate of the 8 inch stone section (32 gpm/ft<sup>2</sup>) as a scaling factor. Water depths in the vicinity of the Stations' CWISs range from approximately 12 ft to 80 ft [Ref. 6.80], and, assuming an average submerged depth of 50 ft, a conceptual porous dike at Unit 2 would require a length of approximately 545 ft to

filter 870,000 gpm (design CW flow of 840,000 gpm and design SW flow of 30,000 gpm). Unit 3 would require a conceptual porous dike with a length of approximately 550 ft to filter 876,000 gpm (design CW flow of 840,000 gpm and design SW flow of 36,000 gpm). Assuming an average submerged depth of 50 ft is conservative (i.e., understates the required length), because a greater average submerged depth reduces the required length of the conceptual porous dikes. As shown in Attachment 2, Figure 2-17, the Unit 2 and Unit 3 porous dikes would extend approximately 125 ft and 75 ft, respectively, from the shoreline of the Stations into the Hudson River. The endpoints for the conceptual Unit 2 porous dike would be the existing asphalt road north of the Unit 2 CWIS and the southern end of the Unit 2 wing wall, and the endpoints for the conceptual Unit 3 porous dike would be near the southern perimeter of the condensate polishing building and the northern end of the discharge canal.

A single conceptual porous dike enclosing the CWISs for Units 2 and 3 would also include the CWIS for Unit 1 (i.e., the porous dike would also be required to filter the 16,000 gpm design flow for the Unit 1 RW pumps). In order to filter the combined flowrate of 1,762,000 gpm, a porous dike with a total length of approximately 1110 ft would be required, assuming an average submerged depth of 50 ft. As shown in Attachment 2, Figure 2-18, the single conceptual porous dike would extend approximately 105 ft into the Hudson River with a shoreline distance of approximately 900 ft. The north and south endpoints for the conceptual porous dike enclosing the CWISs for Units 2 and 3 is near the north end of the Unit 2 wing wall and south end of the Unit 3 wing wall, respectively.

#### I&E Discussion

At the Stations, a porous dike would be sized to produce a through-slot velocity at or below 0.5 fps. According to 40 CFR §125.94, if a facility reduces its through-screen velocity to at or below 0.5 fps, it is “deemed to have met the impingement mortality performance standards”. Because the effectiveness of screening early life stages by porous dikes has not been established at any site [Ref. 6.2], a study would be required to estimate the potential reductions in entrainment losses.

#### Conclusions

As shown in Attachment 2, Figures 2-17 and 2-18, the safety-related SW channels would be enclosed by either of the conceptual porous dike configurations. Therefore, any reduction in void spaces within the porous dikes caused by debris, siltation and/or fouling by colonization of fish and plant life, combined with the lack of a back flushing system associated with these systems, could implicate nuclear-safety related issues and potential interruptions in operations, due to flow reliability issues with the service water and circulating water systems. Based on these nuclear-safety related issues, the installation of porous dikes is not considered as a viable alternative to the current screening systems.

## **4.4 Barrier Technologies**

### **4.4.1 Aquatic Filter Barriers**

Although Aquatic Filter Barriers (AFBs) are theoretically feasible and have the potential to reduce I&E, certain operational issues (specifically, fouling and icing concerns) could

prohibit their operation at the Stations throughout the year. In addition, the actual design and installation of an AFB at the Stations would require extensive biological, geotechnical, and field studies to determine the optimum curtain size, perforation size, anchoring system, airburst operation schedule, and maintenance schedule. Furthermore, implementation of AFBs at the Stations would present significant nuclear safety and licensing issues (including probable License Amendments) that would need to be resolved prior to permitting of the AFBs. AFBs are not currently installed, nor have ever been licensed or installed in front of a service water intake at a nuclear facility.

The Aquatic Filter Barrier (AFB) is a relatively new technology for use at cooling water intake structures [Ref. 6.19]. The AFB is permeable to water but relatively impermeable to fish, shellfish, and ichthyoplankton, and therefore capable of reducing both I&E [Ref. 6.19]. Gunderboom® has a patented full-water-depth filter curtain, composed of polyethylene or polypropylene fabric that is supported by flotation billets at the surface of the water and anchored to the bottom of the water body. This AFB system is referred to as the Gunderboom® Marine Life Exclusion System™ (MLEST™). The MLEST™ completely surrounds the intake structure, preventing organisms from entering the cooling water intake. A deployed Gunderboom® system is shown in Figure 4.16.



**Figure 4.16 Gunderboom® MLEST™ Deployed at Lovett Generating Station**

The Gunderboom® MLEST™ is a permeable curtain typically constructed of two layers of fabric that are subdivided into vertical cells or pockets. A flotation hood keeps the system afloat and maintains complete coverage through the water column. Sufficient fabric is used to accommodate water level fluctuations [Ref. 6.99]. The fabric used to create the MLEST™ panels is shown in Figure 4.17. MLESTs™ have sizing limitations and the ability to interfere with or prevent other existing uses of the source waterbody [Ref. 6.115].

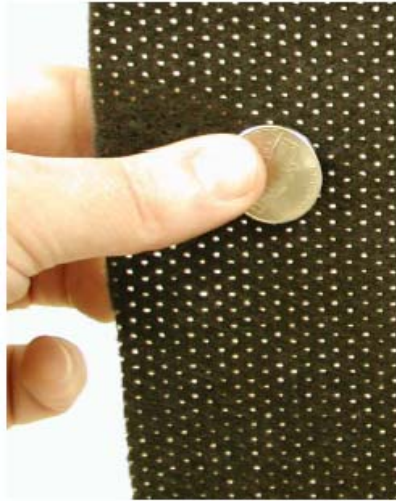

**Figure 4.17** **Gunderboom® Permeable Fabric Material [Ref. 6.19]**

A MLES™ is typically sized to allow a flowrate of 5 to 10 gpm/ft<sup>2</sup>. Loads on the curtain fabric are reduced by maintaining low through-curtain flow rates; however, low through-curtain flow rates increase the size of the MLES™ required. Conversely, high through-curtain flow rates decrease the size of the MLES™ required, but increase the possibility of curtain failure due to debris loading.

The MLES™ utilizes AirBurst™ systems to routinely remove deposits on the fabric panels. The AirBurst™ system consists of tubing woven into the bottom of each Gunderboom® panel that releases compressed air to dislodge debris attached to the panels. Where available, a sweeping velocity in a waterway can carry dislodged debris away from the MLES™. Laboratory tests conducted by EPRI concluded that the AirBurst™ system effectively cleaned various AFB configurations in one to three cleaning cycles under certain circumstances [Ref. 6.19].

According to the EPA's Technical Development Document for the Final Section 316(b) Phase II Rule, AFBs are "experimental in nature," and Lovett Generating Station (a coal-fired plant) was the only power plant facility where an AFB has been used at a full scale level [Ref. 6.115]. A MLES™ was deployed from 2004 through 2008 at Units 3, 4, and 5 of Lovett Generating Station, a now retired power plant located approximately 1.5 miles southwest of IPEC on the western shoreline of the Hudson River in Stony Point, NY. Units 3, 4, and 5 of Lovett Generating Station had a combined condenser cooling water intake rate of approximately 323,000 gpm (465 MGD) [Ref. 6.99]. Field and laboratory studies conducted from 1995 through 2001 were performed to develop and evaluate a MLES™ at Lovett Generating Station, prior to installation of a fully operational MLES™ in 2004 [Ref. 6.72; Ref. 6.73; Ref. 6.74]. Significant conclusions from these studies included:

- Anchoring systems for the MLES™ must be properly engineered through bathymetric and geophysical studies of the waterway to prevent detachment of the anchors caused by debris loading on the MLES™ fabric [Ref. 6.72].

- Perforation size in the MLEST<sup>TM</sup> fabric is site specific and is driven by biological exclusion requirements, waterbody characteristics, and flow requirements [Ref. 6.19; Ref. 6.72].
- AirBurst<sup>TM</sup> systems must be utilized to remove debris and sediment buildup on the face of the MLEST<sup>TM</sup> fabric. Frequency of airburst operation is site specific depending on debris loading characteristics. Inadequate removal of debris from the MLEST<sup>TM</sup> results in submergence or overtopping of flotation billets [Ref. 6.73].
- Fabrication of the MLEST<sup>TM</sup> curtain needs to conform precisely to the maximum water depths along the deployment transect to ensure effective cleaning and limit the potential for biofouling growth [Ref. 6.74].
- Flow rates through the MLEST<sup>TM</sup> curtain should be between 5 and 10 gpm/ft<sup>2</sup>. Laboratory tests conducted in 1997 indicated that curtain fabrics tested at flow rates of approximately 5 gpm/ft<sup>2</sup> clogged slowly, but recovered well after cleaning. Curtain fabrics tested at flow rates of approximately 10 gpm/ft<sup>2</sup> clogged faster and the recovery rate after clogging was acceptable, but not as good as with flow rates of approximately 5 gpm/ft<sup>2</sup>. Curtain fabrics tested with flow rates in the range of 15 gpm/ft<sup>2</sup> clogged rapidly with poor flow rate recovery after cleaning [Ref. 6.73].

As noted in Attachment 6, the MLEST<sup>TM</sup> at Lovett Generating Station had a 79% overall average exclusion effectiveness. According to Attachment 6, this effectiveness, and the absence of size selectivity, both suggest that performance of the MLEST<sup>TM</sup> at Lovett Generating Station was directly related to its time of deployment with respect to the Hudson River fish spawning season, the proportion of the total intake flow drawn directly through the filtration mesh, and the density of ichthyoplankton in the volume of unfiltered water drawn into the intake when deployment fails. In addition, post-deployment inspections at Lovett Generating Station identified tears in the flotation billet collars, due to extensive flexing caused by tidal oscillations and tears in the MLEST<sup>TM</sup> curtain fabric near airburst diffusers caused by entanglement with anchor lines or other structures [Ref. 6.74]. IPEC is located on the Hudson River approximately 1.5 miles from Lovett Generating Station and, as discussed in Attachment 6, both Lovett Generating Station and IPEC are exposed to the same source water body population of ichthyoplankton during the same seasonal cycle and are likely to experience similar entrainment through an MLEST<sup>TM</sup>. However, the MLEST<sup>TM</sup> at Lovett Generating Station varied in depth from 20 to 35 ft deep, while an MLEST<sup>TM</sup> at IPEC would have an average depth of approximately 50 ft. Therefore, it is the increased depth and associated stresses at IPEC would likely increase the occurrence and severity of tears in the flotation billet collars or the MLEST<sup>TM</sup> curtain fabric, anchorage issues, and fouling/over-topping events.

Individual MLESTs<sup>TM</sup> for IPEC Units 2 and 3 were conceptualized using the upper limit of the recommended flow range, 10 gpm/ft<sup>2</sup>, and the midpoint of the recommended flow range, 7.5 gpm/ft<sup>2</sup>. Individual MLESTs<sup>TM</sup> using the lower limit of the recommended flow range, 5 gpm/ft<sup>2</sup>, were not considered, because the dimensions of the MLESTs<sup>TM</sup> required would extend outside of IPEC's existing exclusion zone, further limiting navigability of the River. Using the upper limit of the recommended through-curtain flow rates to

conceptualize MLESs™ at Units 2 and 3 illustrates the minimum MLES™ dimensions required, while using the midpoint of the recommended through-curtain flow illustrates more conservative dimensions of MLESs™. It is not likely that any MLES™ at the Stations would be designed using the upper limit of the recommended through-curtain flow rates, because some margin of increased filtration area would be desired to ensure reliable operation of the system during periods of heavy debris loads. A site-specific study at the Stations would be required to determine this margin.

The required square footage of the curtain fabric and overall length of the conceptual MLES™ for each of these flow rates are shown in Table 4.5 and assume an average submerged depth of 50 ft. Water depths in the vicinity of the Stations' CWISs range from approximately 12 ft to 80 ft [Ref. 6.80]. Assuming an average submerged depth of 50 ft is conservative, because a greater average submerged depth reduces the required length of the conceptual MLESs™.

**Table 4.5 Conceptual MLES™ Areas and Lengths**

Design Parameter	Unit 2		Unit 3	
CWIS Flow Rate (gpm)	870,000		876,000	
Through-Curtain Flow Rate (gpm/ft <sup>2</sup> )	7.5	10	7.5	10
Curtain Fabric Area (ft <sup>2</sup> )	116,000	87,000	116,800	87,600
Overall length of MLES™ (ft)	2,320	1,740	2,340	1,750

As shown in Attachment 2, Figures 2-7 and 2-8, the shoreline endpoints for a conceptual MLES™ at each Unit were selected to avoid interferences with existing structures (i.e., the condensate polishing building and Unit 1 wharf) and to remain within the boundaries of the existing exclusion zone. Additionally, the southern endpoint of the conceptual MLES™ for Unit 3 was placed away from the southern end of the discharge canal to avoid recirculation of debris in the discharge cooling water.

A combined MLES™ enclosing the CWISs for Units 2 and 3 would also include the CWIS for Unit 1. In order to filter the combined flowrate of 1,762,000 gpm, an AFB with an overall length of approximately 3525 ft would be required based on the upper limit of the recommended flow rate through the curtain fabric of 10 gpm/ft<sup>2</sup> and an average submerged depth of 50 ft. This conceptual combined MLES™ for Units 2 and 3 would extend approximately 900 ft into the Hudson River based on a shoreline distance of approximately 1800 ft and would occupy nearly all of the exclusion zone. A combined MLES™ enclosing the CWISs of Units 1, 2, and 3 with a through-curtain flow rate at the midpoint of the recommended flow rate of 7.5 gpm/ft<sup>2</sup> would require an overall length of approximately 4700 ft, assuming an average submerged depth of 50 ft, and would not fit into the existing exclusion zone. The dimensions of a combined MLES™ are larger than the dimensions of the individual MLESs™ and a combined MLES™ likely to be installed (through-curtain flow rate of 7.5 gpm/ft<sup>2</sup>) would not fit in the existing exclusion zone. Additionally, a combined MLES™ would preclude the use of the Unit 1 wharf that is required for nautical plant security responses. Thus, a single combined MLES™ for both Units would provide no additional benefits to the individual MLESs™ for Units 2 and 3 shown in Attachment 2, and is not further considered as an alternative to the existing intake screening systems.

Actual design and installation of an AFB at the Stations would require extensive biological, geotechnical, and field studies to determine the optimum curtain size, perforation size, anchoring system, airburst operation schedule, and maintenance schedule. As noted by EPRI in its laboratory study, the potential biological effectiveness of an AFB is related to the ability of the curtain material to be maintained in position with adequate control of debris [Ref. 6.19]. Site-specific developmental studies would be required at IPEC, similar to those performed at Lovett Generating Station between 1995 and 2001, to achieve the requisite level of certainty. Furthermore, MLESs™ are susceptible to damage and clogging due to ice formation on the curtain fabric during the winter months [Ref. 6.94]. As such, the use of any MLES™ installed would be limited to seasonal deployment, because mechanisms do not currently exist to heat the curtain fabric or otherwise prevent damage due to icing. Because IPEC is located on the shore of the Hudson River, any potential MLES™ would be situated in the main channel of the waterway exposing it to large floating or submerged debris that could cause tearing, entanglement, or overtopping of the MLES™. The potential for failure or extensive damage to the MLES™ curtain fabric due to large debris would also have to be evaluated prior to implementation.

An extensive anchoring system is required to secure the curtain fabric in place and to ensure that unfiltered water does not enter the intake area below the curtain fabric. The MLES™ installed at Lovett Generating Station had a length of approximately 1500 ft and was secured in place by 123 concrete anchors [Ref. 6.3]. Each concrete anchor was 6 ft long, 3 ft wide, and 3 ft tall (54 cubic feet) [Ref. 6.73]. The concrete anchor volume corresponds to an approximate weight of 8100 pounds per anchor. The combined length of the conceptual MLESs™ at Units 2 and 3 with a through-curtain flow rate of 10 gpm/ft<sup>2</sup> would be approximately 3525 ft. Scaling from the Lovett Generating Station system, at least 287 concrete anchors would be required at IPEC to secure the curtain fabric to the floor of the Hudson River.

The primary concern with installation of an AFB is the potential for the curtain fabric to detach from its anchors and block the CWIS. The conceptual MLES™ configurations shown in Attachment 2 Figures 2-7 and 2-8 would enclose the safety-related SW intake channels. Detachment of the MLES™ curtain fabric from its anchors could allow the curtain fabric to be drawn into the CWIS, potentially clogging the SW intake channels and cutting off the SW supply required for safe shutdown of the plant. In order for a MLES™ to be considered for deployment at a nuclear power plant, extensive testing and qualification of the MLES™ materials, specifically the attachments to the anchorages, would be required prior to the completion of a comprehensive failure modes and effects analysis (FMEA). Following this analysis, the NRC would require the submittal of a License Amendment Request (LAR) detailing the changes from the existing plant configuration and analysis and indicating that the ability of the plant to achieve safe shutdown would not be negatively affected by implementation of the MLES™. Approval of the LAR by the NRC would be required prior to implementation of the MLES™. It is not likely that the NRC would approve a LAR of this type, because both NRC requirements and the Institute of Nuclear Power Operations (INPO) guidelines prohibit screen systems that may compromise the ultimate heat sink or otherwise impair water-based nuclear safety-related systems [Ref. 6.67].



Units 2 and 3 each have backup sources of cooling water flow for the SW systems that could provide SW to each Unit in the event of a blockage of the SW intake channels caused by a detached MLES<sup>TM</sup>. The Unit 1 RW pump can provide cooling water flow to the Unit 2 SW system via crossover piping and Unit 3 is equipped with three 5000 gpm backup SW pumps that take suction from the Unit 2 discharge canal. Extensive analysis of the suitability of each of these backup pumps would be required prior to the implementation of MLESs<sup>TM</sup>, because the backup pumps are not qualified for safety-related operation, and only two of the three Unit 3 backup SW pumps can currently be powered by the emergency diesel power generators [Ref. 6.64]. It is possible that the conceptual MLESs<sup>TM</sup> at Unit 2 shown in Attachment 2 Figures 2-7 and 2-8 could fail in a manner that would block the intake structures of both Units 1 and 2, precluding flow from the Unit 1 RW pump and Unit 2 SW pumps. Based on this scenario, the potential installation of new backup SW pumps in the Unit 2 discharge canal that could provide emergency cooling water flow for the SW system of Unit 2 would need to be determined prior to the implementation of MLESs<sup>TM</sup> at IPEC. Any redesign of the SW system to avoid or mitigate any new failure modes associated with the implementation of an MLES<sup>TM</sup> at either Unit would also affect the licensing basis and would require a License Amendment, as discussed previously.

#### Maintenance

MLESs<sup>TM</sup> are passive barrier systems with few mechanical components; thus, periodic inspection and cleaning would entail the majority of the maintenance scope. However, MLESs<sup>TM</sup> would require seasonal installation, retrieval, and subsequent repair to the curtain fabric adding to the overall maintenance cost. As noted previously, at Lovett Generating Station, tears in the flotation billet collars due to extensive flexing caused by tidal oscillations and tears in the MLES<sup>TM</sup> curtain fabric near airburst diffusers caused by entanglement with anchor lines or other structures were identified during post-deployment inspections [Ref. 6.74]. The small apparent opening size of the curtain fabric material required to physically exclude eggs and larvae also retains higher debris loads and dictates that the MLESs<sup>TM</sup> be inspected in frequent intervals. When MLESs<sup>TM</sup> are initially installed they should be inspected on a quarterly basis for the first 12 to 15 months of operation to monitor fouling/growth. The conditions of MLESs<sup>TM</sup> should be well documented so that fouling/growth can be closely monitored. Once the rate of fouling has been established, the inspection frequency may be altered to coincide with the fouling rate.

The evaluated AFBs / MLESs<sup>TM</sup> would have several operations and maintenance (O&M) requirements as detailed below:

- Check air cleaning systems via boat
- Clean MLESs<sup>TM</sup> using power wash system via boat deployment
- Annual deployment of MLESs<sup>TM</sup>
- Annual retrieval of MLESs<sup>TM</sup>
- Inspect MLESs<sup>TM</sup> while deployed in River
- Repair MLESs<sup>TM</sup> after removal from River

The O&M estimates for the MLESs™ are in addition to the present O&M requirements for the existing TWSs that would operate when the MLESs™ were not deployed. When debris accumulates on the MLESs™ fabric, the MLESs™ would be cleaned with an AirBurst™ system. The frequency of cleaning would need to be determined by operations after installation in order to account for conditions specific to the Hudson River.

Operations personnel would likely perform O&M activities associated with maintenance of the AirBurst™ systems and cleaning of the MLES™; however, deployment and retrieval of the MLESs™, underwater inspection of the MLESs™, and repair of the MLESs™ would likely be performed by teams of divers and specialists contracted through Gunderboom®. The minimum annual O&M cost for the evaluated MLESs™ is estimated to be approximately \$3,000,000.

Additionally, parasitic power losses would exist due to the operation of air compressor motors for the AirBurst™ systems. The estimated power requirements are based on six 200 hp motors operating 4 hours per day for 24 weeks. The 24 week estimate of the operational period of the AirBurst™ system motors is a conservative estimate of the time period that MLESs™ could be deployed without being significantly affected by icing or fouling and corresponds to the months of May through October. Based on these assumptions, the additional parasitic losses associated with operation of the air compressor motors for the airburst systems would be approximately 601 MW-hr per year.

#### Cost

The capital cost estimates for implementation of the evaluated MLESs™ are detailed in Attachment 4 and include design, procurement, implementation, and startup activities, based on the conceptual design shown in Attachment 2 Figure 2-8. The costs associated with permitting the MLESs™ are not included in this estimate. As shown in Attachment 4, the total estimated capital cost for MLESs™ at the Stations would be approximately \$67.4 million. In order to avoid interfering with normal operations, the installation of the anchoring systems for the MLESs™ would be recommended, but not required, to coincide with scheduled outages. As noted previously, the O&M and seasonal deployment, removal, and repair of the MLESs™ would cost, at a minimum, approximately \$3 million annually, not including the O&M costs for the existing CWISs.

#### I&E Discussion

Attachment 6 (Tables 17 and 23 of Appendix A) provides the estimated reductions from the regulatory baseline in EA1 I&E that could be achieved through the seasonal use of MLESs™ accounting for the Stations' survival rates (Attachment 6) and average historic flow reductions (Section 2.4.2.3.2). A summary of the information included in the tables is shown in Table 4.6. Note that the maximum possible reductions in EA1 I&E shown in Table 4.6 (90.4% and 90.2%, respectively) are substantially higher than the current EA1 I&E reductions (80.2% and 33.8%, respectively) shown in Section 3.2.

**Table 4.6 Potential Reduction in EA1 I&E due to the Installation of MLESs™**

Month	EA1 Entrainment Loss Reduction	EA1 Impingement Loss Reduction
January	0.0%	8.7%
February	0.0%	9.6%
March	0.0%	12.0%
April	0.4%	6.6%
May	9.9%	9.5%
June	30.2%	11.7%
July	25.1%	5.3%
August	13.8%	5.5%
September	6.0%	5.7%
October	4.8%	4.9%
November	0.0%	4.6%
December	0.0%	6.3%
Annual	90.2%	90.4%

Note: In order to avoid the months in which MLESs™ would be significantly affected by icing or fouling, the MLESs™ would be deployed seasonally from May through October. Therefore, the reductions presented for the months of November through April (shaded cells) indicate the reductions due to the existing TWSs and fish return systems.

### Conclusions

Although MLESs™ have the potential to reduce I&E, there are several operational issues (i.e., fouling and icing concerns) that could prohibit the operation of the AFBs throughout the year. Implementation of MLESs™ at the Stations would present significant nuclear safety and licensing issues (including possible License Amendments) that would need to be resolved prior to permitting of the AFBs. Consistent with the aforementioned conclusion, AFBs are not currently installed, nor have ever been licensed or installed in front of a service water intake at a nuclear facility. In addition, the actual design and installation of an AFB at the Stations would require extensive biological, geotechnical, and field studies to determine the optimum curtain size, perforation size, anchoring system, airburst operation schedule, and maintenance schedule.

#### **4.4.2 Fish Barrier Nets**

Fish barrier nets are not considered as viable alternatives to the current screening systems at Units 2 and 3 due to nuclear-safety related issues and the lack of comparable reductions in I&E to the NYSDEC Proposed Project or other alternative technologies. In addition, fish barrier nets have not been successfully implemented for protection of eggs or larvae and, therefore, would not be expected to provide significant reductions in entrainment

Fish barrier nets are coarse-mesh nets that are installed in front of the entrance to an intake structure primarily to reduce impingement of fish [Ref. 6.2; Ref. 6.16]. The size of the mesh openings limits the size of the organisms that can pass through the net. Although

finer meshes can be used to reduce entrainment of smaller species and juvenile fish, the larger mesh sizes are generally required to maintain low through-screen velocities (usually at or below 0.5 fps) and avoid excessive clogging [Ref. 6.2; Ref. 6.16]. Barrier nets with mesh fine enough to prevent entrainment of eggs and larvae have not been successfully deployed due to the challenges of keeping the mesh clean of silt and biofouling [Ref. 6.16]. Therefore, fish barrier nets are not considered an effective technology for reducing entrainment of eggs, larvae, or zooplankton [Ref. 6.2; Ref. 6.16].

Cooling water is drawn through the openings in the mesh before entering the plant intake. Several installation designs have been developed to accommodate a range of operating conditions. The rigid panel support system shown in Figure 4.18 is typical for large installations with high debris loading and/or biofouling and high ambient velocity conditions on large estuaries, such as at the Hudson River in front of the Stations [Ref. 6.16].

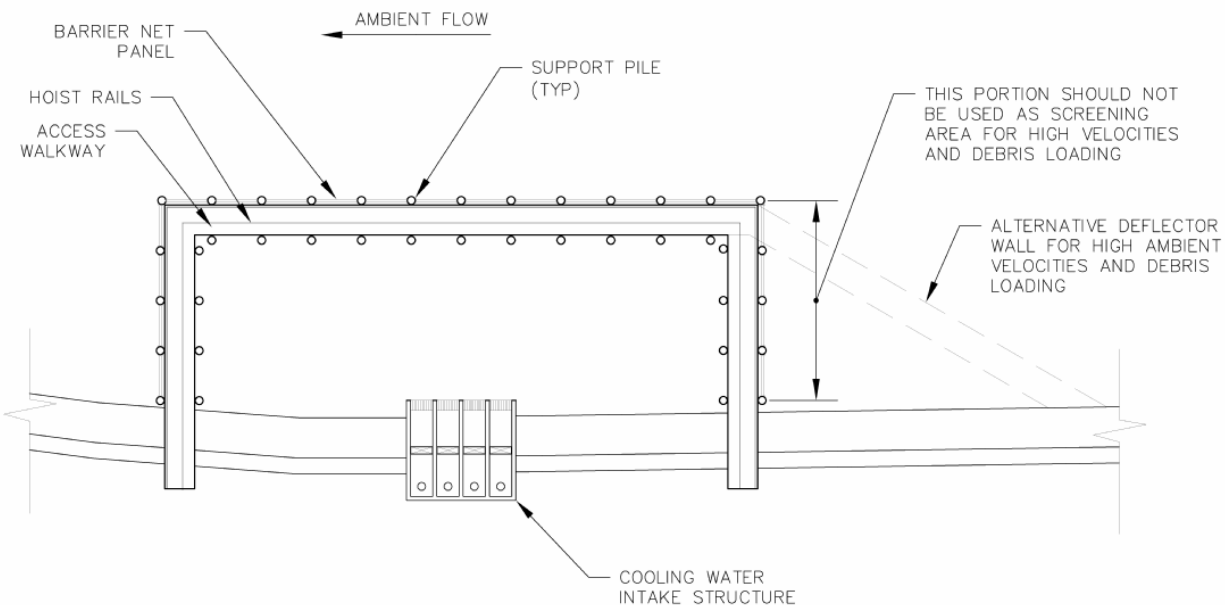

**Figure 4.18 Fixed Panel Standard Design Plan [Ref. 6.16]**

In a rigid net panel design, the net is supported by steel piles, sheet pile cells, and sheet pile isolation walls, as shown in Figure 4.19. A walkway deck typically spans the length of the net to facilitate cleaning and maintenance. Individual net panels are hoisted to the walkway level for cleaning with power sprays and brushes. Uninterrupted fish protection can be provided by using spare net panels lowered into place during cleaning.

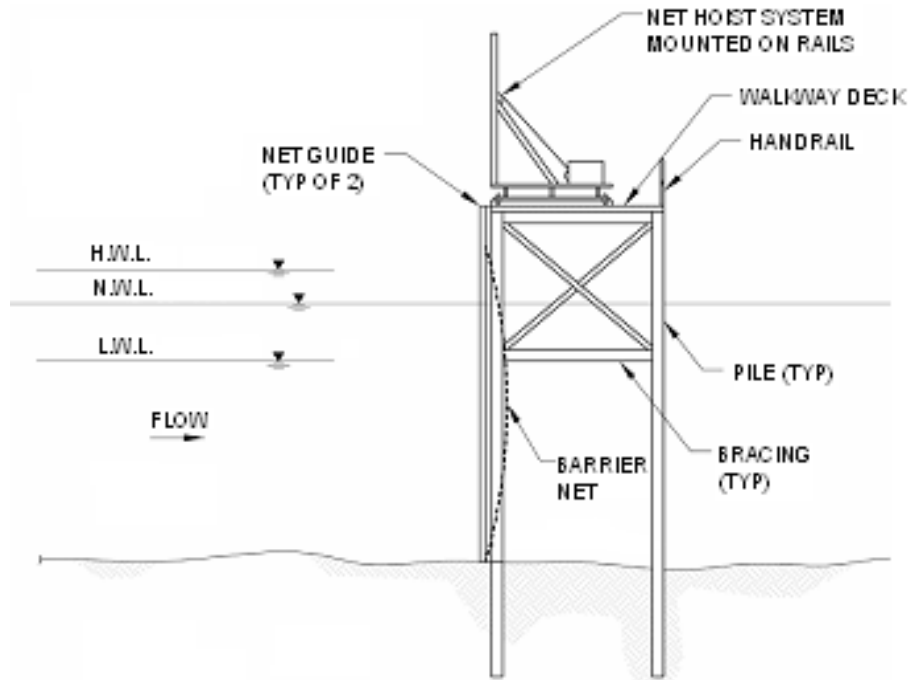

**Figure 4.19 Rigid Panel Support Design [Ref. 6.16]**

Fish barrier nets have been deployed at several large power plants. The mesh sizes (measured by the length of one of the four sides of the net opening) for these installations have ranged from  $\frac{1}{10}$  to 1- $\frac{1}{4}$  inch [Ref. 6.16]. Typical barrier net mesh sizes are  $\frac{1}{4}$ -,  $\frac{3}{8}$ -, and  $\frac{1}{2}$ -inch. As discussed in Section 2.4.1.1, the existing traveling water screens at the Stations have a mesh size of  $\frac{1}{4}$ -inch wide by  $\frac{1}{2}$ -inch tall.

Failure of a fish barrier net could present serious operational and, where applicable, nuclear safety concerns. At Detroit Edison's Monroe Plant, a fish barrier net placed across the intake canal clogged with fish and collapsed. The net failure was attributed to high intake velocities greater than 1.3 fps [Ref. 6.2]. A fish barrier net is deployed seasonally to reduce impingement at Arkansas Nuclear One (ANO), owned and operated by Entergy Arkansas, Inc. [Ref. 6.16]. The fish barrier net at ANO is installed outside an intake canal in the Lake Dardanelle reservoir and is deployed in the winter. The net material is nylon with mesh sizes of  $\frac{3}{8}$  and  $\frac{1}{2}$  inch and through-net velocities of approximately 0.04 ft/s. At ANO, emergency SW is supplied by an emergency cooling pond through a channel separate from the circulating water intake, eliminating this safety concern [Ref. 6.23].

A fish barrier net at the Stations would be designed for lower velocities than Detroit Edison's Monroe Plant, but excessive fouling and/or River flow variability at the site could cause a similar failure. As described in Section 2.4.1, the SW pump channel for each Unit has three CW pump channels located on each side. Collapse of a fish barrier net installed in front of the CW pump channels could clog the SW intake channels, cutting off the SW supply required for safe shutdown of each Unit. Both NRC requirements and INPO guidelines prohibit screen systems that could compromise the ultimate heat sink or otherwise impair water-based nuclear safety-related systems [Ref. 6.67]. Based on this

nuclear-safety related issue, the installation of a single barrier net spanning both intakes or one barrier net at each CWIS is not considered a technologically feasible means of reducing I&E. Placement of four smaller nets for each set of three CW pumps on either side of the SW channels could be possible, although the potential for net failure to affect SW pump operation could still exist. The addition of a new failure mode for the SW system would affect the licensing basis of the plant and would therefore require a License Amendment. Similarly, a redesign of the SW system to avoid or mitigate new failure modes would also affect the licensing basis of the plant and would require a License Amendment.

#### I&E Discussion

As noted in Section 3.2, the Stations' existing TWSs screens and fish return systems already provide state-of-the-art impingement protection. Therefore, it is not expected that implementation of fish barrier nets would be able to provide significant reductions in impingement. In addition, fish barrier nets have not been successfully implemented for protection of eggs or larvae and, therefore, would not be expected to provide significant reductions in entrainment [Ref. 6.2].

#### Conclusions

In addition to the nuclear-safety related issues associated with the installation of fish barrier nets at the Stations, fish barrier nets have not been successfully implemented for protection of eggs or larvae and, therefore, would not be expected to provide significant reductions in entrainment [Ref. 6.2]. There would be a potential for some additional impingement reductions with the implementation of fish barrier nets; however, due to the lack of significant entrainment reductions and the nuclear-safety related issues, fish barrier nets are not further considered as alternatives to the current intake screening systems.

### **4.4.3 Behavioral Barriers**

None of the behavioral barriers evaluated (light guidance systems, acoustic deterrents, air bubble curtains, or electrical barriers) are considered as viable alternatives to the current screening systems at the Stations because these technologies would not be expected to provide comparable reductions in I&E to the NYSDEC Proposed Project or other alternative technologies. Because eggs and larvae cannot respond to the stimuli created by behavioral barrier systems, there would be no direct reduction in entrainment. Additional site-specific studies would be required to fully evaluate the effectiveness of any behavioral barrier systems at the Stations.

Behavioral barriers deter fish from entering CWISs by utilizing their natural behavioral responses to external stimuli. In general, studies of behavioral barriers have been inconclusive or have shown no significant reduction in I&E across species [Ref. 6.2], but such systems have proved effective for certain species, because behavioral barrier performance is highly dependent on the CWIS site characteristics and fish species present [Ref. 6.2]. Consequently, there are multiple acoustic fish deterrence systems operating at power generation facilities, including the NYSDEC-authorized system at the James A. FitzPatrick Nuclear Power Plant. Therefore, the biological benefit provided by a specific behavioral barrier technology cannot be fully evaluated without conducting extensive field

and biological studies at IPEC to characterize the site conditions and the response of the fish species present.

#### **4.4.3.1 Light Guidance System**

Light guidance systems are not considered as viable alternatives to the current screening systems at the Stations because they are not expected to provide reductions in I&E comparable to the NYSDEC Proposed Project or other alternative technologies.

Light guidance systems most commonly use xenon strobe lights or mercury lights to attract or repel fish. Mercury lights are typically used to attract fish; therefore, there have been very few studies performed in the application of mercury lights for avoidance purposes. Xenon strobe lights have been proven to be more effective at repelling fish than a continuous light and are the primary light guidance technology [Ref. 6.15]. In order to evaluate the behavioral response of a fish to light, three key factors must be considered: (1) fish species, (2) developmental stage of the fish, and (3) the level of adaptation [Ref. 6.28]. These factors have led to large variations in fish response to light. Low intensity light attracts certain fish species but repels others and high intensity light has shown the same pattern [Ref. 6.2]. Some species have shown no response to any type of light stimuli. Studies have shown inconsistency in the use of xenon strobe lights to reduce fish impingement and entrainment in CWISs [Ref. 6.15].

An investigation into the effectiveness of light deterrents using the Fish Avoidance Xenon System (FAXS) supplied by EG&G Electro-Optics was conducted at Roseton Generating Station on the lower Hudson River in 1986 and 1987 [Ref. 6.17]. The strobe light source was provided by a FA-125 power supply in conjunction with a FA-107 flash head. FAXS has multiple power settings which can be calibrated to provide the greatest fish deterrence. The lowest setting results in a 750 candela (cd) light output that can operate at a flash rate between 100 flashes per minute (fpm) to 600 fpm. The highest power setting results in a 4500 cd light output that can operate at a flash rate between 100 fpm to 400 fpm. FAXS provided the greatest fish avoidance when operated at a light intensity of 4500 cd and a flash rate of 200 fpm. The investigation concluded that the effectiveness of light deterrents is highly dependent on the species and time of the day [Ref. 6.17]. Results of the investigation showed that FAXS successfully deterred white perch, but was unsuccessful at deterring alewife, American shad, blueback herring, and bay anchovy. Increases in turbidity led to increases in fish avoidance due to more scattering of light [Ref. 6.17].

Flash Technology Corporation (FTC) designed a light guidance system that succeeded the EG&G's FAXS. FTC's system, specifically designed for underwater use, was the mostly commonly used light guidance technology between 1997 and 2004 [Ref. 6.15]. Although FTC's light guidance system is no longer in production [Ref. 6.30], the FTC strobe lights were capable of operating at depths of up to 80 meters and consisted of flash heads, wiring, power supplies, and a control system. Experimental results of FTC's system showed inconsistencies similar to those identified with FAXS.

## Conclusions

Many of the species present in the vicinity of Roseton Generating Station are present at the IPEC Unit 2 and 3 CWISs. However, species are only one relevant factor in effectiveness; the different locations of the Roseton and IPEC Unit 2 and 3 CWISs on the Hudson River could cause significant variations in the diversion effectiveness of a light guidance system. Therefore, site specific studies would be required to fully evaluate the diversion effectiveness of a light guidance system. As such, light guidance systems are anticipated to provide inconsistent reductions in impingement. Moreover, eggs and larvae cannot respond to the stimuli created by light guidance systems there would be no direct reduction in entrainment. For these reasons, light guidance systems are not expected to provide significant reductions in I&E and are not further considered as alternatives to the current CWIS technologies.

### **4.4.3.2 Acoustic Deterrents**

Acoustic deterrents are not considered as viable alternatives to the current screening systems at the Stations because they are not expected to provide reductions in I&E comparable to the NYSDEC Proposed Project or other alternative technologies.

Acoustic deterrents divert fish from CWISs by creating underwater sound waves that trigger an avoidance response. Fish have shown sudden bursts of speed and direction changes in response to certain sound frequencies and sound pressure levels [Ref. 6.28]. Sound waves can attract or repel fish from the acoustic source, and the behavioral response of a fish to a given frequency is dependent on various factors, including species and size [Ref. 6.28].

A study evaluating the effectiveness of acoustic deterrents called pneumatic poppers or “air poppers” was conducted at the Stations from July 20, 1985 to December 29, 1985 [Ref. 6.79]. The IPEC study was modeled after a similar study performed by Ontario Hydro that showed success in deterring yellow perch and alewife from the CWIS. As part of the study, four air poppers were installed around one of the Unit 2 intake channels. Air poppers release pressurized air into water to create a low frequency, high amplitude sound wave. Air pressurized to 3000 psig was released at 5 second intervals from the air poppers. The air poppers were active for 48 or 72 hour periods, followed by 48 hour periods of inactivity. The results of IPEC’s study showed that the air poppers had no significant impact on the numbers or species of fish in the vicinity of the intake or impinged by the CWIS [Ref. 6.79].

Acoustic deterrents were specifically evaluated for striped bass, white perch, and tomcod at the Stations [Ref. 6.21], leading to the development and testing of the Sonalysts, Inc. FishStartle™ system at the James A. FitzPatrick (JAF) Nuclear Power Plant. The FishStartle™ system is currently in operation at JAF and is similar to the SPA system (discussed below) in that it is capable at operating at a range of frequencies. At JAF, the FishStartle™ system was shown to substantially reduce the fish density in the vicinity of the intake when compared to the periods when the FishStartle™ system was not operating [Ref. 6.10]. However, because the site-specific feasibility of any acoustic deterrent system is highly dependent on the impinged species and their contribution to historical impingement, as well as their response to sound, and the engineering



constraints associated with the aquatic environment, extensive further study would be required to ascertain the biological benefits at IPEC Units 2 and 3.

Other hydroacoustic technology has been more successful at deterring fish from CWISs than air poppers. Fish Guidance Systems, Inc. has developed the Sound Projector Array (SPA) System that creates patterns of wave forms with a range of frequencies and sound pressure levels. The SPA System utilizes signal generators to send recorded signals through amplifiers that power underwater sound projectors. An acoustic modeling program called PrISM determines the number, location, and orientation of the sound projectors. PrISM predicts the particle movement field and accounts for important factors, such as the geometry of the intake, reflections, and potential destructive interference [Ref. 6.29]. The signal generators can produce multiple signals to reduce the chance of fish adaption to the sound. Nuclear Plant Doel (NPD), located on the Scheldt Estuary in Belgium, has conducted a study of the SPA System [Ref. 6.78]. The SPA system at NPD utilized a signal generator programmed with eight different signals connected to twenty 600 watt sound projectors. The sound was emitted in intervals of 0.2 seconds and ranged in frequency from 20 Hz to 600 Hz at a sound pressure level of 174 dB. The study also evaluated the effects of temperature and salinity changes in combination with the acoustic deterrents. Results of the study showed a reduction in total fish impingement of 59.6%. Reductions in the numbers of impinged gobies accounted for 78% of the total impingement reduction [Ref. 6.78]. Other species that showed significant reductions in impingement were herring, sprat, white bream, smelt, bass, perch, sole, and flounder. The reduction in herring impingement averaged 94.7% [Ref. 6.78]. The study also determined that changes in temperature and salinity can lead to changes in the acoustic field generated by the SPA system; however, these changes were found to be insignificant [Ref. 6.78]. These SPA system results are extremely site- and species-specific and are not necessarily representative of the reductions that would be expected at the Stations.

### Conclusions

Acoustic deterrent systems have been proven effective for certain sites with specific fish species. However, potential effectiveness of an acoustic deterrent system is highly species-specific [Ref. 6.2]. As such, site-specific studies would be required to fully evaluate the effectiveness of any acoustic deterrent system at the Stations. In addition, because eggs and larvae cannot respond to the stimuli created by acoustic deterrent systems there would be no direct reduction in entrainment. For these reasons, acoustic deterrent systems are not expected to provide significant biological benefits and are not further considered as alternatives to the current CWIS technologies.

#### **4.4.3.3 Air Bubble Curtains**

Air bubble curtains are not considered as viable alternatives to the current screening systems at the Stations because they were previously used at the Stations and were determined to be ineffective.

Air bubble curtains are designed primarily to create a visual deterrent to fish, but can also stimulate auditory and physical responses [Ref. 6.18]. The air bubble curtains are created by pumping air through a diffuser hose. As shown in Figure 4.20, nozzles in the diffuser

hose release a dense “wall” of air bubbles that deter juvenile and adult fish from the CWIS.

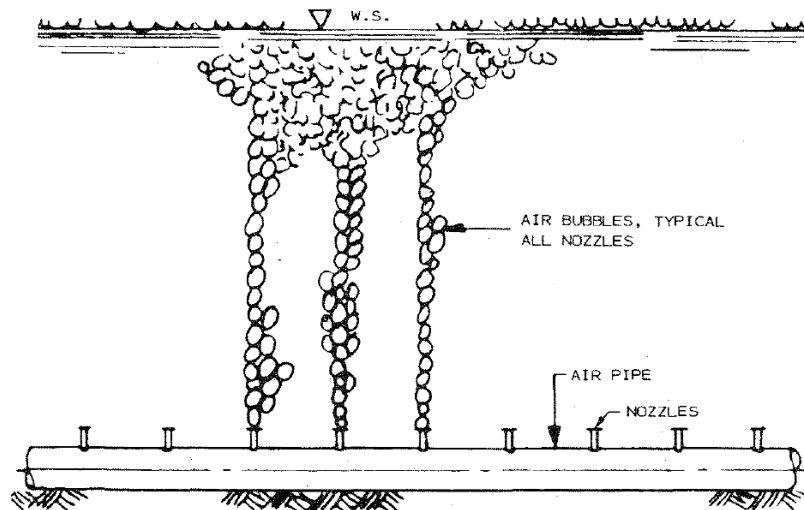

**Figure 4.20 Elevation View of Air Bubble Curtain [Ref. 6.2]**

Air bubble curtain systems were in operation for several years (late-1970’s through the mid-1980’s) at each of the Unit 1 and Unit 2 traveling water screens and one traveling water screen (TWS 36) at Unit 3, but were removed after yielding poor results [Ref. 6.15; Ref. 6.109]. The studies of the Stations’ air bubble curtain noted that the effectiveness was lower at night and during periods of high turbidity, which support the observation that fish respond to air bubbles visually and not through auditory or tactile stimuli [Ref. 6.18]. Air bubble curtain effectiveness may also be dependent on water temperature with decreased effectiveness associated with lower water temperatures [Ref. 6.108]. The air burst curtain at the Stations proved to be ineffective against white perch, striped bass, and clupeids [Ref. 6.15]. In some cases, the use of air bubble curtains increased impingement rates [Ref. 6.108].

Other field studies examining the effectiveness of air bubble curtains in reducing fish impingement at CWISs have been completed. One study on air bubble curtains was conducted in 1972 at Monroe Power Plant on Lake Erie [Ref. 6.15]. The curtains were turned on and off for seven day intervals during the study period. Results showed that the air bubble curtains were ineffective and did not reduce impingement in yellow perch, walleye, gizzard shad, drum, alewife, or smelt. Another air bubble curtain study conducted at Prairie Island Nuclear Generating Station on the Mississippi River in the 1970s showed inconsistent results [Ref. 6.15]. Small decreases in impingement of crappie and freshwater drum were observed; however, the number of impinged carp, silver chub, and white bass increased.

### Conclusions

Although dated, effectiveness studies at the Stations and elsewhere failed to establish reduced impingement in associated with air bubble curtains. Moreover, because eggs and larvae cannot respond to the stimuli created by air bubble curtains, there would be no

direct reduction in entrainment. For these reasons, air bubble curtains are not expected to provide significant biological benefits at the Stations and are not further considered as alternatives to the current CWIS technologies.

#### 4.4.3.4 Electrical Barriers

Electrical barriers deter fish by introducing electrical currents into the waterway. An electrical field is created by applying a voltage across two submerged electrodes. When fish are caught in the electrical field their behavioral response is to turn sideways to avoid the stress caused by the electrical current passing through their bodies. Orienting the electrical field parallel to the flow direction, which is generally the same as the direction fish are travelling in, results in the maximum voltage being applied to the fish (i.e., electric field lines run head-to-tail along the fish in the same direction as the flow). By turning perpendicular to the flow, fish entrained in the electrical barrier cannot continue swimming upstream and are swept away by the waterway's natural current as shown in Figure 4.21.

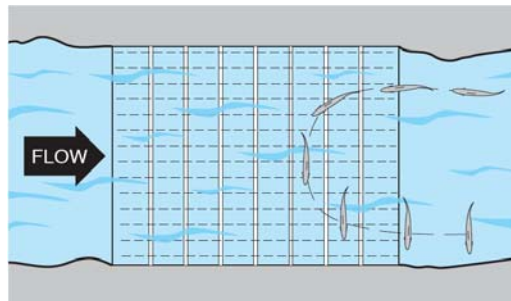

**Figure 4.21 Fish Path in a Graduated Electric Field [Ref. 6.104]**

Electrical barriers are most commonly installed to impede upstream migration of invasive fish species. However, some have been designed to deter fish from intake structures for hydropower facilities [Ref. 6.104]. There are no known permanent electrical barriers in operation at a nuclear facility's CWIS.

The electrical barriers designed by Smith-Root, Inc. for fish barrier and avoidance purposes utilize short duration direct current (DC) pulses and a graduated electrical field [Ref. 6.104]. Alternating current (AC) pulses and long, continuous pulses have proven to be more stressful to fish and are not used as a deterrent [Ref. 6.104]. The graduated electrical field consists of pulse generators providing a voltage to an electrode array on the floor of the water body as shown in Figure 4.22.

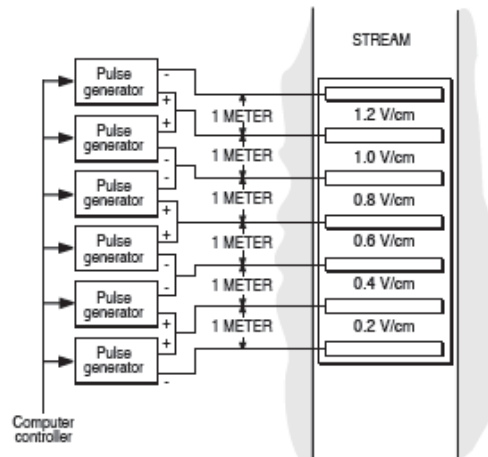

**Figure 4.22 Graduated Electrical Field Configuration [Ref. 6.119]**

The voltages of the pulse generators are set to be successively increasing, resulting in an additive effect on the electrical field's strength. Smith-Root offers output voltages of 40, 80, 120, 160, 200, and 240 V with pulse durations ranging from 0.15 milliseconds to 10 milliseconds. Voltage and pulse durations are chosen based on the specific species of fish that the barrier is aiming to exclude [Ref. 6.104].

Electrical barriers have been widely dismissed as a feasible alternative to reduce fish impingement and entrainment at CWISs due to technological reliability issues [Ref. 6.2]. Electrical field strength is highly dependent on the conductivity of the water. In estuarine applications, such as IPEC, salinity can vary greatly leading to large deviations in the conductivity of the water [Ref. 6.2]. Large variability in field strength can lead to paralysis or even mortality to the fish [Ref. 6.2]. The effectiveness of electrical barriers can also be reduced by variations in flow characteristics of the water body. If the natural flow velocity of the water body is less than the intake flow velocity, the electrical barrier can paralyze fish resulting in them being entrained in the CWIS. The Unit 2 and Unit 3 CWISs have an intake water approach velocity of approximately 1 fps at full flow and approximately 0.6 fps at reduced flow [Ref. 6.24]. Current measurement data collected offshore of IPEC during three tidal cycles showed a maximum flood velocity of 1.5 fps and maximum ebb velocity of 3.3 fps. Based on these maxima, the average flood velocity is 1.0 fps and the average ebb velocity is 2.1 fps [Ref. 6.11]. In addition, a slack tide lasts for a short period as the tide changes between flood and ebb conditions. Thus, there are periods where the average River velocity is less than the intake flow velocity at the entrance to the CWISs. Electrical barriers would likely be ineffective during these periods, and could increase impingement rates by reducing the ability of fish to travel away from the CWISs.

The sizes of the species at the Stations vary from small bay anchovy with lengths approximately 100 mm to large striped bass with lengths capable of exceeding 80 cm [Ref. 6.118]. These differences in length can greatly hinder the performance of an electrical barrier. The electrical barrier voltages are calibrated to deter a specific species type and size. A voltage suitable for deterring one species could potentially be fatal to another species due to the greater stresses caused on the species by the electrical field

[Ref. 6.2]. Conversely, a lower voltage capable of safely deterring one species could be incapable of deterring another species, allowing it to travel through the electrical barrier and possibly be entrained in the intake. In addition, the voltages introduced in the water body by electrical barriers are potential hazards for humans as well as fish [Ref. 6.104].

#### Conclusions

Design and installation of an electrical barrier at the Stations would require extensive site specific studies to determine the optimum location, size, and electrical field strength of the system. The effectiveness of electrical barrier systems is highly site-specific and dependent upon the conductivity of the water, natural flow of the waterbody, and size of the species. Based on the existing intake flow rates at the entrance to the CWISs and the average River velocities, operation of electrical barriers could increase impingement mortality. Moreover, because eggs and larvae cannot swim away from the stresses created by an electrical barrier, there would be no direct reduction in entrainment. For these reasons, electrical barriers are not expected to provide significant I&E reductions and are not further considered as alternatives to the current CWIS technologies.

#### **4.4.4 Louver System**

Louver systems are not considered as viable alternatives to the current screening systems at the Stations because they would not be expected to provide comparable reductions in I&E to the NYSDEC Proposed Project or other alternative technologies. Because eggs and larvae cannot swim away from the turbulence created by a louver system, there would be no associated reduction in entrainment. Additional site-specific biological studies would be required to produce an optimized louver system design for the Stations.

Louver systems are passive guidance barriers that typically consist of a series of evenly spaced, vertical panels aligned across the face of an intake system at an angle to the incoming flow to reduce impingement. The louver panels cause an abrupt change in the velocity and direction of the flow, creating a turbulence zone in front of the panels that fish avoid [Ref. 6.35]. Fish tend to align themselves parallel and headfirst with the incoming flow, thus coming in contact tail first with the turbulence zone. Typically, fish will move away from the turbulence zone in a direction perpendicular to the angled louvers. The net effect of this behavioral response, after repeated excursions away from the turbulence zone, is a lateral displacement of fish towards the end of the angled louvers into a bypass channel that returns fish to the source waterbody [Ref. 6.110]. A plan view of a typical louver array is shown in Figure 4.23.

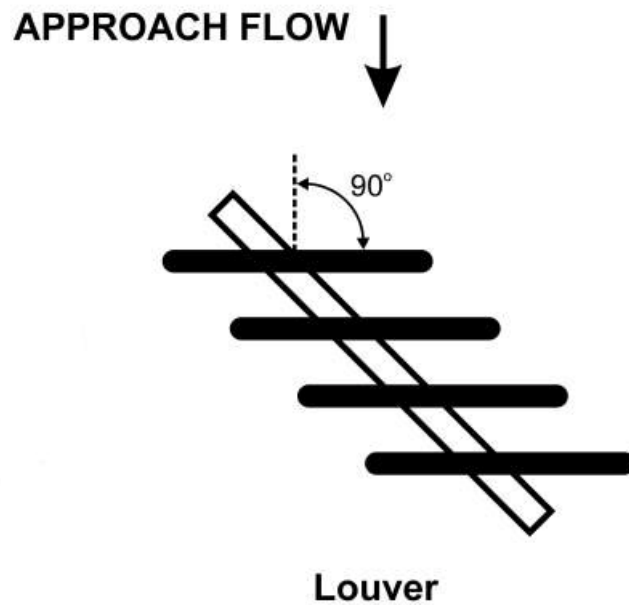

**Figure 4.23 Typical Louver Array [Ref. 6.110]**

Retrofitting louver systems upstream of the existing TWSs at the Stations would require significant civil/structural modifications. Louver arrays and a bypass channel would have to be constructed in each intake channel. The bypass channel would reduce the width of the intake channel available for flow downstream to the existing TWSs resulting in an increase in through-screen velocity and likely increase in impingement mortality.

#### I&E Discussion

Because eggs and larvae cannot swim away from the turbulence of the magnitude created by louver systems, there would be no associated reduction in entrainment [Ref. 6.107]. EPRI indicated that louver systems could provide 80-95% diversion efficiency for a wide variety of species under a range of site conditions; however, latent mortality could be a concern [Ref. 6.107]. Fish entrained in an intake channel with a louver system typically spend long periods of time swimming against the flow, just ahead of the louvers. Alden Research Laboratory (ARL) performed a series of test flume experiments where the cross-channel width of the test flume was 6 ft and the duration of the experiments ranged from 15 minutes to almost 13 hours. ARL found that the residence time of fish was often much greater than the planned duration of the experiment. In 55 of the 58 experiments conducted by ARL, fish remained swimming in the flume after the termination of the experiment. As the residence time within the intake channel increases above certain minimums, fish are more likely to suffer exhaustion and be impinged against the louver panels before reaching the bypass. The ARL study concluded that louver systems had marginal success in guiding fish into the bypass channel, as fish were more often impinged against the louvers [Ref. 6.35].

Additional studies conducted by Stone and Webster concluded that the angle of the louver system to the incoming flow ( $25^\circ$  and  $45^\circ$  in their tests) had no effect on the efficiency of the system; however, fish suffered more physical damage in tests conducted with the louvers at  $45^\circ$  than they did with the louvers at  $25^\circ$  [Ref. 6.35]. The effectiveness of

diverting fish uninjured to the bypass is more closely related to the cross-channel distance of the angled louver system than the pitch of the louvers. The cross-channel distance of a louver system is increased by 1.41 to 2.37 times the perpendicular distance in the range of 25° to 45° as shown in Figure 4.24.

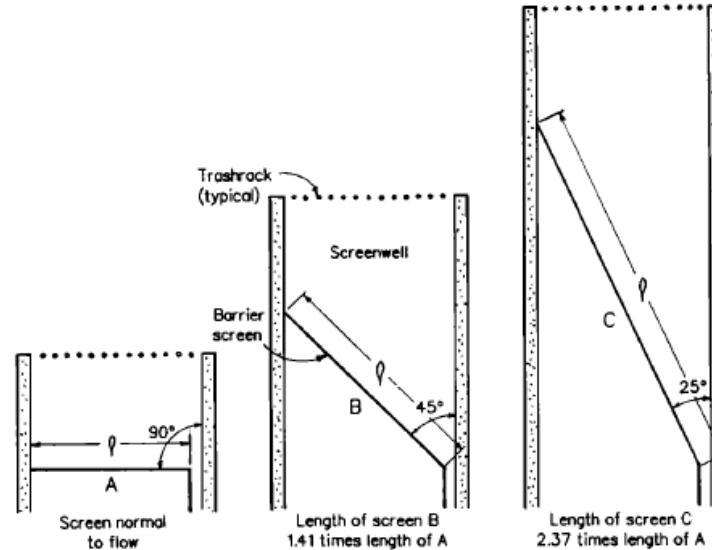

**Figure 4.24 Cross-channel Distance of Louver Systems [Ref. 6.110]**

The CW channels of Unit 2 and Unit 3 have perpendicular cross-channel distances of 13 ft 4 inches, approximately 2.2 times the distance of the ARL test flume. The approximate cross-channel distance of a louver system within a CW channel at the Stations would range between 18 ft 10 inches at 45° to 31 ft 8 in at 25°. The residence time of fish within a CW channel at IPEC equipped with a louver system is expected to be significantly greater than the residence times reported in the ARL study, thus increasing the possibility of fish impingement against the louver arrays due to exhaustion.

### Conclusions

A site-specific study would be required to produce an optimized louver system design for the Stations and determine the biological benefits of the system. However, based on the studies, louver systems would not be expected to provide any appreciable reductions in impingement at the Stations. Moreover, because eggs and larvae cannot swim away from the turbulence created by a louver system, there would be no associated reduction in entrainment. For these reasons, louver systems are not expected to provide significant reductions in I&E and are not further considered as alternatives to the current CWIS technologies.

## **4.5 Alternate Intake Location**

In order to evaluate the engineering feasibility of an offshore intake at the Stations and the potential I&E reductions associated with an offshore intake location(s), further studies of the Hudson River adjacent to each CWIS defining the density of aquatic organisms as a function of horizontal distance from the shoreline and vertical depth would be required. Despite extensive ongoing biological analysis at the Stations, no specific studies have been undertaken

to identify alternative offshore intake locations for Unit 2 or Unit 3, nor is there data suitable for that purpose. Therefore, the engineering feasibility of an offshore intake cannot be determined at this time (i.e., without first conducting a biological study establishing the optimum location of an offshore intake for Unit 2 and Unit 3).

As discussed in Section 2.4.1, the Unit 2 and Unit 3 CWISs currently draw water from the shoreline of the Hudson River through three concrete bulkheads that are subdivided into independent CW and SW intake channels. These are referred to as shoreline intake systems.

In addition to shoreline intake systems, intake systems can also be located offshore. Offshore intake systems typically draw in water through vertical inlets located offshore from the screen house and slightly above the floor of the waterbody.

Velocity caps can also be placed on top of the vertical inlets. Velocity caps are covers placed over the vertical inlets that convert vertical flow into horizontal flow. Velocity caps are sized to achieve a low intake velocity between 0.5 and 1.5 fps [Ref. 6.115]. Fish impingement is reduced through the use of velocity caps because fish tend to avoid changes in horizontal flow but are less able to detect and avoid changes in vertical flow. However, velocity caps provide no significant reduction in entrainment of larvae or eggs [Ref. 6.115]. As shown in Figure 4.25, a velocity cap reduces the approach velocities, and converts vertical flow into horizontal flow at the entrance of the intake [Ref. 6.26].

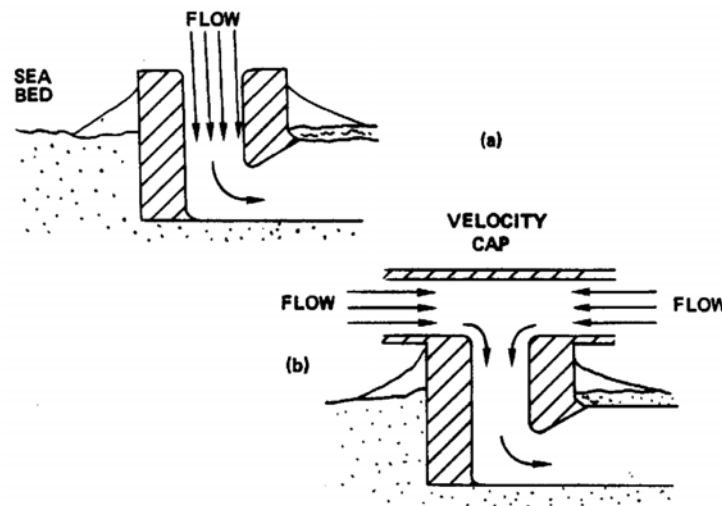

**Figure 4.25 Typical Velocity Cap Flow Direction**

Locations of offshore intakes, where feasible, are determined by various site-specific factors. Extensive studies generally are conducted to determine the optimum offshore location of the vertical inlets to minimize I&E. In estuaries, species distribution and abundance are determined by a number of physical and chemical attributes including geographic location, salinity, temperature, oxygen level, currents, and substrate. These factors, along with the degree of vertical and horizontal mixing in the estuary, dictate the spatial distribution and movement of organisms [Ref. 6.115].

An alternative offshore intake location would require significant modifications to the CWISs, including potential significant modifications to the River bed directly adjacent to the CWISs. In order to connect the velocity cap(s) to the intake channels of the existing CWISs, a large



diameter intake tunnel would need to be constructed below the floor of the Hudson River. The design, location, and depth of an offshore intake would be dependent on technological limitations and potential biological benefits.

JAF is located on the southeastern shore of Lake Ontario. The CWIS at JAF consists of an offshore submerged velocity cap that feeds an underground D-shaped tunnel running beneath the lake bed to an in-shore screenwell building that contains the majority of supporting intake equipment. Three 120,000 gpm circulating water intake pumps and three 18,000 gpm service water pumps (two are required for normal operation) draw water through the offshore intake into the in-shore screenwell building. The offshore intake is located over 900 ft from the shoreline of Lake Ontario in approximately 25 ft of water. The offshore intake has four segmented shore-facing openings that feed a D-shaped intake tunnel that runs beneath the lake bed approximately 1150 ft to the in-shore screenwell building. Attached to the velocity cap are 88 internally heated bar racks used to prevent intake clogging due to frazil ice or excessive icing [Ref. 6.68].

#### I&E Discussion

In order to determine the potential I&E reductions at IPEC an extensive site-specific study would be required to determine the optimum location. A three year biological study to assess the possible extension of the cooling water intake structure at JAF began in early 2009 and is scheduled to conclude in late 2011. In accordance with the study plan submitted to the DEC, the fish species type and density at each sampling location is determined through scheduled hydroacoustic surveys and physical sampling using trawl and gill nets [Ref. 6.93]. A similar study would be required at IPEC.

#### Conclusions

Despite extensive ongoing biological analysis, no specific studies have been undertaken to identify alternative offshore intake locations for Unit 2 or Unit 3, nor is there data suitable for that purpose. Thus, further studies of the Hudson River adjacent to each CWIS defining the density of aquatic organisms as a function of horizontal distance from the shoreline and vertical depth would be required to evaluate the potential I&E reductions associated with an offshore intake location(s). Therefore, the engineering feasibility of an offshore intake cannot be determined at this time (i.e., without first conducting a biological study establishing the optimum location of an offshore intake for Unit 2 and Unit 3).

## **4.6 Flow Reduction**

Flow reductions at the Stations could be achieved through the use of new or existing technologies (i.e., dual/variable speed pumps), operational measures (i.e., outage timing), or by replacing some or all of Hudson River water used for cooling water with an alternative source of cooling water (i.e., recycled wastewater or water from radial wells). However, additional flow reductions via new or existing technologies (i.e., dual/variable speed pumps) or operational measures (i.e., outage timing) would not be expected to provide significant biological benefits over the current flow reductions achieved by using the existing technologies and operational measures. In addition, due to insufficient amounts of recycled wastewater in the vicinity of the Stations and the limited sources of available groundwater and

land space at the Stations, the use of recycled wastewater or radial wells are not considered a technologically feasible means of significantly reducing I&E.

#### **4.6.1 Dual/Variable Speed Pumps**

Currently, the Stations reduce flow through the use of operational measures and flow reduction technologies (i.e., dual speed pumps at Unit 2 and variable speed pumps at Unit 3). The historical flow reductions (from baseline) at the Stations are described in Section 2.4.2.3. The potential for further operational flow reductions is based on equipment operational limits and operating performance impacts. Current operation is governed by limitations used to ensure adequate reliability and safety, among other factors. If it is expected that these limits may be exceeded, the Stations are required to operate atypically under various levels of restriction that decrease the net power generated.

To evaluate the potential impact of further operational flow reductions, limits on the condenser pressure and cooling water velocity were used to develop the maximum flow reductions available. A computational model of each Unit was then used to determine the operational impacts of flow reductions up to the developed limits at each Unit.

##### **4.6.1.1 Flow Reduction Parameters/Methodology**

###### **4.6.1.1.1 Main Condenser Pressure Limit**

As described in Section 2.2.2, the objective of the main condenser is to provide a heat sink for the turbine exhaust steam, turbine bypass steam, and other related flows. The main condenser is of the single pass, divided water box, de-aerating type. It consists of two shells, one for each low pressure turbine cylinder, and is a River-water-cooled unit located directly beneath the low pressure cylinders of the main turbine.

The Unit 2 condenser low vacuum alarm is set at 25 in-Hg vacuum, or approximately 5 in-Hg atmospheric [Ref. 6.65], and the Unit 3 low vacuum alarm is set at no lower than 26 in-Hg vacuum, or approximately 4 in-Hg atmospheric [Ref. 6.66].<sup>17</sup> If the condenser low vacuum alarm points are exceeded, the Unit is forced into a loss of condenser vacuum abnormal operating procedure (AOP). The loss of condenser vacuum AOP prompts actions to stabilize the condenser vacuum, determine the cause of loss of vacuum, and return the vacuum to normal. The AOP could lead to a required manual reactor shutdown if the condenser vacuum cannot be restored.

###### **4.6.1.1.2 Cooling Water Velocity Limit**

The thermal performance of the condenser is dependent on the cooling water velocity through the condenser tubes, in conjunction with the amount of fouling of the tubes. According to the Heat Exchange Institute (HEI) [Ref. 6.38], water velocities of less than 3 fps through the condenser tubes do not build up enough flow resistance within the condenser to ensure a uniform quantity of water through all of the tubes. Without

<sup>17</sup> The pressure setpoints listed in the Alarm Response Procedures [Ref. 6.65; Ref. 6.66] are 25 and 26 in-Hg absolute for Units 2 and 3, respectively. Subtracting each of these setpoints from a standard atmospheric pressure of 29.92 in-Hg results in the main condenser vacuum setpoints of 3.92 and 4.92 in-Hg for Units 2 and 3, respectively.

sufficient flow resistance in the condenser tubes, heat transfer through the tubes would not be uniform and there would be an increased potential for fouling. Condenser performance under such conditions cannot be accurately predicted, and any correlation resulting from calculations or modeling using an input velocity below 3 fps cannot be regarded as a valid analysis [Ref. 6.38]. In addition, reduced flow velocities through the condenser tubes would be expected to increase fouling in the tubes [Ref. 6.103]. Fouling increases resistance to heat transfer and could affect the performance of the condenser. Therefore, in order to maintain plant performance and safety standards, the minimum sustained condenser tube velocity considered for flow reductions at each Unit is 3 fps [Ref. 6.38].

Unit 2 and Unit 3 are designed for maximum condenser tube water velocities of 4.1 fps and 6.0 fps, respectively [Ref. 6.42]. Limiting the condenser tube water velocity to 3 fps would result in a maximum available circulating water flow reduction of 27% at Unit 2 and 50% at Unit 3. The maximum available design flow reduction (i.e., circulating water flow and service water flow; see Section 2.4.2.3) resulting from condenser tube water velocities of 3 fps would be approximately 25% at Unit 2 and 45% at Unit 3.

#### **4.6.1.1.3 Inlet Water Temperature**

Eight years (2001 through 2008) of measured daily circulating water inlet temperatures were provided by the Stations. An algorithm was run to remove erroneous values, with a resulting inlet water temperature data recovery rate of 99.8%, as shown in Attachment 3, Table 3-1.

#### **4.6.1.1.4 PEPSE Model**

The performance evaluation of power system efficiency (PEPSE) model is a state-of-the-art power plant performance modeling software used by the power industry to estimate plant operational parameters and net power generated, using system inputs such as circulating water inlet temperature. The most recent PEPSE models for each Unit<sup>18</sup> were reviewed, updated, and run to produce the results discussed herein. Diagrams of the Stations' PEPSE models have been included in Attachment 3, Figures 3-1 through 3-12.

The inlet water temperature data received from the Stations was input into the updated PEPSE models, and the circulating water flow was reduced in 5% circulating water flow increments and run over a bounding range of circulating water inlet temperatures (32°F to 84°F, in 2°F increments). By varying the circulating water flow rate, the impacts of flow reductions on the Stations operation were calculated. When required, the net thermal input was varied for each circulating water inlet temperatures in order to

---

<sup>18</sup> The Stations supplied a Unit 2 PEPSE model updated in 2006 and a Unit 3 PEPSE model updated in 2007. While finalizing the Report analysis, updated versions of the PEPSE models were developed by the Stations. The new models were reviewed and compared to the PEPSE models originally used for this Report. It was determined that using the new PEPSE models would not result in any significant differences in the analysis and any difference would result in greater power losses due to additional flow reduction at the Stations. Therefore, the PEPSE models used for this analysis produce conservative results.

achieve condenser vacuum levels above the alarm set points discussed in Section 4.6.1.1.1.

## **4.6.1.2 Flow Reduction Impacts**

### **4.6.1.2.1 Flow Reduction Analysis**

Using the daily measured cooling water intake temperatures at each percentage of flow reduction from baseline, the Stations' PEPSE models were used to determine the hourly operational power loss attributed to each defined design flow reduction. Operational power loss is defined here as a loss of generating capacity due to the thermodynamic effects of reduced cooling water flow through the condenser. In contrast, a parasitic loss is the electric power load required to operate the cycle under the changed conditions.

The annual average operational power losses at Units 2 and 3 are listed in Table 4.7 and Table 4.8, respectively. As shown, various levels of flow reduction from baseline could occur at each Unit without operational power losses in November through May. From June through October, however, even small amounts of flow reduction would result in operational power losses at both Units. The maximum operational power losses at Units 2 and 3 are provided in Attachment 3, Tables 3-2 and 3-3, respectively.

**Table 4.7 Unit 2 Average Power Loss (MWe) Attributed to Design Flow Reduction**

Month	Design Flow Reduction				
	5%	10%	15%	20%	25%
January	-0.1	-0.3	-0.5	-0.7	-0.9
February	-0.1	-0.3	-0.4	-0.7	-1.0
March	-0.1	-0.3	-0.5	-0.7	-0.9
April	-0.1	-0.1	-0.2	-0.2	-0.1
May	0.4	0.9	1.7	2.9	4.5
June	1.5	3.3	5.4	8.0	11.2
July	2.1	4.6	7.4	10.7	14.6
August	2.2	4.8	7.8	11.2	15.2
September	2.0	4.3	7.0	10.2	13.9
October	1.0	2.4	4.0	6.1	8.7
November	0.0	0.1	0.3	0.7	1.3
December	-0.1	-0.2	-0.3	-0.4	-0.4
Average Annual	0.7	1.6	2.7	4.0	5.6

Notes:

<sup>1</sup> Based on daily inlet water temperature measured from 2001 through 2008.

<sup>2</sup> Atypical inlet water temperatures less than 40°F excluded to remove effect of unstable cooling properties of water near the freezing point.

<sup>3</sup> The maximum available design flow reduction would be approximately 25% at Unit 2 based on the HEI-defined 3 fps limitation.

**Table 4.8 Unit 3 Average Power Loss (MWe) Attributed to Design Flow Reduction**

Month	Design Flow Reduction								
	5%	10%	15%	20%	25%	30%	35%	40%	45%
January	-0.2	-0.4	-0.6	-0.8	-1.3	-2.3	-3.5	-4.2	-4.4
February	-0.1	-0.3	-0.6	-0.8	-1.1	-2.0	-3.3	-4.2	-4.5
March	-0.2	-0.4	-0.6	-0.8	-1.3	-2.3	-3.5	-4.2	-4.3
April	-0.3	-0.7	-1.1	-1.6	-2.1	-2.7	-3.1	-3.2	-2.6
May	-0.2	-0.2	-0.1	0.1	0.4	1.0	2.2	4.2	7.9
June	0.6	1.3	2.4	3.8	5.7	8.3	11.9	16.8	23.4
July	1.5	3.3	5.6	8.4	11.7	15.9	21.0	27.4	36.9
August	1.7	3.8	6.4	9.4	13.0	17.4	22.8	29.5	42.3
September	1.2	2.8	4.7	7.1	10.2	14.0	18.8	24.8	32.8
October	0.2	0.6	1.2	2.0	3.2	5.0	7.6	11.4	17.0
November	-0.4	-0.8	-1.3	-1.7	-2.0	-2.1	-1.9	-1.2	0.3
December	-0.2	-0.5	-0.8	-1.3	-1.9	-2.7	-3.3	-3.6	-3.2
Average Annual	0.3	0.7	1.3	2.0	2.9	4.0	5.5	7.9	11.9

Notes:

<sup>1</sup> Based on daily inlet water temperature measured from 2001 through 2008.

<sup>2</sup> Atypical inlet water temperatures less than 40°F excluded to remove effect of unstable cooling properties of water near the freezing point.

<sup>3</sup> The maximum available design flow reduction would be approximately 45% at Unit 3 based on the HEI-defined 3 fps limitation

The negative power loss values shown in Table 4.7 and Table 4.8 correspond to potential power gains that could be achieved through flow reductions from baseline. Note that the Stations already achieve these power gains through operational flow reductions that currently occur in the winter months. These gains result from reduced subcooling of the condensate water. When subcooling occurs, the feedwater heater duty increases and turbine output is reduced. Therefore, when subcooling is reduced, turbine output and power production increase. The ability to increase power generated due to reduced subcooling is reflected in the efficient flow schedule currently in place at each Unit [Ref. 6.89].

However, the thermodynamic advantage resulting from a reduction in condensate subcooling would be somewhat counteracted by a parasitic pump load increase. As flow is reduced from 140,000 gpm to 70,000 gpm, the power load required to operate the Unit 3 variable speed pumps increases, with peak required load at approximately 95,000 gpm [Ref. 6.63]. The power load increase is due to decreasing pump efficiency and increasing total dynamic head as flow is reduced. The motor efficiency and drive efficiency would also be expected to decrease as flow is reduced [Ref. 6.102], further increasing the power load required to operate the pumps. The total power load increase is estimated to be less than 1 MWe at each Unit for the majority of operating conditions. Therefore, the parasitic power load increase has been neglected to ensure a conservative estimate (i.e., the net power loss at each Unit would actually be slightly more than predicted here).

#### 4.6.1.2.2 Power Reduction Analysis

Using the PEPSE modeling output previously described, the daily flow reduction available was calculated given an available threshold power loss. Table 4.9 and Table 4.10 provide the incremental reductions in design flow for reductions of active power in 5 MWe increments at Units 2 and 3, respectively. The tabulated values depict the average percentage of circulating water reduction available, given the HEI defined 3 fps condenser flow velocity restriction [Ref. 6.38]. Due to the condenser flow velocity limit of 3 fps, no additional reductions in flow could be achieved, and, therefore, no additional losses in active power above 20 MWe and 40 MWe for Units 2 and 3, respectively, would be warranted.

**Table 4.9 Unit 2 Average Design Flow Reduction Available at Defined Power Loss**

Month	Power Loss Threshold (MWe)				
	0	5	10	15	20
January	25.0%	25.0%	25.0%	25.0%	25.0%
February	25.0%	25.0%	25.0%	25.0%	25.0%
March	25.0%	25.0%	25.0%	25.0%	25.0%
April	18.4%	25.0%	25.0%	25.0%	25.0%
May	1.3%	23.5%	25.0%	25.0%	25.0%
June	0.0%	14.5%	22.5%	25.0%	25.0%
July	0.0%	10.7%	18.9%	24.9%	25.0%
August	0.0%	10.3%	18.3%	24.6%	25.0%
September	0.0%	11.3%	19.7%	24.9%	25.0%
October	0.3%	17.9%	24.0%	25.0%	25.0%
November	10.1%	24.9%	25.0%	25.0%	25.0%
December	22.8%	25.0%	25.0%	25.0%	25.0%
Average Annual	10.6%	19.8%	23.2%	24.9%	25.0%

Notes:

<sup>1</sup> Based on daily inlet water temperature measured from 2001 through 2008.

<sup>2</sup> Atypical inlet water temperatures less than 40°F excluded to remove effect of unstable cooling properties of water near the freezing point

<sup>3</sup> Values highlighted yellow represent those months restricted solely by the HEI-defined 3 fps limitation.

**Table 4.10 Unit 3 Average Design Flow Reduction Available at Defined Power Loss**

Month	Power Loss Threshold (MWe)								
	0	5	10	15	20	25	30	35	40
January	45.0%	45.0%	45.0%	45.0%	45.0%	45.0%	45.0%	45.0%	45.0%
February	45.0%	45.0%	45.0%	45.0%	45.0%	45.0%	45.0%	45.0%	45.0%
March	45.0%	45.0%	45.0%	45.0%	45.0%	45.0%	45.0%	45.0%	45.0%
April	44.9%	45.0%	45.0%	45.0%	45.0%	45.0%	45.0%	45.0%	45.0%
May	16.9%	41.9%	44.4%	44.9%	45.0%	45.0%	45.0%	45.0%	45.0%
June	0.2%	24.5%	33.3%	38.6%	42.2%	44.7%	45.0%	45.0%	45.0%
July	0.0%	13.9%	22.6%	29.0%	34.1%	38.9%	44.2%	45.0% <sup>4</sup>	45.0%
August	0.0%	12.4%	20.9%	27.3%	32.5%	36.7%	42.5%	45.0% <sup>4</sup>	45.0%
September	0.0%	15.9%	24.9%	31.1%	36.4%	41.8%	44.5%	45.0%	45.0%
October	4.5%	31.7%	38.6%	42.5%	44.1%	45.0%	45.0%	45.0%	45.0%
November	40.0%	44.8%	45.0%	45.0%	45.0%	45.0%	45.0%	45.0%	45.0%
December	44.9%	45.0%	45.0%	45.0%	45.0%	45.0%	45.0%	45.0%	45.0%
Average Annual	23.7%	34.1%	37.8%	40.2%	42.0%	43.5%	44.7%	45.0%	45.0%

Notes:

<sup>1</sup> Based on daily inlet water temperature measured from 2001 through 2008.

<sup>2</sup> Atypical inlet water temperatures less than 40°F excluded to remove effect of unstable cooling properties of water near the freezing point

<sup>3</sup> Values highlighted yellow represent those months restricted solely by the HEI-defined 3 fps limitation.

<sup>4</sup> Values round-up to 45.0%, but include days which were not limited by the HEI-defined 3 fps limitation.

#### 4.6.1.3 Effects of Further Operational Flow Reductions

As described in Section 2.4.2.1, Unit 2 is currently equipped with dual speed CW pumps, and Unit 3 is equipped with variable speed CW pumps. The Stations utilize both the dual speed (Unit 2) and variable speed (Unit 3) CW pumps to provide significant reductions in CW flow rates.

##### I&E Discussions

Attachment 6 (Tables 17 and 23 of Appendix A) provide the estimated reductions from the regulatory baseline in EA1 losses that could be achieved using the flow reductions associated with the defined power losses presented in Table 4.9 and Table 4.10. These reductions also account for the Stations' survival rates (Attachment 6) and average historic flow reductions (Section 2.4.2.3.2). From Attachment 6 (Tables 17 and 23 of Appendix A), Table 4.11 presents the potential reductions in EA1 I&E corresponding to various active power reductions. As discussed in Section 4.6.1.1.2, the available design flow reduction would be limited to approximately 25% at Unit 2 and 45% at Unit 3, due to the HEI-defined 3 fps limitation. Because no additional reductions in flow could be achieved, no additional losses in active power above 20 MWe and 40 MWe for Units 2 and 3, respectively, would be warranted.



**Table 4.11 Potential Percent Reduction of Annual EA1 I&E Losses at Defined Power Losses in Each Month**

Month	Power Loss Threshold ( <i>Unit 2 / Unit 3</i> )					
	<i>0 / 0 MWe</i>		<i>20 / 20 MWe</i>		<i>20 / 40 MWe</i>	
	EA1 Entrainment	EA1 Impingement	EA1 Entrainment	EA1 Impingement	EA1 Entrainment	EA1 Impingement
January	0.0%	8.8%	0.0%	8.8%	0.0%	8.8%
February	0.0%	9.6%	0.0%	9.6%	0.0%	9.6%
March	0.0%	12.0%	0.0%	12.0%	0.0%	12.0%
April	0.4%	6.7%	0.4%	6.7%	0.4%	6.7%
May	6.3%	7.4%	6.5%	7.9%	6.5%	7.9%
June	14.9%	8.5%	17.2%	9.9%	17.2%	10.0%
July	7.3%	4.0%	11.8%	4.4%	13.0%	4.5%
August	4.2%	4.2%	7.0%	4.5%	7.6%	4.7%
September	1.4%	4.4%	2.7%	4.8%	2.9%	4.9%
October	1.2%	3.9%	2.2%	4.4%	2.2%	4.4%
November	0.0%	4.7%	0.0%	5.0%	0.0%	5.0%
December	0.0%	6.5%	0.0%	6.5%	0.0%	6.5%
Annual	35.7%	80.7%	47.8%	84.7%	49.9%	85.0%

The maximum possible entrainment reduction shown in Table 4.11 (49.9%) is only 16.1% more than the current entrainment reductions based on the historic flow reductions discussed in Section 3.2 and would require substantial continuous losses in generation. In addition, the EA1 I&E reductions presented in Table 4.11 remain well below the potential percent reduction that could be achieved through conversion of IPEC to closed-loop cooling.

#### Conclusions

The maximum available reductions from baseline in EA1 I&E associated with reductions in the design flow rates would be approximately 85.0% and 49.9%, respectively. In addition, these reductions would correspond to continuous active power reductions of up to 20 MWe at Unit 2 and 40 MWe at Unit 3. As discussed in Section 4.6.1.2.2, additional losses in active power would not produce additional reductions in the design flow rates. These reductions would not be comparable to those potentially achievable by the NYSDEC Proposed Project, and a significant cost would be associated with the active power reductions resulting from the flow reductions.

#### **4.6.1.4 Conversion of Unit 2 to Variable Speed Pumps**

Both dual speed pumps and variable speed pumps allow reduced intake flow rates when ambient River temperatures are low, although variable speed pumps would provide significantly greater flow control, as the flow can be varied continuously between the maximum and minimum flow rates. The Unit 2 dual speed pumps operate at 140,000 gpm or 84,000 gpm [Ref. 6.60]. Therefore, each dual speed pump allows for reductions in flow of 0% (full flow), 40% (reduced flow), and 100% (pump offline). Reducing the

flow rate of individual dual speed pumps allows incremental flow reductions from baseline flow (i.e., maximum design flow for the Unit 1 RW and Unit 2 SW and CW pumps) of 6%, 13%, 19%, 25%, 32%, and 38% per Unit. Although the dual speed pumps have the capabilities of significantly reducing the intake flow rates at Unit 2, flow reductions of more than 25% would violate the condenser tube water velocity limit discussed in Section 4.6.1.1.2.

#### Conclusions

Although the use of variable speed pumps at Unit 2 would provide significantly greater flow control and smoother transitions between flow rates, the existing dual speed pumps provide sufficient flow reduction increments up to, and including, the maximum flow reduction of 25% allowable at Unit 2. Therefore, conversion of the Unit 2 dual speed pumps to variable speed pumps is not likely to provide any appreciable biological benefit.

### **4.6.2 Use of Recycled Wastewater as Cooling Water**

Reductions in the amount of Hudson River water used for cooling at the Stations, constituting a reduction in flow, could be achieved through the replacement of some or all of Hudson River water with an alternative source (i.e., recycled wastewater or water from radial wells). However, the use of recycled wastewater from waste treatment facilities, frequently referred to as grey water, as an alternative to using River water for thermal rejection from the each Unit's condensers is not considered as a viable method of flow reduction due to the lack of available sources in the vicinity of IPEC. To fulfill the Stations' heat transfer requirements using recycled wastewater as an alternative to Hudson River water, the approximate volume and flow required would have to be the same or greater than the volume and flow needed when using Hudson River water as the CW source.

In order to determine the availability of recycled wastewater in the vicinity of IPEC, the permitted discharge flow rates were determined for the SPDES-permitted Westchester County wastewater treatment facilities (with their distance from IPEC established). The discharge flows listed in the SPDES Permits for all wastewater treatment facilities in Westchester County are included in Table 4.12 (see Attachment 7).

**Table 4.12 SPDES Water Discharge Permit Flows**

Facility (SPDES Permit)	Flow	% Req'd CW Flow	Driving Distance to IPEC (approx.)	Direct Distance (approx.)
Buchanan WWTP (NY0029971)	0.5 MGD (347.2 gpm)	0.02%	<1 mi.	<1 mi.
Peekskill WWTP (NY100803)	10 MGD (6,944.4 gpm)	0.41%	4 mi.	3 mi.
Ossining WWTP (NY108324)	7 MGD (4,861.1 gpm)	0.29%	10 mi.	9 mi.
Yorktown Heights WWTP (NY0026743)	1.5 MGD (1,041.7 gpm)	0.06%	13 mi.	9 mi.
North Castle WWTP (NY109584)	0.38 MGD (263.9 gpm)	0.02%	25 mi.	16 mi.
Wild Oaks WWTP (NY0065706)	0.06 MGD (41.7 gpm)	0.0025%	29 mi.	16 mi.
Port Chester WWTP (NY0026786)	6 MGD (4,166.7 gpm)	0.25%	30 mi.	25 mi.
Oakridge WPCF (NY0030767)	0.08 MGD (55.6 gpm)	0.0033%	31 mi.	23 mi.
Yonkers Joint WWTP (NY0026689)	92 MGD (63,888.9 gpm)	3.8%	31 mi.	25 mi.
Blind Brook WWTP (NY0026719)	5 MGD (3,472.2 gpm)	0.21%	32 mi.	26 mi.
Mamaroneck WWTP (NY0026701)	18 MGD (12,500.0 gpm)	0.74%	34 mi.	26 mi.
New Rochelle WWTP (NY0026697)	13.6 MGD (9,444.4 gpm)	0.56%	38 mi.	27 mi.
<b>Total</b>	<b>154.12 MGD (107,027.8 gpm)</b>	<b>6.37%</b>	<b>278 mi.</b>	<b>206 mi.</b>

The closest wastewater treatment facility, Buchanan Wastewater Treatment Plant, is located less than 1 mile away from IPEC and discharges on average only 347.2 gpm. Yonkers Joint Wastewater Treatment Plant discharges 63,888.9 gpm, far more than any plant in Westchester County; however, it is located approximately 25 miles away and discharges only 3.8% of the 1,680,000 gpm required for normal CW flow. Furthermore, if the discharge from every wastewater treatment facility in Westchester County were combined, the amount of River water needed as a circulating fluid would be reduced by only 6.37% for both Units, or 12.74% for one Unit only, and would require between 205 and 277 miles of pipeline.

### Conclusions

Due to the limited sources of recycled wastewater in the vicinity of IPEC, recycled wastewater is not considered a technologically feasible means of significantly reducing I&E.

#### **4.6.3 Outage Timing**

The strategic timing of maintenance outages would not be able to significantly reduce EA1 I&E over the Stations' existing technologies and operational measures. As discussed in Section 2.4.2.3, maintenance outages at the Stations have the potential to significantly reduce the flow entering a CWIS during the outage periods. When a Unit is offline, a minimal amount of flow enters the CWIS as some CW would still be required after shutdown and prior to restart. Adequate SW flow must also be provided when the Unit is offline in order to maintain essential cooling of nuclear safety-related systems.

Currently, scheduled maintenance outages at each Unit occur every 24 months and are anticipated to approximately 25 days. The outages are staggered so that the Units are not offline at the same time. The current outage schedule for Unit 2 and Unit 3 calls for spring outages for each Unit. A three year schedule of requested outage dates is filed annually with New York Independent System Operator (NYISO), which reviews the requested schedule and approves or disapproves the outage dates [Ref. 6.85]. Maintenance outages are typically scheduled between seasons of peak electrical demand, between the high use winter months (December, January, and February) and the high use summer months (June, July, and August). As discussed in Section 3.2, the Stations' existing technology is considered state-of-the-art for impingement; therefore, and outage timing considerations focus on minimizing entrainment.

Attachment 6 (Tables 17 and 23 of Appendix A) provide the potential reductions in each month due to a one Unit outage at IPEC. Table 4.11 provides the potential incremental reductions a one Unit outage would have to reduce EA1 I&E when compared to the Stations' existing reductions. These reductions would be similar for an outage at either Unit 2 or Unit 3.

**Table 4.13 Potential Incremental Reductions in EA1 I&E Losses Due to Outage Timing at One Unit From the Existing Technologies and Operational Measures**

Month	EA1 Entrainment	EA1 Impingement
January	0.0%	0.3%
February	0.0%	0.2%
March	0.0%	0.3%
April	0.1%	1.0%
May	2.1%	1.5%
June	9.7%	2.9%
July	10.7%	1.2%
August	5.3%	0.9%
September	2.6%	1.2%
October	1.8%	0.6%
November	0.0%	0.5%
December	0.0%	0.3%

As shown in Table 4.11, outages taken in the months of June, July, or August would have the highest potential to provide incremental EA1 entrainment reductions. However, while scheduling each Unit's outages for the months of June, July, or August would coincide with the optimum period for EA1 entrainment reduction, this period also reflects peak summer demand. NYISO historically has underscored the importance of the Stations' generation during this period. As such, I&E reductions associated with scheduled outage shifting to June, July, or August are not further considered. The only remaining months that would have the potential to reduce EA1 entrainment are May, September, and October where the highest incremental reduction in EA1 entrainment and impingement over the Stations' current technologies and operational measures would be 2.6% and 1.2%, respectively, in the month of September.

#### Conclusions

Assuming approval from NYISO, each Unit having bi-annual outages in September would result in potential incremental EA1 entrainment and EA1 impingement reductions of up to approximately 2.6% and 1.2%, respectively, and would not provide comparable reductions to closed-loop cooling or other alternative technologies. As such, a change in the current schedule outage timing is not further considered as an alternative to the current technologies and operational measures utilized at the Stations.

#### **4.6.4 Radial Wells**

Radial wells are not considered as a viable method of flow reduction due to the limited sources of available groundwater and land space at IPEC.

Radial wells are underground horizontal wells that draw water from the surrounding aquifer. Typical radial well systems consist of a concrete pump-well caisson installed in

the ground with several perforated collector screen pipes (laterals) protruding through wall ports into the surrounding aquifer. Radial wells draw water at low velocities through many feet of porous material, reducing the flow through the CWISs and, therefore, I&E. A typical plan and section view of a radial well system is shown in Figure 4.26.

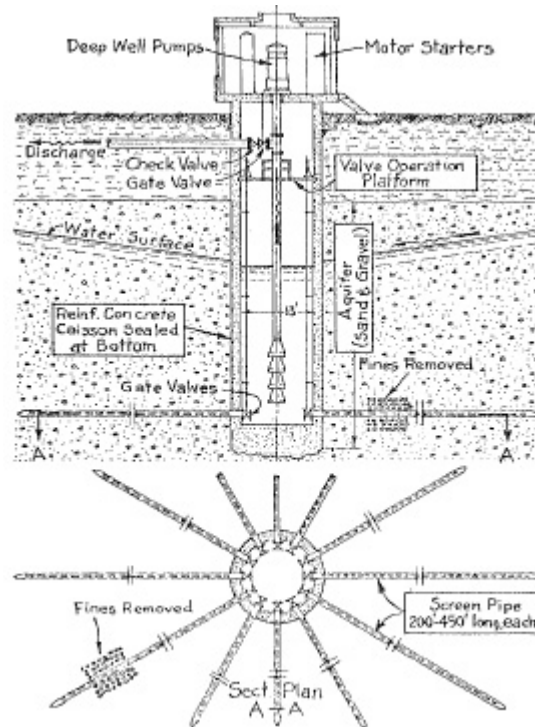

**Figure 4.26 Radial Well – Section and Plan Views [Ref. 6.2]**

Radial wells have been installed successfully at utility and municipal facilities, producing water flow rates of up to 50 MGD [Ref. 6.100]. The success of radial well technology is highly site specific and limited by the following:

- Radial wells are only suitable where there is a porous aquifer with the capacity to provide the quantity of water required. Test wells must be drilled and pump-tested to determine the exact characteristics of the aquifer and size of the required radial well system. Installation and testing of wells would take at least two to four months.
- The yield capacity of the individual caisson units is limited to approximately 25,000 gpm. However, the yield capacity is likely much less for most aquifers as the usual capacity of an individual caisson unit is 1000 to 10,000 gpm. For larger flow requirements, multiple caisson units are required and must connect to a common transmission pipe to the plant.

IPEC is situated on a complex of Cambro-Ordovician rocks represented by the Manhattan Formation and Inwood Marble Formation [Ref. 6.37]. The site lies predominantly upon the Inwood Marble Formation which consists of relatively pure carbonate rock of dolomitic and/or calcic mineralogy with silica rich zones. In the bedrock present at the

site, groundwater occurs and migrates in open fractures or voids. These void spaces are termed secondary porosity with the primary porosity being the void spaces within the bedrock itself. Inwood Marble has a very low primary porosity, and therefore does not contribute to the flow or storage of significant volumes of water [Ref. 6.37].

IPEC is located in a crystalline rock aquifer (i.e., there is limited porosity and the majority of the groundwater is in the fractures). Wells installed in a crystalline rock aquifer are typically drilled to depths ranging between 20 ft to 600 ft, yielding between 1 and 120 gpm; however, the well depths occasionally exceed 1000 ft and may yield more than 500 gpm [Ref. 6.117]. Although it is possible that higher groundwater yields could be obtained from collector screens below and near the Riverbed, site-specific pump testing would be required to determine this.

Groundwater is encountered at the site primarily in bedrock fractures and along the jointing or bedding planes of the various rock strata. Thus, groundwater may be encountered at different elevations on the site depending on the location, ground surface elevation, and if water-bearing fractures, joints, and bedding planes are encountered. Investigation performed in 2005 and 2006 indicated groundwater may be encountered in monitoring wells at the site between 3 feet to more than 80 ft above MSL and is generally encountered from 10 ft to more than 50 ft beneath the surface [Ref. 6.24].

Within a one mile radius of the site, there are seven United States Geological Survey (USGS) registered wells. As shown in Table 4.14, each well ranges in depth from 30 ft to 500 ft below the surface and, based on available information, produces between 4 gpm to 30 gpm [Ref. 6.117]. It should be noted that two of the registered wells are on the IPEC site.

**Table 4.14 Registered USGS Wells within One Mile of IPEC [Ref. 6.24]**

USGS Registered Well ID	County	Well Depth (below surface)	Approximate Distance to IPEC	Status	Capacity (gpm)	Primary Use
WE 245	Westchester	100 ft.	Onsite	Unused	4	Domestic
WE 246	Westchester	193 ft.	Onsite	Unused	N/A	N/A
WE 244	Westchester	60 ft.	3950 ft ESE	N/A	30	Unused
WE 261	Westchester	500 ft.	500 ft. ENE	N/A	25	Unused
RO 307	Rockland	192 ft.	5280 ft E	N/A	N/A	Domestic
RO 313	Rockland	30 ft.	4500 ft. NW	N/A	N/A	Domestic
RO 314	Rockland	110 ft.	5280 ft. ENE	N/A	N/A	Commercial

N/A: Information not available

As provided by Design of Water Intake Structures for Fish Protection [Ref. 6.2], the following guidelines should be considered for the conceptual design of radial well systems:

- Caisson unit spacing is typically 1500 ft; however, spacing may be closer in productive aquifers. For example, the caisson units at the Grand Gulf Nuclear Station (near Vicksburg, Mississippi) have a minimum spacing of approximately 950 feet. Pump tests conducted in the well fields determined a minimum yield of 5600 gpm.
- The diameter of the caisson depends on the space requirements for the pumps and on the clearance needed for the lateral screens. A 16 ft inner diameter is typical.

- Caissons depths of up to 200 feet are considered feasible; however, caisson depth is typically determined by the radial well vendor and is dependent on aquifer characteristics.
- The diameter of the lateral screens is typically 8 to 16 inches but sizes up to 48 inches could be considered for a very high yield aquifer.
- The maximum length of a lateral screen is approximately 450 feet for any diameter. The usual length is between 150 ft and 300 ft. The number of lateral screens and their lengths are typically determined by the vendor.
- Inflow velocity through the screens typically ranges from 1 to 2 fpm and net open area for the lateral screens typically ranges from 18 to 22 percent.
- The total length of the collector screens can be determined by the following formula:

$$\text{Length (ft)} = 2.837 * \text{Flow Rate (gpm)} / \text{Diameter (in)}$$

Based on the above design criteria, the IPEC site could conceivably support at most six radial well systems. Four radial wells could potentially be located north of the Unit 2 containment building, and two radial wells could potentially be located south of the Unit 3 containment building as shown in Attachment 2, Figure 2-19. If twelve lateral screens were installed in each caisson and each lateral screen was considered an individual well capable of producing 120 gpm, then each caisson would be capable of producing 1440 gpm. Each lateral would be approximately 22 ft long assuming a screen diameter of 16 inches, an inflow velocity of 1 fpm, and a percent open area of 18. Four radial wells servicing Unit 2 could provide up to 5760 gpm or 0.69 percent of the CW maximum design flow rate. Two radial wells servicing Unit 3 could provide up to 2880 gpm or 0.34 percent of the CW maximum design flow rate required.

#### Conclusions

Due to the limited sources of available groundwater and land space at IPEC, radial wells are not considered a technologically feasible means of significantly reducing I&E.

## **4.7 Alternative Heat Rejection and Recirculation**

No method of alternative heat rejection and recirculation – including evaporative ponds, spray ponds, cooling canals and in-river heat exchangers – is considered as a viable alternative to the current screening systems at the Stations. Due to the limited sources of land area available at IPEC, evaporative ponds, spray ponds, and cooling canals are not considered a technologically feasible means of significantly reducing I&E. In-river heat exchangers would require a large amount of surface area to dissipate the required heat load, and would create a large point source heat load in the Hudson River that would have no thermal dilution. The in-river heat exchanger temperature would exceed the maximum SPDES plant discharge temperature permit limits, particularly during periods of slack tide.

### **4.7.1 Evaporative Ponds**

Evaporative ponds, also known as cooling ponds, are not considered as viable alternatives to the current screening systems at the Stations, because the land area required for an



evaporative pond to reject the heat load of one or both Units would be much greater than the land area available at IPEC.

Evaporative ponds are bodies of water that primarily use surface evaporation to reject heat to the atmosphere. The term ‘pond’ is relative and can be applied to small or large bodies of water. In areas with low land costs, artificial cooling ponds can be relatively inexpensive to construct and operate with small makeup water requirements. Most artificial cooling ponds are relatively shallow where a minimum depth of about 3.3 feet is normal. The warm discharge water entering the cooling pond will lose and gain heat as it passes through the pond by the combined mechanisms of conduction, convection, radiation, and evaporation. However, evaporation is the main mode of heat transfer and the heat loss from the cooling pond is governed by the temperature differential between the pond surface and the atmosphere. The main disadvantage of cooling ponds is the low heat transfer rate to the air requiring large evaporative surface areas for cooling large volumes of water [Ref. 6.70]. Cooling pond areas for power generation facilities typically range between 1.24 to 2.47 acres per megawatt; however, these land area requirements are not specific to nuclear generating facilities [Ref. 6.97]. Using this rule-of-thumb approximation, the Stations would require a cooling pond area of approximately 2700 to 5300 acres to reject an appropriate amount heat from the condensers for a closed recirculating system.

The South Texas Project (STP) nuclear power plant in Bay City, Texas utilizes a 46 acre essential cooling pond as the ultimate heat sink and a 7000 acre main cooling pond for circulating water purposes. STP currently operates two 1251 MWe units (Units 1 and 2). The essential and main cooling ponds were designed to support two additional 1300 MWe reactors (Units 3 and 4). Assuming that Units 3 and 4 are constructed as specified, the land area at STP used for cooling ponds will be 1.35 acres per megawatt [Ref. 6.105]. If the Stations could obtain the same cooling pond performance as STP, approximately 2913 acres of evaporative surface area would be required to reject the heat loads from the condensers.

Sizing of a conceptual cooling pond for the Stations was conducted using the methodology specified in the Advanced Air and Noise Pollution Control (AANPC) Handbook [Ref. 6.121]. A wet bulb temperature of 33.8°F and wind speed of 4.7 mph, respectively, were selected by averaging meteorological data gathered from IPEC’s weather station between 1999 through 2008. The highest wet bulb temperature reported during this time period was 79.3°F. A design heat rejection rate of  $4.65 \times 10^9$  BTU/hr is specified by the condenser data sheets. A design surface water temperature of 93.2°F was assumed based on the maximum permitted average discharge water temperature allowed by the SPDES permit [Ref. 6.86]. The choice of a high surface water temperature is a conservative assumption because an increased temperature differential between the surface water temperature and average wet bulb temperature provides greater heat transfer resulting in a smaller cooling pond surface area. The mean solar radiation coefficient was also conservatively estimated at 3795 kilocalorie per day per square meter (kcal/d-m<sup>2</sup>), which is an average of the lower range of the short-wave and long-wave solar radiation coefficients provided in the AANPC Handbook [Ref. 6.121]. Using these inputs, a cooling pond surface area of approximately 320 acres would be required to reject the heat load from Unit 2 or Unit 3 and a cooling pond surface area of 650 acres would be required to reject the combined heat loads

generated by Units 2 and 3. These estimated areas are conservative because the surface area of actual cooling ponds would be sized to reject the required heat loads at the highest wet bulb temperature. At a wet bulb temperature of 79.3°F, approximately 6000 acres of cooling pond surface area would be required to reject the heat load from either Unit 2 or Unit 3, and approximately 12,100 acres of cooling pond surface area would be required to reject the combined heat load generated by Units 2 and 3.

### Conclusions

Although the total land area of IPEC is approximately 239 acres, only 115 acres are currently available for use because most of the site is already occupied [Ref 6.24]. As such, the land area required for a cooling pond to reject the heat load of one or both Units would be much greater than the land area available at IPEC, based on rule-of-thumb approximations, comparison to existing cooling pond systems, and theoretical design methods. Therefore, the use of a closed re-circulating cooling pond at IPEC is not further considered.

### **4.7.2 Spray Ponds**

Spray ponds are not considered as viable alternatives to the current screening systems at the Stations, because the land area required for a spray pond to reject the heat load of one or both Units would be greater than the available open area at IPEC.

Spray ponds are modified cooling ponds with spray nozzles floating on or located just above the pond surface. Water pumped through the spray nozzles is diffused into droplets increasing the surface area in contact with the ambient air, thus enhancing the rate of evaporative heat loss. Spray ponds also transfer heat to the atmosphere through evaporation from the surface of the pond similar to conventional cooling ponds. The required surface area of a spray pond can be 20 times less than the surface area required by a conventional cooling pond for an identical heat load [Ref. 6.70]. Makeup water requirements for a spray pond are larger than a conventional cooling pond due to the increased evaporation and drift, ranging from 2 to 5 percent of the water volume sprayed. Normally, spray pond nozzles are operated at a pressure of 7 psi with flow rates up to 50 gpm per nozzle. For highest efficiency, spray ponds should have a rectangular shape with the long side oriented perpendicular to the prevailing summer wind direction [Ref. 6.106].

Sizing of a conceptual spray pond system for the Stations was conducted using the methodology specified by Spraying Systems Company [Ref. 6.106]. A design wet bulb temperature of 68.5°F was selected by analysis of meteorological data gathered from IPEC's weather station between 1999 through 2008. Per the Spraying Systems Company methodology, the design wet bulb temperature is defined as the maximum wet bulb temperature which is exceeded in less than 5% of the summer time [Ref. 6.106]. The highest wet bulb temperature reported during this time period was 79.3°F. A desired spray pond outlet temperature of 75°F was selected and corresponds to the Unit 3 condenser design inlet water temperature [Ref. 6.42]. A spray pond inlet temperature of 93.2°F was assumed, corresponding to the maximum permitted discharge water temperature allowed by the SPDES permit, and a design flow rate of 1,680,000 gpm was used, corresponding to the maximum circulating water intake flow. Based on these inputs and the 50% evaporative heat transfer efficiency recommended by Spraying Systems Company [Ref.

6.106], the outlet temperature of water sprayed once through a spray pond would cool to a temperature of approximately 81°F, exceeding the desired outlet temperature of 75°F. In order to cool to the desired outlet temperature, the water would have to be re-sprayed through a second in-line spray pond. The recommended nozzle and spacing requirements [Ref. 6.106] determined that each of the spray ponds would need a surface area of approximately 60.4 acres (120.8 total acres) to reject the heat loads generated by Units 2 and 3. Each conceptual pond would require a width of 800 ft and a length of 3290 ft, and would need to be oriented lengthwise from east to west due to the prevailing north-south summer wind direction. However, this estimated area is conservative because the surface area of an actual spray pond system would be sized to reject the required heat loads during the summer months corresponding to the highest wet bulb temperature of 79.3°F.

Based on the methodology specified by Spraying Systems Company, the outlet temperature of a spray pond system cannot be less than the design wet bulb temperature. Thus, a spray pond system designed to the highest web bulb temperature (79.3°F) could not reject the heat required to provide condenser inlet water at a temperature of 75°F. Inlet water at a temperature of 93.2°F and flow rate of 1,680,000 gpm would need to be circulated through nine spray ponds to be cooled to a temperature of 79.3°F, requiring a spray pond surface area of approximately 544 acres.

### Conclusions

As discussed in Section 4.7.1, only 115 acres are currently available for use at IPEC because most of the site is already occupied. As such, the required surface area of a spray pond system would be greater than the available open area at IPEC. Therefore, the use of closed, re-circulating spray ponds at IPEC is not further considered.

### **4.7.3 Cooling Canals**

Cooling canals are not considered as viable alternatives to the current screening systems at the Stations, because the land area required for a cooling canal to reject the heat load of one or both Units would be much greater than the land area available at IPEC.

Cooling canals are long, narrow artificial bodies of water that primarily use surface evaporation to reject heat to the atmosphere. Open cooling canal systems function as thermal buffers by reducing the temperature of heated effluent prior to discharging into an ocean, River, or estuary. Re-circulating cooling canal systems operate like radiators: heated water is discharged into one end of the system, the heat is released to the environment as the water travels through the canals, and cooled water is withdrawn from the opposite end of the system. Most cooling canals are relatively shallow with depths typically ranging from 1 ft to 3 ft. Similar to evaporative cooling ponds, the main disadvantages of cooling canals are the low heat transfer rate to the air and the large surface areas required for cooling large volumes of water [Ref. 6.70].

Turkey Point Nuclear Plant (Turkey Point) in Miami-Dade County, Florida utilizes a 6700-acre re-circulating cooling canal system for cooling of its two 693 MWe nuclear reactor units (Units 3 and 4) and two 400 MWe fossil units (Units 1 and 2). As shown in Figure 4.27, the cooling canal system consists of 32 parallel canals that carry warm water from the condenser and eight parallel canals that return cooled water to the condenser inlets.

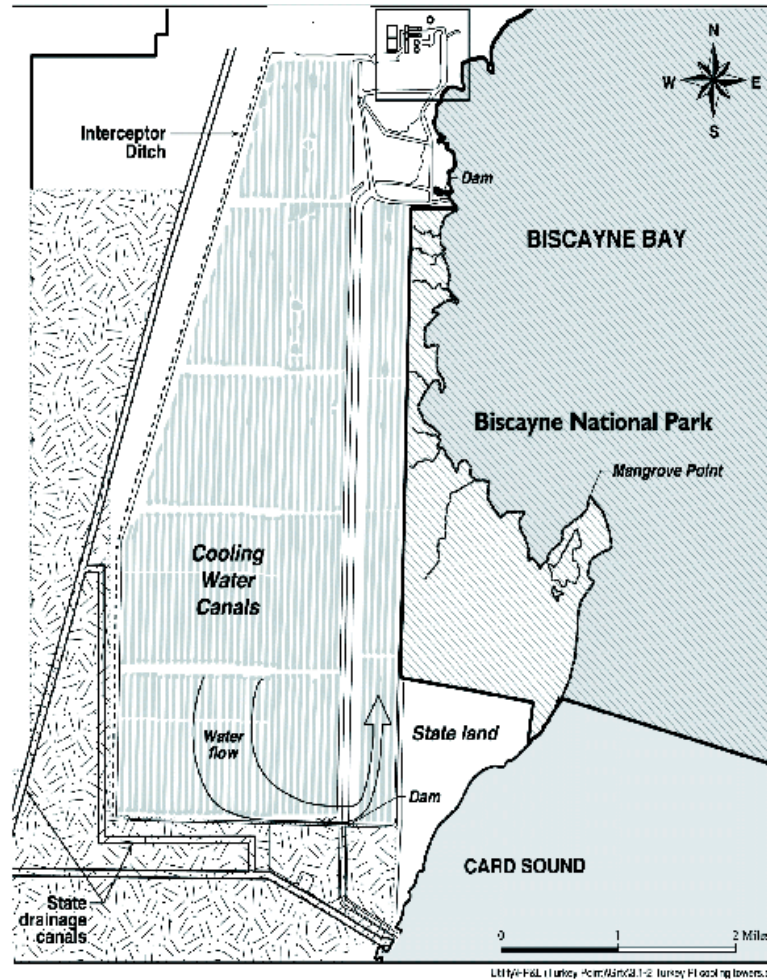

**Figure 4.27 Cooling Canal System at Turkey Point [Ref. 6.36]**

The cooling canals at Turkey Point are approximately 200 ft wide and are separated by 90 ft wide berms. The cumulative length of the canals is about 168 miles with an effective surface area of 3860 acres. Flow to the canals from Units 3 and 4 is approximately 1,300,000 gpm [Ref. 6.36]. The residence time in the canals is about 40 hours, during which time the water temperature drops to within 3 to 4°F of the adjoining Biscayne Bay's ambient temperature [Ref. 6.75]. A cooling canal system at IPEC would require less surface area than the cooling canal system at Turkey Point due to the significant difference in ambient conditions at the two sites.

The heat removal performance of a cooling canal system at IPEC is expected to be similar to a cooling pond system because each system utilizes surface evaporation as the primary mode of heat removal. Based on the heat removal performance of cooling pond systems as described in Section 4.7.1, a minimum of 320 acres of evaporative surface area would be required for the heat rejection loads of a single Unit and approximately 650 acres would be required for the heat rejection loads of Units 2 and 3 combined. The total land area necessary for a cooling canal system would likely be larger than the calculated surface area because a cooling canal system would require a system of parallel canals similar to that of Turkey Point. Applying the ratio of total land area compared to the evaporative surface

area at Turkey Point (1.74) to the calculated evaporative surface areas required at IPEC indicates that approximately 560 acres (Unit 2 or Unit 3) or 1120 acres (Units 2 and 3 combined) of land area would be required for a cooling canal system at IPEC.

### Conclusions

As discussed in Section 4.7.2, only 115 acres are currently available for use at IPEC because most of the site is already occupied. As such, the land area required for a closed re-circulating cooling canal system would be much greater than the land area available at IPEC. Therefore, the use of closed re-circulating cooling canals at IPEC is not further considered.

## 4.7.4 In-River Heat Exchangers

In-river heat exchangers are not considered as viable alternatives to the current screening systems at the Stations, because the use of in-river heat exchangers would be expected to present significant thermal biological issues.

In-river heat exchangers are a form of closed-loop cooling, whereby heat is rejected directly to the source water body without drawing an intake flow. As shown in Figure 4.28, an in-river heat exchanger works in three stages. First, the circulating water pump draws cold water across the condenser, condensing the main steam and increasing the temperature of the closed-loop flow. The hot recirculating water is then pumped from the condenser through a series of heat exchangers submerged in the source waterbody (i.e., in-river heat exchanger). The in-river heat exchanger allows heat to pass directly from the closed-loop cooling water to the flow of the river, and thus cool the closed-loop flow. After the circulating water has been cooled, it is drawn back to the condenser to close the cooling loop.

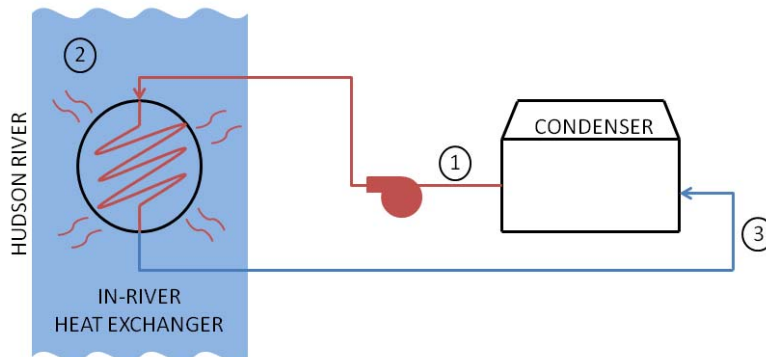

**Figure 4.28 Conceptual Diagram of In-River Heat Exchanger System**

At the Stations, in-river heat exchangers would encounter several site specific design challenges which would need to be addressed prior to determining feasibility. First, because the Hudson River is an estuary, the flow ebbs and floods and thus would not provide a constant cooling capacity, which would affect the operation of each Unit. During the transition periods between ebb and flood river flow (slack tide), the cooling capability of the in-river heat exchanger would be greatly reduced. Second, the in-river heat exchanger would need to be constructed of a material that would not corrode in the brackish Hudson River water. Materials suitable for use in brackish water typically are

more expensive and have a lower thermal conductivity than materials used in freshwater sources. Third, the in-river heat exchanger temperature would exceed the maximum SPDES plant discharge temperature permit limits [Ref. 6.86], particularly during slack tide.

Traditional cost-effective shell-and-tube heat exchangers seldom have temperature approaches less than 10°F [Ref. 6.77]. Because in-river heat exchangers at the Stations would not have a constant River cross flow rate and would be subject to corrosion and fouling performance limitations, it is assumed that in-river heat exchangers at the Stations would do no better than an approach of 10°F. However, this approach would be very optimistic based on the size required, operational considerations, and the variable flow conditions at the Stations. Complex heat exchanger configurations exist that could increase heat exchanger performance; however, the use of such configurations at IPEC would be limited by significant operational issues, including excessive fouling and pumping requirements. Lack of sufficient flow across the in-river heat exchangers could also lead to increased condenser back pressures and potential unplanned reactor shutdowns.

Based on historical river data collected at the Stations from 2001-2008, the maximum measured daily average circulating water inlet temperature is 83.8°F. At the maximum river temperature, the assumed 10°F temperature approach would result in a 93.8°F condenser inlet temperature. Similar to current once-through operation, the in-river heat exchanger system would be designed with a 17°F temperature rise over the condenser, based on the condenser BTU rejection requirements and 840,000 gpm flow rate. For context, at the maximum river temperature the condenser outlet temperature would be 110.8°F, exceeding the Stations' SPDES permit allowable discharge limit of 110°F [Ref. 6.86]. The in-river heat exchanger temperature would also exceed the SPDES permit limit of 93.2°F<sup>19</sup> between April 15 and June 30 for more than 15 days every year between 2001 and 2008, except 2003. Concurrently, the yearly average between 2001 and 2008 would exceed 10 days with an in-river heat exchanger temperature over 93.2°F.

### Conclusions

In comparison with the current once-through cooling design, an in-river heat exchanger system would inherently raise the condenser cooling water inlet and discharge temperatures. It is important to note that the in-river heat exchanger would require a large amount of surface area to dissipate the required heat load, and would create a large point source heat load in the Hudson River that would have no thermal dilution although heat dissipation through the Hudson River would occur. For context, the in-river heat exchanger temperature would exceed the maximum SPDES plant discharge temperature permit limits, particularly during periods of slack tide. In addition, operational issues associated with fouling and corrosion could present significant challenges. For these reasons, in-river heat exchanger closed-loop cooling systems would be expected to present

---

<sup>19</sup> Between April 15 and June 30, the maximum discharge temperature is limited by the SPDES permit to 93.2°F for an average of no more than ten days per year; provided that the daily average discharge temperature over this period does not exceed 93.2°F on more than 15 days in any year [Ref. 6.86].

significant thermal biological issues and are not further considered as alternatives to the current CWIS technologies.

## 5 Conclusions

Based on the feasibility and engineering evaluations documented in Section 4, Table 5.1 summarizes the various technologies and operational measures that were evaluated for biological compliance required by the NYSDEC in a draft modified SPDES permit.

**Table 5.1 Summary of Alternatives**

<b>Technology or Operational Measure</b>	<b>Comments</b>
<b>Existing CWIS Technologies and Operational Measures (Section 3)</b>	
Current Configuration	<p>Includes modified Ristroph-type traveling water screens, fish handling and return systems, low pressure screenwash systems, flow reductions due to dual/variable speed pump operation, flow reductions due to maintenance outages, and maintenance outage schedule considerations.</p> <p>Current reductions from Regulatory Baseline (Attachment 6):</p> <ul style="list-style-type: none"> <li>• EA1 Entrainment - approximately 33.8%</li> <li>• EA1 Impingement - approximately 80.2%</li> </ul>
<b>Fish Handling and Return Systems (Section 4.1)</b>	
Upgraded Fish Handling and Return System	<p>The existing fish return systems are considered to be state-of-the-art with respect to impingement losses and Siemens Water Technologies would not recommend any upgrades to the current fish return systems that would improve survivability rates.</p>
<b>Traveling Water Screens (Section 4.2)</b>	
Alternative Ristroph Screens (i.e., Ristroph screens with different mesh opening sizes than the mesh opening size of the existing Ristroph-type TWSs)	<p>Potential Reductions from Regulatory Baseline (Attachment 6):</p> <ul style="list-style-type: none"> <li>• EA1 Entrainment - up to 34.9%</li> <li>• EA1 Impingement - approximately 80.2%</li> </ul> <p>Potential Costs (2.0 mm mesh size):</p> <ul style="list-style-type: none"> <li>• Initial Costs - approximately \$373 million capital costs and approximately 3.9 million to 6.3 million MW-hrs per Unit of lost generation due to the required construction outages</li> <li>• Annual Costs - At a minimum, maintenance costs required would be at least 4 times the costs required to maintain the existing coarse mesh TWSs</li> </ul> <p>None of the mesh sizes evaluated would be expected to significantly reduce EA1 entrainment or EA1 impingement over the current screening systems.</p>



**Table 5.1 Summary of Alternatives**

<b>Technology or Operational Measure</b>	<b>Comments</b>
Dual Flow Traveling Water Screens	<p>Potential Reductions from Regulatory Baseline (Attachment 6):</p> <ul style="list-style-type: none"> <li>• EA1 Entrainment - up to 34.9%</li> <li>• EA1 Impingement - approximately 80.2%</li> </ul> <p>Potential Costs (2.0 mm mesh size):</p> <ul style="list-style-type: none"> <li>• Initial Costs – approximately \$350 million capital costs and approximately 4.7 million to 6.3 million MW-hrs per Unit of lost generation due to the required construction outages</li> <li>• Annual Costs - At a minimum, maintenance costs required would be at least 3 times the costs required to maintain the existing coarse mesh TWSs</li> </ul> <p>None of the mesh sizes evaluated would be expected to significantly reduce EA1 entrainment or EA1 impingement over the current screening systems.</p>
Angled Traveling Screens / Modular Inclined Screens	<p>Potential Reductions from Regulatory Baseline:</p> <ul style="list-style-type: none"> <li>• Similar to dual flow screens or Ristroph screens</li> </ul> <p>Potential Costs (2.0 mm mesh size):</p> <ul style="list-style-type: none"> <li>• Initial Costs - would be significantly higher than the costs associated with dual flow screens or Ristroph screens</li> <li>• Annual Costs - At a minimum, maintenance costs required would be 4 to 5 times the costs required to maintain the existing coarse mesh TWSs</li> </ul> <p>None of the mesh sizes evaluated would be expected to significantly reduce EA1 entrainment or EA1 impingement over the current screening systems.</p>
WIP Screens	<p>Potential Reductions from Regulatory Baseline:</p> <ul style="list-style-type: none"> <li>• Similar to dual flow screens or Ristroph screens</li> </ul> <p>Potential Costs (2.0 mm mesh size):</p> <ul style="list-style-type: none"> <li>• Initial Costs - would be significantly higher than the costs associated with dual flow screens or Ristroph screens</li> <li>• Annual Costs - At a minimum, maintenance costs required would be approximately 10 times the costs required to maintain the existing coarse mesh TWSs</li> </ul> <p>None of the mesh sizes evaluated would be expected to significantly reduce EA1 entrainment or EA1 impingement over the current screening systems.</p>
MultiDisc <sup>®</sup> Screens	<p>Potential Reductions from Regulatory Baseline:</p> <ul style="list-style-type: none"> <li>• Similar to dual flow screens or Ristroph screens</li> </ul> <p>Potential Costs (2.0 mm mesh size):</p> <ul style="list-style-type: none"> <li>• Initial Costs - would be significantly higher than the costs associated with dual flow screens or Ristroph screens</li> <li>• Annual Costs - At a minimum, maintenance costs required would be approximately 6 times the costs required to maintain the existing coarse mesh TWSs</li> </ul> <p>None of the mesh sizes evaluated would be expected to significantly reduce EA1 entrainment or EA1 impingement over the current screening systems.</p>

**Table 5.1 Summary of Alternatives**

Technology or Operational Measure	Comments
Passive Intake Systems (Section 4.3)	
Cylindrical Wedgewire Screens	<p>Potential Reductions from Regulatory Baseline (Through-Slot Velocity of 0.5 fps) (Attachment 6):</p> <ul style="list-style-type: none"> <li>• EA1 Entrainment - up to 89.8%</li> <li>• EA1 Impingement - approximately 99.9%</li> </ul> <p>Potential Costs:</p> <ul style="list-style-type: none"> <li>• Initial Costs <ul style="list-style-type: none"> <li>• approximately \$41.7 million for 2.0 mm screens, and approximately \$36.5 million for 9.0 mm CWW screens for a through-slot velocity of 0.5 fps</li> <li>• approximately \$63.3 million for 2.0 mm screens, and approximately \$52.0 million for 9.0 mm CWW screens for a through-slot velocity of 0.25 fps</li> <li>• resolution of unknown factors associated with the conceptual CWW system design would be required during the detailed design phase; these factors could, increase the total cost of implementing CWW screen systems to more than \$100 million</li> <li>• approximately 33,000 to 46,000 MW-hrs of lost generation due to the CW pump pit excavation and construction</li> </ul> </li> <li>• Annual Costs - At a minimum, maintenance costs would include the costs required to maintain the existing coarse mesh TWSs, the new airburst systems, and the new stop log systems, as well as the additional cost of divers as needed to clean/maintain the CWW screens</li> </ul> <p>In order to determine the optimal slot size for the Stations, a site-specific study would be required. A three-year site-specific engineering and biological effectiveness study would also be required to determine the optimum slot width for reducing EA1 entrainment losses at which fouling would not be a concern.</p>
Perforated Pipe Inlets	Perforated pipe intakes are obsolete and are have more engineering and operational difficulties than cylindrical wedgewire screens.
Porous Dikes / Leaky Dams	Porous dikes/leaky dams are not considered as viable alternatives to the current screening systems at the Stations due to nuclear safety concerns associated with possible clogging and reduced flow to safety-related SW pumps and the unproven nature of the technology at nuclear generating facilities.

**Table 5.1 Summary of Alternatives**

<b>Technology or Operational Measure</b>	<b>Comments</b>
<b>Barrier Technologies (Section 4.4)</b>	
Aquatic Filter Barriers	<p>Potential Reductions from Regulatory Baseline (Attachment 6):</p> <ul style="list-style-type: none"> <li>• EA1 Entrainment - approximately 90.2%</li> <li>• EA1 Impingement - approximately 90.4%</li> </ul> <p>Potential Costs:</p> <ul style="list-style-type: none"> <li>• Initial Costs - approximately \$67.4 million capital costs</li> <li>• Annual Costs - At a minimum, annual costs required would be approximately \$3 million for the O&amp;M and seasonal deployment, removal, and repair, not including the costs required to maintain the existing coarse mesh TWSs</li> </ul> <p>Aquatic filter barriers are not considered as the primary alternatives to the current intake screening system due to nuclear safety challenges associated with possible entanglement and reduced flow to safety-related SW pumps.</p>
Fish Barrier Nets	<p>Fish barrier nets are not considered as viable alternatives to the current screening systems due to nuclear safety challenges associated with possible entanglement and reduced flow to safety-related SW pumps and the lack of comparable reductions to closed-loop cooling or other alternative technologies.</p>
Behavioral Barriers (Light Guidance System, Acoustic Deterrents, Air Bubble Curtains, Electrical Barriers)	<p>Behavioral barriers are potentially technologically feasible, but additional study would be required because previous studies of behavioral barriers performed at the Stations and other sites have been inconclusive or have shown no significant reduction in impingement or entrainment. A site-specific study would be required to provide the optimal type, location, and configuration of any behavioral barriers.</p>
Louver System	<p>Louver systems are potentially technologically feasible, but additional study would be required to produce an optimized design for the Stations and determine the biological benefits. However, based on previous studied a louver system would not be expected to provide any appreciable reductions to entrainment or impingement.</p>
<b>Alternate Intake Location (Section 4.5)</b>	
Alternate Intake Location	<p>Retrofit to an alternative intake location is potentially technologically feasible, but additional study would be required because IPEC site-specific biological information does not provide the optimal location or depth for an offshore intake.</p>
<b>Flow Reduction (Section 4.6)</b>	
Dual / Variable Speed Pumps	<p>The maximum available reductions from baseline in EA1 entrainment and impingement associated with reductions in the design flow rates would be approximately 49.9% and 85.0%, respectively. These reductions would not be comparable to those potentially achievable by conversion to closed-loop cooling, and a significant cost would be associated with the active power reductions resulting from the flow reductions.</p>

**Table 5.1 Summary of Alternatives**

<b>Technology or Operational Measure</b>	<b>Comments</b>
Use of Recycled Wastewater as Cooling Water	Use of recycled wastewater is technologically infeasible due to limited sources of grey water in the vicinity of IPEC.
Outage Timing	The maximum incremental reduction in EA1 entrainment (2.6%) and EA1 impingement (1.2%) would result from a shift in scheduled outage timing to September. As such, a change in the current schedule outage timing is not further considered as an alternative to the current technologies and operational measures.
Radial Wells	Use of radial wells is technologically infeasible due to limited sources of available groundwater and land space at IPEC.
<b>Alternative Heat Rejection and Recirculation (Section 4.7)</b>	
Evaporation Ponds	Use of evaporative ponds is technologically infeasible due to limited land space at IPEC.
Spray Ponds	Use of spray ponds is technologically infeasible due to limited land space at IPEC.
Cooling Canals	Use of cooling canals is technologically infeasible due to limited land space at IPEC.
In-River Heat Exchangers	In-river heat exchanger closed-loop cooling systems would be expected to present significant thermal biological issues. For context, in-river heat exchanger temperatures would exceed the maximum SPDES plant discharge temperature permit limits, particularly during periods of slack tide.

As shown in Table 5.1, CWW screens have the potential to achieve reductions in I&E at the Stations comparable to the NYSDEC Proposed Project and are considered to be the primary alternative. As discussed in Section 4.3.1, cylindrical wedgewire screens have been implemented at a facility with a total intake flow rate comparable to the total intake flow rate at the Stations.<sup>20</sup>

Several conceptual cylindrical wedgewire screening array designs, each fitting within the Stations' exclusionary zone, were created. Although EPA typically recommends cylindrical wedgewire through-slot velocities at or below 0.5 feet per second (fps), NYSDEC has indicated interest in through-slot velocities at or below 0.25 fps. As such, separate conceptual cylindrical wedgewire screen systems were designed to provide a maximum through-slot velocity of at or below both 0.5 fps and 0.25 fps. The estimated capital costs associated with the installation of the conceptual CWW screen designs discussed in Section 4.3.1 would be:

- Approximately \$41.7 million for 2.0 mm screens, and approximately \$36.5 million for 9.0 mm CWW screens for a through-slot velocity of 0.5 fps.

<sup>20</sup> Oak Creek Power Plant in Milwaukee, Wisconsin operates the largest installation of cylindrical wedgewire screens, which includes an offshore intake system that filters a flow rate of 1,560,000 gpm. The cylindrical wedgewire screen system at Oak Creek became operational in January 2009 and is designed to operate year round.

- Approximately \$63.3 million for 2.0 mm screens, and approximately \$52.0 million for 9.0 mm CWW screens for a through-slot velocity of 0.25 fps.

As described in Section 4.3.1, several unknown factors associated with the conceptual CWW system design developed in this Report would require resolution during the detailed design phase. These factors could more than double the costs, increasing the total cost of implementing CWW screen systems to more than \$100 million. There would also be potentially 33,000 to 46,000 MW-hrs of lost generation due to the required CW pump pit excavation and construction for both Units. Each of the slot sizes evaluated would be expected to achieve comparable reductions in EA1 I&E to the NYSDEC Proposed Project. Specifically, operation of cylindrical wedgewire screens with a mesh size of 2.0 mm and through-slot velocity at or below 0.5 fps has the potential to reduce EA1 I&E from the regulatory baseline by as much as approximately 99.9% and 89.8%, respectively. In addition, according to Attachment 6, the estimated cumulative total reduction in EA1 I&E for CWW screens (98% and 87% for EA1 impingement and entrainment losses, respectively) would be greater than the estimated cumulative total reduction in EA1 I&E for the NYSDEC Proposed Project (86% and 50% for EA1 impingement and entrainment losses, respectively).<sup>21</sup> Because CWW screens with smaller slot sizes would create significant opportunity for fouling, slot sizes ranging from 2.0 mm to 9.0 mm were selected for initial evaluation in an attempt to minimize both entrainment and fouling. Before cylindrical wedgewire screens can be implemented at the Stations, a site-specific study would be required to determine the optimal slot width for reducing entrainment at which fouling would not be a concern.

---

<sup>21</sup> For the cumulative benefits analysis, the installation schedule for CWW screens is consistent with a proposal based on studies of the technology, as discussed in Attachment 6. The installation schedule for the NYSDEC Proposed Project was derived by ENERCON [Ref. 6.22] with input from counsel to Entergy and Spectra Energy Transmission (owner of the gas pipeline that would have to be re-located in order to construct the NYSDEC Proposed Project).

## 6 References

- 6.1 40 CFR Part 125. Code of Federal Regulations, Title 40, Protection of Environment, Part 125, Criteria and Standards for the National Pollutant Discharge Elimination System.
- 6.2 American Society of Civil Engineers. Design of Water Intake Structure for Fish Protection. 1982.
- 6.3 ASA Analysis & Communication, Inc. Gunderboom MLES<sup>TM</sup> Evaluation Study at the Lovett Generating Station, January 2006.
- 6.4 Blumberg, A.F., “Hydrodynamics of the Hudson River Estuary.” American Fisheries Society Symposium 51, September 18, 2006.
- 6.5 Blumberg, A.F., Dunning, D.J., Li, H., Heimbuch, D, and Geyer, W.R. “Use of a Particle-tracking Model for Predicting Entrainment at Power Plants on the Hudson River.” Estuaries. Vol. 27. No. 3. pp. 515-526. 2004.
- 6.6 Carolina Power & Light. Brunswick Nuclear Plant. 2000 Environmental Monitoring Report. August 2001.
- 6.7 Carolina Power & Light. Brunswick Nuclear Plant. Updated FSAR, Units 1 and 2. Rev. 21.
- 6.8 Central Hudson Gas & Electric Corp. Consolidated Edison Company of New York, Inc., New York Power Authority, and Southern Entergy New York. Draft Environmental Impact Statement. December 1999.
- 6.9 Consolidated Edison Company of New York, Inc. and New York Power Authority. Document Number IP-RPT-04-00270. Indian Point Units 2 and 3 Ristroph Screen Return System Prototype Evaluation and Siting Study. November 1992.
- 6.10 Curtin, M., Acoustic Barriers for Grass Carp. Proceedings of the Grass Carp Symposium. Gainesville, FL. 1994.
- 6.11 Dragos, P. and W. R. Geyer. Entrainment of passive particles into Hudson River power plants: Data report for the low-discharge condition survey. Prepared for Orange and Rockland Utilities, Inc., Pearl River, NY. Prepared by Coastal Oceanographic Associates, Sandwich, Massachusetts. 1998.
- 6.12 Electric Power Research Institute. Beaudrey Water Intake Protection (WIP) Screen Pilot-Scale Impingement Survival Study. Technical Report 1018490. Palo Alto, CA. 2009.
- 6.13 Electric Power Research Institute. Biological Evaluation of a Modular Inclined Screen for Protecting Fish at Water Intakes. Technical Report 104121. Palo Alto, CA. 1994.

- 6.14** Electric Power Research Institute. Chapter 1: Traveling Water Screens. Technical Report 1011546. Palo Alto, CA. 2004.
- 6.15** Electric Power Research Institute. Chapter 22: Behavioral Methods, Fish Passage Manual Chapter Updates. Technical Report 1011448. Palo Alto, CA. 2004.
- 6.16** Electric Power Research Institute. Design Considerations and Specifications for Fish Barrier Net Deployment at Cooling Water Intake Structures. Technical Report 1013309. Palo Alto, CA. 2006.
- 6.17** Electric Power Research Institute. Field Testing of Behavioral Barriers for Fish Exclusion at Cooling Water Intake Systems. CS-5995. Palo Alto, CA. 1988.
- 6.18** Electric Power Research Institute. Fish Protection at Cooling Water Intakes: Status Report. Technical Report 114013. Palo Alto, CA. 1999.
- 6.19** Electric Power Research Institute. Laboratory Evaluation of an Aquatic Filter Barrier (AFB) for Protecting Early Life Stages of Fish. Technical Report 1005534. Palo Alto, CA. December 2004.
- 6.20** Electric Power Research Institute. Laboratory Evaluation of Wedgewire Screens for Protecting Early Life Stages of Fish at Cooling Water Intakes. Technical Report 1005339. Palo Alto, CA. May 2003.
- 6.21** Empire State Electric Energy Research Corporation: New York Power Authority, Normandeau Associates, Inc., Sonalysts, Inc. Acoustic Fish Deterrents Research Report. EP 89-30. April 1991.
- 6.22** Enercon Services, Inc. Engineering Feasibility and Costs of Conversion of Indian Point Units 2 and 3 to a Closed-Loop Condenser Cooling Water Configuration. 2010.
- 6.23** Entergy Arkansas, Inc. Arkansas Nuclear One Units 1 and 2. Safety Analysis Report. Amendment 22.
- 6.24** Entergy Nuclear Operations, Inc. “Applicant’s Environmental Report, Operating License Renewal Stage (Appendix E to Indian Point, Units 2 & 3, License Renewal Application).” ADAMS Accession No. ML071210530. April 23, 2007.
- 6.25** Entergy Nuclear Operations, Inc. Procedure EN-DC-114. Project Management. Rev. 10. June 12, 2009.
- 6.26** Environment Agency, “Screening for Intake and Outfalls: A Best Practice Guide”, Science Report SC030231, February 2005, pp. 88-90.
- 6.27** Envirex, Inc., Fine Screen Evaluation, January 19, 1993.
- 6.28** Feist, B.E., Anderson, J.J. Review of Fish Behavior in Response to Fish Guidance Systems. Fisheries Research Institute. March 1991.

- 6.29** Fish Guidance Systems Ltd. Southampton, UK. <http://www.fish-guide.com>. Accessed January 29, 2010.
- 6.30** Flash Technology, an SPX Division. Lighting: Products. 2008. <http://flashtechonology.com/lighting/products>. Accessed January 29, 2010.
- 6.31** Fletcher, R. I. A Review of Reported Fine Mesh Screen Applications for High Volume Water-Intake Systems and Recommendations for Further Investigations. July 1990.
- 6.32** Fletcher, R. I. Comments of Fine-Mesh Investigations as Reported in the Draft Environmental Impact Station. January 1994.
- 6.33** Fletcher, R. I. Flow Dynamics and Fish Recovery Experiments: Water Intake Systems, Transactions of the American Fisheries Society. Vol. 119. No. 3. pp. 393-415. May 1990.
- 6.34** Fletcher, R. I. Hydraulic and Mechanical Considerations, an Addendum to a Review of Reported Fine Mesh Screen Applications for High Volume Water-Intake Systems and Recommendations for Further Investigations. July 1990.
- 6.35** Fletcher, R. I. Risk Analysis for Fish Diversion Experiments: Pumped Intake Systems. 1985.
- 6.36** Florida Power and Light. Generic Environmental Impact Statement for License Renewal of Nuclear Plants, Turkey Point Plant, Units 3 and 4. NUREG-1437. Supplement 5. 2002
- 6.37** GZA GeoEnvironmental, Inc. Hydrogeologic Site Investigation Report. January 2009.
- 6.38** Heat Exchange Institute. Standards for Steam Surface Condensers. 10<sup>th</sup> Edition. 2006.
- 6.39** Heuer and Tomljanovich. A Study of the Protection of Fish Larva at Water Intakes using Wedge-Wire Screening. 1978.
- 6.40** Hudson River Settlement Agreement. Stipulation of Settlement and Judicial Consent Order, In the Matter of the Application of NRDC, Inc. v. NYSDEC et al., No. 6570-91. Sup. Ct. Albany. March 23, 1992.
- 6.41** Indian Point Energy Center. Document Number TS-Q-12.302. Vendor Manual, Traveling Water Screens – IP2 Circ. Water Screens 21 to 26. Envirex Inc. Rev. 3. 1998.
- 6.42** Indian Point Energy Center. Condenser Data Sheets. Foster Wheeler Energy Corporation. FW Contract Numbers 4-87-5883 and 4-87-4877.
- 6.43** Indian Point Energy Center. Drawing 138110-05. Concrete – Discharge Tunnel & Service Building Plan, Elevations, & Details. Rev. 5. 1959.



- 6.44** Indian Point Energy Center. Drawing 138113-10. Concrete – Discharge Tunnel Plan, Elevations, & Details, Sheet No. 3. Rev 10. 1978.
- 6.45** Indian Point Energy Center. Drawing 9321-F-10073.04. Construction Sheet Piling Layout. Rev. 4. 2001.
- 6.46** Indian Point Energy Center. Drawing 9321-F-1010, Intake Structure Concrete – Bottom Slab Plan. Rev. 11.
- 6.47** Indian Point Energy Center. Drawing 9321-F-10103, Intake Structure Concrete – Bottom Slab Plan. Rev. 3.
- 6.48** Indian Point Energy Center. Drawing 9321-F-1012-14. Intake Structure Concrete – Plan Thru Walls. Rev. 14. 2001.
- 6.49** Indian Point Energy Center. Drawing 9321-F-1013-18. Intake Structure Concrete – Cross Sections. Rev. 18. 2001.
- 6.50** Indian Point Energy Center. Drawing 9321-F-1111-06. Discharge Water Tunnel West Portion, Sheet No. 1. Rev. 6. 2001.
- 6.51** Indian Point Energy Center. Drawing 9321-F-1114-3. Discharge Water Tunnel East Portion, Sheet No. 2. Rev. 3. 1973.
- 6.52** Indian Point Energy Center. Drawing 9321-F-11143-01. Discharge Water Tunnel East Portion, Sheet No. 2. Rev. 1. 1975.
- 6.53** Indian Point Energy Center. Drawing 9321-F-13333-03. Discharge Canal Plan and Permanent Sheet Piling Bulkheads. Rev. 3. 1975.
- 6.54** Indian Point Energy Center. Drawing 9321-F-20010. Ristroph Traveling Screens Intake Structure Fish & Debris Troughs Plans. Rev. 3. 2001.
- 6.55** Indian Point Energy Center. Drawing 9321-F-20011. Ristroph Traveling Screens Intake Structure Fish & Debris Troughs Elevs, Sections & Details Mechanical. Rev. 1. 1993.
- 6.56** Indian Point Energy Center. Drawing A182528 and A182529, Indian Point 1, 2, & 3 Screen Wash Water Sluice Flume Plans.
- 6.57** Indian Point Energy Center. Drawing D169372-12. Riverwater Cooling Water and Service Water System – Unit #1. Rev. 12. 1965.
- 6.58** Indian Point Energy Center. Indian Point 2. Service Water System Operation, 2-SOP 24.1. Rev. 56. 2005.
- 6.59** Indian Point Energy Center. Indian Point 2. System Description 24.0, Service Water Systems.

- 6.60** Indian Point Energy Center. Indian Point 2 UFSAR. Rev. 21. 2008.
- 6.61** Indian Point Energy Center. Indian Point 3. Procedure 3-SOP-RW-002. Intake Structure Operation. Rev. 24. 2008.
- 6.62** Indian Point Energy Center. Indian Point 3. System Description 22. Intake Structure. Rev. 4. 2005.
- 6.63** Indian Point Energy Center. Indian Point 3. System Description 23.0 – Circulating Water System. Rev. 4.
- 6.64** Indian Point Energy Center. Indian Point 3 UFSAR. Rev. 3. 2009.
- 6.65** Indian Point Energy Center. Procedure 2-ARP-SDF. Turbine Recorder. Rev. 24. 2007.
- 6.66** Indian Point Energy Center. Procedure 3-ARP-007. Panel SDF – Turbine Recorder. Rev. 27. 2009.
- 6.67** Institute of Nuclear Power Operations. SOER 07-2 Intake Cooling Water Blockage. December 2007.
- 6.68** James A. Fitzpatrick Nuclear Power Plant (JAF), Updated Final Safety Analysis Report Update. 2007.
- 6.69** Ketschke, B.A. “Use of a Porous Dike to Reduce Entrainment and Entrapment in Power Plant Cooling Water Systems.” Coastal Zone ’80 Vol. I. ASCE. New York. 1980.
- 6.70** Langford, T.E. Ecological Effects of Thermal Discharges. Springer. 1990.
- 6.71** LaSalle Hydraulic Laboratory, LTD. Hydraulic Model Study of Hudson River Flows Around Cooling Water Intakes. November 1976.
- 6.72** Lawler, Matuskey and Skelly Engineers, LLC, Lovett Generating Station Gunderboom Evaluation Program 1996, May 1997.
- 6.73** Lawler, Matuskey and Skelly Engineers, LLC, Lovett Generating Station Gunderboom Evaluation Program 1997, March 1998.
- 6.74** Lawler, Matuskey and Skelly Engineers, LLC, Lovett Generating Station Gunderboom Evaluation Program 1998, December 1998.
- 6.75** Laws, E.A., Aquatic Pollution: An Introductory Text. John Wiley and Sons. 2000.
- 6.76** Lawton, R.P., et al. Annual report on assessment and mitigation impact of the Pilgrim Nuclear Power Station on finfish populations in western Cape Cod Bay. Project Report No. 68 (Jan. – Dec. 1999). In: Marine Ecology Studies Related to the

- Operation of Pilgrim Station, Semiannual Report No. 55. Entergy Nuclear Generation Company, Plymouth, MA. 2000.
- 6.77** Lindeburg, M. R. Mechanical Engineering Reference Manual for the PE Exam. 12<sup>th</sup> Edition. Professional Publications, Inc. Belmont, CA. 2006.
- 6.78** Maes, J., et al. Field Evaluation of a Sound System to Reduce Estuarine Fish Intake Rates at a Power Plant Cooling Water Intake. *Journal of Fish Biology* 64 (2004): 938-946.
- 6.79** Marcellus, K.L., Young, J. Evaluation of the Effectiveness of Pneumatic Poppers to Reduce Fish Impingement at Indian Point Unit 2. Consolidated Edison Company of New York, Inc. October 1987.
- 6.80** National Estuarine Research Reserve System. Hudson River Bathymetry Depth in Meters. [http://hrnerr.org/public/Benthic/bathy/GE\\_hudson\\_bathy.html](http://hrnerr.org/public/Benthic/bathy/GE_hudson_bathy.html). Accessed January 29, 2010.
- 6.81** National Oceanic and Atmospheric Administration. Elevations on Station Datum, Haverstraw Bay, NY. Station ID 8518924. [http://tidesandcurrents.noaa.gov/data\\_menu.shtml?stn=8518924%20HAVERSTRAW%20BAY,%20NY&type=Datums,%20accessed%2018%20December%202009](http://tidesandcurrents.noaa.gov/data_menu.shtml?stn=8518924%20HAVERSTRAW%20BAY,%20NY&type=Datums,%20accessed%2018%20December%202009). Accessed December 18, 2009.
- 6.82** National Oceanic and Atmospheric Administration. Nautical Chart 12343. Edition 19. October 2005. <http://www.charts.noaa.gov/OnLineViewer/12343.shtml>. Accessed January 29, 2010.
- 6.83** Nebraska Public Power District. Applicant's Environmental Report, Operating License Renewal Stage, Cooper Nuclear Station (Appendix E to Cooper Nuclear Station, License Renewal Application). September 30, 2008.
- 6.84** NERA Economic Consulting. Economic Comments on Nuclear Regulatory Commission DSEIS for Indian Point Energy Center. March 2009.
- 6.85** New York Independent System Operator. Outage Schedule Manual. Rev. 2. November 2, 2004.
- 6.86** New York State Department of Environmental Conservation. New York State Pollutant Discharge Elimination System (SPDES) Discharge Permit. SPDES Permit Number: NY-0004472. Entergy Nuclear Indian Point Units #2 and #3 LLC.
- 6.87** New York State Department of Environmental Conservation. New York State Pollutant Discharge Elimination System (SPDES) Discharge Permit. SPDES Permit Number: NY-0020109. Entergy Nuclear FitzPatrick LLC.

- 6.88** New York State Department of Environmental Conservation. Final Environmental Impact Statement Concerning the Applications to Renew New York State Pollutant Discharge Elimination System (SPDES) Permits for the Roseton 1 & 2, Bowline 1 & 2, and Indian Point 2 & 3. Mitigation 7. Accepted June 25, 2003.  
<http://www.dec.ny.gov/permits/54649.html>. Accessed January 27, 2010.
- 6.89** New York State Department of Environmental Conservation. Fourth Amended Stipulation of Settlement and Judicial Consent Order, National Resources Defense Council, Inc. et. al. vs. New York State Department of Environmental Conservation and Consolidated Edison Company of New York, Inc, New York Power Authority, Orange and Rockland Utilities, Inc., and Central Hudson Gas and Electric Corp. 1997.
- 6.90** New York State Department of Environmental Conservation. Interim Decision of the Assistant Commissioner In the Matter of a Renewal and Modification of a State Pollutant Discharge Elimination System (“SPDES”) permit pursuant to Environmental Conservation Law (“ECL”) Article 17 and Title 6 of the Official Compilation of Codes, Rules and Regulations of the State of New York (“6 NYCRR”) Parts 704 and 750 et seq. by Entergy Nuclear Indian Point 2, LLC and Entergy Nuclear Indian Point 3, LLC, Permittee. DEC No: 3-5522-00011/00004. August 13, 2008.
- 6.91** New York State Department of Environmental Conservation: Stark, Lynette M. “Re: Determination of Best Technology Available for “Existing Facilities” in New York”. Letter to Benjamin Grumbles, United States Environmental Protection Agency. January 24, 2005.
- 6.92** New York State Energy Research and Development Authority. Annual report on Disposition of Real and Personal Property (April 1, 2006 – March 31, 2007), Pursuant to Section 2896 of the Public Authorities Law.
- 6.93** Normandeau Associates, Inc. Revised Study Plan to Perform Biological Monitoring to Assess Extension of the Cooling Water Intake Structure at the James A. FitzPatrick Nuclear Power Plant as Specified in SPDES Permit No. NY 0020109 (Effective 08/01/2008). April 2009.
- 6.94** Pankratz, Tom, P. Screening Equipment Handbook. Technomic Publishing Company, Inc. 1995.
- 6.95** Parkinson, F.E., and Goulet, F. “Hydraulic Model Study of Hudson River Flows Around Cooling Water Intakes”. La Salle Hydraulic Laboratory Report 682 for Consolidated Edison Company of New York. November 1976.
- 6.96** Passavant Geiger. Geiger MultiDisc® Screen Brochure. Karlsruhe, Germany. 2008.
- 6.97** Pfafflin, J.R. and Ziegler, E.N., Encyclopedia of Environmental Science and Engineering: Volume I. CRC Press. 2006.

- 6.98** Pilgrim Nuclear Power Station. Entergy Nuclear Generation Company. Marine ecological studies Pilgrim Nuclear Power Station Report 69. Report Period January 2006 – December 2006. 2007.
- 6.99** Raffenburg, Matthew J. et.al. Development of Filter Fabric Technology Determined to be BTA for Minimizing Environmental Impacts at Power Generating Facilities. 2002.
- 6.100** Ranney Collector Wells. <http://www.collectorwells.com/projects.html>. Accessed January 29, 2010.
- 6.101** Richards, R.T. and Hroncich, M.J. “Perforated Pipe Water Intake for Fish Protection.” Journal of the Hydraulics Division. ASCE. Vol. 102 No. HY 2. pp 136-149. February 1976.
- 6.102** Rooks, J. A., and Wallace, A. K. Energy Efficiency of VSDs. IEEE Industry Applications Magazine. Pp. 57-61. May/June 2004.
- 6.103** Saxon, G., Jr., and Howell, A. The Practical Application & Innovation of Cleaning Technology for Condensers. ASME Power Division Special Section. August 2005.
- 6.104** Smith-Root, Inc. Electric Barriers and Guidance Systems. 2007. <http://www.smith-root.com/barriers>. Accessed January 29, 2010.
- 6.105** South Texas Project Nuclear Operating Company. South Texas Project Units 3 and 4 COLA Environmental Report. 2008.
- 6.106** Spraying Systems Co. Spray Ponds for Cooling and Evaporation. Technical Manual No. 401A.
- 6.107** Taft, E., Garnett, G., Amaral, S. Alden Research Laboratory, Fish Protection Technologies: Status Report. Presented at EPRI Power Generation Impacts on Aquatic Resources Conference. April 1999.
- 6.108** Texas Instruments Incorporated Ecological Services. Indian Point Impingement Study Report for the Period 15 June 1972 through 31 December 1973. December 1974.
- 6.109** Texas Instruments Incorporated Ecological Services. Indian Point Impingement Study Report for the Period 1 January 1974 through 31 December 1974. November 1975.
- 6.110** Tomichek, C. Evaluation of Angled Bar Racks and Louvers for Guiding Fish at Water Intakes. October 2001.
- 6.111** United Engineers & Constructors Inc. Indian Point Unit No. 2 Ristroph Screen Debris/Fish Return System Discharge Site Feasibility Study. November 1992.
- 6.112** United States Army Corps of Engineers. Ice Blockage of Intake Trash Racks. Cold Regions Technical Digest. No. 91-1. March 1991.

- 6.113** United States Department of Energy. Cost Estimating Guide. Publication No. DOE G 430.1-1. March 28, 1997.
- 6.114** United States Environmental Protection Agency, 40 CFR Parts 9, 122, 123, et al., National Pollutant Discharge Elimination System; Cooling Water Intake Structures for New Facilities; Proposed Rules.
- 6.115** United States Environmental Protection Agency. Technical Development Document for the Final Section 316(b) Phase II Existing Facilities Rule. Washington, DC. February 12, 2004.
- 6.116** United States Fish and Wildlife Service. Significant Habitats and Habitat Complexes of the New York Bight Watershed, Hudson River Estuary, Habitat Complex 32, Lower Hudson River. 1997.
- 6.117** United States Geological Survey. Ground Water Atlas of the United States, Segment 12. 1995.
- 6.118** United States Geological Survey. National Wetlands Research Center Digital Library. Species Profiles: Life Histories and Environmental Requirements of Coastal Fishes and Invertebrates – List by Species Name. <http://www.nwrc.usgs.gov/publications/specindex.htm#S>. Accessed January 29, 2010.
- 6.119** United States Nuclear Regulatory Commission. Generic Environmental Impact Statement for License Renewal of Nuclear Plants Supplement 38 Regarding Indian Point Nuclear Generating Unit Nos. 2 and 3 Draft Report for Comment, NUREG-1437 Volume 1 Supplement 38. December 2008
- 6.120** United States Nuclear Regulatory Commission. Pressurized Water Reactor (PWR) Systems, “Nuclear Reactor Concepts” Workshop Manual. <http://www.nrc.gov/reading-rm/basic-ref/teachers/04.pdf>. Accessed January 29, 2010.
- 6.121** Wang, L., Pereira, N., Hung, Y, and Li, K. Advanced Air and Noise Pollution Control. Volume II. Springer. 2004.