



**PART I.A. Effluent Limitations and Monitoring Requirements**

1. During the period beginning on the effective date and lasting through expiration, the permittee is authorized to discharge reverse osmosis (RO) reject water from outfall serial number <b>001</b> . Such discharges shall be limited and monitored by the permittee as specified below:				
<u>EFFLUENT CHARACTERISTIC</u>		<u>EFFLUENT LIMITS</u>		<u>MONITORING REQUIREMENTS</u>
<u>PARAMETER</u>	<u>AVERAGE MONTHLY</u>	<u>MAXIMUM DAILY</u>	<u>MEASUREMENT FREQUENCY</u>	<u>SAMPLE<sup>1</sup> TYPE</u>
Flow <sup>2</sup>	66,000 GPD	120,000 GPD	Continuous	Recorder
pH Range <sup>3</sup>	6.5 – 9.0 s.u.		1/Week	Grab
Dissolved Oxygen <sup>3</sup>	Not less than 6.0 mg/l		1/Month	Grab
Total Suspended Solids	Report mg/l	Report mg/l	1/Quarter <sup>4</sup>	Grab
Total Ammonia Nitrogen	Report µg/l	Report µg/l	1/Month	Grab
Total Residual Chlorine	Report µg/l	Report µg/l	1/Month	Grab
Copper, Total	Report µg/l	Report µg/l	1/Quarter <sup>4</sup>	Grab

The discharge of wastewaters to the Charles River from any and all cleaning or backwashing of these RO units or any of their components is prohibited.

Footnotes:

1. Sampling shall be conducted at a point prior to discharge to Outfall 001 and prior to mixing with any other stream. Any change in sampling location must be reviewed and approved in writing by EPA and MassDEP. All samples shall be tested using the analytical methods found in 40 CFR §136, or alternative methods approved by EPA in accordance with the procedures in 40 CFR §136.
2. The flow shall be continuously measured and recorded using a flow meter.
3. Requirement for State Certification. For pH, the minimum and maximum values for each month shall be reported.
4. The quarterly monitoring shall be conducted during the months of February, May, August, and November.

## Part I.A.1. (continued)

- a. The discharge shall not cause a violation of the water quality standards of the receiving waters.
- b. The effluent pH shall be in the range of 6.5 through 9.0 standard units.
- c. The discharge shall not cause objectionable discoloration of the receiving waters.
- d. The effluent shall contain neither a visible oil sheen, foam, nor floating solids at any time.
- e. The results of sampling for any parameter above its required frequency must also be reported.

## 2. Toxics Control

- a. The permittee shall not discharge any pollutant or combination of pollutants in toxic amounts.
- b. Any toxic components of the effluent shall not result in any demonstrable harm to aquatic life or violate any state or federal water quality standard which has been or may be promulgated. Upon promulgation of any such standard, this permit may be revised or amended in accordance with such standards.

## 3. Numerical Effluent Limitations for Toxicants

EPA or MassDEP may use the results of the chemical analyses conducted pursuant to this permit, as well as national water quality criteria developed pursuant to Section 304(a)(1) of the Clean Water Act (CWA), state water quality criteria, and any other appropriate information or data, to develop numerical effluent limitations for any pollutants, including but not limited to those pollutants listed in Appendix D of 40 CFR Part 122.

4. All existing manufacturing, commercial, mining, and silvicultural dischargers must notify the Director as soon as they know or have reason to believe:
  - a. That any activity has occurred or will occur which would result in the discharge, on a routine or frequent basis, of any toxic pollutant which is not limited in the permit, if that discharge will exceed the highest of the following "notification levels":
    - (1) One hundred micrograms per liter (100 µg/l);
    - (2) Two hundred micrograms per liter (200 µg/l) for acrolein and acrylonitrile; five hundred micrograms per liter (500 µg/l) for 2,4-dinitrophenol and for 2-methyl-4,6-dinitrophenol; and one milligram per liter (1 mg/l) for antimony;

- (3) Five (5) times the maximum concentration value reported for that pollutant in the permit application in accordance with 40 C.F.R. §122.21(g)(7); or
  - (4) Any other notification level established by the Director in accordance with 40 C.F.R. §122.44(f).
- b. That any activity has occurred or will occur which would result in the discharge, on a non-routine or infrequent basis, of any toxic pollutant which is not limited in the permit, if that discharge will exceed the highest of the following "notification levels":
- (1) Five hundred micrograms per liter (500 µg/l);
  - (2) One milligram per liter (1 mg/l) for antimony;
  - (3) Ten (10) times the maximum concentration value reported for that pollutant in the permit application in accordance with 40 C.F.R. §122.21(g)(7); or
  - (4) Any other notification level established by the Director in accordance with 40 C.F.R. §122.44(f).
- c. That they have begun or expect to begin to use or manufacture as an intermediate or final product or byproduct any toxic pollutant which was not reported in the permit application.
5. This permit may be modified, or revoked and reissued, on the basis of new information in accordance with 40 CFR §122.62.

## **B. UNAUTHORIZED DISCHARGES**

The permittee is authorized to discharge only in accordance with the terms and conditions of this permit and only from the outfall listed in Part I A.1. of this permit. Discharges of wastewater from any other point sources are not authorized by this permit and shall be reported in accordance with Section D.1.e. (1) of the General Requirements (Part II) of this permit (Twenty-four hour reporting).

## **C. REOPENER CLAUSE**

This permit shall be modified, or alternately, revoked and reissued, to comply with any applicable standard or limitation promulgated or approved under sections 301(b)(2)(C) and (D), 304(b)(2), and 307(a)(2) of the Clean Water Act, if the effluent standard or limitation so issued or approved:

- a. Contains different conditions or is otherwise more stringent than any effluent limitation in the permit; or
- b. Controls any pollutants not limited in the permit.

## D. MONITORING AND REPORTING

The monitoring program in the permit specifies sampling and analysis, which will provide continuous information on compliance and the reliability and effectiveness of the installed pollution abatement equipment. The approved analytical procedures found in 40 CFR Part 136 are required unless other procedures are explicitly required in the permit. The Permittee is obligated to monitor and report sampling results to EPA and the MassDEP within the time specified within the permit.

Unless otherwise specified in this permit, the permittee shall submit reports, requests, and information and provide notices in the manner described in this section.

### 1. Submittal of DMRs and the Use of NetDMR

**Beginning the effective date of the permit** the permittee must submit its monthly monitoring data in discharge monitoring reports (DMRs) to EPA and MassDEP no later than the 15th day of the month following the completed reporting period. **For a period of six months from the effective date of the permit**, the permittee may submit its monthly monitoring data in discharge monitoring reports (DMRs) to EPA and MassDEP either in hard copy form, as described in Part I.D.4, or in DMRs electronically submitted using NetDMR. NetDMR is a web-based tool that allows permittees to electronically submit DMRs and other required reports via a secure internet connection. NetDMR is accessed from: <http://www.epa.gov/netdmr>. **Beginning no later than six months after the effective date of the permit**, the permittee shall begin reporting monthly monitoring data using NetDMR, unless, in accordance with Part I.D.6, the facility is able to demonstrate a reasonable basis, such as technical or administrative infeasibility, that precludes the use of NetDMR for submitting DMRs. The permittee must continue to use the NetDMR after the permittee begins to do so. When a permittee begins submitting reports using NetDMR, it will no longer be required to submit hard copies of DMRs to EPA or MassDEP.

### 2. Submittal of Reports as NetDMR Attachments

After the permittee begins submitting DMR reports to EPA electronically using NetDMR, the permittee shall electronically submit all reports to EPA as NetDMR attachments rather than as hard copies, unless otherwise specified in this permit. Permittees shall continue to send hard copies of reports other than DMRs to MassDEP until further notice from MassDEP. (See Part I.D.5. for more information on state reporting.) Because the due dates for reports described in this permit may not coincide with the due date for submitting DMRs (which is no later than the 15<sup>th</sup> day of the month), a report submitted electronically as a NetDMR attachment shall be considered timely if it is electronically submitted to EPA using NetDMR with the next DMR due following the particular report due date specified in this permit.

3. Submittal of Requests and Reports to EPA/OEP

The following requests, reports, and information described in this permit shall be submitted to the EPA/OEP NPDES Applications Coordinator in the EPA Office Ecosystem Protection (OEP).

- A. Transfer of Permit notice
- B. Request for changes in sampling location
- C. Notification of proposal to add or replace chemicals and bio-remedial agents including microbes

These reports, information, and requests shall be submitted to EPA/OEP electronically at [R1NPDES.Notices.OEP@epa.gov](mailto:R1NPDES.Notices.OEP@epa.gov) or by hard copy mail to the following address

**U.S. Environmental Protection Agency  
Office of Ecosystem Protection  
EPA/OEP NPDES Applications Coordinator  
5 Post Office Square - Suite 100 (OEP 06-03)  
Boston, MA 02109-3912**

4. Submittal of Reports in Hard Copy Form

The following notifications and reports shall be submitted as hard copy with a cover letter describing the submission. These reports shall be signed and dated originals submitted to EPA.

- A. Written notifications required under Part II
- B. Reports and DMRs submitted prior to the use of NetDMR

This information shall be submitted to EPA/OES at the following address:

**U.S. Environmental Protection Agency  
Office of Environmental Stewardship (OES)  
Water Technical Unit  
5 Post Office Square, Suite 100 (OES 04-4)  
Boston, MA 02109-3912**

5. State Reporting

Unless otherwise specified in this permit, duplicate signed copies of all reports, information, requests or notifications described in this permit, including the reports, information, requests or notifications described in Parts I.D.3 and I.D.4 also shall be submitted to the State at the following addresses:

**MassDEP – Northeast Region  
Bureau of Waste Prevention  
205B Lowell Street  
Wilmington, MA 01887**

6. Submittal of NetDMR Opt-Out Requests

NetDMR opt-out requests must be submitted in writing to EPA for written approval at least sixty (60) days prior to the date a facility would be required under this permit to begin using NetDMR. This demonstration shall be valid for twelve (12) months from the date of EPA approval and shall thereupon expire. At such time, DMRs and reports shall be submitted electronically to EPA unless the permittee submits a renewed opt-out request and such request be approved by EPA. All opt-out requests should be sent to the following addresses:

**Attn: NetDMR Coordinator  
U.S. Environmental Protection Agency, Water Technical Unit  
5 Post Office Square, Suite 100 (OES 04-4)  
Boston, MA 02109-3912**

And

**Massachusetts Department of Environmental Protection  
Surface Water Discharge Permit Program  
1 Winter Street, 5<sup>th</sup> Floor  
Boston, Massachusetts 02108**

7. Verbal Reports and Verbal Notifications

Any verbal reports or verbal notifications, if required in Parts I and/or II of this permit, shall be made to both EPA-New England and to MassDEP. This includes verbal reports and notifications notification which require reporting within 24 hours. (As examples, see Part II.B.4.c. (2), Part II.B.5.c. (3), and Part II.D.1.e.) Verbal reports and verbal notifications shall be made to EPA's Office of Environmental Stewardship at:

**U.S. Environmental Protection Agency  
Office of Environmental Stewardship  
5 Post Office Square, Suite 100 (OES 04-4)  
Boston, MA 02109-3912  
617-918-1510**

**E. STATE PERMIT CONDITIONS**

1. This authorization to discharge includes two separate and independent permit authorizations. The two permit authorizations are (i) a federal National Pollutant Discharge Elimination System permit issued by the U.S. Environmental Protection Agency (EPA) pursuant to the Federal Clean Water Act, 33 U.S.C. §§1251 et seq.; and (ii) an identical state surface water discharge permit issued by the Commissioner of the Massachusetts Department of Environmental Protection (MassDEP) pursuant to the Massachusetts Clean Waters Act, M.G.L. c. 21, §§ 26-53, and 314 C.M.R. 3.00. All of the requirements contained in this authorization, as well as the standard conditions contained in 314 CMR 3.19, are hereby incorporated by reference into this state surface water discharge permit.
2. This authorization also incorporates the state water quality certification issued by MassDEP under § 401(a) of the Federal Clean Water Act, 40 C.F.R. 124.53, M.G.L. c. 21, § 27 and 314 CMR 3.07. All of the requirements (if any) contained in MassDEP's water quality certification for the permit are hereby incorporated by reference into this state surface water discharge permit as special conditions pursuant to 314 CMR 3.11.
3. Each Agency shall have the independent right to enforce the terms and conditions of this permit. Any modification, suspension or revocation of this permit shall be effective only with respect to the Agency taking such action, and shall not affect the validity or status of this permit as issued by the other Agency, unless and until each Agency has concurred in writing with such modification, suspension or revocation. In the event any portion of this permit is declared, invalid, illegal or otherwise issued in violation of State law such permit shall remain in full force and effect under Federal law as an NPDES permit issued by the U.S. Environmental Protection Agency. In the event this permit is declared invalid, illegal or otherwise issued in violation of Federal law, this permit shall remain in full force and effect under State law as a permit issued by the Commonwealth of Massachusetts.



NPDES PART II STANDARD CONDITIONS  
(January, 2007)

TABLE OF CONTENTS

A. GENERAL CONDITIONS	Page
1. <u>Duty to Comply</u>	2
2. <u>Permit Actions</u>	2
3. <u>Duty to Provide Information</u>	2
4. <u>Reopener Clause</u>	3
5. <u>Oil and Hazardous Substance Liability</u>	3
6. <u>Property Rights</u>	3
7. <u>Confidentiality of Information</u>	3
8. <u>Duty to Reapply</u>	4
9. <u>State Authorities</u>	4
10. <u>Other laws</u>	4
 B. OPERATION AND MAINTENANCE OF POLLUTION CONTROLS	
1. <u>Proper Operation and Maintenance</u>	4
2. <u>Need to Halt or Reduce Not a Defense</u>	4
3. <u>Duty to Mitigate</u>	4
4. <u>Bypass</u>	4
5. <u>Upset</u>	5
 C. MONITORING AND RECORDS	
1. <u>Monitoring and Records</u>	6
2. <u>Inspection and Entry</u>	7
 D. REPORTING REQUIREMENTS	
1. <u>Reporting Requirements</u>	7
a. Planned changes	7
b. Anticipated noncompliance	7
c. Transfers	7
d. Monitoring reports	8
e. Twenty-four hour reporting	8
f. Compliance schedules	9
g. Other noncompliance	9
h. Other information	9
2. <u>Signatory Requirement</u>	9
3. <u>Availability of Reports</u>	9
 E. DEFINITIONS AND ABBREVIATIONS	
1. <u>Definitions for Individual NPDES Permits including Storm Water Requirements</u>	9
2. <u>Definitions for NPDES Permit Sludge Use and Disposal Requirements</u>	17
3. <u>Commonly Used Abbreviations</u>	23

NPDES PART II STANDARD CONDITIONS  
(January, 2007)

PART II. A. GENERAL REQUIREMENTS

1. Duty to Comply

The permittee must comply with all conditions of this permit. Any permit noncompliance constitutes a violation of the Clean Water Act (CWA) and is grounds for enforcement action; for permit termination, revocation and reissuance, or modification; or for denial of a permit renewal application.

- a. The permittee shall comply with effluent standards or prohibitions established under Section 307(a) of the sludge use or disposal established under Section 405(d) of the CWA within the time provided in the regulations that establish these standards or prohibitions, even if the permit has not yet been modified to incorporate the requirements.
- b. The CWA provides that any person who violates Section 301, 302, 306, 307, 308, 318, or 405 of the CWA or any permit condition or limitation implementing any of such sections in a permit issued under Section 402, or any requirement imposed in a pretreatment program approved under Section 402 (a)(3) or 402 (b)(8) of the CWA is subject to a civil penalty not to exceed \$25,000 per day for each violation. Any person who negligently violates such requirements is subject to a fine of not less than \$2,500 nor more than \$25,000 per day of violation, or by imprisonment for not more than 1 year, or both. Any person who knowingly violates such requirements is subject to a fine of not less than \$5,000 nor more than \$50,000 per day of violation, or by imprisonment for not more than 3 years, or both.
- c. Any person may be assessed an administrative penalty by the Administrator for violating Section 301, 302, 306, 307, 308, 318, or 405 of the CWA, or any permit condition or limitation implementing any of such sections in a permit issued under Section 402 of the CWA. Administrative penalties for Class I violations are not to exceed \$10,000 per violation, with the maximum amount of any Class I penalty assessed not to exceed \$25,000. Penalties for Class II violations are not to exceed \$10,000 per day for each day during which the violation continues, with the maximum amount of any Class II penalty not to exceed \$125,000.

Note: See 40 CFR §122.41(a)(2) for complete “Duty to Comply” regulations.

2. Permit Actions

This permit may be modified, revoked and reissued, or terminated for cause. The filing of a request by the permittee for a permit modification, revocation and reissuance, or termination, or notifications of planned changes or anticipated noncompliance does not stay any permit condition.

3. Duty to Provide Information

The permittee shall furnish to the Regional Administrator, within a reasonable time, any information which the Regional Administrator may request to determine whether cause exists for modifying, revoking and reissuing, or terminating this permit, or to determine compliance with this permit. The permittee shall also furnish to the Regional Administrator, upon request, copies of records required to be kept by this permit.

NPDES PART II STANDARD CONDITIONS  
(January, 2007)

4. Reopener Clause

The Regional Administrator reserves the right to make appropriate revisions to this permit in order to establish any appropriate effluent limitations, schedules of compliance, or other provisions which may be authorized under the CWA in order to bring all discharges into compliance with the CWA.

For any permit issued to a treatment works treating domestic sewage (including “sludge-only facilities”), the Regional Administrator or Director shall include a reopener clause to incorporate any applicable standard for sewage sludge use or disposal promulgated under Section 405 (d) of the CWA. The Regional Administrator or Director may promptly modify or revoke and reissue any permit containing the reopener clause required by this paragraph if the standard for sewage sludge use or disposal is more stringent than any requirements for sludge use or disposal in the permit, or contains a pollutant or practice not limited in the permit.

Federal regulations pertaining to permit modification, revocation and reissuance, and termination are found at 40 CFR §122.62, 122.63, 122.64, and 124.5.

5. Oil and Hazardous Substance Liability

Nothing in this permit shall be construed to preclude the institution of any legal action or relieve the permittee from responsibilities, liabilities or penalties to which the permittee is or may be subject under Section 311 of the CWA, or Section 106 of the Comprehensive Environmental Response, Compensation and Liability Act of 1980 (CERCLA).

6. Property Rights

The issuance of this permit does not convey any property rights of any sort, nor any exclusive privileges.

7. Confidentiality of Information

- a. In accordance with 40 CFR Part 2, any information submitted to EPA pursuant to these regulations may be claimed as confidential by the submitter. Any such claim must be asserted at the time of submission in the manner prescribed on the application form or instructions or, in the case of other submissions, by stamping the words “confidential business information” on each page containing such information. If no claim is made at the time of submission, EPA may make the information available to the public without further notice. If a claim is asserted, the information will be treated in accordance with the procedures in 40 CFR Part 2 (Public Information).
- b. Claims of confidentiality for the following information will be denied:
  - (1) The name and address of any permit applicant or permittee;
  - (2) Permit applications, permits, and effluent data as defined in 40 CFR §2.302(a)(2).
- c. Information required by NPDES application forms provided by the Regional Administrator under 40 CFR §122.21 may not be claimed confidential. This includes information submitted on the forms themselves and any attachments used to supply information required by the forms.

NPDES PART II STANDARD CONDITIONS  
(January, 2007)

8. Duty to Reapply

If the permittee wishes to continue an activity regulated by this permit after its expiration date, the permittee must apply for and obtain a new permit. The permittee shall submit a new application at least 180 days before the expiration date of the existing permit, unless permission for a later date has been granted by the Regional Administrator. (The Regional Administrator shall not grant permission for applications to be submitted later than the expiration date of the existing permit.)

9. State Authorities

Nothing in Part 122, 123, or 124 precludes more stringent State regulation of any activity covered by these regulations, whether or not under an approved State program.

10. Other Laws

The issuance of a permit does not authorize any injury to persons or property or invasion of other private rights, nor does it relieve the permittee of its obligation to comply with any other applicable Federal, State, or local laws and regulations.

PART II. B. OPERATION AND MAINTENANCE OF POLLUTION CONTROLS

1. Proper Operation and Maintenance

The permittee shall at all times properly operate and maintain all facilities and systems of treatment and control (and related appurtenances) which are installed or used by the permittee to achieve compliance with the conditions of this permit and with the requirements of storm water pollution prevention plans. Proper operation and maintenance also includes adequate laboratory controls and appropriate quality assurance procedures. This provision requires the operation of back-up or auxiliary facilities or similar systems only when the operation is necessary to achieve compliance with the conditions of the permit.

2. Need to Halt or Reduce Not a Defense

It shall not be a defense for a permittee in an enforcement action that it would have been necessary to halt or reduce the permitted activity in order to maintain compliance with the conditions of this permit.

3. Duty to Mitigate

The permittee shall take all reasonable steps to minimize or prevent any discharge or sludge use or disposal in violation of this permit which has a reasonable likelihood of adversely affecting human health or the environment.

4. Bypass

a. Definitions

- (1) *Bypass* means the intentional diversion of waste streams from any portion of a treatment facility.

## NPDES PART II STANDARD CONDITIONS

(January, 2007)

- (2) *Severe property damage* means substantial physical damage to property, damage to the treatment facilities which causes them to become inoperable, or substantial and permanent loss of natural resources which can be reasonably expected to occur in the absence of a bypass. Severe property damage does not mean economic loss caused by delays in production.

### b. Bypass not exceeding limitations

The permittee may allow any bypass to occur which does not cause effluent limitations to be exceeded, but only if it also is for essential maintenance to assure efficient operation. These bypasses are not subject to the provision of Paragraphs B.4.c. and 4.d. of this section.

### c. Notice

- (1) Anticipated bypass. If the permittee knows in advance of the need for a bypass, it shall submit prior notice, if possible at least ten days before the date of the bypass.
- (2) Unanticipated bypass. The permittee shall submit notice of an unanticipated bypass as required in paragraph D.1.e. of this part (Twenty-four hour reporting).

### d. Prohibition of bypass

Bypass is prohibited, and the Regional Administrator may take enforcement action against a permittee for bypass, unless:

- (1) Bypass was unavoidable to prevent loss of life, personal injury, or severe property damage;
- (2) There were no feasible alternatives to the bypass, such as the use of auxiliary treatment facilities, retention of untreated wastes, or maintenance during normal periods of equipment downtime. This condition is not satisfied if adequate back-up equipment should have been installed in the exercise of reasonable engineering judgment to prevent a bypass which occurred during normal periods of equipment downtime or preventative maintenance; and
- (3) i) The permittee submitted notices as required under Paragraph 4.c. of this section.  
ii) The Regional Administrator may approve an anticipated bypass, after considering its adverse effects, if the Regional Administrator determines that it will meet the three conditions listed above in paragraph 4.d. of this section.

## 5. Upset

- a. Definition. *Upset* means an exceptional incident in which there is an unintentional and temporary noncompliance with technology-based permit effluent limitations because of factors beyond the reasonable control of the permittee. An upset does not include noncompliance to the extent caused by operational error, improperly designed treatment facilities, inadequate treatment facilities, lack of preventive maintenance, or careless or improper operation.
- b. Effect of an upset. An upset constitutes an affirmative defense to an action brought for noncompliance with such technology-based permit effluent limitations if the requirements of paragraph B.5.c. of this section are met. No determination made during

NPDES PART II STANDARD CONDITIONS  
(January, 2007)

administrative review of claims that noncompliance was caused by upset, and before an action for noncompliance, is final administrative action subject to judicial review.

- c. Conditions necessary for a demonstration of upset. A permittee who wishes to establish the affirmative defense of upset shall demonstrate, through properly signed, contemporaneous operating logs, or other relevant evidence that:
  - (1) An upset occurred and that the permittee can identify the cause(s) of the upset;
  - (2) The permitted facility was at the time being properly operated;
  - (3) The permittee submitted notice of the upset as required in paragraphs D.1.a. and 1.e. (Twenty-four hour notice); and
  - (4) The permittee complied with any remedial measures required under B.3. above.
- d. Burden of proof. In any enforcement proceeding the permittee seeking to establish the occurrence of an upset has the burden of proof.

PART II. C. MONITORING REQUIREMENTS

1. Monitoring and Records

- a. Samples and measurements taken for the purpose of monitoring shall be representative of the monitored activity.
- b. Except for records for monitoring information required by this permit related to the permittee's sewage sludge use and disposal activities, which shall be retained for a period of at least five years (or longer as required by 40 CFR Part 503), the permittee shall retain records of all monitoring information, including all calibration and maintenance records and all original strip chart recordings for continuous monitoring instrumentation, copies of all reports required by this permit, and records of all data used to complete the application for this permit, for a period of at least 3 years from the date of the sample, measurement, report or application except for the information concerning storm water discharges which must be retained for a total of 6 years. This retention period may be extended by request of the Regional Administrator at any time.
- c. Records of monitoring information shall include:
  - (1) The date, exact place, and time of sampling or measurements;
  - (2) The individual(s) who performed the sampling or measurements;
  - (3) The date(s) analyses were performed;
  - (4) The individual(s) who performed the analyses;
  - (5) The analytical techniques or methods used; and
  - (6) The results of such analyses.
- d. Monitoring results must be conducted according to test procedures approved under 40 CFR Part 136 or, in the case of sludge use or disposal, approved under 40 CFR Part 136 unless otherwise specified in 40 CFR Part 503, unless other test procedures have been specified in the permit.
- e. The CWA provides that any person who falsifies, tampers with, or knowingly renders inaccurate any monitoring device or method required to be maintained under this permit shall, upon conviction, be punished by a fine of not more than \$10,000, or by

## NPDES PART II STANDARD CONDITIONS

(January, 2007)

imprisonment for not more than 2 years, or both. If a conviction of a person is for a violation committed after a first conviction of such person under this paragraph, punishment is a fine of not more than \$20,000 per day of violation, or by imprisonment of not more than 4 years, or both.

### 2. Inspection and Entry

The permittee shall allow the Regional Administrator or an authorized representative (including an authorized contractor acting as a representative of the Administrator), upon presentation of credentials and other documents as may be required by law, to:

- a. Enter upon the permittee's premises where a regulated facility or activity is located or conducted, or where records must be kept under the conditions of this permit;
- b. Have access to and copy, at reasonable times, any records that must be kept under the conditions of this permit;
- c. Inspect at reasonable times any facilities, equipment (including monitoring and control equipment), practices, or operations regulated or required under this permit; and
- d. Sample or monitor at reasonable times, for the purposes of assuring permit compliance or as otherwise authorized by the CWA, any substances or parameters at any location.

## PART II. D. REPORTING REQUIREMENTS

### 1. Reporting Requirements

- a. **Planned Changes.** The permittee shall give notice to the Regional Administrator as soon as possible of any planned physical alterations or additions to the permitted facility. Notice is only required when:
  - (1) The alteration or addition to a permitted facility may meet one of the criteria for determining whether a facility is a new source in 40 CFR§122.29(b); or
  - (2) The alteration or addition could significantly change the nature or increase the quantities of the pollutants discharged. This notification applies to pollutants which are subject neither to the effluent limitations in the permit, nor to the notification requirements at 40 CFR§122.42(a)(1).
  - (3) The alteration or addition results in a significant change in the permittee's sludge use or disposal practices, and such alteration, addition or change may justify the application of permit conditions different from or absent in the existing permit, including notification of additional use or disposal sites not reported during the permit application process or not reported pursuant to an approved land application plan.
- b. **Anticipated noncompliance.** The permittee shall give advance notice to the Regional Administrator of any planned changes in the permitted facility or activity which may result in noncompliance with permit requirements.
- c. **Transfers.** This permit is not transferable to any person except after notice to the Regional Administrator. The Regional Administrator may require modification or revocation and reissuance of the permit to change the name of the permittee and

## NPDES PART II STANDARD CONDITIONS

(January, 2007)

incorporate such other requirements as may be necessary under the CWA. (See 40 CFR Part 122.61; in some cases, modification or revocation and reissuance is mandatory.)

- d. Monitoring reports. Monitoring results shall be reported at the intervals specified elsewhere in this permit.
- (1) Monitoring results must be reported on a Discharge Monitoring Report (DMR) or forms provided or specified by the Director for reporting results of monitoring of sludge use or disposal practices.
  - (2) If the permittee monitors any pollutant more frequently than required by the permit using test procedures approved under 40 CFR Part 136 or, in the case of sludge use or disposal, approved under 40 CFR Part 136 unless otherwise specified in 40 CFR Part 503, or as specified in the permit, the results of the monitoring shall be included in the calculation and reporting of the data submitted in the DMR or sludge reporting form specified by the Director.
  - (3) Calculations for all limitations which require averaging or measurements shall utilize an arithmetic mean unless otherwise specified by the Director in the permit.
- e. Twenty-four hour reporting.
- (1) The permittee shall report any noncompliance which may endanger health or the environment. Any information shall be provided orally within 24 hours from the time the permittee becomes aware of the circumstances.  
  
A written submission shall also be provided within 5 days of the time the permittee becomes aware of the circumstances. The written submission shall contain a description of the noncompliance and its cause; the period of noncompliance, including exact dates and times, and if the noncompliance has not been corrected, the anticipated time it is expected to continue; and steps taken or planned to reduce, eliminate, and prevent reoccurrence of the noncompliance.
  - (2) The following shall be included as information which must be reported within 24 hours under this paragraph.
    - (a) Any unanticipated bypass which exceeds any effluent limitation in the permit. (See 40 CFR §122.41(g).)
    - (b) Any upset which exceeds any effluent limitation in the permit.
    - (c) Violation of a maximum daily discharge limitation for any of the pollutants listed by the Regional Administrator in the permit to be reported within 24 hours. (See 40 CFR §122.44(g).)
  - (3) The Regional Administrator may waive the written report on a case-by-case basis for reports under Paragraph D.1.e. if the oral report has been received within 24 hours.



NPDES PART II STANDARD CONDITIONS  
(January, 2007)

- f. Compliance Schedules. Reports of compliance or noncompliance with, any progress reports on, interim and final requirements contained in any compliance schedule of this permit shall be submitted no later than 14 days following each schedule date.
  - g. Other noncompliance. The permittee shall report all instances of noncompliance not reported under Paragraphs D.1.d., D.1.e., and D.1.f. of this section, at the time monitoring reports are submitted. The reports shall contain the information listed in Paragraph D.1.e. of this section.
  - h. Other information. Where the permittee becomes aware that it failed to submit any relevant facts in a permit application, or submitted incorrect information in a permit application or in any report to the Regional Administrator, it shall promptly submit such facts or information.
2. Signatory Requirement
- a. All applications, reports, or information submitted to the Regional Administrator shall be signed and certified. (See 40 CFR §122.22)
  - b. The CWA provides that any person who knowingly makes any false statement, representation, or certification in any record or other document submitted or required to be maintained under this permit, including monitoring reports or reports of compliance or noncompliance shall, upon conviction, be punished by a fine of not more than \$10,000 per violation, or by imprisonment for not more than 2 years per violation, or by both.
3. Availability of Reports.

Except for data determined to be confidential under Paragraph A.8. above, all reports prepared in accordance with the terms of this permit shall be available for public inspection at the offices of the State water pollution control agency and the Regional Administrator. As required by the CWA, effluent data shall not be considered confidential. Knowingly making any false statements on any such report may result in the imposition of criminal penalties as provided for in Section 309 of the CWA.

PART II. E. DEFINITIONS AND ABBREVIATIONS

1. Definitions for Individual NPDES Permits including Storm Water Requirements

*Administrator* means the Administrator of the United States Environmental Protection Agency, or an authorized representative.

*Applicable standards and limitations* means all, State, interstate, and Federal standards and limitations to which a “discharge”, a “sewage sludge use or disposal practice”, or a related activity is subject to, including “effluent limitations”, water quality standards, standards of performance, toxic effluent standards or prohibitions, “best management practices”, pretreatment standards, and “standards for sewage sludge use and disposal” under Sections 301, 302, 303, 304, 306, 307, 308, 403, and 405 of the CWA.

NPDES PART II STANDARD CONDITIONS  
(January, 2007)

*Application* means the EPA standard national forms for applying for a permit, including any additions, revisions, or modifications to the forms; or forms approved by EPA for use in “approved States”, including any approved modifications or revisions.

*Average* means the arithmetic mean of values taken at the frequency required for each parameter over the specified period. For total and/or fecal coliforms and Escherichia coli, the average shall be the geometric mean.

*Average monthly discharge limitation* means the highest allowable average of “daily discharges” over a calendar month calculated as the sum of all “daily discharges” measured during a calendar month divided by the number of “daily discharges” measured during that month.

*Average weekly discharge limitation* means the highest allowable average of “daily discharges” measured during the calendar week divided by the number of “daily discharges” measured during the week.

*Best Management Practices (BMPs)* means schedules of activities, prohibitions of practices, maintenance procedures, and other management practices to prevent or reduce the pollution of “waters of the United States.” BMPs also include treatment requirements, operating procedures, and practices to control plant site runoff, spillage or leaks, sludge or waste disposal, or drainage from raw material storage.

*Best Professional Judgment (BPJ)* means a case-by-case determination of Best Practicable Treatment (BPT), Best Available Treatment (BAT), or other appropriate technology-based standard based on an evaluation of the available technology to achieve a particular pollutant reduction and other factors set forth in 40 CFR §125.3 (d).

*Coal Pile Runoff* means the rainfall runoff from or through any coal storage pile.

*Composite Sample* means a sample consisting of a minimum of eight grab samples of equal volume collected at equal intervals during a 24-hour period (or lesser period as specified in the section on Monitoring and Reporting) and combined proportional to flow, or a sample consisting of the same number of grab samples, or greater, collected proportionally to flow over that same time period.

*Construction Activities* - The following definitions apply to construction activities:

- (a) Commencement of Construction is the initial disturbance of soils associated with clearing, grading, or excavating activities or other construction activities.
- (b) Dedicated portable asphalt plant is a portable asphalt plant located on or contiguous to a construction site and that provides asphalt only to the construction site that the plant is located on or adjacent to. The term dedicated portable asphalt plant does not include facilities that are subject to the asphalt emulsion effluent limitation guideline at 40 CFR Part 443.
- (c) Dedicated portable concrete plant is a portable concrete plant located on or contiguous to a construction site and that provides concrete only to the construction site that the plant is located on or adjacent to.

## NPDES PART II STANDARD CONDITIONS

(January, 2007)

- (d) Final Stabilization means that all soil disturbing activities at the site have been complete, and that a uniform perennial vegetative cover with a density of 70% of the cover for unpaved areas and areas not covered by permanent structures has been established or equivalent permanent stabilization measures (such as the use of riprap, gabions, or geotextiles) have been employed.
- (e) Runoff coefficient means the fraction of total rainfall that will appear at the conveyance as runoff.

*Contiguous zone* means the entire zone established by the United States under Article 24 of the Convention on the Territorial Sea and the Contiguous Zone.

*Continuous discharge* means a “discharge” which occurs without interruption throughout the operating hours of the facility except for infrequent shutdowns for maintenance, process changes, or similar activities.

CWA means the Clean Water Act (formerly referred to as the Federal Water Pollution Control Act or Federal Water Pollution Control Act Amendments of 1972) Pub. L. 92-500, as amended by Pub. L. 95-217, Pub. L. 95-576, Pub. L. 96-483, and Pub. L. 97-117; 33 USC §§1251 et seq.

*Daily Discharge* means the discharge of a pollutant measured during the calendar day or any other 24-hour period that reasonably represents the calendar day for purposes of sampling. For pollutants with limitations expressed in units of mass, the “daily discharge” is calculated as the total mass of the pollutant discharged over the day. For pollutants with limitations expressed in other units of measurements, the “daily discharge” is calculated as the average measurement of the pollutant over the day.

*Director* normally means the person authorized to sign NPDES permits by EPA or the State or an authorized representative. Conversely, it also could mean the Regional Administrator or the State Director as the context requires.

*Discharge Monitoring Report Form (DMR)* means the EPA standard national form, including any subsequent additions, revisions, or modifications for the reporting of self-monitoring results by permittees. DMRs must be used by “approved States” as well as by EPA. EPA will supply DMRs to any approved State upon request. The EPA national forms may be modified to substitute the State Agency name, address, logo, and other similar information, as appropriate, in place of EPA’s.

*Discharge of a pollutant* means:

- (a) Any addition of any “pollutant” or combination of pollutants to “waters of the United States” from any “point source”, or
- (b) Any addition of any pollutant or combination of pollutants to the waters of the “contiguous zone” or the ocean from any point source other than a vessel or other floating craft which is being used as a means of transportation (See “Point Source” definition).

This definition includes additions of pollutants into waters of the United States from: surface runoff which is collected or channeled by man; discharges through pipes, sewers, or other conveyances owned by a State, municipality, or other person which do not lead

NPDES PART II STANDARD CONDITIONS  
(January, 2007)

to a treatment works; and discharges through pipes, sewers, or other conveyances leading into privately owned treatment works.

This term does not include an addition of pollutants by any “indirect discharger.”

*Effluent limitation* means any restriction imposed by the Regional Administrator on quantities, discharge rates, and concentrations of “pollutants” which are “discharged” from “point sources” into “waters of the United States”, the waters of the “contiguous zone”, or the ocean.

*Effluent limitation guidelines* means a regulation published by the Administrator under Section 304(b) of CWA to adopt or revise “effluent limitations”.

*EPA* means the United States “Environmental Protection Agency”.

*Flow-weighted composite sample* means a composite sample consisting of a mixture of aliquots where the volume of each aliquot is proportional to the flow rate of the discharge.

*Grab Sample* – An individual sample collected in a period of less than 15 minutes.

*Hazardous Substance* means any substance designated under 40 CFR Part 116 pursuant to Section 311 of the CWA.

*Indirect Discharger* means a non-domestic discharger introducing pollutants to a publicly owned treatment works.

*Interference* means a discharge which, alone or in conjunction with a discharge or discharges from other sources, both:

- (a) Inhibits or disrupts the POTW, its treatment processes or operations, or its sludge processes, use or disposal; and
- (b) Therefore is a cause of a violation of any requirement of the POTW’s NPDES permit (including an increase in the magnitude or duration of a violation) or of the prevention of sewage sludge use or disposal in compliance with the following statutory provisions and regulations or permits issued thereunder (or more stringent State or local regulations): Section 405 of the Clean Water Act (CWA), the Solid Waste Disposal Act (SWDA) (including Title II, more commonly referred to as the Resources Conservation and Recovery Act (RCRA), and including State regulations contained in any State sludge management plan prepared pursuant to Subtitle D of the SDWA), the Clean Air Act, the Toxic Substances Control Act, and the Marine Protection Research and Sanctuaries Act.

*Landfill* means an area of land or an excavation in which wastes are placed for permanent disposal, and which is not a land application unit, surface impoundment, injection well, or waste pile.

*Land application unit* means an area where wastes are applied onto or incorporated into the soil surface (excluding manure spreading operations) for treatment or disposal.

*Large and Medium municipal separate storm sewer system* means all municipal separate storm sewers that are either: (i) located in an incorporated place (city) with a population of 100,000 or more as determined by the latest Decennial Census by the Bureau of Census (these cities are listed in Appendices F and 40 CFR Part 122); or (ii) located in the counties with unincorporated urbanized

## NPDES PART II STANDARD CONDITIONS

(January, 2007)

populations of 100,000 or more, except municipal separate storm sewers that are located in the incorporated places, townships, or towns within such counties (these counties are listed in Appendices H and I of 40 CFR 122); or (iii) owned or operated by a municipality other than those described in Paragraph (i) or (ii) and that are designated by the Regional Administrator as part of the large or medium municipal separate storm sewer system.

*Maximum daily discharge limitation* means the highest allowable “daily discharge” concentration that occurs only during a normal day (24-hour duration).

*Maximum daily discharge limitation (as defined for the Steam Electric Power Plants only) when applied to Total Residual Chlorine (TRC) or Total Residual Oxidant (TRO)* is defined as “maximum concentration” or “Instantaneous Maximum Concentration” during the two hours of a chlorination cycle (or fraction thereof) prescribed in the Steam Electric Guidelines, 40 CFR Part 423. These three synonymous terms all mean “a value that shall not be exceeded” during the two-hour chlorination cycle. This interpretation differs from the specified NPDES Permit requirement, 40 CFR § 122.2, where the two terms of “Maximum Daily Discharge” and “Average Daily Discharge” concentrations are specifically limited to the daily (24-hour duration) values.

*Municipality* means a city, town, borough, county, parish, district, association, or other public body created by or under State law and having jurisdiction over disposal of sewage, industrial wastes, or other wastes, or an Indian tribe or an authorized Indian tribe organization, or a designated and approved management agency under Section 208 of the CWA.

*National Pollutant Discharge Elimination System* means the national program for issuing, modifying, revoking and reissuing, terminating, monitoring and enforcing permits, and imposing and enforcing pretreatment requirements, under Sections 307, 402, 318, and 405 of the CWA. The term includes an “approved program”.

*New Discharger* means any building, structure, facility, or installation:

- (a) From which there is or may be a “discharge of pollutants”;
- (b) That did not commence the “discharge of pollutants” at a particular “site” prior to August 13, 1979;
- (c) Which is not a “new source”; and
- (d) Which has never received a finally effective NPDES permit for discharges at that “site”.

This definition includes an “indirect discharger” which commences discharging into “waters of the United States” after August 13, 1979. It also includes any existing mobile point source (other than an offshore or coastal oil and gas exploratory drilling rig or a coastal oil and gas exploratory drilling rig or a coastal oil and gas developmental drilling rig) such as a seafood processing rig, seafood processing vessel, or aggregate plant, that begins discharging at a “site” for which it does not have a permit; and any offshore rig or coastal mobile oil and gas exploratory drilling rig or coastal mobile oil and gas developmental drilling rig that commences the discharge of pollutants after August 13, 1979, at a “site” under EPA’s permitting jurisdiction for which it is not covered by an individual or general permit and which is located in an area determined by the Regional Administrator in the issuance of a final permit to be in an area of biological concern. In determining whether an area is an area of biological concern, the Regional Administrator shall consider the factors specified in 40 CFR §§125.122 (a) (1) through (10).

NPDES PART II STANDARD CONDITIONS  
(January, 2007)

An offshore or coastal mobile exploratory drilling rig or coastal mobile developmental drilling rig will be considered a “new discharger” only for the duration of its discharge in an area of biological concern.

*New source* means any building, structure, facility, or installation from which there is or may be a “discharge of pollutants”, the construction of which commenced:

- (a) After promulgation of standards of performance under Section 306 of CWA which are applicable to such source, or
- (b) After proposal of standards of performance in accordance with Section 306 of CWA which are applicable to such source, but only if the standards are promulgated in accordance with Section 306 within 120 days of their proposal.

*NPDES* means “National Pollutant Discharge Elimination System”.

*Owner or operator* means the owner or operator of any “facility or activity” subject to regulation under the NPDES programs.

*Pass through* means a Discharge which exits the POTW into waters of the United States in quantities or concentrations which, alone or in conjunction with a discharge or discharges from other sources, is a cause of a violation of any requirement of the POTW’s NPDES permit (including an increase in the magnitude or duration of a violation).

*Permit* means an authorization, license, or equivalent control document issued by EPA or an “approved” State.

*Person* means an individual, association, partnership, corporation, municipality, State or Federal agency, or an agent or employee thereof.

*Point Source* means any discernible, confined, and discrete conveyance, including but not limited to any pipe ditch, channel, tunnel, conduit, well, discrete fissure, container, rolling stock, concentrated animal feeding operation, landfill leachate collection system, vessel, or other floating craft, from which pollutants are or may be discharged. This term does not include return flows from irrigated agriculture or agricultural storm water runoff (see 40 CFR §122.2).

*Pollutant* means dredged spoil, solid waste, incinerator residue, filter backwash, sewage, garbage, sewage sludge, munitions, chemical wastes, biological materials, radioactive materials (except those regulated under the Atomic Energy Act of 1954, as amended (42 U.S.C. §§2011 et seq.)), heat, wrecked or discarded equipment, rock, sand, cellar dirt and industrial, municipal, and agricultural waste discharged into water. It does not mean:

- (a) Sewage from vessels; or
- (b) Water, gas, or other material which is injected into a well to facilitate production of oil or gas, or water derived in association with oil and gas production and disposed of in a well, if the well is used either to facilitate production or for disposal purposes is approved by the authority of the State in which the well is located, and if the State determines that the injection or disposal will not result in the degradation of ground or surface water resources.

NPDES PART II STANDARD CONDITIONS  
(January, 2007)

*Primary industry category* means any industry category listed in the NRDC settlement agreement (Natural Resources Defense Council et al. v. Train, 8 E.R.C. 2120 (D.D.C. 1976), modified 12 E.R.C. 1833 (D. D.C. 1979)); also listed in Appendix A of 40 CFR Part 122.

*Privately owned treatment works* means any device or system which is (a) used to treat wastes from any facility whose operation is not the operator of the treatment works or (b) not a “POTW”.

*Process wastewater* means any water which, during manufacturing or processing, comes into direct contact with or results from the production or use of any raw material, intermediate product, finished product, byproduct, or waste product.

*Publicly Owned Treatment Works (POTW)* means any facility or system used in the treatment (including recycling and reclamation) of municipal sewage or industrial wastes of a liquid nature which is owned by a “State” or “municipality”.

This definition includes sewers, pipes, or other conveyances only if they convey wastewater to a POTW providing treatment.

*Regional Administrator* means the Regional Administrator, EPA, Region I, Boston, Massachusetts.

*Secondary Industry Category* means any industry which is not a “primary industry category”.

*Section 313 water priority chemical* means a chemical or chemical category which:

- (1) is listed at 40 CFR §372.65 pursuant to Section 313 of the Emergency Planning and Community Right-To-Know Act (EPCRA) (also known as Title III of the Superfund Amendments and Reauthorization Act (SARA) of 1986);
- (2) is present at or above threshold levels at a facility subject to EPCRA Section 313 reporting requirements; and
- (3) satisfies at least one of the following criteria:
  - (i) are listed in Appendix D of 40 CFR Part 122 on either Table II (organic priority pollutants), Table III (certain metals, cyanides, and phenols), or Table V (certain toxic pollutants and hazardous substances);
  - (ii) are listed as a hazardous substance pursuant to Section 311(b)(2)(A) of the CWA at 40 CFR §116.4; or
  - (iii) are pollutants for which EPA has published acute or chronic water quality criteria.

*Septage* means the liquid and solid material pumped from a septic tank, cesspool, or similar domestic sewage treatment system, or a holding tank when the system is cleaned or maintained.

*Sewage Sludge* means any solid, semisolid, or liquid residue removed during the treatment of municipal wastewater or domestic sewage. Sewage sludge includes, but is not limited to, solids removed during primary, secondary, or advanced wastewater treatment, scum, septage, portable toilet pumpings, Type III Marine Sanitation Device pumpings (33 CFR Part 159), and sewage sludge products. Sewage sludge does not include grit or screenings, or ash generated during the incineration of sewage sludge.

NPDES PART II STANDARD CONDITIONS  
(January, 2007)

*Sewage sludge use or disposal practice* means the collection, storage, treatment, transportation, processing, monitoring, use, or disposal of sewage sludge.

*Significant materials* includes, but is not limited to: raw materials, fuels, materials such as solvents, detergents, and plastic pellets, raw materials used in food processing or production, hazardous substance designated under section 101(14) of CERCLA, any chemical the facility is required to report pursuant to EPCRA Section 313, fertilizers, pesticides, and waste products such as ashes, slag, and sludge that have the potential to be released with storm water discharges.

*Significant spills* includes, but is not limited to, releases of oil or hazardous substances in excess of reportable quantities under Section 311 of the CWA (see 40 CFR §110.10 and §117.21) or Section 102 of CERCLA (see 40 CFR § 302.4).

*Sludge-only facility* means any “treatment works treating domestic sewage” whose methods of sewage sludge use or disposal are subject to regulations promulgated pursuant to Section 405(d) of the CWA, and is required to obtain a permit under 40 CFR §122.1(b)(3).

*State* means any of the 50 States, the District of Columbia, Guam, the Commonwealth of Puerto Rico, the Virgin Islands, American Samoa, the Trust Territory of the Pacific Islands.

*Storm Water* means storm water runoff, snow melt runoff, and surface runoff and drainage.

*Storm water discharge associated with industrial activity* means the discharge from any conveyance which is used for collecting and conveying storm water and which is directly related to manufacturing, processing, or raw materials storage areas at an industrial plant. (See 40 CFR §122.26 (b)(14) for specifics of this definition.

*Time-weighted composite* means a composite sample consisting of a mixture of equal volume aliquots collected at a constant time interval.

*Toxic pollutants* means any pollutant listed as toxic under Section 307 (a)(1) or, in the case of “sludge use or disposal practices” any pollutant identified in regulations implementing Section 405(d) of the CWA.

*Treatment works treating domestic sewage* means a POTW or any other sewage sludge or wastewater treatment devices or systems, regardless of ownership (including federal facilities), used in the storage, treatment, recycling, and reclamation of municipal or domestic sewage, including land dedicated for the disposal of sewage sludge. This definition does not include septic tanks or similar devices.

For purposes of this definition, “domestic sewage” includes waste and wastewater from humans or household operations that are discharged to or otherwise enter a treatment works. In States where there is no approved State sludge management program under Section 405(f) of the CWA, the Regional Administrator may designate any person subject to the standards for sewage sludge use and disposal in 40 CFR Part 503 as a “treatment works treating domestic sewage”, where he or she finds that there is a potential for adverse effects on public health and the environment from poor sludge quality or poor sludge handling, use or disposal practices, or where he or she finds that such designation is necessary to ensure that such person is in compliance with 40 CFR Part 503.



NPDES PART II STANDARD CONDITIONS  
(January, 2007)

*Waste Pile* means any non-containerized accumulation of solid, non-flowing waste that is used for treatment or storage.

*Waters of the United States* means:

- (a) All waters which are currently used, were used in the past, or may be susceptible to use in interstate or foreign commerce, including all waters which are subject to the ebb and flow of tide;
- (b) All interstate waters, including interstate “wetlands”;
- (c) All other waters such as intrastate lakes, rivers, streams (including intermittent streams), mudflats, sandflats, “wetlands”, sloughs, prairie potholes, wet meadows, playa lakes, or natural ponds the use, degradation, or destruction of which would affect or could affect interstate or foreign commerce including any such waters:
  - (1) Which are or could be used by interstate or foreign travelers for recreational or other purpose;
  - (2) From which fish or shellfish are or could be taken and sold in interstate or foreign commerce; or
  - (3) Which are used or could be used for industrial purposes by industries in interstate commerce;
- (d) All impoundments of waters otherwise defined as waters of the United States under this definition;
- (e) Tributaries of waters identified in Paragraphs (a) through (d) of this definition;
- (f) The territorial sea; and
- (g) “Wetlands” adjacent to waters (other than waters that are themselves wetlands) identified in Paragraphs (a) through (f) of this definition.

Waste treatment systems, including treatment ponds or lagoons designed to meet the requirements of the CWA (other than cooling ponds as defined in 40 CFR §423.11(m) which also meet the criteria of this definition) are not waters of the United States.

*Wetlands* means those areas that are inundated or saturated by surface or ground water at a frequency and duration to support, and that under normal circumstances do support, a prevalence of vegetation typically adapted for life in saturated soil conditions. Wetlands generally include swamps, marshes, bogs, and similar areas.

*Whole Effluent Toxicity (WET)* means the aggregate toxic effect of an effluent measured directly by a toxicity test. (See Abbreviations Section, following, for additional information.)

2. Definitions for NPDES Permit Sludge Use and Disposal Requirements.

*Active sewage sludge unit* is a sewage sludge unit that has not closed.

## NPDES PART II STANDARD CONDITIONS

(January, 2007)

*Aerobic Digestion* is the biochemical decomposition of organic matter in sewage sludge into carbon dioxide and water by microorganisms in the presence of air.

*Agricultural Land* is land on which a food crop, a feed crop, or a fiber crop is grown. This includes range land and land used as pasture.

*Agronomic rate* is the whole sludge application rate (dry weight basis) designed:

- (1) To provide the amount of nitrogen needed by the food crop, feed crop, fiber crop, cover crop, or vegetation grown on the land; and
- (2) To minimize the amount of nitrogen in the sewage sludge that passes below the root zone of the crop or vegetation grown on the land to the ground water.

*Air pollution control device* is one or more processes used to treat the exit gas from a sewage sludge incinerator stack.

*Anaerobic digestion* is the biochemical decomposition of organic matter in sewage sludge into methane gas and carbon dioxide by microorganisms in the absence of air.

*Annual pollutant loading rate* is the maximum amount of a pollutant that can be applied to a unit area of land during a 365 day period.

*Annual whole sludge application rate* is the maximum amount of sewage sludge (dry weight basis) that can be applied to a unit area of land during a 365 day period.

*Apply sewage sludge or sewage sludge applied to the land* means land application of sewage sludge.

*Aquifer* is a geologic formation, group of geologic formations, or a portion of a geologic formation capable of yielding ground water to wells or springs.

*Auxiliary fuel* is fuel used to augment the fuel value of sewage sludge. This includes, but is not limited to, natural gas, fuel oil, coal, gas generated during anaerobic digestion of sewage sludge, and municipal solid waste (not to exceed 30 percent of the dry weight of the sewage sludge and auxiliary fuel together). Hazardous wastes are not auxiliary fuel.

*Base flood* is a flood that has a one percent chance of occurring in any given year (i.e. a flood with a magnitude equaled once in 100 years).

*Bulk sewage sludge* is sewage sludge that is not sold or given away in a bag or other container for application to the land.

*Contaminate an aquifer* means to introduce a substance that causes the maximum contaminant level for nitrate in 40 CFR §141.11 to be exceeded in ground water or that causes the existing concentration of nitrate in the ground water to increase when the existing concentration of nitrate in the ground water exceeds the maximum contaminant level for nitrate in 40 CFR §141.11.

*Class I sludge management facility* is any publicly owned treatment works (POTW), as defined in 40 CFR §501.2, required to have an approved pretreatment program under 40 CFR §403.8 (a) (including any POTW located in a state that has elected to assume local program responsibilities pursuant to 40 CFR §403.10 (e) and any treatment works treating domestic sewage, as defined in 40 CFR § 122.2,

## NPDES PART II STANDARD CONDITIONS

(January, 2007)

classified as a Class I sludge management facility by the EPA Regional Administrator, or, in the case of approved state programs, the Regional Administrator in conjunction with the State Director, because of the potential for sewage sludge use or disposal practice to affect public health and the environment adversely.

*Control efficiency* is the mass of a pollutant in the sewage sludge fed to an incinerator minus the mass of that pollutant in the exit gas from the incinerator stack divided by the mass of the pollutant in the sewage sludge fed to the incinerator.

*Cover* is soil or other material used to cover sewage sludge placed on an active sewage sludge unit.

*Cover crop* is a small grain crop, such as oats, wheat, or barley, not grown for harvest.

*Cumulative pollutant loading rate* is the maximum amount of inorganic pollutant that can be applied to an area of land.

*Density of microorganisms* is the number of microorganisms per unit mass of total solids (dry weight) in the sewage sludge.

*Dispersion factor* is the ratio of the increase in the ground level ambient air concentration for a pollutant at or beyond the property line of the site where the sewage sludge incinerator is located to the mass emission rate for the pollutant from the incinerator stack.

*Displacement* is the relative movement of any two sides of a fault measured in any direction.

*Domestic septage* is either liquid or solid material removed from a septic tank, cesspool, portable toilet, Type III marine sanitation device, or similar treatment works that receives only domestic sewage. Domestic septage does not include liquid or solid material removed from a septic tank, cesspool, or similar treatment works that receives either commercial wastewater or industrial wastewater and does not include grease removed from a grease trap at a restaurant.

*Domestic sewage* is waste and wastewater from humans or household operations that is discharged to or otherwise enters a treatment works.

*Dry weight basis* means calculated on the basis of having been dried at 105 degrees Celsius (°C) until reaching a constant mass (i.e. essentially 100 percent solids content).

*Fault* is a fracture or zone of fractures in any materials along which strata on one side are displaced with respect to the strata on the other side.

*Feed crops* are crops produced primarily for consumption by animals.

*Fiber crops* are crops such as flax and cotton.

*Final cover* is the last layer of soil or other material placed on a sewage sludge unit at closure.

*Fluidized bed incinerator* is an enclosed device in which organic matter and inorganic matter in sewage sludge are combusted in a bed of particles suspended in the combustion chamber gas.

*Food crops* are crops consumed by humans. These include, but are not limited to, fruits, vegetables, and tobacco.

NPDES PART II STANDARD CONDITIONS  
(January, 2007)

*Forest* is a tract of land thick with trees and underbrush.

*Ground water* is water below the land surface in the saturated zone.

*Holocene time* is the most recent epoch of the Quaternary period, extending from the end of the Pleistocene epoch to the present.

*Hourly average* is the arithmetic mean of all the measurements taken during an hour. At least two measurements must be taken during the hour.

*Incineration* is the combustion of organic matter and inorganic matter in sewage sludge by high temperatures in an enclosed device.

*Industrial wastewater* is wastewater generated in a commercial or industrial process.

*Land application* is the spraying or spreading of sewage sludge onto the land surface; the injection of sewage sludge below the land surface; or the incorporation of sewage sludge into the soil so that the sewage sludge can either condition the soil or fertilize crops or vegetation grown in the soil.

*Land with a high potential for public exposure* is land that the public uses frequently. This includes, but is not limited to, a public contact site and reclamation site located in a populated area (e.g., a construction site located in a city).

*Land with low potential for public exposure* is land that the public uses infrequently. This includes, but is not limited to, agricultural land, forest and a reclamation site located in an unpopulated area (e.g., a strip mine located in a rural area).

*Leachate collection system* is a system or device installed immediately above a liner that is designed, constructed, maintained, and operated to collect and remove leachate from a sewage sludge unit.

*Liner* is soil or synthetic material that has a hydraulic conductivity of  $1 \times 10^{-7}$  centimeters per second or less.

*Lower explosive limit for methane gas* is the lowest percentage of methane gas in air, by volume, that propagates a flame at 25 degrees Celsius and atmospheric pressure.

*Monthly average (Incineration)* is the arithmetic mean of the hourly averages for the hours a sewage sludge incinerator operates during the month.

*Monthly average (Land Application)* is the arithmetic mean of all measurements taken during the month.

*Municipality* means a city, town, borough, county, parish, district, association, or other public body (including an intermunicipal agency of two or more of the foregoing entities) created by or under State law; an Indian tribe or an authorized Indian tribal organization having jurisdiction over sewage sludge management; or a designated and approved management agency under section 208 of the CWA, as amended. The definition includes a special district created under state law, such as a water district, sewer district, sanitary district, utility district, drainage district, or similar entity, or an integrated waste management facility as defined in section 201 (e) of the CWA, as amended, that has as one of its principal responsibilities the treatment, transport, use or disposal of sewage sludge.

NPDES PART II STANDARD CONDITIONS  
(January, 2007)

*Other container* is either an open or closed receptacle. This includes, but is not limited to, a bucket, a box, a carton, and a vehicle or trailer with a load capacity of one metric ton or less.

*Pasture* is land on which animals feed directly on feed crops such as legumes, grasses, grain stubble, or stover.

*Pathogenic organisms* are disease-causing organisms. These include, but are not limited to, certain bacteria, protozoa, viruses, and viable helminth ova.

*Permitting authority* is either EPA or a State with an EPA-approved sludge management program.

*Person* is an individual, association, partnership, corporation, municipality, State or Federal Agency, or an agent or employee thereof.

*Person who prepares sewage sludge* is either the person who generates sewage sludge during the treatment of domestic sewage in a treatment works or the person who derives a material from sewage sludge.

*pH* means the logarithm of the reciprocal of the hydrogen ion concentration; a measure of the acidity or alkalinity of a liquid or solid material.

*Place sewage sludge or sewage sludge placed* means disposal of sewage sludge on a surface disposal site.

*Pollutant (as defined in sludge disposal requirements)* is an organic substance, an inorganic substance, a combination of organic and inorganic substances, or pathogenic organism that, after discharge and upon exposure, ingestion, inhalation, or assimilation into an organism either directly from the environment or indirectly by ingestion through the food chain, could on the basis on information available to the Administrator of EPA, cause death, disease, behavioral abnormalities, cancer, genetic mutations, physiological malfunctions (including malfunction in reproduction) or physical deformations in either organisms or offspring of the organisms.

*Pollutant limit (for sludge disposal requirements)* is a numerical value that describes the amount of a pollutant allowed per unit amount of sewage sludge (e.g., milligrams per kilogram of total solids); the amount of pollutant that can be applied to a unit of land (e.g., kilograms per hectare); or the volume of the material that can be applied to the land (e.g., gallons per acre).

*Public contact site* is a land with a high potential for contact by the public. This includes, but is not limited to, public parks, ball fields, cemeteries, plant nurseries, turf farms, and golf courses.

*Qualified ground water scientist* is an individual with a baccalaureate or post-graduate degree in the natural sciences or engineering who has sufficient training and experience in ground water hydrology and related fields, as may be demonstrated by State registration, professional certification, or completion of accredited university programs, to make sound professional judgments regarding ground water monitoring, pollutant fate and transport, and corrective action.

*Range land* is open land with indigenous vegetation.

*Reclamation site* is drastically disturbed land that is reclaimed using sewage sludge. This includes, but is not limited to, strip mines and construction sites.

NPDES PART II STANDARD CONDITIONS  
(January, 2007)

*Risk specific concentration* is the allowable increase in the average daily ground level ambient air concentration for a pollutant from the incineration of sewage sludge at or beyond the property line of a site where the sewage sludge incinerator is located.

*Runoff* is rainwater, leachate, or other liquid that drains overland on any part of a land surface and runs off the land surface.

*Seismic impact zone* is an area that has 10 percent or greater probability that the horizontal ground level acceleration to the rock in the area exceeds 0.10 gravity once in 250 years.

*Sewage sludge* is a solid, semi-solid, or liquid residue generated during the treatment of domestic sewage in a treatment works. Sewage sludge includes, but is not limited to: domestic septage; scum or solids removed in primary, secondary, or advanced wastewater treatment processes; and a material derived from sewage sludge. Sewage sludge does not include ash generated during the firing of sewage sludge in a sewage sludge incinerator or grit and screening generated during preliminary treatment of domestic sewage in treatment works.

*Sewage sludge feed rate* is either the average daily amount of sewage sludge fired in all sewage sludge incinerators within the property line of the site where the sewage sludge incinerators are located for the number of days in a 365 day period that each sewage sludge incinerator operates, or the average daily design capacity for all sewage sludge incinerators within the property line of the site where the sewage sludge incinerators are located.

*Sewage sludge incinerator* is an enclosed device in which only sewage sludge and auxiliary fuel are fired.

*Sewage sludge unit* is land on which only sewage sludge is placed for final disposal. This does not include land on which sewage sludge is either stored or treated. Land does not include waters of the United States, as defined in 40 CFR §122.2.

*Sewage sludge unit boundary* is the outermost perimeter of an active sewage sludge unit.

*Specific oxygen uptake rate (SOUR)* is the mass of oxygen consumed per unit time per unit mass of total solids (dry weight basis) in sewage sludge.

*Stack height* is the difference between the elevation of the top of a sewage sludge incinerator stack and the elevation of the ground at the base of the stack when the difference is equal to or less than 65 meters. When the difference is greater than 65 meters, stack height is the creditable stack height determined in accordance with 40 CFR §51.100 (ii).

*State* is one of the United States of America, the District of Columbia, the Commonwealth of Puerto Rico, the Virgin Islands, Guam, American Samoa, the Trust Territory of the Pacific Islands, the Commonwealth of the Northern Mariana Islands, and an Indian tribe eligible for treatment as a State pursuant to regulations promulgated under the authority of section 518(e) of the CWA.

*Store or storage of sewage sludge* is the placement of sewage sludge on land on which the sewage sludge remains for two years or less. This does not include the placement of sewage sludge on land for treatment.

*Surface disposal site* is an area of land that contains one or more active sewage sludge units.

NPDES PART II STANDARD CONDITIONS  
(January, 2007)

*Total hydrocarbons* means the organic compounds in the exit gas from a sewage sludge incinerator stack measured using a flame ionization detection instrument referenced to propane.

*Total solids* are the materials in sewage sludge that remain as residue when the sewage sludge is dried at 103 to 105 degrees Celsius.

*Treat or treatment of sewage sludge* is the preparation of sewage sludge for final use or disposal. This includes, but is not limited to, thickening, stabilization, and dewatering of sewage sludge. This does not include storage of sewage sludge.

*Treatment works* is either a federally owned, publicly owned, or privately owned device or system used to treat (including recycle and reclaim) either domestic sewage or a combination of domestic sewage and industrial waste of a liquid nature.

*Unstable area* is land subject to natural or human-induced forces that may damage the structural components of an active sewage sludge unit. This includes, but is not limited to, land on which the soils are subject to mass movement.

*Unstabilized solids* are organic materials in sewage sludge that have not been treated in either an aerobic or anaerobic treatment process.

*Vector attraction* is the characteristic of sewage sludge that attracts rodents, flies, mosquitoes, or other organisms capable of transporting infectious agents.

*Volatile solids* is the amount of the total solids in sewage sludge lost when the sewage sludge is combusted at 550 degrees Celsius in the presence of excess air.

*Wet electrostatic precipitator* is an air pollution control device that uses both electrical forces and water to remove pollutants in the exit gas from a sewage sludge incinerator stack.

*Wet scrubber* is an air pollution control device that uses water to remove pollutants in the exit gas from a sewage sludge incinerator stack.

3. Commonly Used Abbreviations

BOD	Five-day biochemical oxygen demand unless otherwise specified
CBOD	Carbonaceous BOD
CFS	Cubic feet per second
COD	Chemical oxygen demand
Chlorine	
Cl <sub>2</sub>	Total residual chlorine
TRC	Total residual chlorine which is a combination of free available chlorine (FAC, see below) and combined chlorine (chloramines, etc.)

NPDES PART II STANDARD CONDITIONS  
(January, 2007)

TRO	Total residual chlorine in marine waters where halogen compounds are present
FAC	Free available chlorine (aqueous molecular chlorine, hypochlorous acid, and hypochlorite ion)
Coliform	
Coliform, Fecal	Total fecal coliform bacteria
Coliform, Total	Total coliform bacteria
Cont. (Continuous)	Continuous recording of the parameter being monitored, i.e. flow, temperature, pH, etc.
Cu. M/day or M <sup>3</sup> /day	Cubic meters per day
DO	Dissolved oxygen
kg/day	Kilograms per day
lbs/day	Pounds per day
mg/l	Milligram(s) per liter
ml/l	Milliliters per liter
MGD	Million gallons per day
Nitrogen	
Total N	Total nitrogen
NH <sub>3</sub> -N	Ammonia nitrogen as nitrogen
NO <sub>3</sub> -N	Nitrate as nitrogen
NO <sub>2</sub> -N	Nitrite as nitrogen
NO <sub>3</sub> -NO <sub>2</sub>	Combined nitrate and nitrite nitrogen as nitrogen
TKN	Total Kjeldahl nitrogen as nitrogen
Oil & Grease	Freon extractable material
PCB	Polychlorinated biphenyl
pH	A measure of the hydrogen ion concentration. A measure of the acidity or alkalinity of a liquid or material
Surfactant	Surface-active agent



NPDES PART II STANDARD CONDITIONS  
(January, 2007)

Temp. °C	Temperature in degrees Centigrade
Temp. °F	Temperature in degrees Fahrenheit
TOC	Total organic carbon
Total P	Total phosphorus
TSS or NFR	Total suspended solids or total nonfilterable residue
Turb. or Turbidity	Turbidity measured by the Nephelometric Method (NTU)
ug/l	Microgram(s) per liter
WET	“Whole effluent toxicity” is the total effect of an effluent measured directly with a toxicity test.
C-NOEC	“Chronic (Long-term Exposure Test) – No Observed Effect Concentration”. The highest tested concentration of an effluent or a toxicant at which no adverse effects are observed on the aquatic test organisms at a specified time of observation.
A-NOEC	“Acute (Short-term Exposure Test) – No Observed Effect Concentration” (see C-NOEC definition).
LC <sub>50</sub>	LC <sub>50</sub> is the concentration of a sample that causes mortality of 50% of the test population at a specific time of observation. The LC <sub>50</sub> = 100% is defined as a sample of undiluted effluent.
ZID	Zone of Initial Dilution means the region of initial mixing surrounding or adjacent to the end of the outfall pipe or diffuser ports.

**UNITED STATES ENVIRONMENTAL PROTECTION AGENCY  
NEW ENGLAND - REGION I  
5 POST OFFICE SQUARE, SUITE 100  
BOSTON, MASSACHUSETTS 02109-3912**

**FACT SHEET**

**DRAFT NATIONAL POLLUTANT DISCHARGE ELIMINATION SYSTEM  
(NPDES) PERMIT TO DISCHARGE TO WATERS OF THE UNITED STATES  
PURSUANT TO THE CLEAN WATER ACT (CWA)**

**NPDES PERMIT NUMBER:** MA0040291

**PUBLIC NOTICE START AND END DATES:** February 10, 2015 – March 11, 2015

**NAME AND MAILING ADDRESS OF APPLICANT:**

Genzyme Corporation  
500 Soldiers Field Road  
Allston, MA 02134

**NAME AND ADDRESS OF FACILITY WHERE DISCHARGE OCCURS:**

Genzyme Corporation  
500 Soldiers Field Road  
Allston, MA 02134

**RECEIVING WATER(S):** Charles River  
(USGS Hydrologic Code #01090001 – Charles River Basin)

**RECEIVING WATER CLASSIFICATION(S):** Class B - Warm water fishery,  
Restrictions: Combined Sewer Overflows (CSO)

**LATITUDE:** 42° 21' 67" N **LONGITUDE:** 71° 7' 0" W

**SIC CODE:** 2834 – Pharmaceutical Preparation

Contents

1.0 Proposed Action, Type of Facility and Discharge Location..... 3

2.0 Description of Treatment System and Discharges..... 3

    2.1 Outfall 001 – Reverse Osmosis Reject Water ..... 3

3.0 Receiving Water Description..... 4

4.0 Limitations and Conditions..... 5

    4.1 Permit Basis: Statutory and Regulatory Authority ..... 5

        4.1.1 General Requirements ..... 5

        4.1.2 Technology-Based Requirements ..... 6

        4.1.3 Water Quality-Based Requirements..... 6

    4.2 Antibacksliding..... 7

    4.3 Antidegradation ..... 8

    4.4 State Certification ..... 8

5.0 Explanation of Permit’s Effluent Limitations..... 8

    5.1 Outfall 001..... 8

        5.1.1 Flow ..... 8

        5.1.2 Total Copper ..... 8

        5.1.3 pH..... 10

        5.1.4 Total Suspended Solids..... 11

        5.1.5 Dissolved Oxygen..... 11

        5.1.6 Total Residual Chlorine ..... 11

        5.1.7 Total Ammonia Nitrogen..... 12

        5.1.8 Whole Effluent Toxicity ..... 12

6.0 Essential Fish Habitat Determination (EFH) ..... 13

7.0 Endangered Species Act (ESA) ..... 15

8.0 Monitoring and Reporting..... 15

9.0 State Certification Requirements ..... 17

10.0 Public Comment Period, Public Hearing, and Procedures for Final Decision ..... 17

11.0 EPA and MassDEP Contacts ..... 18

Table 1 - Outfall 001 Discharge Monitoring Data

Figure 1 - Facility Location and Outfall

Figure 2 - Water Flow Schematic

## 1.0 PROPOSED ACTION, TYPE OF FACILITY AND DISCHARGE LOCATION

The Genzyme Corporation, or “Genzyme” operates a biopharmaceutical manufacturing facility in Allston, Massachusetts. This facility is engaged in the production of therapeutic proteins for enzyme replacement. The facility was authorized to discharge reverse osmosis (RO) reject water on May 18, 2004 to the Charles River through Outfall 001, in accordance with the general permit for RO reject water (ROGP) that was issued on December 17, 2002. Genzyme initiated this discharge on May 25, 2005. Prior to this authorization, the permittee had discharged this water to the Massachusetts Water Resources Authority (MWRA) sewer, in accordance with a MWRA Sewer Use Discharge Permit.

The ROGP expired on December 17, 2007 and since EPA did not reissue the ROGP, this RO reject water discharge was authorized under this individual permit which was issued on May 1, 2009. This permit authorized the discharge of RO reject water from Outfall 001 at up to a daily maximum flow of 120,000 gallons per day (GPD) to the Charles River. The effluent is routed under the Genzyme property and connects to the Boston Water & Sewer Commission (BWSC) storm drain system at the Massachusetts Turnpike ramp, which is directed under Cambridge Street to the BWSC storm water outfall (#SDO034) to the Charles River. See **Table 1** for a summary of Outfall 001 monitoring data and **Figure 1** for a map of the facility and the outfall location.

EPA received a permit renewal application from Genzyme dated October 28, 2013 and this application was deemed complete by EPA’s letter of March 4, 2014. Therefore, this permit, although expired on April 30, 2014, has been administratively continued because Genzyme reapplied in a timely manner.

## 2.0 DESCRIPTION OF TREATMENT SYSTEM AND DISCHARGES

### 2.1 Outfall 001 – Reverse Osmosis Reject Water

To achieve the required level of water purity for its pharmaceutical production, Genzyme employs three reverse osmosis (RO) units to treat the incoming municipal drinking water, which is supplied by the MWRA. See **Figure 2** for a water flow schematic of this process. The output of these RO units is a purified water which is used in production and the RO reject water, which is discharged to Outfall 001. This reject water contains the typical parameters which are found in drinking water, but at higher concentrations.

Flow is measured onsite prior to discharge to Outfall 001. The flow meter is read daily and records are kept on-site. Grab samples, collected weekly for pH, monthly for Dissolved Oxygen (DO), and quarterly for total suspended Solids (TSS), are taken from a sample port on the discharge line prior to discharge to Outfall 001. The pH is monitored continuously at the point of discharge from the RO units and carbon dioxide is added at

this point if necessary in order for the pH to be in the permitted range of 6.5 to 9.0 standard units (s.u.) prior to being discharged to Outfall 001.

Since the MWRA water contains some residual chlorine which is detrimental to the operation of RO units, this water is dechlorinated at the site via carbon pre-treatment beds. This water also undergoes sand and media filtration prior to filtration in the RO units. Any backwash from any of these filters is discharged to the MWRA sanitary sewer and not allowed to be discharged to Outfall 001.

In 2005, the permittee discontinued the practice of in-house sanitization of its RO units. The RO unit filters are sent off-site for cleaning, so no cleaning chemicals are added to the RO system at the facility. Prior to reinstallation onto the RO units, the cleaned components are triple rinsed with purified water which is discharged to the MWRA sewer. The discharge of wastewaters to the Charles River from any and all cleaning or backwashing of these RO units or any of its components is not authorized by this permit. TRC has not been detected in the permittee's effluent since 2005.

### 3.0 RECEIVING WATER DESCRIPTION

---

---

The Massachusetts Surface Water Quality Standards, found at 314 CMR 4.00, classify this segment of the Charles River, which runs from the Watertown Dam to the Boston University Bridge in Boston (Segment MA72-36), as a Class B water (314 CMR 4.00)<sup>1</sup>.

Class B waters are described in the SWQS [314 CMR 4.05(3)(b)] as “designated as a habitat for fish, other aquatic life, and wildlife, including for their reproduction, migration, growth and other critical functions, and for primary and secondary contact recreation. Where designated in 314 CMR 4.06, they shall be suitable as a source of public water supply with appropriate treatment (“Treated Water Supply”) and suitable for irrigation and other agricultural uses and for compatible industrial cooling and process uses. These waters shall have consistently good aesthetic value.” A warm water fishery is defined in the MA SWQS as “waters in which the maximum mean monthly temperature generally exceeds 68° F (20° C) during the summer months and are not capable of sustaining a year-round population of cold water stenothermal aquatic life” (314 CMR 4.02).

Sections 305(b) and 303(d) of the CWA require that States complete a water quality inventory and develop a list of impaired waters. Specifically, Section 303(d) of the CWA requires States to identify those water bodies that are not expected to meet surface water quality standards after the implementation of technology-based controls, and as such, require the development of a Total Maximum Daily Load (TMDL) for each pollutant that is prohibiting a designated use(s) from being attained. In Massachusetts, these two evaluations have been combined into an Integrated List of Waters. The integrated list format provides the status of all assessed waters in a single, multi-part list.

---

<sup>1</sup> <http://www.mass.gov/eea/docs/dep/water/laws/i-thru-z/tblfig.pdf>

This segment of the Charles River does not always meet the state water quality standards prescribed for Class B waters, especially after wet weather. This segment of the Charles River is listed on the *Final Massachusetts Year 2012 Integrated List of Waters*<sup>2</sup> as a Category 5 waterbody, which are those classified as “Waters requiring a TMDL”. This segment is impaired for chlorophyll-*a*, DDT, *Escherichia coli*, fishes bioassessments, nutrient/eutrophication biological indicators, oil and grease, dissolved oxygen, PCB in fish tissue, high pH, total phosphorus, secchi disk transparency, and sediment bioassays (acute toxicity). This segment also contains non-native aquatic plants and may act as a fish passage barrier and have other flow regime alterations, although these last three items are non-pollutant impairments for which a Total Maximum Daily Load (TMDL) is not required. The list of impairments for this segment of the Charles River remains the same in the *Proposed Massachusetts Year 2014 Integrated List of Waters*.

MassDEP is required under the CWA to develop a TMDL for waterbodies that are identified as impaired. A TMDL is essentially a pollution budget designed to restore the health of a waterbody. A TMDL first identifies the source(s) of the pollutant from direct and indirect discharges in order to then determine the maximum amount of pollutant (including a margin of safety) that can be discharged to a specific waterbody while maintaining water quality standards for designated uses. It then outlines a plan to meet the goal. In 2007, the MassDEP finalized the Lower Charles River Basin TMDL for Phosphorus and the Charles River Watershed Pathogen TMDL. The sources of phosphorus and pathogens are mainly from stormwater, combined sewer overflows (CSO), illicit sanitary sewage discharges, and discharges from upstream Publicly Owned Treatment Works (POTWs). This discharge is not expected to be a source of fecal coliform and total phosphorus. Therefore, no specific requirements have been included in this permit for these parameters to meet the TMDL requirements.

#### 4.0 LIMITATIONS AND CONDITIONS

---

---

The effluent limitations, monitoring requirements, and any implementation schedule, if required, may be found in Part 1 (Effluent Limitations and Monitoring Requirements) of the Draft Permit. The permit reapplication is part of the administrative file of this permit.

##### 4.1 Permit Basis: Statutory and Regulatory Authority

###### 4.1.1 General Requirements

The Clean Water Act (CWA) prohibits the discharge of pollutants to waters of the United States without a National Pollutant Discharge Elimination System (NPDES) permit unless such a discharge is otherwise authorized by the CWA. The NPDES permit is the mechanism used to implement technology and water quality-based effluent limitations and other requirements including monitoring and reporting. This draft NPDES permit was developed in accordance with various statutory and regulatory requirements established pursuant to the CWA and any applicable State regulations. The regulations

---

<sup>2</sup> <http://www.mass.gov/eea/agencies/massdep/water/watersheds/total-maximum-daily-loads-tmdls.html>

governing the EPA NPDES permit program are generally found at 40 CFR Parts 122, 124, 125, and 136.

When developing permit limits, EPA must consider the most recent technology-based treatment and water quality-based requirements. Subpart A of 40 CFR Part 125 establishes criteria and standards for the imposition of technology-based treatment requirements in permits under Section 301(b) of the CWA, including the application of EPA-promulgated effluent limitations and case-by-case determinations of effluent limitations under Section 402(a)(1) of the CWA. EPA is required to consider technology and water quality-based requirements as well as all limitations and requirements in the existing permit when developing permit limits.

#### *4.1.2 Technology-Based Requirements*

Technology-based treatment requirements represent the minimum level of control that must be imposed under Sections 301(b) and 402 of the CWA (see 40 CFR §125 Subpart A) to meet best practicable control technology currently available (BPT) for conventional pollutants and some metals, best conventional control technology (BCT) for conventional pollutants, and best available technology economically achievable (BAT) for toxic and non-conventional pollutants. There are no effluent limitations guidelines which are applicable to this facility.

In general, the statutory deadline for non-POTW, technology-based effluent limitations must be complied with as expeditiously as practicable but in no case later than three years after the date such limitations are established and in no case later than March 31, 1989 (see 40 CFR §125.3(a)(2)). Compliance schedules and deadlines not in accordance with the statutory provisions of the CWA cannot be authorized by a NPDES permit.

In the absence of published technology-based effluent guidelines, the permit writer is authorized under Section 402(a)(1)(B) of the CWA to establish effluent limitations on a case-by-case basis using best professional judgment (BPJ).

#### *4.1.3 Water Quality-Based Requirements*

Water quality-based limitations are required in NPDES permits when EPA and the State determine that effluent limits more stringent than technology-based limits are necessary to maintain or achieve state or federal water quality standards (WQS). See Section 301(b)(1)(C) of the CWA.

Receiving water requirements are established according to numerical and narrative standards adopted under state law for each water quality classification. When using chemical-specific numeric criteria to develop permit limits, both the acute and chronic aquatic-life criteria, expressed in terms of maximum allowable in-stream pollutant concentration, are used. Acute aquatic-life criteria are considered applicable to daily time periods (maximum daily limit) and chronic aquatic-life criteria are considered applicable to monthly time periods (average monthly limit). Chemical-specific limits are allowed

under 40 CFR §122.44(d)(1) and are implemented under 40 CFR §122.45(d). The Region has established, pursuant to 40 CFR §122.45(d)(2), a maximum daily limit and average monthly discharge limits for specific chemical pollutants.

A facility's design flow is used when deriving constituent limits for daily and monthly time periods as well as weekly periods where appropriate. Also, the dilution provided by the receiving water is factored into this process where appropriate. Narrative criteria from the state's water quality standards are often used to limit toxicity in discharges where (a) a specific pollutant can be identified as causing or contributing to the toxicity but the state has no numeric standard; or (b) toxicity cannot be traced to a specific pollutant.

EPA regulations require NPDES permits to contain effluent limits more stringent than technology-based limits where more stringent limits are necessary to maintain or achieve state or federal WQS. The permit must address any pollutant or pollutant parameter (conventional, non-conventional, toxic and whole effluent toxicity) that is or may be discharged at a level that causes or has "reasonable potential" to cause or contribute to an excursion above any water quality criterion. See 40 CFR §122.44(d)(1). An excursion occurs if the projected or actual in-stream concentration exceeds the applicable criterion. In determining reasonable potential, EPA considers (a) existing controls on point and non-point sources of pollution; (b) pollutant concentration and variability in the effluent and receiving water as determined from the permit application, Monthly Discharge Monitoring Reports (DMRs), and State and Federal Water Quality Reports; (c) sensitivity of the species to toxicity testing; (d) known water quality impacts of processes on wastewater; and, where appropriate, (e) dilution of the effluent in the receiving water.

WQS consist of three parts: (a) beneficial designated uses for a water body or a segment of a water body; (b) numeric and/or narrative water quality criteria sufficient to protect the assigned designated use(s); and (c) antidegradation requirements to ensure that once a use is attained it will not be degraded. The Massachusetts Surface Water Quality Standards (MA SWQS), found at 314 CMR 4.00, include these elements. The state will limit or prohibit discharges of pollutants to surface waters to assure that surface water quality standards of the receiving waters are protected and maintained or attained. These standards also include requirements for the regulation and control of toxic constituents and require that EPA criteria, established pursuant to Section 304(a) of the CWA, shall be used unless a site-specific criterion is established. The conditions of the permit reflect the goal of the CWA and EPA to achieve and then to maintain WQS.

#### 4.2 Antibacksliding

A permit may not be renewed, reissued or modified with less stringent limitations or conditions than those contained in the previous permit unless in compliance with the anti-backsliding requirements of the CWA [see Sections 402(o) and 303(d)(4) of the CWA and 40 CFR §122.44(l)(1 and 2)]. EPA's antibacksliding provisions prohibit the relaxation of permit limits, standards, and conditions except under certain circumstances. Effluent limits based on BPJ, water quality, and state certification requirements must also meet the antibacksliding provisions found at Section 402(o) and 303(d)(4) of the CWA.



Since all proposed permit conditions are at least as stringent as those of the current permit, the antibacksliding provisions for this permit reissuance are being met.

#### 4.3 Antidegradation

Federal regulations found at 40 CFR Section 131.12 require states to develop and adopt a statewide antidegradation policy which maintains and protects existing instream water uses and the level of water quality necessary to protect the existing uses, and maintains the quality of waters which exceed levels necessary to support propagation of fish, shellfish, and wildlife and to support recreation in and on the water. The Massachusetts Antidegradation Regulations are found at 314 CMR 4.04. There are no new or increased discharges being proposed with this permit reissuance. Therefore, EPA believes that the MassDEP is not required to conduct an antidegradation review regarding this permit reissuance.

#### 4.4 State Certification

Under Section 401 of the CWA, EPA is required to obtain certification from the state in which the discharge is located that all water quality standards or other applicable requirements of state law, in accordance with Section 301(b)(1)(C) of the CWA, are satisfied. EPA permits are to include any conditions required in the state's certification as being necessary to ensure compliance with state water quality standards or other applicable requirements of state law. (See CWA Section 401(a) and 40 CFR §124.53(e).) Regulations governing state certification are set out at 40 CFR §124.53 and §124.55. EPA regulations pertaining to permit limits based upon water quality standards and state requirements are contained in 40 CFR §122.44(d).

### 5.0 EXPLANATION OF PERMIT'S EFFLUENT LIMITATIONS

---

#### 5.1 Outfall 001

##### *5.1.1 Flow*

The current permit established effluent flow limits based on its operational needs of a monthly average of 66,000 gallons per day (GPD) and a daily maximum of 120,000 GPD. During the monitoring period of May 2009 through February 2014, the effluent flows of RO reject water were in the range of 16,211 to 116,248 GPD, with no violations of the permitted limits. Since these permit limits are adequate to service the needs of this facility, they will remain in the permit.

##### *5.1.2 Total Copper*

Copper may be toxic to aquatic life at low concentrations, so the ROGP contained numerical limits for total recoverable copper and specified an appropriate method of analysis. Total copper limits in the ROGP were established at a monthly average of 516

µg/l and a daily maximum of 730 µg/l for those discharges in the 100 – 1000 dilution range. The current permit established a monitor only requirement for total copper with no limits reflecting the fact that most effluent samples for copper were low relative to the prior limits or not detected.

Massachusetts SWQS require that the available effluent dilution be calculated based upon the 7Q10 flow of the receiving water (314 CMR 4.03(3)(a)). The 7Q10 flow is the mean low flow over seven consecutive days, occurring every ten years. Use of the 7Q10 flow allows for the calculation of the available dilution under critical flow (worst-case) conditions, which in turn results in the derivation of conservative water quality-based effluent limitations.

The Charles River 7Q10 estimate was provided by the United States Geological Survey (USGS) Streamstats program. The WQB limits for copper that would apply for this discharge are hardness dependent and have been calculated below to reflect the water quality criteria published in the Federal Register on December 10, 1998 (National Recommended Water Quality Criteria, December 10, 1998, FR Vol. 63, No.237) and dilution factors based on the permitted facility flows.

The acute and chronic, total copper water quality criteria that would apply to this discharge are derived from the following equations<sup>3</sup>:

$$\text{Chronic: } e(m_c [\ln(h)] + b_c) \quad \text{Acute: } e(m_a [\ln(h)] + b_a)$$

Where:  $m_c$  and  $b_c$  are the parameters for calculating the dissolved metal chronic criterion;  
 $m_a$  and  $b_a$  are the parameters for calculating the dissolved metal acute criterion;  
 $h$  is the hardness of the receiving water;  $\ln$  is the natural logarithm

$$\text{For copper: } m_c = 0.8545; \quad b_c = -1.702; \quad m_a = 0.9422; \quad b_a = -1.70$$

Estimated hardness = 50 mg/l as CaCO<sub>3</sub> [Estimate based on an average of upstream hardness values in the Charles River from Whole Effluent Toxicity Testing reports submitted for the Town of Medfield's NPDES Permit (#MA0100978) between the period of 2009 and 2012]

The following is the calculation of the applicable water quality based copper criteria for this discharge:

$$\begin{array}{l} \text{Thus;} \\ e(.8545 [(\ln 50)] - 1.702) \qquad e(.9422 [(\ln 50)] - 1.70) = \\ 5.2 \mu\text{g/l} \qquad \qquad \qquad 7.3 \mu\text{g/l} \end{array}$$

To achieve the applicable effluent limits, the following dilution factors were used:

<sup>3</sup> National Recommended Water Quality Criteria, December 10, 1998, FR Vol. 63, No.237

Charles River 7Q10 flow at Waltham (USGS gage# 0110450): **9.2 MGD**

Average Flow = 66,000 GPD or **0.066 MGD**; Maximum Flow = **0.12 MGD**

average flow dilution:  $\frac{9.2 + 0.066}{0.066} = 140$       maximum flow dilution:  $\frac{9.2 + 0.12}{0.12} = 78$

Water Quality Based Effluent Limitations:

Monthly Average (chronic)	Daily Maximum (acute)
140 (5.2) = 730 $\mu\text{g/l}$ = <b>0.73 mg/l</b>	78 (7.3) = 570 $\mu\text{g/l}$ = <b>0.57 mg/l</b>

These dissolved copper values must be divided by a conversion factor to attain the appropriate total recoverable copper limits. The chronic value corresponds to a monthly average limit and the acute to a daily maximum limit.

Monthly average:  $0.73 \text{ mg/l} / 0.96 = \mathbf{0.76 \text{ mg/l}}$   
 Daily Maximum:  $0.57 \text{ mg/l} / 0.96 = \mathbf{0.59 \text{ mg/l}}$

During the monitoring period, the DMRs have shown effluent total copper levels in the range of non-detect to 0.10 mg/l. Based on these results, there is not a reasonable potential that this discharge will violate either one of these values. Therefore, no permit limits are established, although the quarterly monitoring requirement has been maintained for total copper to verify that the actual effluent levels remain well below these values.

### 5.1.3 pH

The pH range in the ROGP was previously limited to the Class B range of 6.5 to 8.3 s.u. which is the range required by state WQS and which can be found at 314 CMR 4.05(3)(b)3. The permittee had previously demonstrated that its source water is often above 9.0 s.u. and that the effluent could not always be within this permitted range without pH adjustment. During the monitoring period, the effluent pH has been reported in the range of 6.5 to 8.9 s.u. In August of 2008, the permittee installed a pH treatment system which uses a carbon dioxide injection system for pH adjustment. The permittee had previously installed an automatic diversion system that would divert flow from outfall 001 back to the MWRA if the pH level was above the permitted level. The permittee has noted that this diversion option is no longer available.

EPA has maintained the current permit's pH upper range at 9.0 s.u. In general, this is the highest level allowed in EPA's technology guidelines. EPA expects that the instream State WQS of 8.3 s.u. would still be met, due to the significant amount of dilution available to this discharge. The draft permit continues to require weekly grab samples for pH and a reporting of the monthly pH range in the DMRs.

#### 5.1.4 *Total Suspended Solids*

Since RO systems concentrate solids in the intake water, the original ROGP had established permit limits of 30 mg/l (monthly average) and 45 mg/l (daily maximum) for TSS, based on BPJ, as well as a monitoring requirement for the mass of TSS discharged. All monitoring results during the monitoring period showed TSS levels to be consistently not detected. In order to assure that the filtration mechanisms are working properly and that suspended solids do not pass through to the effluent, the quarterly TSS monitoring requirement has been maintained in the draft permit. The sample type continues to be a quarterly grab sample, because there is not expected to be significant variability in the discharge of TSS over time to necessitate composite sampling.

#### 5.1.5 *Dissolved Oxygen*

Consistent with the Class B State WQS (314 CMR 4.05(3)(b)1), there is a minimum dissolved oxygen (DO) level of 6.0 mg/l required by the permit, to be monitored once per month. During the recent monitoring period, DMRs have shown the DO to be within the range of 9.0 to 20 mg/l. In order to assure that the minimum level of 6.0 mg/l is met, this monthly monitoring requirement for DO is maintained in the draft permit.

#### 5.1.6 *Total Residual Chlorine*

The ROGP had a limit for Total Residual Chlorine (TRC) in consideration of the potential for chemicals containing chlorine that could be used to clean RO units. These limits were established as a monthly average of 0.11 mg/l and a daily maximum of 0.20 mg/l. The permittee does not conduct cleaning of RO system components on site, as noted earlier and the 2009 permit required monitoring for TRC with no limit since previous monitoring had not detected TRC in the effluent.

Since the City of Cambridge's water supply, the source of the water used at this facility, is chlorinated, the permittee treats this water with carbon filtration prior to putting it through its RO system. During the monitoring period, TRC has only been detected three times at concentrations of 40, 60, and 640 µg/l, with the last value detected in November 2013.

Although the permittee could not verify exactly what happened to lead to the TRC result of 640 µg/l, the permittee believes that this detection was related to an operational upset related to the RO treatment systems at the site. It is believed that the event causing this elevated TRC level is attributed to the incorrect manipulation of inlet and outlet hoses on the deionizing (DI) beds of the RO system. An operator inadvertently installed inlet and outlet hoses backwards. Due to the error, incoming purified water to the DI bed was now being sent through the outlet. This forced the resin in the DI bed to circulate throughout the reverse osmosis system.

The function of the resin is for ion exchange where cations and anions are attached to the resin depending on their charge. When the resin was being sent into the system, the

positive and negative charged ions were released into the water, some of which were eventually captured in the RO reject water. The timing of this event specifically coincides with the high TRC detection in the November 2013 sample.

The permittee has since implemented several corrective actions which will prevent this from occurring, including fabricating hose attachments specific to inlet and outlet connections. The fabrication of these attachments will make it impossible for the inlet hoses to be attached to the outlet connection ports and vice versa.

The following calculation shows what the water quality based TRC limits would be based on actual dilution:

Water Quality Criteria<sup>4</sup>: Freshwater – Chronic: 0.011 mg/l; Acute: 0.019 mg/l

Effluent Limitations:

Monthly Average:

Daily Maximum:

$$140 (.011 \text{ mg/l}) = \mathbf{1.54 \text{ mg/l}} \quad 78 (0.019 \text{ mg/l}) = \mathbf{1.48 \text{ mg/l}}$$

Since the majority of monitoring has resulted in no detections of TRC, the draft permit has maintained the monthly monitoring requirement for TRC to confirm that the carbon units are removing residual chlorine adequately in the source water and that any detected TRC levels are within the calculated water quality-based permit limits.

#### 5.1.7 Total Ammonia Nitrogen

When RO units are bleached or cleaned with hypochlorite or other chlorine based compounds, chloramines are created, resulting in the reject water containing ammonia. Therefore, Total Ammonia Nitrogen (TAN) monitoring was required in the current permit. The permittee now conducts cleaning of its RO system components off-site and then triple rinses these components with purified water which is then directed to the MWRA sewer. During the monitoring period, TAN readings in the effluent have ranged from non-detect to 1.3 mg/l, with an average reading of 0.31 mg/l. Although this segment of the Charles River is impaired for nutrient/eutrophication biological indicators, phosphorus is the limiting nutrient controlling plant growth and is typically the cause of eutrophication-related impairments. Since the effluent ammonia nitrogen levels are typical of those present in the Charles River, no limit has been established, but the monthly monitoring requirement has been maintained in the draft permit.

#### 5.1.8 Whole Effluent Toxicity

Whole effluent toxicity (WET) testing is conducted to assess whether certain effluents, often containing potentially toxic pollutants, are discharged in a combination which produces a toxic amount of pollutants in a receiving water. Therefore, toxicity testing

<sup>4</sup> National Recommended Water Quality Criteria, December 10, 1998, FR Vol. 63, No.237

may be used in conjunction with pollutant specific control procedures to control the discharge of toxic pollutants.

There are two specific sources of legal authority which explain how regulatory authorities have the legal basis for establishing toxicity testing requirements and toxicity-based permit limits in NPDES permits. Sections 402(a)(2) and 308(a) of the CWA provide EPA and States with the authority to require toxicity testing data. Section 308 specifically describes biological monitoring methods as techniques which may be used to carry out objectives of the Act. Under certain State narrative water quality standards, and Sections 301, 303 and 402 of the CWA, EPA and the States may establish toxicity-based limits to implement the narrative "no toxics in toxic amounts".

The regulations at 40 CFR Part 122.44(d)(ii) state, "When determining whether a discharge causes, has the reasonable potential to cause, or contributes to an in-stream excursion above a narrative or numeric criteria within a State water quality standard, the permitting authority shall use procedures which account for existing controls on point and non-point sources of pollution...(including) the sensitivity of the species to toxicity testing..." The current permit has no WET testing requirement.

Based on regulations at 40 CFR 122.44(d)(1) and the MA SWQS [(314 CMR 4.05(5)(e))], NPDES permits must include limitations for WET when there is reasonable potential for discharges to cause or contribute pollutants in concentrations or combinations that are toxic to humans, aquatic life, or wildlife.

In this draft permit, EPA has determined that there is not a reasonable potential for this discharge to exhibit a toxic response in the receiving water. This discharge is not believed to contain toxic substances in toxic amounts and is considered a low risk for toxicity potential. The permittee uses MWRA drinking water for its process and treats this water for solids and chlorine prior to sending it through RO units for additional purification. Although the RO reject water that is discharged concentrates the level of pollutants in the source water, the characteristics of this drinking water, the treatment it undergoes prior to the RO filtration system, and the historical DMR effluent data of this permit does not indicate a reasonable potential for toxicity in this discharge.

## 6.0 ESSENTIAL FISH HABITAT DETERMINATION (EFH)

Under the 1996 Amendments (PL 104-267) to the Magnuson-Stevens Fishery Conservation and Management Act (16 U.S.C. § 1801 et seq. (1998)), EPA is required to consult with the National Marine Fisheries Services (NMFS) if EPA's action or proposed actions that it funds, permits, or undertakes, may adversely impact any essential fish habitat such as: waters and substrate necessary to fish for spawning, breeding, feeding, or growth to maturity (16 U.S.C. § 1802 (10)). Adversely impact means any impact which reduces the quality and/or quantity of EFH (50 C.F.R. § 600.910 (a)). Adverse effects may include direct (e.g., contamination or physical disruption), indirect (e.g., loss of prey, reduction in species' fecundity), site-specific or habitat-wide impacts, including individual, cumulative, or synergistic consequences of actions.

EFH is only designated for species for which federal fisheries management plans exist (16 U.S.C. § 1855(b) (1) (A)). EFH designations for New England were approved by the U.S. Department of Commerce on March 3, 1999. The following is a list of the EFH species and applicable lifestage(s) for the area that includes Massachusetts Bay, to which the Charles River discharges:

Species	Eggs	Larvae	Juveniles	Adults
Atlantic cod ( <i>Gadus morhua</i> )	X	X	X	X
haddock ( <i>Melanogrammus aeglefinus</i> )	X	X		
pollock ( <i>Pollachius virens</i> )	X	X	X	X
whiting ( <i>Merluccius bilinearis</i> )	X	X	X	X
red hake ( <i>Urophycis chuss</i> )	X	X	X	X
white hake ( <i>Urophycis tenuis</i> )	X	X	X	X
winter flounder ( <i>Pseudopleuronectes americanus</i> )	X	X	X	X
yellowtail flounder ( <i>Pleuronectes ferruginea</i> )	X	X	X	X
windowpane flounder ( <i>Scophthalmus aquosus</i> )	X	X	X	X
American plaice ( <i>Hippoglossoides platessoides</i> )	X	X	X	X
ocean pout ( <i>Macrozoarces americanus</i> )	X	X	X	X
Atlantic halibut ( <i>Hippoglossus hippoglossus</i> )	X	X	X	X
Atlantic sea scallop ( <i>Placopecten magellanicus</i> )	X	X	X	X
Atlantic sea herring ( <i>Clupea harengus</i> )		X	X	X
long finned squid ( <i>Loligo pealei</i> )	n/a	n/a	X	X
short finned squid ( <i>Illex illecebrosus</i> )	n/a	n/a	X	X
Atlantic butterfish ( <i>Peprilus triacanthus</i> )	X	X	X	X
Atlantic mackerel ( <i>Scomber scombrus</i> )	X	X	X	X
summer flounder ( <i>Paralichthys dentatus</i> )				X
scup ( <i>Stenotomus chrysops</i> )	n/a	n/a	X	X
black sea bass ( <i>Centropristus striata</i> )	n/a		X	X
surf clam ( <i>Spisula solidissima</i> )	n/a	n/a	X	X
bluefin tuna ( <i>Thunnus thynnus</i> )			X	X

A review of the relevant essential fish habitat information provided by NMFS indicates that EFH has been designated for 23 managed species within the NMFS boundaries encompassing Massachusetts Bay. It is possible that a number of these species utilize these receiving waters for spawning, while others are present seasonally.

Based on the available information, EPA has determined that Genzyme's operation, as restricted by the draft permit conditions, will not directly or indirectly cause adverse effects to EFH species or their habitat, because the draft permit contains limits that are protective of the aquatic species in the Charles River. Any RO unit cleaning wastewaters and filtering equipment backwashes are prohibited from being discharged by this permit to the Charles River. During the public comment period, EPA has provided a copy of the Draft Permit and Fact Sheet to NMFS for consultation with NMFS under Section 305(b)(2) of the Magnuson-Stevens Act for EFH.

## 7.0 ENDANGERED SPECIES ACT (ESA)

Section 7(a) of the Endangered Species Act of 1973, as amended (ESA) grants authority to and imposes requirements upon Federal agencies regarding endangered or threatened species of fish, wildlife, or plants ("listed species") and habitat of such species that has been designated as critical (a "critical habitat"). The ESA requires every Federal agency, in consultation with and with the assistance of the Secretary of Interior, to insure that any action it authorizes, funds, or carries out, in the United States or upon the high seas, is not likely to jeopardize the continued existence of any listed species or result in the destruction or adverse modification of critical habitat. The United States Fish and Wildlife Service (USFWS) typically administer Section 7 consultations for bird, terrestrial, and freshwater aquatic species. The NMFS typically administers Section 7 consultations for marine species and anadromous fish.

EPA has reviewed the federal endangered or threatened species of fish, wildlife, and plants to see if any such listed species might potentially be impacted by the reissuance of this NPDES permit and has not found any such listed species. EPA has determined that there are no species of concern present in the vicinity of the outfall from this Facility. Therefore, EPA does not need to formally consult with NMFS or USFWS in regard to the provisions of the ESA.

EPA has structured the proposed limits to be sufficiently stringent to assure that Water Quality Standards will be met. The effluent limits established in this permit ensure the protection of aquatic life and maintenance of the receiving water as an aquatic habitat. During the public comment period, EPA has provided a copy of the Draft Permit and Fact Sheet to both NMFS and USFWS.

## 8.0 MONITORING AND REPORTING

The effluent monitoring requirements have been established to yield data representative of the discharge under authority of Section 308 (a) of the CWA in accordance with 40 CFR §§122.41 (j), 122.44 (l), and 122.48.



The Draft Permit requires the permittee to report monitoring results obtained during each calendar month in the Discharge Monitoring Reports (DMRs) no later than the 15th day of the month following the completed reporting period.

The Draft Permit includes new provisions related to electronic DMR submittals to EPA and the State. The Draft Permit requires that, no later than six months after the effective date of the permit, the permittee submit all DMRs to EPA using NetDMR, unless the permittee is able to demonstrate a reasonable basis, such as technical or administrative infeasibility, that precludes the use of NetDMR for submitting DMRs and reports (“opt-out request”).

In the interim (until six months from the effective date of the permit), the permittee may either submit monitoring data to EPA in hard copy form, or report electronically using NetDMR.

NetDMR is a national web-based tool for regulated Clean Water Act permittees to submit DMRs electronically via a secure Internet application to U.S. EPA through the Environmental Information Exchange Network. NetDMR allows participants to discontinue mailing in hard copy forms under 40 CFR § 122.41 and § 403.12. NetDMR is accessed from the following url: <http://www.epa.gov/netdmr>. Further information about NetDMR can be found on the EPA Region 1 NetDMR website located at <http://www.epa.gov/region1/npdes/netdmr/index.html>.

EPA currently conducts free training on the use of NetDMR, and anticipates that the availability of this training will continue to assist permittees with the transition to use of NetDMR. To learn more about upcoming trainings, please visit the EPA Region 1 NetDMR website <http://www.epa.gov/region1/npdes/netdmr/index.html>.

The Draft Permit also includes an “opt-out” request process. Permittees who believe they cannot use NetDMR due to technical or administrative infeasibilities, or other logical reasons, must demonstrate the reasonable basis that precludes the use of NetDMR. These permittees must submit the justification, in writing, to EPA at least sixty (60) days prior to the date the facility would otherwise be required to begin using NetDMR. Opt-outs become effective upon the date of written approval by EPA and are valid for twelve (12) months from the date of EPA approval. The opt-outs expire at the end of this twelve (12) month period. Upon expiration, the permittee must submit DMRs to EPA using NetDMR, unless the permittee submits a renewed opt-out request sixty (60) days prior to expiration of its opt-out, and such a request is approved by EPA.

In most cases, reports required under the permit shall be submitted to EPA as an electronic attachment through NetDMR, subject to the same six month time frame and opt-out provisions as identified for NetDMR. Certain exceptions are provided in the permit such as for the submittal of pre-treatment reports and for providing written notifications required under the Part II Standard Permit Conditions. Once a permittee begins submitting reports to EPA using NetDMR, it will no longer be required to submit

hard copies of DMRs or other reports to EPA and will no longer be required to submit hard copies of DMRs to MassDEP. However, permittees must continue to send hard copies of reports other than DMRs to MassDEP until further notice from MassDEP. Until electronic reporting using NetDMR begins, or for those permittees that receive written approval from EPA to continue to submit hard copies of DMRs, the Draft Permit requires that submittal of DMRs and other reports required by the permit continue in hard copy format. Hard copies of DMRs must be postmarked no later than the 15th day of the month following the completed reporting period.

## 9.0 STATE CERTIFICATION REQUIREMENTS

---

EPA may not issue a permit unless the State Water Pollution Control Agency with jurisdiction over the receiving waters certifies that the effluent limitations contained in the permit are stringent enough to assure that the discharge will not cause the receiving water to violate State WQS. MassDEP has reviewed the draft permit and advised EPA that the limitations are adequate to protect water quality. EPA has requested permit certification by the State pursuant to 40 CFR 124.53 and expects that the draft permit will be certified.

## 10.0 PUBLIC COMMENT PERIOD, PUBLIC HEARING, AND PROCEDURES FOR FINAL DECISION

---

All persons, including applicants, who believe any condition of the draft permit is inappropriate must raise all issues and submit all available arguments and all supporting material for their arguments in full by the close of the public comment period, to George Papadopoulos, U.S. EPA, Office of Ecosystem Protection, Industrial Permits Section, Mailcode OEP 06-1, 5 Post Office Square, Suite 100, Boston, Massachusetts 02109-3912. Any person, prior to such date, may submit a request in writing for a public hearing to consider the draft permit to EPA and MassDEP. Such requests shall state the nature of the issues proposed to be raised in the hearing. A public hearing may be held after at least thirty days public notice whenever the Regional Administrator finds that response to this notice indicates significant public interest. In reaching a final decision on the draft permit the Regional Administrator will respond to all significant comments and make these responses available to the public at EPA's Boston office.

Following the close of the comment period, and after any public hearings, if such hearings are held, the EPA will issue a Final Permit decision and forward a copy of the final decision to the applicant and each person who has submitted written comments or requested notice. Within 30 days following the notice of the Final Permit decision, any interested person may submit a petition for review of the permit to EPA's Environmental Appeals Board consistent with 40 CFR § 124.19.

## 11.0 EPA AND MASSDEP CONTACTS

---

Additional information concerning the draft permit may be obtained between the hours of 9:00 a.m. and 5:00 p.m., Monday through Friday, excluding holidays, from the EPA and MassDEP contacts below:

George Papadopoulos, Industrial Permits Section  
5 Post Office Square - Suite 100 - Mailcode OEP 06-1  
Boston, MA 02109-3912  
Papadopoulos.george@epa.gov  
Telephone: (617) 918-1579 FAX: (617) 918-1505

Cathy Vakalopoulos, Massachusetts Department of Environmental Protection  
Surface Water Discharge Permit Program  
1 Winter Street, Boston, Massachusetts 02108  
catherine.vakalopoulos@state.ma.us  
Telephone: (617) 348-4026; FAX: (617) 292-5696

February 2, 2015  
Date

Ken Moraff, Director  
Office of Ecosystem Protection  
U.S. Environmental Protection Agency

**Table 1: Discharge Monitoring Data****Genzyme Corporation - Outfall 001**

Monitoring Period End Date	Flow		Total Residual Chlorine		DO	Copper	TSS	
	MGD	MGD	µg/l	µg/l	mg/l	µg/l	mg/l	
	Mon Avg	Daily Max	Mon Avg	Daily Max		Daily Max	Min	max
May-09	47416	89318	0	0	15			
Jun-09	40488	57899	0	0	15			
Jul-09	22327	37478	0	0	10	10	0	0
Aug-09	33489	83932	0	0	10			
Sep-09	48193	68821	0	0	12			
Oct-09	55576	89467	0	0	12	35	0	0
Nov-09	52035	88944	0	0	12			
Dec-09								
Jan-10	52828	89168	0	0	20	14	0	0
Feb-10	64683	116248	0	0	16			
Mar-10	53803	115724	0	0	16			
Apr-10	38848	66427	0	0	16	0	0	0
May-10	47369	68223	0	0	15			
Jun-10	43152	63884	0	0	14			
Jul-10	48415	88794	0	0	14	0	0	0
Aug-10	56222	78247	0	0	10			
Sep-10	50443	74955	0	0	12			
Oct-10	41679	68821	0	0	9.6	0	0	0
Nov-10	42006	61191	0	0	11			
Dec-10	49308	79443	0	0	10			
Jan-11	31159	64108	0	0	13	0	0	0
Feb-11	32564	69794	0	0	16			
Mar-11	35818	47352	40	40	16			
Apr-11	35038	67325	0	0	15	0	0	0
May-11	33844	52139	0	0	15			
Jun-11	32842	78995	0	0	15			
Jul-11	30983	81837	60	60	13	0	0	0
Aug-11	26137	41891	0	0	13			
Sep-11	31899	41966	0	0	9			
Oct-11	33019	85428	0	0	12	20	0	0
Nov-11	26559	38001	0	0	14			
Dec-11	29296	38375	0	0	16			
Jan-12	16211	59545	0	0	14	17	0	0
Feb-12	20032	43387	0	0	20			

Mar-12	21149	45856	0	0	18			
Apr-12	22428	40769	0	0	17	16	0	0
May-12	21159	32249	0	0	13			
Jun-12	19401	28351	0	0	14			
Jul-12	19073	24611	0	0	14	16	0	0
Aug-12	21881	31568	0	0	12			
Sep-12	23326	31867	0	0	10			
Oct-12	25827	35383	0	0	10	19	0	0
Nov-12	29711	39772	0	0	11.5			
Dec-12	19507	31119	0	0	16			
Jan-13	19025	27145	0	0	15	10	0	0
Feb-13	21709	30670	0	0	16			
Mar-13	40912	57600	0	0	11			
Apr-13	35649	56478	0	0	18	0	0	0
May-13	25583	47950	0	0	17			
Jun-13	34066	59919	0	0	16			
Jul-13	38138	47202	0	0	14	19	0	0
Aug-13	45538	69270	0	0	11			
Sep-13	50593	87212	0	0	10			
Oct-13	38300	52877	0	0	10	0	0	0
Nov-13	39324	68297	640	640	14			
Dec-13	23713	55506	0	0	15			
Jan-14	44453	58722	0	0	18	100	0	0
Feb-14	48079	73085	0	0	15			
2009 Permit Limits	66,000 gpd	120,000 gpd	Report	Report	6.0 mg/l min	Report µg/l	Report mg/l	Report mg/l
Minimum	16211	24611	0	0	9	0	0	0
Maximum	64683	116248	640	640	20	100	0	0
Average	35650	60190	13	13	13.8	14.5	0	0
Samples	57	57	57	57	57	18	18	18

Monitoring Period End Date	Total Ammonia Nitrogen, as N		pH	
	µg/l	µg/l	s.u.	s.u.
	Mon Avg	Daily Max	Minimum	Maximum
May-09	232	232	7.2	7.6
Jun-09	146	146	7.1	7.8
Jul-09	234	234	7.4	7.7
Aug-09	274	274	7.3	8.2
Sep-09	180	180	7.1	7.9
Oct-09	215	215	7.1	8.4
Nov-09	244	244	6.9	7.6
Dec-09				
Jan-10	604	604	7.4	8
Feb-10	514	514	7.4	7.7
Mar-10	0	0	7.4	7.7
Apr-10	335	335	7.3	7.8
May-10	163	163	7.2	7.6
Jun-10	119	119	7.2	7.6
Jul-10	0	0	7.1	7.6
Aug-10	109	109	7.4	7.6
Sep-10	648	648	7.2	7.5
Oct-10	109	0	7.3	7.7
Nov-10	0	0	7.2	7.7
Dec-10	0	0	7.1	7.4
Jan-11	158	0	7.2	7.4
Feb-11	115	115	7.2	7.2
Mar-11	134	134	7.2	7.5
Apr-11	186	186	7.2	7.4
May-11	201	201	7.4	7.8
Jun-11	220	220	7.3	7.5
Jul-11	144	144	7.3	8
Aug-11	253	253	7.2	7.5
Sep-11	173	173	7.7	8.5
Oct-11	368	368	7.1	8.4
Nov-11	130	130	6.5	7.6
Dec-11	115	115	7	7.4
Jan-12	106	106	7.3	7.4
Feb-12	295	295	7.1	7.5
Mar-12	515	515	7	7.4
Apr-12	513	513	7.1	7.4
May-12	316	316	7.1	7.3
Jun-12	556	556	7.1	7.2
Jul-12	235	235	7	8.3

Aug-12	183	183	7	7.4
Sep-12	198	198	6.9	7.1
Oct-12	222	222	7.1	7.4
Nov-12	233	233	6.7	8.2
Dec-12	156	156	6.6	7.4
Jan-13	88	88	6.9	7.2
Feb-13	226	226	7	7.5
Mar-13	302	302	6.7	8.9
Apr-13	870	870	6.6	8.4
May-13	0	0	6.5	7.8
Jun-13	1301	1301	6.6	6.9
Jul-13	1260	1260	6.6	6.8
Aug-13	637	637	6.6	7.4
Sep-13	804	804	7.7	8
Oct-13	690	690	7.6	7.8
Nov-13	434	434	7.5	7.9
Dec-13	358	358	7.3	7.8
Jan-14	404	404	7.4	7.9
Feb-14	522	522	7.7	8.1
2009 Permit Limits	Report	Report	6.5 s.u.	9.0 s.u.
Minimum	0	0	6.5	6.8
Maximum	1301	1301	7.7	8.9
Average	311	311	7.1	7.7
Samples	57	57	57	57

Figure 1  
Facility Location and Outfall  
Genzyme Corporation

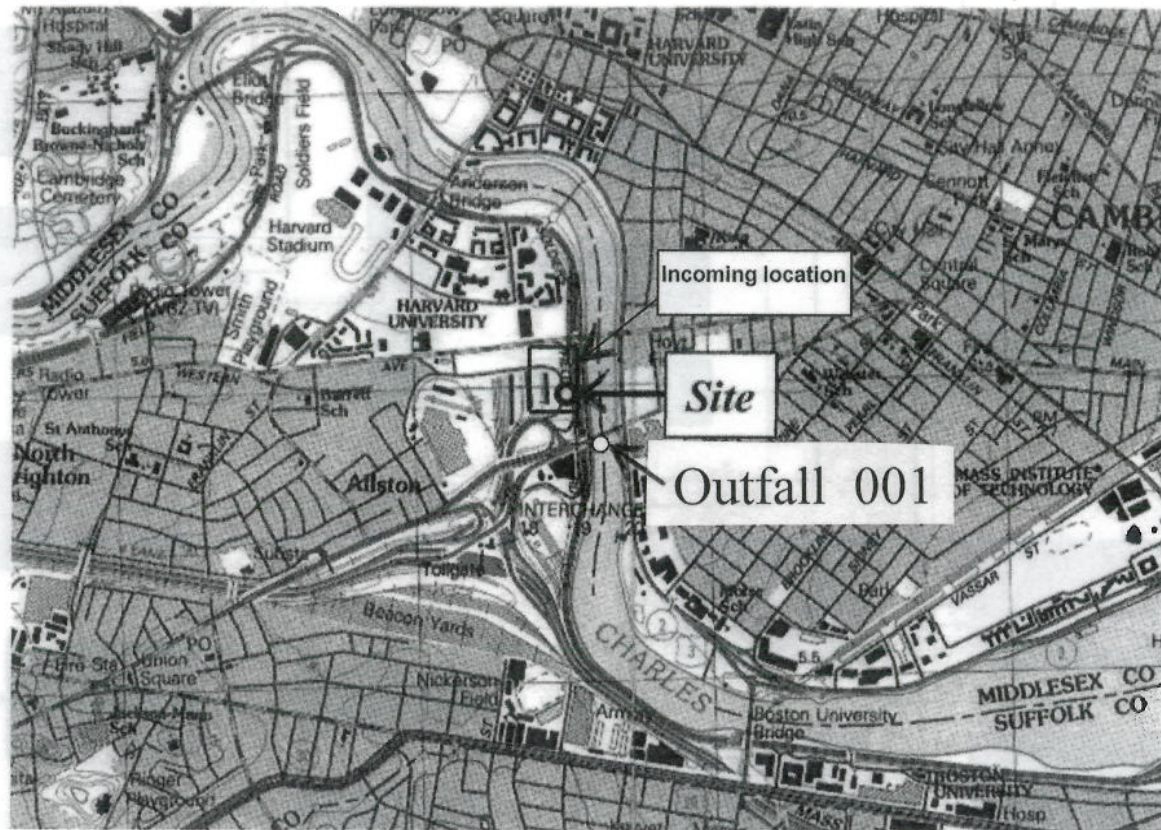

2000 0 500 1000 2000

Approximate Scale In Feet

River flow West to East and Tide Dependent

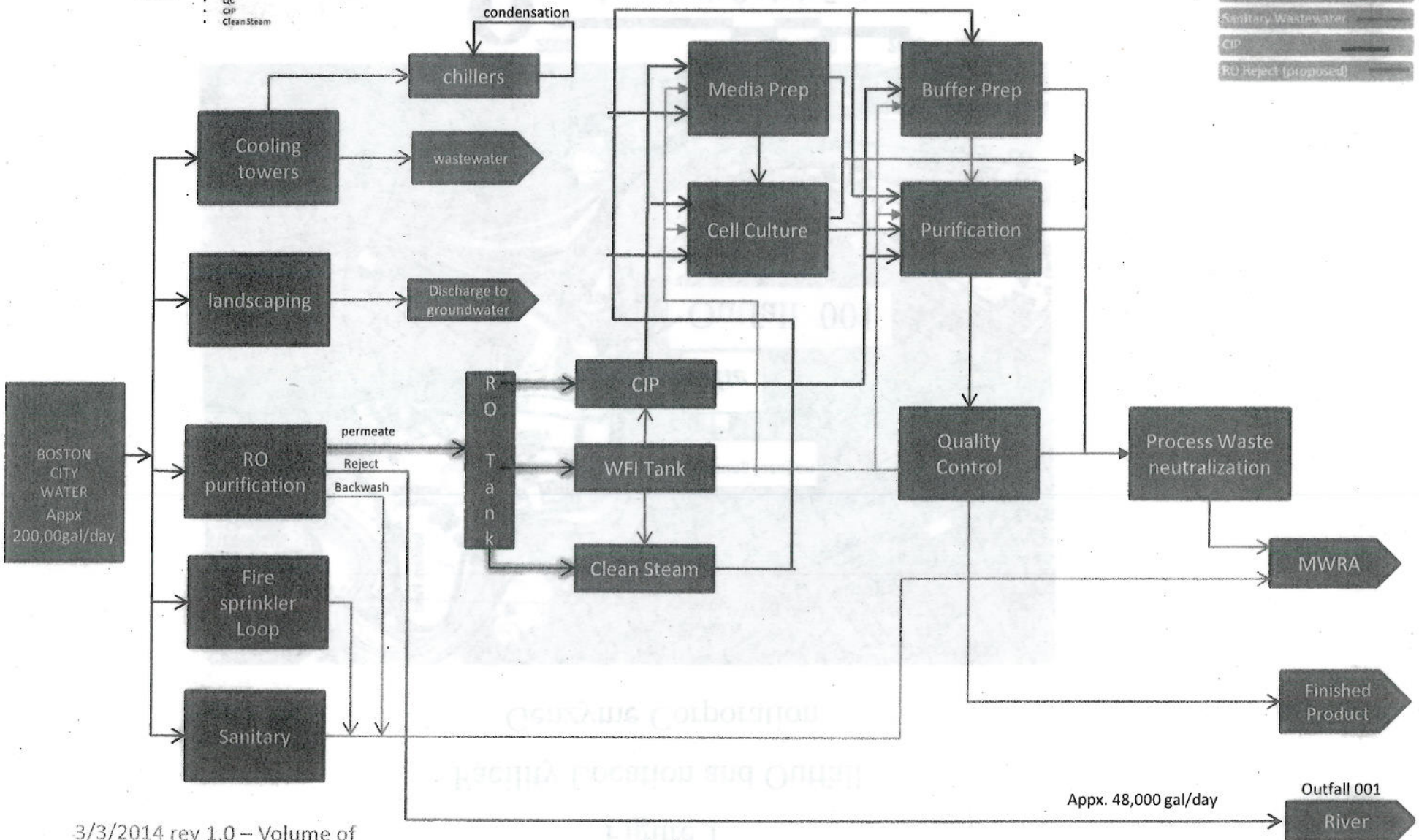

Figure 2

Water Flow Schematic  
Genzyme Corporation

Water Distributions			
RO Permeate	CIP	WFI	Clean Steam
• CIP	• Media Prep	• Media Prep	• Media Prep
• WFI	• Buffer Prep	• Buffer Prep	• Buffer Prep
	• Cell Culture	• Cell Culture	• Cell Culture
	• Purification	• Purification	• Purification
		• QC	
		• CIP	
		• Clean Steam	

City Water
WFI Water
RO permeate
WIP
Clean Steam
Process Waste
Chemical Waste
Sanitary Wastewater
CIP
RO Reject (proposed)



3/3/2014 rev 1.0 – Volume of Discharges Added – RO Reject

M.Frempong

MASSACHUSETTS DEPARTMENT OF  
ENVIRONMENTAL PROTECTION  
COMMONWEALTH OF MASSACHUSETTS  
1 WINTER STREET  
BOSTON, MASSACHUSETTS 02108

UNITED STATES ENVIRONMENTAL  
PROTECTION AGENCY  
OFFICE OF ECOSYSTEM PROTECTION  
REGION I  
BOSTON, MASSACHUSETTS 02109

JOINT PUBLIC NOTICE OF A DRAFT NATIONAL POLLUTANT DISCHARGE  
ELIMINATION SYSTEM (NPDES) PERMIT TO DISCHARGE INTO THE WATERS  
OF THE UNITED STATES UNDER SECTION 301 AND 402 OF THE CLEAN  
WATER ACT (THE "ACT"), AS AMENDED, AND REQUEST FOR STATE  
CERTIFICATION UNDER SECTION 401 OF THE ACT.

DATE OF NOTICE: February 10, 2015

PERMIT NUMBER: **MA0040291**

PUBLIC NOTICE NUMBER: MA-008-2015

NAME AND MAILING ADDRESS OF PERMITTEE:

**Genzyme Corporation  
500 Soldiers Field Road  
Allston, MA 02134**

NAME AND ADDRESS OF THE FACILITY WHERE DISCHARGE OCCURS:

**Genzyme Corporation  
500 Soldiers Field Road  
Allston, MA 02134**

RECEIVING WATER: **Charles River**  
(USGS Hydrologic Code #01090001 – Charles River Basin)

PREPARATION OF THE DRAFT PERMIT:

The U.S. Environmental Protection Agency, (EPA) and the Massachusetts Department of Environmental Protection (MassDEP) have cooperated in the development of a permit for the above identified facility. The effluent limits and permit conditions imposed have been drafted to assure that State Water Quality Standards and provisions of the Clean Water Act will be met. EPA has formally requested that the State certify this draft permit pursuant to Section 401 of the Clean Water Act and expects that the draft permit will be certified.

## INFORMATION ABOUT THE DRAFT PERMIT:

A fact sheet or a statement of basis (describing the type of facility; type and quantities of wastes; a brief summary of the basis for the draft permit conditions; and significant factual, legal and policy questions considered in preparing this draft permit) and the draft permit may be obtained at no cost at: [http://www.epa.gov/region1/npdes/draft\\_permits\\_listing\\_ma.html](http://www.epa.gov/region1/npdes/draft_permits_listing_ma.html) or by writing or calling EPA's contact person named below:

George Papadopoulos, US EPA  
5 Post Office Square  
Suite 100 (OEP 06-1)  
Boston, MA 02109-3912  
Telephone: (617) 918-1579

The administrative record containing all documents relating to this draft permit is on file and may be inspected at the EPA Boston office mentioned above between 9:00 a.m. and 5:00 p.m., Monday through Friday, except holidays.

## PUBLIC COMMENT AND REQUEST FOR PUBLIC HEARING:

All persons, including applicants, who believe any condition of this draft permit is inappropriate, must raise all issues and submit all available arguments and all supporting material for their arguments in full by March 11, 2015, to the U.S. EPA, George Papadopoulos, 5 Post Office Square, Suite 100, Mailcode OEP 06-1, Boston, Massachusetts 02109-3912. Any person, prior to such date, may submit a request in writing to EPA and the MassDEP for a public hearing to consider this draft permit. Such requests shall state the nature of the issues proposed to be raised in the hearing. A public hearing may be held after at least thirty (30) days public notice whenever the Regional Administrator finds that response to this notice indicates significant public interest. In reaching a final decision on this draft permit the Regional Administrator will respond to all significant comments and make the responses available to the public at EPA's Boston office.

## FINAL PERMIT DECISION AND APPEALS:

Following the close of the comment period, and after a public hearing, if such hearing is held, the Regional Administrator will issue a final permit decision and forward a copy of the final decision to the applicant and each person who has submitted written comments or requested notice. Within 30 days following the notice of the final permit decision any interested person may submit petition to the Environmental Appeals Board to reconsider or contest the final decision.

David Ferris, Director  
MASACHUSETTS WASTE WATER  
PROGRAM  
MASSACHUSETTS DEPARTMENT OF  
ENVIRONMENTAL PROTECTION

Ken Moraff, Director  
OFFICE OF ECOSYSTEM PROTECTION  
ENVIRONMENTAL PROTECTION  
AGENCY