

Research and Development



# Spatial Distribution and Temperature Selection of Fish Near the Thermal Outfall of a Power Plant During Fall, Winter and Spring

*from Lile Golden*  
*459-492*  
*between #459-#491*

*#774*

U. S. Environmental Protection Agency  
Region I Library  
2100-B JFK Federal Building  
Boston, MA 02203

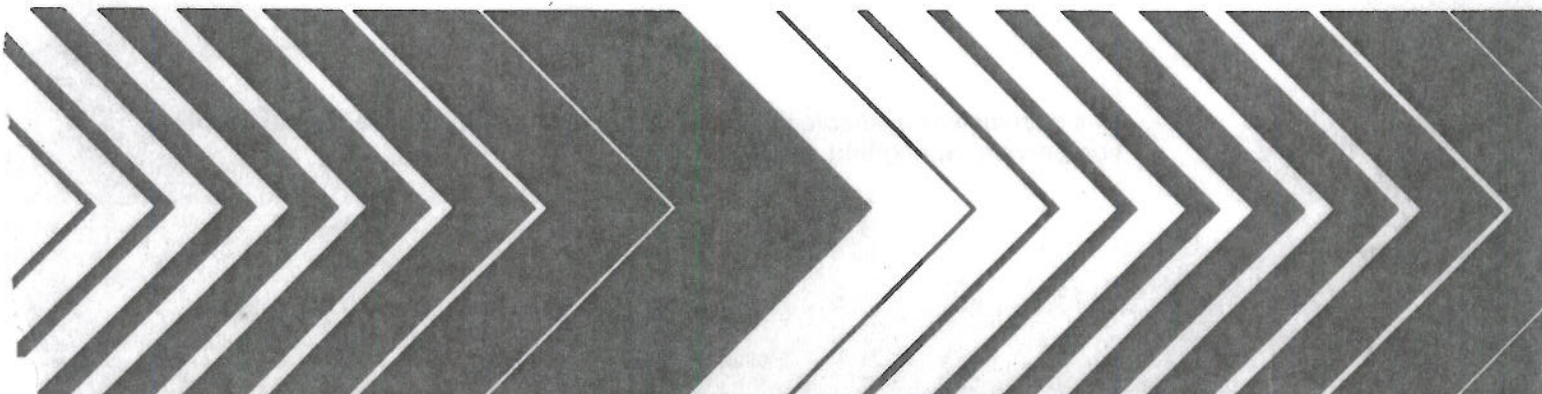

## RESEARCH REPORTING SERIES

Research reports of the Office of Research and Development, U.S. Environmental Protection Agency, have been grouped into nine series. These nine broad categories were established to facilitate further development and application of environmental technology. Elimination of traditional grouping was consciously planned to foster technology transfer and a maximum interface in related fields. The nine series are:

1. Environmental Health Effects Research
2. Environmental Protection Technology
3. Ecological Research
4. Environmental Monitoring
5. Socioeconomic Environmental Studies
6. Scientific and Technical Assessment Reports (STAR)
7. Interagency Energy-Environment Research and Development
8. "Special" Reports
9. Miscellaneous Reports

This report has been assigned to the ECOLOGICAL RESEARCH series. This series describes research on the effects of pollution on humans, plant and animal species, and materials. Problems are assessed for their long- and short-term influences. Investigations include formation, transport, and pathway studies to determine the fate of pollutants and their effects. This work provides the technical basis for setting standards to minimize undesirable changes in living organisms in the aquatic, terrestrial, and atmospheric environments.

SPATIAL DISTRIBUTION AND TEMPERATURE SELECTION OF FISH  
NEAR THE THERMAL OUTFALL OF A POWER PLANT DURING FALL, WINTER AND SPRING

by

M. J. Ross  
D. B. Siniff  
University of Minnesota  
Minneapolis, Minnesota 55455

Contract No. 68-03-2145  
Grant No. R804997010

Project Officer

J. Howard McCormick  
Environmental Research Laboratory  
Duluth, Minnesota 55804

This study was conducted in cooperation with the  
University of Minnesota, Minneapolis, Minnesota 55455.

ENVIRONMENTAL RESEARCH LABORATORY  
OFFICE OF RESEARCH AND DEVELOPMENT  
U.S. ENVIRONMENTAL PROTECTION AGENCY  
DULUTH, MINNESOTA 55804

## DISCLAIMER

This report has been reviewed by the Environmental Research Laboratory-Duluth, Duluth, Minnesota, U.S. Environmental Protection Agency, and approved for publication. Approval does not signify that the contents necessarily reflect the views and policies of the U.S. Environmental Protection Agency, nor does mention of trade names or commercial products constitute endorsement or recommendation for use.



## FOREWORD

The studies reported were initiated to determine the degree of concern that should be rendered yellow perch inhabiting an environment receiving a heated water discharge. A portion of the upper Mississippi River near Cohasset, Minnesota, receiving a heated discharge from a coal-fired power plant, was chosen for the study site. The study was initiated after completion of two laboratory studies; one determined that yellow perch required a winter chill period of a relatively long duration for successful spring spawning to take place; and another determined that the species, even in winter, preferred water temperatures well in excess of those leading to successful spring spawning.

The study site provided options between various habitats including those that would promote normal reproduction and those artificially heated such as to inhibit spawning success. The consequences of various thermal experiences for given periods were known from laboratory data. Thus, it was necessary to determine what thermal experience the fish would choose when given the options. It was further desirable to determine the area of influence and the portion of the yellow perch population affected by the introduced environmental perturbation.

Conventional sampling methods were not adequate for this project since instantaneous positioning of a fish reveals little about cumulative thermal experiences of individuals. The cumulative thermal experience is a reflection of both changes in positions of individuals and changes in water temperature gradients both away from and with reference to the heated effluent. Thus single time or widely time spaced locating of individuals was not adequate. To accomplish the goals of this research it was necessary to employ telemetry techniques that allowed continuous monitoring of movements and thermal experiences encountered during extended periods. The findings are not unexpected in retrospect, but very thought-provoking, and emphasize the importance of field validation of at least representative categories of pollution discharges into ecosystems similar to those likely to receive those discharges.

J. David Yount  
Deputy Director  
Environmental Research Laboratory - Duluth

## ABSTRACT

The movement patterns of 4 fish species: yellow perch (Perca flavescens), northern pike (Esox lucius), largemouth bass (Micropterus salmoides) and walleye (Stizostedion vitreum) were monitored by radio telemetry near the thermal discharge of a power plant ( $\Delta T$  15°C nominal). Fish movements relative to depth, temperature, center of the home range, discharge point, and release location are examined. Near thermally altered areas northern pike exhibited the greatest amount of movement followed by yellow perch, walleye and largemouth bass. Except for largemouth bass, thermal experience was found to be transitory. An overall mean winter temperature selection of 5.4°C was determined for yellow perch. While only in the thermally altered area yellow perch had a slightly higher mean thermal experience, 6.3°C. Yellow perch were not found to be attracted from the surrounding areas into the heated waters of the discharge bay during the cooler months. Not until spring was a population concentrating influence observed and that was believed due to indirect influences: more cover due to greater available light in the ice free area contributing to a higher standing stock of aquatic vegetation.

We concluded that temperature, when in concert with numerous other environmental variables, did not alter the distribution of yellow perch from that predicted on the basis of laboratory temperature preference studies. Furthermore, movement patterns of northern pike, walleye and largemouth bass were found to be relatively similar to those reported from thermally unaltered areas.

## TABLE OF CONTENTS

Foreword.....	iii
Abstract .....	iv
List of Tables.....	vii
List of Figures .....	ix
Acknowledgments .....	xi
1. Introduction .....	1
2. Conclusions .....	5
3. Recommendations .....	6
4. Study Area .....	7
5. Methods .....	10
Collecting and Tagging .....	10
Fish Transmitters .....	12
Tracking and Recording .....	15
Data Analysis: Distribution .....	16
Data Analysis: Temperature .....	17
Autumn Fish Distribution .....	18
Associated Studies .....	18
6. Results .....	19
Yellow Perch Temperature .....	19
Summary .....	23
Winter Fish Distribution .....	23
Home Range .....	23
Mobility .....	27
Temperature .....	27
Depth .....	43
Simultaneous Tracking .....	43
Summary .....	43



Autumn Distribution Results .....  
Summary.....  
  
Associated Observations .....  
Yellow Perch Length and Weight .....  
Gonadal Somatic Indices .....  
Winter Trap Netting .....  
Spawning Condition and Sex Ratios .....  
Recapture Results .....

7. Discussion.....

References .....

Appendices

A. Studies to determine the effect of radio transmitters on yellow perch and largemouth bass.....  
B. Temperature transmitter design and development.....  
C. Automatic receiving and recording system.....  
D. Fish tagged, tracking period and number of observations .....

E. Accuracy of locating radio tagged fish by triangulation .....

LIST OF TABLES

Number	Page
1. Fish radio tag specifications.....	14
2. Overall yellow perch winter temperature selection (degrees celsius).....	20
3. Overall yellow perch winter temperature selection grouped at the P=0.05 level by analysis of variance.....	21
4. Yellow perch winter temperature selection in thermally altered areas.....	24
5. Yellow perch winter temperature selection in thermally altered area grouped at the P=0.05 level by analysis of variance.....	25
6. Diel winter perch mean temperatures.....	26
7. Adjusted minimum area winter home ranges.....	32
8. Fish mobility as mean distance moved per day and mean distance moved from center of home range and release site .....	33
9. Mean fish distance from discharge point .....	37
10. Fish movement with respect to thermally altered and unaltered areas.....	40
11. Amount of time fish were located in the discharge bay as a percent of the entire individual tracking periods ...	42
12. Depth selection by fish in the discharge area.....	46
13. A summary of results for two periods when fish were tracked concurrently.....	47
14. Autumn yellow perch movement .....	51
15. Yellow perch standard length and weight observations, April 30, to May 5, 1975.....	57



C range under natural conditions. The work of Barans and Tubb (1973) using yellow perch acclimated to seasonal ambient temperatures of Lake Erie concluded that selected temperatures changed from one time of the year to the next. They reported fall, winter, and spring selected temperature ranges for adult yellow perch of; 13-21°C, 12-16°C, and 10-14°C respectively. Temperature preference studies performed by McCauley (1977) using a horizontal gradient tank found adult yellow perch temperature preference changed with acclimation. At 5°C acclimation the selected temperatures ranged from 12.3 to 23.8°C while at 20°C acclimation selected temperatures ranged from 16.1 - 24.2°C. These values were not found to change seasonally, and all were well above the maximum temperatures available under natural winter conditions throughout the species range.

With the introduction of a thermal discharge into an environment, seasonal ambient water temperature options previously unavailable to the indigenous fishes become available. The subsequent question which arises is then, what will be the responses of fishes to these new options? These studies have concentrated on examining responses of yellow perch to a thermal discharge into an upper Mississippi River ecosystem during the cooler portions of the year, those seasons when heated waters are most attractive are when least field work has traditionally been conducted. Concern for the reproductive success of yellow perch when provided with the option of heated water during the winter months stems from research conducted at the EPA Environmental Research Laboratory - Duluth, where it was learned that maximum reproductive success of the species followed over wintering at temperatures of 4°C for 185 days and that little or no success resulted when over winter was at 10°C (Jones et al. 1977). The significance of this seemed accentuated when it is considered that the distribution of the species is associated with that portion of the country where ice cover is expected during the winter months. With this fact in mind it becomes apparent that the species is adapted to winter temperatures not greater than 4°C, the warmest possible water under ice cover. The concern for the reproductive success of the species was further accentuated when laboratory gradient tank studies revealed that adult yellow perch, after acclimation to 5°C, have preferenda in excess of 10°C (McCauly 1977). Under natural conditions, this would not pose a concern as there is no heated water available. However, when a heated water supply is provided the question arises as to what will be the response of the fish to a choice between natural 4°C maximum temperature or some other temperature more nearly approaching their winter preferendum.

The next question is: if fish are attracted to the unseasonally elevated temperatures, what is the area of the thermal influence, and what kind of population concentrating effect can be expected? Or in other words, what portion of the population in the vicinity of the heated discharge can be expected to be affected by that discharge? This potential concentrating effect has, in addition to the potential spawning inhibition, the potential of concentrating a major portion of the endemic perch spawning stock in a relatively small area. Also, the area is



particularly vulnerable to chemical alteration from condenser and cooling tower anti-fouling agents as well as to cold shock should the artificial heat source be abruptly shut down.

Conventional fisheries methodology was not well suited to answering these questions since it was not only necessary to know that a fish was present at a given location in respect to the heated discharge but also to know where it had been previously and where it would be at subsequent times. Biotelemetry is uniquely suited to such problem solving and was employed in these studies. Short exposures to elevated temperatures of the magnitude involved at this site would not have adverse effects; it is only the accumulated thermal exposure that would inhibit reproductive potential. The study of population concentrating effects is also facilitated by being able to follow the movements of individual fish into the heated water zone or out again.

Biotelemetry methods have proven successful in tracking several free-ranging species of fish including largemouth bass, Micropterus salmoides, and rainbow trout, Salmo gairdneri, (Winter 1976). Also, Cluggston (1973) and Warden and Lorio (1975) have used biotelemetry methods to observe the behavior of largemouth bass relative to environmental alterations.

The major objectives of our research were:

- Determine the winter temperature selection of adult yellow perch in the vicinity of a thermal effluent.
- Determine the distribution and movements of fishes, particularly yellow perch, relative to a thermal discharge during the fall, winter and spring.
- Determine population concentrating influences of a thermal discharge on yellow perch during the season when discharge temperatures approached laboratory determined preferenda more closely than seasonal ambient water temperatures.

This study was accomplished with three subprojects. First, fish were equipped with radio transmitters and tracked in the thermal discharge area to determine winter distribution and associated temperatures. During this phase of the study, temperature-sensitive transmitters and an automatic recording system were put into operation. Secondly, fish from outside of the discharge area were equipped with radio transmitters and tracked in an attempt to more fully explain distribution and observe population concentrating influences of the discharge. The third subproject was a series of associated observations made in conjunction with the above radio tracking studies, in order to substantiate our telemetry inferences. These include mark-recapture operations, comparative survey information, catch per unit effort, sex ratio, spawning condition, and gonadalsomatic indices of yellow perch within and

## SECTION 5

### METHODS

#### COLLECTING AND TAGGING

Fish for radio tagging were collected principally with five single pot trap nets set between 1 m and 3 m deep. Nets were inspected every morning during trapping periods, weather permitting. All fish were removed and the numbers of each species recorded for survey information. Fish retained for tagging were transported in tubs via boat to a holding tank. Occasionally fish were provided by anglers, commercial fishermen, Wapora Inc. trap nets and Minnesota Power and Light Company electrofishing operations.

Fish to be tagged were held in a 600 liter stainless steel tank equipped with a heater and aerator. We attempted to maintain temperatures in the holding tank approximately the same as the temperature of the water where fish were collected by utilizing various combinations of insulation, heating, aeration, and freshwater flow from the Mississippi River.

Prior to the tagging operation fish were weighed, measured, sexed, and a scale sample taken. For tagging, fish were placed in a trough and kept moist by dripping water from a wet towel. Radio tags were applied externally by a subdorsal fin mount (Fig. 2). Using either a hypodermic needle or a surgical needle two teflon-coated wires protruding from the transmitter were threaded through the supporting tissue between pterygiophores immediately ventral from the dorsal fin (Fig. 2a). A plastic plate was installed on the opposite side of the fish and the attachment wires were tied and the excess clipped off (Fig. 2b). Total time for the tagging operation averaged 3.5 minutes. At no time, however, was a fish held out of water more than 2 minutes before being submerged for a time and the operation continued to completion. Fish tagged during the fall and spring months were sedated with Tricaine Methanesulfonate (MS-222) and given a static one hour treatment with Aureomyein (20 ppm). Fish tagged during winter months were not treated chemically.

Fish generally acclimated to the tag within 0 to 25 minutes i.e., they regained equilibrium and swam normally in the holding tank. Appendix A discusses the bio-effects of external tags on small fish. Following an acclimation and observation period of two to four hours, radio tagged fish were released at their respective trapping sites.



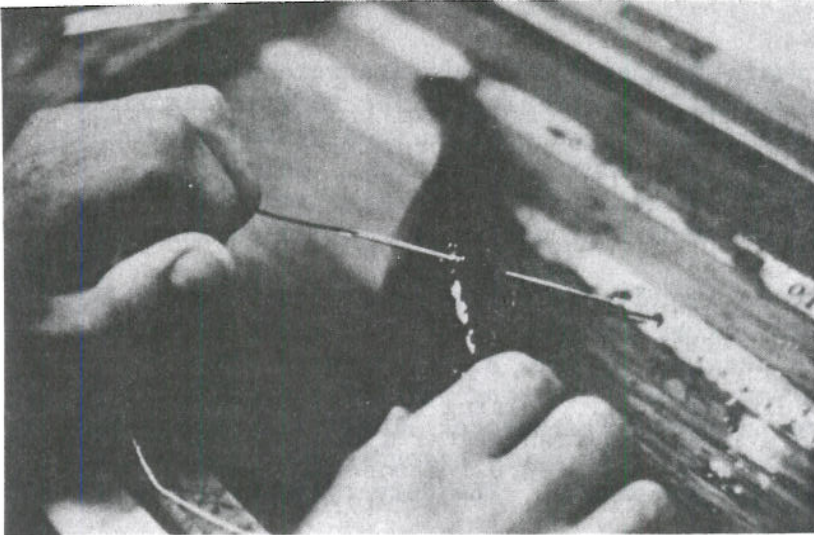

a) Feeding attachment wire through muscle tissue.

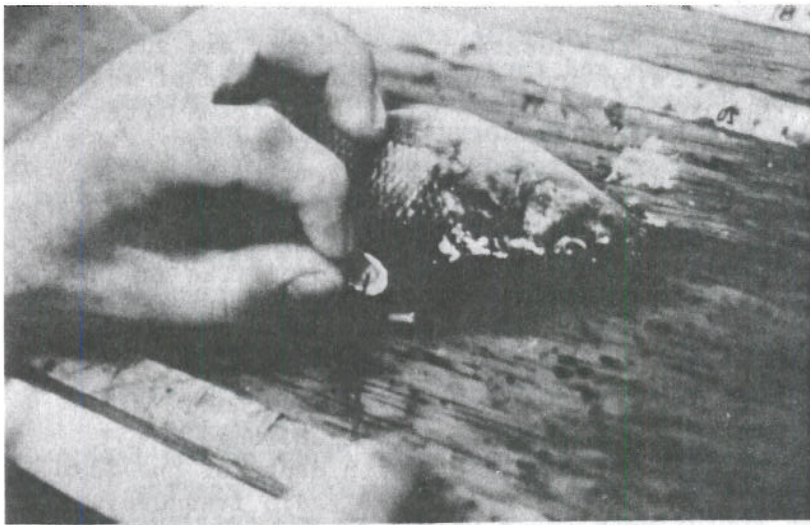

b) Attaching plastic backing plate.

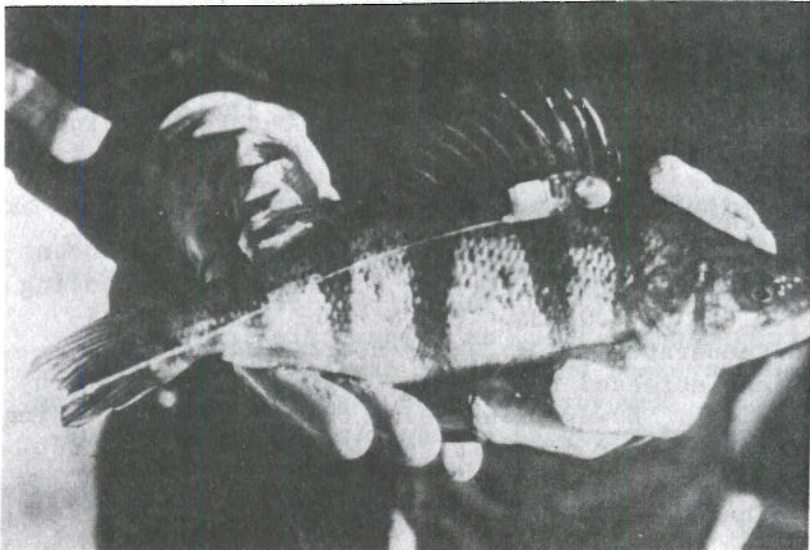

c) Sub dorsal mount.

Figure 2. Attaching radio transmitter.



## FISH TRANSMITTERS

Two types of 53 MHz radio frequency transmitters were used during this study. Initially a transmitter circuit similar to that described by Cochran and Lord (1963) was modified and miniaturized by the University of Minnesota's Cedar Creek Bioelectronics Laboratory. Secondly, a temperature-sensing transmitter was designed, miniaturized, field tested, and drift tested by this laboratory for use in the yellow perch studies.

The location transmitter circuit and component arrangement are shown in Figure 3. The original design was for a continuous wave ("whistling") signal. Capacitor C<sub>3</sub> and resistor R<sub>2</sub> were added to cause the transmitter to emit a pulsed signal. Pulsing signals reduced power consumption and therefore increased transmitter life. The pulse width (on time) of our transmitters was 0.02-0.025 seconds and the pulse rate was between 60 and 120 pulses per minute. The duty cycle or ratio of on time to total time was 3% + 1%.

Technical specifications for the location transmitter are summarized in Table 1. Transmitter life, size and range are parameters of most concern to biologists. The theoretical life based on a transmitter current drain of 0.3 - 0.4 m.a. with a Mallory 675 battery was approximately 30 days. Actual life averaged 33 days. It should be noted, however, that the average actual life was biased to the low range as during certain tracking periods we could not always determine if the transmitter had stopped because the battery expired or if the fish had simply moved out of range or was captured and the tag not returned. Size of perch location transmitters averaged 3.3 cm long, 1.3 cm wide, and 0.6 cm deep. The final weight of the transmitter on the fish, i.e., components plus encapsulating material minus excess attachment wires minus water volume displaced, averaged 3.5 g. Maximum range was difficult to determine exactly as range varied with depth of the fish, meteorological conditions, water conductivity, and radio frequency interference. However an approximate range of 0.7 km was determined.

For the temperature transmitter we added a thermistor and control circuitry to a location transmitter, resulting in a pulse rate that was temperature-dependent. Pulse width remained constant but the spacing between pulses varied with temperature.

Table 1 summarizes technical specifications of the temperature transmitter. Theoretically life and range parameters should have been similar to those of the location transmitter as the temperature-sensing circuitry only consumed 0.005 to 0.01 ma. The current drain of the entire unit varied with temperature; i.e., as temperature increased, pulse rate increased which increased the current drain. Current drains of 0.3 to 0.7 ma were typical. However, we found that increased loading of the transmitter antenna in water caused a reduction in power output. We needed to lower base resistor R<sub>6</sub> from 100 k ohms to 47 k ohms to increase power output. Therefore, early models with the 100 k ohm R<sub>6</sub> had greatly extended life of 100 - 120 days, but a range of only



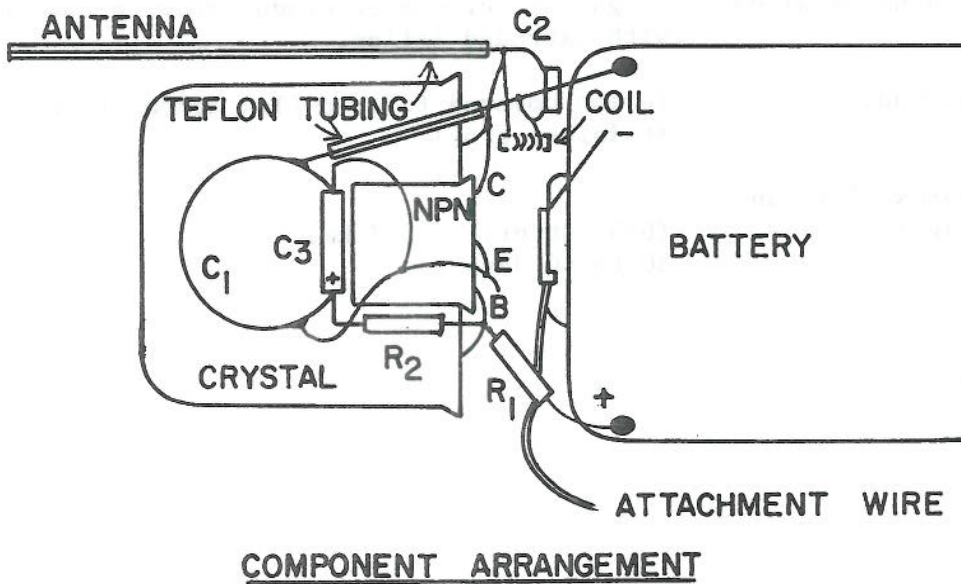
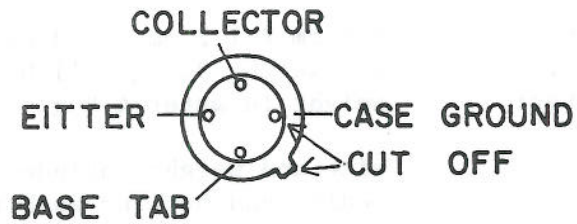
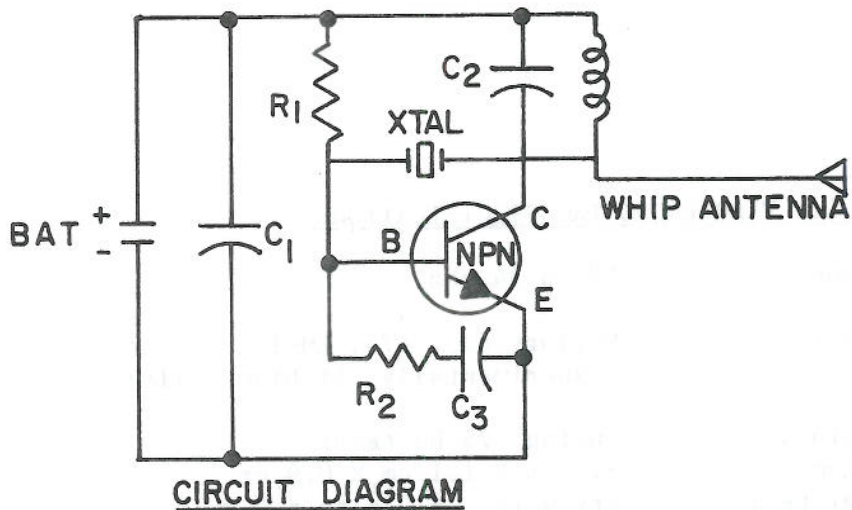

Figure 3. Transmitter circuit diagram and component arrangement.

Table 1. FISH RADIO TAG SPECIFICATIONS

Frequency:	53 to 54 mhz.
Battery:	Mallory 625, 675, RM-1 (Experimentally, lithium cells)
Dimensions, Location Transmitter:	(using 675 battery) 3.3 cm X 1.1 cm X 0.9 cm dry weight 6.0 g to 6.5 g weight in water 3.5 g
Dimensions, Temperature Transmitter:	4.6 cm X 1.2 cm X 0.9 cm dry weight 9.5 g - 11.0 g weight in water 4.9 g
	size and weight include transmitter potted and sealed and backing washer.
Potting Compound:	Scotch Cast epoxy sealed with a final coat of clear fingernail polish.
Backing washer:	1.6 mm low density polyethylene cut and ground to proper size and shape.
Attachment wires:	24 ga. silver-copper conductor wire covered with extruded teflon.
Antenna:	Teflon covered twist-o-flex dental type stainless steel.
Approx. life and range:	(675 battery) - 0.7 km. 30 to 40 days

approximately 150 meters. Later model transmitters had life and range parameters similar to location transmitters. With the added circuitry, perch temperature transmitters were slightly larger than location transmitters. Size of perch temperature transmitters averaged 4.6 cm long, 1.2 cm wide and 0.9 cm deep. The final weight in water of the temperature transmitter averaged 4.9 g. Appendix B elaborates on the design and development of the temperature transmitter circuit.

After construction a numbered identifier label with tag return information was taped to the crystal. Transmitters were then encapsulated in Scotch cast #5 electrical resin (3M Company). This compound made the units watertight and supported all components. After the resin hardened the excess was ground off and the transmitter package streamlined with a electric grinder. After allowing the tags to stabilize 24 hours, temperature transmitters were calibrated in agitated water from 0 - 20°C. Immediately prior to fish tagging, the final battery connection was completed and a coat of quick-drying final sealant was painted on the entire transmitter. Marine epoxy was used initially as a final sealant; however, it tended to become cloudy with age. Clear fingernail polish was found to dry faster and remain transparent, thus, tags could be more easily identified.

#### TRACKING AND RECORDING

Fish location and temperature information were collected using 53 MHz radio frequency receivers in conjunction with yagi and loop antennas. An important feature of radio frequency telemetry is the flexibility available for data collection. Locations were obtained by triangulation from shore towers and mobile tracking equipment. Temperature information was collected at a remote recording station, and manually with a stop watch.

Fifty three MHz receivers used for location and manual temperature information were constructed by the Cedar Creek Bioelectronic Laboratory. These receivers were capable of distinguishing 100 different transmitters (fish) spaced 10 KHz apart. Animals were located by triangulating from three, 4 element yagi antennas mounted on 7 m semi-permanent shore towers around the discharge bay as described by Winter et al. (1978). Shore towers were calibrated by placing transmitters at known locations and taking bearings to these locations. Correction factors were then added or subtracted to fish bearings. When fish left the immediate discharge area, they were located with respect to landmarks by handheld and airplane mounted loop antennas and truck and boat mounted yagi antennas.

We usually attempted to locate all fish at least once a day. Priority was given to those individuals in the immediate discharge area; often these fish were located 3 to 4 times a day. On several occasions, 'round-the-clock' tracking at 2 to 3 hour intervals was attempted; however, sporadic radio frequency interference limited the success of these attempts. When fish were located their positions were noted in reference to gridded maps of the area.



Fish temperature data were collected in 2 ways. Temperature transmitter pulse rates were monitored manually with a stopwatch when location data were being obtained. However, the principal source of fish temperature information was an automatic monitoring and recording system designed for this project. The system consisted of a 53 MHz channel-scanning receiver coupled to a pulse rate decoder and strip chart recorder. The equipment was housed in a remote recording shack near the shore of the discharge bay. We found that a near-shore location and low 3 m antennas optimized the signal to interference ratio. The recording system is more fully described in Appendix C. The entire receiving-recording system was powered by a 12 v automobile battery. Generally we adjusted the receiver scanning rate to monitor each temperature transmitter (fish) for a period of 4 minutes once every 64 minutes. In conjunction with the scanning system, a second continuous receiving-recording system was installed. This system monitored temperature for a selected individual continuously for 24 hour periods.

#### DATA ANALYSIS: DISTRIBUTION

Fish located by triangulation were plotted on grid maps of Cohasset area. Winter and spring telemetry data were analyzed by individual fish with existing University of Minnesota computer programs for home range, distance moved from center of home range, release site and between consecutive sites, distance from discharge point and changes in this last parameter with changing plant operations.

Home range was defined by Hayne (1949) as the area utilized by an animal in the course of normal movements excluding migrations and occasional wanderings. Several methods for determining home range areas have been proposed including home range rectangle, summation of grid squares and minimum area polygon. Our analysis was based on an adjusted minimum area polygon method as determined by computer programs described by Siniff and Tester (1965). This procedure was found to be most compatible with non-automatic telemetry operations. To determine home range with the minimum area polygon, all individual fish locations were plotted and the area of the smallest convex polygon enclosing these fixes was computed (Odum and Kuenzler 1955). This minimum area was then adjusted by subtracting any portions that occurred on land due to shoreline irregularities. With sufficient location data, adjusted minimum area approached the maximum area utilized by an animal.

Distance analysis for species mobility was accomplished in 2 manners; first, by defining a fixed point i.e., discharge point, release site etc. and entering this point with all locations for an individual fish on a 'fixed point problem' computer program. Secondly, the distance between consecutive locations was determined by entering all individual fish locations on a 'moving point' computer program. Only those fish with a minimum of 2 days between fixes while they were in the discharge area were analyzed with this method. The mean distance moved per day was then calculated as the total distance moved between fixes divided the number of days an individual was tracked.



All home range and mobility results were obtained by calculating a mean for each individual under consideration and then averaging these means for an overall species mean. Fish considered in this analysis were those fish maintaining a winter home range at least partially within the discharge area.

Discharge area temperatures were obtained with a Yellow Springs electrical resistance type thermometer. The discharge point and 3 transects with 5 equidistant stations per transect were monitored at 0.5 m intervals from surface to bottom on a weekly basis. Winter isotherm maps were constructed from these data for the upper 1.5 m of the discharge bay.

Winter distribution with respect to temperature was analyzed for movement between the discharge bay and thermally unaltered areas by plotting consecutive fish locations on a map of mean winter isotherms. This information was divided into 2 different types of movement. First, movement between the thermal discharge bay and unaltered areas when individuals were either maintaining a home range at least partially within the thermally affected areas or returned at a later date to the discharge area were termed 'crossings'. Secondly, movements from the discharge bay to unaltered areas, when the fish did not return to the discharge bay were termed 'dispersals'.

Depth selection was determined by overlaying a transparent bathymetric map of the discharge area on individual fish location co-ordinates.

#### DATA ANALYSIS: TEMPERATURE

Recording tapes were read hourly and winter temperature data were analyzed to the nearest 0.1°C. Temperatures collected manually served to augment and verify those recorded automatically. We also attempted to monitor fish that had moved out of recording range on a daily basis. Yellow perch winter temperature data were analyzed in several manners with standard (SPSS) statistical programs. First, all winter temperature data were lumped to obtain an overall group mean regardless of fish location. This method ignores the fact that several fish transmitters did not record well due to limited ranges; consequently, these individuals have a limited effect on the mean. Perch such as 1837, 1838 and 1842 that recorded for extended periods contribute proportionately more to the lumped mean. Therefore, a second method was used to determine overall perch winter mean temperature selection. Individual mean temperatures were calculated for fish with more than 20 observations. These means were then averaged so that each individual contributed equally to the overall mean.

To determine mean winter temperature selection when perch were in thermally altered waters, all temperature data greater than 1°C were analyzed with the same 2 methods as presented above.



Diel winter temperature selection was determined by analyzing mean diurnal and nocturnal temperatures for those perch with more than 20 observations in each period. This analysis was performed on both overall data and discharge area data.

#### AUTUMN FISH DISTRIBUTION

Autumn fish distribution was determined by plotting individual fish locations on gridded maps with respect to average fall isotherms.

#### ASSOCIATED STUDIES

Several other studies were carried out in conjunction with our perch telemetry operations. The purpose of these observations was to collect data in order to more fully understand the impact of the thermal discharge on the fish community and correlate it to our perch telemetry observations.

Largemouth bass, northern pike and walleye were also equipped with radio transmitters. Transmitter size and configuration varied. Several models were used including a lithium cell powered unit. Capture, transport, tagging, tracking, recording and data analysis methods for these fish were essentially identical to those used for yellow perch. Yellow perch, largemouth bass, northern pike and walleye not utilized for telemetry purposes were treated in one of two manners. First, length and weight measurements were taken, and then fish were tagged with numbered Atkins tags for mark-recapture information. These fish were handled similarly to telemetry fish; however, tagging time was reduced and because of the larger numbers involved, individuals were anesthetized with MS-222. Finally, samples of yellow perch were preserved for later anatomical observations. Laboratory studies on preserved specimens involved comparing the gonado-somatic indices of yellow perch collected in the discharge bay with those of perch collected during the same time period from unaltered waters. Gonado-somatic indices were obtained by weighing individual fish then excising and weighing gonads. The index is the ratio of gonad weight to whole body weight expressed as a percent. Survey information recorded each time nets were pulled included net location and numbers of each species. As spawning season approached, yellow perch sex ratios and spawning condition were also noted.

## SECTION 6

### RESULTS

During the autumn, winter and early spring of 1975 and 1976, 116 yellow perch, 13 walleyes, 8 northern pike and 2 largemouth bass were equipped with radio frequency transmitters. Winter and early spring fishes from the discharge area were monitored for comparative distribution relative to the thermal plume. Included in this group were 24 perch, 2 walleye and 1 northern pike equipped with temperature sensing transmitters. Autumn fishes were captured, tagged and released outside of the discharge area to determine attraction, if any, that the heated area had for fish that came under its influence. Attraction was suspected since discharge temperatures were closer to the reported temperature preference of yellow perch at a time when normal seasonal water temperatures were declining. Tables 1 to 4 in Appendix D summarize data concerning numbers of fish, period of observation and quantity of information collected.

#### YELLOW PERCH TEMPERATURE RESULTS

Analysis of yellow perch winter temperature distribution data indicated a high degree of variability between individuals and no significant diel difference within individuals. Table 2 presents overall perch winter temperature distribution data. Mean temperature selection ranged from 1.1°C to 9.2°C for 10 individuals. Analysis of variance indicated a significant difference among average temperatures for individual perch ( $p < 0.05$ ). Table 3 presents the results of 3 different multiple comparison tests to separate significant groups of means. The least significant difference procedure was considered a liberal test and indicated that the 10 perch winter temperature means with 20 or more observations per individual could be separated into 7 different groups. The more conservative Student-Newman-Kuels' procedure also separated the individual means into 7 groups, while the Scheffe procedure, a very conservative test, divided the individual overall winter means into 6 subsets with a maximum of 4 fish in a group.

The perch overall winter temperature frequency distribution was bimodal with peaks at 0°C and 8°C (Figure 4). The lower mode reflected the large number of temperature observations on fish that moved into unaltered waters. The 8°C mode represented the most commonly encountered temperature only while yellow perch were in the discharge affected areas. The mean overall temperature selection for yellow perch determined by averaging individual means was found to be 5.4°C.

Table 2. OVERALL YELLOW PERCH WINTER TEMPERATURE SELECTION (°C)

Fish Id. No.	No. of Observations	Mean	Standard Deviation	Minimum	Maximum	95% Confidence Interval
1833	97	3.4	2.6	0	9.3	2.9 - 4.0
1834	160	5.0	3.0	0	12.8	4.5 - 5.5
1836	23	5.0	3.0	0	8.6	3.8 - 6.4
1837	1110	7.4	2.2	0	13.0	7.3 - 7.5
1838	342	4.8	2.9	0	12.9	4.5 - 5.1
1842	353	6.6	2.6	0	14.4	6.3 - 6.9
1843	92	1.1	1.8	0	10.1	0.7 - 1.5
1844	38	2.5	2.5	0	8.8	1.6 - 3.3
1847	29	9.2	4.3	0	14.6	7.6 - 10.9
1848	121	8.5	2.6	0	14.1	8.1 - 9.0

Total 2365

Mean by averaging individual means: 5.4° C

Mean by grouped data: 6.3° C



A large number of winter perch temperature observations were collected from fish outside of the discharge area. Therefore, the overall winter temperature data did not reflect the temperature selection of perch located only in the discharge bay since every fish resided in unaltered waters at least briefly, as noted by a minimum temperature of 0°C (Table 2). Winter mean temperature selection of yellow perch confined to discharge affected areas was obtained by analyzing temperatures greater than 1°C, thus eliminating data from outside of the thermal plume.

Table 4 presents temperatures selected by yellow perch while in the discharge area. Variability among individual perch remained substantial. The multiple comparison test using the 'Scheffe' procedure separated the 10 individuals into 5 significantly ( $P < 0.05$ ) different subsets (Table 5). The mean temperature selection for yellow perch while in the discharge affected areas only, as determined by averaging individual means, was 6.3°C.

Because of the high degree of temperature variability among the individual perch, winter diel temperature selection was examined on an individual basis. Diurnal and nocturnal temperature data were analyzed for all data and for the discharge area observations. Results are presented in Table 6. A t-test on individual perch winter day and night mean temperatures indicated no significant ( $p < 0.05$ ) difference. However, when the data were analyzed for perch only in discharge areas, 2 of 6 individuals preferred significantly warmer areas during the day but the diurnal means were only 0.7°C and 0.6°C higher for the 2 significant individuals.

### Summary

A high degree of variability was detected among individual perch with respect to temperature selection. In general yellow perch selected relatively cool winter temperatures from the 0°C to 15°C gradient available to them. An overall winter mean of 5.4°C was found for all data with a mean of 6.3°C observed for fish in discharge affected areas only. Yellow perch varied slightly but not significantly, with respect to diel temperature selection.

## WINTER DISTRIBUTION RESULTS

### Home Range

A comparative analysis of home range and movement data for yellow perch, northern pike, walleye and largemouth bass indicated interspecific distribution differences with respect to biotic and physical factors. By comparing home range size and utilization, and location points with respect to temperature, depth, release site and center of home range a description of the respective winter distribution of the 4 species was made.

Table 4. YELLOW PERCH WINTER TEMPERATURE SELECTION (°C) IN THERMALLY ALTERED AREAS

<u>Fish Id. No.</u>	<u>No. of Observations</u>	<u>Mean</u>	<u>Standard Deviation</u>	<u>Minimum</u>	<u>Maximum</u>	<u>95% Confidence Interval</u>
1833	74	4.5	2.0	1.1	9.3	4.0 - 5.0
1834	130	6.2	2.0	3.9	12.8	5.8 - 6.5
1836	18	6.5	1.4	4.1	8.6	5.7 - 6.5
1837	1096	7.5	2.0	1.2	13.0	7.4 - 7.6
1838	274	5.9	1.9	1.1	12.9	5.7 - 6.2
1842	343	6.8	2.4	1.4	14.4	6.5 - 7.1
1843	35	2.8	1.9	1.2	10.1	2.1 - 3.4
1844	28	3.2	2.5	1.2	8.8	2.3 - 4.2
1847	75	10.7	2.4	6.9	14.6	9.7 - 11.7

Total 2143

Mean by averaging individual means: 6.3

Mean by grouped data: 7.0



Table 5. YELLOW PERCH WINTER TEMPERATURE SELECTION IN THERMALLY ALTERED AREA GROUPED AT THE P = 0.05 LEVEL BY ANALYSIS OF VARIANCE

Scheffe' Procedure		
<u>Subset No.</u>	<u>Fish Id. No.</u>	<u>Mean Temp. (°C)</u>
1	1843	2.8
	1844	3.2
	1833	4.5
2	1833	4.5
	1838	5.9
	1834	6.2
	1836	6.5
3	1834	6.2
	1836	6.5
	1842	6.8
4	1836	6.5
	1842	6.8
	1837	7.5
	1848	8.6
5	1847	10.6

Table 6. DIEL WINTER PERCH MEAN TEMPERATURES (°C)

Fish Id.No.	Overall			In Discharge			Calculated Test Statistic
	Diurnal Mean	Nocturnal Mean	Calculated Test Statistic	Fish Id.No.	Diurnal Mean	Nocturnal Mean	
1833	3.3	3.8	0.3	1833	4.6	4.3	0.8
1834	4.2	6.1	1.4	1834	6.0	6.3	0.9
1837	7.4	7.4	0.0	1837	7.6	7.4	0.9
1838	4.7	4.8	0.0	1838	6.3	5.6	3.1*
1842	6.7	6.5	0.1	1842	7.1	6.5	2.3*
1843	1.5	0.3	0.7				
1848	8.1	8.8	0.3	1848	8.1	8.9	1.89

\* Critical "t-test" statistic of 1.98 has been exceeded at P = 0.05.

Figures 5 to 12 illustrate examples of consecutive locations and home ranges for yellow perch, northern pike, largemouth bass and walleye in the vicinity of the thermal discharge. Table 7 presents home range information. Northern pike had the largest mean winter home ranges (18.7 ha) followed respectively by yellow perch (10.6 ha), largemouth bass (3.7 ha) and walleye (2.2 ha). However, there was a good deal of variability within each group and the number of instrumented individuals was large only for perch.

### Mobility

Indices of mobility were determined by considering the distribution of distances between locations and release site, locations and geometric center of the home range, and distance between consecutive fixes (Table 8). Northern pike exhibited the greatest mobility with respect to all 3 parameters. They moved at a daily rate more than double that of bass and walleye. Northern pike and yellow perch moved at a more rapid daily rate and substantially further from the release site and geometric center of their home ranges than the walleye or bass. Figure 13 presents distance from geometric center of home range data at 50 m intervals. Ninety percent of the walleye locations were within 100 m of the geometric center of the home range. Localized movement was also apparent from the largemouth bass frequency distribution. Over 50% of both northern pike and yellow perch locations were further than 100 m from the home range's geometric center.

### Temperature

When individual fish locations were mapped over average winter isotherms in the upper 1.5 m of the discharge bay (Figures 14 to 17), largemouth bass were found in the warmest areas. Yellow perch were generally located in intermediate areas and northern pike moved across all discharge affected areas. Mean distance from discharge was computed for each species (Table 9) and was as follows: largemouth bass, 322 m; perch, 411 m; and northern pike, 411 m. Mean walleye distance for one individual was 404 m; however, a high percentage of these locations were in the center, deeper area of the discharge bay. These areas were considerably cooler than the upper 1.5 m (Figure 18).

It seemed that variations in power plant operations would cause changes in thermal discharge temperature which could result in changes in fish distribution. Individuals could have maintained a constant temperature by moving closer to or further away from the discharge point depending on the type and magnitude of power plant alteration. Distance from individual perch locations to the discharge point were determined for 3 discharge temperatures: 5°-9°C, 10°C-13°C and 14°-18°C. These temperature classes roughly corresponded to 1 unit operating, both units operating less than full capacity and both units operating full capacity respectively. Limited location data were available because when temperature transect data were being collected fish tracking data were not taken. However, 36 perch locations which



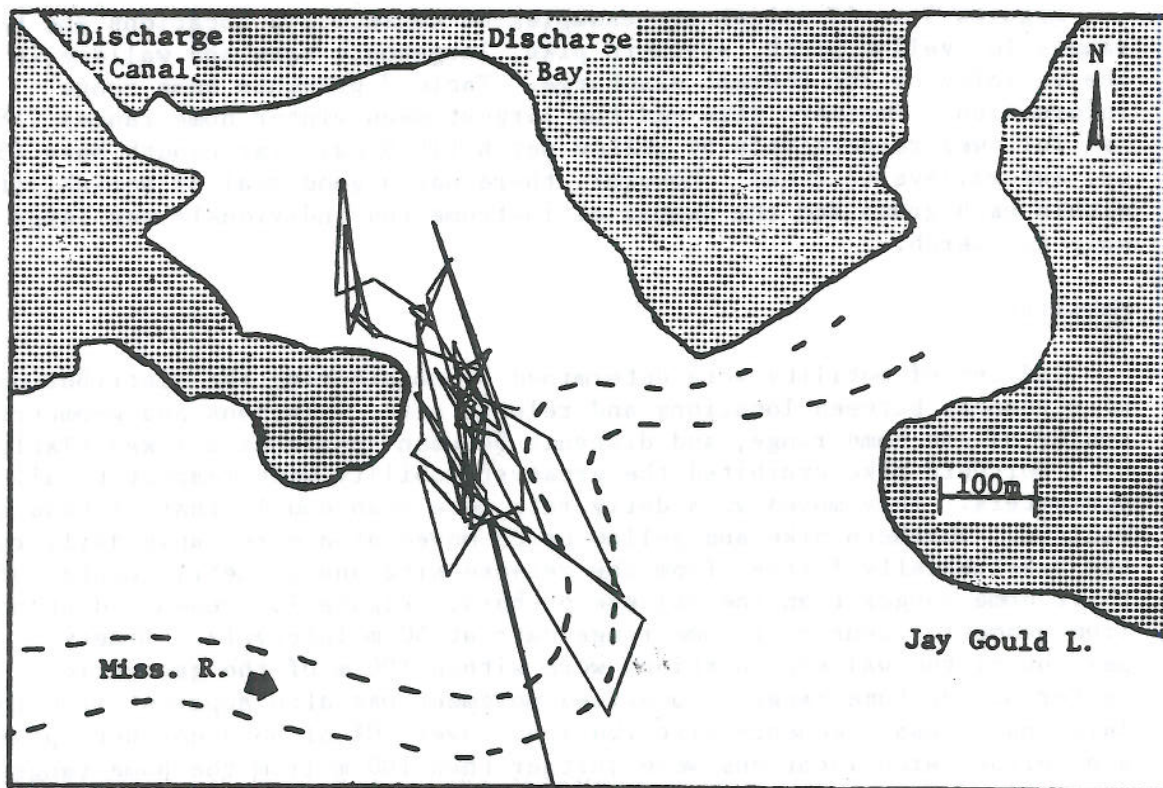

Figure 5. Movement pattern of yellow perch No. 107.

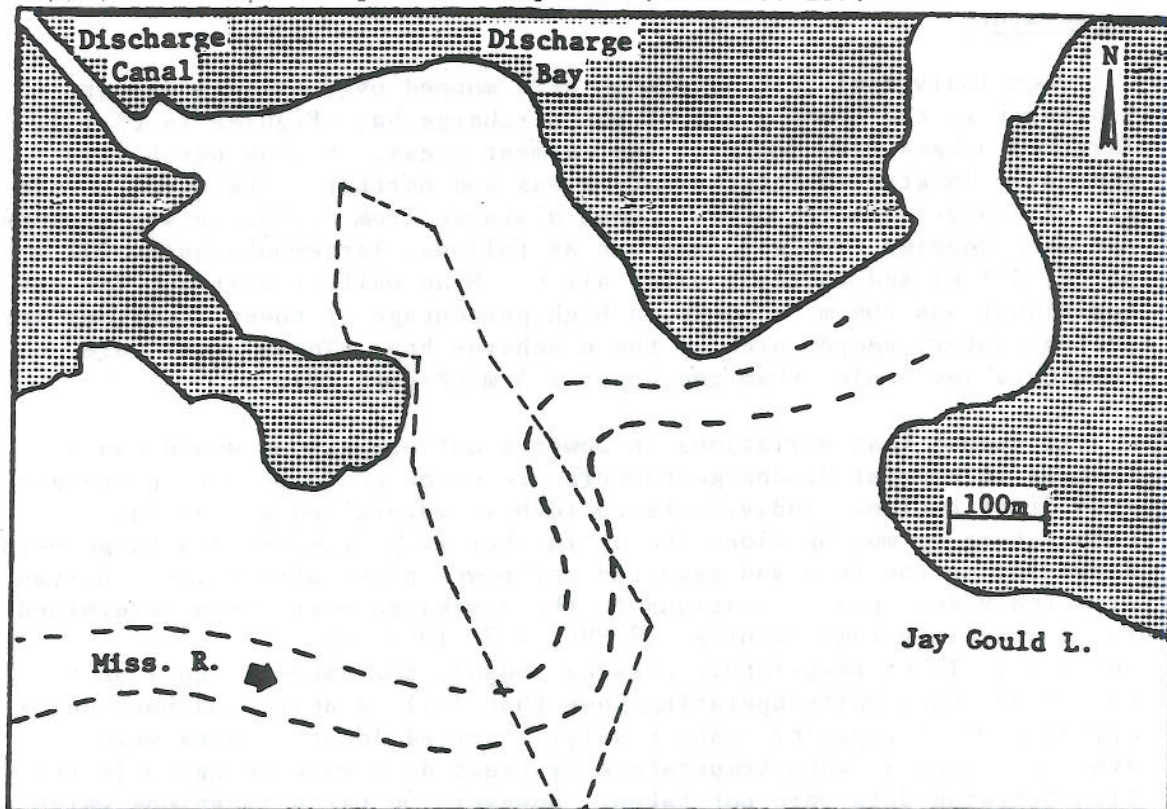

Figure 6. Home range of yellow perch No. 107.



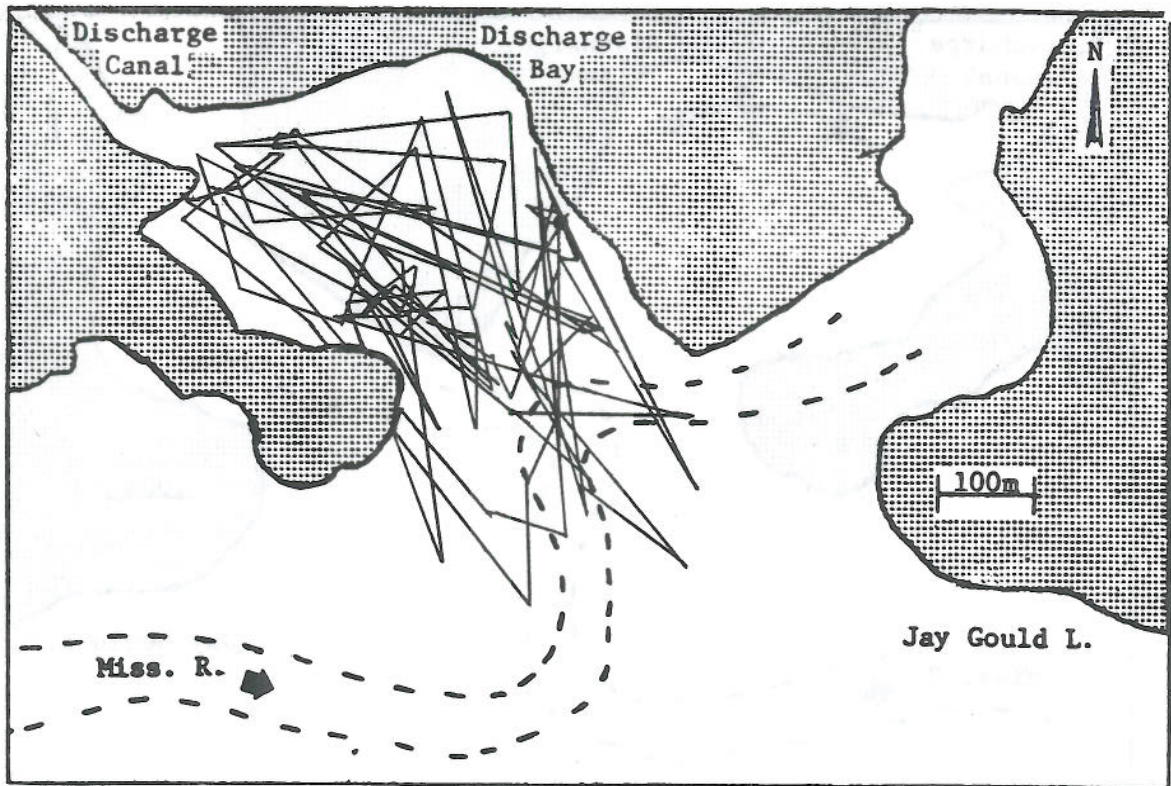

Figure 7. Movement pattern of northern pike No. 102. (⊙, capture location).

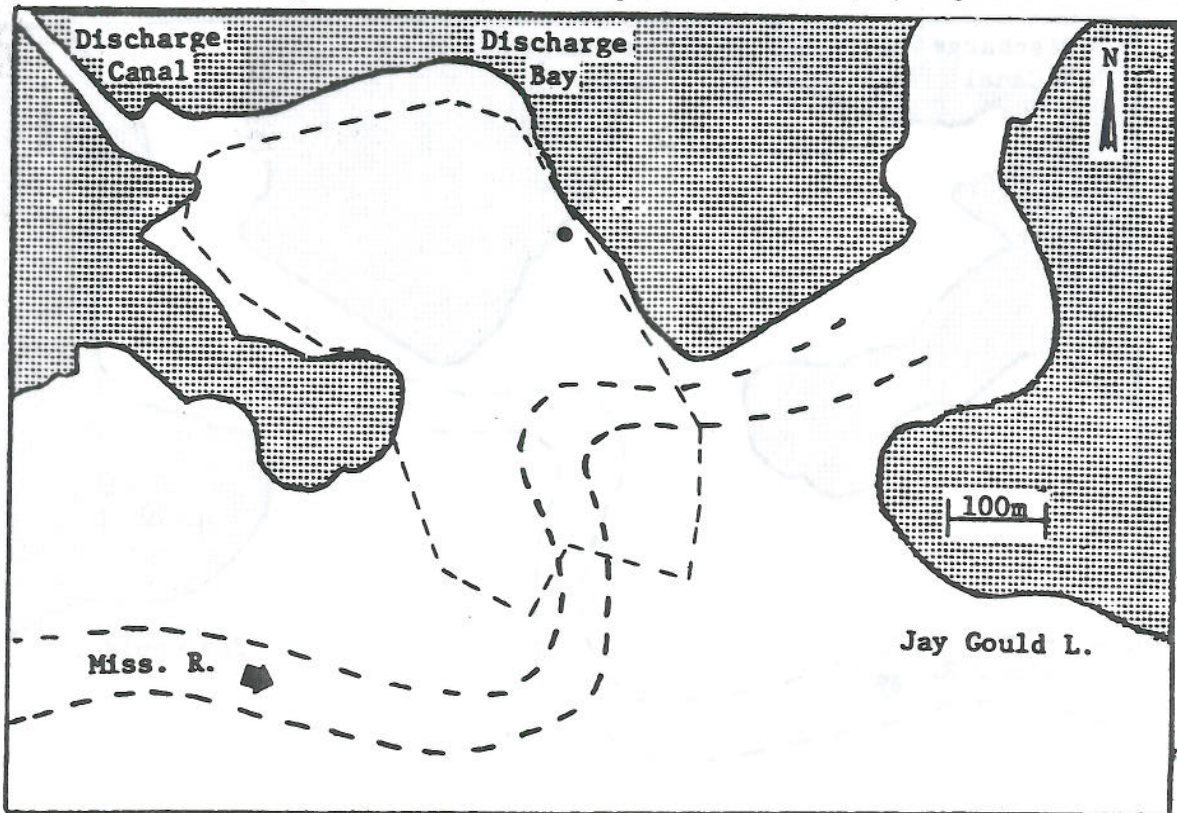

Figure 8. Home range of northern pike No. 102. (⊙, capture location).



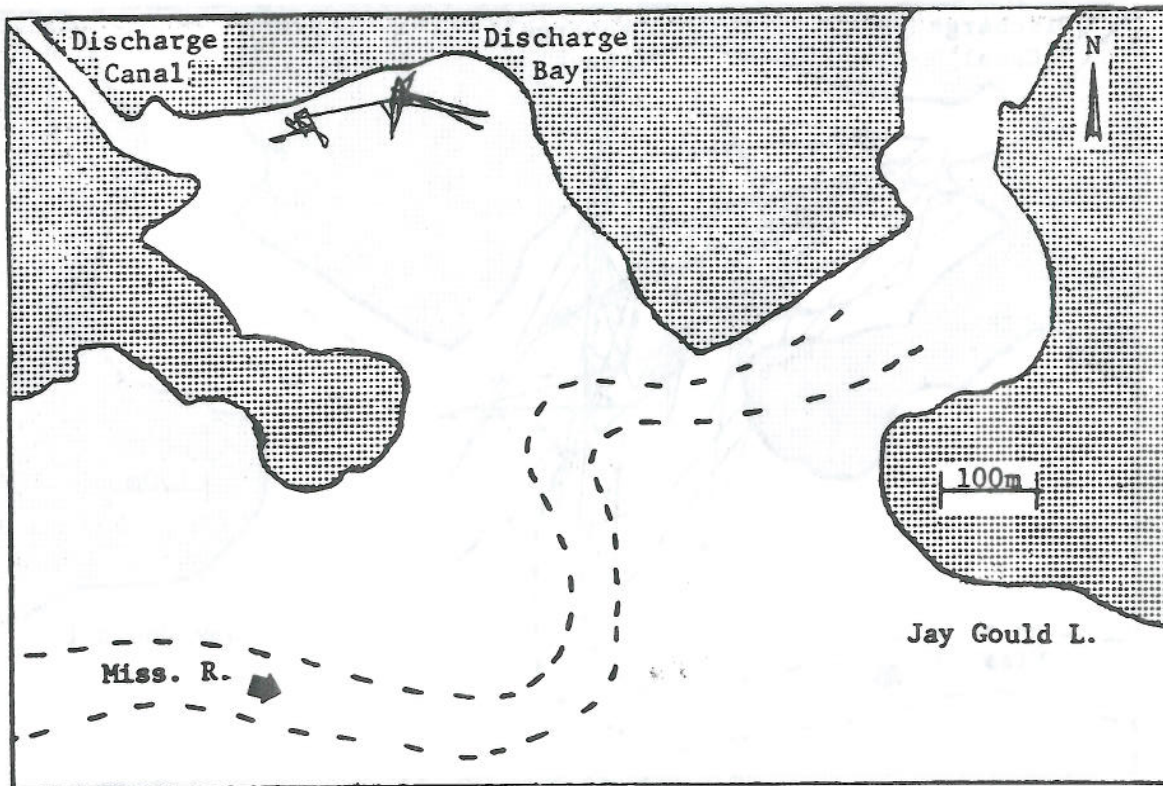

Figure 9. Movement pattern of largemouth bass No. 1011. (⊙, capture location).

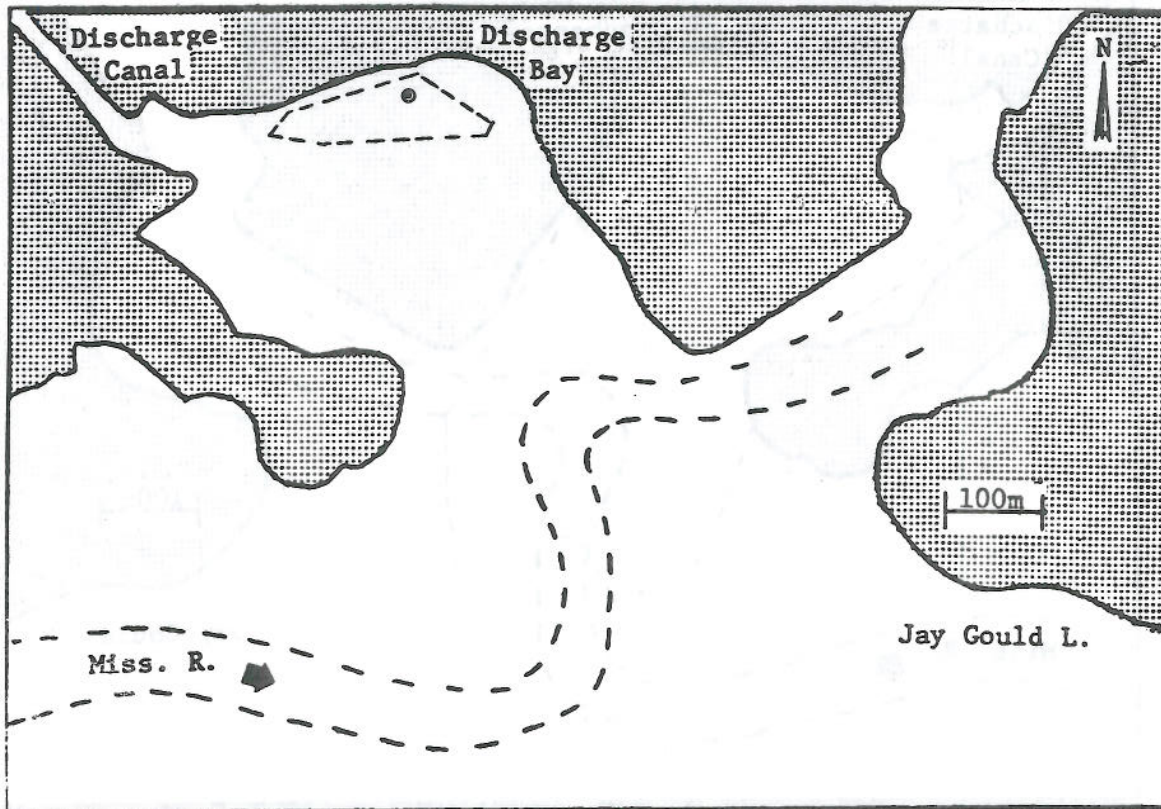

Figure 10. Home range of largemouth bass No. 1011. (⊙, capture location).



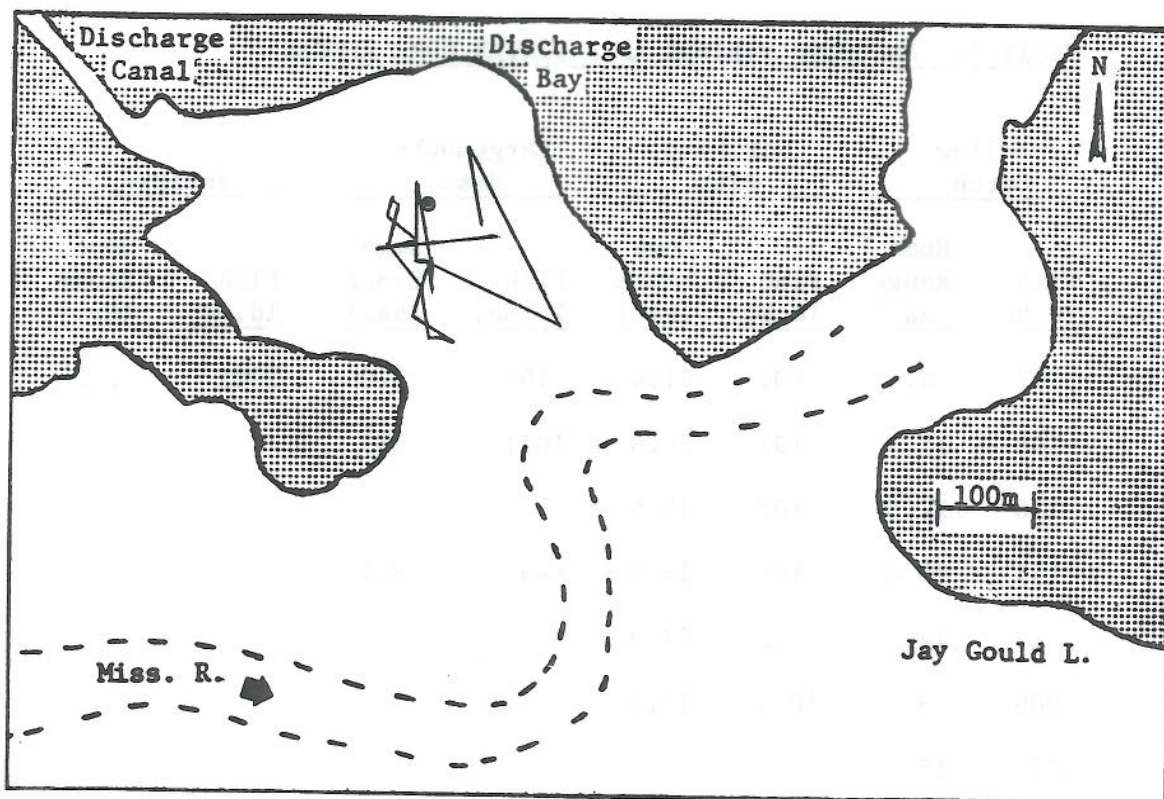

Figure 11. Movement pattern of walleye No. 1081. (⊙, capture location).

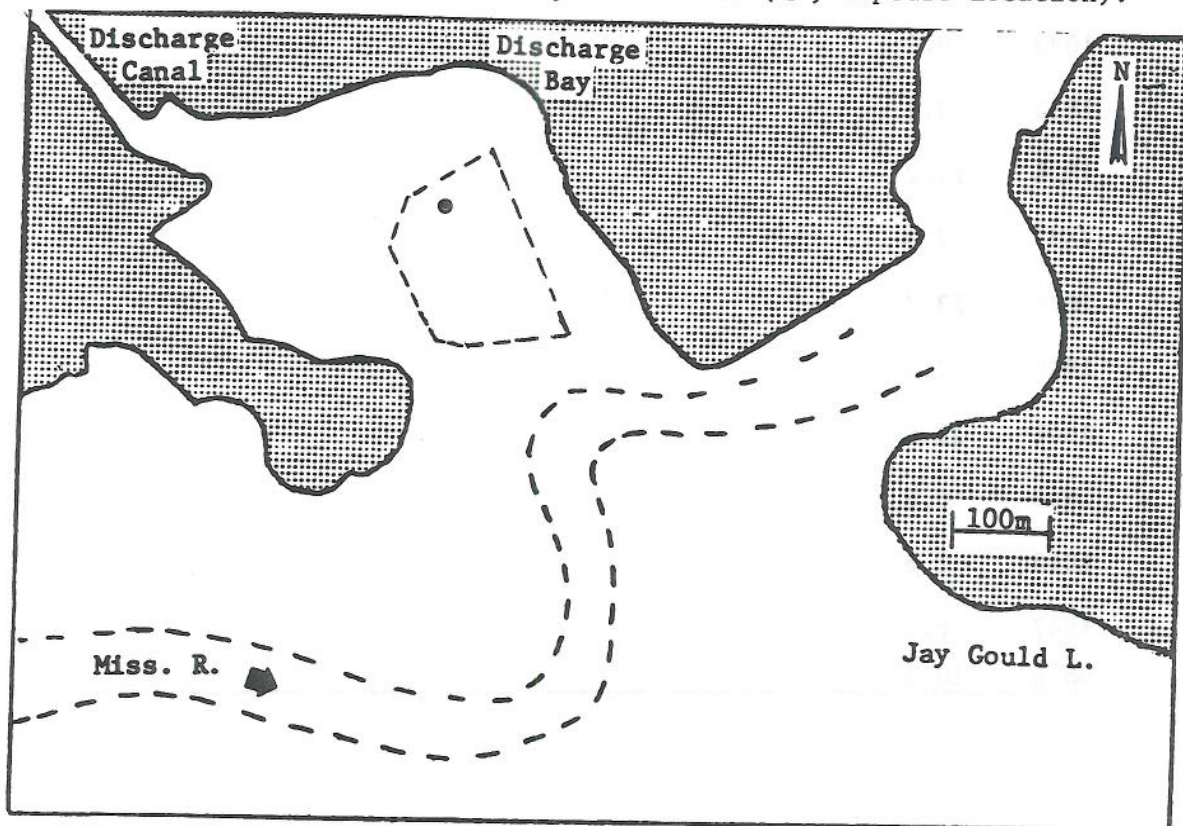

Figure 12. Home range of walleye No. 1081. (⊙, capture location).

Table 7. ADJUSTED MINIMUM AREA WINTER HOME RANGES

<u>Yellow Perch</u>		<u>Northern Pike</u>		<u>Largemouth Bass</u>		<u>Walleye</u>	
<u>Fish Id.No.</u>	<u>Home Range (ha.)</u>	<u>Fish Id.No.</u>	<u>Home Range (ha.)</u>	<u>Fish Id.No.</u>	<u>Home Range (ha.)</u>	<u>Fish Id.No.</u>	<u>Home Range (ha.)</u>
107	8.5	101	11.4	104	7.0	1081	2.2
108	11.4	102	30.8	1011	013		
110	17.8	103	15.5				
111	22.0	106	16.5	Mean	3.7		
113	14.0	1012	27.0				
1009	9.1	1015	12.6				
1014	15.4						
1017	13.0	Mean	18.9				
1033	9.2						
1833	5.2						
1834	11.2						
1837	7.3						
1838	13.7						
1840	7.4						
1841	11.0						
1842	6.8						
1843	1.6						
1847	6.0						
Mean	10.6						

Table 8. FISH MOBILITY AS MEAN DISTANCE MOVED PER DAY AND MEAN DISTANCE MOVED FROM CENTER OF HOME RANGE AND RELEASE SITE

	Largemouth Bass		Walleye		Yellow Perch		Northern Pike	
	Mean Distance	No. Individuals	Mean Distance	No. Individuals	Mean Distance	No. Individuals	Mean Distance	No. Individuals
Mean distance moved from release site (meters).	74	2	75	1	219	19	297	4
Mean distance moved from geometric center of home range (meters).	63	2	59	1	109	19	183	4
Mean distance moved per day (meters).	89	2	91	1	175	14	251	4



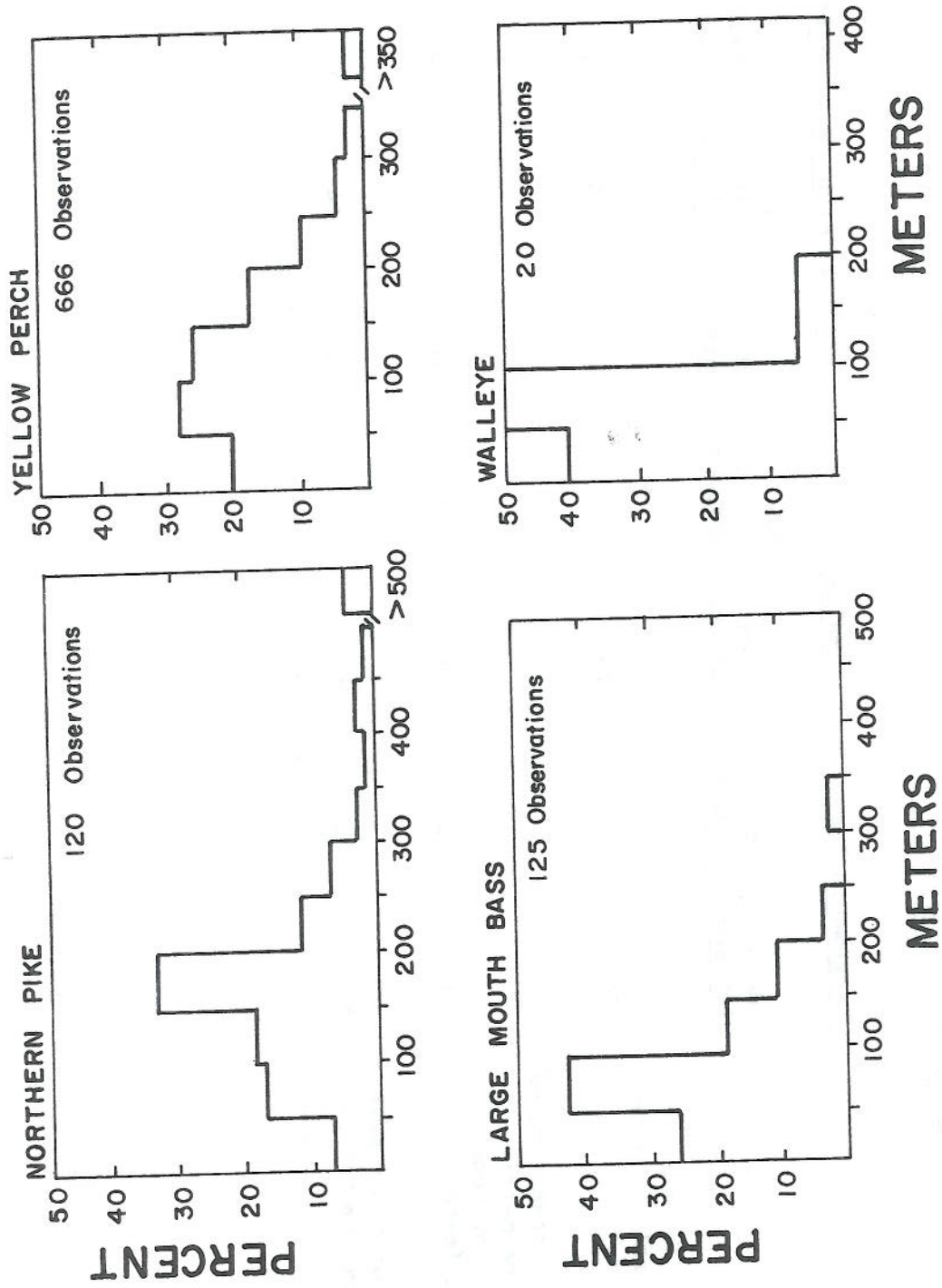

Figure 13. Distribution of fish distances from geometric center of home range.

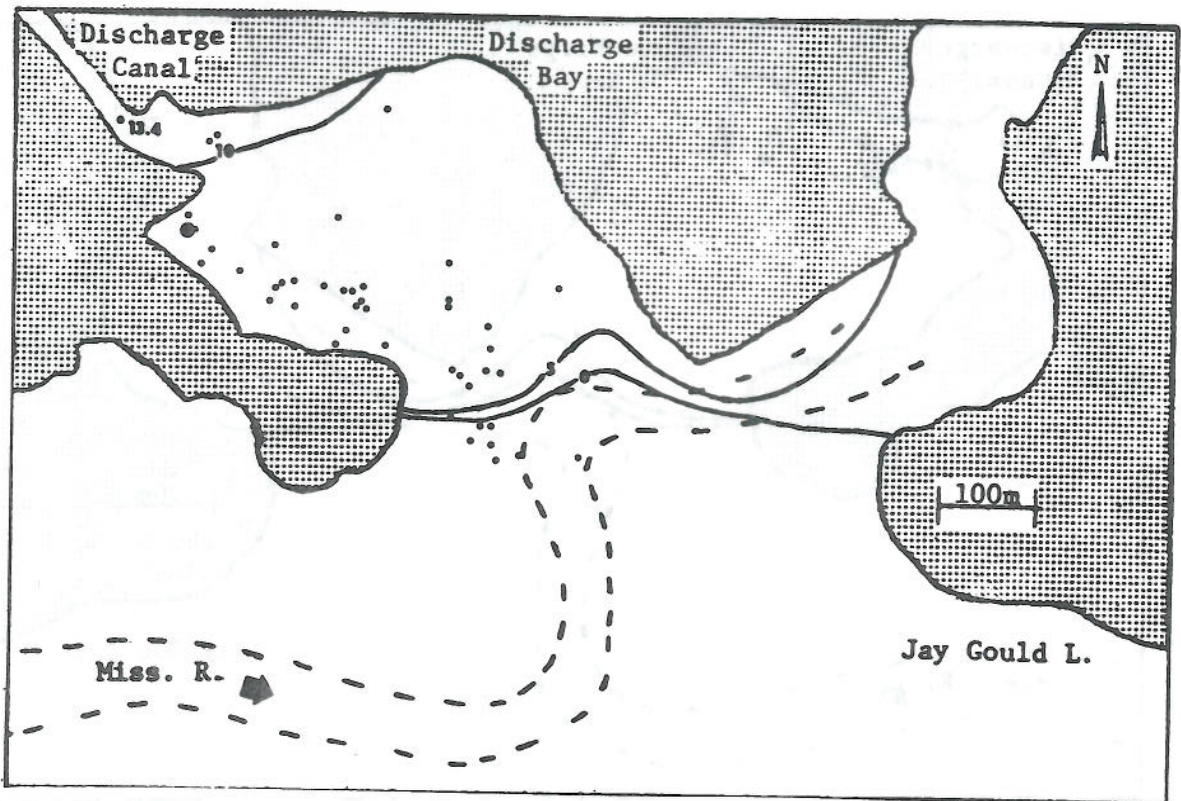

Figure 14. Yellow perch No. 113 locations relative to average winter isotherms. (°C).

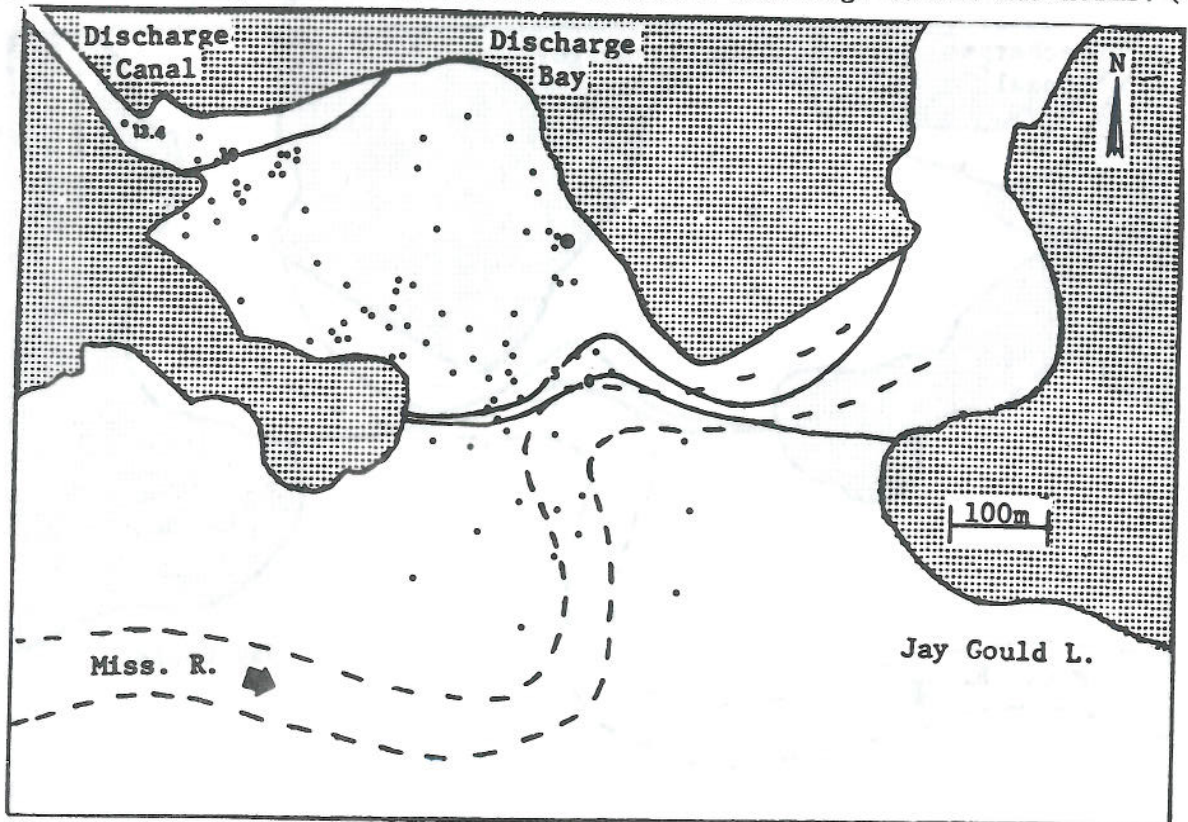

Figure 15. Northern pike No. 102 locations relative to average winter isotherms (°C).



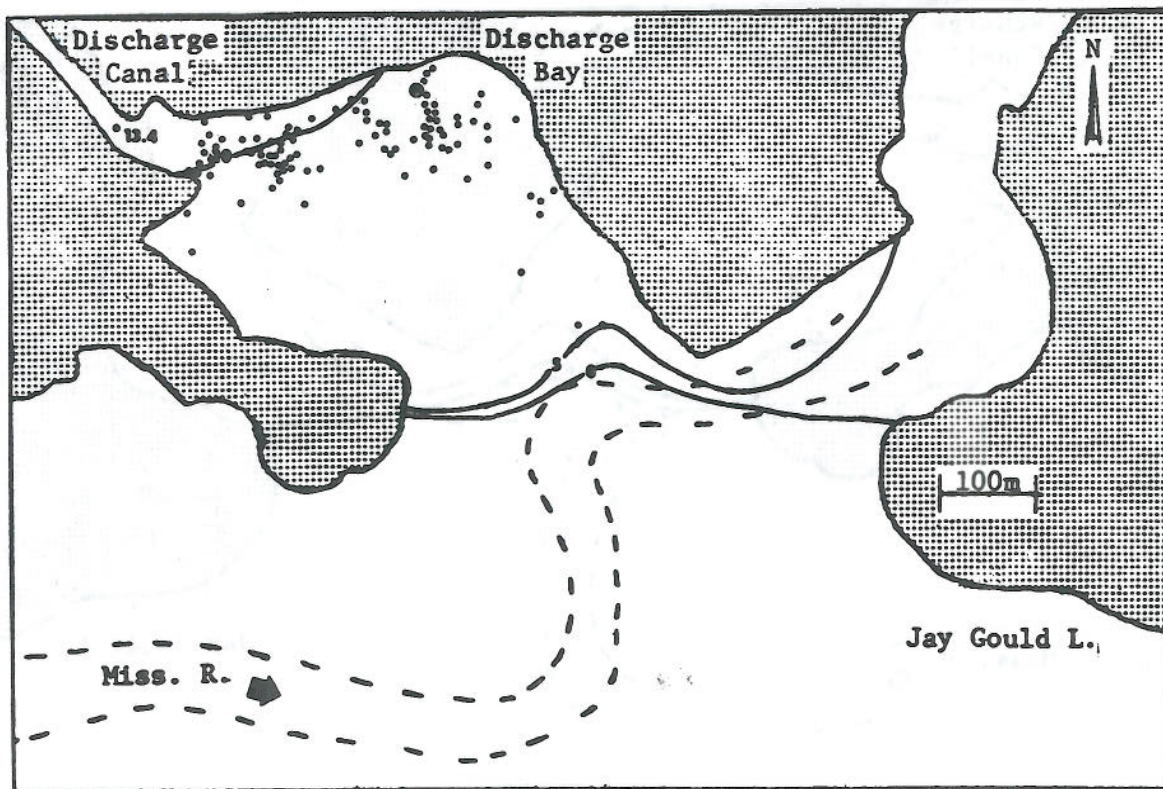

Figure 16. Largemouth bass No. 104 locations relative to average winter isotherms. (°C)

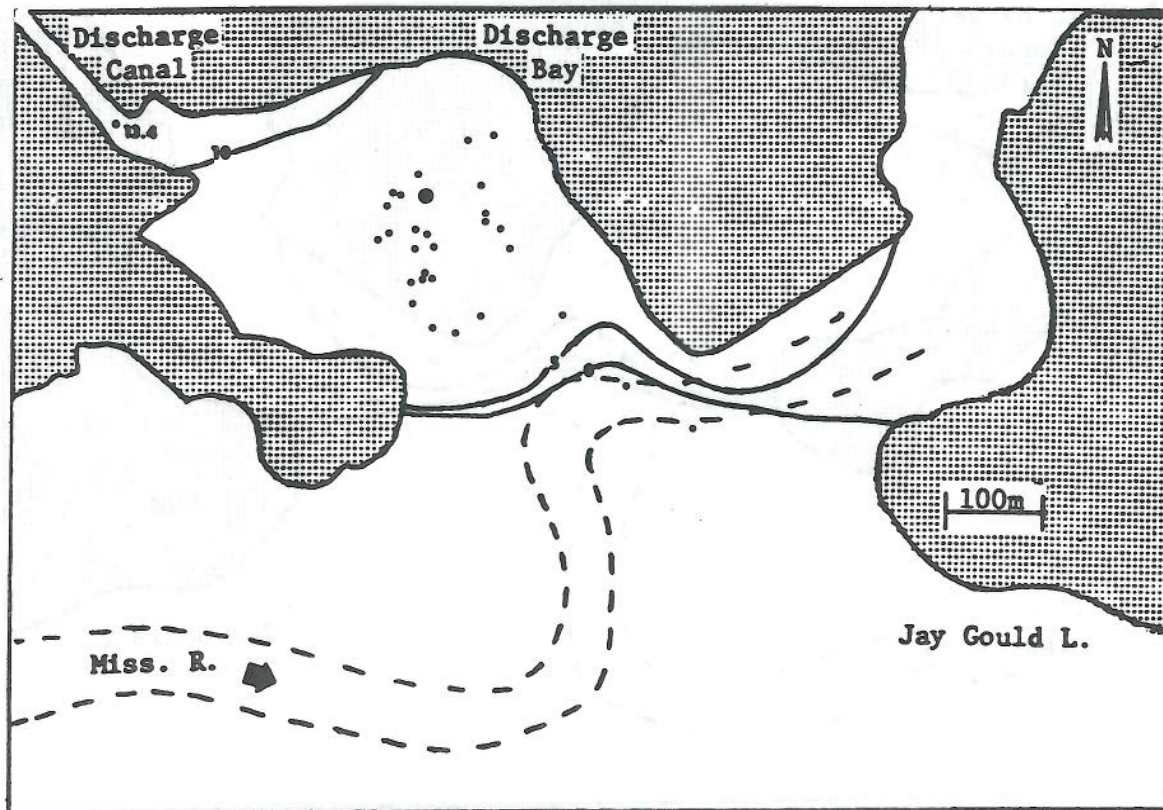

Figure 17. Walleye No. 1081 locations relative to average winter isotherms. (°C).



Table 9. MEAN FISH DISTANCE FROM DISCHARGE POINT (METERS)

<u>Yellow Perch</u>		<u>Northern Pike</u>		<u>Largemouth Bass</u>		<u>Walleye</u>	
<u>Fish Id.No.</u>	<u>Mean Dis- tance</u>	<u>Fish Id.No.</u>	<u>Mean Dis- tance</u>	<u>Fish Id.No.</u>	<u>Mean Dis- tance</u>	<u>Fish Id.No.</u>	<u>Mean Dis- tance</u>
107	537	101	556	104	229	1081	404
108	438	103	311	1011	345		
110	489	106	307	Mean	322		
111	434	1012	471				
113	368	Mean	411				
1009	429						
1014	381						
1017	432						
1033	342						
1183	433						
1833	393						
1834	299						
1837	465						
1838	428						
1840	290						
1841	459						
1842	483						
1843	470						
1847	254						
Mean	411						

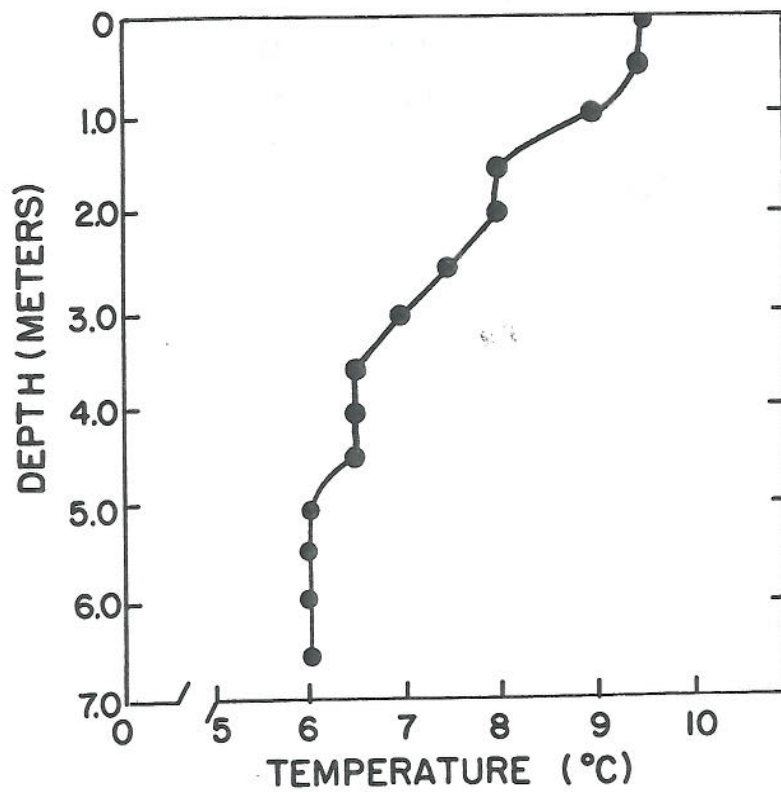

Figure 18. Discharge area mean winter water temperatures vs. depth.



were obtained within 24 hours of monitoring a discharge temperature between 5°C and 9°C had a mean distance of 467 m from the discharge point. Eight perch locations obtained at temperatures between 10°C and 13°C were found to average 341 m from the discharge point. Sixty-four locations obtained at discharge temperature between 14°C - 18°C were determined to be mean distance of 384 m from the discharge point. Analysis of variance showed these means were not significantly different ( $P < 0.05$ ) and there was no apparent pattern to perch distribution with respect to alteration in plant operations.

Table 10 presents results for fish movement between thermally modified and unaltered waters. Nineteen of 31 winter perch crossed between altered and unaltered waters at least 1 time while in the vicinity of the thermal discharge during winter months. Eighteen of 31 perch dispersed from the discharge bay during winter months. Only 2 of 31 perch remained entirely within thermally altered areas during the winter tracking period. Eight perch exhibited crossing and eventually dispersed. Eight additional perch were tracked after the peak of spawning in April 1976. All fish in this group dispersed from the discharge bay within 16 days after tagging. Of the 26 perch observed to disperse from the discharged bay 58% moved upstream 35% moved downstream and 8% moved into unaltered areas of Jay Gould Lake.

All northern pike tracked for more than 4 days moved between discharge and unaltered waters. Three individuals crossed and 3 exhibited both crossing and dispersal behavior. All 3 winter walleyes tracked also moved between altered and unaltered waters. One individual crossed 7 times. The remaining 2 walleyes exhibited both crossing and dispersal behavior. Both largemouth bass remained entirely within the discharge bay during winter months. The average number of crossings per individual for each species were: northern pike 8.5, perch 3.9, walleye 3.7, and largemouth bass 0.

The high percentage of fish, other than largemouth bass, observed crossing between thermally modified and unaltered areas, and the large numbers of perch, northern pike and walleye observed dispersing from the discharge bay implied that the thermal experience was generally transitory. This was further substantiated by looking at the number of days an individual was located in or near the discharge area as a percent of the total period the fish was tracked. For the purposes of this analysis fish that briefly crossed into nearby unaltered waters and returned to the discharge bay were counted as discharge area fish. Table 11 presents these results. The percent column may appear deceptive. Many of the fish with relatively short tracking periods remained near the discharge area. However, a strong bias toward discharge area locations existed because all fish were captured and released in the discharge bay. Additionally, tracking periods could only extend to the life of the transmitter. If thermal experience was transitory, a better indicator should have been found by limiting the analysis to those fish that were tracked for protracted time periods. Only 1 of 3 northern pike tracked

Table 10. FISH MOVEMENT WITH RESPECT TO THERMALLY ALTERED AND UNALTERED AREAS

Fish Id.No.	Crossings	Dispersal Date	Dispersal Location			Season & Year
			River Downstream	River Upstream	Jay Gould Lake	
<u>Yellow Perch</u>						
107	8					Winter 1975
108	7					
109	8	3/15/75	X			
110	22					
111	4					
113	10	4/6/75	X			
1009	2					
1013	0	4/24/75	X			
1014	12					
1016	4	4/27/75	X			
1017	10					
1018	4	4/24/75	X			
1032	6	5/10/75		X		
1033	2					
1153	2	4/29/75		X		
1159	2	5/4/75		X		
1183	9					
1833	0	1/20/76		X		Winter 1976
1834	0					
1836	0	2/16/76		X		
1837	0	3/26/76	X			
1838	0	3/23/76		X		
1839	0	2/25/76		X		
1840	0					
1841	3	2/28/76	X			
1842	0	2/25/76		X		
1843	6					
1844	0	1/21/76	X			
1846	0	2/27/76		X		
1847	2					
1848	0	4/7/76			X	
1850		4/18/76	X			Spring 1976
1851		4/26/76		X		
1852		4/23/76		X		
1853		4/18/76		X		
1854		4/15/76		X		
1855		4/15/76		X		
1856		4/21/76		X		
1857		4/24/76			X	

Table 10. (continued) FISH MOVEMENT WITH RESPECT TO THERMALLY ALTERED AND UNALTERED AREAS

Fish Id.No.	Crossings	Dispersal Date	Dispersal Location			Season & Year
			River Downstream	River Upstream	Jay Gould Lake	
<u>Northern Pike</u>						
101	6					Winter 1975
102	26	4/6/75		X		
103	5					
106	4					
1012	2	4/27/75			X	
1015	6	4/27/75	X			
<u>Walleye</u>						
100	7					
1057	2	4/15/75		X		
1081	2	5/9/75		X		
<u>Largemouth Bass</u>						
104	0					
1011	0					





Figure 20. Walleye No. 1081 locations relative to depth.

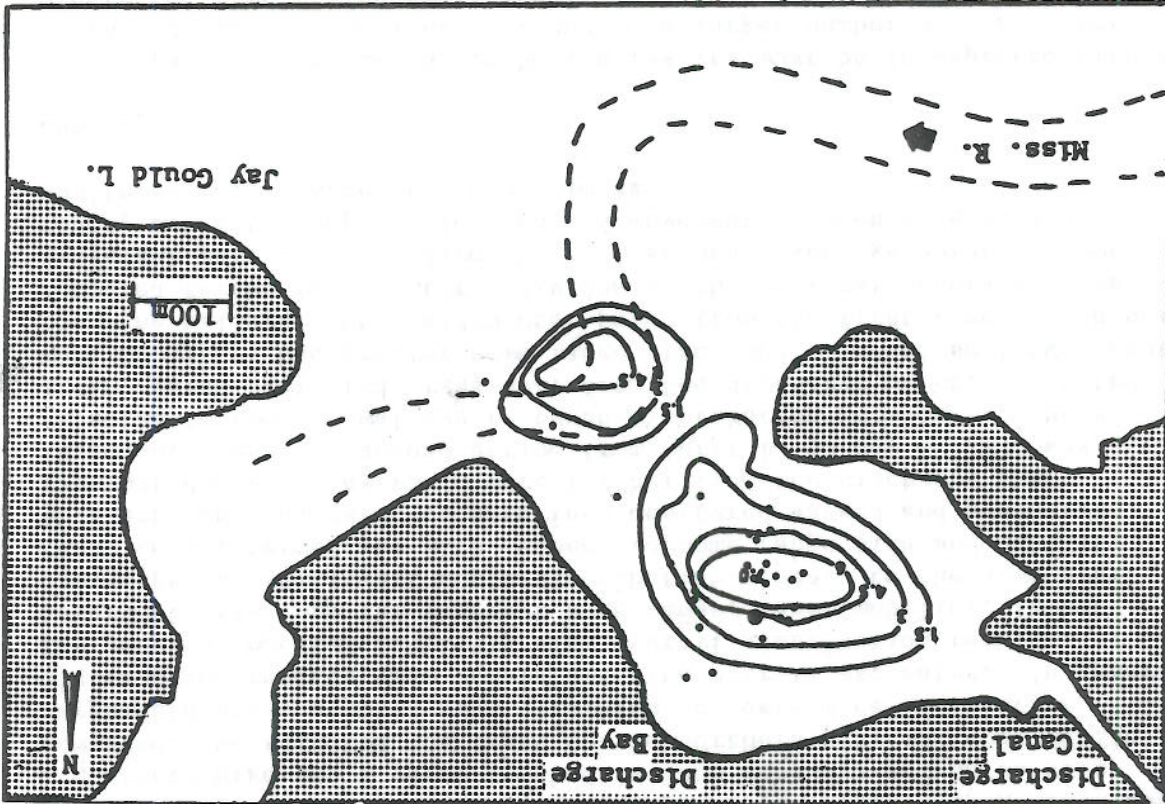
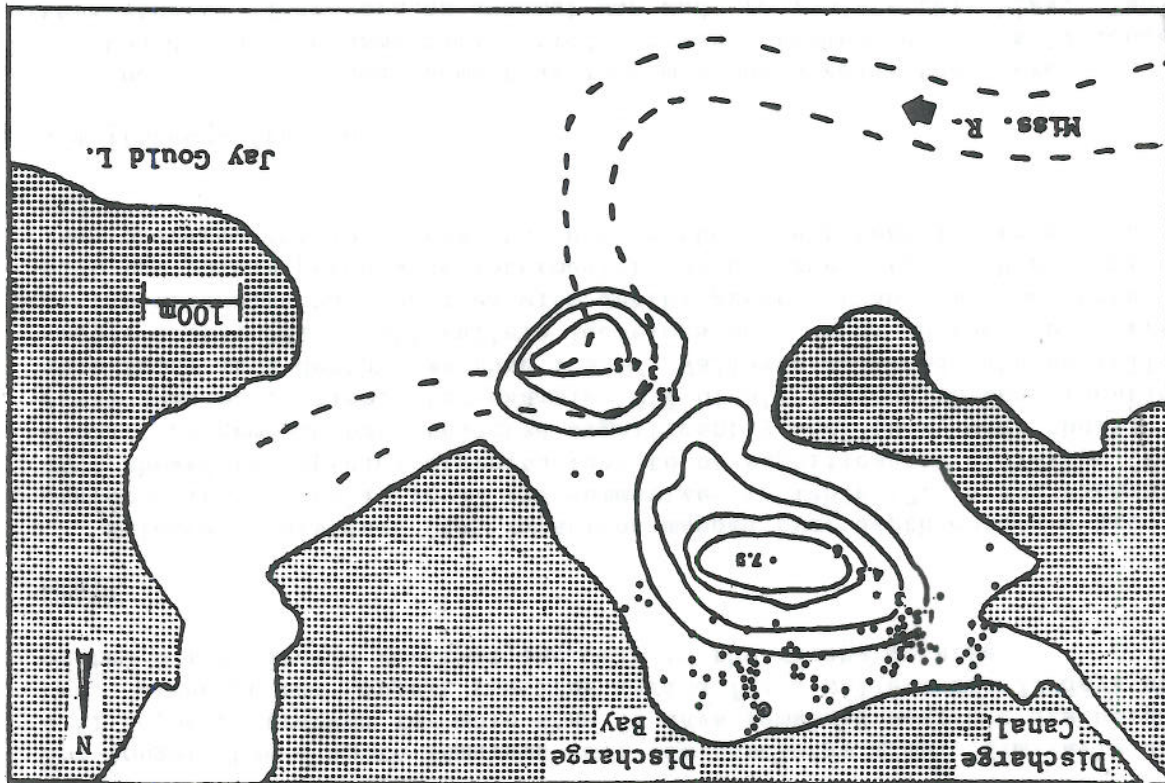

Figure 19. Largemouth bass No. 104 locations relative to depth.





Comparative species distribution results must be interpreted with a certain degree of caution. Obviously, a larger number of fixes over a protracted time period could result in larger home ranges, more

### Summary

There may have been some bias in comparing species that were not tracked during the same time periods or were tracked considerably longer than others. Therefore an attempt was made to isolate this bias. Table 13 presents summary results for 2 time intervals when fish of various species were tracked over similar time periods. First 1 largemouth bass, 1 northern pike and 2 perch tracked in late February and March were compared. We selected the least mobile northern pike and most mobile largemouth bass, a worst case situation, to determine if relative distribution results were consistent with overall estimates. In general, the results compared favorably with overall distribution results. Largemouth bass had the smallest home range, least mobility, fewest crossings and shallowest depth distribution closest to the discharge. Perch were intermediate with respect to home range size and mobility. Northern pike and perch crossed into unaltered waters and preferred somewhat deeper areas which were further from the discharge than largemouth bass. A second period from April 12 to May 4, 1975 was selected to compare walleye to perch distribution parameters. Here again, perch preferred areas away from the discharge point, exhibited more mobility, had greater home range sizes and selected shallower depths than the walleye. When mid-winter perch from the first time period were compared to the late winter individuals, the only parameters noticeably different were distance from the release and discharge points. Home range, mobility, depth selection and movement between altered and unaltered waters appeared to be similar.

### Simultaneous Tracking

Selected individual fish locations mapped over depth contours are depicted in Figures 19 to 22 and summarized in Table 12. A chi-square test showed the species distributions to be significantly different ( $P < 0.05$ ). Largemouth bass selected significantly shallower, near shore, areas than other fish. For example, 95% of all largemouth bass locations were found at a depth less than 1.5 m. Walleyes selected substantially deeper areas; 58% of all walleye locations were found in the center areas of the discharge bay, an area with depths greater than 3 m. Northern pike and yellow perch were intermediate with respect to depth selection. They preferred shallow areas, but not to the extent that largemouth bass did.

### Depth

for longer than a month remained near the discharge area. Similarly only 4 of 14 perch tracked for more than 31 days remained near the discharge bay. Although the longest tracking period for a walleye was 22 days none of the 3 individuals remained entirely in the discharge area.



Figure 22. Northern pike No. 102 locations relative to depth.

45

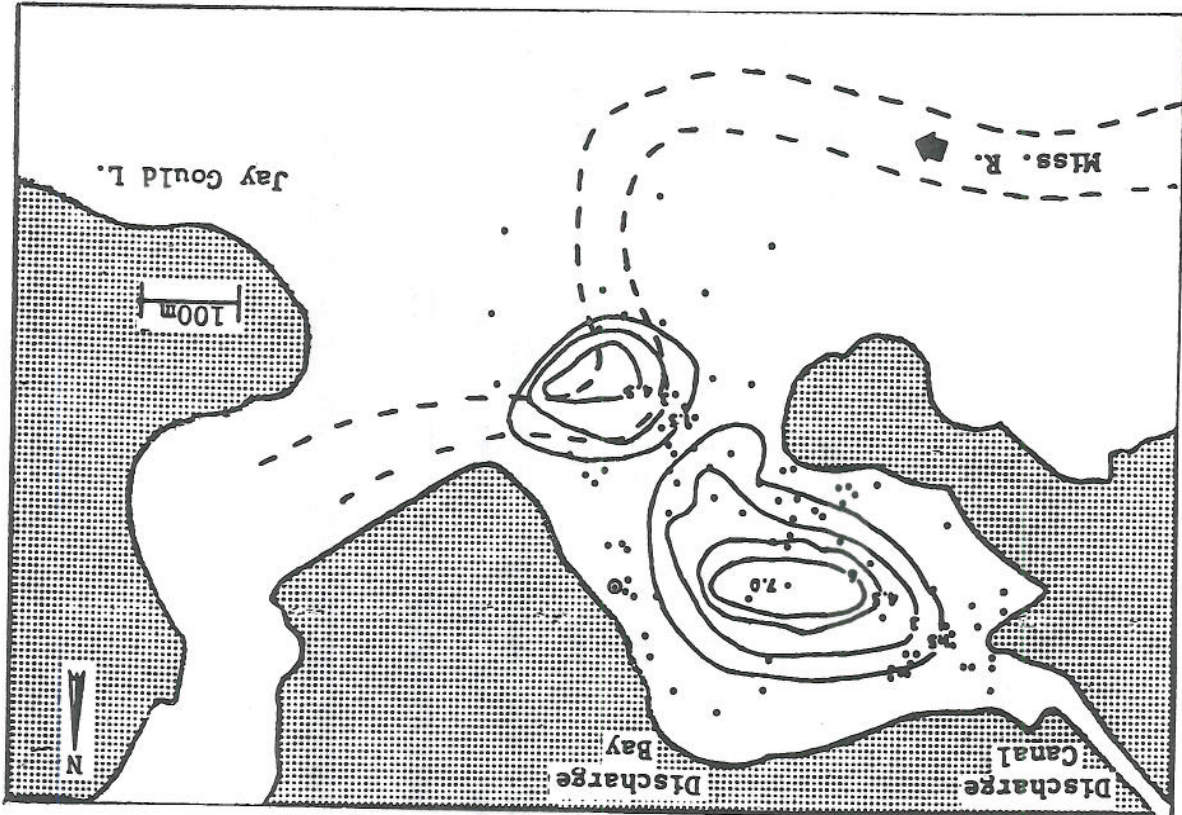

Figure 21. Yellow perch No. 113 locations relative to depth.

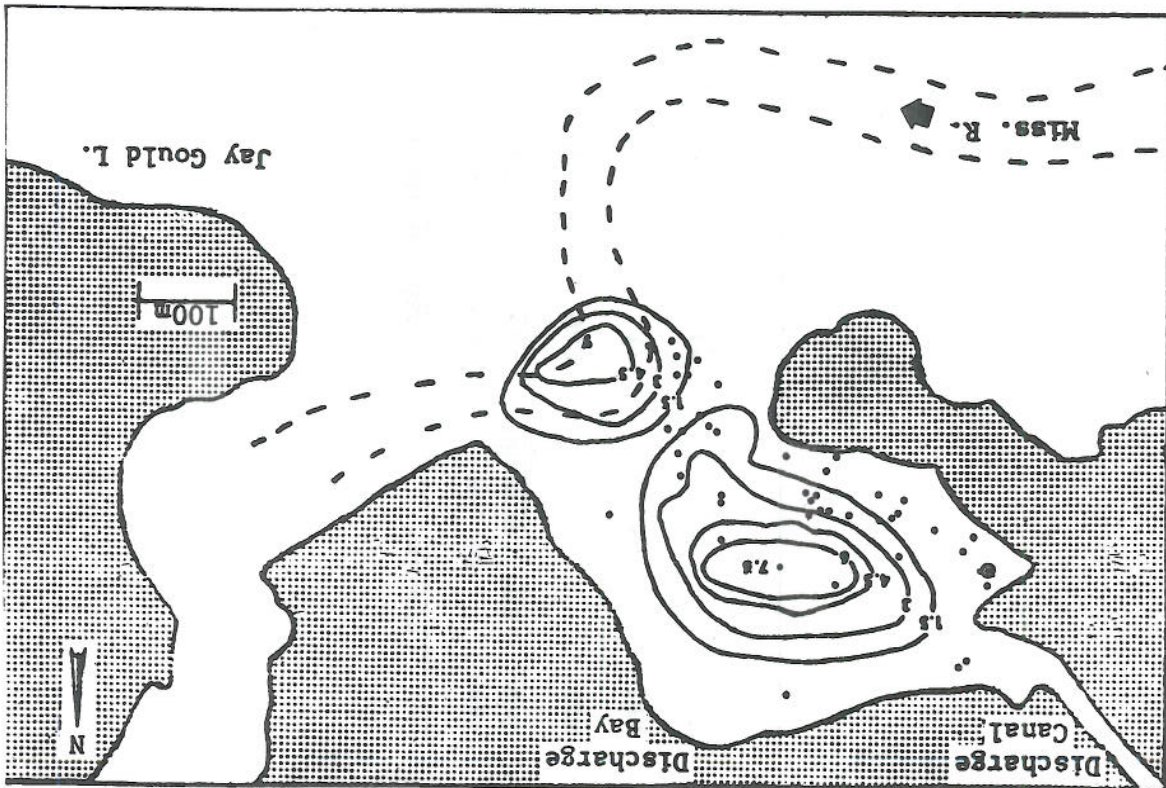

Table 12. DEPTH SELECTION BY FISH IN THE DISCHARGE AREA

Depth	Perch		Northern Pike		Largemouth Bass		Walleye	
	No. of Observations	Per-cent	No. of Observations	Per-cent	No. of Observations	Per-cent	No. of Observations	Per-cent
0.0-1.5m	541	71%	154	78%	130	96%	7	24%
1.5-3.0m	122	16%	34	17%	5	3%	5	17%
> 3.0m	97	13%	10	6%	1	1%	17	59%

Chi-Square 0.95, 6 D.F. = 12.6.

Table 13. A SUMMARY OF RESULTS FOR TWO PERIODS WHEN FISH WERE TRACKED CONCURRENTLY

Species	Fish Id.No.	Tracking Period No. Days	Locations No.	Home Range (ha)	Daily Movement Rate (meters/day)	Mobility			Temp	Cross-sings	Depth		
						Distance From Release (meters)	Dist. moved from Geo center of Home Range (meters)	Dist. from Discharge (meters)			0.0-1.5 (meters)	1.5-3.0 (meters)	> 3.0 (meters)
Yellow Perch	107	25	55	8.5	230	312	112	534	8	35	1	3	
	108	25	51	11.4	221	268	125	437	5	33	3	13	
	$\bar{x}$	25	53	9.9	226	290	119	495	7	34	2	8	
Northern Pike	103	16	32	14.1	237	365	174	306	2	30	1	1	
Largemouth Bass	104	25	48	3.3	132	123	99	279	0	46	2	0	
A p r i l 1 2 t o M a y 4, 1 9 7 6													
Yellow Perch	1017	23	38	12.4	215	152	114	423	10	16	11	9	
	1033	20	38	9.1	203	123	108	342	2	30	4	4	
	$\bar{x}$	22	38	10.8	209	138	109	387	6	23	8	7	
Walleye	1081	18	23	2.5	73	74	64	409	0	5	2	16	



crossings, higher daily movements, etc. The tracking period was determined by the transmitter life as determined by the battery size an individual could carry. Also, fish were tracked over non-coincidental time intervals on an irregular schedule. However, each time fish were tracked we attempted to locate all individuals regardless of species which minimized bias.

The nature of telemetry limits the number of individuals that can be tracked at a given time; thus, fish had to be grouped without regard to size or sex. All fish analyzed were adults grouped by species and season. This fact probably accounts for a portion of the intraspecific variability and the lack of more clear-cut interspecific differences. However, the overall results generally agreed with those obtained by selecting limited periods when the species were tracked concurrently.

Our radio tags did not transmit depth data per se. Depth was inferred from location. Conceivably, an individual could have been at any depth in the water column at a given location. However, as Holt et al. (1977) pointed out, walleyes are a demersal species and the probability that this species was near the bottom at any given time was high. Erikson (1975) found that during the winter *Perca fluviatilis* (a closely related European perch species) remained at the bottom of a laboratory tank. Therefore, the assumption in determining comparative depth data was likely valid for these species.

In general, perch were found to have a home range size less than northern pike and greater than largemouth bass and walleye. This species preferred shallow areas distal from the discharge point. A high percentage of the individuals either crossed between the discharge bay and unaltered waters or dispersed from the discharge bay. Perch mobility as measured by distance moved from center of home range, release site and daily movement rates was determined to be less than northern pike and greater than walleye or largemouth bass. Perch locations with respect to changes in plant operations showed no significant difference or pattern.

Northern pike generally exhibited the largest mean home range and were the only species to have mean home range size larger than the discharge bay. This species also preferred relatively shallow areas. Northern pike showed the greatest variability with respect to distance from the discharge and were found to virtually cover the entire discharge bay. They demonstrated the most mobility and crossed between thermally altered and unaltered waters more often than any other species. No northern pike tracked for more than 4 days remained entirely in the discharge bay.

Largemouth bass had a small home range and preferred significantly shallower areas closer to the discharge than northern pike or yellow perch. Largemouth bass movement from center of the home range, release site and daily movement rates were determined to be substantially less than that of northern pike and yellow perch. The 2 largemouth bass remained entirely within thermally altered areas during their tracking periods.



Nine perch and 1 walleye were radio tagged downstream during the Autumn of 1975. Figure 25 shows a typical location pattern of a perch downstream from the discharge. Initially fish trapping below the discharge and mixing zones was difficult due to strong currents. Thus, 4 of 9 'downstream' perch were not radio tagged until November 27. By this time, normal river temperatures had cooled to 0°C. Discounting these last 4 perch, 3 of 5 perch moved through the mixing zone during the autumn cooling period. Two individuals subsequently moved into thermally

Blackwater Lake upstream from the discharge. During the fall months of 1975 and 1976, fish were trapped and released in areas where radio tagged fish had dispersed the previous spring. We tracked 62 yellow perch and 3 walleyes captured in areas upstream and downstream from the thermal discharge and 2 walleyes from the discharge area for a minimum of 7 days. Table 14 summarizes the results. Autumn tracking commenced in September 1975 when the normal river temperature was 13°C and discharge temperature was 20°C. Tracking continued until December when normal river temperatures had dropped to 0°C and discharge temperatures to 10°C. Nine yellow perch were tracked upstream from the discharge. Figure 24 depicts the distribution of daily locations of a typical perch upstream from the thermal discharge. All individuals remained in waters under normal seasonal temperature conditions. Only 1 fish made a substantial move downstream toward the discharge area, however, this perch moved into the thermally unaltered area of Jay Gould Lake. Three perch moved into the northwest bay of Blackwater Lake that supplies water to the intake of the power plant. The remaining 5 perch remained in shallow areas of

The high percentage of yellow perch observed dispersing from the discharge area during the late winter and early spring months resulted in an expansion of the project. We speculated yellow perch would return to thermally altered areas the following autumn as the river cooled, and the fish followed the thermal gradient to maintain temperatures closer to reported temperature preferences. Fish approaching the discharge confluence with the river could have reacted positively and moved into the discharge bay. A negative reaction would have been observed if the fish encountered the gradient and either turned back or continued moving through the periphery to thermally unaltered areas. Figure 23 presents average fall isotherms in °C above ambient, depicting the gradient present during this phase of the investigation.

#### AUTUMN DISTRIBUTION RESULTS

Limited data were available on walleye as only 1 individual was successfully tracked while maintaining a home range in the discharge bay. This individual had a small home range in the center deep area of the discharge bay. Mobility was less than that of perch and northern pike. All 3 walleyes tracked during winter months moved between thermally altered and unaltered areas. Two individuals dispersed shortly after instrumentation.

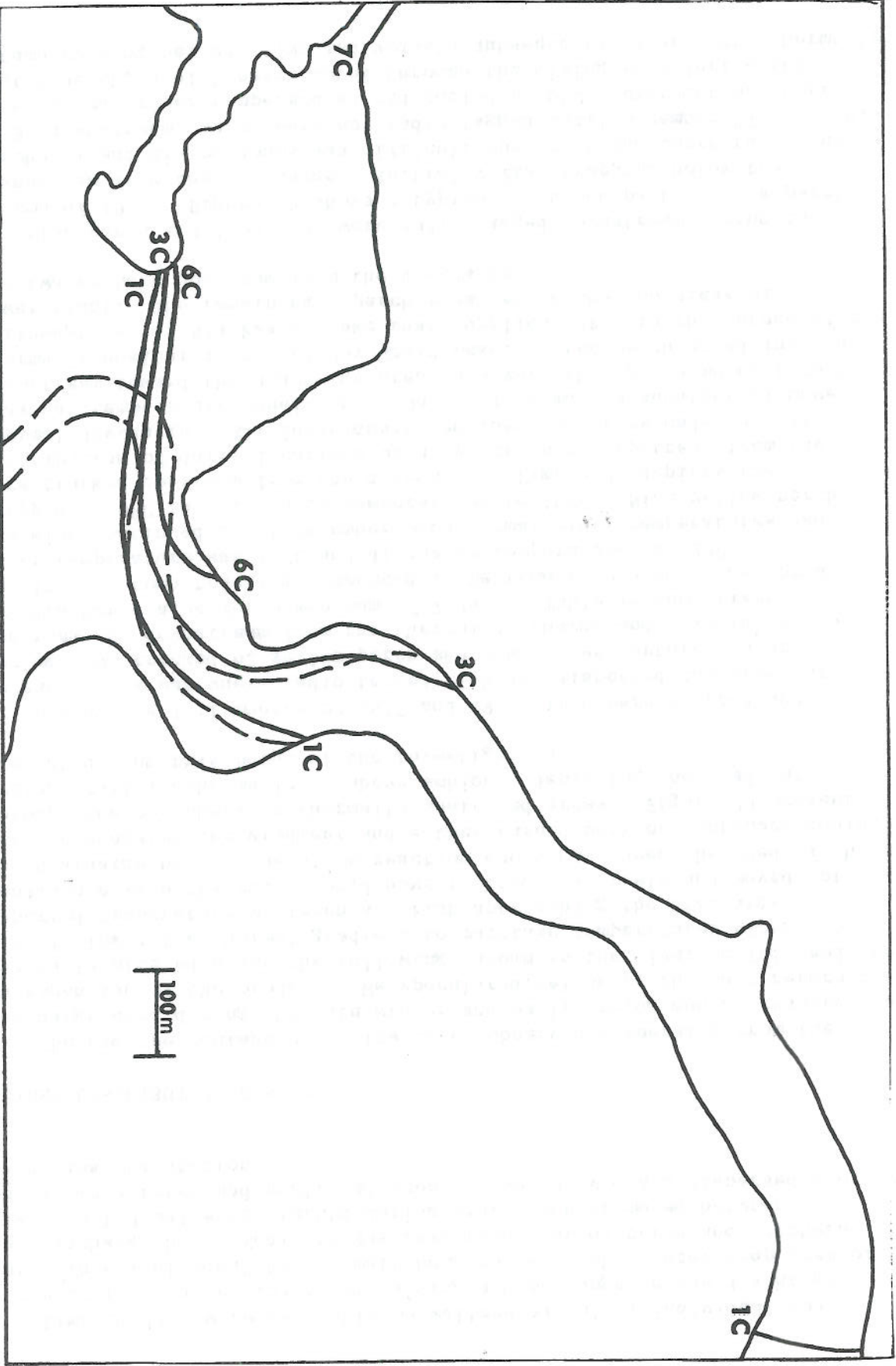

Figure 23. Average fall isotherms (°C above ambient). (Modified from MP & L, by permission.)



Table 14. AUTUMN YELLOW PERCH MOVEMENT

	<u>No. Tracked</u>	<u>No. moved toward Discharge</u>	<u>Per-cent</u>	<u>No. moved into Discharge</u>	<u>Per-cent</u>	<u>No. Tracked</u>	<u>No. moved toward Discharge</u>	<u>Per-cent</u>	<u>No. moved into Discharge</u>	<u>Per-cent</u>
1975	9	1	11%	0	0%	5	3	60%	1	20%
1976						48	32	67%	1	2%
Total	9	1	11%	0	0%	53	35	66%	2	4%

Figure 24. Movement of perch No. 1813 from October 7, to November 19, 1975 as it remained upstream from the discharge area.

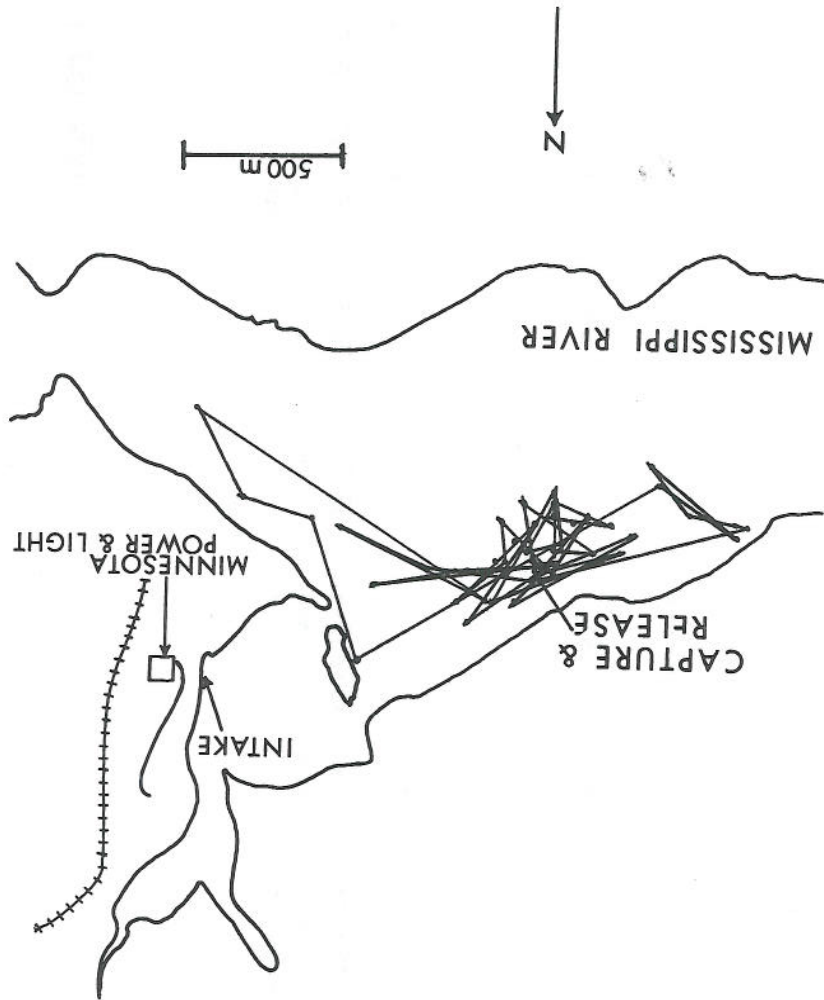
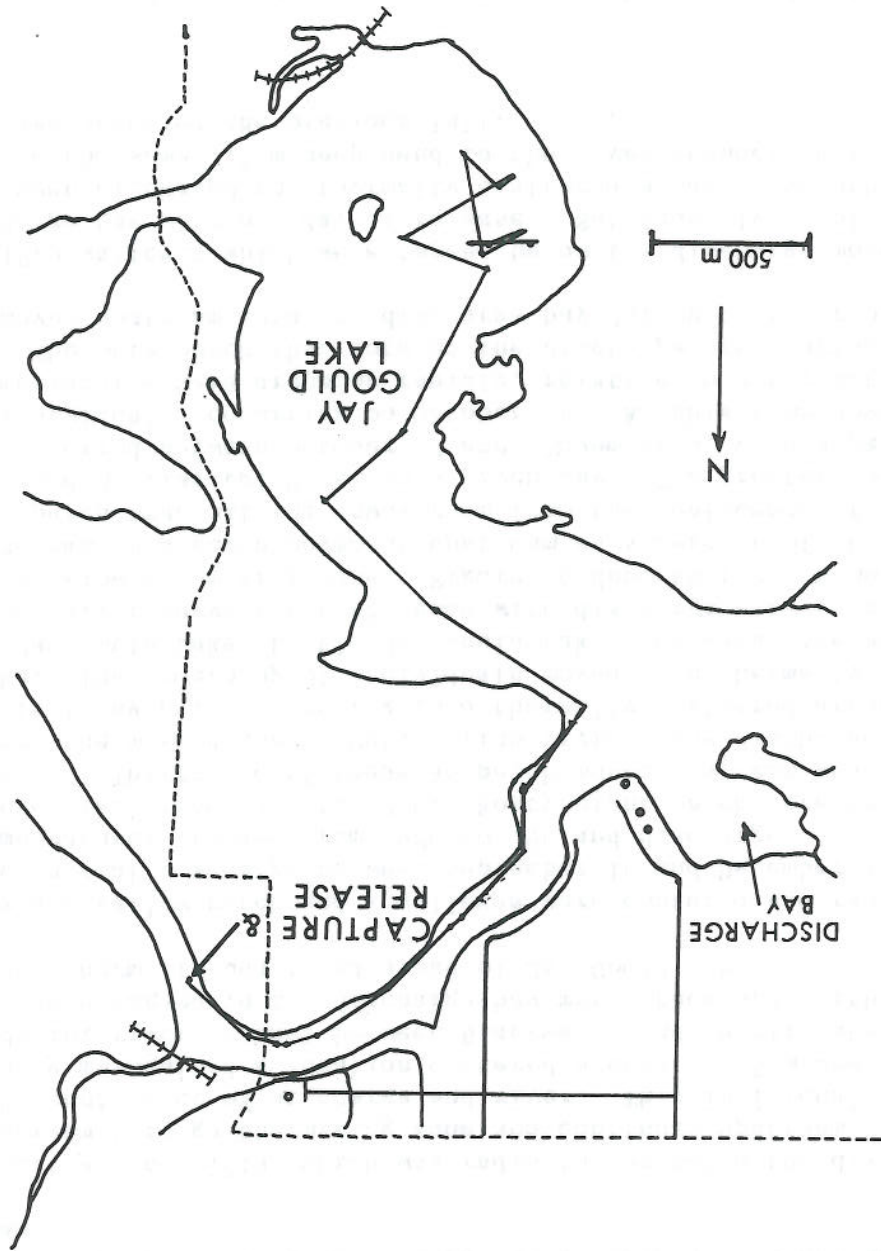



Figure 25. Movement of yellow perch No. 1817 from October 9 to November 1, 1975 as it moved upstream from below the mixing zone into Jay Gould Lake.



The results of two autumn seasons fish tracking outside of the thermal discharge bay indicated 35 of 53 perch tracked below the discharge moved upstream through the mixing zone. Only 2 of the 35 continued in a positive direction through the thermal gradient into the discharge bay. Furthermore, these 2 perch remained in the thermally modified area only for a short period of time. None of the 9 perch tracked above the discharge - river confluence moved into thermally altered waters. Five walleyes tagged during the fall months appeared either to oscillate between discharge and thermally unaltered waters or to move upstream beyond the mixing zone.

### Summary

unaltered areas of Jay Gould Lake. Only 1 individual continued to move up the gradient into the discharge area. This perch remained in the discharge area for a 5 day period after which it also moved into Jay Gould Lake. Due to these observations, we shifted all future autumn work downstream.

One walleye (no. 1814) which was radio tagged below the discharge moved upstream through the mixing zone and continued upstream 2.5 km beyond the confluence of discharge and river. This individual subsequently maintained a location centered around a 3.5 m deep bend in the meandering river channel between Blackwater and Cutoff Lakes. Two walleyes radio tagged in the discharge bay moved back and forth between the bay and thermally unaltered areas of Jay Gould Lake.

Fifty-six yellow perch and 2 walleyes were captured and radio tagged below the thermal discharge between September 10 and December 1, 1976. River temperatures dropped from 19°C to 30°C and discharge temperatures fell from 27°C to 12°C. Forty-eight perch were tracked successfully. Thirty-two of these 48 perch moved upstream and encountered the mixing zone. Only 1 fish visited the discharge bay and it for only 1 day prior to moving into thermally unaltered areas of Jay Gould Lake. The remaining 31 individuals moved into thermally unmodified areas of Jay Gould Lake, Little Jay Gould Lake, Pokegama Lake and the Mississippi River above the confluence with discharge waters, or returned downstream below the mixing zone. Figure 26 depicts river temperature and the autumn 1976 perch movement upstream as a percent of the total number of perch transmitting downstream from the confluence of the discharge and Mississippi River on a given day. The greatest upstream movement occurred between October 13 and November 3, with a peak of 29% (2 of 7 individuals) occurring on October 16. At this time downstream river temperatures were dropping rapidly, relative to other Autumn periods. The only perch that entered the discharge area during the fall of 1976 moved upstream into the discharge bay during this period.

Two 1976 walleyes which were tagged below the discharge moved into the discharge bay within a day of release. Subsequently, 1 of these fish moved between discharge and thermally unaltered areas. The other moved upstream to the same 3.5 m deep bend in the river channel that walleye no. 1814 had occupied the previous fall.

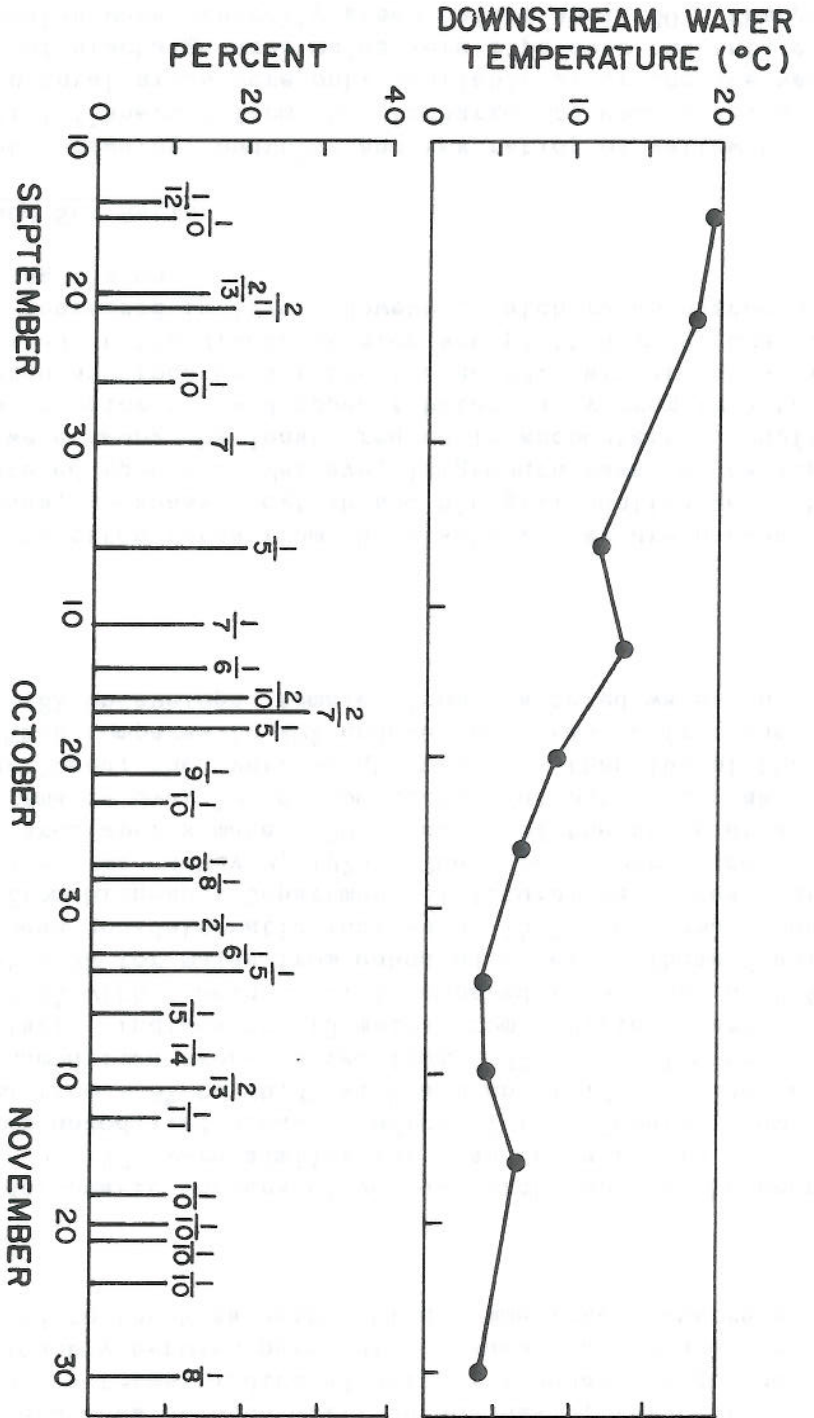

Figure 26. Autumn 1976 Downstream River Temperature (°C).  
 Autumn 1976 yellow perch moving upstream as a percent of the total number of radio tagged perch monitored downstream from the discharge area each day.



Yellow Perch Length and Weight

Length and weight observations from yellow perch captured in commercial fishing operations between April 30 and May 5, 1975, are presented in Table 15. A t-test indicated neither standard length nor weight varied significantly between perch of the same sex captured in the discharge area compared to the Mississippi River immediately upstream.

Gonadosomatic Indices

Pre-spawning gonadosomatic indices of yellow perch captured between April 7, 1975 and May 5, 1975 were similar for fish collected in thermally modified and unmodified areas. Indices for 20 females from modified areas ranged from 2.8% to 26.3% with a mean of 17.7%. Indices for 27 females from unmodified areas ranged from 1.7% to 23.3% with a mean of 16.8%. Similarly, indices for 13 males from modified areas ranged from 0.8% to 5.3% with a mean of 2.5% compared to a range of 0.4% to 3.7% and a mean of 1.9% for males from unheated waters. These figures compared closely to mean gonadosomatic indices of 16.2% for female and 3.9% for male perch from Minnesota Department of Natural Resources traps at Little Cutfoot Sioux Lake on May 9, 1975. These perch were from a thermally unmodified area approximately 50 km north of the study area. Eighteen percent of females over 150 g from Little Cutfoot Sioux Lake were considered undeveloped; the ovary weight was less than 10% of the whole body weight. This compares to 20% undeveloped females from the discharge area and 14.8% undeveloped females from unaltered waters near the discharge.

Winter Trap Netting

Winter trap netting catch rates from the discharge bay are presented in Table 16. Bullheads, rockbass, dogfish and bluegill sunfish were the most commonly encountered species. Walleye, largemouth bass, white fish, tullibee and burbot were among the least frequently encountered. Dogfish and bluegill sunfish trapping rates dropped substantially from 1975 to 1976 while yellow perch and rock bass rates increased. Winter and spring yellow perch catch rates in the discharge area are plotted in Figure 27. Catch per trap night increased in 1976. However, catch rates peaked both years near the spawning season.

Spawning Condition and Sex Ratios

Figure 28 presents spawning condition and sex ratios of yellow perch collected by commercial fishermen from the discharge and unmodified areas in 1975. Data from natural areas were only available after the ice was out. A high percent of discharge area males were ripe over the entire spawning period. Females were generally green before April 30. Changes

Table 15. YELLOW PERCH STANDARD LENGTH AND WEIGHT OBSERVATIONS, APRIL 30, TO MAY 5, 1975

	Unmodified Areas				Thermally Altered Areas			
	Female Weight (g)	Female Length (cm)	Male Weight (g)	Male Length (cm)	Female Weight (g)	Female Length (cm)	Male Weight (g)	Male Length (cm)
Mean	299	21.9	197	19.6	289	22.3	176	19.3
No. Observations	77	76	23	25	36	35	19	22
Standard Deviation	87	2.0	64	1.8	77	2.0	62	1.9





Figure 27. Yellow perch catch per trap night in discharge area for 1975 and 1976.

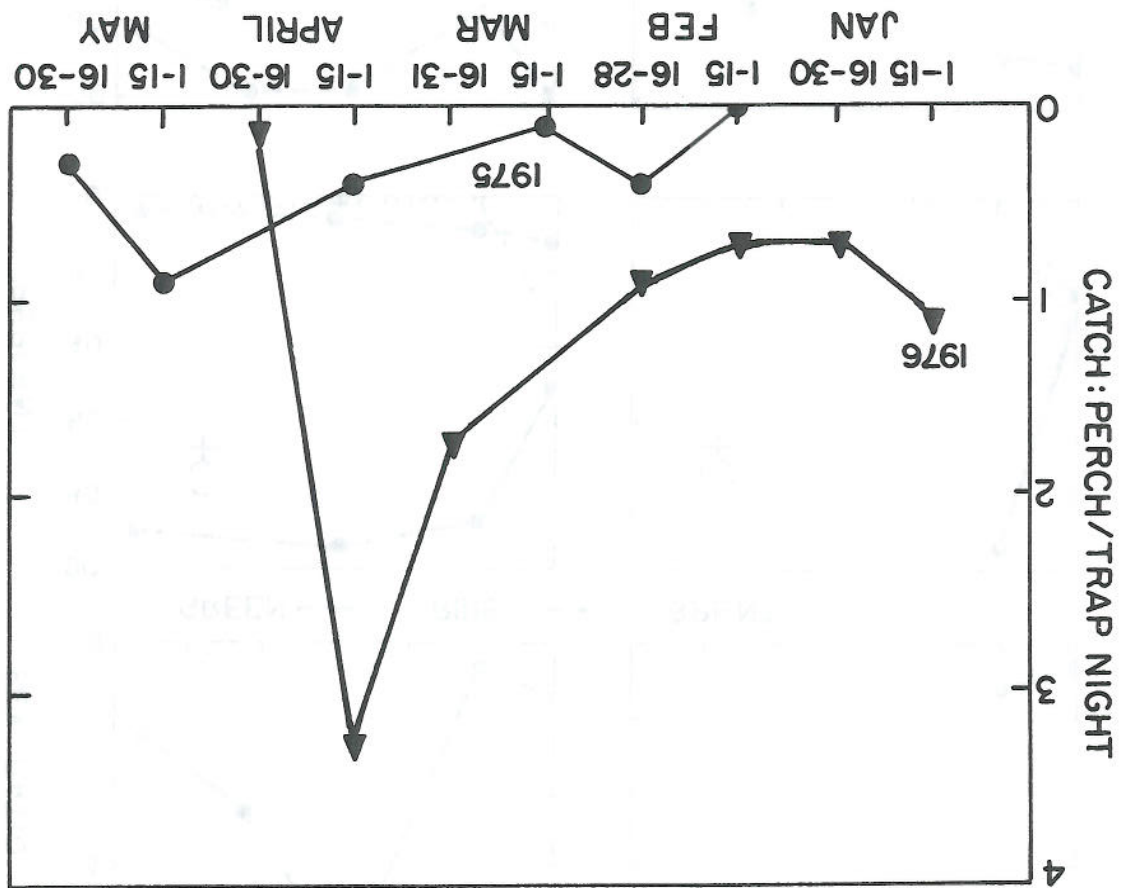
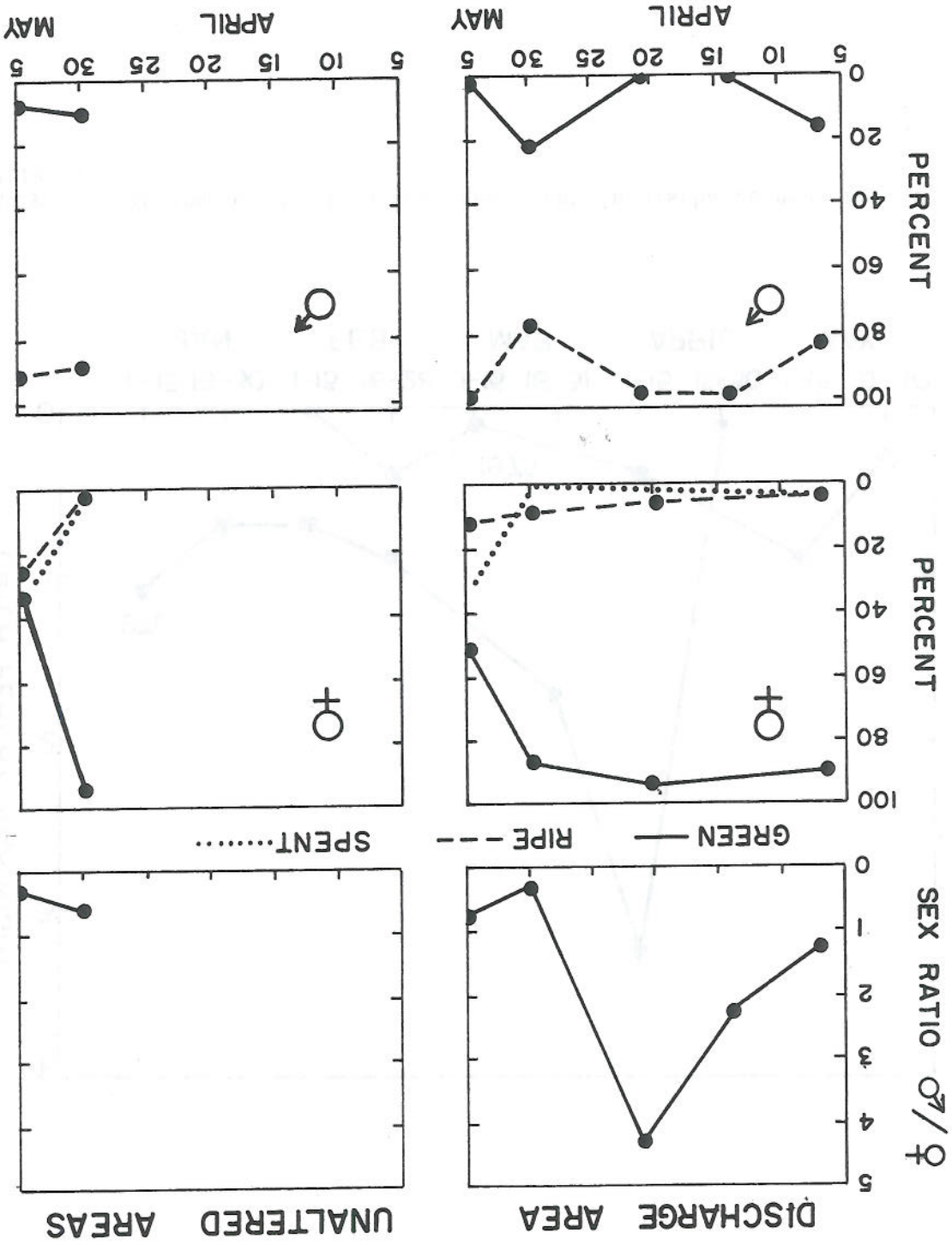

Figure 28. Sex ratios and spawning condition of yellow perch from discharge and unaltered areas 1975.



Angler returns of Atkins tagged fish provided insight into long term movement. A yellow perch tagged in the discharge bay December 10, 1975 was caught 7.2 km upstream in the Mississippi River during the summer of 1976. Another perch tagged 0.8 km above the discharge on May 3, 1975 was caught June 24, 1976 6.2 km further upstream. A yellow perch tagged April 21, 1975 in the discharge bay was caught 6 km downstream below the Pokegama Dam on June 18, 1975. Angler returns of 2 walleyes showed even further long term movement. A 312 g walleye tagged 0.8 km above the discharge on May 3, 1975 was caught approximately 16 km further upstream on October 12, 1975. A 1.59 kg walleye tagged December 2, 1975 in the discharge bay was caught 7.2 km downstream, below the Pokegama Dam on July 9, 1976.

While trawling downstream from the mixing zone during the fall of 1976 a yellow perch Atkins tagged in the discharge bay the previous winter was collected.

The recapture of both radio and Atkins tagged fish provided valuable information (Table 17). Recapture rates for radio tagged fish were similar to Atkins tagged individuals. Nine radio tagged yellow perch recaptured in nets had an average of 11 other perch of various sizes in the same net. Ten recaptured transmitter tagged perch were in good condition with no debris or vegetation entangled with the transmitter. Transmitter and backing washers generally remained firmly attached and little, if any, abrasion was noted around the transmitter or attachment washer. One female tagged prior to spawning and recaptured 45 days later had released its eggs. The peak of spawning also occurred during this time period. A radio tagged walleye recaptured after 166 days had abrasions and lesions near the anterior end of the attachment backing washer. A radio tagged northern pike recaptured 11 months after tagging appeared to be in good condition. The skin under both the transmitter and attachment backing washer had abrasions, but there was no obvious infection. This 5.67 kg female had maintained its weight over the 11 month period.

Recaptures

in sex ratios indicated that males moved into spawning areas in the discharge by April 21, followed shortly thereafter by females. The peak of spawning occurred between April 30 and shortly after May 5, 1975 in both discharge and unmodified areas. Similar data were not available for electrofishing in both modified and unaltered areas were spent. Also after April 19 catch rates in discharge area nets dropped to 0.1 perch/trap night. They had been 3.3 from April 1 to 6, 1976. For the same time intervals catch rates in unaltered areas climbed from 6 to 9.4 perch/trap night, apparently indicating that perch were leaving the discharge area for unaltered waters.



Table 17. YELLOW PERCH RECAPTURE DATA

	No. <u>Tagged</u>	<u>Returns</u>			<u>Total Percent Return</u>
		<u>Netting</u>	<u>Electro-fishing</u>	<u>Angling</u>	
62 Radio	116	9	1	1	9.5%
Atkins	903	61	3	5	7.7%

## SECTION 7

### DISCUSSION

Habitat selection is a complex and dynamic process. The habitat a fish selects is influenced by many variables including light, temperature, depth, ice cover, dissolved and suspended chemicals, vegetation, predators, prey and competition. Furthermore, the relative importance of each parameter may vary with species, time of day, weather patterns, season, and environmental alterations. This study evaluated the comparative impact of an industrial perturbation on the habitat selection of yellow perch and three other fishes as determined by distribution and temperature selection.

The telemetry results indicated that each species reacted differently. With the exception of largemouth bass, the thermal experience appeared to be transitory. Temperature most likely played a relatively minor role in the autumn, winter and early spring habitat selection of yellow perch. Habitat selection of northern pike was also found little if at all effected. Additionally, observations on recaptured animals suggested that neither radio tagging nor handling adversely affected behavior or survival.

The nature of telemetry studies limits researchers to making numerous observations on relatively few animals. An implicit assumption is that tagged animals behave similarly to the remainder of the population. Our tagged perch indicated that activity and survival of radio tagged fish were similar to perch marked with standard fisheries methods. Due to size limitations of the radio transmitter, we usually tagged large perch that were almost always female. However, the fact that an average of 11 other yellow perch of various sizes were in the same net with 9 recaptured perch suggested that large radio tagged females were not segregated from the other portions of the yellow perch population. Finally, observations on recaptured fish indicated that radio tagged fish suffered limited physical injury due to externally applied radio transmitters. Appendix A more fully discusses the impact of radio transmitters on small fish. Although limited data are available, it appears that properly applied small radio transmitters do not interfere with short term fish behavior of the nature involved in this study during the cool and cold water seasons of the year.



Our observations that largemouth bass had a small home range entirely within the discharge area in shallow relatively warm water compare favorably with those in the literature. Winter (1977) determined that 95% of the largemouth bass locations were less than 3 m deep during the summer in an unaltered Minnesota lake. Relative to yellow perch and walleye, largemouth bass were reported to have the highest final temperature preferendum (Coutant, 1975). Clugston (1973) found largemouth bass moving in and out of a thermal discharge; however, minimum ambient water temperatures in his study were  $11^{\circ} \pm 2^{\circ}\text{C}$ , considerably warmer than the  $0^{\circ}\text{C}$  temperatures found in our study area. Largemouth bass movement rates reported by Clugston (1973) and Peterson (1976) were higher than the winter rates we found, but our determinations were a minimum daily rate because fish were not tracked continuously.

Walleyes tagged in the thermal discharge were found either to confine most of their winter movements to the deeper cooler areas of the discharge or to leave the discharge areas shortly after tagging. Little data exist in the literature concerning the effect of thermal discharges on walleye behavior. However, Holt et al. (1977) found that the mean depths in which walleyes were found in an unaltered lake was 2.8 to 7.2 m. This agrees well with the depth selection of the only walleye we monitored in the discharge area for an extended period. Both localized short term activity (Kelso 1976a) and rapid movement between areas (Bahr 1977) have been observed for walleyes. Perhaps the relatively small amount of area greater than 3 m deep in the discharge bay limited the number of walleyes that remained in the discharge bay during winter months. These fish exhibited localized activity confined to the center, deeper areas. Other walleyes left the discharge area rapidly for thermally unaltered waters.

Apparently temperature preference did not substantially influence habitat selection in the 5 walleyes tracked during autumn months. Individuals moved between altered and unaltered waters. The only site specificity observed was a large bend in the meandering river channel approximately 2.5 km above the discharge confluence with the river.

As with walleyes little information is available concerning northern pike behavior near thermal discharges. However, the relatively high amount of movement, large home range and shallow depth selection of northern pike agree with the winter observations of Diana et al. (1977) for a thermally unmodified area. They noted that pike were generally found in near shore areas less than 4 m deep. Also, this species did not develop a well defined home range; daily movements ranged from 0 to 4000 m and 70% were more than 200 m.

Yellow perch behavior relative to thermal discharges has been studied more extensively. Our observations concur with those of Storr and Schlenker (1973) and Kelso (1976b). In general the thermal discharge had little long term effect on the behavior and distribution of yellow perch. Perhaps the key to this conclusion was the high degree of



variability noted between individual yellow perch with respect to winter temperature selection. However, many other observations supported this hypothesis. The low overall winter temperature preference, the high amounts of movement between thermally altered and unaltered areas, the transitory nature of thermal experience and the failure of yellow perch to ascend an autumn temperature gradient were all behavioral indications that factors other than or in addition to temperature preference contributed significantly to habitat selection. Similar physiological observations on perch from altered and unaltered areas with respect to length, weight, spawning condition and timing suggested that thermal effects, if any, were limited.

The scope of this investigation was confined to thermal effects. However, telemetry, trapping and field observations can potentially elucidate environmental factors other than temperature to more fully explain the observed distribution of yellow perch. Trapping data indicated higher numbers of ictalurids, centrarchids, and dogfish in the discharge bay. Perhaps competition from these more thermophilic species accounted for the lack of positive thermal response observed in yellow perch. Secondly, perch may have preferred the comparative darkness offered by ice cover during winter months when vegetation cover was at a minimum. Telemetry data indicated that northern pike, a visual feeder and major predator on yellow perch, preferred many of the same shallow areas away from the discharge point, where perch were most often located when in discharge affected areas. Spring trapping data suggested that perch moved into the relatively higher standing stock of aquatic vegetation to spawn in the discharge bay. Both trapping and telemetry observations indicated that a high percentage of these fish subsequently dispersed shortly after spawning. The observed autumn distribution and movement patterns could have been a response to the aquatic vegetation dying and washing away in the narrow river channel downstream from the confluence with the thermal discharge. Perch situated upstream from the discharge did not encounter as severe a loss of habitat because this area was characteristically a wide shallow environment where the river channel meandered through wild rice beds.

Behavior with respect to food and water chemistry was not evaluated; no data were gathered relative to the abundance of food organisms. While a good deal of literature is available concerning toxicity of various levels of chemicals on growth and survival, little is known of the chemical effects on fish behavior. Furthermore, a real paucity of information exists relative to the synergistic effects of temperature and various water chemistry parameters on fish behavior. Therefore, the chance that power plant induced alterations in water chemistry could account for the lack of positive thermal response remains a possibility until further research is performed.

In summary thermal effects appeared to restrict walleye movement in the discharge area and maintained conditions in shallow areas preferred by largemouth bass. Northern pike movement was not limited to nor specific for any portion of the discharge area. On a relative basis,

movement patterns of largemouth bass, walleye and northern pike were not substantially altered from those reported in the literature from thermally unaltered areas. Finally, the results indicated that an elevated temperature in conjunction with the numerous other environmental variables in a dynamic river system did not alter the distribution of yellow perch as would be predicted on the basis of laboratory temperature preference experiments. Interpretation of cause and effect data gathered independently is difficult; however, environmental factors such as competition, predation and the dynamics of suitable aquatic vegetation habitat could more fully account for the observed fall, winter, and early spring distribution of yellow perch.

## REFERENCES

- Bahr, D.M. 1977. Homing, swimming behavior, range, activity patterns and reaction to increasing water levels of walleyes (Stizostedion vitreum vitreum) as determined by radio telemetry in navigational pools 7 and 8 of the upper Mississippi River during spring 1976. M.S. Thesis University of Wisconsin - LaCrosse. 67 pp.
- Barans, C.A. and R.A. Tubb. 1973. Temperatures selected seasonally by four fishes from western Lake Erie. J. Fish. Res. Board Can. 30(11):1697-1703.
- Bennett, G.W. 1970. Management of lakes and ponds. Second edition. Von Nostrand Reinhold Co., New York. 375 pp.
- Brett, J.R. 1956. Some principles in the thermal requirements of fishes. Quart. Rev. Biol. 31(2):75-87.
- Brungs, W.A. and B.R. Jones. 1977. Temperature criteria for freshwater fish: protocol and procedures. U.S.EPA Ecol. Res. Ser. EPA 600/3-77-061.
- Clugston, J.P. 1956. Some effects of heated effluents from a nuclear reactor on species diversity, abundance, reproduction and movement of fish. Ph.D. Thesis. University of Georgia. 104 pp.
- Cochran, W.W. and R.D. Lord, Jr. 1963. A radio-tracking system for wild animals. J. Wildl. Manage. 27(1):9-25.
- Coutant, C.C. 1969. Thermal pollution - biological effects. In: A review of the 1968 literature on wastewater and water pollution control. J. Water Poll. Contr. Fed. 41(6):1036-1053.
- Coutant, C.C. 1970. Thermal pollution - biological effects. In: A review of the 1969 literature on wastewater and water pollution control. J. Water Poll. Contr. Fed. 42(6):1025-1057.
- Coutant, C.C., 1975. Temperature selection of fish - a factor in power plant impact assessments. Symposium on the physical and biological effects on the environment of cooling systems and thermal discharges at nuclear power stations. IAEA-SM-187/11. Oslo, 26-30 August 1974.



- Coutant, C.C. and C.P. Goodyear. 1972. Thermal effects - reviews. In: 1971 water pollution control literature review. J. Water Poll. Contr. Fed. 44(6):1250-1294.
- Coutant, C.C., and H.A. Pfuderer. 1973. Thermal effects - a review of the literature of 1972 on waste water pollution control. J. Water Poll. Contr. Fed. 45(6):1331-1369.
- Coutant, C.C., and H.A. Pfuderer. 1974. Thermal effects. J. Water Poll. Contr. Fed. 46(6):1476-1540.
- Diana, J.S., W.C. Mackay and M. Ehrman. Movements and habitat preference of northern pike (Esox lucius) in Lac Ste. Anne, Alberta. Trans. Am. Fish. Soc. 106(6):560-565.
- Dobie, J. 1966. Food and feeding habits of the walleye Stizostedion v. vitreum, and associated game and forage fishes in Lake Vermillion, Minnesota, with special reference to the tullibee, Coregonus (Leucichthys) artedi. Minn. Fish. Invest. No. 4:39-71.
- Eriksson, L.O. MS. 1974. Diel and seasonal activity rhythms and vertical distribution in the perch, Perca fluviatilis at the Arctic Circle. Ms. Report, Univ. Umea, Sweden. 10 p. + 2 Tab. and 6 Fig.
- Ferguson, R.E. 1958. The preferred temperature of fish and their midsummer distribution in temperate lakes and streams. J. Fish. Res. Board. Can. 15(4):607-624.
- Gibbons, J.W., J.F. Hook and D.L. Forney. 1972. Winter responses of largemouth bass to heated effluent from a nuclear reactor. The Progressive Fish Culturist. 34(2):88-90.
- Hayne, D.W. 1949. Calculation of size of home range. J. Mammal. 30(1):1-18.
- Hokanson, K.E.F. 1977. Temperature requirements of some percids and adaptations to the seasonal temperature cycle. J. Fish. Res. Board Can. 34(10):1524-1550.
- Holdaway, J.A. 1967. Temperature and aquatic life. Lab. Invest. No. 6. Fed. Water Poll. Contr. Adm. Cincinnati, Ohio.
- Holt, C.S., G.D.S. Grant, G.P. Oberstar, C.C. Oakes, and D.W. Bradt. 1977. Movement of walleye, Stizostedion vitreum, in Lake Bemidji, Minnesota, as determined by radio-biotelemetry. Trans. Am. Fish. Soc. 106(2):163-169.
- Jones, B.R., K.E.F. Hokanson, and J.H. McCormick. 1977. Winter temperature requirements for maturation and spawning of yellow perch Perca flavescens (Mitchell). (In) Towards a plan of actions for mankind, Proc. World Conf., Vol. 3.: Biological Balance and Thermal Modifications M. Marios (Ed.). 189-192.

- Kelso, J.R.M. 1976a. Diel movement of walleye Stizostedion vitreum vitreum, in West Blue Lake, Manitoba, as determined by ultrasonic tracking. J. Fish. Res. Bd. Can. 33:3070-3072.
- Kelso, J.R.M. 1976b. Movement of yellow perch (Perca flavescens) and white sucker (Catostomus commersoni) in a nearshore Great Lakes habitat subject to a thermal discharge. J. Fish. Res. Bd. CAN. 33:42-53.
- Maloney, J.E. and F.H. Johnson. 1957. Life histories and interrelationships of walleye and yellow perch, especially during their first summer, in two Minnesota lakes. Trans. Am. Fish. Soc. 85:191-202.
- Marcy, D.B. Jr., and R.C. Galvin 1973. Winter-spring sport fishery in the heated discharge of a nuclear power plant. J. Fish. Biol. 5:541-547.
- McCauley, R.W. 1977. Seasonal effects on temperature preference in yellow perch, Perca flavescens. U.S. EPA Ecol. Res. Ser. EPA 600/3-77-088.
- Minnesota Power and Light Co. 1977. (MP&L 1977). 316(a) Demonstration in support of Minnesota Power and Light Company's application for alternative thermal effluent limitation, Clay Boswell S.E.S. 30 W. Superior St., Duluth, MN.
- Odum, E.P. and E.J. Kuenzler. 1955. Measurement of territory and home range size in birds, Auk. 72(2):128-137.
- Peterson, A.R. 1962. A biological reconnaissance of the upper Mississippi River. Minn. Dept. Cons. Invest. Rpt. No. 255.
- Peterson, D.C. 1976. Black basses tracked in a Tennessee reservoir. Underwater telemetry newsletter 6(1):1-4.
- Scott, W.B. and E.J. Crossman. 1973. Freshwater fishes of Canada. Bulletin 184. Fish. Res. Board Can. 966 p.
- Seaburg, K.E. and J.B. Moyle. 1964. Feeding habits, digestive rates and growth of some Minnesota warm water fishes. Trans. Am. Fish. Soc. 93(3):267-285.
- Siniff, D.B. and J.R. Tester. 1965. Computer analysis of animal movement data obtained by telemetry. Bioscience 15(2):104-108.
- Storr, J.F. and G. Schlenker. 1973. Response of perch and their forage to thermal discharges in Lake Ontario. Proc. of Symp. Thermal Ecology, Augusta, Georgia, May 3-5, 1973.

- U.S. Dept. of the Interior. 1957. A special report on the Mississippi River Headwater reservoir system. Bureau of Sport Fisheries and Wildlife. Mpls., MN.
- Warden, R.L. Jr. and W.L. Lorio. 1975. Movements of largemouth bass (Micropterus salmoides) in impounded waters as determined by underwater telemetry. Trans. Am. Fish. Soc. 104(4):696-702.
- Winter, J.D. 1976. Movements and behavior of largemouth bass (Micropterus salmoides) and steelhead (Salmo gairdneri) determined by radio telemetry. Ph.D. Thesis. Univ. of Minn. 195 pp.
- Winter, J.D. 1977. Summer home range and habitat use by four largemouth bass in Mary Lake, Minnesota. Trans. Am. Fish. Soc. 106(4):323-330.
- Winter, J.D., V.B. Kuechle, D.B. Siniff and J.R. Tester. 1978. Equipment and methods for radio tracking freshwater fish. Univ. of Minn. Inst. of Ag. Misc. Bul. 152. 45 p.



## APPENDIX A

### STUDIES TO DETERMINE THE EFFECT OF RADIO TRANSMITTERS ON YELLOW PERCH (Perca flavescens) AND LARGEMOUTH BASS (Micropterus salmoides)

Radio and ultrasonic telemetry have been utilized extensively to monitor movements, activity, and reactions of both free-ranging and captive animals to environmental variables. While terrestrial biologists have the opportunity to locate and visually observe their study animals, fisheries researchers rarely have the same opportunity. Because behavioral characteristics of tagged specimens are studied for the purpose of extrapolation to non-tagged individuals, the effect of the tag and tagging process must be known before such extrapolation can be made with confidence.

Transmitter attachment procedures have differed among telemetry studies depending on the species, environment, type of research, and state of the art. Winter (1976) and Morris (1976) discussed various internal and external attachment methods and the respective advantages and problems associated with each. Several authors, including Bahr (1977), Hart and Summerfelt (1975), Henderson et al. (1966), Warden and Lorio (1975), Winter (1977), Young et al. (1972), and Ziebell (1973) have discussed the effect of transmitters on fish relative to one or more of the following: swimming ability, feeding behavior, survival, and tag retention. Although there is a good deal of indirect information as to the effect of transmitters on fish, much of it is subjective or derived from short term observations. Furthermore, even less is known concerning physiological effects and the effects of package weight.

Laboratory studies indicate that both physostomes and physoclists can re-adjust their buoyancy to neutral after radio tagging. Fried et al. (1976) reported that by gulping air, Atlantic salmon smolts (Salmo salar) adjusted for negative buoyancy induced by transmitter tag weight. Neutral buoyancy was regained in physoclistic fish in less than 24 hours by secreting gas into the air bladder to adjust for transmitter weight (Gallepp and Magnuson 1972). However, McCleave and Stred (1975) determined that larger internal and external tags caused a significant decrement in swimming ability in stamina chambers. Wrenn and Hackney (1976), using dummy radio transmitters surgically implanted in sauger (Stizostedion canadense) concluded that some mortality could be expected, but that long-term growth and general condition of fish that survive would not be affected. However, further investigations of this nature are warranted as the state of the art of electronics for telemetry has surpassed our knowledge of the bio-effects of transmitter packages.

This paper reports on several studies which have been carried out to determine the effect of the radio transmitter package on behavior, physiology, and predator-prey relationships on yellow perch and largemouth bass. These studies were conducted in laboratory situations and others were done in large outdoor ponds.

## Methods

Five studies were conducted to evaluate radio package effects. The general design of these studies was to contrast the physiological and behavioral responses of control fish to those of dummy radio tagged and/or sham tagged fish when exposed to similar environmental conditions and challenges. Control groups were usually tagged with Atkin's tags (small plastic tags) attached into the upper back portion immediately anterior to the dorsal fin. Dummy radio tagged fish were also equipped with an external, simulated radio tag fitted immediately ventral of the dorsal fin. Dummy radio tags were designed to weigh approximately 1% of the fish's weight. Sham tagged individuals were processed identically to the dummy tagged fish except that after processing the tag was removed and the experiment carried on. The 5 experiments were as follows: (1) survival of dummy radio tagged versus control yellow perch; (2) some more subtle effects of transmitter attachment as measured via differential mortalities between dummy radio tagged and untagged fish when exposed to predation by northern pike; (3) feeding rates of control and dummy radio tagged largemouth bass; (4) respiration, feeding, and growth rates of control, sham tagged and dummy tagged yellow perch; and (5) the influence of different tag weight to yellow perch weight to determine the maximum load carrying capacity.

### (1) Survival

Equal numbers of dummy radio tagged and Atkin's tagged perch were released into a 0.5 ha, 2 m deep pond at the EPA Environmental Research Laboratory Duluth, Minnesota. The study pond bottom was gravel with several inches of silt and submerged vegetation although the shallows supported growths of filamentous algae. Substantial amounts of planktonic algae were noted throughout the summer. Temperatures in the pond averaged 22°C at the surface and 19°C at the bottom. Dissolved oxygen in the pond was very low at the bottom, averaging 1.4 parts per million in August and reaching a low of 0.1 part per million early in the month. Fish were picked in an unbiased manner for assignment into the transmitter and control group. Tagged and control fish were released on 3 different occasions during August, 1975.

### (2) Predation

The predation experiment was carried out in an adjacent small pond about 0.05 ha in area and 1 m deep. The bottom was bedrock and gravel with very little silt and about 70 percent was covered with dense aquatic vegetation. The water was very clear throughout the experiment and no major algal blooms were observed. Temperature averaged 20.5°C. Because of the shallow depth, dissolved oxygen, though not measured, was assumed to be near saturation. In this case 66 yellow perch were used as prey species and 5 northern pike (Esox lucius) were used as the predator. On 3 different occasions during August and September 1975 equal numbers of dummy tagged and control yellow perch were released into



this pond. Shoreline observations of the pond were made about every 2 days for mortality and the pond was seined twice during the experiment. It was completely drained on September 12, 1975 and all surviving fish were sacrificed for examination. The northern pike stomachs were examined for evidence of predation.

### (3) Feeding - Largemouth Bass

The feeding experiment with largemouth bass was carried out in the Duluth Environmental Research Laboratory. Ten laboratory reared and 12 wild-caught largemouth bass were divided equally among a dummy tagged group and a control group. After tagging, all fish were given a Terramycin treatment and during the next nine days given two formalin and one Roccal treatment. Fish were fed a measured amount of minnows once every other day from September 8 through September 13. The fish were allowed to feed for alternately 1-hour and 6-hour periods with the remaining minnows removed from the tanks after these time limits.

### (4) Respiration, Feeding and Growth

Further experiments on yellow perch measuring respiration rates, feeding rates, and growth were carried out at our field laboratory in Cohasset, Minnesota from September 28, 1976 to November 7, 1976. The fish were kept in a 600 liter stainless steel holding tank supplied with untreated Mississippi River water. The temperature in the tank varied with the river temperature. The fish were divided into 3 separate groups consisting of control, dummy radio tagged, and sham-tagged fish with five individuals in each group. Each individual was weighed and measured prior to and after the 6-week experiment. Each group was supplied with 10 minnows each day and the number consumed was tallied the following day. The respiration rate of each fish was counted daily using the number of operculum cycles for a 30-second interval. Notes on survival and tag retention were kept throughout the experiment.

### (5) Maximum Loading

The maximum dummy radio tag weight an individual could carry was determined for 5 yellow perch. Fish were equipped with small dummy radio tags and the weight of the tag increased by adding brass washers and nuts to protruding bolts until the individual could no longer maintain equilibrium or swim normally in a holding tank.

## Results

### (1) Survival

When the 0.5 ha pond was drained on November 1 (86 days after initial release), only 2 of 28 dummy radio-tagged fish were recovered while 23 of 28 controls survived (Table A-1). Between August 11 and September 10, 9 dead dummy tagged fish and 2 dead control fish were found in the pond. Four of the 9 dummy tagged fish had enlarged holes around the attachment wires, and filamentous algae caught between the fish and the anterior end of the tag. One of the observed mortalities was a dummy-tagged fish that had lost its tag. The holes were evident where the tag had pulled through the body and the dorsal fin.

### (2) Predation experiment

Table A-2, summarizes the results of the predation experiment. Observed mortalities were subtracted from the total fish released to obtain the number of fish available to predators. Twenty-nine out of 31 control fish were recovered and 11 out of 27 tagged fish were recovered. Dummy radio tagged fish had a significantly higher mortality rate ( $P < 0.001$ ). Mortalities cannot be confirmed as due entirely to predation, but that predation was at least partially involved was evidenced when on capture the largest pike regurgitated a partially digested dummy radio tagged perch. When the 0.05 ha. pond was drained, 5 dummy radio tags were found on the bottom with no tissue attached. One had been seen several days earlier on a living perch. The stomach of another pike yielded a radio tag with a small amount of tissue still attached, suggesting that the other tags retrieved from the bottom of the pond may have represented egesta of previous prey fish.

### (3) Largemouth bass feeding experiment

Figure A-1 summarizes the results of the feeding experiment. For the laboratory fish, controls consumed more minnows than radio-tagged fish in 13 out of 13 trials. For the wild fish, controls ate more minnows than dummy tagged fish in 10 out of 13 trials. Controls seemed more active than tagged fish, but tagged fish seemed to have no difficulty in feeding and were observed feeding 12 hours after they were tagged. When the fish were examined on September 13 and November 2, sores were observed under the tag and attachment plate. Dummy radio tags had loosened during the experiment chafing the underlying surface. Some fungus was present on the tags and around the attachment wires, but there were some fungus infections on the control fish also. One tagged fish had shed its tag. The wound had healed, leaving only a slight scar and a torn section of the dorsal fin.

Table A-1. SURVIVAL RESULTS ON YELLOW PERCH (PERCA FLAVESCENS) RELEASED INTO THE LARGE POND

	<u>Atkin's Tag</u>	<u>Dummy Radio</u>
Released		
August 6, 1975	11	11
August 7, 1975	4	4
August 30, 1975	<u>13</u>	<u>13</u>
Total released	28	28
Recovered (pond drained)		
November 1, 1975	23	2
Not recovered		
Observed mortality	2	9
Unobserved mortality	<u>3</u>	<u>17</u>
Total not recovered	5	26
Percent survival	82%	7%

Table A-2. RESULTS OF PREDATION EXPERIMENT

	<u>Control</u>	<u>Tagged</u>
Released		
August 7, 1975	10	10
August 29, 1975	12	12
September 7, 1975	<u>9</u>	<u>9</u>
Total	31	31
Observed mortalities (not due to predation)	<u>0</u>	<u>4</u>
Total available to predators	31	27
Recovered		
August 19, 1975	7	0
September 5, 1975	0	1
September 12, 1975	<u>22</u>	<u>10</u>
Total	29	11
Percent survival	94%	41%



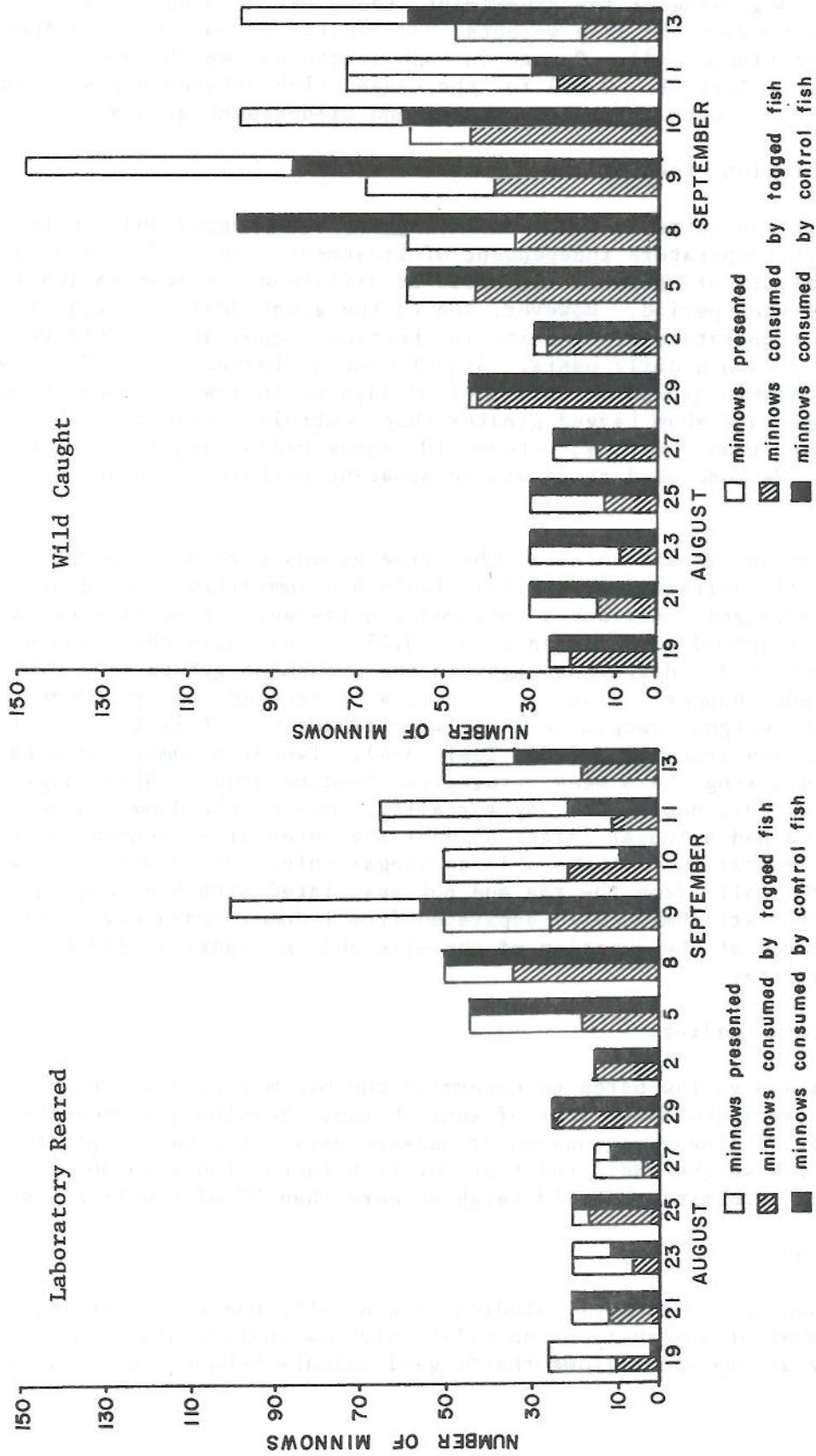

Figure A-1. Feeding of laboratory reared and wild largemouth bass under laboratory conditions.

At the beginning of the experiment, there was no significant difference between the mean weights, and lengths of controls and dummy tagged fish (Table A-3). Growth in both length and weight was significantly less ( $P < 0.05$ ) for the tagged fish between August 6 and September 13 in both laboratory reared and wild-caught groups.

#### (4) Respiration, Feeding and Growth

Respiration rates in dummy radio tagged, sham tagged and control fish varied with temperature independent of treatment (Fig. A-2). A single factor analysis of variance indicated no difference in respiration rate over the 6-week period. However, due to the great deal of variability caused by temperature fluctuation in the tank, respiration rates were also analyzed on a daily basis. Significant differences ( $P < 0.05$ ) were observed between groups on only 3 of 33 days as follows: October 6, dummy radio tagged and sham tagged greater than controls; October 7, sham tagged lower than controls; October 10, dummy radio tagged lower than controls. We concluded there was no apparent pattern in these differences.

Feeding and growth rates in the three groups were not found to be significantly different ( $P < 0.05$ ), Table A-4 summarizes the results. While sham-tagged individuals consumed considerably fewer minnows, a Chi square test showed no difference ( $P < 0.05$ ). Initially there was no significant weight difference between the treatment groups ( $P < 0.05$ ). While weight changes did not occur similarly between the treatment groups, the weight changes were not significantly different from initial weights in any group ( $P < 0.05$ , Table A-4). Two of 6 dummy radio tagged perch died during the 6 week respiration-feeding study. Sham-tagged and control fish did not suffer any mortality. One of the dummy radio tag mortalities had a fungal infection near the anterior attachment site. The other mortality also had a large fungal infection, however, it was located ventrally from the tag and not associated with the tagging site. The anterior attachment wire separated from 1 dummy radio tag. This break occurred at the junction of the wire and the epoxy shield covering the transmitter.

#### (5) Maximum Loading

We used 5 yellow perch to determine the maximum package weight that could be carried without loss of equilibrium. Results are presented in Table A-5. A linear regression of package weight (in water) plotted against fish weight indicated that for fish in the 140 g to 300 g size range, the transmitter should weigh no more than 2% of the fish's weight.

### Discussion

The nature of telemetry studies is generally one of collecting a large number of observations on relatively few individuals. The necessary assumption follows that tagged animals behave similarly to the

Table A-3. A COMPARISON OF WEIGHT, AND LENGTH OF LARGEMOUTH BASS BEFORE AND AFTER THE FEEDING EXPERIMENT (NUMBER OF FISH EXAMINED IN PARENTHESES)

Date		Lab Reared Group		Wild Group	
		Control (5)	Tagged (5)	Control (6)	Tagged (6)
8/6/75	Average weight (g)	364.9	410.8	211.3	288.5
	Range	277-506	335-549	131-287	84-439
	Standard deviation	97.2	81.0	64.2	118.5
	Average total length (cm)	28.3	29-1	24.2	24.6
	Range	26-31	28-32	21-27	18-30
	Standard deviation	2.2	1.8	2.4	3.9
8/13/75	Average weight (g)	450.9	432.4	250.8	227.6
	Range	282-639	321-611	178-324	99-435
	Standard deviation	138.9	109.7	56.2	113.7
	Average total length (cm)	29.5	29.6	25.3	24.7
	Range	27-33	28-33	22-28	19-30
	Standard deviation	2.7	1.9	2.2	3.8
	Change in weight (g)	+ 86.0	+ 21.6	+ 39.5	- 0.9
	Change in length (cm)	+ 1.3	+ 0.5	+ 1.1	+ 0.1



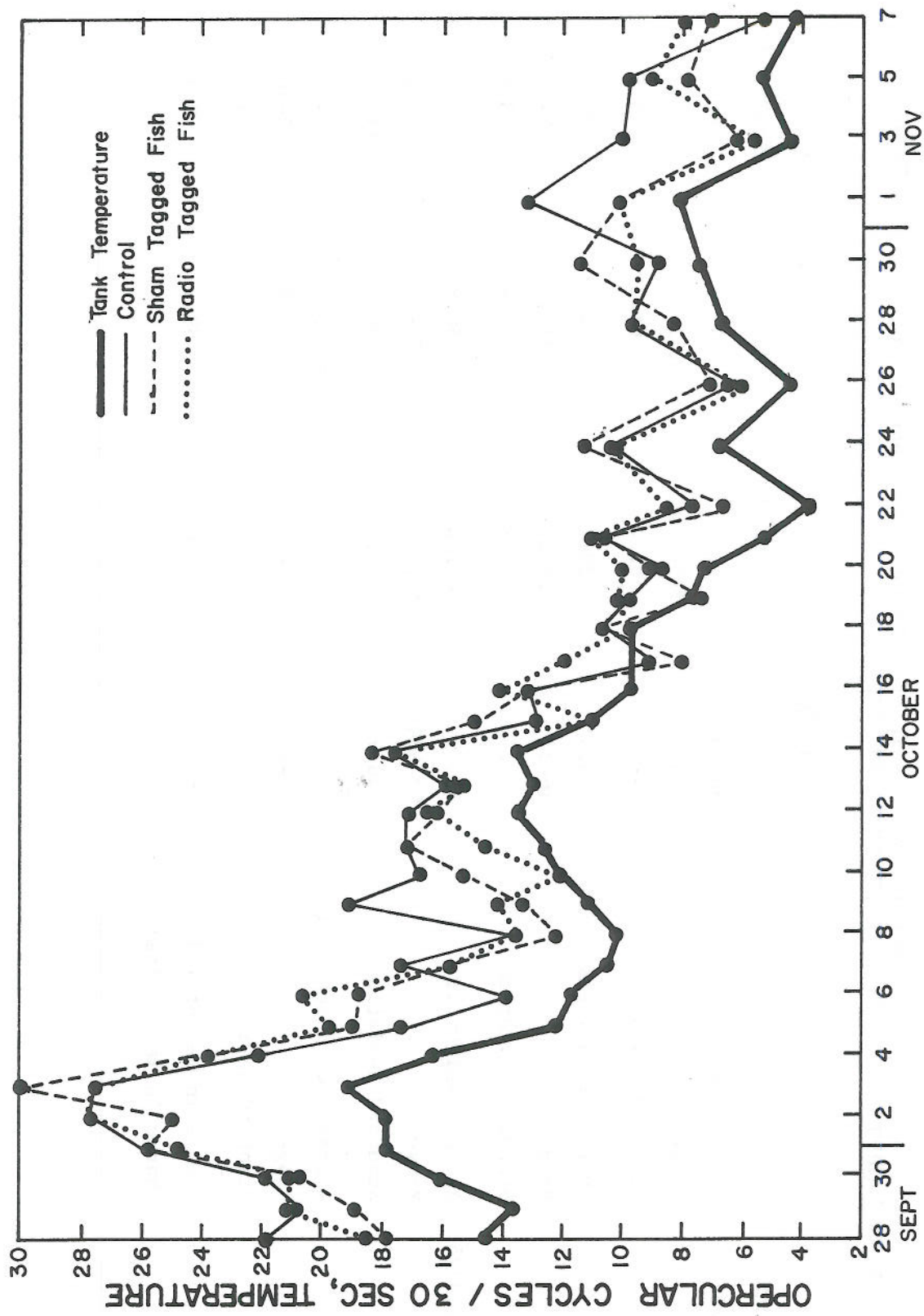

Figure A-2. Tank temperature and respiration rates of control, sham tagged, and dummy radio tagged perch.

Table A-4. YELLOW PERCH FEEDING AND GROWTH. SEPTEMBER 28 TO NOVEMBER 11, 1976.

	<u>Number Minnows Consumed</u>	<u>Mean Initial Weight (g)</u>	<u>Mean Final Weight (g)</u>	<u>Mean Weight Change %</u>
Dummy radio	53	245	251	+ 2%
Sham tag	25	270	245	- 9%
Control	55	263	249	- 5%

Table A-5. MAXIMUM WEIGHT OF TAG RESULTING IN LOSS OF EQUILIBRIUM AMONG YELLOW PERCH OF DIFFERENT SIZES

<u>Fish Weight (g)</u>	<u>Tag Weight (g)</u>	<u>Tag Weight in Water (g)</u>	<u>Tag Weight in Water as Percent of Fish Weight</u>
142	5.1	3.3	2.4%
218	5.1	3.3	1.7%
283	7.5	5.3	1.9%
283	10.5	7.0	2.5%
283	10.5	7.0	2.5%

rest of the population. These studies contrasting the responses of dummy radio tagged fish to those of untagged fish revealed that the basic assumption upon which radio telemetry studies is founded may be accepted with reservations. These reservations point to the essential need to know that the answers to the questions being asked are not biased by the processes of capturing, tagging and carrying the transmitter package. The bioeffects of an external transmitter were revealed in these studies to be composed of several elements. One was a weight element, where transmitter (weight in water) burdens greater than 2% of fish weight were found excessive.

Low dissolved oxygen concentrations in addition to the trauma of handling and tagging contributed to the high incidence of mortality in large pond survival study, indicating that radio tagged fish are more susceptible to environmental stresses that compound tagging effects. Survival was also compromised by entanglement of external transmitters in dense aquatic vegetation. Survival of radio-tagged fish appears to be much greater under more favorable conditions. Studies with yellow perch in the upper Mississippi have resulted in a 9.6% recapture rate of 115 radio-tagged perch, compared to a 7.7% recapture rate of 903 Atkins-tagged perch (Ross, 1978). Furthermore, the recaptured radio-tagged perch had an average of 11 other non-tagged individuals in the same net. Haynes (1978) reported that 47% of radio-tagged chinook salmon (Oncorhynchus tshawytscha) reached Lower Graithe Dam on the Snake River, compared to 33% of controls. Indirectly, the effect of the radio tag appears no greater than that of standard fisheries tags.

Virtually every telemetry study involving more than a very few individuals can anticipate some mortality. Mortality rates may be increased due to handling and tagging. These studies revealed that survival may be decreased due to selective predation on radio tagged fish. The problem facing the researcher is to account for these eventualities in experimental design and ensure that telemetry data differentiates between moribund or dead and normally active individuals. Generally moribund individuals can be detected simply by their lack of movement. Thus the data from such immobile individuals can be removed prior to analysis.

Laboratory experiments indicated that yellow perch respiration rates, growth and feeding behavior were not altered by dummy tags. While respiration rates varied with temperature, little difference was observed among control, sham tagged and dummy tagged fish. This implies to us that tagged fish were not required to alter their metabolic rates in order to carry the transmitter. Also, the lack of variation among groups over changing temperatures indicated a similar physiological response to this environmental variable. However, the largemouth bass study found feeding and growth to be nearly always greater among non-tagged fish. These findings may indicate a species specific response or merely that at the lower temperatures in the perch experiment more time may have been required to detect statistically significant differences.



In spite of the problems revealed in these studies radio telemetry may be the best or the only means available to answer some types of questions. In these cases it is essential to know of the shortcomings and to take them into consideration when interpreting the findings. However, many very important ecological questions can apparently be addressed by this technology without any or with only slight technology induced bias. The Mississippi River mark and recapture studies (Ross, 1978) produced overnight fyke net catches of both tagged and non-tagged perch, suggesting that they move in the same areas and essentially in the same time frame. Further these catches produced nearly equal percentage recapture ratios between actual radio tagged fish and Atkin's tagged fish. These findings also indicate that in the less restricted natural environment during the cooler months, differential mortalities between tagged and non-tagged groups may not be as serious as suggested by our pond studies. Both of these findings give support to the primary premise that at least gross movements of tagged fish are representative of those of non-tagged fish.

### References

- Bahr, D.M., 1977. Homing, swimming behavior, range, activity patterns and reaction to increasing water levels of walleye (Stizostedion vitreum vitreum) as determined by radio telemetry in navigation pools 7 and 8 of the upper Mississippi River during spring 1976. M.S. Thesis, University of Wisconsin - La Crosse, 67 p.
- Freid, S.M., J.D. McCleave, and K.A. Stred, 1976. Buoyancy compensation by Atlantic salmon (Salmo salar) smolts tagged internally with dummy telemetry transmitters. J. Fish. Res. Board Can. 33:1377-1380.
- Gallepp, G.W., and J.J. Magnuson. 1972. Effects of negative buoyancy on the behavior of the bluegill, (Lepomis macrochirus) Rafinesque. Trans. Am. Fish. Soc. 101(3):507-512.
- Hart, L.G. and R.C. Sumerfelt, 1975. Surgical procedures for implanting ultrasonic transmitters into flathead catfish (Pylodictus olivaris). Trans. Am. Fish. Soc. 104(1):56-59.
- Haynes, J.M. 1978. Movement and habitat studies of chinook salmon and white sturgeon. Ph.D. thesis, Univ. of Minn. 166 p.
- Henderson, H.R., A.D. Hasler, and G.G. Chipman, 1966. An ultrasonic transmitter for use in studies of movements of fishes. Trans. Am. Fish. Soc. 95(4):350-563.
- McCleave, J.D., and K.A. Stred, 1975. Effect of dummy telemetry transmitters on stamina of Atlantic salmon (Salmo salar) smolts. J. Fish. Res. Board Can. 33(4):559-563.
- Morris, W.K., 1976. Evaluation of methods of attaching simulated ultrasonic transmitters to adult male walleye (Stizostedion vitreum vitreum) (Mitchell). Proposal of Masters thesis. University of Oklahoma Norman, Oklahoma.
- Ross, M.J. 1978. Winter distribution of fish and temperature preference of yellow perch (Perca flavescens) in the thermal plume of a power plant as determined by radio telemetry. M.S. Thesis, Univ. of Minn. 127 p.
- Warden, R.L., Jr., and W.L. Lorio, 1975. Movements of largemouth bass (Micropterus salmoides) in impounded waters as determined by underwater telemetry. Trans. Am. Fish. Soc. 104(4):696-702.

- Winter, J.D. 1976. Movements and behavior of largemouth bass (Micropterus salmoides) and steelhead (Salmo gairdneri) determined by radio telemetry. Ph.D. thesis, Univ. of Minn. 197 p.
- Winter, J.D. 1977. Summer home range movements and habitat use by four largemouth bass in Mary Lake, Minnesota. Trans. Am. Fish. Soc. 106(4):323-330.
- Wrenn, W.B. and P.A. Hackney, MS 1976. Growth and survival of sauger (Stizostedion canadense) with surgically implanted model transmitters. Biothermal Research Station, Tennessee Valley Authority. (Unpublished Manuscript).
- Young, A.H., P. Tytler, F.G.J. Holliday, and A. MacFarlene, 1972. A small sonic tag for measurement of locomotor behavior in fish. J. Fish. Biol. 4:57-65.
- Ziebell, C.D., 1973. Ultrasonic transmitters for tracking channel catfish. Prog. Fish. Cult., 35(1):28-32.



## APPENDIX B

### TEMPERATURE TRANSMITTER DESIGN AND DEVELOPMENT

Temperature sensing transmitters used in this study were developed for use on small fish and constructed by the University of Minnesota's Cedar Creek Bioelectronics Laboratory. In the development of the temperature transmitter circuit 3 areas were critical (Figure B-1). First, the pulse rate had to remain constant with changes in power supply voltage. This was especially critical when working with lithium 2.8 v batteries. By inserting  $R_{s1}$  and  $R_{s2}$  (Figure B-1), pulse rates were stabilized for changes in power supply voltage. Lithium batteries were not used in this study; however, weight and life considerations make lithium cells preferable for many aquatic applications and will be utilized extensively when smaller sizes become available. A single 1.4 v. mercury cell (RM675) was used to power temperature transmitters used in this study. Pulse rate voltage stability of the temperature-sensing circuitry was found to be greater at this voltage eliminating the need for  $R_{s1}$  and  $R_{s2}$ . Table B-1 summarizes pulse interval variation versus changes in supply voltage.

Second, long-term drift had to be minimal so that temperature transmitters would retain their original calibration over the expected life of the unit. Figure B-2 summarizes drift testing data. Worst case drift was found to be 1°C at 0°C and generally much less. These tests were made over a ten-week period, but shorter term observations could be expected to measure temperature more accurately. Since the bulk of the drift occurred during the first two weeks of testing, long-term drift could probably be reduced by pre-aging tags before calibration.

The third design goal was to obtain a range of optimum sensitivities from 0 - 35°C. The actual pulse rate for a given temperature or range of greatest sensitivity was determined by the thermistor-timing capacitor combination. By varying this combination, the range of maximum sensitivity could be optimized (Figure B-3).

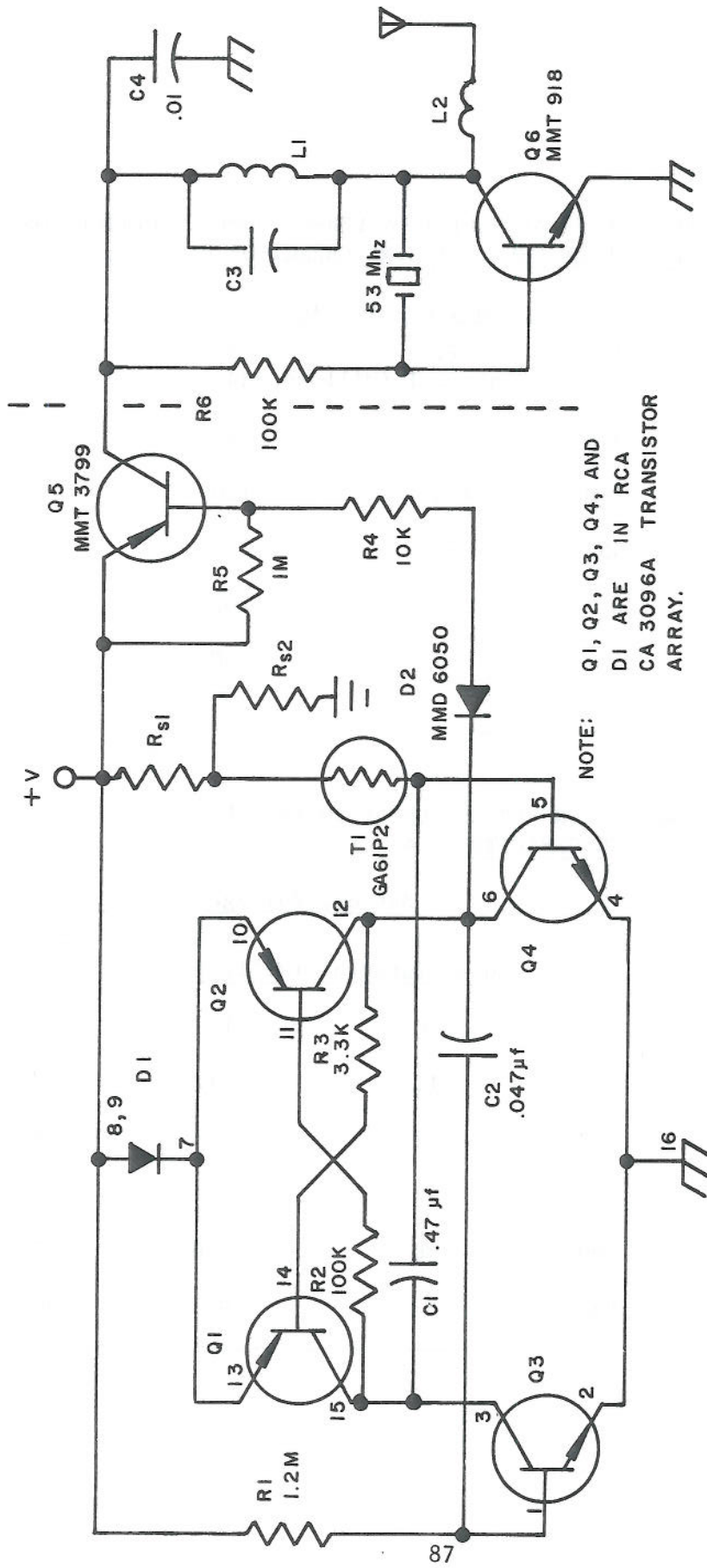

Figure B-1. Temperature transmitter circuit.

Table B-1. PULSE INTERVAL VARIATION VERSUS SUPPLY VOLTAGE FOR 2.8 VOLT NOMINAL LITHIUM CELL. TIMING CAPACITOR 0.47  $\mu$ f.

Thermistor Resistance	Battery Voltage		
	2.6	2.8	3.0
	Pulse Interval (Milliseconds)		
488 k	656	656	656
1.0 M	1110	1109	1109
1.5 M	1552	1548	1548
1.04 M	2073	2067	2063
2.5 M	2518	2510	2507

PULSE INTERVAL VARIATION VERSUS SUPPLY VOLTAGE FOR 1.25 VOLT NOMINAL MERCURY CELL. TIMING CAPACITOR 0.47  $\mu$ f.

Thermistor Resistance	Battery Voltage			
	1.2	1.3	1.4	1.5
	Pulse Interval (Milliseconds)			
470 K	158	160	162	165
680 K	210	211	212	214
1.0 M	341	342	343	346
1.5 M	472	472	472	474
2.2 M	700	700	700	700
3.3 M	983	983	983	983



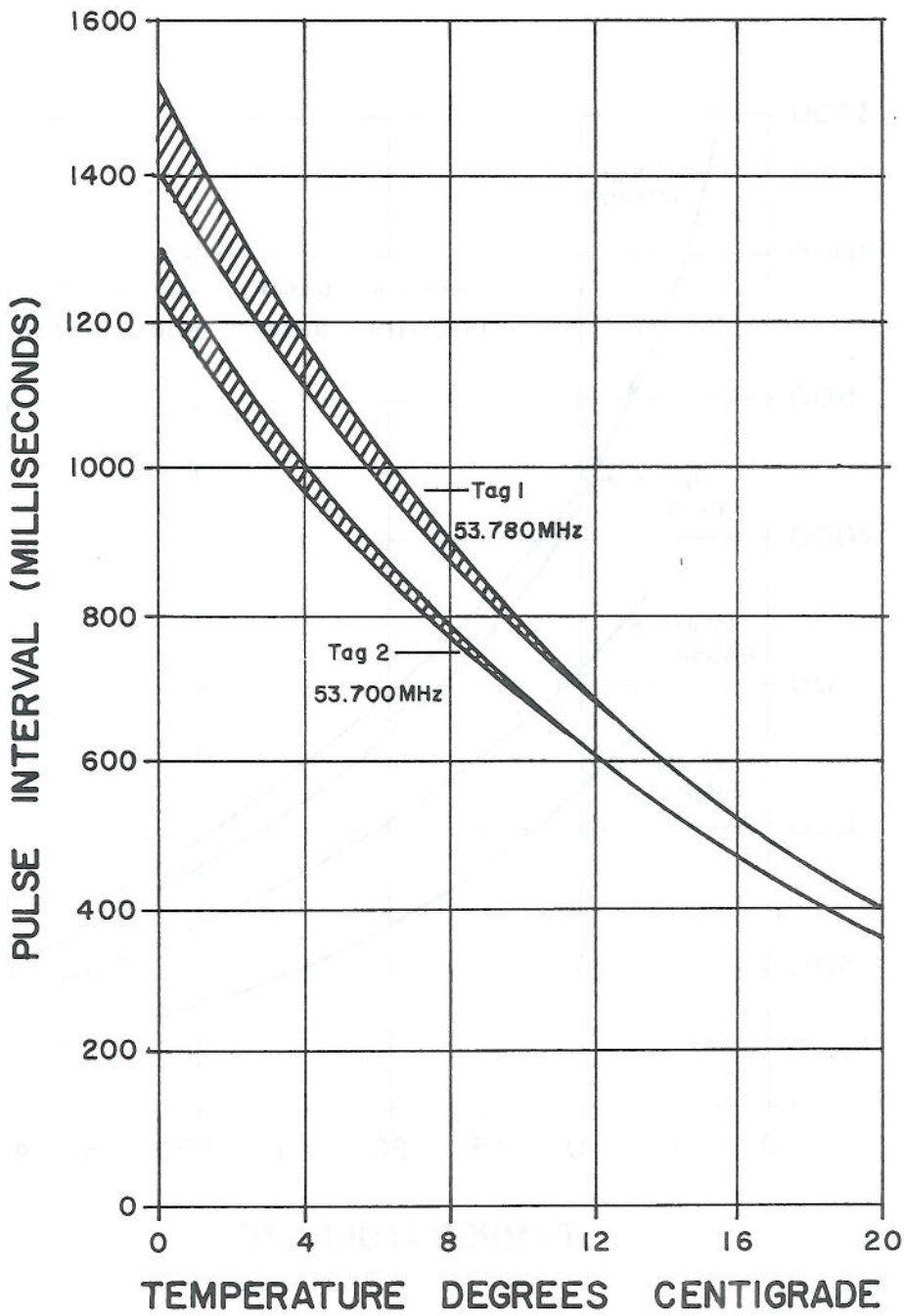

Figure B-2. Envelope of long term temperature transmitter calibration drift. Calibration checked: 10/5/76, 10/19/76, 11/2/76, 11/17/76, 12/21/76.

# PULSE RATE VS TEMPERATURE

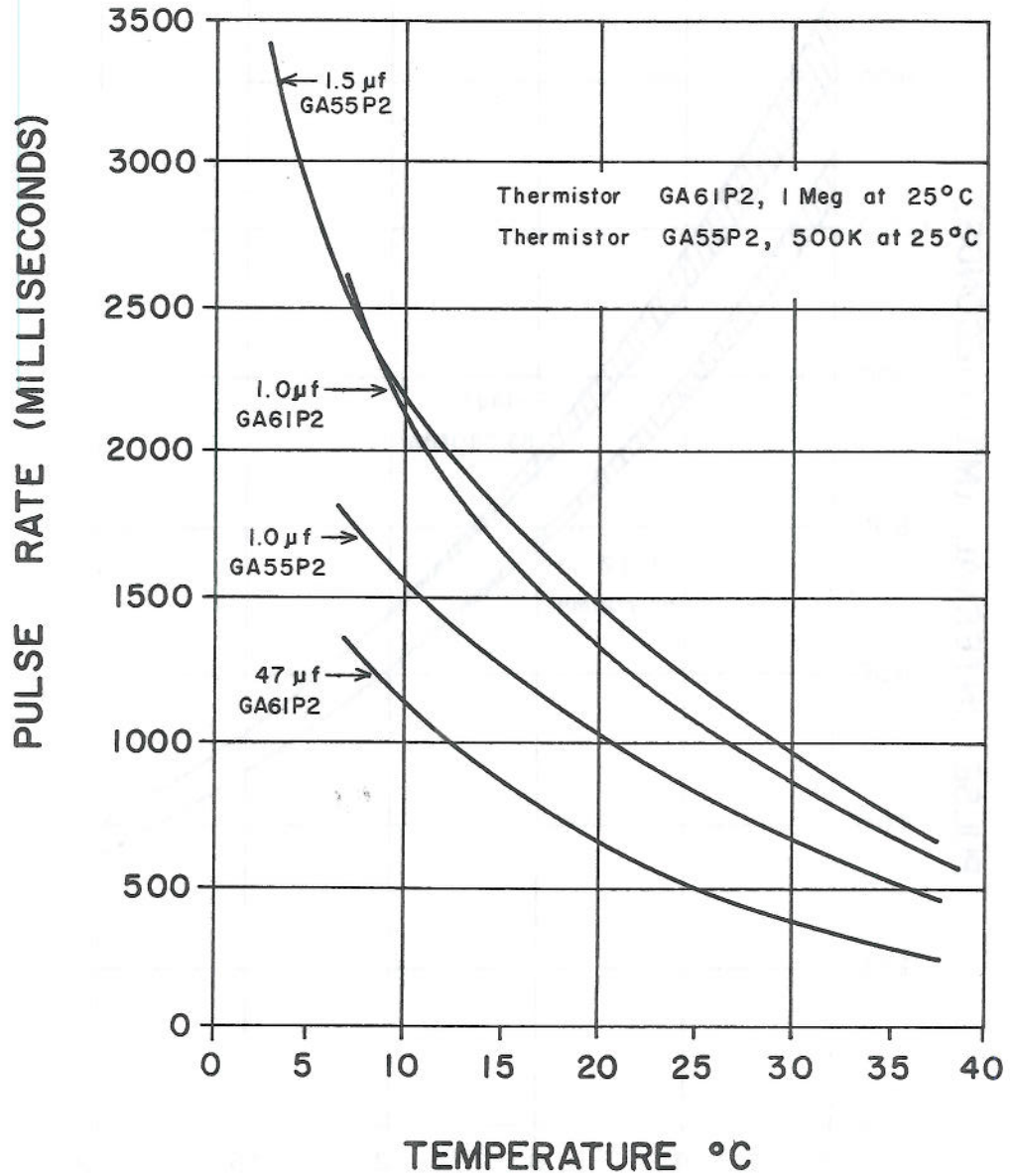

Figure B-3. Temperature transmitter pulse rate vs. Temperature, Thermistor-Capacitor combinations.

## APPENDIX C

### TECHNICAL SPECIFICATIONS FOR AUTOMATIC TEMPERATURE RECORDING EQUIPMENT

This appendix describes the automatic temperature recording system used for the project. The system had three main components; a 53 mhz programmable 16 channel scanning receiver, a pulse rate decoder and a strip chart recorder. Following a brief technical description, information on receiver controls and operating procedures is outlined. Finally, circuit and block diagrams are presented.

The receiver is similar to the model used to monitor fish location described on page 15. However, several changes and modifications were made. Major design changes included the use of a memory into which frequencies could be programmed and later recalled by means of a single selector or scanned automatically by an interval timer. This option proved valuable in 2 applications. First, in tracking from an aircraft where it is necessary to scan for a number of animals in a short period, individual animals could be tuned rapidly by means of a single switch. Since all channels are locked to a single crystal there was no need to search around a frequency to make sure that a transmitter had not been missed. A second application, and a more important one, was in unattended applications where the receiver could scan and record data from the channels that were programmed into the memory. The scanning rate could be pre-selected so that the receiver looked at 1 of 16 channels for periods ranging from 3.7s seconds to 1/2 hour. The receiver had a phase locked loop to detect the signal sent to the decoder. Use of a phase locked loop gave greater noise immunity and made transmitter drift a minor problem because the loop detects a signal if it is within  $\pm 2.5$  KHz from a set frequency.

Next, temperature transmitter signals from the receiver were sent to a pulse rate decoder. The function of this unit was to measure pulse rate and generate a signal to a recording apparatus. Since the pulses from the receiver were not perfectly square, some error would result depending on where the trigger level was set and how the pulse varied from pulse to pulse. This potential error was reduced by averaging a number of pulses. We did this in the decoder by counting the time for 10 pulses. With this scheme we were dependent only on the triggering time of the start pulse (0th pulse) and of the stop pulse (10th pulse). In addition, the error in these 2 pulses were divided by a factor of 10. Output of



the decoder was available as a digital readout from the front panel, a binary coded decimal signal and from the digital-to-analog (DA) converter. The DA converter was an 8 bit integrated circuit type with its output adjusted to 1 milliamper full scale. The 8 bit converter was capable of dividing the 0 to 1 ma scale in  $2^8$  or 256 parts.

For our application a Rustrak analog recorder was used. The milliamper current generated by the pulse rate decoder DA converter was sent to the Rustrak where it was recorded on a 3" per hour strip chart.

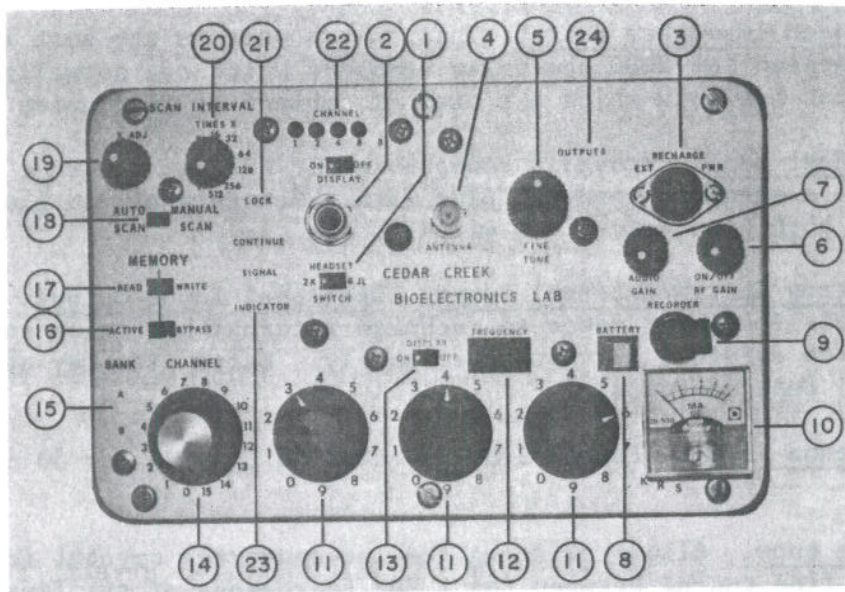

#### FRONT PANEL CONTROLS, CONNECTORS AND INDICATORS

- |  |  |
|--|--|
| (1) Headset Impedance Selector                     | (13) Display On/Off Switch                 |
| (2) Headset Jack                                   | (14) Memory Channel Selector               |
| (3) Battery Charge/External Power/Auxiliary Output | (15) Memory Bank Selector                  |
| (4) Antenna Input Connector                        | (16) Memory Active/Bypass Selector         |
| (5) Fine Tune Control                              | (17) Memory Read/Write Selector            |
| (6) On/Off RF Gain Control                         | (18) Memory Auto/Manual Selector           |
| (7) Audio Gain Control                             | (19) (20) Memory Scan Interval Control     |
| (8) Battery Status Indicator                       | (21) Signal Search Control                 |
| (9) External 0-1 ma Recorder Jack                  | (22) Auto Scan Channel Indicator           |
| (10) Signal Level Meter                            | (23) Signal Indicator From Phase Lock Loop |
| (11) Frequency Selector Switches                   | (24) Auxiliary Outputs                     |
| (12) Frequency Indicator                           |  |

## Function of Operator Controls

1. Headset Impedance Switch. This switch selects the best impedance match between the 2000 ohm Telex headsets which are normally used and the 8 ohm Koss headsets which are used if ambient or wind noise is a problem.
2. Headset Jack. Provides receptacle for headset or other listening device. A standard monaural plug fits. Standard stereo plugs may be used if both head pieces are wired to the tip.
3. Battery Charge/External Power: Operational Input/Output. Provides receptacle for input power to recharge internal batteries and to provide power from external 12 volt power supply. Extra pins may also be used as optional input-outputs.
4. Antenna Input. Female BNC connector to provide for 50 ohm antenna input.
5. Fine tune. Allows shifting the 1st converter crystal frequency to provide fine tuning between the 1 KHz increments of the frequency synthesizer. It allows the operator to tune to the frequency that can be heard best or is the most comfortable.
6. On/Off - R.F. Gain. Turns power on and off from internal batteries or external power supply. The variable resistance control varies the R.F. gain in the input pre-amplifier to prevent signal overload on strong signals. This prevents spurious signals from being generated by intermodulation and cross modulation. R.F. gain is maximum when the control is fully clockwise.
7. Audio Gain. Controls the audio level in the headset. This control has very little effect on detectability of a signal. Maximum signal level is with the control fully clockwise.
8. Battery Status Indicator. Indicates voltage level of internal rechargeable batteries or external power source. It should be in the white area for proper operation.
9. 0-1 ma External Recorder. Allows insertion of an external meter in series with the internal meter to record signal strength on an external paper recorder.
10. Signal Strength Meter. Provides an integrated indication of the audio signal level.
11. Frequency Selectors. The three switches select which frequencies are to be passed through the receiver and which are blocked. Frequency can be selected in 1 KHz increments over a 1 MHz range. The 1 MHz range is determined by selection of the preamp and first converter.



12. Frequency Indicator: Three digit display of the frequency. In the manual mode the display will be the same as the frequency selector switches (11). When in the memory active mode it will display the frequency of the active channel.
13. Display on/off Switch: Turns off the display to save power when the display is not needed.
14. Memory Channel Selector: Sixteen position switch to address which channel is to be written or read into the frequency selector.
15. Memory Bank Selector: In 32 channel receivers the switch selects channels 0-15 in position (A) or 16-31 in position (B).
16. Memory Active/Bypass Selector: This switch is used to transfer a frequency selected by front panel switches (11) into the memory channel selected by (A).
17. Memory Read/Write Selector: This switch is used to transfer a frequency selected by front panel switches (11) into the memory channel selected by (A).
18. Memory Auto Manual Selector: Selects whether the memory is to be scanned by means of the channel selector (14) or automatically by an internal timer.
- 19., 20. Memory Scan Interval Control: Controls the rate of the interval timer for the auto scan mode.
21. Signal Search Control: (Optional) With this signal in the lock mode the receiver will scan until a signal is found. It will then remain locked on that channel as long as a signal is present.
22. Auto Scan Channel Indicator: Lights indicate which channel is active in the auto scan mode. It is in binary code and can be converted to decimal by adding the number below the lights that are on.
23. Signal Indicator From Phase-locked-loop: Indicates a signal is present if the light is on.
24. Auxiliary Outputs:

## Operating Procedure

Once the function of each control is understood, operating procedure follows quite easily.

### (1)-(2) Headset Jack and Headset Impedance Switch:

The headset or other audio output device is plugged into the headset jack and the impedance switch is set to correspond to the impedance of the headset used; 8 ohms for the Koss or other stereo types or 2 K for relex or similar 2000 ohm headsets. Headsets or audio devices of other impedance can be used with some loss in output level depending on the impedance mismatch and power required. For devices other than 8 or 2000 ohms the impedance switch should be set for the best output level.

(6) On/Off R. F. Gain. The on/off switch controls the power to all modules whether the receiver is operating on external batteries or is using an external power source.

The R.F. gain control should be rotated fully clockwise so that R.F. sections are operating a maximum gain to achieve maximum sensitivity. It should be left at maximum sensitivity until the transmitter or signal source can be heard. Once the signal is found, the gain should be reduced to achieve a signal level where differences in signal amplitudes can be easily detected. The gain should also be reduced as you move toward a signal source to prevent overload of the input stages. Although overload will cause no permanent damage to the receiver, it can cause spurious signals to be generated from cross or intermodulation. These spurious signals can cause confusion. Overload (spurious signals) can cause signals to appear on channel locations where no signal sources are supposed to be. This problem usually does not occur during normal operation with perhaps 2 exceptions. 1) When attempting to determine whether a transmitter is working on the test bench extraneous signals may be detected while switching to the correct channel. Confusion may also result while attempting to check out a number of transmitters for test purposes. 2) Occasionally problems will be encountered while trying to move in on a signal source. These can almost always be cleared up by making sure the channel setting is correct for the signal source being searched and reducing the signal level. The setting of the R.F. gain control is probably the most critical for accurate and efficient signal source location.

(7) Audio Gain. The audio gain should be set for a comfortable noise level in the headset. Settling of the audio gain does not affect sensitivity except as effects hearing sensitivity. The audio level does not affect signal to noise ratio. It does affect the meter indication.



(3) - (8) Battery charge/external power; Battery level indicator. The battery level indicator should be in the white region when the receiver is turned on. If it is in the red region the internal battery voltage is low and in need of recharge or the voltage of the external power source is low. If an external power source is used, the receiver will switch automatically from internal to external power. The receiver is designed for a negative ground system. The positive supply line should be connected to pin 2 of the supply jack. If the polarities are reversed, a protective diode will block the current to prevent damage to the receiver. When external power is applied an audible click can be heard as the internal relay switches from internal to external power.

Frequency selection switches (11) control the frequency to which the receiver is tuned with the active-bypass switch (16) in the bypass position, or the read-write switch (17) in the write position. The receiver frequency will be displayed at (12) with the display switch (13) in the on position. The display draws approximately 40 ma or 1/3 of the current needed to operate the receiver. Power is saved with the display off.

The auto-manual scan switch (18) determines how the memory is addressed; by the channel switch (14) and bank switch (15), or the automatic scanning circuitry.

To program the memory, place the manual-auto scan switch (18) in the manual position. Set the channel (14) and bank (15) switches at the desired locations. Place the read-write switch (17) in the write position. Select the frequency desired with the frequency selector switches (11). Change the channel switch to the next location and select the next desired frequency. When finished programming be sure the write switch (17) is set to read. With the read-write switch in the write position the memory will record the frequency of the selector switches at the channel addressed. Manually check the channels to be sure the desired frequencies have been programmed in the memory. To change a frequency on a given channel, address the channel, place read-write switch to write, select desired frequency on selectors and switch back to read.

The channels will be scanned automatically with the auto-manual scan switch (18) in the auto position. The lights (22) indicate which channel the scanning circuitry is addressing when the channel display switch (22) is on. The time the receiver will remain on a channel is controlled by (19) and (20). The X adjust (19) controls the basic scanning rate while (20) selects a multiple of that rate. If X is adjusted to change channels every second, the multiplier (20) can change the rate up to 512 seconds. The scanning circuitry scans sequentially. The scanner does not stop scanning when the auto-manual switch is in the manual position; the memory, however, is addressed by the channel and bank switches.

Memory is retained when the receiver is off by a small internal power source. This power source should last at least one year.



# RECEIVER FUNCTIONAL BLOCK DIAGRAM

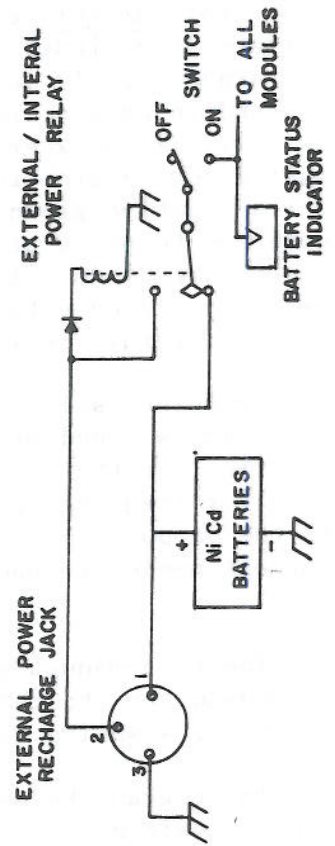
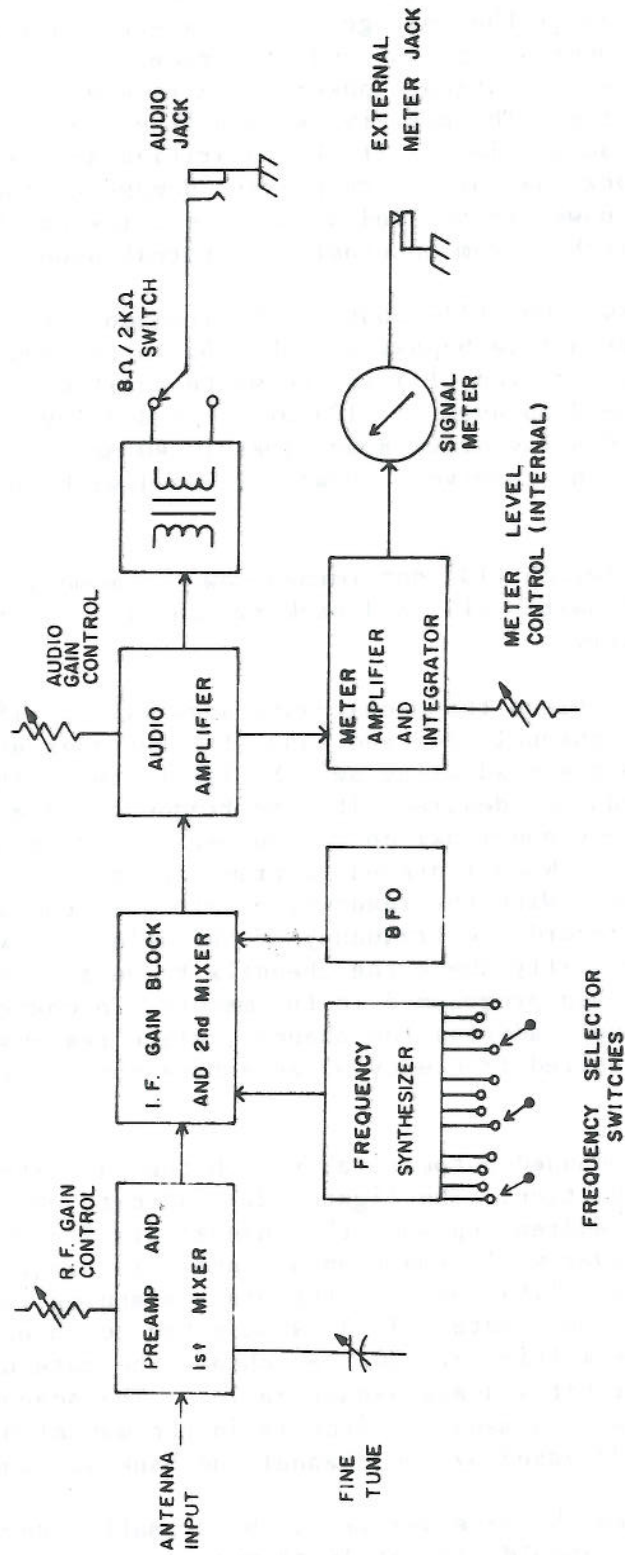

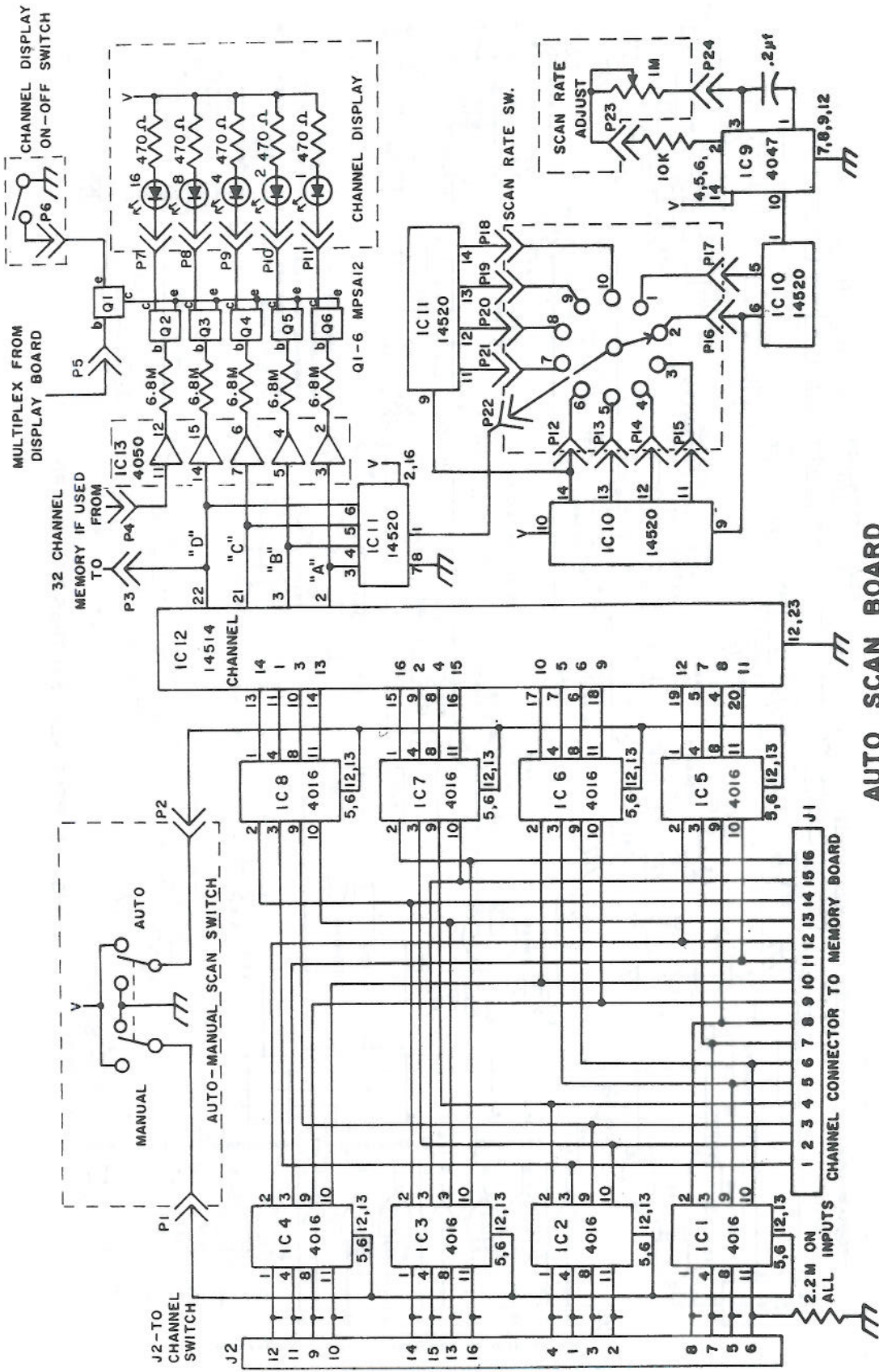

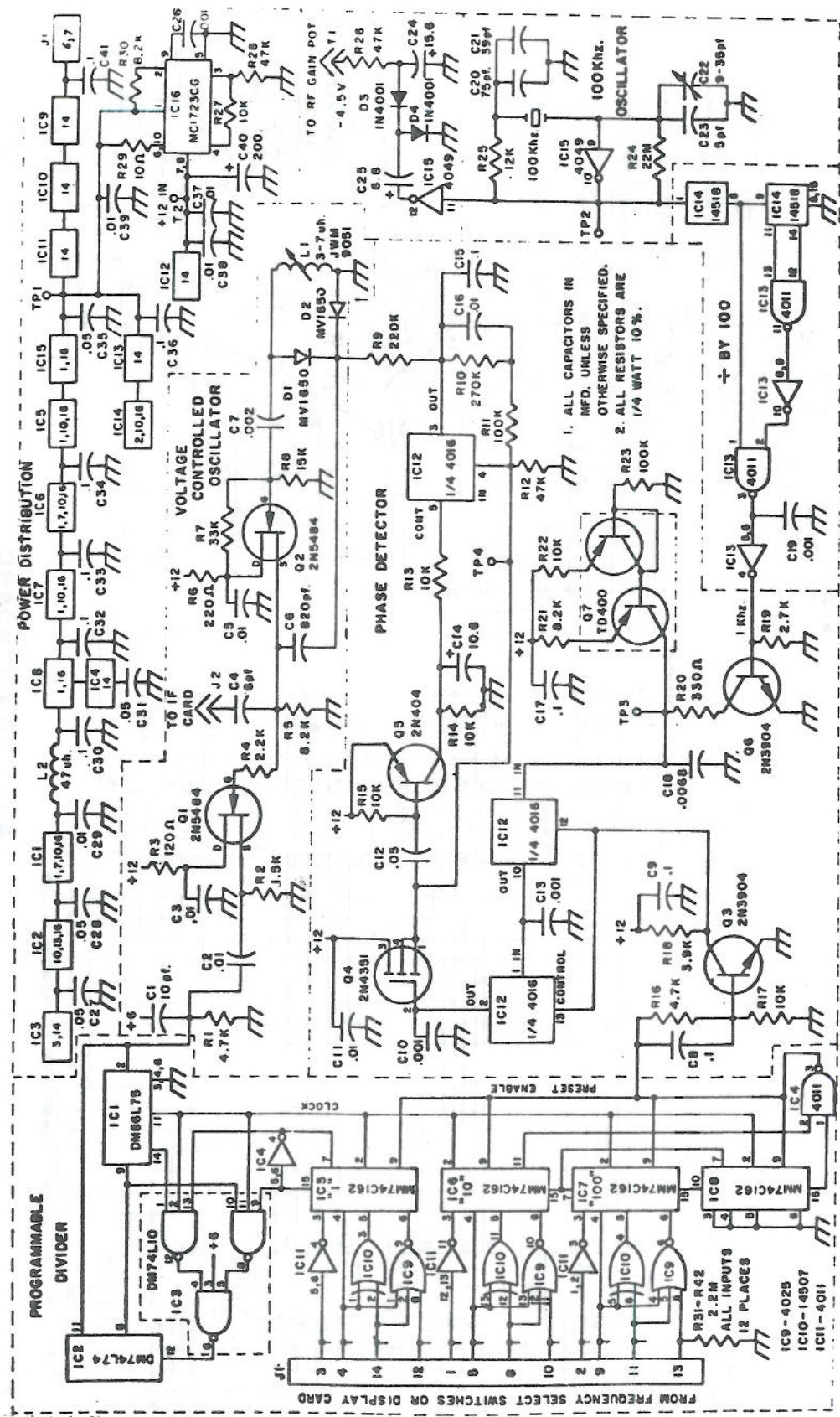

FIG 1-5 RECEIVER SYNTHESIZER BOARD



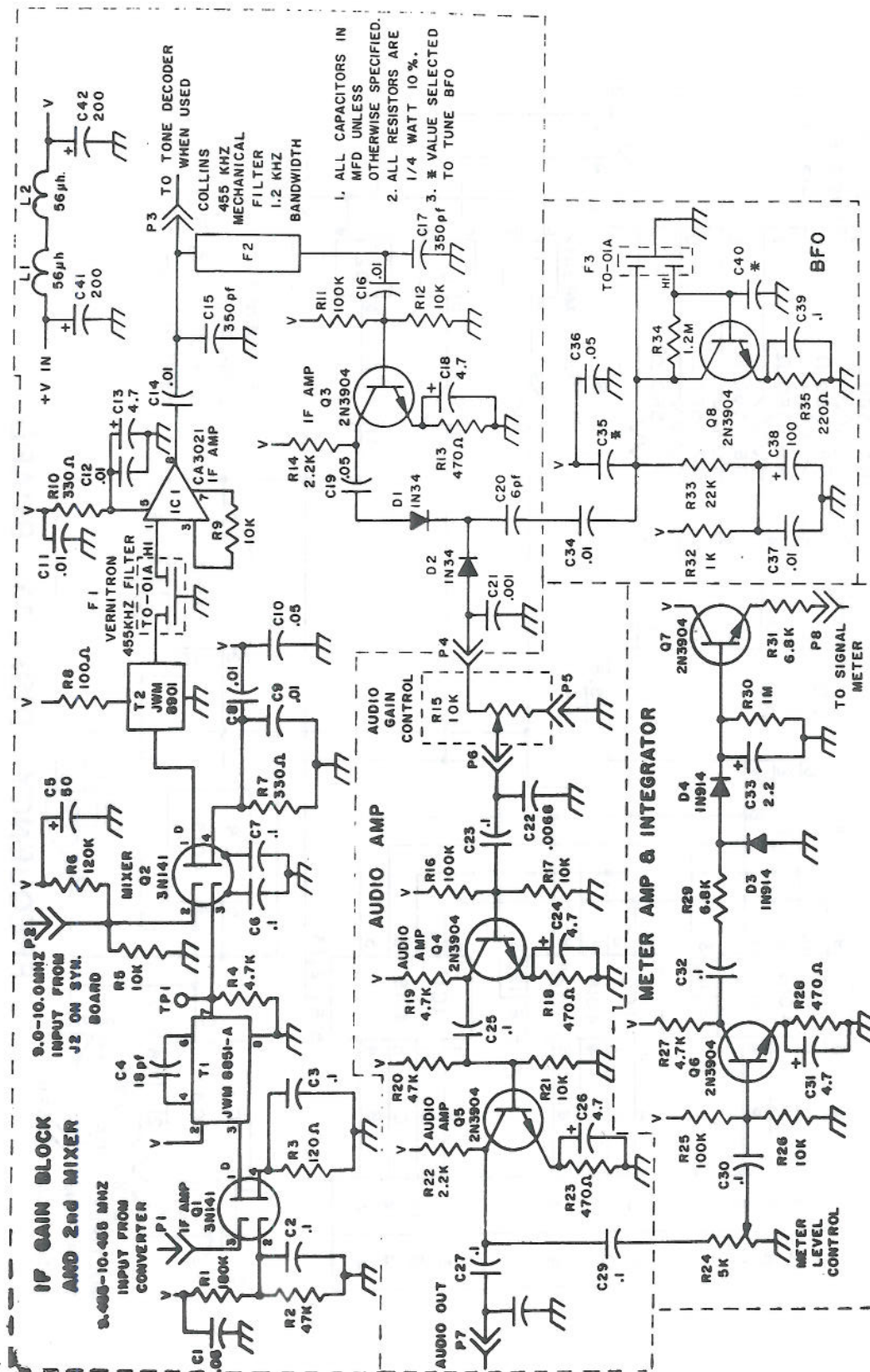
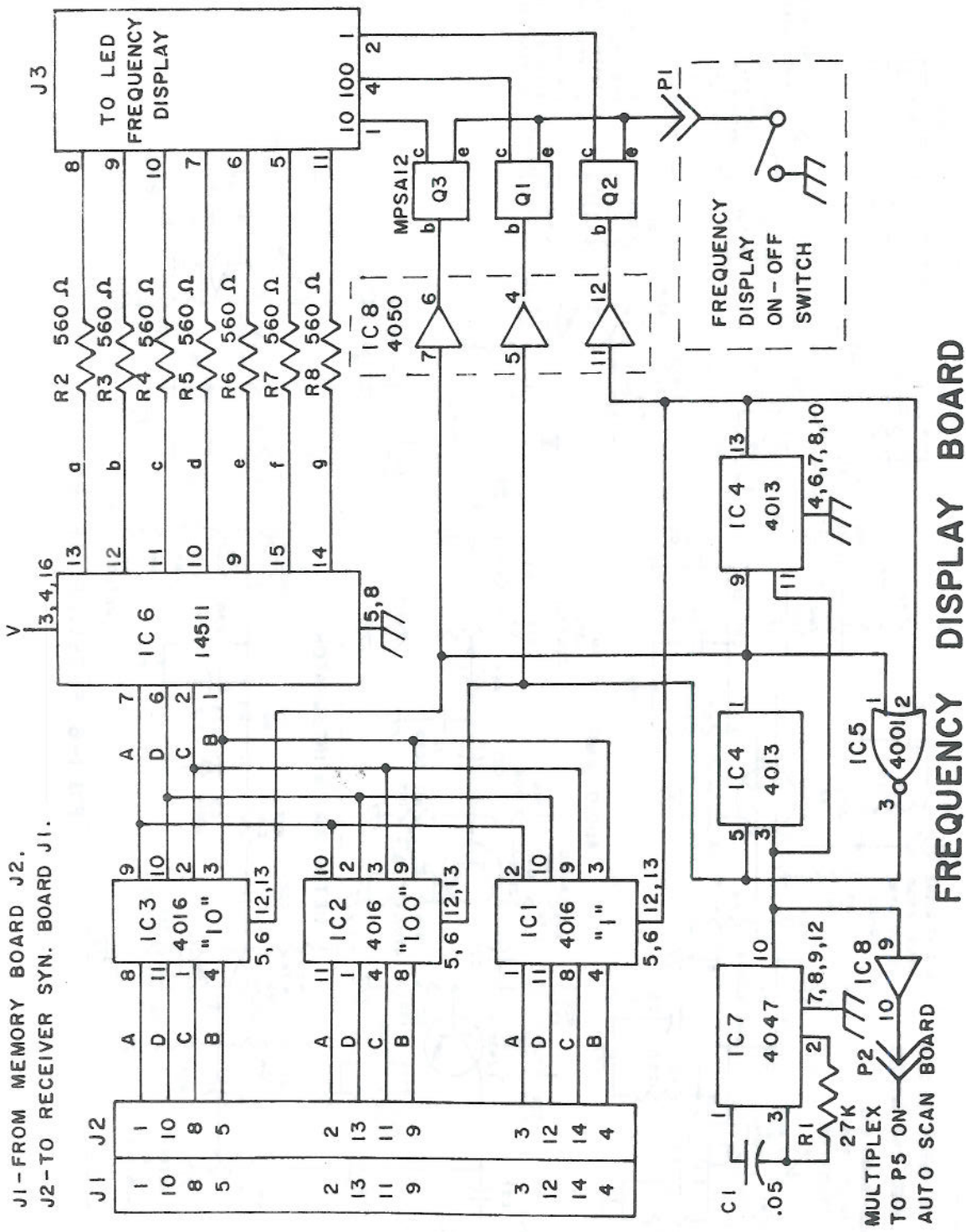
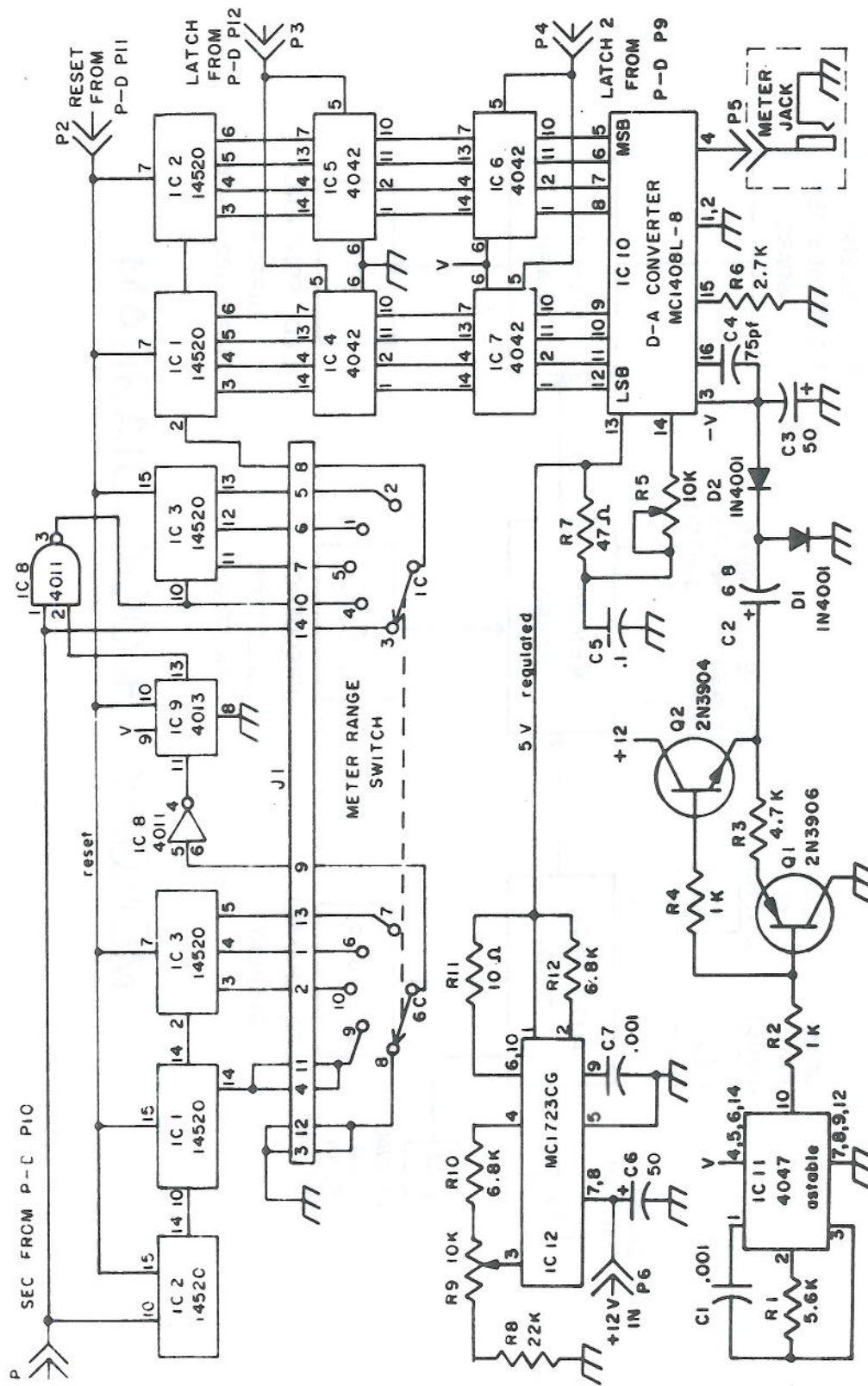

FIG 1-6 RECEIVER IF BOARD





DIGITAL ANALOG CONVERTER BOARD



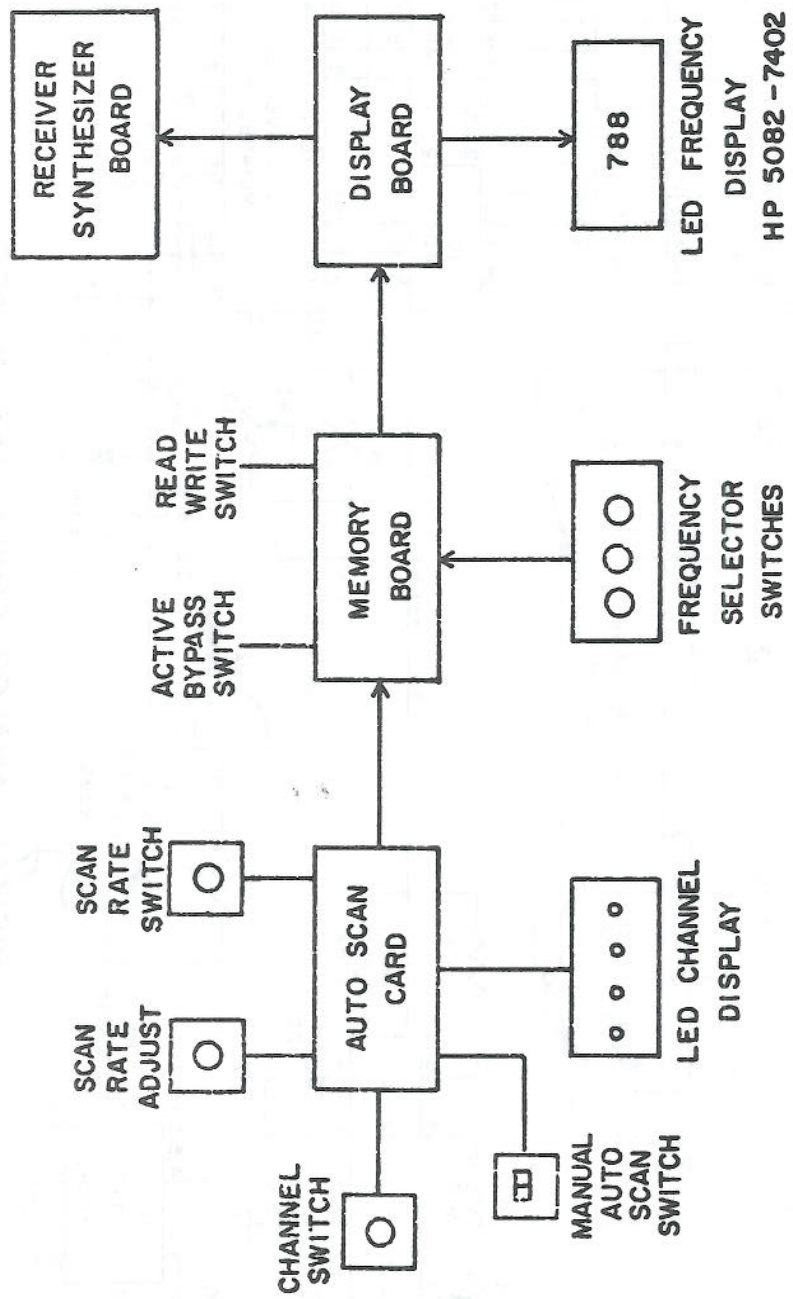

# MEMORY BLOCK DIAGRAM

HP 5082-7402

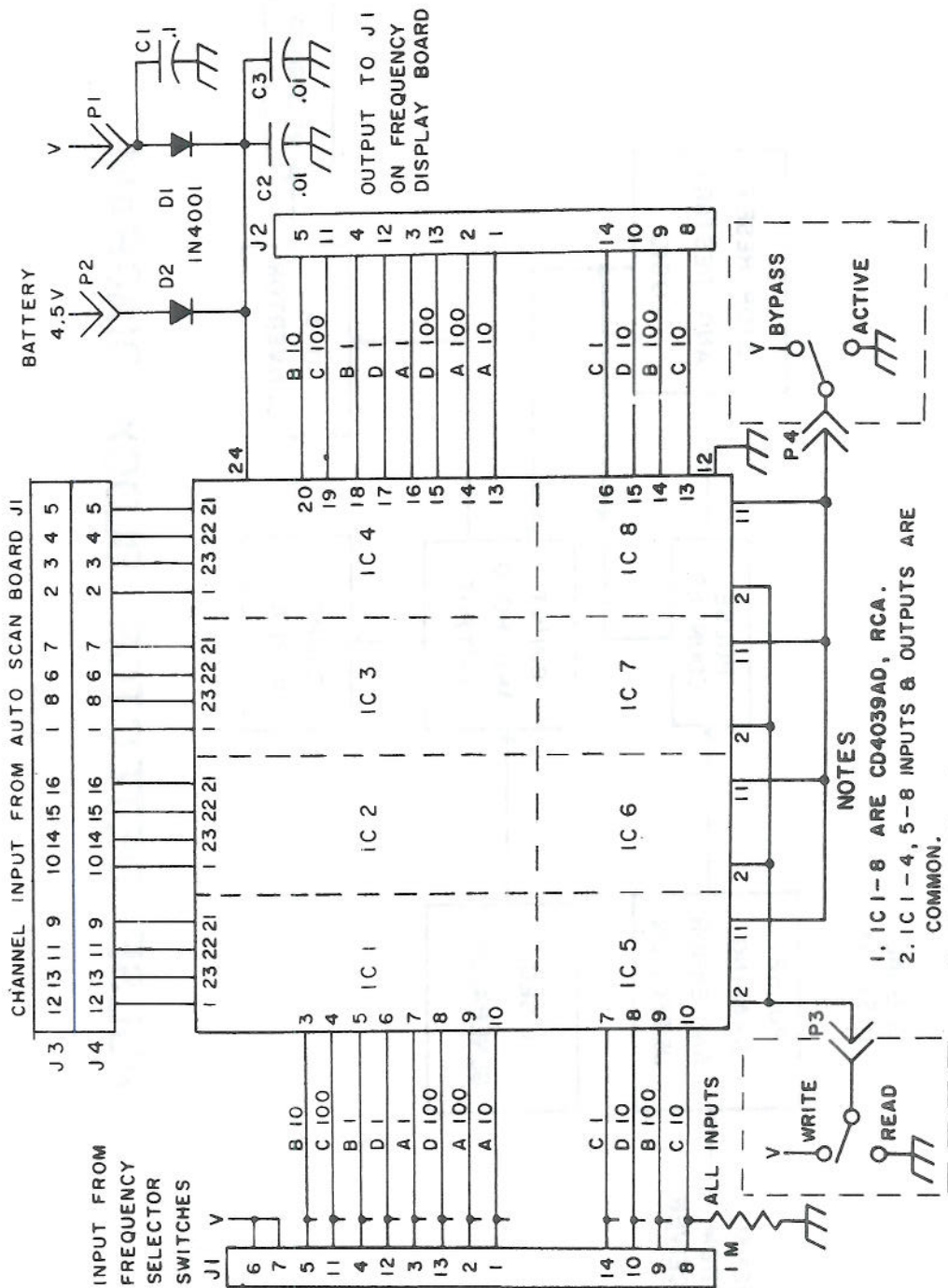

- NOTES**
1. IC 1-8 ARE CD4039AD, RCA.
  2. IC 1-4, 5-8 INPUTS & OUTPUTS ARE COMMON.
  3. IC 1 & 5, 2 & 6, 3 & 7, 4 & 8 CHANNEL INPUTS ARE COMMON.

### 16 CHANNEL MEMORY BOARD

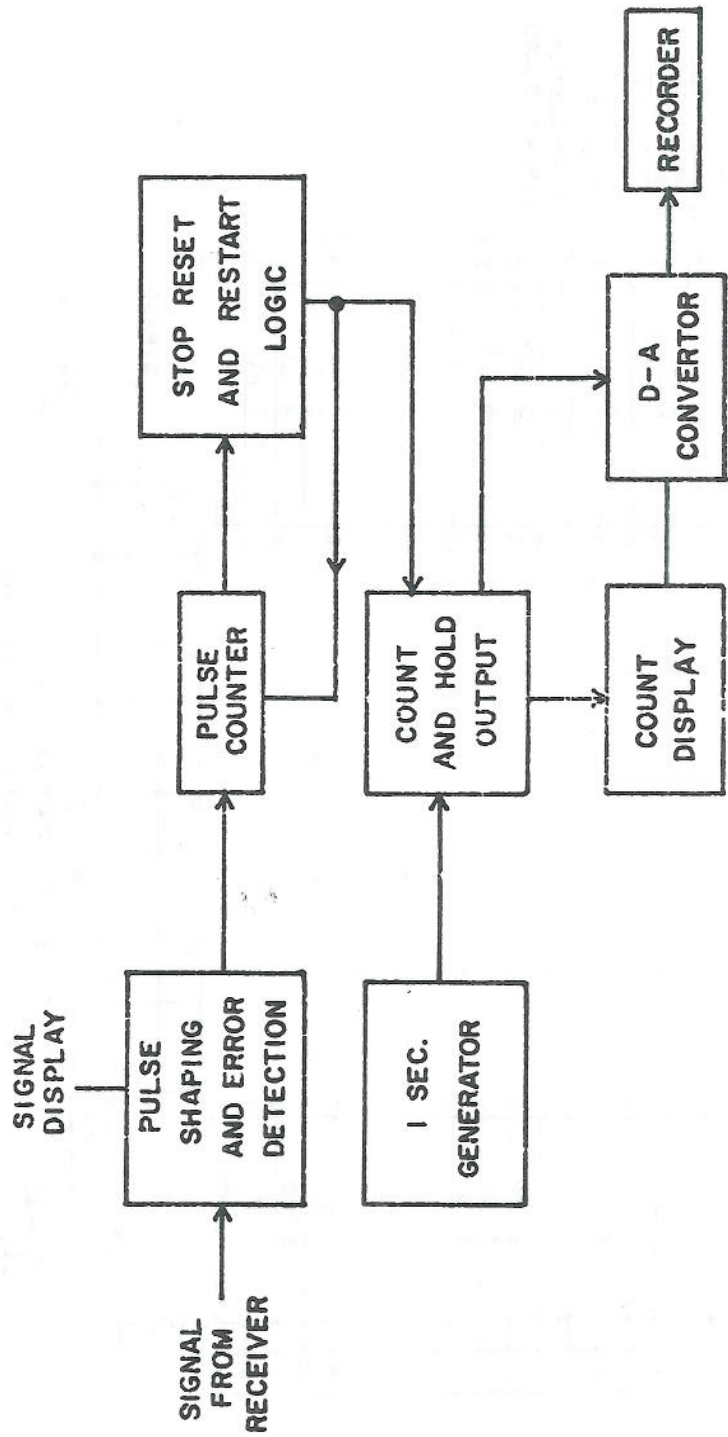

**PULSE DETECTOR BLOCK DIAGRAM**



Table D-1. WINTER AND EARLY SPRING 1975, FISH RADIO TAGGED AND DATA COLLECTED

<u>Species</u>	<u>Fish Id. No.</u>	<u>Sex</u>	<u>Wt. (g)</u>	<u>Date on (1975)</u>	<u>Date off (1975)</u>	<u>Track Perd. Days</u>	<u>No. of Loc.</u>	<u>No. of Temperature Readings</u>
Walleye	100		340	2/5	2/14	10	23	
N. Pike	101		907	2/4	3/18	43	24	
N. Pike	102	F	3969	2/13	5/12	89	104	
N. Pike	103	F	5670	2/16	2/18	31	44	
Lm. Bass	104	M	567	2/16	4/16	60	104	
N. Pike	105	F	3062	2/18	2/19	2	3	
N. Pike	106	F	4309	2/20	3/6	14	28	
Perch	107	F	340	2/25	3/24	28	61	
Perch	108	F	340	2/24	3/28	33	66	
Perch	109	F	340	2/24	4/2	38	57	
Perch	110	F	454	2/26	3/23	26	43	
Perch	111	F	340	2/26	4/5	39	61	
Perch	113	F	397	3/9	4/10	33	51	
Perch	114	F	482	3/16	3/16	1	1	
N. Pike	1006		1588	4/2	4/3	2	4	
Perch	1009	M	284	4/3	4/19	17	32	
Lm. Bass	1011	F	928	4/2	5/22	51	35	
N. Pike	1012	F	3232	4/2	4/27	26	23	
Perch	1013	F	482	4/4	5/12	39	43	
Perch	1014	F	397	4/4	5/4	31	52	
N. Pike	1015	F	1764	4/10	5/2	42	48	103
Perch	1016	F	425	4/11	5/6	26	31	
Perch	1017	F	454	4/10	5/20	41	55	
Perch	1018	F	454	4/10	4/24	15	27	
Perch	1032	F	340	4/12	5/10	29	42	
Perch	1033	M	284	4/12	5/10	19	37	
Walleye	1057	M	709	4/14	4/25	12	9	15
Walleye	1081		482	4/19	5/9	22	28	
Perch	1153	M	312	4/25	5/22	28	23	
Perch	1159	F	567	4/26	5/22	27	18	28
Perch	1183	M	340	4/25	5/22	28	37	
Perch	1214	F	340	5/3	5/21	19	8	
Walleye	1215	M	1247	4/30	5/4	5	4	6
Walleye	1794	F	2495	5/13	5/21	9	10	
Walleye	1800	F	2296	5/13	5/22	10	9	
Walleye	1801	F	2778	5/19	5/21	3	3	

Table D-2. AUTUMN 1975, FISH TAGGED AND DATA COLLECTED

<u>Species</u>	<u>Fish Id. No.</u>	<u>Sex</u>	<u>Wt. (g)</u>	<u>Date on (1975)</u>	<u>Date off (1975)</u>	<u>Track Perd. Days</u>	<u>No. of Loc.</u>	<u>No. of Temperature Readings</u>
Perch	1805	F	397	9/26	10/31	36	29	
Perch	1807	F	425	10/3	10/3	0	0	
Perch	1808		340	10/3	11/15	44	41	
Perch	1810	F	425	10/3	11/7	36	27	
Perch	1812	F	369	10/3	11/14	43	39	
Perch	1813	F	397	10/3	11/19	48	44	
Walleye	1814		1588	10/7	11/20	45	46	
Walleye	1815	F	3190	10/9	11/19	42	39	
Walleye	1816	F	3062	10/9	11/12	35	34	
Perch	1817	F	454	10/9	11/1	24	20	
Perch	1818		340	10/9	11/23	46	44	
Perch	1819	F	397	10/16	10/24	9	9	
Perch	1820	F	340	10/16	12/11	56	51	
Perch	1821	F	340	10/26	11/26	32	29	
Perch	1822	F	482	11/4	11/9	6	5	
Perch	1824	F	397	11/4	12/20	47	41	
Perch	1825	F	510	11/5	12/16	42	20	
Perch	1826	F	482	11/5	12/12	38	35	
Perch	1827	F	482	11/5	12/14	40	35	
Perch	1828		340	11/27	1/1/76	36	25	
Perch	1829	F	340	11/27	12/18	22	19	
Perch	1830	F	340	11/27	1/1/76	36	22	
Perch	1831	F	312	11/27	12/23	27	23	

Table D-3. WINTER AND EARLY SPRING 1976, FISH TAGGED AND DATA COLLECTED

<u>Species</u>	<u>Fish Id. No.</u>	<u>Sex</u>	<u>Wt. (g)</u>	<u>Date on (1976)</u>	<u>Date off (1976)</u>	<u>Track Perd. Days</u>	<u>No. of Loc.</u>	<u>No. of Temperature Readings</u>
Perch	1833	F	482	1/5	3/3	58	40	79
Perch	1834	F	383	1/11	1/30	20	41	130
Perch	1835	F	397	1/17	1/17	0	0	0
Perch	1836	F	454	1/29	5/27	119	39	48
Perch	1837	F	340	1/29	5/2	125	88	1137
Perch	1838	F	383	1/29	4/4	66	53	342
Perch	1839	F	340	1/29	2/25	28	7	24
Perch	1840	F	454	2/3	2/16	14	15	
Perch	1841	F	383	2/3	3/24	50	31	
Perch	1842	F	354	2/8	3/8	29	31	353
Perch	1843	F	369	2/8	3/9	30	22	91
Perch	1844	F	326	2/8	4/13	65	47	45
Perch	1845	F	454	2/21	2/21	1	1	1
Perch	1846	F	482	2/26	5/9	72	29	29
Perch	1847	F	367	2/27	4/20	53	41	62
Perch	1848	F	454	3/25	5/9	46	32	203
Perch	1850	F	567	4/11	4/18	8	12	
Perch	1851	F	482	4/11	6/2	53	37	
Perch	1852	F	482	4/11	5/9	29	38	
Perch	1853	F	425	4/11	6/2	53	30	
Perch	1854	F	425	4/11	5/9	29	26	
Perch	1855	F	397	4/21	6/2	43	18	
Perch	1856	F	425	4/21	5/16	26	17	
Perch	1857	F	412	4/23	4/27	5	5	



Table D-4. AUTUMN 1976, FISH TAGGED AND DATA COLLECTED

<u>Species</u>	<u>Fish Id. No.</u>	<u>Sex</u>	<u>Wt. (g)</u>	<u>Date on (1976)</u>	<u>Date off (1976)</u>	<u>Track. Perd. Days</u>	<u>No. of Locations</u>
Perch	3001	F	369	9/11	9/25	15	12
Perch	3002	F	312	9/10	10/6	27	25
Perch	3003	F	340	9/10	9/17	8	5
Perch	3004	F	340	9/10	10/19	40	34
Perch	3006	F	425	9/10	9/24	15	12
Perch	3007	F	340	9/24	10/21	28	28
Perch	3008	F	312	9/10	9/28	19	16
Perch	3009	F	369	9/11	10/17	37	34
Perch	3010	F	326	9/24	10/27	34	32
Perch	3011	F	340	9/11	10/20	37	40
Perch	3012	F	340	9/11	9/28	18	14
Perch	3013	F	369	9/10	9/17	6	5
Perch	3014	F	369	9/11	11/3	54	48
Perch	3015	F	354	9/12	9/21	10	7
Perch	3016	F	354	9/24	10/31	38	37
Perch	3017	F	312	9/12	9/17	6	5
Perch	3018	F	340	9/16	9/16	0	0
Perch	3020	F	354	9/16	9/24	9	6
Perch	3021	F	326	9/17	10/2	17	14
Perch	3022	F	312	9/17	10/8	22	20
Perch	3023	F	340	10/16	11/12	28	25
Perch	3024	F	369	10/12	11/19	39	30
Perch	3026	F	312	10/12	11/19	39	30
Perch	3027	F	312	10/12	11/24	44	31
Perch	3028	F	298	10/12	10/30	19	19
Perch	3029	F	369	10/16	11/30	46	25
Perch	3030	F	397	10/19	10/19	0	0
Perch	3031	F	284	10/16	11/30	46	25

Table D-4. (CONTINUED) AUTUMN 1976, FISH TAGGED AND DATA COLLECTED

<u>Species</u>	<u>Fish Id. No.</u>	<u>Sex</u>	<u>Wt. (g)</u>	<u>Date on (1976)</u>	<u>Date off (1976)</u>	<u>Track. Perd. Days</u>	<u>No. of Locations</u>
Perch	3032	F	298	10/20	11/30	42	35
Perch	3033	F	369	10/16	11/19	35	23
Perch	3034	F	340	10/16	11/30	46	28
Perch	3035	F	369	10/16	11/3	19	17
Perch	3036	F	397	10/20	11/7	19	17
Perch	3039	F	354	10/20	11/30	42	25
Perch	3040	F	284	10/20	11/30	42	35
Perch	3041	F	298	10/20	11/30	42	24
Perch	3042	F	340	10/20	10/20	1	1
Perch	3043	F	284	10/20	11/9	23	19
Walleye	2048		1701	10/16	11/15	31	17
Walleye	3049	F	1361	10/16	11/2	19	17
Perch	3050	F	284	10/23	11/30	39	21
Perch	3052	F	284	11/6	11/30	25	20
Perch	3054	F	284	10/23	11/24	32	31
Perch	3055	F	312	11/6	11/30	25	20
Perch	3056	F	326	11/6	11/30	25	19
Perch	3057	F	354	11/6	11/30	25	14
Perch	3059	F	354	11/6	11/30	25	20
Perch	3060A	F	312	11/6	11/19	14	10
Perch	3060B	F	397	11/6	11/30	25	19
Perch	3063	F	383	11/6	11/30	25	20
Perch	3065	F	383	11/6	11/30	25	17
Perch	3067	F	539	11/6	11/24	18	19
Perch	3068	F	439	11/6	11/30	25	19
Perch	3071	F	397	11/6	11/30	25	20

## APPENDIX E

### ACCURACY OF LOCATING RADIO TAGGED FISH BY TRIANGULATION

Accuracy and precision of animal tracking depend upon 3 major factors as discussed by Heezen and Tester (1967) and Slade, et al. (1965): System errors or the difference between tower determined bearing and the true bearing to the animal could be caused by wind twisting the antennas, inaccurate calibration and radio frequency interference. Reading errors depended upon the ability of a person to detect signal nulls, resolution of compass cards under differing light conditions and fatigue. Signal nulls were the point at which a transmitter was no longer audible when rotating a directional antenna. In general 2 nulls were located symmetrically on either side of the peak signal. Nulls could be discriminated with more precision than maximum signal strength. Thus, determining maximum signal (the bearing to an animal) from 2 symmetric nulls was more reliable than attempting to discriminate actual signal peaks. Finally, accuracy depended upon the animal's location and movement with respect to the receiving antenna. Triangulation errors increased in any direction from the  $90^\circ$  intersection of bearings at the perpendicular bisector of the base line (an imaginary line connecting the antennas). Also, readings to more distant animals inherently had a greater error, as bearing error had greater significance as distance increases.

Tests conducted on our shore tower array indicate bearing errors caused less than 5 m location error at 100 m and 43 m at 800 m (Winter et al. 1978). These results compare closely with Yagi accuracy tests conducted by Marshall (1962 and 1963), and Slade, et al. (1965). To determine precision of the system over time we routinely took location bearings to a stationary reference transmitter in the discharge bay from all 3 towers while tracking fish. When taking bearings from 3 locations to a point, an error triangle was generated unless all 3 bearings coincided at exactly the same point. The average size of the triangle over time should have resulted in an area that came close to estimating the precision of the system. We found this area to be  $232.4 \text{ m}^2$  or approximately comparable to a circle with a 8.6 m radius. Actual reference transmitter locations were plotted on an X, Y coordinate system as the center of the error triangle. By summing the X and Y locations of a stationary transmitter a standard error of the mean was found to be 6.9 m on the Y axis and 2.8 m on the X axis. The center of this reference area was an average of 307 m from the 3 towers.



Mobile tracking techniques offered the advantage of approaching an animal closely and positioning bearings to cross closer to the optimum 90° intersection. However, reference positions of the antennas were usually somewhat more difficult to determine especially under adverse light and weather conditions. Winter et al. (1978) determined a 14 m bearing error from a distance of 200 m with a truck mounted Yagi. Loop antennas can be very accurate, especially at close ranges. Verts (1963) reported that triangulations from his truck mounted loop antenna were  $\pm 7.6$  m at 400 m and  $\pm 23$  m from 800 m. Winter et al. (1978) reported 2 tests conducted with loop antennas. The results indicated a calculated mean location error ranging from 0.79 m (5-15 m distance class) to 6.49 m (76-92 m class). Our tests with mobile tracking equipment to a transmitter at a fixed location indicted a standard error of the mean to be 5.2 m on the X axis and 8.0 m on the Y axis. In summary, our tests and those in the literature indicated that in general, location errors were less than 10% of the distance from the receiving antenna to the transmitter.

### References

- Heezen, K.L. and J.R. Tester. 1967. Evaluation of radio-tracking triangulation with special reference to deer movements. *J. Wildl. Manage.* 31(1):124-141.
- Marshall, W.H. 1962. Development and use of short wave radio transmitters to trace animal movements. Progress Report, Univ. of Minn. 18 pp. (multilithed).
- Marshall, W.H. 1963. Studies of movements, behavior and activities of ruffed grouse using radio telemetry techniques. Progress Report, Univ. of Minn. 30 pp. (multilithed).
- Slade, N.A., J.J. Cebula and R.J. Robel. 1965. Accuracy and reliability of biotelemetric instruments used in animal movement studies in prairie grasslands of Kansas. *Trans. Kansas Acad. Sci.* 68(1):173-179.
- Verts, S.J. 1963. Equipment and techniques for radio-tracking striped skunks. *J. Wildl. Manage.* 27(3):325-339.
- Winter, J.D., V.B. Kuechle, D.B. Siniff and J.R. Tester. 1978. Equipment and methods for radio tracking freshwater fish. Univ. of Minn. Inst. of Ag. Misc. Bul. 152. 45 p.

**TECHNICAL REPORT DATA**  
(Please read Instructions on the reverse before completing)

1. REPORT NO. EPA-600/3-80-009		2.	3. RECIPIENT'S ACCESSION NO.	
4. TITLE AND SUBTITLE Spatial Distribution and Temperature Selection of Fish Near the Thermal Outfall of a Power Plant During Fall, Winter and Spring		5. REPORT DATE January 1980 issuing date		6. PERFORMING ORGANIZATION CODE
7. AUTHOR(S) M. J. Ross and D. B. Siniff		8. PERFORMING ORGANIZATION REPORT NO.		
9. PERFORMING ORGANIZATION NAME AND ADDRESS University of Minnesota Minneapolis, Minnesota 55455		10. PROGRAM ELEMENT NO.		11. CONTRACT/GRANT NO. 68-03-2145 R804997010
12. SPONSORING AGENCY NAME AND ADDRESS Environmental Research Laboratory - Duluth, MN Office of Research and Development U.S. Environmental Protection Agency Duluth, Minnesota 55804		13. TYPE OF REPORT AND PERIOD COVERED		14. SPONSORING AGENCY CODE EPA/600/03
15. SUPPLEMENTARY NOTES				
16. ABSTRACT  <p>The movement patterns of 4 fish species; yellow perch (<i>Perca flavescens</i>), northern pike (<i>Esox lucius</i>), largemouth bass (<i>Micropterus salmoides</i>) and walleye (<i>Stizostedion vitreum</i>) were monitored by radio telemetry near the thermal discharge of a power plant (<math>\Delta T</math> 15°C nominal). Fish movements relative to depth, temperature, center of the home range, discharge point, and release location are examined. Near thermally altered areas northern pike exhibited the greatest amount of movement followed by yellow perch, walleye and largemouth bass. Except for largemouth bass, thermal experience was found to be transitory. An overall mean winter temperature selection of 5.4°C was determined for yellow perch. While only in the thermally altered area yellow perch had a slightly higher mean thermal experience, 6.3°C. Yellow perch were not found to be attracted from the surrounding areas into the heated waters of the discharge bay during the cooler months. Not until spring was a population concentrating influence observed and that was believed due to indirect influences; more cover due to greater available light in the ice free area contributing to a higher standing stock of aquatic vegetation.</p> <p>We concluded that temperature, when in concert with numerous other environmental variables, did not alter the distribution of yellow perch to that predicted on the basis of laboratory temperature preference studies. Furthermore, movement patterns of northern pike, walleye and largemouth bass were found to be relatively similar to those reported from thermally unaltered areas.</p>				
17. KEY WORDS AND DOCUMENT ANALYSIS				
a. DESCRIPTORS		b. IDENTIFIERS/OPEN ENDED TERMS	c. COSATI Field/Group	
Yellow perch Northern pike Walleye Largemouth bass Behavior Temperature Radio telemetry		Habitat-selection Behavioral-thermoregulation Winter-movements Attraction	06/F	
18. DISTRIBUTION STATEMENT RELEASE TO PUBLIC		19. SECURITY CLASS (This Report) UNCLASSIFIED	21. NO. OF PAGES 129	
		20. SECURITY CLASS (This page) UNCLASSIFIED	22. PRICE	













United States  
Environmental Protection  
Agency

Environmental Research Information  
Center  
Cincinnati OH 45268

Official Business  
Penalty for Private Use, \$300

Postage and  
Fees Paid  
Environmental  
Protection  
Agency  
EPA-335



Special Fourth-Class Rate  
Book

Please make all necessary changes on the above label,  
detach or copy, and return to the address in the upper  
left-hand corner.

If you do not wish to receive these reports CHECK HERE :  
detach, or copy, this cover, and return to the address in the  
upper left-hand corner.

EPA-600/3-80-009