

# **Fish Protection at Cooling Water Intake Structures**

*A Technical Reference Manual – 2012 Update*

**3002000231**

---



# **Fish Protection at Cooling Water Intake Structures**

*A Technical Reference Manual – 2012 Update*

3002000231

Technical Update, February 2013

EPRI Project Manager

D. Dixon

## **DISCLAIMER OF WARRANTIES AND LIMITATION OF LIABILITIES**

THIS DOCUMENT WAS PREPARED BY THE ORGANIZATION(S) NAMED BELOW AS AN ACCOUNT OF WORK SPONSORED OR COSPONSORED BY THE ELECTRIC POWER RESEARCH INSTITUTE, INC. (EPRI). NEITHER EPRI, ANY MEMBER OF EPRI, ANY COSPONSOR, THE ORGANIZATION(S) BELOW, NOR ANY PERSON ACTING ON BEHALF OF ANY OF THEM:

(A) MAKES ANY WARRANTY OR REPRESENTATION WHATSOEVER, EXPRESS OR IMPLIED, (I) WITH RESPECT TO THE USE OF ANY INFORMATION, APPARATUS, METHOD, PROCESS, OR SIMILAR ITEM DISCLOSED IN THIS DOCUMENT, INCLUDING MERCHANTABILITY AND FITNESS FOR A PARTICULAR PURPOSE, OR (II) THAT SUCH USE DOES NOT INFRINGE ON OR INTERFERE WITH PRIVATELY OWNED RIGHTS, INCLUDING ANY PARTY'S INTELLECTUAL PROPERTY, OR (III) THAT THIS DOCUMENT IS SUITABLE TO ANY PARTICULAR USER'S CIRCUMSTANCE; OR

(B) ASSUMES RESPONSIBILITY FOR ANY DAMAGES OR OTHER LIABILITY WHATSOEVER (INCLUDING ANY CONSEQUENTIAL DAMAGES, EVEN IF EPRI OR ANY EPRI REPRESENTATIVE HAS BEEN ADVISED OF THE POSSIBILITY OF SUCH DAMAGES) RESULTING FROM YOUR SELECTION OR USE OF THIS DOCUMENT OR ANY INFORMATION, APPARATUS, METHOD, PROCESS, OR SIMILAR ITEM DISCLOSED IN THIS DOCUMENT.

REFERENCE HEREIN TO ANY SPECIFIC COMMERCIAL PRODUCT, PROCESS, OR SERVICE BY ITS TRADE NAME, TRADEMARK, MANUFACTURER, OR OTHERWISE, DOES NOT NECESSARILY CONSTITUTE OR IMPLY ITS ENDORSEMENT, RECOMMENDATION, OR FAVORING BY EPRI.

THE FOLLOWING ORGANIZATION, UNDER CONTRACT TO EPRI, PREPARED THIS REPORT:

**Alden Research Laboratory, Inc.**

**This is an EPRI Technical Update report. A Technical Update report is intended as an informal report of continuing research, a meeting, or a topical study. It is not a final EPRI technical report.**

### **NOTE**

For further information about EPRI, call the EPRI Customer Assistance Center at 800.313.3774 or e-mail [askepri@epri.com](mailto:askepri@epri.com).

Electric Power Research Institute, EPRI, and TOGETHER...SHAPING THE FUTURE OF ELECTRICITY are registered service marks of the Electric Power Research Institute, Inc.

Copyright © 2013 Electric Power Research Institute, Inc. All rights reserved.



# ACKNOWLEDGMENTS

The following organization, under contract to the Electric Power Research Institute (EPRI), prepared this report:

Alden Research Laboratory, Inc.  
30 Shrewsbury Street  
Holden, MA 01520

Principal Investigators

J. Black  
T. Hogan  
K. Lamontagne  
D. Giza

This report describes research sponsored by EPRI.

---

This publication is a corporate document that should be cited in the literature in the following manner:

*Fish Protection at Cooling Water Intake Structures: A Technical Reference Manual – 2012 Update.* EPRI, Palo Alto, CA: 2013. 3002000231.



# PRODUCT DESCRIPTION

---

This report provides an updated review of the state of knowledge on fish protection technologies for use at power plant cooling water intake structures (CWISs) to meet requirements of §316(b) of the Clean Water Act (CWA). While it is not possible to know with certainty how the §316(b) Final Rule will look (it is scheduled to be issued on or before June 27, 2013), it is anticipated that power generating facilities will have some flexibility in selecting fish protection technologies. The information provided in this report can be used by power generators, resource managers, and permitting agencies to determine the potential for different fish protection technologies to reduce impingement and/or entrainment losses at CWISs. This report will be updated in 2013 in accordance with the final EPA Existing Facility §316(b) Rule requirements.

## **Background**

Section 316(b) of the CWA requires that the location, design, construction, and capacity of CWISs reflect the best technology available for minimizing adverse environmental impact. EPA issued a final Rule for new (those constructed after January 1, 2001) facilities in 2001. On April 20, 2011, EPA proposed a revised §316(b) Rule for existing power plants and other industrial facilities using cooling water. In June 2012, EPA, via a Notice of Data Availability, modified the proposed impingement compliance options and added additional options for review and public comment. Under the proposed Rule, facilities would use fish protection technologies to reduce impingement and entrainment losses. Information on fish protection technologies and their biological performance, in particular, is the subject of this report. A final §316(b) Rule for existing power plants and other industrial facilities that use cooling water will be issued by EPA on or before June 27, 2013.

## **Objective**

The objective of this report is to provide a comprehensive and up-to-date review of the state of knowledge on the performance, operational and maintenance requirements, and costs of CWIS fish and shellfish protection technologies that can be used to meet the EPA §316(b) Rules for new and existing power plants and other industrial facilities.

## **Approach**

A literature search was conducted to identify available literature describing the application and evaluation of fish protection technologies. All relevant reports and publications were reviewed, and project design, study methods, and effectiveness results were summarized. A brief description of each technology is provided, and permanent installations are discussed. Also, the current and future status of each technology is assessed.

## **Results**

Fish protection technologies are generally grouped into five functional categories—physical barriers, collection systems, diversion systems, behavioral guidance devices, and flow reduction. The performance, operational and maintenance issues, and documented installations of each

technology in each functional category are described in the report. The results of the review indicate the importance of site-specific factors to the biological effectiveness and engineering practicality of a technology. These factors include species and life stages present, facility design and operating characteristics, and environmental factors (for example, debris loading) resulting from physical, chemical, and hydrologic features.

No single intake technology proved effective and practical for all situations, even within geographic regions. Information assembled and provided in this report, however, will be useful in assessing which types of technologies would most likely provide protection to fish and shellfish. The review also found that considerable opportunity exists to optimize the performance of current technologies and to develop entirely new technologies.

### **Applications, Value, and Use**

Information contained in this report will assist project owners, permit applicants, and others to narrow the potentially applicable fish protection technologies to those that hold the greatest potential to meet the national performance standards under the site-specific conditions of a given facility. The information will also assist permit applicants to cost-effectively assemble and file §316(b) NPDES permit application material—most important, the EPA proposed Rule and expected Final Rule—required Comprehensive Technical Feasibility and Cost Evaluation Study.

### **Keywords**

Clean Water Act Section 316(b)

Cooling water intake structures

Fish and shellfish protection

Fish protection technologies

# CONTENTS

|                                            |            |
|--------------------------------------------|------------|
| <b>1 INTRODUCTION .....</b>                | <b>1-1</b> |
| Section 316(b) of the Clean Water Act..... | 1-1        |
| Purpose of Technology Review .....         | 1-3        |
| Approach and Report Organization.....      | 1-3        |
| Future Direction.....                      | 1-6        |
| <b>2 TRAVELING WATER SCREENS.....</b>      | <b>2-1</b> |
| Introduction .....                         | 2-1        |
| Unmodified Traveling Screens .....         | 2-2        |
| Modified Traveling Screens.....            | 2-3        |
| Case Studies – CWIS Application.....       | 2-14       |
| Dunkirk Steam Station .....                | 2-14       |
| Huntley Steam Station .....                | 2-21       |
| Salem Generating Station .....             | 2-27       |
| Calvert Cliffs Nuclear Power Plant.....    | 2-30       |
| Somerset Station.....                      | 2-31       |
| Arthur Kill Station .....                  | 2-33       |
| Oswego Steam Station .....                 | 2-38       |
| Belle River Power Plant .....              | 2-40       |
| Roseton Generating Station.....            | 2-42       |
| Brayton Point Station .....                | 2-48       |
| Prairie Island Generating Plant .....      | 2-50       |
| Big Bend Station .....                     | 2-52       |
| Indian Point Generating Station .....      | 2-58       |
| Brunswick Steam Electric Plant .....       | 2-65       |
| Danskammer Point Generating Station.....   | 2-70       |
| Mystic Station.....                        | 2-74       |
| Barney M. Davis Power Station .....        | 2-75       |
| Bowline Point Generating Station .....     | 2-78       |
| Oyster Creek Generating Station .....      | 2-83       |
| Hanford Reservation .....                  | 2-85       |
| Surry Power Station .....                  | 2-87       |
| Manchester Street Station.....             | 2-88       |
| Millstone Nuclear Power Plant, Unit 3..... | 2-90       |
| Scattergood Generating Station.....        | 2-91       |
| H. A. Wagner Generating Station.....       | 2-93       |
| E. F. Barrett Generating Station .....     | 2-94       |
| Hudson Generating Station Station.....     | 2-96       |
| Potomac Generating Station .....           | 2-99       |
| Fort Calhoun Station .....                 | 2-104      |

|                                                                              |            |
|------------------------------------------------------------------------------|------------|
| North Omaha Station .....                                                    | 2-106      |
| Case Studies – Laboratory Studies.....                                       | 2-107      |
| Laboratory Study, Redondo Beach, CA .....                                    | 2-107      |
| Laboratory Study, ESEERCO/Alden Research Laboratory.....                     | 2-116      |
| Laboratory Study, Tennessee Valley Authority .....                           | 2-117      |
| Laboratory Study – EPRI/Alden .....                                          | 2-118      |
| Laboratory Study – Hydrolo/Alden .....                                       | 2-124      |
| Laboratory Study – EPRI/Alden .....                                          | 2-128      |
| Laboratory Study – EPRI/Alden .....                                          | 2-134      |
| Laboratory Study – EPRI/Alden .....                                          | 2-140      |
| Laboratory Study – Aquaria/Alden .....                                       | 2-141      |
| Laboratory Study – EPRI/Alden .....                                          | 2-147      |
| <b>3 STATIONARY SCREENS .....</b>                                            | <b>3-1</b> |
| Introduction .....                                                           | 3-1        |
| Case Studies – CWIS Application.....                                         | 3-1        |
| Brunswick Steam Electric Plant .....                                         | 3-1        |
| Case Studies – Field Studies .....                                           | 3-3        |
| Oxbow Fish Hatchery Cascade Locks, Oregon .....                              | 3-3        |
| <b>4 DRUM SCREENS.....</b>                                                   | <b>4-1</b> |
| Introduction .....                                                           | 4-1        |
| Rotary Drum Screens.....                                                     | 4-1        |
| Angled Rotary Drum Screens .....                                             | 4-1        |
| Case Studies – Rotary Drum Screens - Water Diversion Field Tests.....        | 4-3        |
| Eagle Point Irrigation District.....                                         | 4-3        |
| Irrigation Canal No. 1, City of Yakima, WA .....                             | 4-3        |
| Patterson Irrigation District.....                                           | 4-3        |
| Pacific Power and Light.....                                                 | 4-3        |
| Various Sites – Idaho .....                                                  | 4-4        |
| Woodbridge Fish Facility.....                                                | 4-4        |
| Glenn-Colusa Irrigation District .....                                       | 4-4        |
| Savage Rapids Diversion System.....                                          | 4-4        |
| Case Studies – Rotary Drum Screens – Hydroelectric Field Tests.....          | 4-5        |
| White River Hydroelectric Plant .....                                        | 4-5        |
| Sizewell Power Station.....                                                  | 4-5        |
| Case Studies – Angled Rotary Drum Screens – Water Diversion Field Tests..... | 4-6        |
| Yakima River Basin.....                                                      | 4-6        |
| <b>5 CYLINDRICAL WEDGEWIRE SCREENS .....</b>                                 | <b>5-1</b> |
| Introduction .....                                                           | 5-1        |
| Case Studies – CWIS Application.....                                         | 5-3        |
| Logan Generating Plant .....                                                 | 5-3        |

|                                                                                             |            |
|---------------------------------------------------------------------------------------------|------------|
| Cope Station .....                                                                          | 5-4        |
| Eddystone Generating Station .....                                                          | 5-4        |
| Jeffrey Energy Center .....                                                                 | 5-5        |
| Chalk Point Station.....                                                                    | 5-7        |
| Charles Point Recovery Facility .....                                                       | 5-10       |
| Oyster Creek Nuclear Generating Station.....                                                | 5-10       |
| St. John’s River, FL.....                                                                   | 5-14       |
| J. H. Campbell, Unit 3 .....                                                                | 5-15       |
| Case Studies – Hydroelectric Application .....                                              | 5-16       |
| Arbuckle Mountain Hydroelectric Project .....                                               | 5-16       |
| Case Studies – Laboratory and Field Evaluations .....                                       | 5-16       |
| Laboratory Test EPRI/EPA, Alden Research Laboratory.....                                    | 5-16       |
| Laboratory Evaluation – Delmarva Power and Light.....                                       | 5-21       |
| Laboratory Evaluation – Entergy/Alden.....                                                  | 5-25       |
| Field Evaluation - Narragansett Bay, RI; Portage River, OH; and<br>Chesapeake Bay, VA ..... | 5-26       |
| Field Evaluation - Haverstraw Bay, Hudson River, New York.....                              | 5-44       |
| Field Evaluation – Mississippi River, Mississippi.....                                      | 5-51       |
| Field Evaluation – Marin Municipal Water District Desalination (MMWD) Pilot Plant...        | 5-52       |
| <b>6 BARRIER NETS .....</b>                                                                 | <b>6-1</b> |
| Introduction .....                                                                          | 6-1        |
| Case Studies – CWIS Application.....                                                        | 6-6        |
| Dallman Generating Station, Lake Springfield, Illinois .....                                | 6-6        |
| Bowline Point Generating Station, Hudson River, New York .....                              | 6-7        |
| Chalk Point Station.....                                                                    | 6-9        |
| J.P. Pulliam Plant, Fox River, Wisconsin .....                                              | 6-12       |
| Laskin, Colby Lake/Partridge River, Minnesota .....                                         | 6-14       |
| Baker River, Baker River, Washington.....                                                   | 6-14       |
| Arkansas Nuclear One, Dardanelle Reservoir, Arkansas .....                                  | 6-15       |
| LaSalle County Generating Station, Cooling Pond, Illinois .....                             | 6-16       |
| Crystal Falls, Paint River, Michigan.....                                                   | 6-16       |
| Highline Irrigation Canal, Highline Lake, Colorado.....                                     | 6-16       |
| Case Studies – Hydroelectric Application .....                                              | 6-17       |
| Ludington Pumped Storage Plant, Lake Michigan, Michigan.....                                | 6-17       |
| Pine Hydroelectric Project, Pine River, Wisconsin .....                                     | 6-19       |
| Brule Hydroelectric Project, Brule River, Wisconsin.....                                    | 6-21       |
| Hayward Hydroelectric Project, Namekagon River, Wisconsin.....                              | 6-22       |
| Banks Lake, Columbia River, Washington.....                                                 | 6-22       |
| Puntledge Hydroelectric Project, British Columbia.....                                      | 6-23       |
| Pickering Nuclear Generating Station, Lake Ontario, Ontario, Canada .....                   | 6-24       |
| Osage Hydropower Plant/Bagnell Dam, Osage River, Missouri .....                             | 6-25       |

|                                                                         |             |
|-------------------------------------------------------------------------|-------------|
| J. R. Whiting Plant.....                                                | 6-26        |
| <b>7 AQUATIC FILTER BARRIER.....</b>                                    | <b>7-1</b>  |
| Introduction .....                                                      | 7-1         |
| Case Studies – CWIS Application.....                                    | 7-2         |
| Lovett Generating Station .....                                         | 7-2         |
| Bethlehem Energy Center.....                                            | 7-7         |
| Case Studies – Field Evaluations .....                                  | 7-7         |
| Pisces.....                                                             | 7-7         |
| Case Studies – Laboratory Evaluations .....                             | 7-8         |
| NYSDEC .....                                                            | 7-8         |
| Electric Power Research Institute .....                                 | 7-9         |
| <b>8 POROUS DIKES .....</b>                                             | <b>8-1</b>  |
| Introduction .....                                                      | 8-1         |
| Case Studies.....                                                       | 8-1         |
| Wisconsin Electric Power Plants – Field Test and CWIS Application ..... | 8-1         |
| Brayton Point – Laboratory and Field Trials.....                        | 8-2         |
| Laboratory Evaluation – Kinetics .....                                  | 8-3         |
| Laboratory Evaluation – Consumers Power.....                            | 8-4         |
| <b>9 FISH PUMPS .....</b>                                               | <b>9-1</b>  |
| Introduction .....                                                      | 9-1         |
| Case Studies – CWIS Application.....                                    | 9-1         |
| Darlington Nuclear Generating Station .....                             | 9-1         |
| Sioux Power Plant.....                                                  | 9-2         |
| Monroe Power Plant.....                                                 | 9-7         |
| Case Studies – Water Diversion Applications.....                        | 9-9         |
| Red Bluff Research Pumping Plant.....                                   | 9-9         |
| Tracy Fish Collection Facility .....                                    | 9-17        |
| Agricultural Pump Station, Cherry Creek, Washington .....               | 9-23        |
| Case Studies – Hydroelectric Application .....                          | 9-24        |
| R. H. Saunders Generating Station.....                                  | 9-24        |
| Case Studies – Laboratory Evaluations .....                             | 9-25        |
| Laboratory Study – Ontario Hydro .....                                  | 9-25        |
| Laboratory Study – ESEERCO .....                                        | 9-27        |
| Laboratory Study – Nine-mile and Mystic Stations .....                  | 9-31        |
| <b>10 ANGLED SCREENS .....</b>                                          | <b>10-1</b> |
| Introduction .....                                                      | 10-1        |
| Case Studies – CWIS Application.....                                    | 10-2        |
| Oswego Steam Station .....                                              | 10-2        |
| Brayton Point.....                                                      | 10-5        |
| Danskammer Point.....                                                   | 10-7        |



|                                                                                     |             |
|-------------------------------------------------------------------------------------|-------------|
| Case Studies – Hydroelectric Application .....                                      | 10-9        |
| White River Hydroelectric Project .....                                             | 10-9        |
| Weeks Falls Hydroelectric Project .....                                             | 10-12       |
| Case Studies – Laboratory and Field Studies.....                                    | 10-13       |
| Field Study Newhalen River, Alaska .....                                            | 10-13       |
| Laboratory Evaluation – U.S. Fish and Wildlife Creston National Fish Hatchery ..... | 10-14       |
| Laboratory Study, Redondo Beach, CA .....                                           | 10-17       |
| Laboratory Study – ESEERCO .....                                                    | 10-21       |
| Laboratory Study – Tennessee Valley Authority .....                                 | 10-24       |
| Laboratory Study – Alden Research Laboratory .....                                  | 10-26       |
| Laboratory Study - California .....                                                 | 10-29       |
| Laboratory Study – University of California, Davis .....                            | 10-29       |
| <b>11 HIGH-VELOCITY SCREENS .....</b>                                               | <b>11-1</b> |
| Introduction .....                                                                  | 11-1        |
| Modular Inclined Screens (MIS).....                                                 | 11-1        |
| Eicher Screens.....                                                                 | 11-2        |
| Case Studies – Hydroelectric Field Application .....                                | 11-3        |
| Green Island.....                                                                   | 11-3        |
| Puntledge Hydroelectric Project.....                                                | 11-4        |
| T. W Sullivan Plant.....                                                            | 11-5        |
| Elwha Hydroelectric Project .....                                                   | 11-6        |
| Case Studies – Laboratory Studies.....                                              | 11-8        |
| Laboratory Study – Denver, CO .....                                                 | 11-8        |
| EPRI/Alden Laboratory Study .....                                                   | 11-13       |
| Hydraulic Model Study – Alden .....                                                 | 11-14       |
| EPRI/University of Washington Laboratory Study.....                                 | 11-14       |
| <b>12 ANGLED BAR RACKS AND LOUVERS .....</b>                                        | <b>12-1</b> |
| Introduction .....                                                                  | 12-1        |
| Case Studies – Hydroelectric and Water Diversion Applications.....                  | 12-2        |
| Grand Falls – Windsor Hydroelectric Project .....                                   | 12-2        |
| T. W. Sullivan Hydroelectric Project.....                                           | 12-6        |
| Vernon Hydroelectric Station .....                                                  | 12-6        |
| Tracy Fish Collection Facility .....                                                | 12-7        |
| Holyoke Canal – Hadley Falls Hydroelectric Project.....                             | 12-9        |
| Red Bluff Diversion Dam.....                                                        | 12-10       |
| Case Studies – Laboratory Evaluations .....                                         | 12-13       |
| EPRI.....                                                                           | 12-13       |
| Laboratory Evaluation – EPRI.....                                                   | 12-18       |
| Laboratory Evaluation – EPRI.....                                                   | 12-20       |
| Laboratory Evaluation - Conte Anadromous Fish Research Center .....                 | 12-22       |

|                                                                                   |             |
|-----------------------------------------------------------------------------------|-------------|
| Laboratory Evaluation - Conte Anadromous Fish Research Center .....               | 12-23       |
| Laboratory Study – Alden Research Laboratory .....                                | 12-23       |
| Laboratory Study – Redondo Beach Generating Station .....                         | 12-24       |
| <b>13 LIGHTS .....</b>                                                            | <b>13-1</b> |
| Introduction .....                                                                | 13-1        |
| Strobe Lights .....                                                               | 13-1        |
| Mercury Lights.....                                                               | 13-10       |
| Other Light Sources .....                                                         | 13-14       |
| Case Studies – Strobe Light – CWIS Field Tests .....                              | 13-18       |
| Milliken Steam Electric Station .....                                             | 13-18       |
| Roseton Generating Station .....                                                  | 13-19       |
| Pickering Generating Station .....                                                | 13-21       |
| Case Studies – Strobe Light – Hydroelectric/Water Diversion Field Tests .....     | 13-22       |
| Hiram M. Chittenden Locks .....                                                   | 13-22       |
| White Rapids Hydroelectric Project.....                                           | 13-23       |
| Burbank 3 Intake Channel.....                                                     | 13-23       |
| McNary Dam .....                                                                  | 13-24       |
| Mattaceunk Hydroelectric Project .....                                            | 13-24       |
| Four Mile Hydroelectric Project .....                                             | 13-25       |
| Rolfe Canal Hydroelectric Project .....                                           | 13-26       |
| Fort Halifax Hydroelectric Station.....                                           | 13-27       |
| York Haven Hydroelectric Project .....                                            | 13-28       |
| Hadley Falls Hydroelectric Project .....                                          | 13-30       |
| Puntledge Generating Station .....                                                | 13-31       |
| Rocky Reach Dam .....                                                             | 13-32       |
| Seton Creek .....                                                                 | 13-32       |
| Case Studies – Strobe Light – Cage and Open Water Tests.....                      | 13-33       |
| Dworshak Dam.....                                                                 | 13-33       |
| Kingsford Hydroelectric Project.....                                              | 13-35       |
| Hiram M. Chittenden Locks .....                                                   | 13-36       |
| Roza Diversion Dam .....                                                          | 13-38       |
| Ludington Pumped Storage .....                                                    | 13-39       |
| R. H. Saunders Generating Station.....                                            | 13-40       |
| Lake Oahe.....                                                                    | 13-41       |
| Grand Coulee Dam .....                                                            | 13-42       |
| Case Studies – Strobe Light – Laboratory Studies .....                            | 13-44       |
| Laboratory Study - Saimaa Fisheries Research and Aquaculture Station, Finland ... | 13-44       |
| Laboratory Study – Pacific Northwest National Laboratory (PNNL).....              | 13-46       |
| Laboratory Study – University of Maryland .....                                   | 13-47       |
| Laboratory Study – San Onofre Nuclear Generating Station .....                    | 13-48       |
| Laboratory Study – Lee County Hyacinth Control District.....                      | 13-49       |

|                                                                                                                                                                  |             |
|------------------------------------------------------------------------------------------------------------------------------------------------------------------|-------------|
| Laboratory Study - Marine Biology Unit at Fawley, U.K. ....                                                                                                      | 13-50       |
| Laboratory Study – EPRI/University of Washington.....                                                                                                            | 13-50       |
| Laboratory Study – EPRI/University of Iowa .....                                                                                                                 | 13-52       |
| Laboratory Study, McIninch and Hocutt .....                                                                                                                      | 13-52       |
| Laboratory Study – Ontario Hydro .....                                                                                                                           | 13-53       |
| Laboratory Study - Simon Fraser University .....                                                                                                                 | 13-53       |
| Case Studies – Mercury Light – Hydroelectric Field Tests .....                                                                                                   | 13-55       |
| Weldon Dam, Mattaceunk Project.....                                                                                                                              | 13-55       |
| Various Dutch Stations and Water Bodies .....                                                                                                                    | 13-56       |
| York Haven Hydroelectric Project .....                                                                                                                           | 13-57       |
| Poutès Dam .....                                                                                                                                                 | 13-57       |
| Wanapum Dam .....                                                                                                                                                | 13-57       |
| Wapatox Canal Fish Screening Facility .....                                                                                                                      | 13-58       |
| Hadley Falls Hydroelectric Project .....                                                                                                                         | 13-60       |
| Annapolis Tidal Generating Station.....                                                                                                                          | 13-61       |
| Bellows Falls Hydroelectric Project .....                                                                                                                        | 13-61       |
| Priest Rapids Dam .....                                                                                                                                          | 13-62       |
| Cabot Station .....                                                                                                                                              | 13-62       |
| Case Studies – Mercury Lights – Cage Studies.....                                                                                                                | 13-63       |
| Kingsford Hydroelectric Station .....                                                                                                                            | 13-63       |
| Case Studies – Mercury Lights – Laboratory Studies .....                                                                                                         | 13-63       |
| Laboratory Study – EPRI/University of Washington.....                                                                                                            | 13-63       |
| Laboratory Study – Ontario Hydro .....                                                                                                                           | 13-64       |
| Case Studies – Other Light – Hydroelectric Field Tests .....                                                                                                     | 13-65       |
| Richard B. Russell Pumped Storage Project .....                                                                                                                  | 13-65       |
| Halsou Hydroelectric Plant.....                                                                                                                                  | 13-65       |
| Various Hydroelectric Projects in the Northeast – Weldon Dam, Mattaceunk<br>Hydroelectric Project, Rolfe Canal, Pejepscot Hydroelectric Project, Cabot Station.. | 13-66       |
| Rosa Diversion Dam .....                                                                                                                                         | 13-66       |
| Case Studies – Other Light – Cage Tests.....                                                                                                                     | 13-67       |
| Kingsford Hydroelectric Project.....                                                                                                                             | 13-67       |
| Case Studies – Other Light – Laboratory Studies.....                                                                                                             | 13-67       |
| Laboratory Study – University of Maryland .....                                                                                                                  | 13-67       |
| Laboratory Study - Marine Biology Unit, Fawley, UK .....                                                                                                         | 13-68       |
| Laboratory Study – EPRI/University of Washington.....                                                                                                            | 13-68       |
| Laboratory Study – San Onofre Nuclear Generating Station .....                                                                                                   | 13-69       |
| Laboratory Study – South Dakota State University .....                                                                                                           | 13-70       |
| <b>14 SOUND .....</b>                                                                                                                                            | <b>14-1</b> |
| Introduction .....                                                                                                                                               | 14-1        |
| Sound.....                                                                                                                                                       | 14-1        |
| Infrasound .....                                                                                                                                                 | 14-8        |

|                                                                                                                           |       |
|---------------------------------------------------------------------------------------------------------------------------|-------|
| Case Studies – Sound – CWIS Field Trials .....                                                                            | 14-11 |
| Doel Nuclear Power Plant, Scheldt Estuary, Belgium .....                                                                  | 14-11 |
| James A. Fitzpatrick Power Plant .....                                                                                    | 14-12 |
| Salem Generating Station .....                                                                                            | 14-13 |
| Arthur Kill Generating Station .....                                                                                      | 14-15 |
| Case Studies – Sound – Other Applications .....                                                                           | 14-16 |
| Crescent and Visher Ferry Hydroelectric Project .....                                                                     | 14-16 |
| Kingsford Hydroelectric Project .....                                                                                     | 14-18 |
| White Rapids Hydroelectric Project .....                                                                                  | 14-19 |
| Hiram M. Chittendon Locks .....                                                                                           | 14-19 |
| Richard B. Russell Pumped Storage Project .....                                                                           | 14-21 |
| Pejepscot Hydroelectric Project .....                                                                                     | 14-22 |
| Racine Hydroelectric Plant .....                                                                                          | 14-22 |
| Berrien Springs Hydroelectric Project and Buchanan Hydro Project .....                                                    | 14-23 |
| Georgiana Slough .....                                                                                                    | 14-24 |
| Wilkins Slough Pumping Station .....                                                                                      | 14-26 |
| Institute of Freshwater Ecology’s River Laboratories, Frome River, Dorset, UK and<br>Blantyre Hydroelectric Station ..... | 14-26 |
| Bonneville Dam .....                                                                                                      | 14-27 |
| Fort Halifax Hydroelectric Project .....                                                                                  | 14-27 |
| York Haven Hydroelectric Project .....                                                                                    | 14-28 |
| Vernon Hydroelectric Project .....                                                                                        | 14-28 |
| Hadley Falls Hydroelectric Project .....                                                                                  | 14-29 |
| Lennox Generating Station .....                                                                                           | 14-30 |
| Seton Hydroelectric Station .....                                                                                         | 14-30 |
| Allegheny Reservoir .....                                                                                                 | 14-31 |
| Arthur Kill Generating Station .....                                                                                      | 14-31 |
| Cage Tests – NYPA and ESEERCO .....                                                                                       | 14-32 |
| Pickering Nuclear Generating Station .....                                                                                | 14-33 |
| Manimota Bay, Japan .....                                                                                                 | 14-34 |
| Laboratory Study - Kinectrics .....                                                                                       | 14-34 |
| Case Studies – Infrasound – CWIS Application .....                                                                        | 14-35 |
| Lake Borrevann, Norway; Tihange Nuclear Power Plant, River Muese, Belgium .....                                           | 14-35 |
| Annapolis Tidal Generation Station .....                                                                                  | 14-36 |
| Case Studies – Infrasound – Other Applications .....                                                                      | 14-39 |
| Kingsford Hydroelectric Project .....                                                                                     | 14-39 |
| McNary Dam .....                                                                                                          | 14-39 |
| Roza Dam .....                                                                                                            | 14-39 |
| Rolfe Canal Hydroelectric Project .....                                                                                   | 14-40 |
| Small Hydroelectric Intake, Sandvikselven, Norway .....                                                                   | 14-42 |
| Laboratory and Field Study, River Imsa, Norway .....                                                                      | 14-42 |

|                                                                              |             |
|------------------------------------------------------------------------------|-------------|
| Hiram M. Chittenden Locks .....                                              | 14-44       |
| Sommaroyhamn, Norway .....                                                   | 14-44       |
| Laboratory Study – Pacific Northwest National Laboratory (PNNL).....         | 14-45       |
| Laboratory Study, Oregon State University.....                               | 14-46       |
| Laboratory Study, Norway.....                                                | 14-46       |
| <b>15 AIR BUBBLE CURTAINS .....</b>                                          | <b>15-1</b> |
| Introduction .....                                                           | 15-1        |
| Case Studies – CWIS Field Tests.....                                         | 15-2        |
| Indian Point Generating Station .....                                        | 15-2        |
| Roseton Generating Station.....                                              | 15-5        |
| Pickering Nuclear Generating Station .....                                   | 15-5        |
| Case Studies – Hydroelectric Field Tests .....                               | 15-5        |
| White Rapids Hydroelectric Project.....                                      | 15-5        |
| Four Mile Hydroelectric Project .....                                        | 15-6        |
| Seton Hydroelectric Station.....                                             | 15-6        |
| Heysham 1 and 2 Power Stations .....                                         | 15-6        |
| Case Studies – Laboratory Studies.....                                       | 15-7        |
| River Frome, UK .....                                                        | 15-7        |
| Laboratory Studies, Various Locations .....                                  | 15-10       |
| Laboratory Study – Alden.....                                                | 15-11       |
| <b>16 HYBRID BEHAVIORAL BARRIERS.....</b>                                    | <b>16-1</b> |
| Case Studies – Field Evaluations .....                                       | 16-1        |
| Delaware Bay – PSEG/Alden Research Laboratory .....                          | 16-1        |
| Lambton Generating Station .....                                             | 16-7        |
| Plant Barry Generating Station .....                                         | 16-9        |
| Case Studies – Laboratory Evaluations .....                                  | 16-12       |
| Laboratory Study – PSEG/Alden Research Laboratory .....                      | 16-12       |
| Laboratory/Hatchery Facility, Illinois Department of Natural Resources ..... | 16-19       |
| Laboratory Study - Kinetrics .....                                           | 16-21       |
| <b>17 OTHER FISH PROTECTION TECHNOLOGIES .....</b>                           | <b>17-1</b> |
| Introduction .....                                                           | 17-1        |
| Inclined Plane Screen .....                                                  | 17-1        |
| Filtrex Candles .....                                                        | 17-1        |
| Case Studies – Field Applications.....                                       | 17-1        |
| Taunton River, Dighton, MA .....                                             | 17-1        |
| Case Studies – Laboratory.....                                               | 17-4        |
| Alden Research Laboratory .....                                              | 17-4        |
| Guidance Walls.....                                                          | 17-12       |
| Turbulence .....                                                             | 17-12       |
| Electric Barriers.....                                                       | 17-13       |

|                                           |             |
|-------------------------------------------|-------------|
| Case Studies – Field Evaluation .....     | 17-13       |
| Chicago Sanitary and Shipyard Canal ..... | 17-13       |
| Case Studies – Laboratory Evaluation..... | 17-15       |
| <b>18 REFERENCES .....</b>                | <b>18-1</b> |

# LIST OF FIGURES

|                                                                                                                                                                                   |       |
|-----------------------------------------------------------------------------------------------------------------------------------------------------------------------------------|-------|
| Figure 2-1 Flush mounted traveling screen (modified from Mussalli et al. 1978).....                                                                                               | 2-3   |
| Figure 2-2 Schematic of a conventional traveling water screen .....                                                                                                               | 2-4   |
| Figure 2-3 Section of a traveling water screen modified for fish protection<br>(Ronafalvy et al. 2000).....                                                                       | 2-5   |
| Figure 2-4 Section of an old fish basket design (left) and a new fish basket design (right)<br>illustrating the flow field created by each (Ronafalvy et al. 2000) .....          | 2-5   |
| Figure 2-5 Schematic of a Beaudrey WIP screen (Source: Beaudrey).....                                                                                                             | 2-7   |
| Figure 2-6 Modified dual-flow screen at Dunkirk Station (Beak 1988).....                                                                                                          | 2-16  |
| Figure 2-7 Somerset Station fish collection table (McLaren and Tuttle 2000) .....                                                                                                 | 2-32  |
| Figure 2-8 Schematic diagram of the Belle River Power Plant sampling stations<br>(Freshwater Physicians, Inc. 1991).....                                                          | 2-41  |
| Figure 2-9 Plan view of Roseton cooling water intake structure (modified from LMS 1991)....                                                                                       | 2-43  |
| Figure 2-10 Schematic of a dual-flow traveling intake screen (courtesy of U.S. Filter).....                                                                                       | 2-44  |
| Figure 2-11 Section view of Roseton dual-flow traveling screen (LMS 1991).....                                                                                                    | 2-45  |
| Figure 2-12 Brayton Point angled traveling screen intake configuration (Davis et al. 1988)....                                                                                    | 2-48  |
| Figure 2-13 No-well screen (SWEC 1980).....                                                                                                                                       | 2-52  |
| Figure 2-14 Section view of Indian Point Generating Station Unit 1 CWIS (EA 1977).....                                                                                            | 2-58  |
| Figure 2-15 Center-flow (Passavant) screen (Murray and Jinette 1978) .....                                                                                                        | 2-77  |
| Figure 2-16 Bowline Point Station intake structure (King et al. 1978).....                                                                                                        | 2-79  |
| Figure 2-17 Section view of 100-N intake structure (Page et al. 1977) .....                                                                                                       | 2-85  |
| Figure 2-18 Section view of HGP intake structure (Page et al. 1977) .....                                                                                                         | 2-86  |
| Figure 2-19 Schimetic of the Providence River showing Manchester Street Station and<br>approximate location of high- and low-pressure fish return lines (Marine Research 1997) .. | 2-89  |
| Figure 2-20 Hydrolox™ screen installed at the Barrett Generating Station, 2007 .....                                                                                              | 2-95  |
| Figure 2-21 Passavant-Geiger Multi-Disc™ Screen .....                                                                                                                             | 2-99  |
| Figure 2-22 Passavant-Geiger fish collection details.....                                                                                                                         | 2-100 |
| Figure 2-23 Image of Geiger screen installed at Fort Calhoun Station .....                                                                                                        | 2-104 |
| Figure 2-24 Test flume including isolation screen, traveling water screen, collection<br>trough, and collection net.....                                                          | 2-119 |
| Figure 2-25 Hydrolox Screen™ installed in fish testing flume.....                                                                                                                 | 2-125 |
| Figure 2-26 Plan and section of prototype-scale test flume (EPRI 2010a) .....                                                                                                     | 2-131 |
| Figure 2-27 Test flume for prototype-scale screen testing showing the three test<br>screens (EPRI 2009b).....                                                                     | 2-132 |
| Figure 2-28 Ovivo screen collection system and PIT tag antenna locations.....                                                                                                     | 2-135 |
| Figure 2-29 Common carp total survival on the OVIVO screen (left) and WIP screen<br>(right).....                                                                                  | 2-136 |
| Figure 2-30 Golden shiner total survival on the OVIVO screen (left) and WIP screen<br>(right).....                                                                                | 2-136 |
| Figure 2-31 Time-to-impingement frequency (left) and length relationship (right) for<br>bluegill during Week 1 testing. ....                                                      | 2-138 |
| Figure 2-32 Time-to-impingement frequency (left) and length relationship (right) for<br>common carp during Week 1 testing. ....                                                   | 2-139 |

|                                                                                                                                                                                        |       |
|----------------------------------------------------------------------------------------------------------------------------------------------------------------------------------------|-------|
| Figure 2-33 Discharge line from the pump to the collection box (A) and inside view of the collection box (B) .....                                                                     | 2-142 |
| Figure 2-34 Prototype Beaudry WIP screen and pump .....                                                                                                                                | 2-143 |
| Figure 2-35 Adjusted survival for fathead minnow larvae using the Ricker model.....                                                                                                    | 2-144 |
| Figure 2-36 Taft Fisheries Research and Test Facility configured for the Phase II biological evaluation of the Beaudrey WIP screen.....                                                | 2-146 |
| Figure 2-37 Section view of fish return system testing loop with collection box at the 4 ft discharge height.....                                                                      | 2-149 |
| Figure 2-38 Configuration of collection box at each discharge height; underwater, 2 ft, and 4 ft. ....                                                                                 | 2-149 |
| Figure 2-39 Plan and section view of the Phase II fish return line testing facility.....                                                                                               | 2-152 |
| Figure 2-40 Stone (A), rough carpet (B), fiber (C) and smooth (not shown) trough substrate materials.....                                                                              | 2-153 |
| Figure 2-41 Plan and elevation views of the Phase III fish return testing facility .....                                                                                               | 2-155 |
| Figure 2-42 The surrogate debris group included mylar (A), wood chips (B), and tinsel (C) debris .....                                                                                 | 2-156 |
| Figure 2-43 The non-traditional debris group included plastic media (A), plywood pieces (B), and beads (C) debris .....                                                                | 2-156 |
| Figure 3-1 Brunswick Plant layout and fish diversion barrier screen (Carolina Power and Light 1985b).....                                                                              | 3-2   |
| Figure 3-2 Plan and side conceptual views of Farmer screen (Mesa 2012).....                                                                                                            | 3-4   |
| Figure 4-1 Typical drum screen (EPRI 1986a) .....                                                                                                                                      | 4-2   |
| Figure 5-1 Cylindrical wedgewire screen panel detail (modified from EPRI) .....                                                                                                        | 5-2   |
| Figure 5-2 Cylindrical wedgewire screen intake (courtesy of Johnson Screens).....                                                                                                      | 5-2   |
| Figure 5-3 Wedgewire screen intake at the Logan Generating Plant (Ehrler and Raifsnider 2000).....                                                                                     | 5-3   |
| Figure 5-4 Wedgewire intake system at Eddystone Station (Veneziale 1991) .....                                                                                                         | 5-5   |
| Figure 5-5 Wedgewire screen intake system — Jeffrey Energy Center (Johnson and Ettema 1988) .....                                                                                      | 5-7   |
| Figure 5-6 Drawing of a bulkhead-mounted screen with cut away of wedgewire configuration (Weisberg et al. 1987) .....                                                                  | 5-8   |
| Figure 5-7 Fish testing facility and approximate location of cylindrical wedgewire screens (EPRI 2003).....                                                                            | 5-17  |
| Figure 5-8 2001 wedgewire screen test facility (EPRI 2003) .....                                                                                                                       | 5-17  |
| Figure 5-9 2002 wedgewire screen test facility (EPRI 2003) .....                                                                                                                       | 5-18  |
| Figure 5-10 Johnson T-12 cylindrical wedgewire screen (white lines delineate sections of the screen for which impingement locations were recorded) (EPRI 2003) .....                   | 5-19  |
| Figure 5-11 Schematic diagram of wedgewire test flume (Hanson et al. 1977).....                                                                                                        | 5-22  |
| Figure 5-12 Test facility in plan and elevation view (EPRI 2005).....                                                                                                                  | 5-27  |
| Figure 5-13 Floating test facility (barge) – plan view (Alden 2010).....                                                                                                               | 5-45  |
| Figure 5-14 Floating test facility (barge) – elevation view (Alden 2010) .....                                                                                                         | 5-45  |
| Figure 5-15 Photographs showing the aluminum sleeve used to decrease the open area of the 2.0-mm wedgewire screen (left) and the geometry of the control intake cone (Alden 2010)..... | 5-46  |
| Figure 5-16 Floating test facility (barge) with alternative sampling equipment. ....                                                                                                   | 5-46  |
| Figure 5-17 Floating test facility (barge with standard sampling equipment) (Alden 2010) .....                                                                                         | 5-47  |



|                                                                                                                                                                                                                                                                                                                                                    |      |
|----------------------------------------------------------------------------------------------------------------------------------------------------------------------------------------------------------------------------------------------------------------------------------------------------------------------------------------------------|------|
| Figure 5-18 Test module with wire design (University of Iowa, Institute of Hydraulic Research) .....                                                                                                                                                                                                                                               | 5-51 |
| Figure 5-19 MMWD pilot plant cylindrical narrow slot intake .....                                                                                                                                                                                                                                                                                  | 5-53 |
| Figure 6-1 Dallman barrier net installation 2003 .....                                                                                                                                                                                                                                                                                             | 6-7  |
| Figure 6-2 Bowline Point barrier net configuration (LMS 1978) .....                                                                                                                                                                                                                                                                                | 6-8  |
| Figure 6-3 Bowline Point fine-mesh barrier net configuration (LMS 1994) .....                                                                                                                                                                                                                                                                      | 6-9  |
| Figure 6-4 Chalk Point barrier net configuration (Loos 1986a, b) .....                                                                                                                                                                                                                                                                             | 6-12 |
| Figure 6-5 Baker River aerial photograph of barrier net .....                                                                                                                                                                                                                                                                                      | 6-15 |
| Figure 6-6 Ludington aerial photograph of barrier net .....                                                                                                                                                                                                                                                                                        | 6-19 |
| Figure 6-7 Pine barrier net .....                                                                                                                                                                                                                                                                                                                  | 6-20 |
| Figure 6-8 Brule barrier net .....                                                                                                                                                                                                                                                                                                                 | 6-21 |
| Figure 6-9 Banks Lake fish barrier net – aerial photograph .....                                                                                                                                                                                                                                                                                   | 6-23 |
| Figure 6-10 Estimated annual fish impingement at the J. R. Whiting Plant from 1978 through 1984 (CPC 1984) .....                                                                                                                                                                                                                                   | 6-27 |
| Figure 7-1 Close-up of perforated AFB material (courtesy of Alden) .....                                                                                                                                                                                                                                                                           | 7-1  |
| Figure 7-2 Location of the Lovett Generating Station on the Hudson River, NY (LMS 1996b) .....                                                                                                                                                                                                                                                     | 7-2  |
| Figure 7-3 Site plan of the AFB deployment at the Lovett Generating Station showing sampling locations for entrainment sampling conducted between 1995 and 1999 (LMS 1998a,b) .....                                                                                                                                                                | 7-3  |
| Figure 7-4 Site plan of the AFB deployment at the Lovett Generating Station showing sampling locations for entrainment sampling conducted between 2004 and 2006 (ASA 2004) .....                                                                                                                                                                   | 7-3  |
| Figure 7-5 Appearance of AFB pieces after 11, 20 and 29 days of exposure (moving from left to right) to water in Bowline Pond at a depth of 3 ft (Henderson et al. 2001) .....                                                                                                                                                                     | 7-8  |
| Figure 7-6 Hatching jars used in American shad egg impingement trials at the New York State Department of Environmental Conservation (NYSDEC) (photo courtesy Ed Radle, NYSDEC) .....                                                                                                                                                              | 7-9  |
| Figure 7-7 Small test flume used in headloss and debris load testing (EPRI 2004) .....                                                                                                                                                                                                                                                             | 7-10 |
| Figure 7-8 Large flume used in the investigation of the effects of ambient sweeping currents on headloss .....                                                                                                                                                                                                                                     | 7-10 |
| Figure 7-9 Biological testing facility comprised of 14 small acrylic test flumes (EPRI 2004) .....                                                                                                                                                                                                                                                 | 7-11 |
| Figure 9-1 Monroe Power Plant section view of fish pump system (Detroit Edison 1975) .....                                                                                                                                                                                                                                                         | 9-8  |
| Figure 9-2 Schematic of the Red Bluff Research Pumping Plant, Sacramento River, CA .....                                                                                                                                                                                                                                                           | 9-10 |
| Figure 9-3 Cut-away perspective of Archimedes lifts in bays 1 and 2 of the Red Bluff Research Pumping Plant, Sacramento River, California .....                                                                                                                                                                                                    | 9-11 |
| Figure 9-4 Cut-away perspective of the Hidrostal pump in bay 3 of the Red Bluff Research Pumping Plant, Sacramento River, California .....                                                                                                                                                                                                         | 9-11 |
| Figure 9-5 Mean plasma cortisol concentrations (ng/mL; vertical bars represent 1 SE) of Chinook salmon (A) at 0, 1, 3, 6, 12, and 24 hrs after passage through Archimedes lifts during 1998 (706 fish), (B) and 0, 1, 1.5, 3, 6, and 12 hrs after passage through Archimedes lifts (720 fish) or (C) a Hidrostal pump (710 fish) during 1999. .... | 9-16 |
| Figure 9-6 Cross-sectional view of the Hidrostal pump and fish injection ports (the fish protective impeller shroud is not shown in this drawing) (Helfrich et al. 2001) .....                                                                                                                                                                     | 9-18 |
| Figure 9-7 Cross-sectional view through the laboratory testing facility (Patrick and Sim 1985) .....                                                                                                                                                                                                                                               | 9-25 |

|                                                                                                                                                                                                                                                                                 |       |
|---------------------------------------------------------------------------------------------------------------------------------------------------------------------------------------------------------------------------------------------------------------------------------|-------|
| Figure 9-8 Jet pump test facility (ESEERCO 1981b).....                                                                                                                                                                                                                          | 9-27  |
| Figure 9-9 Hidrostal pump test facility (ESEERCO 1981b).....                                                                                                                                                                                                                    | 9-28  |
| Figure 10-1 Oswego Unit 6 angled screen layout (LMS 1992).....                                                                                                                                                                                                                  | 10-3  |
| Figure 10-2 Oswego angled screen intake system dewatered (courtesy of Alden Research Laboratory, Inc.).....                                                                                                                                                                     | 10-4  |
| Figure 10-3 Brayton Point Station Unit 4 angled screen intake structure fish return systems (Davis et al. 1988).....                                                                                                                                                            | 10-5  |
| Figure 10-4 Danskammer angled screen system layout (LMS 1985).....                                                                                                                                                                                                              | 10-8  |
| Figure 10-5 White River angled screen system — plan view (Dorratcague et al. 1996).....                                                                                                                                                                                         | 10-9  |
| Figure 10-6 White River screen system — section view (Dorratcague et al. 1996).....                                                                                                                                                                                             | 10-10 |
| Figure 10-7 White River angled screen diversion system (courtesy of U.S. Filter — Johnson Screen).....                                                                                                                                                                          | 10-11 |
| Figure 10-8 Angled screen flume arrangement (plan) (Taft and Isakson 1983).....                                                                                                                                                                                                 | 10-13 |
| Figure 10-9 Test tank (A) showing (a) video camera, (b) test chamber, (c) velocity meter, (d) cooling unit, and (e) propeller system. ....                                                                                                                                      | 10-15 |
| Figure 10-10 Total efficiency versus length for 1.5 mm mesh 1978 striped bass diversion study (Taft et al. 1981b).....                                                                                                                                                          | 10-22 |
| Figure 10-11 Total efficiency versus length for 2.5 mm mesh 1978 striped bass diversion study (Taft et al. 1981b).....                                                                                                                                                          | 10-23 |
| Figure 10-12 Diagram of the open-topped, glass water flume swimming chamber and bypass channel.....                                                                                                                                                                             | 10-30 |
| Figure 10-13 Flow maps of water velocities at middepth (8 cm) in the high-velocity, high-bypass (60 cm/s with a 72 cm/s bypass) and intermediate-velocity (32 cm/sec) treatments near the fish screen.....                                                                      | 10-30 |
| Figure 10-14 Mean ( $\pm$ SE) splittail hematocrit (%), plasma glucose (g/L), and lactate concentrations (g/L) at rest and without flume exposure (-2 h), immediately after swimming in the flume (0 h), and during recovery (0.5, 2, and 24h) for each velocity treatment..... | 10-33 |
| Figure 11-1 Modular inclined screen (Taft et al. 1995).....                                                                                                                                                                                                                     | 11-2  |
| Figure 11-2 Eicher Screen (EPRI 1992a).....                                                                                                                                                                                                                                     | 11-3  |
| Figure 11-3 Schematic of modular inclined screens (Taft et al 1997).....                                                                                                                                                                                                        | 11-4  |
| Figure 11-4 Puntledge Eicher Screen System (Smith 1997).....                                                                                                                                                                                                                    | 11-5  |
| Figure 11-5 Main features and operation of a typical high-velocity inclined profile-bar screen (A). The section view (B) depicts the details of profile-bar position, arrangement, and function (Wahl 2001).....                                                                | 11-9  |
| Figure 12-1 Orientation of angled bar racks and louvers slats. ....                                                                                                                                                                                                             | 12-1  |
| Figure 12-2 Schematic diagram of the Grand Falls Power Canal, showing louver line, bypass, and dam (Scruton et al. 2003).....                                                                                                                                                   | 12-3  |
| Figure 12-3 Water velocity profiles along the louver array at depths of 0.5, 1.0, 1.5, and 2.0m in 1998.....                                                                                                                                                                    | 12-4  |
| Figure 12-4 Schematic diagram of the louver line and bypass facility indicating detection cells (shaded circles) of 13 underwater antennae of the DSP telemetry system, as deployed in 2000.....                                                                                | 12-5  |
| Figure 12-5 Fish guidance efficiencies (unadjusted) for Atlantic salmon smolts for the 5 years of monitoring, 1997 to 2001 (Scruton et al. 2003).....                                                                                                                           | 12-6  |
| Figure 12-6 Holyoke louver system (Stira and Robinson 1997).....                                                                                                                                                                                                                | 12-9  |

|                                                                                                                                                                                                                                                                                                                                                                                                                                        |       |
|----------------------------------------------------------------------------------------------------------------------------------------------------------------------------------------------------------------------------------------------------------------------------------------------------------------------------------------------------------------------------------------------------------------------------------------|-------|
| Figure 12-7 Holyoke louver system (photo courtesy of Alden) .....                                                                                                                                                                                                                                                                                                                                                                      | 12-10 |
| Figure 12-8 Red Bluff Diversion Dam and associated fish passage facilities (Vogel et al. 1990) .....                                                                                                                                                                                                                                                                                                                                   | 12-11 |
| Figure 12-9 Louver screening efficiency for young Chinook salmon released into the Tehama-Colusa Canal Headworks (Vogel et al. 1990).....                                                                                                                                                                                                                                                                                              | 12-12 |
| Figure 12-10 Plan view of fish testing facility configured for tests with the bar rack and louver arrays angled at 45 degrees to the approach flow (EPRI 2001) .....                                                                                                                                                                                                                                                                   | 12-13 |
| Figure 12-11 Plan view of fish testing facility configured for tests with the bar rack and louver arrays angled at 15 degrees to the approach flow (EPRI 2001) .....                                                                                                                                                                                                                                                                   | 12-13 |
| Figure 12-12 Louver system at SONGS (EPRI 1987) .....                                                                                                                                                                                                                                                                                                                                                                                  | 12-25 |
| Figure 13-1 Roseton intake structure behavioral barriers — section (EPRI 1999) .....                                                                                                                                                                                                                                                                                                                                                   | 13-20 |
| Figure 13-2 1991 forebay and float positions, York Haven Hydroelectric Project (Taft et al. 2001).....                                                                                                                                                                                                                                                                                                                                 | 13-29 |
| Figure 13-3 1992 forebay and float positions, York Haven Hydroelectric Project (Taft et al 2001).....                                                                                                                                                                                                                                                                                                                                  | 13-30 |
| Figure 13-4 Vertical distance of yearling coho salmon above strobe lights that were flashing five times/sec for 0 to 10 min (left) and the same distances for schools during control treatments without strobe light (right) (Ploskey and Johnson 2001). .....                                                                                                                                                                         | 13-37 |
| Figure 13-5 Deployment of strobe lights and hydroacoustic transducers from fixed barge (Simmons et al. 2002).....                                                                                                                                                                                                                                                                                                                      | 13-43 |
| Figure 13-6 Percentage of Kokanee and sockeye salmon that responded to an overhead shadow after strobe light exposure for various amounts of time as a function of time after exposure. ....                                                                                                                                                                                                                                           | 13-55 |
| Figure 13-7 Modified light orientation Wapatox — plan view (EPRI 1990) .....                                                                                                                                                                                                                                                                                                                                                           | 13-59 |
| Figure 14-1 Locations of eight ultrasonic (122–128 kHz) projectors, a horizontally aimed, 500-kHz acoustic Doppler current profilers (ADCPs), 420-kHz, horizontally-aimed single-beam transducers and vertically-aimed split-beam transducers (mounted from the river bottom), and mobile hydroacoustic survey transects used for the 2008 evaluation of high-frequency sound at the Crescent Project (Dunning and Gurshin 2012). .... | 14-17 |
| Figure 14-2 Mean number of adult eels within 1 m of the experimental sound projector during attraction tests (Patrick et al. 2001) .....                                                                                                                                                                                                                                                                                               | 14-35 |
| Figure 14-3 Sketch of the River Imsa at the site of the fish trap. ....                                                                                                                                                                                                                                                                                                                                                                | 14-43 |
| Figure 15-1 Cross section of air bubbler array in front of intake bay 12 at Indian Point Unit 1.....                                                                                                                                                                                                                                                                                                                                   | 15-3  |
| Figure 16-1 Plan view of the sampling equipment and test area (PSEG 2005).....                                                                                                                                                                                                                                                                                                                                                         | 16-3  |
| Figure 16-2 Avoidance probabilities (with 95% confidence intervals) by species and family... 16-6                                                                                                                                                                                                                                                                                                                                      |       |
| Figure 16-3 Layout of the strobe light-acoustic hybrid system installed at Lambton (Cord et al 2007).....                                                                                                                                                                                                                                                                                                                              | 16-8  |
| Figure 16-4 Location of the strobe light frames within the stoplog slots of Units 4-5 CWIS... 16-10                                                                                                                                                                                                                                                                                                                                    |       |
| Figure 16-5 Locations of the 3 sonic and 5 ultrasonic sound frequency transducers inside the intake forebay of the Units 4-5 CWIS. ....                                                                                                                                                                                                                                                                                                | 16-10 |
| Figure 16-6 Overhead schematic of the test facility (PSEG 2003) .....                                                                                                                                                                                                                                                                                                                                                                  | 16-14 |
| Figure 16-7 Section and overhead view of the proposed sound system at Salem (PSEG 2003).....                                                                                                                                                                                                                                                                                                                                           | 16-19 |

|                                                                                                                                                                                                                             |       |
|-----------------------------------------------------------------------------------------------------------------------------------------------------------------------------------------------------------------------------|-------|
| Figure 16-8 Mean number ( $\pm$ SD) of bighead carp attempts and repels observed in the raceway with the activated sound and air system averaged across the three trials (adapted from Figure 1 in Taylor et al. 2005)..... | 16-20 |
| Figure 16-9 Mean number ( $\pm$ SD) of bighead carp found above the barrier. ....                                                                                                                                           | 16-21 |
| Figure 16-10 Efficiency comparisons for deterrence devices for five species (Patrick et al. 2006b).....                                                                                                                     | 16-22 |
| Figure 16-11 Comparison of fish (5 species) positions beyond 1.2 m-zone from deterrence devices (Patrick et al. 2006b) .....                                                                                                | 16-22 |
| Figure 17-1 Top candle array of IMOD shown with (left) and without (right) the impingement enclosure box (Normandeau 2007).....                                                                                             | 17-2  |
| Figure 17-2 Filtrex receiver box of IMOD (Normandeau 2007).....                                                                                                                                                             | 17-3  |
| Figure 17-3 Six individual Filtrex filter candles installed in the laboratory test facility. ....                                                                                                                           | 17-5  |
| Figure 17-4 Schematic with approximate distances between system components and egg and larvae release and collection locations and photograph of Filtrex Test Facility (Alden 2007) .....                                   | 17-6  |
| Figure 17-5 Arrangement of antennas and hydrophones at the barrier (Sparks et al. 2010).....                                                                                                                                | 17-14 |
| Figure 17-6 Overhead schematic of electric barrier test facility (Dawson et al. 2006).....                                                                                                                                  | 17-16 |

## LIST OF TABLES

|                                                                                                                                                                                                                                  |      |
|----------------------------------------------------------------------------------------------------------------------------------------------------------------------------------------------------------------------------------|------|
| Table 1-1 Category groupings for fish protection technologies based on mode of action .....                                                                                                                                      | 1-5  |
| Table 2-1 Summary of information on modified coarse and fine-mesh traveling screen installations and studies .....                                                                                                               | 2-8  |
| Table 2-2 Dual-flow screen post-impingement survival study results — Dunkirk Steam Station (August 1990–January 1991) (Lindsay 1991) .....                                                                                       | 2-15 |
| Table 2-3 Dunkirk Station early winter survival testing results (Beak 2000a) .....                                                                                                                                               | 2-17 |
| Table 2-4 Dunkirk Station impingement survival testing results for target species 1998–1999 (Beak 2000a) .....                                                                                                                   | 2-19 |
| Table 2-5 Comparison of 24-hr impingement survival rates of target fish species at Dunkirk Station before (1987 and 1990–1991) and after (1998–1999) installation of the prototype dual-flow traveling screen (Beak 2000a) ..... | 2-20 |
| Table 2-6 Collection efficiency results for Centrarchids (Beak 2000b) .....                                                                                                                                                      | 2-24 |
| Table 2-7 Collection efficiency results for emerald shiner and rainbow smelt at the Huntley Station (5 psi only) (Beak 2000b) .....                                                                                              | 2-24 |
| Table 2-8 Numbers of naturally impinged fish collected in fish and debris troughs at Huntley Station (Beak 2000b) .....                                                                                                          | 2-24 |
| Table 2-9 Results of impingement survival testing, Huntley Station, January, 1999 (Beak 2000b) .....                                                                                                                             | 2-25 |
| Table 2-10 Results of impingement survival testing, Huntley Station, October, 1999 (Beak 2000b) .....                                                                                                                            | 2-26 |
| Table 2-11 Results of 1997–1998 impingement survival study — Salem Generating Station (Heimbuch 1999) .....                                                                                                                      | 2-28 |
| Table 2-12 Estimated survival rates for original and modified screen at Salem Generating Station (Heimbuch 1999) .....                                                                                                           | 2-29 |
| Table 2-13 Initial and 96-hr seasonal survival rates of impinged fish at Somerset Station for frequently impinged species (McLaren and Tuttle 2000) .....                                                                        | 2-33 |
| Table 2-14 Twenty-four hour post-impingement survival of fish collected from one unmodified and two Ristroph-modified dual-flow screens at the Arthur Kill Generating Station (Consolidated Edison Company 1996) .....           | 2-36 |
| Table 2-15 Unit 5 conventional vertical traveling screen oost-impingement survival summary Oswego Steam Station 1991 (LMS 1992) .....                                                                                            | 2-39 |
| Table 2-16 Seasonal post-impingement survival Roseton Generating Station (LMS 1991) ....                                                                                                                                         | 2-47 |
| Table 2-17 Impingement survival information — Brayton Point Station Unit 4 (Oct. 1984–March 1986) (Davis et al. 1988) .....                                                                                                      | 2-49 |
| Table 2-18 Initial, latent, and overall survival by taxa and lifestage for 1984–1987 Prairie Island Generating Plant (Kuhl and Mueller 1988) .....                                                                               | 2-51 |
| Table 2-19 Fish eggs — percent survival and hatchability Big Bend Plant (Taft et al. 1981a) .....                                                                                                                                | 2-54 |
| Table 2-20 Fish larvae — percent initial and latent survival at Big Bend (Taft et al. 1981a) .....                                                                                                                               | 2-55 |
| Table 2-21 Decapod zoea — percent initial and latent survival at Big Bend (Taft et al. 1981a) .....                                                                                                                              | 2-55 |
| Table 2-22 Decapod megalops — percent initial and latent survival at Big Bend (Taft et al. 1981a) .....                                                                                                                          | 2-56 |

|                                                                                                                                                                                                                       |       |
|-----------------------------------------------------------------------------------------------------------------------------------------------------------------------------------------------------------------------|-------|
| Table 2-23 Comparison of initial survival (%) during the FMS survivability studies at Big Bend Station (Brueggemeyer et al. 1988) .....                                                                               | 2-57  |
| Table 2-24 Comparison of fish egg hatchability and latent 48 hr survival (%) during the prototype and FMS survivability studies (Brueggemeyer et al. 1988).....                                                       | 2-57  |
| Table 2-25 Survival (%) of fish collected from a Ristroph screen (fish sluice only) at Indian Point Unit 2 and held for 96 hrs in situ; August 15 through December 27, 1985 (CONED 1986).....                         | 2-60  |
| Table 2-26 Survival of fish collected from a Ristroph screen (fish sluice only) at Indian Point Unit 2 and held for 96 hrs in situ; November 8 through December 27, 1985 (ConEd 1986).....                            | 2-62  |
| Table 2-27 Initial and 96-hr survival for post-yolk-sac larvae and juveniles at Indian Point Generating Station (EA 1977).....                                                                                        | 2-64  |
| Table 2-28 Brunswick Station impingement survival study results: screen mortality — 1984 and 1985 (Carolina Power and Light 1985a) .....                                                                              | 2-67  |
| Table 2-29 Brunswick Station impingement survival study results: control mortality — 1984 and 1985 (Carolina Power and Light 1985a) .....                                                                             | 2-69  |
| Table 2-30 Initial and 84-hr survival by species, lifestage, and screenwash mode at the Danskammer Point Plant (EA 1982) .....                                                                                        | 2-72  |
| Table 2-31 Initial and 84-hr survival of control species, lifestage, and screenwash mode at the Danskammer Point Plant (EA 1982).....                                                                                 | 2-73  |
| Table 2-32 Mortality of winter flounder (SWEC 1981) .....                                                                                                                                                             | 2-75  |
| Table 2-33 Initial and 96-hr survival of white perch by screen operation mode at Bowline Point Plant (King et al. 1978) .....                                                                                         | 2-80  |
| Table 2-34 Initial and 96-hr survival of white perch and striped bass by screen operation mode at Bowline Point Plant (King et al. 1978).....                                                                         | 2-82  |
| Table 2-35 Immediate and 48-hr survival of impinged fish and macroinvertebrates at Oyster Creek Generating Station (Tatham et al. 1978) .....                                                                         | 2-84  |
| Table 2-36 Initial and 48-h survival rates by species.....                                                                                                                                                            | 2-90  |
| Table 2-37 Millstone Unit 3 sluiceway survival of the 10 most abundant species following various holding periods (NUSCO 1987).....                                                                                    | 2-91  |
| Table 2-38 Count and survival of fish impinged on the traveling screen at SGS (Miller 2007) .....                                                                                                                     | 2-92  |
| Table 2-39 Total number of the 15 most abundant species collected during impingement studies at H. A. Wagner Generating Station .....                                                                                 | 2-93  |
| Table 2-40 48-hr mortality by species, number of species collected, and size range by species.....                                                                                                                    | 2-96  |
| Table 2-41 Total collected and percent survival by species sampled during 2005-2006 at the Potomac River Generating Station (EPRI 2007).....                                                                          | 2-102 |
| Table 2-42 LIM survival percentages for the fall and spring season's most common species sampled at the Potomac River Generating Station and five other plants with modified traveling water screens (EPRI 2007)..... | 2-103 |
| Table 2-43 Initial survival and number of individuals included in survival estimates by species for monitoring at Fort Calhoun Station (EA 2011).....                                                                 | 2-105 |
| Table 2-44 Larval mean length passed versus mean length retained (LMS 1981).....                                                                                                                                      | 2-108 |
| Table 2-45 Adjusted mean impingement survival for each test species (LMS 1981) .....                                                                                                                                  | 2-110 |
| Table 2-46 Phase II impingement survival results (LMS 1981) .....                                                                                                                                                     | 2-115 |

|                                                                                                                                                                                                                                                               |       |
|---------------------------------------------------------------------------------------------------------------------------------------------------------------------------------------------------------------------------------------------------------------|-------|
| Table 2-47 48-hr mean percent survival of fish impinged on fine-mesh screens and control groups at the TVA Laboratory (Tomljanovich et al. 1977).....                                                                                                         | 2-118 |
| Table 2-48 Mean fork length (mm) ± standard error (SE), total number of fish tested (n), survival at 48 hrs after testing, and the 95% confidence intervals (CI) by species and velocity.....                                                                 | 2-122 |
| Table 2-49 Percent injury by species and velocity.....                                                                                                                                                                                                        | 2-123 |
| Table 2-50 Survival and injury rates (%) by species and duration of impingement .....                                                                                                                                                                         | 2-124 |
| Table 2-51 Summary of mortality rates by treatment condition .....                                                                                                                                                                                            | 2-126 |
| Table 2-52 Summary of injury rates by treatment condition .....                                                                                                                                                                                               | 2-127 |
| Table 2-53 Summary of scale loss rates by treatment condition .....                                                                                                                                                                                           | 2-128 |
| Table 2-54 Survival rate by species, velocity, and duration in table-top studies with 0.5 mm screen mesh (EPRI 2010a).....                                                                                                                                    | 2-130 |
| Table 2-55 Screen, mesh size, approach velocity and species tested during corresponding years. ....                                                                                                                                                           | 2-133 |
| Table 2-56 Percent of collected fish by species and week used for analyses (TTI=Time-to-impingement; SISL=Survival, injury and scale loss) .....                                                                                                              | 2-137 |
| Table 2-57 Number of fish assessed, conditions and percent survival, injury, and scale loss of <3% by species and week.....                                                                                                                                   | 2-138 |
| Table 2-58 Percent survival, injury and scale loss by species, number assessed, and spraywash pressure.....                                                                                                                                                   | 2-139 |
| Table 2-59 Mean, minimum, and maximum total length (mm), and total number of fish tested at low (1.0, 1.5, and 2.0 ft/s) and high (3.0, 3.5, and 4.0 ft/s) approach velocities. ....                                                                          | 2-140 |
| Table 2-60 Fathead minnow larval numbers collected and total survival for each velocity tested and the controls.....                                                                                                                                          | 2-143 |
| Table 2-61 Fathead minnow egg numbers collected, total survival including and excluding dead larvae for each velocity tested and the controls.....                                                                                                            | 2-145 |
| Table 2-62 White perch larval numbers collected, total survival and adjusted survival for each velocity tested and the controls.....                                                                                                                          | 2-147 |
| Table 2-63 Species, lengths, and number measured of those fish used in Phase I testing...2-150                                                                                                                                                                |       |
| Table 2-64 Mean (with standard deviation), minimum, and maximum fish fork length (mm), and total number of treatment and control fish measured. ....                                                                                                          | 2-154 |
| Table 2-65 Mean (with standard deviation), minimum, and maximum fish fork length (mm), and total number of treatment and control fish measured. ....                                                                                                          | 2-154 |
| Table 3-1 Mean density and mean biomass of selected species impinged at Brunswick, 1977-1985 (from Thompson 2000). ....                                                                                                                                       | 3-3   |
| Table 5-1 Mean densities (numbers/1,000 m <sup>3</sup> of water) of bay anchovies and naked gobies collected in the bongo net from the canal, through each wedgewire exclusion screen, and through an open port in 1982 and 1983 (Weisberg et al. 1987). .... | 5-9   |
| Table 5-2 Density (no./m <sup>3</sup> ) length (mm), and width (mm) of Mysidacea (opossum shrimp) in entrainment sample sets collected January 3, 1979 (Browne 1979). ....                                                                                    | 5-12  |
| Table 5-3 Density (no./m <sup>3</sup> ) length (mm), and width (mm) of Mysidacea (opossum shrimp) in entrainment sample sets collected January 3, 1979 (Browne 1981). ....                                                                                    | 5-13  |
| Table 5-4 Wedgewire screen design and operation parameters evaluated during the laboratory study (EPRI 2003).....                                                                                                                                             | 5-20  |
| Table 5-5 Impingement occurrence (Hanson et al. 1977).....                                                                                                                                                                                                    | 5-24  |

|                                                                                                                                                                                                                                                                  |      |
|------------------------------------------------------------------------------------------------------------------------------------------------------------------------------------------------------------------------------------------------------------------|------|
| Table 5-6 Mean density and standard deviation (SD) of grubby larvae collected at the Sakkonet River site in ambient, control, and test samples during trials with 0.5 and 1.0 mm screens at slot velocities of 0.15 and 0.30 m/sec (EPRI 2005).....              | 5-30 |
| Table 5-7 Mean density and standard deviation (SD) of sand lance larvae collected at the Sakkonet River site in ambient, control, and test samples during trials with 0.5 and 1.0 mm screens at slot velocities of 0.15 and 0.30 m/sec (EPRI 2005).....          | 5-31 |
| Table 5-8 Mean density and standard deviation (SD) of winter flounder larvae collected at the Sakkonet River site in ambient, control, and test samples during trials with 0.5 and 1.0 mm screens at slot velocities of 0.15 and 0.30 m/sec (EPRI 2005).....     | 5-32 |
| Table 5-9 Mean density and standard deviation (SD) of larvae (all species) collected at the Sakkonet River site in ambient, control, and test samples during trials with 0.5 and 1.0 mm screens at slot velocities of 0.15 and 0.30 m/sec (EPRI 2005).....       | 5-33 |
| Table 5-10 Mean density and standard deviation (SD) of eggs collected at the Sakonnet River site in ambient, control, and test samples during trials with 0.5 and 1.0 mm screens at slot velocities of 0.15 and 0.30 m/sec (EPRI 2005). .....                    | 5-34 |
| Table 5-11 Mean density and standard deviation (SD) of carp spp. larvae collected at the Portage River site in ambient, control, and test samples during trials with 0.5 and 1.0 mm screens at slot velocities of 0.15 and 0.30 m/sec (EPRI 2005).....           | 5-34 |
| Table 5-12 Mean density and standard deviation (SD) of freshwater drum larvae collected at the Portage River site in ambient, control, and test samples during trials with 0.5 and 1.0 mm screens at slot velocities of 0.15 and 0.30 m/sec (EPRI 2005).....     | 5-35 |
| Table 5-13 Mean density and standard deviation (SD) of shad larvae collected at the Portage River site in ambient, control, and test samples during trials with 0.5 and 1.0 mm screens at slot velocities of 0.15 and 0.30 m/sec (EPRI 2005).....                | 5-36 |
| Table 5-14 Mean density and standard deviation (SD) of temperate bass larvae collected at the Portage River site in ambient, control, and test samples during trials with 0.5 and 1.0 mm screens at slot velocities of 0.15 and 0.30 m/sec (EPRI 2005).....      | 5-37 |
| Table 5-15 Mean density and standard deviation (SD) of eggs collected at the Portage River site in ambient, control, and test samples during trials with 0.5 and 1.0 mm screens at slot velocities of 0.15 and 0.30 m/sec (EPRI 2005).....                       | 5-37 |
| Table 5-16 Mean density and standard deviation (SD) of naked goby larvae collected at the Chesapeake Bay site in ambient, control, and test samples during trials with 0.5 and 1.0 mm screens at slot velocities of 0.15 and 0.30 m/sec (EPRI 2006b).....        | 5-40 |
| Table 5-17 Mean density and standard deviation (SD) of bay anchovy larvae collected at the Chesapeake Bay site in ambient, control, and test samples during trials with 0.5 and 1.0 mm screens at slot velocities of 0.15 and 0.30 m/sec (EPRI 2006b). .....     | 5-41 |
| Table 5-18 Mean density and standard deviation (SD) of skillettfish larvae collected at the Chesapeake Bay site in ambient, control, and test samples during trials with 0.5 and 1.0 mm screens at slot velocities of 0.15 and 0.30 m/sec (EPRI 2006b).....      | 5-42 |
| Table 5-19 Mean density and standard deviation (SD) of striped blenny larvae collected at the Chesapeake Bay site in ambient, control, and test samples during trials with 0.5 and 1.0 mm screens at slot velocities of 0.15 and 0.30 m/sec (EPRI 2006b).....    | 5-43 |
| Table 5-20 Mean density and standard deviation (SD) of Northern pipefish larvae collected at the Chesapeake Bay site in ambient, control, and test samples during trials with 0.5 and 1.0 mm screens at slot velocities of 0.15 and 0.30 m/sec (EPRI 2006b)..... | 5-44 |
| Table 5-21 Summary of numbers of larvae collected through open pipe and wedgewire screen unit and estimates of average reduction in entrainment densities due to wedgewire screen unit, in comparison to open pipe. ....                                         | 5-48 |



|                                                                                                                                                                                                                                                                                                  |      |
|--------------------------------------------------------------------------------------------------------------------------------------------------------------------------------------------------------------------------------------------------------------------------------------------------|------|
| Table 5-22 Summary of numbers of larvae collected through open pipe and wedgewire screen unit and estimates of average reduction in entrainment densities due to wedgewire screen unit, in comparison to open pipe. ....                                                                         | 5-50 |
| Table 5-23 Relative catches of larvae (Otto et al. 1981).....                                                                                                                                                                                                                                    | 5-52 |
| Table 5-24 Numbers of larval fishes and fish eggs during entrainment and source water sampling at Marin Municipal Water District Desalination (MMWD) pilot plant .....                                                                                                                           | 5-54 |
| Table 6-1 Existing barrier net installations, power plants/diversion field tests .....                                                                                                                                                                                                           | 6-2  |
| Table 6-2 Existing barrier net installations, hydroelectric/diversion field tests .....                                                                                                                                                                                                          | 6-4  |
| Table 6-3 Number of dead fish collected and prevent of fish collected considered too large to pass through the mesh during pre- and post-net installation .....                                                                                                                                  | 6-26 |
| Table 9-1 Species specific results of the Sioux fish return system 24-hr pumping and 24-hr holding tests, March through December, 1981 (Union Electric Company 1982). ....                                                                                                                       | 9-4  |
| Table 9-2 Sioux fish return system 24-hour pumping and 24-hr holding tests, March through December, 1981 (Union Electric Company 1982). ....                                                                                                                                                     | 9-6  |
| Table 9-3 Survival for juvenile Chinook salmon in test groups used to compare Archimedes-1 and Archimedes-2 lifts on the Sacramento River at Red Bluff, CA (McNabb et al. 2003). ....                                                                                                            | 9-13 |
| Table 9-4 Survival of juvenile Chinook salmon in test groups used to compare the Archimedes lifts and Hidrostal pump (McNabb et al. 2003).....                                                                                                                                                   | 9-13 |
| Table 9-5 Mean percent survival (S) and total numbers of fish collected from holding tanks (C) for juvenile Chinook salmon and the four other most common fish species that were entrained from the Sacramento River during 24-hr trials (N = 24) (McNabb et al. 2003) .....                     | 9-14 |
| Table 9-6 Estimates of overall treatment effects for juvenile Chinook salmon passed through the Archimedes lifts and Hidrostal pump (Weber et al. 2002).....                                                                                                                                     | 9-17 |
| Table 9-7 Mean recovery and immediate and 96 hour survival of splittail passed through the Hidrostal pump (treatment fish) compared with those of control fish (Helfrich et al. 2001).....                                                                                                       | 9-19 |
| Table 9-8 Mean recovery and immediate and 96 hour survival of Chinook salmon passed through the Hidrostal pump (treatment fish) compared with those of control fish (Helfrich et al. 2001). ....                                                                                                 | 9-19 |
| Table 9-9 Descaling and injury for quality control (handling), control (no pump passage), and treatment (pump passage) groups of splittail (Helfrich et al. 2001). ....                                                                                                                          | 9-20 |
| Table 9-10 Descaling and injury for quality control (handling), control (no pump passage), and treatment (pump passage) groups of Chinook salmon (Helfrich et al. 2001).....                                                                                                                     | 9-21 |
| Table 9-11 Monthly number, total length range, and survival rate of native and nonnative fish entrained and passed through the helical pump at the Tracy fish collection facility (Helfrich et al. 2001).....                                                                                    | 9-22 |
| Table 9-12 Trial conditions tested. Reported capacities are site-specific electrical supply limits.....                                                                                                                                                                                          | 9-23 |
| Table 9-13 Death and injury rates. Hydrostal pumps with two impeller/speed configurations: $M_{max}$ , low-pitch impeller, maximum speed; $M_{opt}$ , low-pitch impeller optimal speed; $S_{max}$ , high-pitch impeller, maximum speed; and $S_{opt}$ , high-pitch impeller, optimal speed. .... | 9-24 |
| Table 9-14 Effectiveness of a Hidrostal pump in the live transfer of American eels ( <i>Anguilla rostrata</i> ) (Patrick and Sim 1985).....                                                                                                                                                      | 9-26 |
| Table 9-15 Jet pump test results (ESEERCO 1981b).....                                                                                                                                                                                                                                            | 9-29 |
| Table 9-16 Hidrostal test results from 1978 trials (ESEERCO 1981b).....                                                                                                                                                                                                                          | 9-29 |
| Table 9-17 Hidrostal test results 1979 (ESEERCO 1981b) .....                                                                                                                                                                                                                                     | 9-29 |
| Table 9-18 Hidrostal test results – yellow perch prolarvae (ESEERCO 1981b) .....                                                                                                                                                                                                                 | 9-30 |
| Table 9-19 Jet pump test results – yellow perch postlarvae (ESEERCO 1981b).....                                                                                                                                                                                                                  | 9-30 |

|                                                                                                                                                                                                                                                                                                                                                         |       |
|---------------------------------------------------------------------------------------------------------------------------------------------------------------------------------------------------------------------------------------------------------------------------------------------------------------------------------------------------------|-------|
| Table 10-1 Diversion efficiency of angled screens at Brayton Point (Davis et al. 1988).....                                                                                                                                                                                                                                                             | 10-7  |
| Table 10-2 Mean number (SEs in parenthesis) of bull trout entrained and impinged on various types of screen and the number surviving the experiments. ....                                                                                                                                                                                              | 10-16 |
| Table 10-3 Results of diversion tests for all species (McGroddy et al. 1981) .....                                                                                                                                                                                                                                                                      | 10-18 |
| Table 10-4 Comparison of predicted lengths for diversion and total efficiency between the Redondo Beach study and the ESEERCO study (McGroddy et al. 1981).....                                                                                                                                                                                         | 10-21 |
| Table 10-5 Results of 1979 testing showing predicted efficiencies based on larval lengths (Taft et al. 1981b).....                                                                                                                                                                                                                                      | 10-24 |
| Table 10-6 Physical and biological parameters investigated in each test flume (Taft and Mussalli 1978) .....                                                                                                                                                                                                                                            | 10-27 |
| Table 10-7 Total number of tail contacts (T), total number of body contacts (B), swimming velocity (cm/sec, V), total number of fish entering the bypass (E), and rheotaxis (angle of fish to flow, R) of age-0 splittail exposed to a linear, wedge-wire fish screen. ....                                                                             | 10-32 |
| Table 11-1 Number of fish and the percentage of fish descaled during observations made at the T.W. Sullivan Plant in 1991 and 1992 (Clark and Cramer 1993). ....                                                                                                                                                                                        | 11-6  |
| Table 11-2 Experimental design and number of replicates conducted for each screen type, overflow rate (high= 25%, low= 10%), experimental group (three control and two treatment groups), and nominal fish size-classes used to test survival and exclusion of fathead minnow by high-velocity inclined profile-bar screens (Bestgen et al. 2004). .... | 11-10 |
| Table 11-3 ANOVA results for models that assessed the effects of screen type, fish release position, and screen by release position interaction on exclusion and survival rates of various sizes of fathead minnow in tests of high-velocity, inclined, profile-bar screens (Bestgen et al. 2004). ....                                                 | 11-11 |
| Table 11-4 Mean exclusion and survival rates (% SE and number of replicates in parentheses) of 12.5-, 7.5-, and 5.0-mm TL fathead minnow released over four different high-velocity inclined profile-bar screen configurations. ....                                                                                                                    | 11-12 |
| Table 12-1 Fish length data (mm) for species tested with angled bar racks and louvers. ....                                                                                                                                                                                                                                                             | 12-15 |
| Table 12-2 Summary of guidance efficiencies for bar rack and louver tests. ....                                                                                                                                                                                                                                                                         | 12-17 |
| Table 12-3 Summary of results from age-1 lake sturgeon tests with bar racks and louvers angled 15 degrees to the approach flow. ....                                                                                                                                                                                                                    | 12-19 |
| Table 12-4 Summary of results from shortnose sturgeon tests with bar racks and louvers angled 15 degrees to the approach flow. ....                                                                                                                                                                                                                     | 12-20 |
| Table 12-5 Summary of results from American eel guidance trials with bar racks and louvers angled 45 degrees to the approach flow (Amaral et al. 2003). ....                                                                                                                                                                                            | 12-21 |
| Table 12-6 Summary of results from American eel guidance trials with bar racks and louvers angled 15 degrees to the approach flow. ....                                                                                                                                                                                                                 | 12-22 |
| Table 13-1 Summary of strobe light testing conducted during field, cage, and laboratory studies.....                                                                                                                                                                                                                                                    | 13-4  |
| Table 13-2 Summary of mercury light testing conducted during field, cage, and laboratory studies.....                                                                                                                                                                                                                                                   | 13-11 |
| Table 13-3 Summary of tests conducted with other types of light sources during field, cage, and laboratory studies.....                                                                                                                                                                                                                                 | 13-15 |
| Table 13-4 Strobe light testing results for Spirit Lake and Lake Pend Oreille.....                                                                                                                                                                                                                                                                      | 13-35 |
| Table 13-5 Median swimming speed (v) of experimental fish before and after the strobe light was switched on. ....                                                                                                                                                                                                                                       | 13-45 |
| Table 13-6 Mean swimming speed (v) and standard deviation for experimental fish before and after exposure to light in the different rounds.....                                                                                                                                                                                                         | 13-46 |

|                                                                                                                                                                                          |       |
|------------------------------------------------------------------------------------------------------------------------------------------------------------------------------------------|-------|
| Table 13-7 Number of observations, mean and standard deviation of the fish's turning angle (in degrees) after exposure to light. ....                                                    | 13-46 |
| Table 13-8 Integrated power for various regions of the spectrum emitted by the strobe light. ....                                                                                        | 13-54 |
| Table 14-1 Summary of tests conducted with sound devices during field, cage, and laboratory studies.....                                                                                 | 14-3  |
| Table 14-2 Summary of tests conducted with infrasound devices during field, cage, and laboratory studies.....                                                                            | 14-9  |
| Table 14-3 Number of fish collected by species at the four collection sites.....                                                                                                         | 14-38 |
| Table 15-1 Total number of fish, average number per day and percent of total collected from the four intake bays at Indian Point Unit 1 for three time intervals.....                    | 15-4  |
| Table 15-2 Heysham 2 bubble curtain percent impingement reduction.....                                                                                                                   | 15-7  |
| Table 15-3 Number of replicates at each time period for each operating system (Welton et al. 2002).....                                                                                  | 15-8  |
| Table 15-4 Efficiencies of BAFFs with 95% CL during hours of daylight (0500–2100 hrs) and darkness (2100–0500 hrs) (Welton et al. 2002).....                                             | 15-9  |
| Table 15-5 Estimated efficiencies of the BAFFs over the smolt season during daylight and darkness hours (Welton et al. 2002).....                                                        | 15-10 |
| Table 16-1 Summary of avoidance probabilities (95% confidence limits in parentheses) for species and families with sufficient data for conducting statistical analyses.....              | 16-7  |
| Table 16-2 Common name, scientific name and percent collected of the predominant fish species collected during each evaluation type.....                                                 | 16-11 |
| Table 16-3 Results of the MLE Split-Plot analyses of the transformed (natural log) impingement rates using the SPSS mixed procedure. ....                                                | 16-12 |
| Table 16-4 Treatment effectiveness (i.e. ability to elicit avoidance) ranked from highest (1) to lowest (7) based on avoidance probabilities estimated for the three time intervals..... | 16-17 |
| Table 17-1 Impingement estimates for eggs, yolk-sac larvae (YSL), and post yolk-sac larvae (PYSL) of river herring and white perch (Normandeau 2007).....                                | 17-4  |
| Table 17-2 Survival rates for American shad eggs .....                                                                                                                                   | 17-7  |
| Table 17-3 Survival rates for American shad larvae.....                                                                                                                                  | 17-8  |
| Table 17-4 Survival rates for blueback herring eggs tested with clear and turbid water.....                                                                                              | 17-9  |
| Table 17-5 Survival rates for alewife and blueback herring larvae tested with clear and turbid water. ....                                                                               | 17-11 |



# 1

## INTRODUCTION

This technical update provides a comprehensive review of fish protection technologies for possible application at cooling water intake structures (CWISs), as well as other types of water intakes. The information presented can be used as input into a preliminary evaluation of fish protection technology alternatives for use at a given site to meet the requirements of the U.S. Environmental Protection Agency's (EPA) proposed Clean Water Act (CWA) §316(b) Rule for existing facilities and the final Rule for new facilities as subsequently discussed. This report will be revised appropriately in accordance with a final rule for existing CWIS when that Rule is issued by EPA as final in 2013. The case studies provided in this report demonstrate that the potential biological effectiveness and engineering practicability of a given technology will be site-specific and will be strongly influenced by the species and life stages to be protected, the design and operating characteristics of the plant, and the factors associated with geographic location and waterbody type. In the following discussion, the status of each technology is presented along with comments on important factors that influence the potential for effective application at a given site. For those technologies that have not been fully developed, EPRI identifies the additional information that is needed to better define potential effectiveness.

It should be pointed out that the fact that a technology has not been evaluated to date for potential application at CWISs does not imply that it may not be effective. Conversely, the fact that a technology has been evaluated extensively does not necessarily serve as proof that the technology is effective. Finally, while research related to fish protection technologies for hydroelectric and irrigation projects has been conducted, in large part, independently from that for steam electric applications, the combined data and knowledge gained from all research should be used in evaluating the potential application of a given technology at a selected site.

### Section 316(b) of the Clean Water Act

In 1972, Congress passed the CWA and §316(b) of the CWA applied directly to regulating the impacts of CWIS on aquatic life. Specifically, §316(b) requires EPA to ensure that *“the location, design, construction and capacity of cooling water intake structures shall reflect the best technology available for minimizing adverse environmental impact”* (EPA 1972, 2002). EPA issued a Rule in 1977 to implement the CWA §316(b) requirements. However, because of a legal challenge, the regulation was remanded. EPA took no follow-up action to correct the issues raised by the litigation. Permitting authorities subsequently issued §316(b) permits in inconsistent ways including following the guidance provided by EPA or using best professional judgment (BPJ). In 1994, a coalition of environmental groups sued EPA over failure to promulgate national standards enforcing CWA §316(b) requirements. As a result, EPA entered into a consent decree to develop, in phases, final regulations for both existing and new facilities that use CWIS. A Phase I Rule for new facilities was issued in 2001 (EPA 2001). The Phase I Rule essentially requires closed-cycle cooling systems or comparable performing intake technologies as best technology available (BTA) to minimize adverse environmental impact. In 2004, EPA promulgated a Phase II Rule (EPA 2004) to implement regulations for existing power plants that withdraw > 50 million gallons per day (MGD) of cooling water and later a Phase III

Rule for existing power plants withdrawing < 50 MGD and all other industrial facilities that use cooling water. Phase II and III were subsequently challenged and later remanded for revision.

On April 20, 2011, EPA proposed a revised §316(b) Rule for existing power plants and other industrial facilities using cooling water (a combined Phase II and III regulatory action) (EPA 2011). Performance standards and monitoring requirements were proposed for reducing impingement and entrainment mortality. The proposed rule defines impingeable sized organisms as those that will be collected on a 3/8 inch screen while entrainable organisms are those which will pass through a 3/8 inch screen. Relative to impingement, for existing facilities with withdrawals greater than 2 MGD, two compliance alternatives were provided to reduce impingement mortality. The first was direct biological monitoring to demonstrate that impingement mortality was no more than 12% annually and 31% monthly and the second was to demonstrate the through-screen velocity did not exceed 0.5 ft/sec. EPA based these values on analysis of post-impingement survival data from facilities with modified traveling screens and fish return systems and from fish swim speed data, respectively. Relative to entrainment, the compliance standard would be determined by the permitting authority on a “case-by-case” basis. To support this determination, facilities withdrawing more than 125 MGD actual intake flow must submit a number of studies that characterize the presence of early life stages in the source water that are susceptible to entrainment, the extent of entrainment mortality caused by the plant, and an evaluation of entrainment reduction options as well as their environmental impacts and benefits. At a minimum, facilities are required to evaluate use of closed-cycle cooling and fine-mesh screens.

On June 11, 2012, EPA published a Notice of Data Availability Relating to Impingement Control Requirements (NODA) (EPA 2012) and requested comment on a number of issues. EPA proposed potential modifications to the two compliance alternatives and provided a discussion of four additional compliance alternatives that were being considered. These six alternatives include:

- Alternative 1 – The Proposed Rule required installation of modified traveling screens and meeting impingement mortality standards of no more than 12% annually and 31% monthly, verified by biological monitoring. Additionally, impingement of shellfish (crustaceans such as shrimp, crabs, or lobsters) must be reduced to the level achieved by a properly maintained barrier net or other exclusion device. The NODA added that this approach may include taking credit for new or existing fish protection technologies or modifications using a calculation baseline approach to meet the performance standards and that the EPA may revise the numeric criteria. The NODA also indicated that the shellfish technology requirement might be dropped but that shellfish might need to meet the impingement mortality reduction requirement.
- Alternative 2 – The Proposed Rule required facilities to demonstrate the maximum through-screen intake velocity does not exceed 0.5 ft/s under all flow conditions. In the NODA, the EPA indicated potential flexibility relative to meeting the velocity criterion under all flow conditions, potential relief from the proposed Rule requirement for no more than 15% screen blockage, fish entrapment, and proposed a methodology for measuring compliance.
- Alternative 3 – Consideration of a “site-specific” approach in which the determination for the impingement reduction BTA would be made in much the same manner as the BPJ

determination for entrainment. This alternative may be available either generally or based on a demonstration that other alternatives are not feasible.

- Alternative 4 – Consideration of a “streamlined” or pre-approved approach in which modified traveling water screens would be installed, followed by a two-year “optimization study” with no requirement to perform direct biological compliance monitoring.
- Alternative 5 – Consideration for use of a “defined” technology that would potentially include offshore velocity caps and/or closed-cycle recirculating systems. Facilities that employed these technologies would only have to demonstrate they are in place to be in compliance.
- Alternative 6 – Consideration of an exemption for facilities with “low levels of impingement”

Additionally, under either Compliance Alternative 1 or 2, if there is potential for entrapment of fish or shellfish passage must be provided for their return to the source waterbody or existing traveling water screens must be modified with the fish protection features of Compliance Alternative 1. In the NODA, the EPA requested information or data for examples of where addressing entrapment might not be feasible, suggesting it may modify this requirement. The §316(b) Final Rule is scheduled to be issued on or before June 27, 2013.

## **Purpose of Technology Review**

A thorough understanding of fish protection technologies that have potential for application at CWISs is needed to adequately understand the potential technological options available to power generating companies to reduce impingement and entrainment losses at power plant intakes. EPRI has prepared this technical update as a means to disseminate information on the evaluation and application of existing and emerging fish protection technologies. The main objectives of this project were to: (1) gather all available information on permanent installations of fish protection technologies and related research efforts; (2) assess the current status of each technology; and (3) provide summaries of study methods and results for guidance in future technology evaluations. The focus of these efforts was on the identification and evaluation of fish protection technologies installed at CWISs. However, many studies have been conducted at other types of water intakes or have evaluated technologies in controlled experiments or field trials. Therefore, a considerable amount of the information presented in this report describes such research.

## **Approach and Report Organization**

EPRI conducted a comprehensive literature search to gather available information on technology evaluations and to obtain updated information on older evaluations. EPRI reviewed the information obtained for relevance to the report’s objectives. EPRI summarized relevant publications (e.g., journal articles, industry and agency reports, conference papers) describing the evaluations and effectiveness results. EPRI presents site descriptions, study equipment and methods, and effectiveness results for each study reviewed. Within the discussions of each technology, EPRI presents past experience in the following order: (1) full-scale applications at CWISs, (2) other full-scale applications (e.g., hydroelectric, irrigation), and (3) pilot and

laboratory studies. Based on study results, EPRI provides a summary of the technology status. The information EPRI provides in this report, while extensive, might not represent all of the available information on a given technology. Some studies may not have been found during the literature search or may not be publically available. Further, EPRI limits the results of each study, and the conclusions drawn from them, to the objectives of that study. Therefore, relevant questions that might be raised concerning a given technology or its effectiveness may not have been addressed in some studies.

Fish protection technologies can be grouped into four categories based on their mode of action (i.e., means by which they provide fish protection). These groups include physical barriers, collection and return systems, diversion systems, and behavioral guidance devices. The technologies that are included in each of these groups and their mode of action are listed in Table 1-1. In some cases, slight modifications to an existing technology can alter its mode of action. For example, a traveling water screen mounted perpendicular to the approach flow can act as a physical barrier or collection system, if equipped with fish lifting buckets and fish return line. If the screens are mounted at an angle to the approach flow (to guide fish to a bypass), then the screens act as a diversion system. Because a technology can have more than one mode of action, the discussions of technologies within this report have not been grouped by mode of action.



**Table 1-1**  
**Category groupings for fish protection technologies based on mode of action**

| <b>Technology Category</b>                          | <b>Mode of Action</b>                                                                      | <b>System/Technology</b>                                                                                                                                                                                             |
|-----------------------------------------------------|--------------------------------------------------------------------------------------------|----------------------------------------------------------------------------------------------------------------------------------------------------------------------------------------------------------------------|
| Physical Barriers                                   | Physically block fish passage (usually in combination with low water velocity)             | Traveling screens<br>Stationary screens<br>Drum screens<br>Cylindrical wedge wire screens<br>Barrier nets<br>Aquatic filter barrier<br>Porous dikes<br>Radial wells<br>Artificial filter beds<br>Rotary disk screens |
| Collection Systems                                  | Actively or passively collect fish for transport through a return system                   | Modified traveling screens<br>Fish pumps                                                                                                                                                                             |
| Diversion Systems                                   | Divert fish to a return system or safe area                                                | Angled screens<br>Modular Inclined Screen<br>Eicher Screen<br>Angled rotary drum screens<br>Louvers<br>Inclined plane screens<br>Vertical/horizontal traveling screens                                               |
| Behavioral Guidance Technologies (impingement only) | Alter or take advantage of natural behavior patterns to repel or attract fish              | Strobe light<br>Mercury light<br>Other light sources<br>Acoustic systems<br>Infrasound<br>Air bubble curtains<br>Hybrid systems<br>Other behavioral technologies                                                     |
| Flow Reduction                                      | Reduces the amount of flow and number of fish entering the CWIS. Will also reduce velocity | Variable speed pumps<br>Reduced pump operation<br>Closed-cycle cooling (Cooling Towers)                                                                                                                              |

In this report, EPRI presents all available information on fish protection technologies in detail. Emphasis is placed on information that is most applicable to CWISs, but studies at hydroelectric, irrigation, and other water intakes are also presented. Regarding CWIS applications, the information presented does not presume that a technology is actually a part of, or a backfit to, the CWIS. At many sites, protection technologies might be installed at a location remote from the CWIS. For example, a barrier net or behavioral device placed at the entrance to a canal leading to a CWIS can be an effective fish protection technology without being an intake structure technology per se. Site-specific design and operational considerations will determine the best location for the installation of a given technology. This report provides the input necessary to make such determinations.

In this report, EPRI has included a section that allows users to find references to fish protection technologies based on the species evaluated. This table will aid users in finding the relevant

information for species of concern at a given facility. This section has not been updated to reflect additional materials added to the technology document from its previous version; however, following release of the final EPA §316(b) Rule for existing facilities, the table will be updated accordingly.

### **Future Direction**

This technology manual is a work-in-progress and additional information will be added in 2013 when a final EPA §316(b) Rule for existing facilities is issued. Increasingly, fish protection at water intakes is becoming a global concern, especially in Western Europe and the U.K. This manual will be expanded in 2013 to include more international information. In addition, data on on-going fish protection projects continue to become available, and the 2013 Technical Report will include addition material identified since this report was issued.

# 2

## TRAVELING WATER SCREENS

### Introduction

This chapter discusses traditional traveling water screens, as well as screens that have been modified to increase fish survival. Conventional traveling water screens have been modified to improve survival of impinged fish during the duration of their impingement on and spraywash removal from the screens. The first modifications to traveling screens to protect fish were made at Virginia Electric Power (VEP)'s Surry Station in 1976. The Ristroph screens, named for the engineer that designed them, had a screen basket equipped with a water-filled lifting bucket to hold collected organisms as they were carried upward with the rotation of the screen (White and Brehmer 1977). Modified screens typically operate continuously to minimize impingement time. As each bucket passes over the top of the screen, fish are rinsed into a collection trough by a low-pressure spraywash system. Once collected, the fish are transported back to a safe release location in the source water body. Modified traveling screens have been shown to improve fish survival and have been installed and evaluated at a number of power plants.

The U.S. Environmental Protection Agency (EPA) issued a proposed Rule (FR V76, N76, April 20, 2011) implementing Section 316(b) of the Clean Water Act. One approach for meeting the proposed Rule at cooling water intake structures (CWIS) is to install modified traveling screens and monitor their biological performance. Modified traveling screens require a fish return system to transport collected organisms back to the source waterbody. In the proposed Rule, EPA defined some of the characteristics it believes are necessary for a successful fish return, “[The fish return should have] *sufficient water volume and flow to enable impinged organisms to return to the source water. Return systems should be designed to avoid predation and latent mortality while organisms are in the flume, positioned at an appropriate water depth for high survival of the organisms, located at an appropriate elevation to avoid large drops of the organisms back to the surface water, and sited to avoid repeated impingement of the organisms by the intake structure.*” (FR V76, N76 22201). However, there are limited data available on the biological performance of fish return systems and these systems are difficult to sample in the field. Therefore, the Electric Power Research Institute (EPRI) sponsored a multi-year laboratory study looking at survival through a fish return system at various velocities, drop heights, configurations, and with and without debris. The results of that study are presented in this chapter.

Advances in state-of-the-art Ristroph screen design was developed through extensive laboratory and field experimentation. A series of studies conducted by Fletcher (1990) indicated that undesirable hydraulic conditions within the fish lifting buckets resulted in substantial injury to fish due to repeated buffeting. To eliminate these conditions, a number of alternative bucket configurations were developed to create a sheltered area in which fish could safely reside during screen rotation. After several attempts, a bucket configuration was developed that achieved the desired conditions (ENVIREX 1996). In 1995, Public Service Electric and Gas (PSE&G) performed a biological evaluation of the improved screening system installed at the Salem Generating Station in the Delaware River (Heimbuch 1999, Ronafalvy et al. 2000). The reported

survival rates for this installation are among the highest for any traveling screen system (Heimbuch 1999).

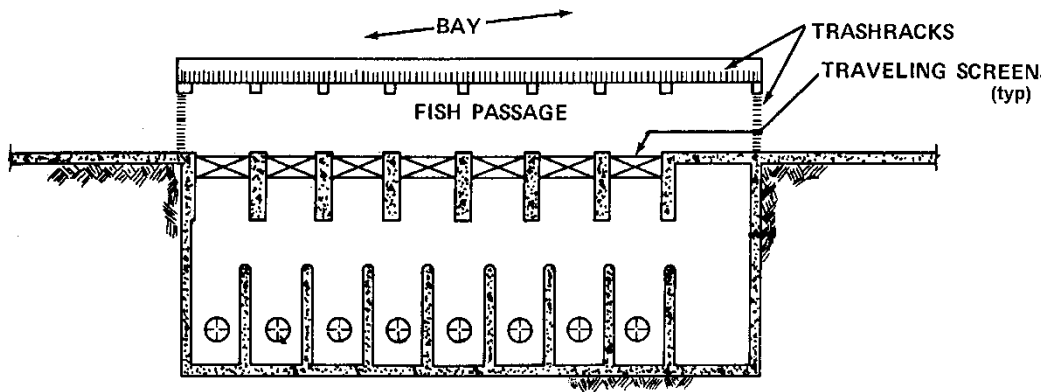
In addition to the fish handling provisions noted above, traveling water screens have been further modified to incorporate screen mesh with openings as small as 0.5 mm (0.02 in.) to collect fish eggs and larvae and return them to the source water body. A number of fine-mesh screen installations have been evaluated for biological effectiveness. Results of these studies indicate that survival is highly species- and lifestage-specific. Species such as bay anchovy (*Anchoa mitchilli*) and *Alosa* spp. have shown low survival while other species, such as striped bass (*Morone saxatilis*), white perch (*Morone americana*), yellow perch (*Perca flavescens*), and invertebrates (crabs and shrimp), show moderate to high survival.

In addition to these field applications, survival data on a variety of species and life stages following impingement on fine-mesh screens is available from extensive laboratory studies. In these studies, larval life stages of striped bass, winter flounder (*Pseudopleuronectes americanus*), alewife (*Alosa pseudoharengus*), yellow perch (*Perca flavescens*), walleye (*Sander vitreus*), channel catfish (*Ictalurus punctatus*), and bluegill (*Lepomis macrochirus*) were impinged on a 0.5 mm (0.02 in.) screen mesh at velocities ranging from 0.2 to 0.9 m/sec (0.5 to 3.0 ft/sec) and for durations of 2, 4, 8 or 16 min. As in the field evaluations, survival was variable between species, larval stages, impingement duration, and velocity (ESEERCO 1981a).

## **Unmodified Traveling Screens**

Traveling screens of various types (e.g., through-flow, dual-flow, and center-flow) are standard features at a CWIS. Typically they are fitted with coarse-mesh (9.5 mm [3/8 in.]) wire mesh. However, without the addition of various fish handling designs (e.g., fish lifting buckets) and operating features (e.g., continuous screen operation), traveling screens generally result in high mortality to all but the hardiest species that become impinged on them. They have no capacity for protecting entrainable-sized organisms. If these screens are placed relatively flush with the face of the CWIS (Figure 2-1) and appropriate hydraulic conditions can be achieved, traveling screens have the capability of offering protection to juvenile and adult fish that have the swimming ability to avoid impingement. Because of these limitations, unmodified traveling screens are unlikely to meet fish protection requirements at most CWIS.

From a biological viewpoint, there is little difference between traveling and stationary screens except where heavy debris clogging makes the traveling screen a better option for maintaining optimal hydraulic conditions.

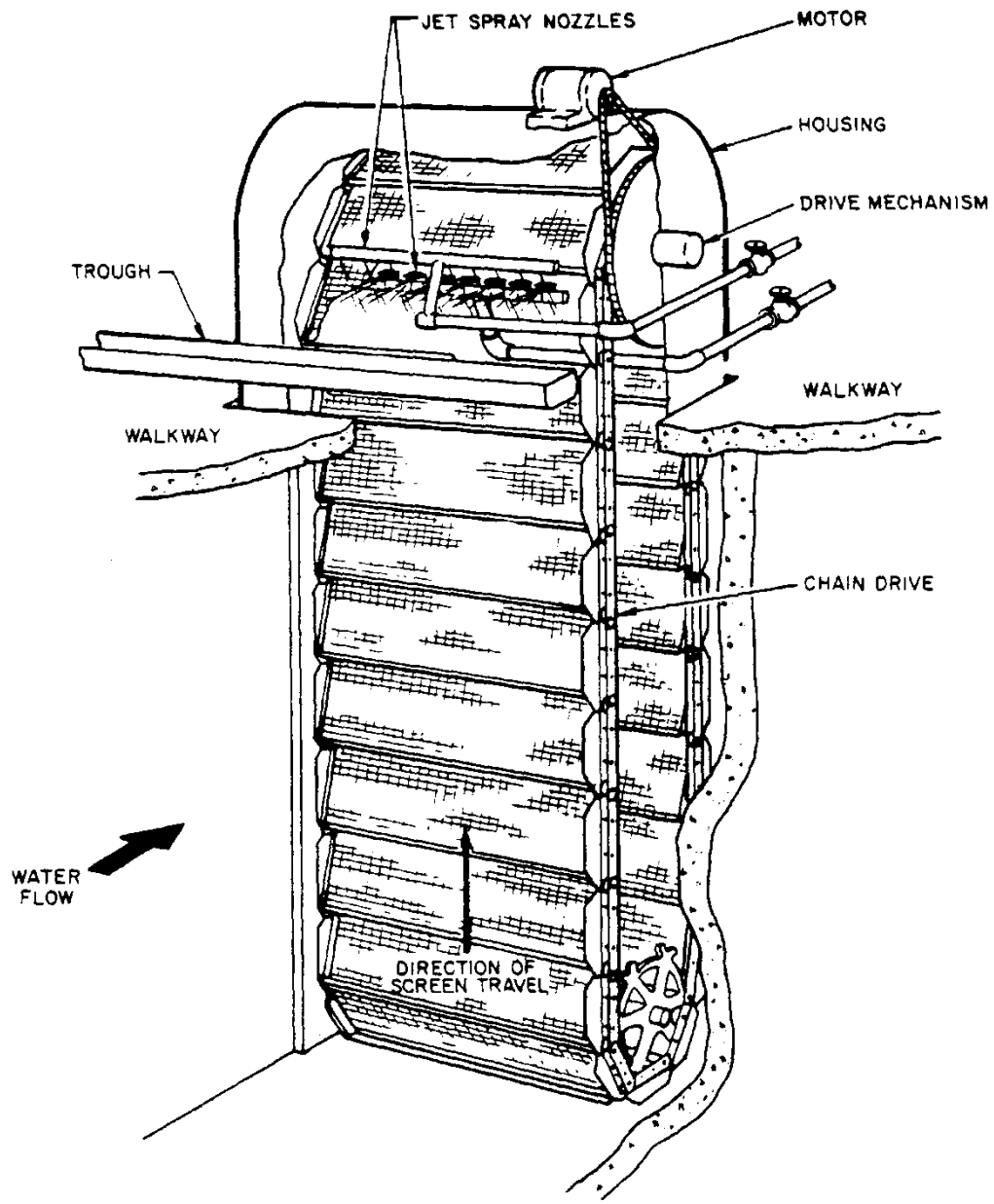


**Figure 2-1**  
**Flush mounted traveling screen (modified from Mussalli et al. 1978)**

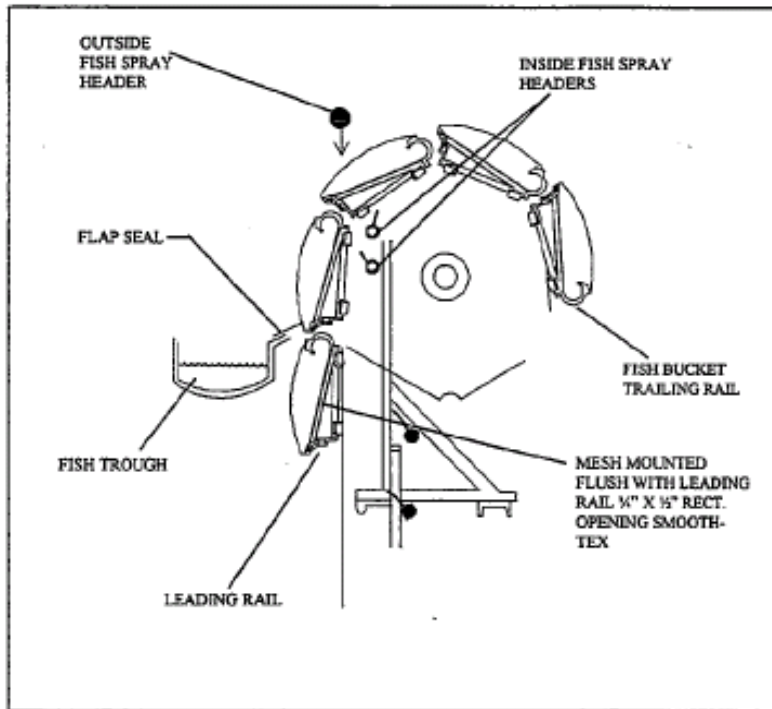
### **Modified Traveling Screens**

Traveling screens are in common use at most steam electric stations. Modifications for fish protection have been incorporated into the design of through-flow, dual-flow, center-flow and no-well screens. In addition, fine-mesh has been incorporated at some sites (and studied for others) as a means to protect fish eggs, larvae, and macroinvertebrates. The U.S. Environmental Protection Agency (EPA) issued a proposed Rule (FR V76, N76, April 20, 2011) implementing Section 316(b) of the Clean Water Act. One approach for meeting the proposed Rule at cooling water intake structures (CWIS) is to install modified traveling screens and monitor their biological performance.

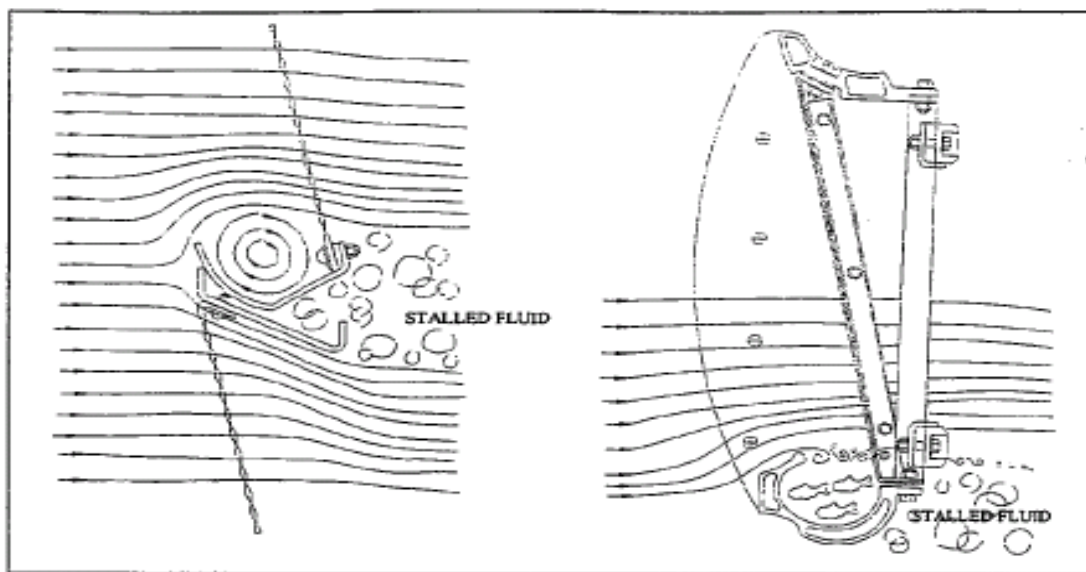
The most common type of traveling screen in use in the U.S. is the through-flow design (Figure 2-2). This screen uses the ascending screen face to collect debris. Debris is removed via a high-pressure spraywash system from either the front (ascending) or back (descending) side of the screen. Such screens have been modified to incorporate new design features that improve the survival potential of impinged organisms. Screens modified in this manner are commonly called "Ristroph Screens" (Figure 2-3 and Figure 2-4).



**Figure 2-2**  
**Schematic of a conventional traveling water screen**



**Figure 2-3**  
Section of a traveling water screen modified for fish protection (Ronafalvy et al. 2000)



**Figure 2-4**  
Section of an old fish basket design (left) and a new fish basket design (right) illustrating the flow field created by each (Ronafalvy et al. 2000)

Each screen basket is equipped with a water-filled lifting bucket that safely contains collected fish as they are carried upward with the rotation of the screen. The screens operate continuously to minimize impingement duration. When each bucket passes over the top of the screen, fish are

gently rinsed into a collection trough by a low-pressure spraywash system. Once collected, the fish are transported back to a safe release location.

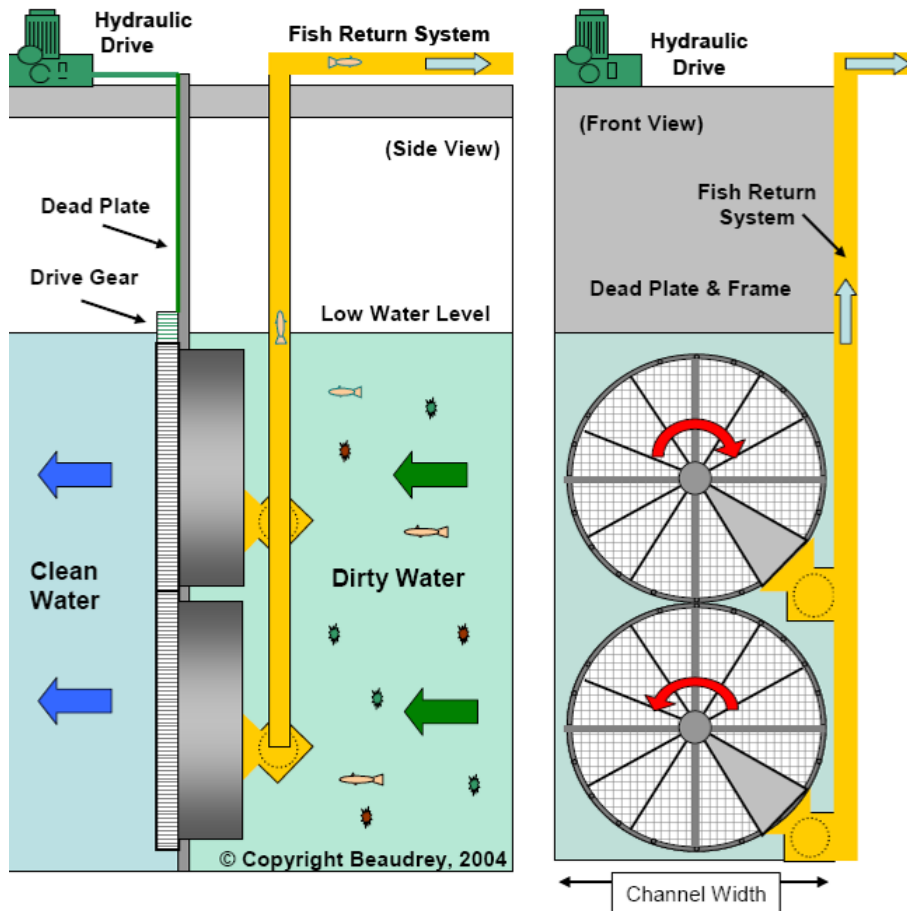
There are other modified screen types that are being tested for use in protecting aquatic organisms. One such screen is the Geiger Multi-Disc™ Screening System. These screens have a through-screen flow pattern with raw water flowing directly through the mesh panels without change in flow direction. In a traditional modified traveling screen, only the ascending side of the screen screens the raw water. By contrast, multi-disc screens' total submerged screening area (the descending and ascending mesh panels as well as mesh panels in the lower guiding section) screens raw water. Fish and debris are retained on the mesh panels and carried upwards in a bucket as the screen band travels through the water column to the discharge position above deck. Debris and fish are washed off the screen above deck level by spraywash headers into a collecting/transfer trough. A low-pressure wash is used to clear the ascending panels, and a high-pressure spraywash is used as the panels descend. As both the ascending and descending sides of the screen are on the same plane (the upstream side) of the system, carryover is eliminated. Mesh size and material (e.g. woven mesh or perforated plate) and screen rotation speed can be designed for site-specific needs. This technology has been successfully applied at one power plant in the US and is currently being tested with the addition of fish protection buckets at other U.S. facilities.

A second screen system being tested in the U.S. is the Hydrolox™ screen. Hydrolox has developed a polymer-based traveling screen with fish handling capabilities. This screen operates similar to conventional traveling screens with a few significant differences. The screen material and the sprockets are made of a lightweight polymer, which results in lighter weight screen compared to standard traveling water screens. The top sprocket of the screen is offset from the bottom sprocket allowing gravity to assist in debris removal, which results in improved debris removal. Hydrolox screens use a single debris/fish return, which reduces the installation and operating costs associated with plumbing and operating a second set of spray headers and running a second return line. Recent laboratory testing of Hydrolox screens has shown that impingement survival rates for several freshwater species are comparable to those observed in laboratory tests using more traditional modified traveling screens. The impingement survival rates of the Hydrolox screen were high enough to meet the IM performance standard for the species tested. To date, Hydrolox screens have been installed at one power plant on the lower Mississippi River (without fish handling modifications). A second Hydrolox screen has been installed at an Atlantic coast facility and its biological efficacy is currently being evaluated (Fall and Winter 2007/08).

The Beaudrey Water Intake Protection (WIP) screen is the most recent variation of a traveling water screen (Figure 2-5). As with the other recently introduced collection systems, the WIP screen has several features that are improvements over more conventional screens. These screens incorporate large, filter disks that are divided into several pie-shaped wedges that rotate on a center axle. Each disk rotates perpendicular to the net intake flow, eliminating any potential for debris carryover. As the disk rotates, each "wedge" passes under a stationary suction scoop mounted over one section of the filter disk. Fish and debris impinged on the screen are vacuumed off as the screen rotates under this section. A fish-friendly pump, one which is designed to handle fragile materials, is used to transport impinged organisms and debris to a return trough. Organisms removed from the screen are continuously submerged, which may reduce or eliminate some of the stresses (e.g., air exposure) associated with handling and return to the waterbody.



The WIP screen has been successfully tested at Omaha Public Power's North Omaha Station, Omaha, Nebraska.



**Figure 2-5**  
**Schematic of a Beaudrey WIP screen (Source: Beaudrey)**

Survival is highly species and lifestage dependent. Therefore, to determine the potential biological effectiveness at a given site, the available data presented in this report should be reviewed relative to the representative important species to be protected. With fine-mesh collection screens, the survival of each species/life stage to be protected must be weighed against the survival that would result if that organism were allowed to pass through coarse-mesh screens and the circulating water system. For some species/life stages, impingement on fine-mesh screens can result in higher mortality than if the organism were allowed to be entrained through the circulating water system. Therefore, for these species/life stages, impacts may actually increase if fine-mesh screens are used to replace, or used instead of, coarse-mesh screens. Information on coarse- and fine-mesh modified traveling screens installations and studies is presented in Table 2-1.

**Table 2-1**  
**Summary of information on modified coarse and fine-mesh traveling screen installations and studies**

| Plant, Location                   | Operator (at Time of Reference Publication) | Mesh Size                          | Screened Flow; Water Source and Debris Type                                           | Screen Type                            | Predominant Species                                                                                           | Reference                            |
|-----------------------------------|---------------------------------------------|------------------------------------|---------------------------------------------------------------------------------------|----------------------------------------|---------------------------------------------------------------------------------------------------------------|--------------------------------------|
| Salem Station, Delaware River     | Public Service Electric & Gas Company       | 6.4 mm by 12.7 mm rectangular mesh | 140 m <sup>3</sup> /sec; brackish water with heavy debris loading                     | Through-flow with lateral fish passage | weakfish                                                                                                      | Ronafalvy et al. 2000; Heimbuch 1999 |
| Roseton Station, Hudson River     | Central Hudson Electric & Gas Company       | 3.2 mm by 12.7 mm Smooth-tex       | 10.3 m <sup>3</sup> /sec; fresh water with seasonal heavy debris loading              | Dual-flow with lateral fish passage    | blueback herring, alewife, American shad, white perch, bay anchovy, striped bass                              | LMS 1991                             |
| Indian Point Unit 2, Hudson River | Consolidated Edison                         | 9.5 mm                             | 133 m <sup>3</sup> /sec; brackish water with heavy seasonal debris loading            | Through-flow                           | alewife, striped bass, white perch                                                                            | Con. Ed. 1986; Fletcher 1990         |
| Danskammer Point, Hudson River    | Central Hudson Gas & Electric Company       | 9.5 mm                             | Total 4 units: 20 m <sup>3</sup> /sec; fresh water with heavy seasonal debris loading | Through-flow                           | alewife, Atlantic tomcod, white perch, blueback herring, spottail shiner, American shad, gizzard shad         | Ecological Analysts 1982             |
| Surry Station, James River        | Virginia Electric Power Company             | 9.5 mm                             | 111 m <sup>3</sup> /sec; brackish water with moderate debris loading                  | Through-flow                           | American shad, alewife, croaker, menhaden, silversides, bay anchovy, spotted seatrout, silver perch, weakfish | White and Brehmer 1977               |

| Plant, Location                                | Operator<br>(at Time of<br>Reference<br>Publication) | Mesh Size | Screened Flow; Water<br>Source and Debris Type                                        | Screen Type                                  | Predominant Species                                                                                                                                                                | Reference                     |
|------------------------------------------------|------------------------------------------------------|-----------|---------------------------------------------------------------------------------------|----------------------------------------------|------------------------------------------------------------------------------------------------------------------------------------------------------------------------------------|-------------------------------|
| Oyster Creek,<br>Barnegat Bay                  | Jersey<br>Central Power<br>& Light                   | 9.5 mm    | 116 m <sup>3</sup> /sec; marine with<br>heavy seasonal debris<br>loading              | Through-flow                                 | Atlantic silverside,<br>Atlantic menhaden,<br>bay anchovy, blueback<br>herring, Northern<br>pipefish, smallmouth<br>flounder, striped<br>searobin, silver<br>seatrout              | Thomas and<br>Miller 1976     |
| Oswego Station, Lake<br>Ontario                | Niagara<br>Mohawk<br>Power<br>Corporation            | 9.5 mm    | 20.5 m <sup>3</sup> /sec; freshwater<br>with heavy seasonal<br>debris loading         | Angled through-<br>flow                      | rainbow smelt, alewife,<br>white perch, emerald<br>shiner, gizzard shad,<br>spottail shiner                                                                                        | LMS 1984                      |
| Bowline Point Station,<br>Hudson River Estuary | Orange and<br>Rockland<br>Utilities                  | 9.5 mm    | Flow not reported;<br>brackish with seasonal<br>heavy debris loading                  | Through-flow                                 | striped bass, white<br>perch                                                                                                                                                       | King et al. 1978              |
| Belle River Plant, St.<br>Clair River          | Detroit Edison                                       | 9.5 mm    | 41.7 m <sup>3</sup> /sec; freshwater<br>with seasonal ice and<br>heavy debris loading | Through-flow<br>with lateral fish<br>passage | alewife, gizzard shad,<br>mottled sculpin,<br>darters, logperch,<br>white sucker, rock<br>bass, rainbow smelt,<br>emerald shiner,<br>bluntnose minnow                              | Freshwater<br>Physicians 1991 |
| Laboratory Study                               | EPRI / Alden                                         | 9.5 mm    | Not applicable                                                                        | Through-flow                                 | golden shiner, fathead<br>minnow, white sucker,<br>bigmouth buffalo,<br>channel catfish, hybrid<br>striped bass, bluegill,<br>largemouth bass,<br>yellow perch,<br>freshwater drum | EPRI 2006a                    |

| <b>Plant, Location</b>                                   | <b>Operator<br/>(at Time of<br/>Reference<br/>Publication)</b> | <b>Mesh Size</b>            | <b>Screened Flow; Water<br/>Source and Debris Type</b>                           | <b>Screen Type</b> | <b>Predominant Species</b>                                                                            | <b>Reference</b>                   |
|----------------------------------------------------------|----------------------------------------------------------------|-----------------------------|----------------------------------------------------------------------------------|--------------------|-------------------------------------------------------------------------------------------------------|------------------------------------|
| Arthur Kill Generating Station, Arthur Kill Tidal Strait | Consolidated Edison Company of New York                        | 3.2 mm                      | Total flow 28.6 m <sup>3</sup> /sec; brackish with heavy seasonal debris loading | Dual-flow          | Atlantic herring, Atlantic silverside, bay anchovy, blueback herring, Atlantic Menhaden               | ConEd 1996                         |
| Dunkirk Station, Lake Erie                               | Niagara Mohawk Power Company                                   | 3.2 mm                      | 25.2 m <sup>3</sup> /sec freshwater, debris type not reported                    | Dual-flow          | alewife, shiners, rainbow smelt, white bass, white perch, yellow perch, gizzard shad, freshwater drum | Beak Consultants, Inc. 1988, 2000a |
| Huntley Steam Station, Niagara River                     | Niagara Mohawk Power Company                                   | 3.2 mm by 12.7mm Smooth Tex | Flow not reported, freshwater, debris type not reported                          | Through-flow       | alewife, gizzard shad, rainbow smelt, emerald shiner, trout-perch                                     | Beak Consultants, Inc. 2000b       |
| Indian Point Unit 1, Hudson River                        | Consolidated Edison                                            | 2.5 mm                      | 133 m <sup>3</sup> /sec; brackish water with heavy seasonal debris loading       | Through-flow       | striped bass, white perch, Alosa spp., rainbow smelt, Atlantic tomcod, bay anchovy                    | Ecol. Anal. 1977, 1979; TI 1978    |
| Hanford Generating Plant, Columbia River                 | Washington Public Power Supply System                          | 3.2 mm                      | 35.6 m <sup>3</sup> /sec; freshwater                                             | Through-flow       | Chinook salmon, yellow perch                                                                          | Page et al. 1977                   |
| 100-N Generating Plant, Columbia River                   | U.S. D.O.E.                                                    | 3.2 mm                      | 26.4 m <sup>3</sup> /sec; freshwater                                             | Through-flow       | Chinook salmon, yellow perch                                                                          | Page et al. 1977                   |
| Calvert Cliffs, Chesapeake Bay                           | Baltimore Gas & Electric                                       | 10 mm                       | 30.5 m <sup>3</sup> /sec; salt water with light debris loading                   | Dual-flow          | Atlantic menhaden, spot, hogchoker, bay anchovy, Atlantic silverside, Atlantic croaker, white perch   | Ringger 2000; Horwitz 1987         |

| <b>Plant, Location</b>                                | <b>Operator<br/>(at Time of<br/>Reference<br/>Publication)</b> | <b>Mesh Size</b>  | <b>Screened Flow; Water<br/>Source and Debris Type</b>                      | <b>Screen Type</b>     | <b>Predominant Species</b>                                                                                                                         | <b>Reference</b>                            |
|-------------------------------------------------------|----------------------------------------------------------------|-------------------|-----------------------------------------------------------------------------|------------------------|----------------------------------------------------------------------------------------------------------------------------------------------------|---------------------------------------------|
| Mystic Station, Mystic River                          | Boston Edison Company                                          | Smooth-text       | marine with seasonally heavy debris and jellyfish loading                   | Through flow           | rainbow smelt, Alosa spp., winter flounder, Atlantic tomcod                                                                                        | SWEC 1981; Taft et al. 1986                 |
| Big Bend Station, Tampa Bay, FL                       | Tampa Electric Company                                         | 0.5 mm            | 30.5m <sup>3</sup> /sec; salt water with light debris loading               | Dual-flow, No-well     | bay anchovy, black drum, silver perch, spotted seatrout, scaled sardine, tidewater silverside, stone crab, pink shrimp, American oyster, blue crab | Taft et al. 1981a, Bruggemeyer et al. 1988  |
| Prairie Island Station, Mississippi River, MN         | Northern States Power Company                                  | 0.5 mm            | 39.7 m <sup>3</sup> /sec; fresh water with moderate seasonal debris loading | Through-flow           | gizzard shad, carp, shiners, catostomids, channel catfish, white bass, freshwater drum                                                             | Kuhl and Mueller 1988                       |
| Brayton Point Station, Mt. Hope Bay, MA               | New England Power Company                                      | 1.0 mm/<br>9.5 mm | 16.4m <sup>3</sup> /sec; salt water with moderate, seasonal debris loading  | Angled, through-flow   | Atlantic silverside, bay anchovy, tautog, Northern pipefish                                                                                        | LMS 1985                                    |
| Somerset (formerly Kintigh) Station, Lake Ontario, NY | NY State Electric & Gas Company                                | 1.0 mm            | 12.3 m <sup>3</sup> /sec; fresh water with light debris loading             | Through-flow           | alewife, rainbow smelt, shiners, tessellated darter, mottled sculpin                                                                               | NYSEG et al. 1990; McLaren and Tuttle 2000. |
| Brunswick Station, Cape Fear Estuary                  | Carolina Power & Light Company                                 | 1.0 mm            | 17.1 m <sup>3</sup> /sec; salt water with heavy seasonal debris loading     | Through-flow           | croaker, spot, bay anchovy, menhaden, Atlantic silverside, shrimps, crabs                                                                          | Carolina Power & Light 1985a & 1985b        |
| Barney Davis Station, Laguna Madre, TX                | Central Power & Light Company                                  | 0.5 mm            | 21.5 m <sup>3</sup> /sec; salt water with heavy loading of grasses          | Passavant, center-flow | gulf menhaden, bay anchovy, Atlantic croaker, Penaeid shrimp, rainwater killifish                                                                  | Murray and Jinnette 1978                    |

| <b>Plant, Location</b>                          | <b>Operator<br/>(at Time of<br/>Reference<br/>Publication)</b> | <b>Mesh Size</b> | <b>Screened Flow; Water<br/>Source and Debris Type</b>                                  | <b>Screen Type</b> | <b>Predominant Species</b>                                                                                                                    | <b>Reference</b>                 |
|-------------------------------------------------|----------------------------------------------------------------|------------------|-----------------------------------------------------------------------------------------|--------------------|-----------------------------------------------------------------------------------------------------------------------------------------------|----------------------------------|
| Laboratory Study                                | ESEERCO                                                        | 0.5 mm           | Not applicable                                                                          | Through-flow       | striped bass, winter flounder, alewife, yellow perch, walleye, channel catfish and bluegill                                                   | Taft et al. 1981b, ESEERCO 1981a |
| Manchester Street Station, Providence, RI       | Narragansett Electric and New England Power Company            | 9.5 mm           | not reported; Providence River; algae, terrestrial vegetation, invertebrates, and trash | Through-flow       | Atlantic menhaden, winter flounder, Atlantic silverside, white perch, threespine stickleback, Northern pipefish                               | Marine Research 1997             |
| Millstone Unit 3, Waterford, CT                 | Northeast Utilities Service Company                            | 4.8 mm           | 56.6 m3/sec ; Niantic Bay; not reported                                                 | Through-flow       | Atlantic menhaden, Atlantic silverside, bay anchovy, bluefish, butterfish, grubby, Northern pipefish, threespine stickleback, winter flounder | NUSCO 1987                       |
| Scattergood Generating Station, Los Angeles, CA | Los Angeles Department of Water and Power                      | 9.5 mm           |                                                                                         | Through-flow       | queenfish, topsmelt, white croaker, walleye surfperch, jack                                                                                   | Miller 2007                      |
| H. A. Wagner, Baltimore, MD                     | Baltimore Gas and Electric Company                             | 9.5 mm           | not reported; Patapsco River; not reported                                              | Through-flow       | Atlantic menhaden, bay anchovy, hogchoker, Atlantic croaker, silversides                                                                      | Breitburg and Reiher 1988        |
| E. F. Barrett, Island Park, NY                  | National Grid                                                  | 0.64 by 2.5 cm   | 12.9 m3/sec; Hempstead Bay; not reported                                                | Through-flow       | Atlantic silverside, mummichog, Atlantic menhaden, Northern pipefish, seaboard goby                                                           | ASA 2008                         |

| <b>Plant, Location</b>                | <b>Operator<br/>(at Time of<br/>Reference<br/>Publication)</b> | <b>Mesh Size</b>       | <b>Screened Flow; Water<br/>Source and Debris Type</b>   | <b>Screen Type</b> | <b>Predominant Species</b>                                                                                                                           | <b>Reference</b>              |
|---------------------------------------|----------------------------------------------------------------|------------------------|----------------------------------------------------------|--------------------|------------------------------------------------------------------------------------------------------------------------------------------------------|-------------------------------|
| Hudson Generating Station             | Public Service Electric & Gas Company                          | 0.64 by 1.27-cm        | 39.1 m <sup>3</sup> /sec; Hackensack River; not reported | Through-flow       | white perch, bay anchovy, spotted hake, Atlantic silverside, red hake, threespine stickleback                                                        | ASA 2011                      |
| Fort Calhoun Station, Blair, Nebraska | Omaha Public Power District                                    | 9.5 mm                 | 22.7 m <sup>3</sup> /sec; Missouri River; not reported   | Through-flow       | common carp, gizzard shad, freshwater drum, bluegill, channel catfish, rainbow smelt                                                                 | EA 2011                       |
| North Omaha Station, Omaha, Nebraska  | Omaha Public Power District                                    | 6.1 mm                 | 32 m <sup>3</sup> /sec; Missouri River; not reported     | Through-flow       | channel catfish, bluegill, fathead minnow                                                                                                            | EPRI 2009a; Bigbee et al 2010 |
| Laboratory Study                      | EPRI/Alden                                                     | 0.5, 1.0, 1.78, 2.0 mm | Not applicable                                           | Through-flow       | smallmouth bass, emerald shiner, golden shiner, fathead minnow, channel catfish, common carp, blue catfish, white sucker, bigmouth buffalo, bluegill | EPRI 2009b,2010               |
| Laboratory Study                      | EPRI/Alden                                                     | 2.0 mm                 | Not applicable                                           | Through-flow       | common carp, golden shiner, bluegill, alewife                                                                                                        | EPRI 2010a, 2011a             |
| Laboratory Study                      | EPRI/Alden                                                     | 2.0 mm                 | Not applicable                                           | Through-flow       | bigmouth buffalo, white sucker, common carp, bluegill                                                                                                | EPRI 2011b                    |
| Laboratory Study                      | Aquaria/Alden                                                  | 2.0 mm                 | Not applicable                                           | Through-flow       | fathead minnow, white perch, alewife                                                                                                                 | Alden 2012a,b                 |

Efforts to optimize the biological effectiveness of modified screens are continuing and should lead to improved survival for even fragile species. Our understanding of fish/screen interactions, important hydraulic conditions, and the contributions of the various screen system components to injury and mortality have improved over the past 15 years and should continue to be investigated.

## **Case Studies – CWIS Application**

### ***Dunkirk Steam Station***

As part of efforts to improve fish survival at the Dunkirk Steam Station on Lake Erie in New York, dual-flow screens were installed at both units and were evaluated in 1987 (Beak 1988) and in 1990/1991 (Lindsay 1991). The screens incorporate 3.2-mm (1/8-in.) square mesh. In these studies, the screen was operated continuously at 9.1 or 27.4 cm/s (0.3 or 0.9 ft/sec). We present results of the later studies in Table 2-2.

In 1998, a modified dual-flow screen was installed in one bay of Unit 1 for evaluation. The screen appears on Figure 2-6. The new screen incorporates a nose cone on its upstream, solid wall to create improve flow distribution across the screen face. It also incorporates an improved fish bucket design and internal and external low-pressure fish sprays. Preliminary survival data is available for the winter of 1998/99, as we present in Table 2-3 (Beak 2000a). The results show high survival for most species and suggest that the improved screen design may further enhance the fish handling capabilities of this type of collection screen. The results of continued studies in the spring, summer, and fall testing will determine whether improved survival trends will continue with other species in other seasons.

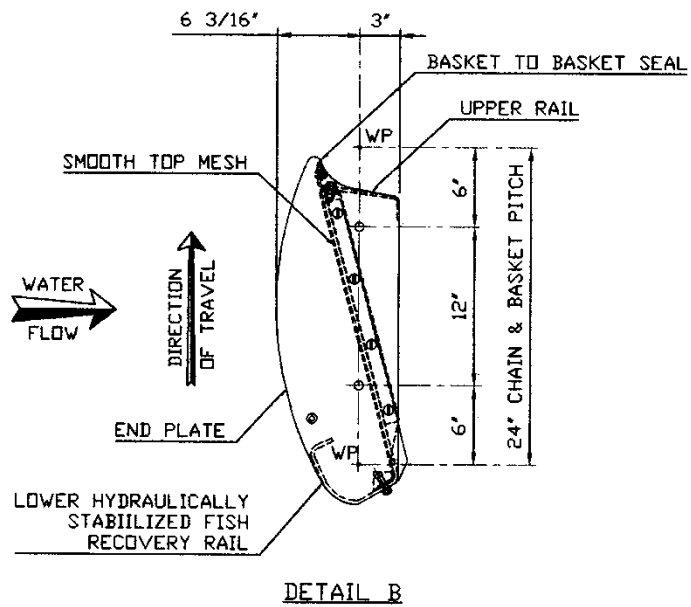
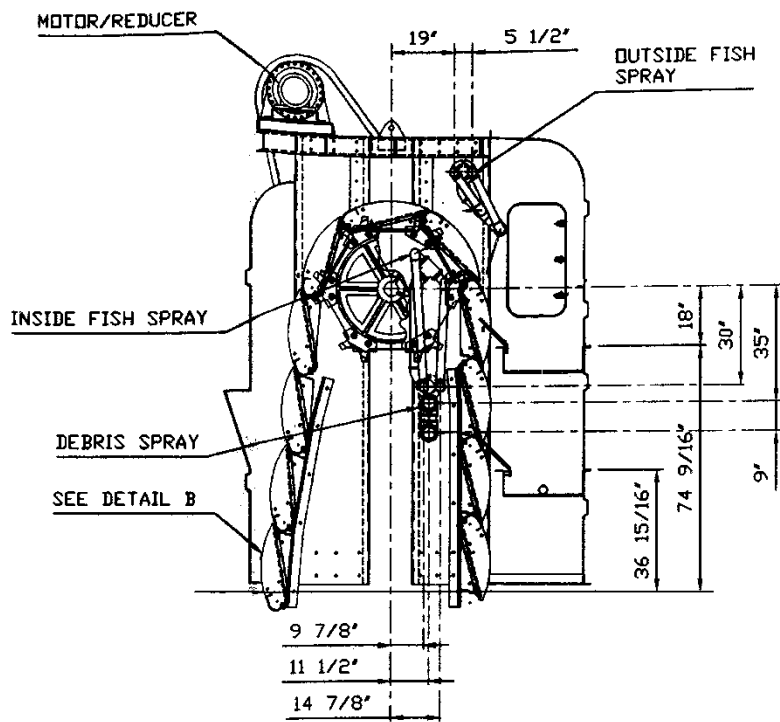


**Table 2-2**  
**Dual-flow screen post-impingement survival study results — Dunkirk Steam Station (August 1990–January 1991) (Lindsay 1991)**

| Species                            | Life Stage | Number Collected | Initial Classification |      |                      | Final Classification |      |                       | Survival (%) |
|------------------------------------|------------|------------------|------------------------|------|----------------------|----------------------|------|-----------------------|--------------|
|                                    |            |                  | Live                   | Dead | Initial Survival (%) | Live                 | Dead | Extended Survival (%) |              |
| alewife                            | juvenile   | 25               | 8                      | 17   | 32.0                 | 2                    | 6    | 25.0                  | 8.0          |
| emerald shiner                     | juvenile   | 3,540            | 2,877                  | 663  | 81.3                 | 1,060                | 228  | 82.3                  | 66.9         |
|                                    | adult      | 251              | 228                    | 23   | 90.8                 | 150                  | 4    | 97.4                  | 88.4         |
| gizzard shad                       | juvenile   | 221              | 156                    | 65   | 70.6                 | 29                   | 98   | 22.8                  | 16.1         |
|                                    | adult      | 1                | 1                      | 0    | 100.0                | 0                    | 1    | 0.0                   | 0.0          |
| rainbow smelt                      | juvenile   | 995              | 547                    | 448  | 55.0                 | 185                  | 263  | 41.3                  | 22.7         |
|                                    | adult      | 1,835            | 1,535                  | 300  | 83.7                 | 204                  | 152  | 57.3                  | 48.0         |
| white bass                         | juvenile   | 6                | 5                      | 1    | 83.3                 | 5                    | 0    | 100.0                 | 83.3         |
|                                    | adult      | 1                | 1                      | 0    | 100.0                | 1                    | 0    | 100.0                 | 100.0        |
| white perch                        | juvenile   | 665              | 516                    | 149  | 77.6                 | 422                  | 94   | 81.8                  | 63.5         |
| yellow perch                       | juvenile   | 16               | 13                     | 3    | 81.3                 | 13                   | 0    | 100.0                 | 81.3         |
| Centrarchidae <sup>1</sup>         | juvenile   | 31               | 28                     | 3    | 90.3                 | 28                   | 0    | 100.0                 | 90.3         |
| spottail shiner                    | juvenile   | 38               | 25                     | 13   | 65.8                 | 17                   | 5    | 77.3                  | 50.8         |
|                                    | adult      | 2                | 2                      | 0    | 100.0                | 2                    | 0    | 100.0                 | 100.0        |
| others<br>(5 species) <sup>2</sup> | juvenile   | 11               | 10                     | 1    | 90.9                 | 10                   | 0    | 100.0                 | 90.9         |
|                                    | adult      | 4                | 4                      | 0    | 100.0                | 1                    | 3    | 25.0                  | 25.0         |

<sup>1</sup> Includes: bluegill (*Lepomis macrochirus*) (19), pumpkinseed (*Lepomis gibbosus*) (1), largemouth bass (*Micropterus salmoides*) (1), rock bass (*Ambloplites rupestris*) (4), white crappie (*Pomoxis annularis*) (4), and unidentified (1).

<sup>2</sup> Includes: logperch (*Percina caprodes*) (1), trout-perch (*Percopsis omiscomaycus*) (4), fathead minnow (*Pimephales promelas*) (1), freshwater drum (*Aplodinotus grunniens*) (3), and mottled sculpin (*Cottus bairdii*) (6).



**Figure 2-6**  
**Modified dual-flow screen at Dunkirk Station (Beak 1988)**

**Table 2-3  
Dunkirk Station early winter survival testing results (Beak 2000a)**

| Species                 | Initial |          |       |              | 24 Hr |          |       |              | Total Tested | Total Survival (%) |
|-------------------------|---------|----------|-------|--------------|-------|----------|-------|--------------|--------------|--------------------|
|                         | Dead    | Stressed | Alive | Survival (%) | Dead  | Stressed | Alive | Survival (%) |              |                    |
| emerald shiner          | 45      | 0        | 3,693 | 98.8         | 23    | 1        | 3,669 | 99.4         | 3,738        | 98.2               |
| gizzard shad "juvenile" | 54      | 0        | 1,873 | 97.2         | 34    | 14       | 1,825 | 97.4         | 1,927        | 94.7               |
| rainbow smelt           | 29      | 0        | 585   | 95.3         | 66    | 8        | 511   | 87.4         | 614          | 83.2               |
| spottail shiner         | 0       | 0        | 297   | 100.0        | 1     | 0        | 296   | 99.7         | 297          | 99.7               |
| gizzard shad "adult"    | 3       | 0        | 90    | 96.8         | 1     | 3        | 86    | 95.6         | 93           | 92.5               |
| yellow perch            | 0       | 0        | 66    | 100.0        | 0     | 0        | 66    | 100.0        | 66           | 100.0              |
| rock bass               | 2       | 0        | 22    | 91.7         | 0     | 0        | 22    | 100.0        | 24           | 91.7               |
| trout-perch             | 3       | 0        | 5     | 62.5         | 0     | 0        | 5     | 100.0        | 8            | 62.5               |
| bluegill                | 0       | 0        | 3     | 100.0        | 0     | 0        | 3     | 100.0        | 3            | 100.0              |
| white bass              | 0       | 0        | 1     | 100.0        | 0     | 0        | 1     | 100.0        | 1            | 100.0              |
| freshwater drum         | 0       | 0        | 1     | 100.0        | 0     | 0        | 1     | 100.0        | 1            | 100.0              |
| shorthead redhorse      | 0       | 0        | 1     | 100.0        | 0     | 0        | 1     | 100.0        | 1            | 100.0              |
| largemouth bass         | 0       | 0        | 1     | 100.0        | 0     | 0        | 1     | 100.0        | 1            | 100.0              |
| sculpin                 | 0       | 0        | 1     | 100.0        | 0     | 0        | 1     | 100.0        | 1            | 100.0              |

A biological evaluation of a prototype dual-flow traveling screen was conducted at Dunkirk Station in 1998–1999, with sampling commencing in the winter of 1998. The goals of this study were to estimate the survival of commonly impinged species, to assess the effects of collection and handling on impinged species, to assess the effectiveness of the low pressure spray wash in the removal of fish from the screens, and to determine ways to optimize post-impingement survival.

The shoreline CWIS at the Dunkirk Steam Station includes a skimmer wall and two screenhouses. Fish collected for this evaluation were taken off a prototype Ristroph dual-flow traveling screen in Screenhouse #1. The screen is 3.35 m (11 ft) wide and 8.84 m (29 ft) deep and is comprised of "smooth tex" stainless steel mesh, 3.2 mm by 12.7 mm (1/8 in. by 1/2 in.) and a fish collection bucket. The screen was run continuously during sampling. Water from the dual fish/debris return trough was diverted for 2 hrs for each sample. Fish were directed to a collection table and then were transferred in water to holding tanks where they were held for the 24-hr latent mortality study. Observations of fish condition were made at 2, 4, 8, and 24 hrs after collection. A total of 32 sampling events were conducted during this year-long study, with eight samples being collected each during the winter, spring, summer, and fall.

The evaluation of the effects of collection and handling on impinged fish was conducted using commercially available golden shiner (*Notemigonus crysoleucas*). Fish used as collection handling controls were introduced to the fish return trough without being subjected to impingement, while fish used as handling controls were simply placed in the latent mortality holding tanks. Results of the handling and holding controls showed survivals of 100 and 98.6% respectively; indicating that very little to no mortality was attributable to the handling or holding of the test fish.

The evaluation of the low pressure spray wash system was conducted with smallmouth bass (*Micropterus dolomieu*) and yellow perch (*Perca flavescens*). Test fish were stained with rose bengal dye, introduced in groups of two to four to the fish buckets on the traveling screen and were collected in wire mesh baskets placed in the fish/debris return trough. Trials were run with six combinations of spray pressures on the inside and outside spray headers. Results of the spray system evaluation indicate that low outside spray pressures of 0–5 psi yielded the best recovery rates (92–100%). Furthermore, nearly all fish not collected in the fish trough were collected in the debris trough.

A total of 20,485 fish were collected for the latent mortality studies. A summary by season of the number of individuals collected, initial and 24-hr extended survival, and total survival of target species is given in Table 2-4.

**Table 2-4  
Dunkirk Station impingement survival testing results for target species 1998–1999 (Beak 2000a)**

| Species                           | Total Tested | Initial Survival (%) | 24-Hr Survival (%) | Total Survival (%) |
|-----------------------------------|--------------|----------------------|--------------------|--------------------|
| Dec 20–23, 1998 and Jan 6–9, 1999 |              |                      |                    |                    |
| emerald shiner                    | 3,738        | 98.8                 | 99.4               | 98.2               |
| gizzard shad juvenile             | 1,927        | 97.2                 | 97.4               | 94.7               |
| rainbow smelt                     | 614          | 95.3                 | 87.4               | 83.2               |
| spottail shiner                   | 297          | 100.0                | 99.7               | 99.7               |
| gizzard shad adult                | 93           | 96.8                 | 95.6               | 92.5               |
| yellow perch                      | 66           | 100.0                | 100.0              | 100.0              |
| white bass                        | 1            | 100.0                | 100.0              | 100.0              |
| freshwater drum                   | 1            | 100.0                | 100.0              | 100.0              |
| April 20–28, 1999                 |              |                      |                    |                    |
| emerald shiner                    | 2,564        | 98.5                 | 96.5               | 95.0               |
| rainbow smelt                     | 318          | 89.3                 | 70.8               | 63.2               |
| alewife                           | 260          | 83.5                 | 35.9               | 30.0               |
| spottail shiner                   | 132          | 99.2                 | 99.2               | 98.5               |
| trout-perch                       | 51           | 100.0                | 94.1               | 94.1               |
| white perch                       | 2            | 100.0                | 100.0              | 100.0              |
| white bass                        | 1            | 100.0                | 100.0              | 100.0              |
| freshwater drum                   | 1            | 0.0                  | 0.0                | 0.0                |
| Aug 16–Sept 4, 1999               |              |                      |                    |                    |
| rainbow smelt                     | 48           | 79.2                 | 23.7               | 18.8               |
| alewife                           | 12           | 25.0                 | 0.0                | 0.0                |
| white bass                        | 6            | 100.0                | 83.3               | 83.3               |
| Nov 2–11, 1999                    |              |                      |                    |                    |
| emerald shiner                    | 6,072        | 98.8                 | 99.1               | 98.0               |
| gizzard shad juvenile             | 1,477        | 99.7                 | 98.9               | 98.6               |
| rainbow smelt                     | 473          | 96.8                 | 78.4               | 75.9               |
| spottail shiner                   | 263          | 98.9                 | 99.6               | 98.5               |
| yellow perch                      | 178          | 98.9                 | 100.0              | 98.9               |
| white bass                        | 147          | 98.6                 | 100.0              | 98.6               |
| white perch                       | 45           | 100.0                | 100.0              | 100.0              |
| gizzard shad adult                | 12           | 91.7                 | 100.0              | 91.7               |

Comparisons of extended survival rates estimated from this evaluation were compared to extended survivals from previous evaluations in 1987 and 1990–1991 (Table 2-5). There was an overall improvement in the extended survivals of all species. Most notably, "fragile" species, including alewife (*Alosa pseudoharengus*), gizzard shad (*Dorosoma cepedianum*), rainbow smelt (*Osmerus mordax*), and white perch (*Morone americana*), showed marked improvements in survival off the new prototype screen. Between the earlier and most recent evaluations, alewife

survival increased from <10% to 30%. Extended survival rates for juvenile gizzard shad increased from 27% to 95% during the winter, from 9% to 71% during the summer, and from 16–78% to 99% during the fall. Rainbow smelt survival increased significantly during the fall from a previous rate of 23–59% to a current rate of 76%. Overall, white perch survival increased from 56–57% in 1987 to 100% in 1998–1999.

**Table 2-5**  
**Comparison of 24-hr impingement survival rates of target fish species at Dunkirk Station before (1987 and 1990–1991) and after (1998–1999) installation of the prototype dual-flow traveling screen (Beak 2000a)**

| Species        | Life Stage | Season | 1987         |         | 1990–1991*   |           | 1998–1999    |       |
|----------------|------------|--------|--------------|---------|--------------|-----------|--------------|-------|
|                |            |        | Survival (%) | N       | Survival (%) | N         | Survival (%) | N     |
| alewife        | juvenile   | fall   | 4.1          | 73      | 8            | 25        | –            | –     |
|                |            | spring | –            | –       | –            | –         | 30           | 260   |
|                |            | summer | –            | –       | –            | –         | 0            | 12    |
| emerald shiner | juv/adult  | winter | 72.3–96.2    | 65–130  | –            | –         | 98.2         | 3,738 |
|                |            | spring |              |         | –            | –         | 95           | 2,564 |
|                |            | summer | 42.4         | 33      | –            | –         | 67.3         | 46    |
|                |            | fall   | 80.0–88.4    | 60–146  | 66.9–88.4    | 251–3,540 | 98           | 6,072 |
| gizzard shad   | juvenile   | winter | 26.7         | 30      | –            | –         | 94.7         | 1,927 |
|                |            | spring |              |         | –            | –         | 64.9         | 211   |
|                |            | summer | 9.1          | 44      | –            | –         | 70.7         | 288   |
|                |            | fall   | 48.9–77.8    | 135–235 | 16.1         | 221       | 98.6         | 1,488 |
| rainbow smelt  | juv/adult  | winter | 58.7–91.2    | 34–225  | –            | –         | 83.2         | 614   |
|                |            | spring | 53.6         | 97      | –            | –         | 63.2         | 318   |
|                |            | summer |              |         | –            | –         | 18.8         | 48    |
|                |            | fall   | 37.8–58.7    | 49–148  | 22.7–48.0    | 995–1,835 | 75.9         | 473   |
| white bass     | juv/adult  | winter | 81.2         | 32      | –            | –         | 100          | 1     |
|                |            | spring | 51.1         | 45      | –            | –         | 100          | 1     |
|                |            | summer | 54           | 37      | –            | –         | 83.3         | 6     |
|                |            | fall   | 97.9         | 47      | 85.7         | 7         | 98.6         | 147   |
| white perch    | juv/adult  | winter | 56.7         | 30      | –            | –         |              |       |
|                |            | spring | 56.2         | 48      | –            | –         | 100          | 2     |
|                |            | summer | 56.7         | 30      | –            | –         | 100          | 22    |
|                |            | fall   | –            | –       | 63.5         | 665       | 100          | 45    |
| yellow perch   | juv/adult  | winter | –            | –       | –            | –         | 100          | 66    |
|                |            | summer | –            | –       | –            | –         | 92.9         | 14    |
|                |            | fall   | 93.8         | 32      | 81.3         | 16        | 98.9         | 178   |

\*tests conducted August 1990-January 1991

N = sample size

Suggestions for the optimization of the prototype screen and fish return system included reducing the outside spray wash header pressure to 5 psi minimizing the gap between the flap seal and the descending screen, and either discontinuing the use of the lower outside spray wash nozzles or readjusting their angles.

### **Huntley Steam Station**

A fish survival study was conducted at the Huntley Steam Station (Huntley), on the Niagara River, in the town of Tonawanda, NY. The study was designed to assess the biological efficacy of five new flow-through Ristroph modified screens in the screenhouse that services Units 67 and 68 (Beak 2000b). The study assessed: 1) the effectiveness of the low pressure spraywash to remove fish from the screens; 2) the influence of collection and handling on the survival of impinged fish; 3) estimated post-impingement survival of impinged fish and 4) to determine ways to optimize post-impingement survival.

Huntley is a four unit, coal-fired facility with a combined output of 760 MW. The intake, located on a bulk-headed shoreline, withdraws water from the Niagara River. Water enters a common forebay under a skimmer wall. The forebay has five sets of bar racks and traveling screens, which are located 3.66 m (12 ft) downstream of each bar rack. The traveling screen slots are approximately 3.4 by 6.1 m (11 by 20 ft). The new screens were manufactured by Bracket-Green and used 3.2- by 12.7-mm (1/8- by 1/2-in.) “smooth tex” woven stainless steel mesh. The screens had separate fish and debris troughs. Fish were removed from the descending screen faces with two inside and two outside low-pressure spray washes. Fish and debris troughs combined into a single 45.7-cm (18-in.) diameter pipe before discharging into the Niagara River approximately 106.7 m (350 ft) downstream of the intake.

To determine the efficacy of the spray wash to remove fish from the screens, a mark/recapture study was undertaken. Two to four marked fish were placed in the fish lifting buckets on the ascending screen. Fish that were removed by the spray wash system were collected in baskets designed to fit in the fish and debris trough. The majority of testing was conducted with screens #5 and #6 because they were the most easily accessible. During testing there was little or no debris on the screens, and they were rotated continuously at 2.44 m/min (8 ft/min); the normal operating speed.

Dead Centrarchids (bluegill [*Lepomis macrochirus*] and pumpkinseed [*Lepomis gibbosus*]) were stained and used in tests to optimize spraywash pressure. Twenty-five fish ranging in size from 94 to 161 mm (3.7 to 6.3 in.) were tested with four different spray pressures, 1.5, 5, 8, and 10 psi. Smaller dead emerald shiners (*Notropis atherinoides*) (70 to 100 mm [2.8 to 3.9 in.]) were tested to determine if size and fish shape affected collecting efficiency. In addition, dead rainbow smelt (in two size classes, 75 to 95 mm [3.0 to 3.7 in.] and 130 to 140 mm [5.1 to 5.5 in.]) were tested at 5 psi only. Finally, numbers of “naturally impinged” rainbow smelt (*Osmerus mordax*) and emerald shiners (*Notropis atherinoides*) caught in the fish and debris trough were compared.

Post-impingement survival tests were conducted at Huntley in January and October 1999. In early January, 85 golden shiners (*Notemigonus crysoleucas*), obtained through commercial vendors, were handled and/or held for 24 hrs to determine the effect of handling and holding on survival. Forty-nine of the 85 fish were introduced upstream of the impingement collection device in the fish return trough (handling controls), while the remaining 36 golden shiners were placed directly in the holding tanks (holding controls). Extended survival of all 85 fish was

100% at the 24-hr period. Therefore, no adjustments were made to the impingement mortality estimates to account for handling or holding mortality.

The primary objective of the impingement survival test was to assess the effectiveness of the screens with four target species (alewife [*Alosa pseudoharengus*], emerald shiner, gizzard shad [*Dorosoma cepedianum*], and rainbow smelt). During January testing, an attempt was made to assess 200 fish from each of the four target species, such that results would be statistically reliable. Additional testing was conducted in October, specifically to supplement the data for alewife, since the 200 fish target for alewife was not achieved in January. Other species were collected and tested when additional holding space was available.

Eight-hr samples were collected on five nights from January 21–25, 1999, and October 24–29, 1999. During sampling, the modified traveling screens were rotated continuously at 2.44 m/min (8 ft/min). All fish from Screens #5 and #6 were diverted into a collection table. Sampling was conducted continuously for up to 2 hrs but was shortened when large numbers of fish were impinged. Sampling was interrupted to move fish when necessary. Fish were removed from the collection table using a brailing device that maintained a minimum of 101.4 mm (4 in.) of water and minimized handling stress. Fish were held in large fiberglass or galvanized steel tanks (ranging in size from 75.7 to 908.5 liters [20 to 240 gal]) and supplied with a continuous supply of water pumped from the forebay. Flow into the tanks was continuous and provided a moderate circular current. Water in the holding tanks was exchanged three to five times per hr. No more than 5 g of fish per liter of water were held in any of the tanks. Fish were separated by size and predator and prey species were separated. The initial condition of all fish was assessed prior to being placed into the holding tanks. Three categories of condition were used to characterize fish condition: 1) live – no visible physical damage, fish actively swimming, and oriented in a normal upright position; 2) stressed – fish with visible physical damage such as missing patches of scales, torn fins, hemorrhaging or gouging, and/or weak swimming ability or fish having difficulty maintaining position; or 3) dead – fish with no obvious external signs of life and/or severely damaged or mutilated individuals with only slight opercular movement. Only live fish were transferred to the holding tanks and held for 24 hrs to determine latent mortality.

Recovery rates for Centrarchids ranged from 88% to 100% (Table 2-6). The best transfer efficiencies occurred at pressures of 1.5 and 5 psi. In most cases, fish that were not transferred to the fish return system were captured in the debris trough. Differences in efficiency between screens were attributed to differences in orientation of the internal and external spray washes and/or differences in pressures between internal and external spray washes.

Tests conducted on Screen #6 with dead emerald shiners showed that only 37% of the fish were collected in the fish return trough (Table 2-7). The remaining shiners were collected in the debris trough. Recovery of larger fish was greater than for smaller fish. In tests with two sizes of rainbow smelt, the collection efficiency ranged from 42 to 63% for juvenile fish (75 to 95 mm [3.0 to 3.7 in.]) and for adult rainbow smelt (130 to 140 mm [5.1 to 5.5 in.]) collection efficiency ranged from 86 to 98% (Table 2-7). Regardless of size, the combined efficiency of both troughs ranged from 89 to 100%.

Collections of live impinged fish from the fish return and debris troughs downstream of Screens #5 and 6 indicated that 83% of the emerald shiners and 91% of the rainbow smelt were collected from the fish return trough (Table 2-8). Observed recovery of live fish (Table 2-7) was



substantially higher than similarly sized dead fish. This confirms previous observations of fish recovery from laboratory studies conducted at Alden Research Laboratory, Inc (Alden 2000).

A total of 6,120 fish were collected during the January impingement survival testing. Rainbow smelt were the most numerous fish collected (3,418). Overall survival of rainbow smelt was 84.2%. Rainbow smelt ranged in size from 56 to 140 mm (2.2 to 5.5 in.). Distribution in fish length was bimodal with peaks representing juvenile and adult fish. The division between the two age classes was at approximately 100 mm (3.9 in.). The extended survival of juvenile and adult rainbow smelt was 74.4% and 94.3%, respectively, with a total impingement survival of 84.2% (Table 2-9). The extended survival of emerald shiner (48 to 105 mm [1.9 to 4.1 in.]) was 97.5% (Table 2-9). Juvenile gizzard shad ranging in length from 86 to 193 mm (3.4 to 7.6 in.) had overall survival of 5.1% and initial survival of 14.9%. The three adult shad collected were severely stressed and did not survive. The authors believe that the low survival of gizzard shad could be partially attributed to thermal stress incurred as a result of the cold water temperatures (~0°C [32°F]). A total of 30 alewife were collected during January (four dead and 26 stressed). As with the gizzard shad, the authors speculate that cold water temperatures may have contributed to the poor survival observed.

Ten species of non-target species were collected during the study: trout-perch (*Percopsis omiscomaycus*), yellow perch (*Perca flavescens*), rock bass (*Ambloplites rupestris*), spottail shiner (*Notropis hudsonius*), white sucker (*Catostomus commersonii*), white perch (*Morone Americana*), smallmouth bass, bluntnose minnow (*Pimephales notatus*), darters, and redhorse sucker (*Moxostoma* spp.). With the exception of trout-perch, these species were collected in small numbers. The total survival of the non-target species ranged from 37.5% (white perch) to 100% (trout-perch, yellow perch, white sucker, smallmouth bass, bluntnose minnow, darter, and redhorse sucker) (Table 2-9).

A total of 3,258 fish were collected during the October impingement survival testing. Extended survival of rainbow smelt was estimated to be 48.0% (Table 2-10), which is lower than the reported survival of rainbow smelt in January. Survival of emerald shiner was high in October (97.5%) and roughly equal to what was observed in January (97.3%).

Based upon length frequencies, the gizzard shad tested in October were almost exclusively juveniles. The survival rate for gizzard shad in October was substantially higher than what was observed in January, i.e., 22.4% vs. 0%. Water temperatures were well above (11.5 to 14°C [52.7 to 57.2 °F]) those that caused thermal stress for gizzard shad during the January sampling efforts, thus possibly accounting for the higher survival. Alewife tested in October ranged in length from 79 to 134 mm (3.7 to 5.3 in.) and probably included young-of-the-year fish. The total survival of alewife during October was 22.4%.

Several of the non-target species collected in large enough numbers during October to be statistically reliable exhibited high total survival rates (e.g., spottail shiner, 97.8% ( $n=231$ ); rock bass, 98.9% ( $n=180$ ); and white bass (*Morone chrysops*), 97.6% ( $n=127$ )).

**Table 2-6**  
**Collection efficiency results for Centrarchids (Beak 2000b)**

| Screen | Fish Return Trough   |      |     |      | Fish Return and Debris Trough |      |     |      |
|--------|----------------------|------|-----|------|-------------------------------|------|-----|------|
|        | Spray Pressure (psi) |      |     |      | Spray Pressure (psi)          |      |     |      |
|        | 1.5                  | 5.0  | 8.0 | 10.0 | 1.5                           | 5.0  | 8.0 | 10.0 |
| #5     | 100%                 | 100% | 94% | 92%  | 100%                          | 100% | 98% | 98%  |
| #6     |                      | 98%  |     |      |                               | 100% |     |      |
| #7     |                      | 88%  |     |      |                               | NA   |     |      |
| #8     |                      | 100% |     |      |                               | NA   |     |      |
| #9     |                      | 100% |     |      |                               | NA   |     |      |

NA = Debris trough was inaccessible.

**Table 2-7**  
**Collection efficiency results for emerald shiner and rainbow smelt at the Huntley Station (5 psi only) (Beak 2000b)**

| Screen | Fish Return Trough |               |            | Fish Return and Debris Trough |               |            |
|--------|--------------------|---------------|------------|-------------------------------|---------------|------------|
|        | Emerald Shiner     | Rainbow Smelt |            | Emerald Shiner                | Rainbow Smelt |            |
|        |                    | Juvenile      | Adult      |                               | Juvenile      | Adult      |
|        | 70–100 mm          | 75–95 mm      | 130–140 mm | 70–100 mm                     | 75–95 mm      | 130–140 mm |
| #5     |                    | 63%           | 98%        |                               | 89%           | 100%       |
| #6     | 37%                | 42%           | 86%        | 100%                          | 96%           | 96%        |
| #9     |                    | 52%           | 88%        |                               | NA            | NA         |

**Table 2-8**  
**Numbers of naturally impinged fish collected in fish and debris troughs at Huntley Station (Beak 2000b)**

| Species        | Size (mm) | Number of Fish Recovered from Trough | Number of Fish Recovered from Debris Trough | Percent of Recovered Fish Collected in Fish Trough |
|----------------|-----------|--------------------------------------|---------------------------------------------|----------------------------------------------------|
| emerald shiner | 70–100    | 104                                  | 22                                          | 83%                                                |
| rainbow smelt  | 75–140    | 995                                  | 95                                          | 91%                                                |

**Table 2-9**  
**Results of impingement survival testing, Huntley Station, January, 1999 (Beak 2000b)**

| Species                  | Initial |          |       | Initial Survival | 24-Hr |          |       | 24-Hr Survival | Total Tested | Total Survival |  |
|--------------------------|---------|----------|-------|------------------|-------|----------|-------|----------------|--------------|----------------|--|
|                          | Dead    | Stressed | Alive |                  | Dead  | Stressed | Alive |                |              |                |  |
| rainbow smelt*           | 32      | 29       | 3,357 | 98.2%            | 430   | 49       | 2,878 | 85.7%          | 3,418        | 84.2%          |  |
| emerald shiner*          | 14      | 19       | 2,168 | 98.5%            | 19    | 3        | 2,146 | 99.0%          | 2,201        | 97.5%          |  |
| gizzard shad "juvenile"* | 32      | 236      | 47    | 14.9%            | 25    | 6        | 16    | 34.0%          | 315          | 5.1%           |  |
| trout-perch              | 0       | 0        | 67    | 100.0%           | 0     | 0        | 67    | 100.0%         | 67           | 100.0%         |  |
| alewife*                 | 4       | 26       | 0     | 0.0%             |       |          |       |                | 30           | 0.0%           |  |
| yellow perch             | 0       | 0        | 20    | 100.0%           | 0     | 0        | 20    | 100.0%         | 20           | 100.0%         |  |
| rock bass                | 1       | 1        | 17    | 89.5%            | 0     | 0        | 17    | 100.0%         | 19           | 89.5%          |  |
| spottail shiner          | 0       | 1        | 17    | 94.4%            | 0     | 0        | 17    | 100.0%         | 18           | 94.4%          |  |
| white sucker             | 0       | 0        | 11    | 100.0%           | 0     | 0        | 11    | 100.0%         | 11           | 100.0%         |  |
| white perch              | 4       | 1        | 3     | 37.5%            | 0     | 0        | 3     | 100.0%         | 8            | 37.5%          |  |
| gizzard shad "adult"*    | 0       | 3        | 0     | 0.0%             |       |          |       |                | 3            | 0.0%           |  |
| smallmouth bass          | 0       | 0        | 3     | 100.0%           | 0     | 0        | 3     | 100.0%         | 3            | 100.0%         |  |
| bluntnose minnow         | 0       | 0        | 3     | 100.0%           | 0     | 0        | 3     | 100.0%         | 3            | 100.0%         |  |
| darter                   | 0       | 0        | 2     | 100.0%           | 0     | 0        | 2     | 100.0%         | 2            | 100.0%         |  |
| redhorse sucker          | 0       | 0        | 2     | 100.0%           | 0     | 0        | 2     | 100.0%         | 2            | 100.0%         |  |
|                          |         |          |       |                  |       |          |       |                | <b>Total</b> | <b>6,120</b>   |  |

\* Target species

**Table 2-10**  
**Results of impingement survival testing, Huntley Station, October, 1999 (Beak 2000b)**

| Species          | Initial |          |       | Initial Survival | 24-Hr |          |       | 24-Hr Survival | Total Tested | Total Survival |
|------------------|---------|----------|-------|------------------|-------|----------|-------|----------------|--------------|----------------|
|                  | Dead    | Stressed | Alive |                  | Dead  | Stressed | Alive |                |              |                |
| rainbow smelt*   | 282     | 81       | 1,461 | 80.1%            | 584   | 2        | 875   | 59.9%          | 1,824        | 48.0%          |
| emerald shiner*  | 5       | 2        | 621   | 98.9%            | 9     | 1        | 611   | 98.4%          | 628          | 97.3%          |
| spottail shiner  | 2       | 2        | 227   | 98.3%            | 1     | 0        | 226   | 99.6%          | 231          | 97.8%          |
| alewife*         | 0       | 2        | 181   | 98.9%            | 139   | 1        | 41    | 22.7%          | 183          | 22.4%          |
| rock bass        | 0       | 2        | 178   | 98.9%            | 0     | 0        | 178   | 100.0%         | 180          | 98.9%          |
| white bass       | 0       | 2        | 125   | 98.4%            | 1     | 0        | 124   | 99.2%          | 127          | 97.6%          |
| gizzard shad*    | 0       | 0        | 65    | 100.0%           | 2     | 0        | 63    | 96.9%          | 65           | 96.9%          |
| smallmouth bass  | 0       | 0        | 6     | 100.0%           | 0     | 0        | 6     | 100.0%         | 6            | 100.0%         |
| darther          | 0       | 0        | 5     | 100.0%           | 0     | 0        | 5     | 100.0%         | 5            | 100.0%         |
| white perch      | 0       | 0        | 4     | 100.0%           | 0     | 0        | 4     | 100.0%         | 4            | 100.0%         |
| yellow perch     | 0       | 0        | 1     | 100.0%           | 0     | 0        | 1     | 100.0%         | 1            | 100.0%         |
| brook silverside | 0       | 0        | 1     | 100.0%           | 0     | 0        | 1     | 100.0%         | 1            | 100.0%         |
| pumpkinseed      | 0       | 0        | 1     | 100.0%           | 0     | 0        | 1     | 100.0%         | 1            | 100.0%         |
| goldfish         | 0       | 0        | 1     | 100.0%           | 0     | 0        | 1     | 100.0%         | 1            | 100.0%         |
| black crappie    | 0       | 0        | 1     | 100.0%           | 0     | 0        | 1     | 100.0%         | 1            | 100.0%         |
| <b>Total</b>     |         |          |       |                  |       |          |       |                | <b>3,258</b> |                |

\* Target species

## **Salem Generating Station**

An evaluation of the biological effectiveness of the modified traveling screens at the Salem Generating Station on Delaware Bay in New Jersey was conducted in 1995 (Ronafalvy et al. 2000; Heimbuch 1999). An initial evaluation was performed after six of the 12 existing traveling water screens at the cooling water intake structure had been replaced with the new, improved screens, allowing a side-by-side comparison of the effectiveness of the old and new screens (the other six screens have since been replaced). The new screens incorporated the hydrodynamically improved fish buckets (as described previously; Fletcher 1990), smooth woven mesh screens (1.6 by 12.7 mm [1/4 by 1/2 in.] rectangular mesh), lighter composite screen baskets that allow for increased rotational speed, improved low and high pressure spray washes (orientation and pressures), and an improved screen-to-collection trough flap seal design. Tests were conducted on 19 separate dates between June 20 and August 24, 1995. Fish collected from the old and new screens were held separately for observation of 48-hr survival. The only species occurring in sufficient numbers to provide a statistically valid data analysis was juvenile weakfish (*Cynoscion regalis*) (n = 1,082 for the old screens, n = 1,559 for the new screens). Overall, statistical analyses demonstrated a 48-hr survival rate (uncorrected for control mortality) of 57.8% with the old screens and 79.3% with the new screens. Temperature had a significant influence on test results. At the lowest ambient temperature (23°C [73 °F]), survival with the old and new screens was 88.0 and 97.7%, respectively. At the highest temperature (27°C [80°F]), survival was 35.1% for the old screens and 55.6% with the new screens. Fish length also influenced survival. For fish <50 mm (<2.0 in.) (TL), survival with the old and new screens was 73.7 and 85.5%, respectively. For fish >50 mm (>2.0 in.), survival with the old and new screens was 57.5 and 82.3%, respectively.

A second series of impingement survival studies was conducted in 1997 and 1998 to provide estimates of impingement survival rates with all of the modified screens installed on Salem Units 1 and 2 (Heimbuch 1999). Samples were collected about twice a week from October through December 1997 and from April through September 1998. Samples were taken within a 10-hr period each day and usually included the entire ebb tide and the beginning of the flood tide. Screen washwater was diverted into a sampling pool, where fish were separated by species and size, counted, and classified by condition before being moved into holding tanks for latent survival observations. Latent survival evaluations were made at 24 and 48 hrs.

White perch (*Morone americana*) impingement survival rate estimates ranged from 98% in December to 93% in April. Estimates for weakfish (*Cynoscion regalis*) ranged from 88% in September to 18% in July. For bay anchovy (*Anchoa mitchilli*), survival estimates ranged from 72% in November to 20% in July. Atlantic croaker (*Micropogonias undulatus*) survival estimates ranged from 98% in November to 58% in April. The estimated survival for spot was 93% in November (November was the only month in which a significant number of spot were collected). *Alosa* spp. combined produced survival estimates that ranged from 82% in April to 78% in November (Table 2-11).

**Table 2-11**  
**Results of 1997–1998 impingement survival study — Salem Generating Station (Heimbuch 1999)**

| Species           | Month     | Number of Fish Examined | Impingement Survival Rate (Initial Plus 18 Hr Latent) |
|-------------------|-----------|-------------------------|-------------------------------------------------------|
| weakfish          | June      | 846                     | 21                                                    |
|                   | July      | 1,172                   | 18                                                    |
|                   | August    | 1,076                   | 62                                                    |
|                   | September | 278                     | 88                                                    |
| white perch       | April     | 89                      | 93                                                    |
|                   | November  | 602                     | 93                                                    |
|                   | December  | 345                     | 98                                                    |
| bay anchovy       | April     | 329                     | 46                                                    |
|                   | May       | 239                     | 45                                                    |
|                   | June      | 161                     | 22                                                    |
|                   | July      | 54                      | 20                                                    |
|                   | October   | 311                     | 65                                                    |
|                   | November  | 142                     | 72                                                    |
| Atlantic croaker  | April     | 184                     | 58                                                    |
|                   | May       | 751                     | 66                                                    |
|                   | June      | 724                     | 72                                                    |
|                   | July      | 68                      | 65                                                    |
|                   | October   | 213                     | 95                                                    |
|                   | November  | 214                     | 98                                                    |
|                   | December  | 890                     | 85                                                    |
| spot              | November  | 91                      | 93                                                    |
| <i>Alosa</i> sp.* | April     | 38                      | 82                                                    |
|                   | November  | 102                     | 78                                                    |

\*alewife (*Alosa pseudoharengus*), blueback herring (*Alosa aestivalis*), and American shad (*Alosa sapidissima*) combined

Impingement mortality rates for the modified screens (1997-1998 and 1995 studies) were compared to mortality rates for the original screens from the 1978 to 1982 and 1995 studies. Based on the comparisons, intake modifications were effective in improving the rates of fish survival (Table 2-12). Estimates of impingement mortality rates were lower for the modified screens than for corresponding estimates from the original screens for white perch, bay anchovy, Atlantic croaker, spot (*Leiostomus xanthurus*), and the *Alosa* spp.

**Table 2-12**  
**Estimated survival rates for original and modified screen at Salem Generating Station (Heimbuch 1999)**

| Species           | Month   | Original Screens                      |                                  | Modified Screens                 |                                       |
|-------------------|---------|---------------------------------------|----------------------------------|----------------------------------|---------------------------------------|
|                   |         | 1978–1982 Survival Rate Estimates (%) | 1995 Survival Rate Estimates (%) | 1995 Survival Rate Estimates (%) | 1997–1998 Survival Rate Estimates (%) |
| weakfish          | Jun     | 61                                    | 67                               | 83                               | 21                                    |
|                   | Jul     | 49                                    | 69                               | 82                               | 18                                    |
|                   | Aug     | 48                                    | 49                               | 75                               | 62                                    |
|                   | Sep     | 60                                    | -                                | -                                | 88                                    |
|                   | Oct     | 47                                    | -                                | -                                | -                                     |
| white perch       | Jan     | 87                                    | -                                | -                                | -                                     |
|                   | Feb     | 84                                    | -                                | -                                | -                                     |
|                   | Mar     | 88                                    | -                                | -                                | -                                     |
|                   | Apr     | 85                                    | -                                | -                                | 93                                    |
|                   | Oct     | 79                                    | -                                | -                                | -                                     |
|                   | Nov     | 84                                    | -                                | -                                | 93                                    |
|                   | Dec     | 92                                    | -                                | -                                | 98                                    |
| bay anchovy       | Apr     | -                                     | -                                | -                                | 46                                    |
|                   | May     | 19                                    | -                                | -                                | 45                                    |
|                   | Jun     | 11                                    | -                                | -                                | 22                                    |
|                   | Jul     | 10                                    | -                                | -                                | 20                                    |
|                   | Aug     | 15                                    | -                                | -                                | -                                     |
|                   | Sep     | 28                                    | -                                | -                                | -                                     |
|                   | Oct     | 35                                    | -                                | -                                | 65                                    |
|                   | Nov     | 68                                    | -                                | -                                | 72                                    |
| Atlantic croaker  | Apr     | -                                     | -                                | -                                | 58                                    |
|                   | May     | -                                     | -                                | -                                | 66                                    |
|                   | Jun     | -                                     | -                                | -                                | 72                                    |
|                   | Jul     | -                                     | -                                | -                                | 65                                    |
|                   | Oct     | -                                     | -                                | -                                | 95                                    |
|                   | Nov     | -                                     | -                                | -                                | 98                                    |
|                   | Dec-Jan | 51                                    | -                                | -                                | 85                                    |
| spot              | Jun     | 69                                    | -                                | -                                | -                                     |
|                   | Jul     | 52                                    | -                                | -                                | -                                     |
|                   | Aug     | 53                                    | -                                | -                                | -                                     |
|                   | Oct     | 62                                    | -                                | -                                | -                                     |
|                   | Nov     | 81                                    | -                                | -                                | 93                                    |
|                   | Dec     | 71                                    | -                                | -                                | -                                     |
| <i>Alosa</i> sp.* | Mar-Apr | 11                                    | -                                | -                                | 82                                    |
|                   | Oct-Dec | 69                                    | -                                | -                                | 78                                    |

\*Estimates for original screens are based on blueback herring only. Estimates for modified intake screens are based on *Alosa* spp., i.e., blueback herring, alewife, and American shad combined.

Mortality estimates of weakfish in the modified screen study were compared to the weakfish estimates from the 1995 direct comparison study (as we discuss above). The results appeared to confirm the expectation that the modified screens improved survival. During the 1995 study,

estimates of weakfish mortality were lower on the modified screens than on the original screens in June and July. Similarly, 1997 and 1998 estimates of weakfish mortality rates were lower in August and September than the corresponding estimates from the 1978 to 1982 studies. However, weakfish mortality estimates from the 1997 and 1998 studies for June and July (modified screens) were higher than the June and July estimates from the 1978 to 1982 studies (original screens).

The author provides several hypotheses for the inconsistencies mentioned above (Heimbuch 1999). The explanations include mechanical shortcomings, modifications to the fish return system, and changes in experimental protocol. Gaps may have existed between the flap seals that separate the fish and debris troughs, allowing fish to be subjected to the additional stress of heavy debris. The J-shaped fish-return slide leading into the collection pool was changed to a configuration where a vertical stop was placed at the end of the slide, creating a more stressful entry into the collection pool. An additional factor that may have biased mortality estimates without affecting mortality was the type of screen installed in the fish collection pools. During the 1978 to 1982 and 1995 studies, a 9.5-mm (3/8-in.) square mesh was used in the fish collection pools. The 1997 and 1998 studies used a screen with smaller pore openings in the collection pool. The larger mesh size may have allowed smaller fish to escape collection, and since smaller fish generally exhibit higher mortality to stress. The loss of these fish may have induced a downward bias in mortality estimates in 1995 for both screen types.

### ***Calvert Cliffs Nuclear Power Plant***

Calvert Cliffs Nuclear Power Plant (CCNPP) is located on the western shore of the Chesapeake Bay in Calvert County, Maryland about 14.5 km (9 miles) north of the Patuxent River and approximately 64 km (40 miles) from Washington, D. C. Cooling water for the plant is drawn from the Bay through a 1,463 m (4,800 ft) long intake channel. The intake basin is enclosed with a 171 m (561 ft) curtain wall, which extends to a depth of 8.5 m (27.9 ft). Six circulating water pumps provide a flow of 151.5 m<sup>3</sup>/sec (5,348 cfs). Velocity at the intake structure is approximately 0.3 m/sec (1 ft/sec). There are six intake bays and 12 traveling screens fitted with 9.5-mm (3/8-in.) square mesh for each of the units. The 12 screens are sequentially operated in pairs (two traveling screens for each bay) for 10 min each hr during normal plant operations. Organisms that are collected on the screens are removed with a high-pressure wash system and returned to the Bay through a drain system.

Impingement and survival studies have been conducted at CCNPP for 21 years, beginning in 1975 (Ringger 2000; Horwitz 1987). A full impact monitoring protocol was established by the Academy of Natural Sciences of Philadelphia before the plant went online in 1975 and was continued through 1995. In 1981, in response to Section 316(b) of the Clean Water Act, a formal report was prepared. The report, along with continued studies and regulatory evaluations, supported the subsequent renewals of the facility's discharge permit.

Over the 21-year period of study, many variations and modifications were made; however, a basic study protocol was followed. A 1.27-cm (1/2-in.) mesh nylon net was placed in the screen wash discharge trough and left in place for 1 hr. One-hr collections were made over a 6-day period at various intervals in order to include all hrs and tidal events (this process was scaled back to 4- and 5-day periods starting in 1994). All organisms collected by were identified by species and counted. Up to 50 of each species were weighed, measured, and examined for



external injuries. Monthly estimates of impingement, monthly impingement rates, and estimated annual impingement for each species was calculated from the number and weights of the sample collections.

A total of 73 species of finfish were collected over the 21 years of sampling. The number of species collected ranged from an annual low of 20 (1987 and 1991) to a high of 51 in 1976. Eight species were collected in all of the 21 years of sampling.

Bay anchovy (*Anchoa mitchilli*) and hogchoker (*Trinectes maculatus*) were among the species collected and ranked in the top five most abundant species collected in all 21 years of sampling. Annual plant impingement numbers range from 79,081 in 1992 to over 9.6 million in 1984. The 1984 impingement number accounted for more than one-third of the total fish impinged over 21 years. The authors correlated times of episodic impingement of fish with environmental events such as “cold shock” and periods of low dissolved oxygen. In general, spring and summer were the times when most of the fish were collected. Blue crab (*Callinectes sapidus*) abundance was more variable, with high numbers reported in the spring, summer, or fall. The total estimated impingement of blue crabs was greater than 13 million for the 21-year period. Survival rate of blue crabs (99.46%) suggested that actual daily mortality could be less than 10 crabs per day over the 21 years of study.

Survival studies were conducted from 1975 to 1981 to determine initial mortality of organisms collected by the screens. Fish that were involved in periodic events of high impingement due to low dissolved oxygen levels were excluded from the survival studies. Over 100,000 individuals representing 57 species were included in the study. Eleven of the 14 most numerous species collected during the study had an estimated initial survival rate of 50% or higher.

Overall survival did not differ significantly between Units 1 and 2. In 1981, a separate study was conducted with smaller mesh-size screens. Although the smaller screens were able to collect smaller organisms, and therefore caught greater numbers of individuals, the difference between the screen types was not found to be significant.

### **Somerset Station**

Beginning in December 1982, an aquatic monitoring program, including the evaluation of 1-mm (0.04-in.) fine-mesh Ristroph traveling screens, was conducted at Somerset Station (formerly known as Kintigh Station), in part to meet the requirements of the plant’s NPDES Permit (McLaren and Tuttle 2000; NYSEG et al. 1990). Somerset Station has a generating capacity of 625 MW and is located on the south shore of Lake Ontario in Somerset, New York.

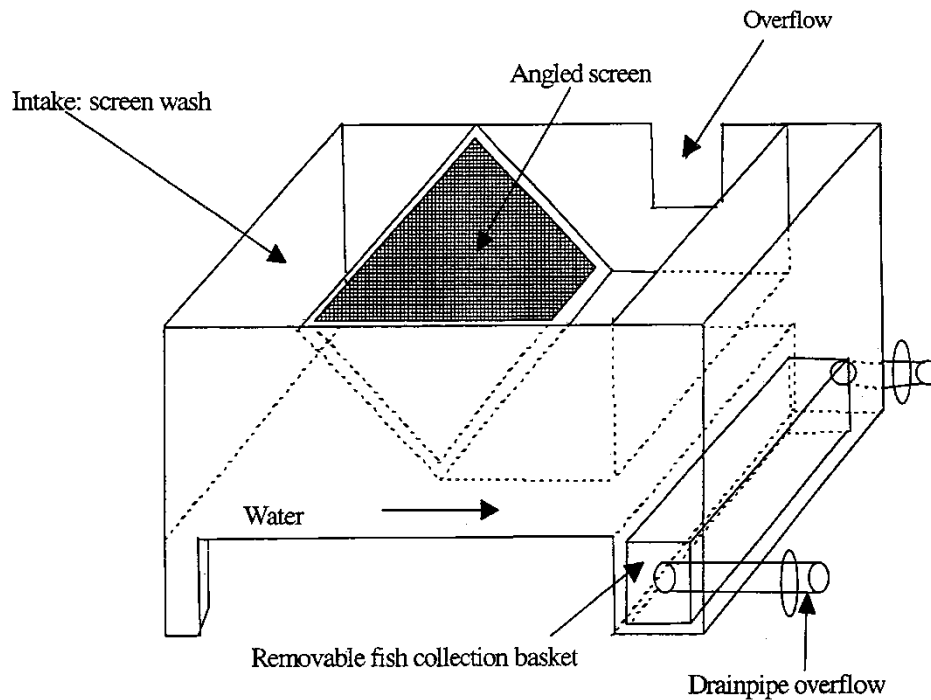
The station draws water through a capped offshore intake structure with 8 intake ports located approximately 7 m (23 ft) below the water surface and 1.8 m (5.9 ft) from the lake bottom. Cooling water for the once-through system is transported via a 625 m (2,051 ft) intake tunnel into the intake forebays. Three circulating pumps rated at 12.3 m<sup>3</sup>/sec (435 cfs) draw water through four vertical traveling screens fitted with 1 mm (0.04 in.) smooth nylon mesh. Velocities approaching the screens range from 0.27 to 0.33 m/sec (0.88 to 1.08 ft/sec).

Fish collected on the screens are removed with a low-pressure backwash system and are washed into a fiberglass fish trough, which leads into a fiberglass return pipe that discharges fish to the lake, 305 m (1,000 ft) offshore. Debris is removed from the screens with a high-pressure (60 psi)

spray located beneath the fish trough. Washings from the high-pressure spray are emptied into a concrete trough terminating in a debris collection basket.

The efficiency of fish removal from the traveling screens (collection efficiency), as well as survival testing, was evaluated at Somerset Station beginning in 1984. Various operational modes and spray wash configurations were tested to determine optimal performance from the screen removal/return system. Tests to evaluate collection efficiency involved the release and recapture of marked fish introduced into the collection system.

The effectiveness of the 1.0 mm (0.04 in.) fine-mesh screening system was evaluated using a special screening device placed into the collection pool. The screening device was designed to separate larger fish from fish that would normally pass through 9.5-mm mesh (3/8-in.) and become entrained. The device was a hinged, flat, horizontal screen with 9.5-mm (3/8-in.) mesh (Figure 2-7).



**Figure 2-7**  
**Somerset Station fish collection table (McLaren and Tuttle 2000)**

Larger fish that remained in the collection table upstream of the angled screen were referred to as “impinged,” whereas fish that passed through the coarse mesh (9.5 mm [3/8 in.]) were referred to as “entrapped.” Impinged and entrapped fish were collected, separated by condition, and placed into holding tanks. Fish were held for 96 hrs and were observed at 2, 4, 6, 8, 12, 24, 48, and 96 hrs. Dead fish were removed at each interval and identified. After 96 hrs, the remaining fish were identified to species, counted according to condition, and sorted by size (entrapped vs. impinged) using the screening table.

Impingement survival rates were highly variable for the species most commonly collected (principally juveniles and some adults of small species). Alewife (*Alosa pseudoharengus*)

exhibited the lowest 96-hr survival rate. Survival for alewife dropped to almost 0% in spring and increased to 44.5% in the summer of 1989 after modifications to the screening system were made. Rainbow smelt seasonal 96-hr survival rates were also variable, ranging from a high of 94.9% in spring of 1985 to lows of 1.5% and 21.8% in summer and fall, respectively. Ninety-six-hr survival of other species, with the exception of gizzard shad (*Dorosoma cepedianum*) (53.7 to 65.3%) exceeded 70 to 80% (Table 2-13).

**Table 2-13**  
**Initial and 96-hr seasonal survival rates of impinged fish at Somerset Station for frequently impinged species (McLaren and Tuttle 2000)**

| Species         | Season | Year | N     | Initial Survival (%) | 96-Hr Survival (%) |
|-----------------|--------|------|-------|----------------------|--------------------|
| alewife         | spring | 1985 | 184   | 100.0                | 0.0                |
|                 |        | 1986 | 202   | 99.0                 | 1.0                |
|                 | summer | 1985 | 1,144 | 98.1                 | 15.4               |
|                 |        | 1986 | 905   | 97.7                 | 19.0               |
|                 |        | 1989 | 1,068 | 99.5                 | 44.5               |
| gizzard shad    | summer | 1986 | 695   | 99.6                 | 65.3               |
|                 | fall   | 1986 | 108   | 100.0                | 53.7               |
| rainbow smelt   | spring | 1985 | 1,459 | 99.4                 | 94.9               |
|                 | summer | 1985 | 65    | 63.1                 | 1.5                |
|                 | fall   | 1985 | 248   | 98.4                 | 21.8               |
| rock bass       |        | 1985 | 56    | 100.0                | 94.6               |
| spottail shiner | winter | 1985 | 107   | 100.0                | 100.0              |
|                 | spring | 1985 | 72    | 100.0                | 100.0              |
|                 | summer | 1985 | 62    | 100.0                | 95.2               |
|                 |        | 1986 | 56    | 100.0                | 83.9               |
|                 | fall   | 1985 | 408   | 100.0                | 100.0              |
|                 |        | 1986 | 113   | 100.0                | 100.0              |
| white bass      | fall   | 1985 | 461   | 100.0                | 95.9               |
| white perch     | winter | 1985 | 78    | 100.0                | 72.0               |
| yellow perch    | winter | 1985 | 47    | 100.0                | 80.9               |

The estimated 96-hr survival rates for entrapment-sized fish were similar to rates for impingement-sized fish. The authors suggest that the survival rates reported should be considered conservative estimates. The impact of handling and holding stress on survival could not be determined because control groups were not used.

### **Arthur Kill Station**

Consolidated Edison Company of New York, Inc., (Con Ed) modified two of the dual-flow intake screens at the Arthur Kill Station as a requirement of a Consent Order mandated by Section 316(b) of the Clean Water Act (Con Ed. 1996). The station is located on Staten Island, New York, along the eastern bank of the Arthur Kill tidal strait, across from the mouth of the

Rahway River. Its two generating units (Units 20 and 30) have rated capacities of 360 and 515 MW, respectively. During the study, the station was operated on a seasonal schedule from June through September, with a reserve shutdown period occurring from October through May. The capacity of Unit 20 is 16.4 m<sup>3</sup>/sec (580 cfs), whereas Unit 30 has a capacity of 14.8 m<sup>3</sup>/sec (525 cfs). Water for each unit is drawn under debris curtains into four 3.4 by 7.9 m (11.2 by 26.0 ft) deep intake bays. The intake bays are fitted with 5 cm (2 in.) clear spacing trash racks that extend from the deck level to the bottom of the bay. Each unit is equipped with four dual-flow (double entry, single exit) intake screens (eight screens in total). The Unit 20 screens are fitted with 65 mesh panels, each 1.2 by 0.46 m (4 by 1.5 ft) wide. The Unit 30 screens contain 51 mesh panels, each 1.2 by 0.5 m (4 by 1.5 ft) wide. Both units have portal widths of 0.7 m (2.3 ft) on each side.

The velocity at the face of the screens at Unit 20, with the combined flow of both circulating and service water was 0.24 m/sec (0.8 ft/sec) at low tide and 0.18 m/sec (0.6 ft/sec) at high tide. Velocities at the face of the screens for Unit 30 were calculated at 0.40 m/sec (1.3 ft/sec) at low tide and 0.27 m/sec (0.9 ft/sec) at high tide.

Two of the dual-flow screens at the Arthur Kill Station underwent modifications to comply with the Consent Order. Screen No. 24 of Unit 20 and screen No. 31 of Unit 30 were equipped with fish-saving features, which included: smooth surface mesh, screen baskets with fish collection troughs, low-pressure spray wash systems, fish flap seals, and separate fish collection sluices. Screen No. 24 was fitted with 0.32 by 1.3 cm (1/8 by 1/2 in.) mesh on its screen baskets, while screen No. 31 was fitted with 0.64 by 1.3 cm (1/4 by 1/2 in.) mesh. The unmodified dual flow screens all had 0.32 by 0.32 cm (1/8 by 1/8 in.) mesh.

A total of 49 weekly impingement samples were collected from September 16, 1991, to September 10, 1992, with the exception of May 18 through June 1, 1992, when both units were shut down. The samples were collected from the washwater sluice for all eight dual-flow screens. Samples were separated by unit. The number of fish and blue crabs was recorded for each sample period. Three of the dual-flow screens, including No. 24 (modified), No. 31 (modified), and No. 23 (unmodified), were used for the post-impingement evaluation. Collections were made on a biweekly to monthly basis from February 1994 through July 1995. The majority of sampling occurred during the hrs of 7 p.m. and 5 a.m., with screens operating at a rotation speed of 6.1 m/min (20 ft/min). Fish and crabs were collected by diverting the screenwash water of the individual screens into a collection tank. Fish and crabs were separated into compatible groups and placed into holding tanks for 24-hr mortality evaluation. At the end of the holding period, fish and crabs were categorized by species and condition and counted.

The most abundant species collected during summer and early fall was bay anchovy (*Anchoa mitchilli*). Atlantic herring (*Clupea harengus*) were abundant in spring, and blueback herring (*Alosa aestivalis*) were abundant during late fall, winter, and early spring. The three aforementioned species made up 95.6% of the combined estimated impingement for Units 20 and 30. A total of 372,920 fish representing 72 species were collected from the Unit 20 and 30 sluices during the impingement study period.

Overall, bay anchovy was the most commonly impinged species (72.7%), followed by Atlantic herring (13.9%), and blueback herring (9.1%). Post-impingement survival studies resulted in the collection of 16,427 fish representing 59 taxa from one unmodified and two Ristroph-modified dual-flow screens between February 1994 and July 1995. Survival was calculated as the

percentage of fish alive at the end of the 24-hr latent mortality observation period relative to the total number of fish collected. The unmodified screen (No. 23) collected a total of 6,918 fish and had an average survival 15.2%. Screens 24 and 31 (modified) collected 6,472 and 3,037 fish and had survival rates of 78.9 and 92.4%, respectively. Survival after 24 hrs was generally higher on the Ristroph-modified dual-flow screens. Marked differences in survival on the modified and unmodified screens were observed for alewife, Atlantic herring, Atlantic silverside (*Menidia menidia*), bay anchovy, blueback herring, and weakfish (*Cynoscion regalis*) (Table 2-14).

**Table 2-14**

**Twenty-four hour post-impingement survival of fish collected from one unmodified and two Ristroph-modified dual-flow screens at the Arthur Kill Generating Station (Consolidated Edison Company 1996)**

| Species             | Unmodified Screen No. 23<br>(1/8-in. sq. Mesh) |                     |               | Ristroph-Modified Screen No. 24<br>(1/8 by 1/2-in. Mesh) |                     |               | Ristroph-Modified Screen No. 31<br>(1/4 by 1/2-in. Mesh) |                     |               |
|---------------------|------------------------------------------------|---------------------|---------------|----------------------------------------------------------|---------------------|---------------|----------------------------------------------------------|---------------------|---------------|
|                     | Number Collected                               | No. Alive at 24 Hrs | Percent Alive | Number Collected                                         | No. Alive at 24 Hrs | Percent Alive | Number Collected                                         | No. Alive at 24 Hrs | Percent Alive |
| alewife             | 20                                             | 1                   | 5.0           | 37                                                       | 35                  | 94.6          | 31                                                       | 30                  | 96.8          |
| American shad       | 11                                             | 1                   | 9.1           | 31                                                       | 24                  | 77.4          | 14                                                       | 11                  | 78.6          |
| Atlantic herring    | 1,038                                          | 1                   | 0.1           | 411                                                      | 90                  | 21.9          | 25                                                       | 10                  | 40.0          |
| Atlantic silverside | 186                                            | 94                  | 50.5          | 631                                                      | 617                 | 97.8          | 332                                                      | 329                 | 99.1          |
| Atlantic tomcod     | 3                                              | 1                   | 33.3          | 19                                                       | 18                  | 94.7          | 8                                                        | 8                   | 100.0         |
| bay anchovy         | 4,121                                          | 18                  | 0.4           | 836                                                      | 346                 | 41.4          | 193                                                      | 100                 | 51.8          |
| black sea bass      | 6                                              | 3                   | 50.0          | 17                                                       | 16                  | 94.1          | 13                                                       | 12                  | 92.3          |
| blueback herring    | 236                                            | 35                  | 14.8          | 1,686                                                    | 1,331               | 78.9          | 371                                                      | 355                 | 95.7          |
| butterfish          | 51                                             | 9                   | 17.6          | 54                                                       | 39                  | 72.2          | 71                                                       | 54                  | 76.1          |
| cunner              | 2                                              | 2                   | 100.0         | 8                                                        | 8                   | 100.0         | 8                                                        | 8                   | 100.0         |
| gizzard shad        | 1                                              | 0                   | 0.0           | 2                                                        | 2                   | 100.0         |                                                          |                     |               |
| menhaden            | 21                                             | 1                   | 4.8           | 49                                                       | 37                  | 75.5          | 34                                                       | 24                  | 70.6          |
| mummichog           | 40                                             | 38                  | 95.0          | 91                                                       | 84                  | 92.3          | 20                                                       | 16                  | 80.0          |
| Northern pipefish   | 132                                            | 132                 | 100.0         | 92                                                       | 89                  | 96.7          | 19                                                       | 19                  | 100.0         |
| Northern searobin   | 39                                             | 32                  | 82.1          | 133                                                      | 129                 | 97.0          | 52                                                       | 47                  | 90.4          |
| rainbow smelt       |                                                |                     |               | 57                                                       | 56                  | 98.2          | 21                                                       | 21                  | 100.0         |
| red hake            | 1                                              | 1                   | 100.0         | 1                                                        | 1                   | 100.0         | 5                                                        | 5                   | 100.0         |
| seaboard goby       | 13                                             | 13                  | 100.0         | 22                                                       | 22                  | 100.0         | 2                                                        | 2                   | 100.0         |
| seahorse            | 34                                             | 34                  | 100.0         | 47                                                       | 47                  | 100.0         | 27                                                       | 27                  | 100.0         |
| silver hake         | 13                                             | 2                   | 15.4          | 22                                                       | 18                  | 81.8          | 15                                                       | 15                  | 100.0         |
| silver perch        | 4                                              | 4                   | 100.0         | 26                                                       | 24                  | 92.3          | 18                                                       | 18                  | 100.0         |
| spotted hake        | 10                                             | 8                   | 80.0          | 55                                                       | 48                  | 87.3          | 19                                                       | 18                  | 94.7          |

| Species                | Unmodified Screen No. 23<br>(1/8-in. sq. Mesh) |                     |               | Ristroph-Modified Screen No. 24<br>(1/8 by 1/2-in. Mesh) |                     |               | Ristroph-Modified Screen No. 31<br>(1/4 by 1/2-in. Mesh) |                     |               |
|------------------------|------------------------------------------------|---------------------|---------------|----------------------------------------------------------|---------------------|---------------|----------------------------------------------------------|---------------------|---------------|
|                        | Number Collected                               | No. Alive at 24 Hrs | Percent Alive | Number Collected                                         | No. Alive at 24 Hrs | Percent Alive | Number Collected                                         | No. Alive at 24 Hrs | Percent Alive |
| striped anchovy        | 21                                             | 0                   | 0.0           | 15                                                       | 6                   | 40.0          | 18                                                       | 9                   | 50.0          |
| striped bass           | 8                                              | 4                   | 66.7          | 24                                                       | 22                  | 91.7          | 9                                                        | 7                   | 77.8          |
| striped killifish      | 44                                             | 40                  | 90.9          | 55                                                       | 48                  | 87.3          | 24                                                       | 23                  | 95.8          |
| summer flounder        | 4                                              | 1                   | 25.0          | 13                                                       | 8                   | 61.5          | 14                                                       | 7                   | 50.0          |
| threespine stickleback | 346                                            | 342                 | 98.8          | 880                                                      | 878                 | 99.8          | 639                                                      | 639                 | 100.0         |
| weakfish               | 319                                            | 134                 | 42.0          | 759                                                      | 695                 | 91.6          | 745                                                      | 721                 | 96.8          |
| white perch            | 27                                             | 17                  | 63.0          | 68                                                       | 61                  | 89.7          | 41                                                       | 35                  | 85.4          |
| windowpane flounder    | 12                                             | 10                  | 83.3          | 22                                                       | 21                  | 95.5          | 13                                                       | 11                  | 84.6          |
| winter flounder        | 121                                            | 50                  | 41.3          | 203                                                      | 197                 | 97.0          | 179                                                      | 174                 | 97.2          |

Post-impingement survival for blue crabs was 99.1% for the unmodified screen and 99.6% for the combined modified screens. A total of 220 blue crabs (*Callinectes sapidus*) were collected on the unmodified screen, and 1,029 were collected from the modified screens combined. The high survival rate of blue crabs on the unmodified screen suggests that the modifications made to the dual-flow screens may not be necessary for improving the protection of crabs.

Studies were conducted to determine if the handling/holding tank or the collection sluice could have a significant effect on post-impingement survival. Results suggested that post-impingement survival was affected by the handling/holding tank for bay anchovy, blueback herring, and Atlantic herring. Larger volume tanks appeared to improve survival of these species. Fish collected from the fish sluice generally had higher survival than those collected from the debris sluice, except for Atlantic herring.

### **Oswego Steam Station**

Oswego Steam Station is located on the southern shore of Lake Ontario in Oswego, New York. The station has six units, in which units 1 and 2 no longer operate. The remaining units have a combined generating capacity of 1,980 MW. Water is provided to the once-through cooling system by three offshore intakes.

Traveling screen sampling programs were conducted periodically over a 19-year period at Units 1–4. Impingement survival studies were conducted at Oswego Steam Station Units 1–4 from January 1973 through December 1975, from April 1982 through March 1983, and from January through December 1991 (LMS 1992). Seasonal impingement at the station was shown to be consistent, having peak impingements during the spring and the lowest impingement numbers in late summer and early fall. The alewife was the most commonly impinged, accounting for 85% of the annual total. The second most commonly impinged species was rainbow smelt, averaging 10% of the annual impingement.

Limited impingement monitoring studies were conducted at the Unit 5 intake. Relying on data from a 12-month study, alewife (*Alosa pseudoharengus*) was again the dominant species collected, making up 75.8% of the total impingement during 1975–1976 and 71.5% of the total impingement during 1991. The second most abundant species was threespine stickleback (*Gasterosteus aculeatus*) in 1975–1976 making up 14.6% of the total. Rainbow smelt (*Osmerus mordax*) was the third most abundant species in 1975–1976 and the second most abundant in 1991, accounting for 4.6% and 18.7% of the total yearly impingement numbers, respectively.

Post-impingement survival studies were conducted at Unit 5 during 1991. Alewife was the most abundant species collected and had a survival rate of 0.8%. Rainbow smelt, the second most abundant species, had a survival rate of 7.3%. A total of 4,826 fish representing 30 species was collected from the conventional traveling screens and observed for 24-hr survival. Other species collected and survival rates are listed in Table 2-15.



**Table 2-15**  
**Unit 5 conventional vertical traveling screen oost-impingement survival summary Oswego Steam Station 1991 (LMS 1992)**

| Species                | Collected | Initial Condition |         |       |                      | Condition at 24 Hrs                |      |         |      |                   | Survival (%) |
|------------------------|-----------|-------------------|---------|-------|----------------------|------------------------------------|------|---------|------|-------------------|--------------|
|                        |           | Live              | Stunned | Dead  | Initial Survival (%) | No. Examined for Extended Survival | Live | Stunned | Dead | Extended Survival |              |
| alewife                | 3,090     | 167               | 1,276   | 1,647 | 46.7                 | 679                                | 10   | 1       | 668  | 1.6               | 0.8          |
| rainbow smelt          | 1,189     | 67                | 109     | 1,013 | 14.8                 | 150                                | 50   | 24      | 76   | 49.3              | 7.3          |
| mottled sculpin        | 162       | 141               | 8       | 13    | 92.0                 | 145                                | 133  | 4       | 8    | 94.5              | 86.9         |
| spottail shiner        | 144       | 36                | 33      | 75    | 47.9                 | 64                                 | 34   | 12      | 18   | 71.9              | 34.4         |
| threespine stickleback | 52        | 23                | 8       | 21    | 59.6                 | 31                                 | 15   | 2       | 14   | 54.8              | 32.7         |
| gizzard shad           | 51        | 6                 | 26      | 19    | 62.7                 | 32                                 | 0    | 0       | 32   | 0.0               | 0.0          |
| emerald shiner         | 29        | 5                 | 3       | 21    | 27.6                 | 8                                  | 3    | 3       | 2    | 75.0              | 20.7         |
| others (23) species)   | 109       | 27                | 41      | 41    | 62.4                 | 66                                 | 36   | 12      | 18   | 72.7              | 45.4         |

## ***Belle River Power Plant***

A 1-year study was conducted at the Belle River Power Plant to determine the number of fish impinged on its traveling screens (Freshwater Physicians, Inc. 1991). The plant is located on the St. Clair River approximately 23 km (14.3 miles) south of Lake Huron. The 68.6 m (225 ft) wide intake structure is angled 20 degrees with respect to river flow and is equipped with 3.8 cm (1.5 in.) clear-spaced trash racks across its entire face. The trash rack turns the flow perpendicular to the face of the rack, which aids in the exclusion of debris and floating ice. A set of 45.7 cm (18 in.) guide vanes is located behind the trash racks to enhance parallel flow through the fish escapeway. Downstream of the fish escapeway are ten, flush mounted, 4.2 m (14 ft) wide traveling screens. The screen panels are fitted with 9.5 mm (3/8 in.) mesh screening. The orientation of the intake structure and trash racks functions much like a louver system in its ability to deter fish (Figure 2-8). In addition, the lateral water currents within the fish escapeway result in a flushing action across the face of the screen, possibly freeing impinged fish before the screen panels are rotated out of the water. There are three circulating pumps per unit, however, only one pump per unit is operated during winter months and two are operated during the remainder of the year. Cooling water is drawn into the intake at a flow rate of 8.2 m<sup>3</sup>/sec (289.7 cfs) with one pump operating and 14.5 m<sup>3</sup>/sec (512.5 cfs) with two. The approach velocities at the intake average around 0.15 m/sec (0.5 ft/sec) with a total flow of 41.7 m<sup>3</sup>/sec (1,470 cfs).

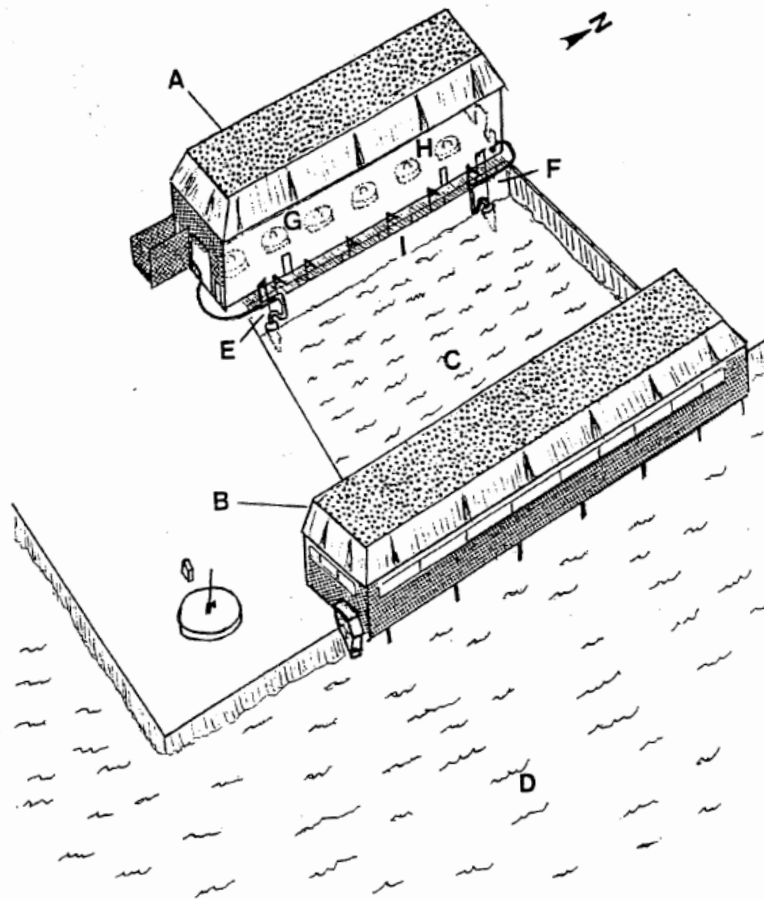


Figure 2. Schemata of the Belle River Power Plant showing sampling stations and other pertinent information.  
 A = Pump house    B = Screen house    C = Forebay    D = St. Clair River  
 E = Unit #1 (south)    F = Unit #2 (north)    G = Unit #1 Circulation Pumps (3)  
 H = Unit #2 Circulation Pumps (3)    I = Catwalk with POC sampling stations

**Figure 2-8**  
**Schematic diagram of the Belle River Power Plant sampling stations (Freshwater Physicians, Inc. 1991)**

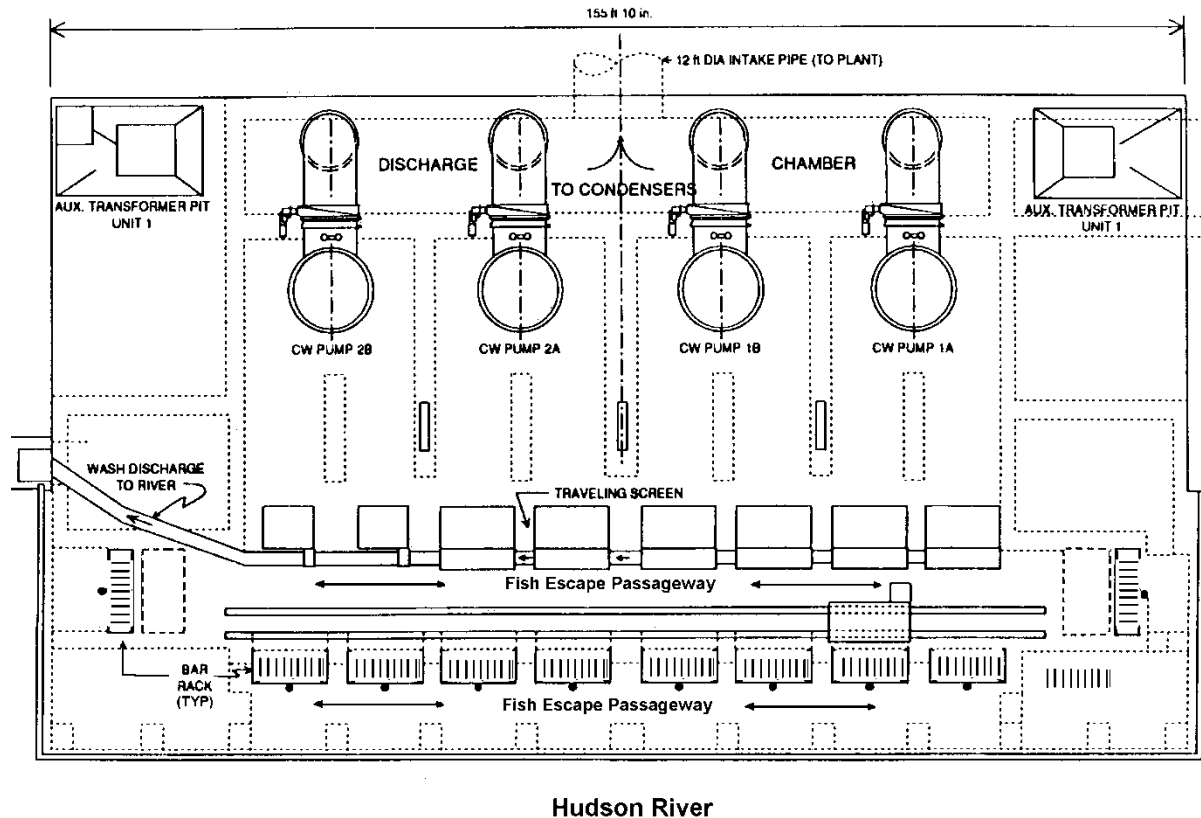
Impinged fish were collected by diverting the screen washwater from the fish and debris trough into a steel collection box. The fish were removed from the box using a 6-mm (0.2 in.) mesh net. The collected fish were sorted, identified (if possible), and classified by condition. A total of 679 fish representing 33 species were collected during the 12-month impingement sampling period. Most of the fish impinged were small (<100 mm [3.9 in.]). Impingement rates were highest in May and October and lowest in summer. Alewife (*Alosa pseudoharengus*) were collected only 17 weeks out of the 12-month sampling period; however, they were the third most abundant species collected. Alewife were generally impinged in great numbers, or not at all, and their presence or absence had a marked effect on weekly impingement numbers. The initial survival rates of impinged fish were generally high. The authors suggest that the survival rates were underestimated due the fact that fish washed from the traveling screens were often retained in the collection net for periods of up to 24 hrs before the net was emptied, thus subjecting them to additional stress from high flows, abrasion, and debris while in the net. None of the *Alosa*

spp. (alewife and gizzard shad [*Dorosoma cepedianum*]) were ever recovered from the net alive, however, groups of darters, centrarchids, sculpins (Cottidae), and catfish exhibited survival rates over 60%.

### **Roseton Generating Station**

Two modified dual-flow (double entry/single exit) screens were installed at Central Hudson Gas and Electric Corporation's (CHGE) Roseton Generating Station (LMS 1991). The dual-flow screens were installed as replacements for two of the eight conventional band-type vertical traveling screens in March 1990, primarily to improve debris-handling capabilities at the station. The sealed system of the dual-flow screen is designed to eliminate debris carryover. The dual-flow screens were designed to include characteristics in design and operation that may increase fish survival, including water retaining lifting buckets, a dual-pressure spray cleaning system, flattened woven wire mesh, and faster operational speeds. Evaluations were conducted to monitor the initial and extended survival of aquatic organisms in terms of screen type, biological population characteristics, physical-chemical environmental conditions, and plant operational parameters.

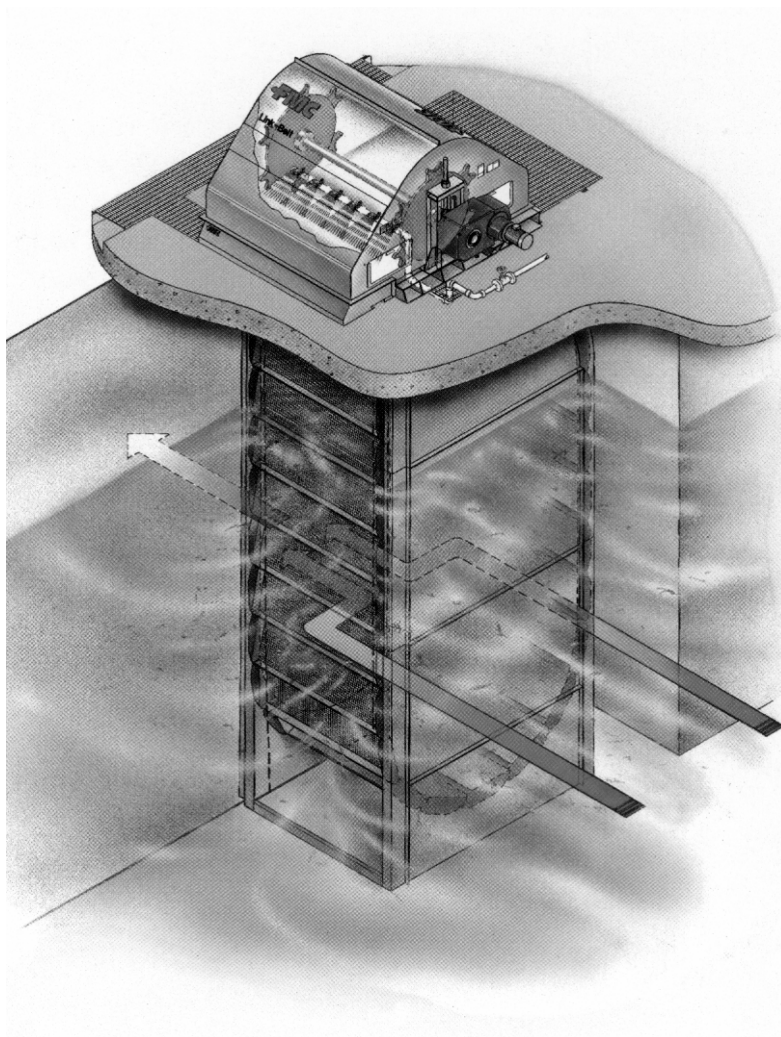
Roseton Generating Station is a steam electric power plant with a maximum generating capacity of 1,200 MW. The station's once-through cooling water system contains four pumps with a combined capacity of 40.4 m<sup>3</sup>/sec (1,426 cfs). Water enters the shoreline intake system from the Hudson River through an array of 16 intake portals, 12 on the front of the intake structure and two on each end. The upper perimeter of the intake structure over the portal area is surrounded by a skimmer wall that extends to a depth of 1.7m (5.4 ft) below extreme low water. The wall prevents large debris and ice from clogging the trash racks. Ten vertical trash racks with center-to-center spacing of 76.2 mm (3.0 in.) are located between the portals and the traveling screens. A fish escape passageway exists between the trash racks and the traveling screens: The intake design allows fish to enter through the front trash racks and move laterally along the flush-mounted traveling screens, where they can escape out through the side trash racks (Figure 2-9).



**Figure 2-9**  
**Plan view of Roseton cooling water intake structure (modified from LMS 1991)**

The screen array consists of six conventional vertical traveling screens and two dual-flow traveling screens. A schematic of a dual-flow screen appears on Figure 2-10. Velocities approaching the conventional traveling screens are 0.23 m/sec (0.75 ft/sec), with two pumps operating (King et al. 1978). The conventional traveling screens are fitted with 9.5 mm (3/8 in) polyvinyl chloride (PVC) square mesh. Each of the conventional screens are 12.8 m (42 ft) high and 3.0 m (9.7 ft) wide and rotate at 3.1 m (10 ft) per min, making one complete revolution every 8.9 min. A front wash spray cleaning system is employed on the conventional screens. The screen washings drain into a disposal trough and are returned to the Hudson River.

The two dual-flow screens (Figure 2-11) are 14.9 m (49 ft) high and fitted with 3.2 by 12.7-mm (1/8 by 1/2-in.) stainless steel woven wire mesh. Each screen basket measures 1.2 by 0.46 m (4.0 by 1.5 ft) and is fitted with a water retaining trough with an inward curved leading edge. The dual-flow screens are operated at a travel speed of 3.0 m/min (10 ft/min) and employ a “backwash” spray cleaning system. The system uses both low (organism removal) and high-pressure (debris removal) sprays for screen cleaning. The low-pressure unit is located on the top of the unit where the baskets go over the drive sprocket. Spray discharge is 5, 10, and 15 psi for each of the low-pressure nozzles. The high-pressure cleaning system sprays water through the screen panels just above deck level. Discharge pressure for each of the high-pressure nozzles is 70, 80, and 90 psi.



**Figure 2-10**  
**Schematic of a dual-flow traveling intake screen (courtesy of U.S. Filter)**

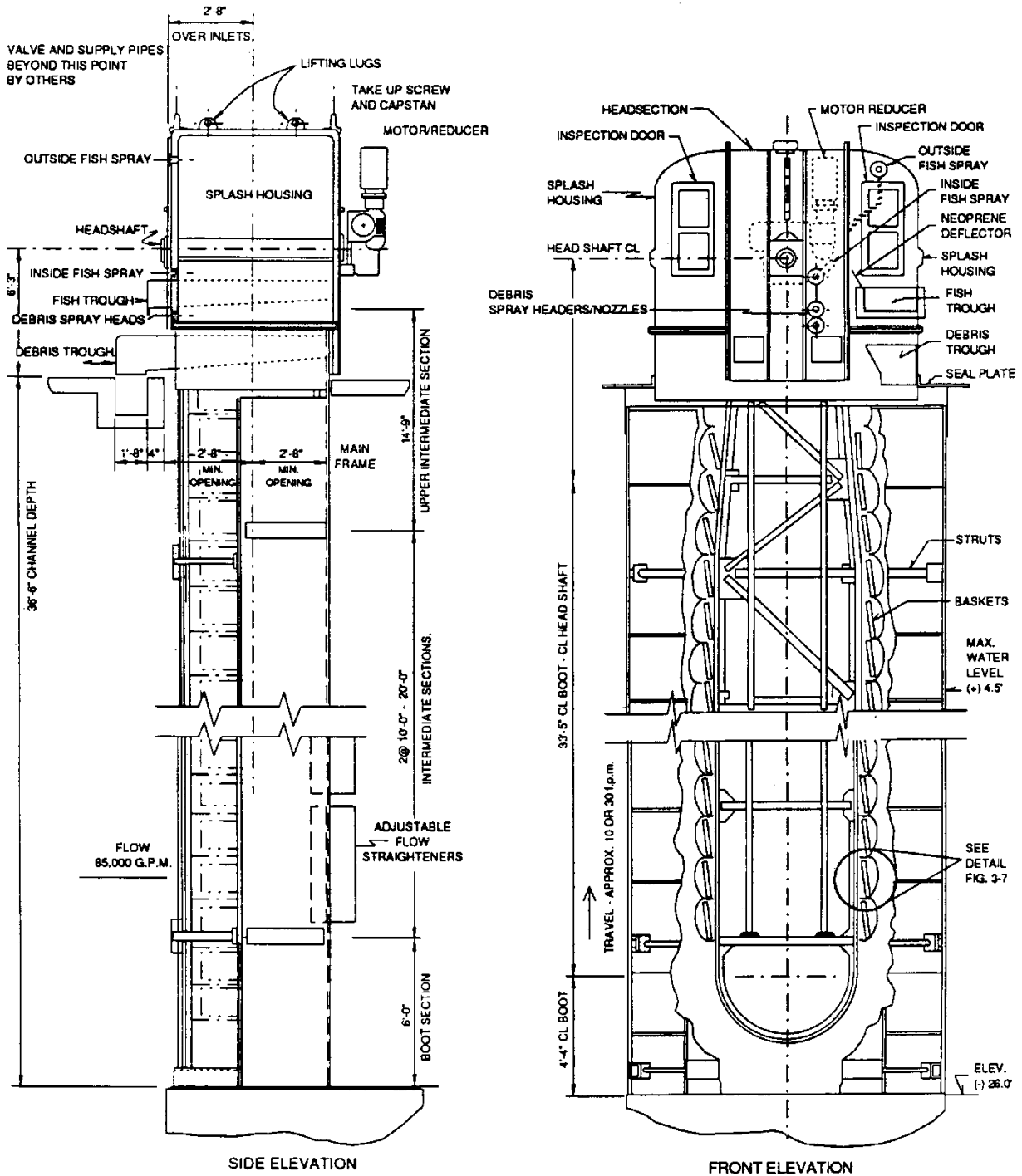


Figure 2-11  
Section view of Roseton dual-flow traveling screen (LMS 1991)

The Roseton intake screen evaluation required the use of two collecting devices to sample fish from low- and high-pressure wash water of the dual-flow screens and the high-pressure wash water from conventional screens.

The post-impingement survival program was conducted during two seasonal periods: May 9 through August 30, and September 30 through November 29, 1990. A total of 569 paired samples were collected during the May–August period, and 246 paired samples were collected during the October–November period, for a total of 815 paired samples. Collected samples were transported to CHGE’s Danskammer Point Laboratory for processing. Fish were classified as live (swimming normally, no orientation problem), stunned (swimming erratically, swimming on their side, struggling), or dead (no vital life signs, no body or opercular movement, no response to gentle probing). All live and stunned fish were separated from debris and blue crabs and held in containers with river water for extended (48-hr) survival observations. Final determination of fish condition occurred 96 hrs after the initiation of the extended survival observations. All fish held for extended survival observations were measured for total length and weighed.

A mark-recapture study was conducted during the dual-flow screen evaluation to obtain information on the efficiency of the low-pressure screen wash system and to determine the amount of stress associated with the collection and handling of organisms. Additionally, water quality parameters (water temperature, specific conductance, and dissolved oxygen) were monitored to determine their impacts on fish survival during testing. Collection and handling mortality was determined for the conventional screens by accounting for holding facility, marking, and collection tank mortality. For the dual-flow screens, collection and handling mortality was determined by the influence of the holding facility, marking, collection tank, and lip trough introduction. Based on the results of the collection and handling study, post-impingement survival was not adjusted for either screen type. Water temperature, however, was found to be the primary variable influencing initial survival following impingement on either of the screen types. Initial survival was 42% for specimens collected at 8 to 10°C (46 to 50°F) and increased to 90% at 12°C (54°F). Initial survival steadily decreased to a low of 6% at the highest temperature range (22 to 26°C [72 to 79°F]).

The initial condition of fish was recorded immediately after impingement on the traveling screens. The dual-flow screens collected 48,729 fish representing 30 species, and the conventional traveling screens collected 13,623 fish representing 29 species (Table 2-16). A total of 12,668 fish representing 29 species were evaluated for extended survival after being collected from the dual-flow screens. A total 4,024 fish representing 22 species collected from the conventional traveling screens were evaluated for extended survival.

For the dominant taxonomic groups, screen type was not found to be the most important factor influencing survival. In eight circumstances, screen type was identified as a significant influence but only as a second order effect. Post-impingement survival recorded for the two dual-flow screens was higher than the post-impingement survival recorded for the conventional traveling screens but was not determined to be significantly higher. Season and screen type appeared to have almost no impact on survival for fragile fish species (Table 2-16). Blueback herring (*Alosa aestivalis*), bay anchovy (*Anchoa mitchilli*), alewife (*Alosa pseudoharengus*), and American shad (*Alosa sapidissima*) made up nearly 80% of the total catch and had a combined post-impingement survival of less than 1%.



**Table 2-16**  
**Seasonal post-impingement survival Roseton Generating Station (LMS 1991)**

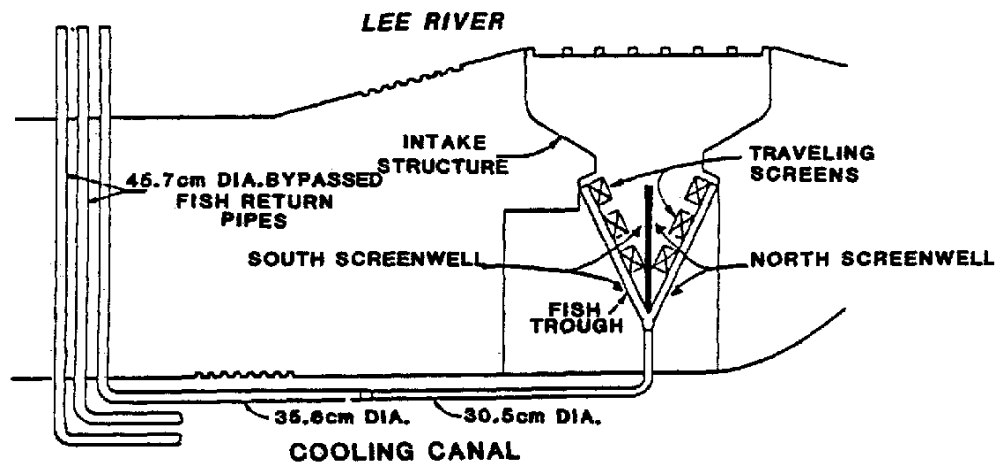
| Species                               | Spring-Summer (9 May –30 August) |                         |                           |                | Fall (30 September–27 November) |                         |                           |                |
|---------------------------------------|----------------------------------|-------------------------|---------------------------|----------------|---------------------------------|-------------------------|---------------------------|----------------|
|                                       | Number Collected (N)             | % Initial Survival (SI) | % Extended Survival (S96) | % Survival (S) | Number Collected (N)            | % Initial Survival (SI) | % Extended Survival (S96) | % Survival (S) |
| <b>Dual-Flow Traveling Screen</b>     |                                  |                         |                           |                |                                 |                         |                           |                |
| blueback herring                      | 17,719                           | 3.8                     | 0.0                       | 0.0            | 10,625                          | 24.0                    | 0.6                       | 0.1            |
| white perch                           | 2,691                            | 74.9                    | 43.7                      | 32.7           | 2,539                           | 79.9                    | 59.6                      | 47.6           |
| bay anchovy                           | 3,098                            | 1.0                     | 0.0                       | 0.0            | 2,063                           | 1.5                     | 0.0                       | 0.0            |
| American shad                         | 2,460                            | 8.0                     | 6.0                       | 0.5            | 70                              | 41.4                    | 0.0                       | 0.0            |
| alewife                               | 2,402                            | 6.5                     | 4.4                       | 0.3            | 118                             | 57.6                    | 0.0                       | 0.0            |
| striped bass                          | 2,073                            | 81.6                    | 52.6                      | 42.9           | 77                              | 80.5                    | 38.6                      | 31.1           |
| gizzard shad                          | 470                              | 20.2                    | 60.7                      | 12.1           | 276                             | 88.8                    | 26.6                      | 23.6           |
| spottail shiner                       | 157                              | 68.2                    | 67.3                      | 45.9           | 404                             | 96.3                    | 77.0                      | 74.2           |
| brown bullhead                        | 332                              | 98.5                    | 84.1                      | 82.8           | 28                              | 96.4                    | 92.9                      | 89.6           |
| hogchoker                             | 232                              | 99.6                    | 96.1                      | 95.7           | 112                             | 100.0                   | 98.2                      | 98.2           |
| <b>Conventional Traveling Screens</b> |                                  |                         |                           |                |                                 |                         |                           |                |
| blueback herring                      | 2,880                            | 2.3                     | 0.0                       | 0.0            | 3,426                           | 23.3                    | 0.2                       | <0.1           |
| white perch                           | 925                              | 49.1                    | 18.0                      | 8.8            | 1,438                           | 68.7                    | 48.4                      | 33.3           |
| bay anchovy                           | 1,667                            | 0.1                     | 0.0                       | 0.0            | 409                             | 0.0                     | 0.0                       | 0.0            |
| American shad                         | 546                              | 2.6                     | 7.1                       | 0.2            | 66                              | 36.4                    | 0.0                       | 0.0            |
| alewife                               | 637                              | 01.6                    | 7.7                       | 0.1            | 99                              | 36.4                    | 0.0                       | 0.0            |
| striped bass                          | 268                              | 64.2                    | 37.1                      | 23.8           | 39                              | 59.0                    | 28.6                      | 16.9           |
| gizzard shad                          | 23                               | 13.0                    | 0.0                       | 0.0            | 216                             | 66.7                    | 8.1                       | 5.4            |
| spottail shiner                       | 27                               | 37.0                    | 41.7                      | 13.5           | 150                             | 65.3                    | 79.4                      | 51.8           |
| brown bullhead                        | 158                              | 91.1                    | 67.1                      | 61.1           | 6                               | 100.0                   | 100.0                     | 100.0          |
| hogchoker                             | 266                              | 98.9                    | 92.4                      | 91.4           | 60                              | 96.7                    | 93.5                      | 90.4           |

## Brayton Point Station

Biological evaluations were conducted to determine the number, species, and initial and extended survival of fish impinged on the modified intake screens at Brayton Point Station Unit 4 (Davis et al. 1988; LMS 1987). These fine-mesh, angled screens were installed at a new Unit 4 intake to divert larger, motile life stages and gently collect and recover early life stages. We discuss the results of collection survival studies below. We discuss additional studies conducted to determine the diversion efficiency of the angled screens elsewhere in this report.

The station is located on the Lee River north of the confluence with the Taunton River on Mount Hope Bay, Massachusetts. The facility is comprised of four units with a total generating capacity rated at 1,590 MW. Unit 4 has total rated capacity of 460 MW.

The new intake structure has eight openings 3.3 by 4.2 m (11 by 14 ft) high that extend to the bottom of a skimmer wall. Trash racks with bar spacing of 7.5 cm (3 in.) on center cover the intake openings. Approximately 10 m (33 ft) downstream of the trash racks, the width of the screenwell constricts to 12.3 m (41 ft). A center wall divides the structure in half, and each half is equipped with three 3.0-m wide (10 ft) flush-mounted modified vertical traveling screens. The screens are set at a 25 degree angle to the flow and lead to a fish bypass. Each screen panel is modified with a fish-lifting bucket and is capable of interchanging standard 9.5-mm (3/8-in.) screen and 1.0 mm (0.04 in.) fine-mesh screen. The design flow of the intake is 17.28 m<sup>3</sup>/s (610 cfs), which results in an average screen approach velocity of 0.30 m/sec (1.0 ft/sec). Nearly 97% of the design flow is drawn through the screens; the remaining 3% is pumped through a fish bypass (Figure 2-12).



**Figure 2-12**  
**Brayton Point angled traveling screen intake configuration (Davis et al. 1988)**

The fish bypass is a rectangular opening 15.2 cm by 5.1 m (6 in. by 17 ft) located at the apex of each screenwell. The bypass leads into a 46 cm (18 in.) diameter bypass pipe. Two shrouded 30 cm (12 in.) diameter screw impeller centrifugal pumps can induce a velocity of 0.3 m/sec (1 ft/sec) at the bypass entrance. The bypass pipes discharge to the Lee River. Fish that do not

enter the bypass and become impinged on the traveling screens are removed by a low-pressure backwash system and via a fish sluice back to the Lee River in the same location as the bypass return (Figure 2-12).

Survival and impingement abundance sampling were conducted simultaneously with bypass survival and abundance collections. Complete diel periods were covered during weekly collections. Two, 1.5 m (5 ft) fiberglass collection tanks were used to receive the screen washings from the six angled screens (one tank per three screens). Bypass subsample collections were made using nets attached to sampling ports on each of the 46 cm (18 in.) return lines. Fish collected from the bypass flow and the screenwash were classified by condition and placed in separate holding tanks for extended (48-hr) survival observations.

A total of 18,831 fish collected from the fine-mesh traveling screens were used to evaluate initial and 48-hr survival. The lowest survival was calculated for bay anchovy (*Anchoa mitchilli*) and the highest was for tautog (*Tautoga onitis*) (Table 2-17).

Trends in survival appeared to be affected by species. Initial and extended survival varied by species, however, a certain group of numerically dominant taxa was classified by the authors as “fragile” (primarily, bay anchovy and Atlantic silverside). The fragile group had a calculated survival below 25.0% and a “hardy” group, dominated by winter flounder (*Pseudopleuronectes americanus*) and Northern pipefish (*Syngnathus fuscus*), had survival values greater than 65.0%.

**Table 2-17**  
**Impingement survival information — Brayton Point Station Unit 4 (Oct. 1984–March 1986) (Davis et al. 1988)**

| Taxon                  | Initial Survival   |      | Extended Survival<br>48 Hr |      | Total<br>Impingement<br>Survival (%) |
|------------------------|--------------------|------|----------------------------|------|--------------------------------------|
|                        | Number<br>Analyzed | (%)  | Number<br>Analyzed         | (%)  |                                      |
| bay anchovy            | 13,987             | 1.7  | 235                        | 1.7  | <0.1                                 |
| Atlantic silverside    | 745                | 82.1 | 491                        | 22.2 | 18.2                                 |
| winter flounder        | 1,025              | 95.6 | 787                        | 95.2 | 91.0                                 |
| Northern pipefish      | 1,551              | 98.1 | 1,134                      | 95.1 | 93.3                                 |
| threespine stickleback | 113                | 93.8 | 105                        | 96.2 | 90.2                                 |
| Atlantic menhaden      | 126                | 38.1 | 48                         | 8.3  | 3.2                                  |
| fourspine stickleback  | 183                | 86.9 | 155                        | 96.1 | 83.5                                 |
| tautog                 | 329                | 97.9 | 317                        | 98.4 | 96.3                                 |
| American eel           | 5                  | 60.0 | 0                          | --   | --                                   |
| butterfish             | 37                 | 56.8 | 21                         | 57.1 | 32.4                                 |
| hogchoker              | 117                | 99.1 | 115                        | 96.5 | 95.6                                 |
| seaboard goby          | 126                | 87.3 | 109                        | 85.3 | 74.5                                 |

### **Prairie Island Generating Plant**

A 5-year study was conducted to assess the effectiveness of fine-mesh (0.5 mm [0.02 in.]) vertical traveling screens in reducing fish losses at Prairie Island Generating Plant (Kuhl and Mueller 1988). The Prairie Island Plant is located on the West bank of the Mississippi River approximately 40 miles (64.4 km) southeast of Minneapolis/St. Paul, Minnesota. The plant consists of two 560 MW units. The plant is capable of operating its circulating water system as a once-through system, a closed-loop system, or a helper system (a portion of the cooling water is recycled). Maximum plant flow is approximately 42.5 m<sup>3</sup>/sec (1,500 cfs).

Samples were collected on Monday, Wednesday, and Friday of each week from April 8 to August 31, 1988. Twenty-five percent of the screen wash water (two out of the eight screens) was diverted from the screen wash trough into collection tanks. The collection tank filters screen wash water through 0.5-mm (0.02-in.) mesh nylon screen material. During sampling, the fine-mesh screens were operated in the automatic mode with rotational speeds ranging from 0.9 to 3 m/min (3 to 10 ft/min).

Initial survival samples were collected during early morning (before daylight) and underwent two sorting procedures. The first sort was performed to quickly separate live fish from dead fish, while the second sort was performed to make certain that all the remaining fish and eggs were removed from the sample. Initial and latent survival was calculated by species, lifestage, and year for the representative important species. The numbers of each fish collected and their survival rates varied by life stage and species. The highest overall survival rate was exhibited by walleye (*Sander vitreus*) postlarvae, while postlarval gizzard shad (*Dorosoma cepedianum*) had a survival rate of less than 0.1% (Table 2-18). In general, juvenile fish tended to exhibit higher survival rates than prolarvae and postlarvae. Channel catfish (*Ictalurus punctatus*) and walleye had high survival for the life stages collected, unlike freshwater drum (*Aplodinotus grunniens*), gizzard shad (*Dorosoma cepedianum*), and white bass (*Morone chrysops*), which showed relatively poor survival regardless of life stage.

**Table 2-18**  
**Initial, latent, and overall survival by taxa and lifestage for 1984–1987 Prairie Island Generating Plant (Kuhl and Mueller 1988)**

| Species Name        | Lifestage  | Initial Survival |       |              | Latent Survival |       |              | Overall Survival |
|---------------------|------------|------------------|-------|--------------|-----------------|-------|--------------|------------------|
|                     |            | Dead             | Live  | Percent Live | Dead            | Live  | Percent Live | Percent Live     |
| gizzard shad        | postlarvae | 2,899            | 23    | 0.8          | 55              | 1     | 1.8          | <0.1             |
| gizzard shad        | juvenile   | 17               | 8     | 32.0         | 13              | 1     | 7.1          | 2.3              |
| mooneye             | prolarvae  | 39               | 12    | 23.5         | 25              | 4     | 13.8         | 3.2              |
| carp                | prolarvae  | 1,778            | 881   | 33.1         | 182             | 458   | 71.6         | 23.7             |
| carp                | postlarvae | 1,570            | 296   | 15.9         | 331             | 1,638 | 83.2         | 13.2             |
| carp                | juvenile   | 4                | 95    | 96.0         | 40              | 112   | 73.7         | 70.7             |
| Cyprinidae          | prolarvae  | 2,622            | 8     | 0.3          | 17              | 10    | 37.0         | 0.1              |
| Cyprinidae          | postlarvae | 13,690           | 391   | 2.8          | 276             | 339   | 55.1         | 1.5              |
| Cyprinidae          | juvenile   | 454              | 1,306 | 74.2         | 719             | 1,179 | 62.1         | 46.1             |
| Cyprinidae          | adult      | 0                | 8     | 100.0        | 13              | 8     | 38.1         | 38.1             |
| Catostomidae        | prolarvae  | 935              | 1,088 | 53.8         | 301             | 1,296 | 81.2         | 43.6             |
| Catostomidae        | postlarvae | 146              | 103   | 41.4         | 107             | 687   | 86.5         | 35.8             |
| Catostomidae        | juvenile   | 9                | 25    | 73.5         | 7               | 50    | 87.7         | 64.5             |
| channel catfish     | prolarvae  | 81               | 224   | 73.4         | 6               | 24    | 80.0         | 58.8             |
| channel catfish     | juvenile   | 2,535            | 5,765 | 69.5         | 556             | 2,653 | 82.7         | 57.4             |
| trout perch         | juvenile   | 3                | 34    | 91.9         | 35              | 58    | 62.4         | 57.3             |
| white bass          | prolarvae  | 76               | 0     | 0.0          | 8               | 0     | 0.0          | 0.0              |
| white bass          | postlarvae | 1,227            | 155   | 11.2         | 513             | 122   | 19.2         | 2.2              |
| white bass          | juvenile   | 26               | 67    | 72.0         | 90              | 67    | 42.7         | 30.7             |
| <i>Lepomis</i> spp. | postlarvae | 215              | 10    | 4.4          | 23              | 7     | 23.3         | 1.0              |
| <i>Lepomis</i> spp. | juvenile   | 13               | 52    | 80.0         | 14              | 80    | 85.1         | 68.1             |
| <i>Pomoxis</i> spp. | postlarvae | 177              | 9     | 4.8          | 17              | 18    | 51.4         | 2.5              |
| <i>Pomoxis</i> spp. | juvenile   | 2                | 30    | 93.8         | 36              | 52    | 59.1         | 55.4             |
| sauger              | prolarvae  | 51               | 17    | 25.0         | 14              | 40    | 74.1         | 18.5             |
| sauger              | postlarvae | 44               | 17    | 27.9         | 10              | 9     | 47.4         | 13.2             |
| walleye             | prolarvae  | 15               | 104   | 87.4         | 123             | 456   | 78.8         | 68.8             |
| walleye             | postlarvae | 0                | 2     | 100.0        | 3               | 15    | 83.3         | 83.3             |
| Percidae            | prolarvae  | 362              | 33    | 8.4          | 24              | 34    | 58.6         | 4.9              |
| Percidae            | postlarvae | 273              | 38    | 12.2         | 167             | 42    | 20.1         | 2.5              |
| Percidae            | juvenile   | 19               | 40    | 67.8         | 26              | 90    | 77.6         | 52.6             |
| freshwater drum     | prolarvae  | 20,134           | 414   | 2.0          | 751             | 159   | 17.5         | 0.4              |
| freshwater drum     | postlarvae | 3,340            | 693   | 17.2         | 1,145           | 447   | 28.1         | 4.8              |
| freshwater drum     | juvenile   | 190              | 433   | 69.5         | 420             | 401   | 48.8         | 33.9             |

## Big Bend Station

In 1980, Tampa Electric Company (TECO) performed a pilot scale evaluation of a fine-mesh Ristroph screen in the intake canal to its Big Bend Station on Tampa Bay, Florida (Taft et al. 1981a; Brueggemeyer et al. 1988). At the time, the station consisted of three generating units with a combined once-through flow rate of 45.6 m<sup>3</sup>/s (1,611 cfs). TECO planned to add a fourth generating unit. Region IV of the USEPA and the Florida Department of Environmental Regulation expressed concern for the losses of organisms due to the operation of the station with the additional unit. Accordingly, TECO agreed to evaluate the potential effectiveness of fine-mesh screens to reduce losses of the selected Representative Important Species (RIS): bay anchovy (*Anchoa mitchilli*), black drum (*Pogonias cromis*), silver perch (*Bairdiella chrysoura*), spotted seatrout (*Cynoscion nebulosus*), scaled sardine (*Harengula jaguana*), tidewater silverside (*Menidia peninsulae*), stone crab (*Menippe mercenaria*), pink shrimp (*Penaeus duorarum*), American oyster (*Crassostrea virginica*), and blue crab (*Callinectes sapidus*). In 1980, an extensive biological evaluation of a full-scale, prototype screen was conducted. The test facility was located immediately upstream of the existing Unit 1–3 intake screens. The screen was of the no-well design, similar to the existing screens (Figure 2-13).

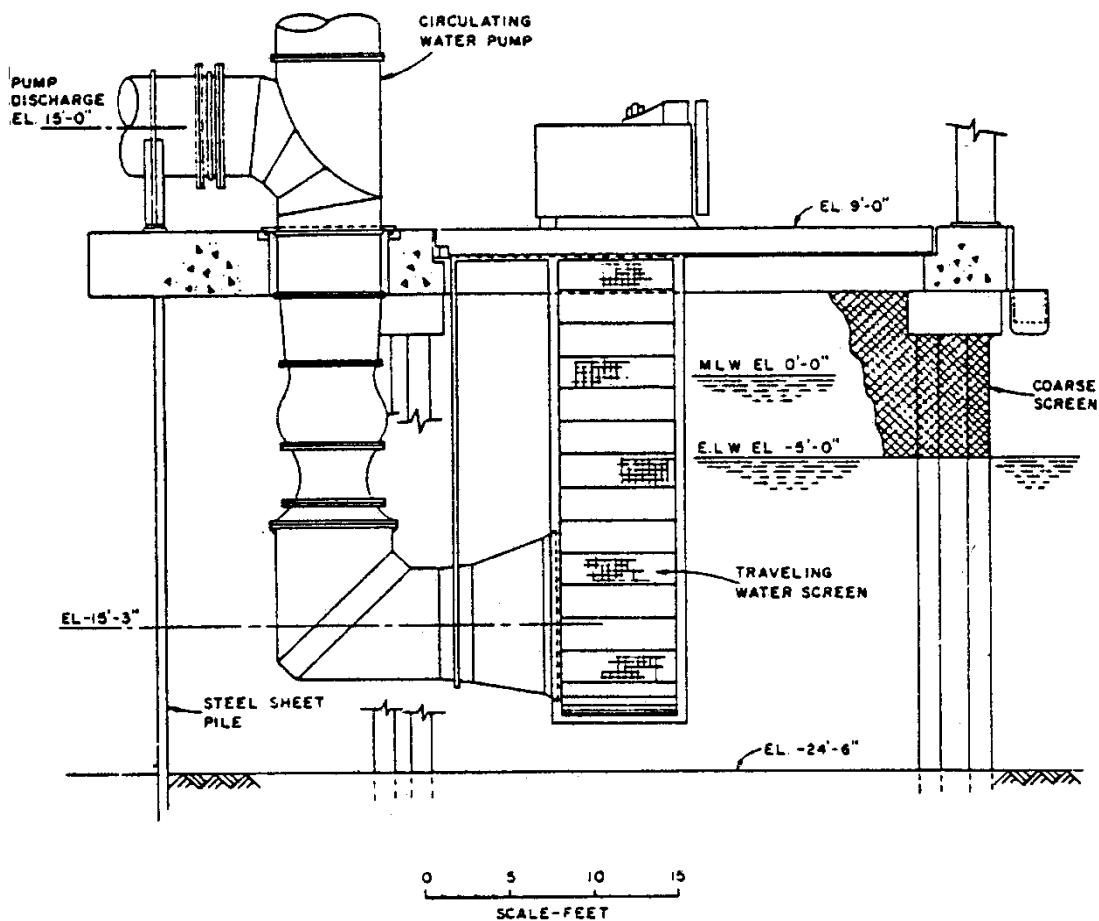


Figure 2-13  
No-well screen (SWEC 1980)

The screen was full-depth, comprised of 48 screen baskets which were 0.6 by 0.6m (2 by 2 ft) high with 0.5-mm (0.02-in.) screen mesh. The screen could be rotated at speeds from 2.1 to 8.5 m/min (6.9 to 27.9 ft/min). A variable speed pump permitted testing at screen approach velocities ranging from 0.15 to 0.31 m/sec (0.5 to 1.0 ft/sec). Organisms were washed from the ascending face of the screens and lifting buckets into a collection trough with a low-pressure (10 psi) spraywash. Once in the trough, the organisms flowed by gravity into a primary collection tank from which they were drained into a secondary chamber, which also served as the container in which the organisms were transported to the onsite wet laboratory.

The organism survival study consisted of a series of tests conducted at six combinations of approach velocities (15.2 and 30.5 cm/sec [0.5 and 1.0 ft/sec]) and screen rotational speed (2.1, 4.3, and 8.5 m/min [6.9, 14.1 and 27.9 ft/min]). Control organisms were collected from the intake canal using a stationary 505  $\mu$ m plankton net. All organisms were held for 96 hrs following collection to determine latent effects. Results of testing are presented in Table 2-19 through Table 2-22. An analysis of the data indicated that, while temperature and approach velocity had significant effects on initial survival, hatchability, and latent survival of Sciaenidae eggs and larvae, the hatchability and survival differences were not large and explained little of the observed variability in the dependent variable, survival. Therefore, the data in Table 2-19 through Table 2-22 are considered good indicators of the performance of the fine-mesh screen (Taft et al. 1981a).

**Table 2-19**  
**Fish eggs — percent survival and hatchability Big Bend Plant (Taft et al. 1981a)**

| Taxa                     | Initial Survival (%) |         | Hatchability (%) |         | 48-Hr Survival (%) |         | 96-Hr Survival (%) |         |
|--------------------------|----------------------|---------|------------------|---------|--------------------|---------|--------------------|---------|
|                          | Test                 | Control | Test             | Control | Test               | Control | Test               | Control |
| <i>Sciaenidae</i>        | 75.3                 | 98.4    | 94.8             | 99.0    | 84.3               | 91.3    | 69.7               | 82.7    |
| silver perch             | 100.0                | 100.0   | 100.0            | 100.0   | 99.1               | 99.4    | 97.9               | 97.8    |
| <i>Cynoscion spp.</i>    | 100.0                | 100.0   | 100.0            | 100.0   | 99.4               | 99.3    | 89.4               | 96.9    |
| <i>Menticirrhus spp.</i> | 100.0                | 100.0   | 100.0            | 100.0   | 99.7               | 100.0   | 88.4               | 91.5    |
| black drum               | 100.0                | --      | 100.0            | --      | 82.2               | --      | 85.3               | --      |
| <i>Alosa spp.</i>        | 43.2                 | 85.5    | 81.0             | 89.3    | 84.4               | 90.3    | 62.4               | 68.6    |
| scaled sardine           | 45.8                 | 99.6    | 92.9             | 98.5    | 82.8               | 92.2    | 45.9               | 27.6    |
| bay anchovy              | 43.3                 | 85.0    | 80.0             | 88.6    | 83.9               | 90.0    | 63.7               | 72.0    |

Note: Dashes indicate no observations.



**Table 2-20**  
**Fish larvae — percent initial and latent survival at Big Bend (Taft et al. 1981a)**

| Taxa                     | Initial Survival (%) |           | 48-Hr Survival (%) |         | 96-Hr Survival (%) |         |
|--------------------------|----------------------|-----------|--------------------|---------|--------------------|---------|
|                          | Test                 | Control   | Test               | Control | Test               | Control |
| Sciaenidae               | 18.6 (108)           | 44.4 (6)  | 10.9 (26)          | 0.0 (1) | 10.1 (26)          | 0.0 (1) |
| silver perch             | 19.2 (39)            | 50.0 (2)  | --                 | --      | --                 | --      |
| <i>Cynoscion spp.</i>    | 15.7 (51)            | 0.0 (1)   | 100 (3)            | --      | 100.0 (3)          | --      |
| <i>Menticirrhus spp.</i> | 0.0 (15)             | 25.0 (4)  | --                 | --      | --                 | --      |
| black drum               | 42.9 (7)             | 100.0(1)  | --                 | --      | --                 | --      |
| <i>Alosa spp.</i>        | 1.5 (278)            | 10.4 (11) | 36.4 (11)          | 0.0 (1) | 36.4 (11)          | 0.0 (1) |
| scaled sardine           | 0.0 (15)             | --        | --                 | --      | --                 | --      |
| bay anchovy              | 1.5 (274)            | 11.4 (10) | 22.2 (9)           | 0.0 (1) | 22.2 (9)           | 0.0 (1) |

Notes: Number of observations is given in parentheses.  
Dashes indicate no observations.

**Table 2-21**  
**Decapod zoea — percent initial and latent survival at Big Bend (Taft et al. 1981a)**

| Taxa                      | Initial Survival (%) |         | 48-Hr Survival (%) |         | 96-Hr Survival (%) |         |
|---------------------------|----------------------|---------|--------------------|---------|--------------------|---------|
|                           | Test                 | Control | Test               | Control | Test               | Control |
| Caridea                   | 94.3                 | 76.7    | 85.0               | 86.8    | 50.0               | 43.8    |
| <i>Upogebia affinis</i>   | 91.3                 | 75.6    | 84.1               | 76.2    | 42.8               | 45.4    |
| Brachyura                 | 95.5                 | 65.0    | 83.9               | 55.6    | 45.9               | 27.8    |
| Grapsizoea                | 100.0                | 100.0   | 95.1               | 97.9    | 80.2               | 92.9    |
| Pinnotheridae             | 100.0                | 100.0   | 92.2               | 93.4    | 73.0               | 72.1    |
| Xanthidae                 | 99.1                 | --      | 95.9               | 95.6    | 74.9               | 73.4    |
| <i>Menippe mercenaria</i> | 97.9                 | 97.3    | 91.5               | 94.9    | 58.3               | 61.0    |
| Paguridae                 | 94.7                 | 100.0   | 96.6               | 100.0   | 79.2               | 33.3    |

Note: Dashes indicate no observations.

**Table 2-22**  
**Decapod megalops — percent initial and latent survival at Big Bend (Taft et al. 1981a)**

| Taxa               | Initial Survival (%) |         | 48-Hr Survival (%) |         | 96-Hr Survival (%) |         |
|--------------------|----------------------|---------|--------------------|---------|--------------------|---------|
|                    | Test                 | Control | Test               | Control | Test               | Control |
| Caridea            | 100.0                | --      | 100.0              | --      | 100.0              | --      |
| Upogebia affinis   | 100.0                | 100.0   | 97.7               | 100.0   | 74.3               | 100.0   |
| Brachyura          | 65.1                 | 26.7    | 71.8               | --      | 15.0               | --      |
| Grapsizoea         | 100.0                | 100.0   | 98.1               | 100.0   | 93.1               | 91.2    |
| Pinnotheridae      | 100.0                | --      | 100.0              | --      | 92.9               | --      |
| Xanthidae          | 100.0                | 100.0   | 98.3               | 100.0   | 94.2               | 96.9    |
| Menippe mercenaria | 100.0                | --      | 100.0              | --      | 100.0              | --      |
| Paguridae          | 100.0                | --      | 90.0               | --      | 80.0               | --      |

Note: Dashes indicate no observations.

Based on the positive results of the prototype testing, the regulatory agencies determined that Unit 4 could be constructed with a once-through condenser cooling system provided that fine-mesh screens were incorporated into the intake structures of both Units 3 and 4. Accordingly, six, 0.5 mm (0.02 in.) No-well screens were installed at the station, and studies of their biological effectiveness were conducted in 1985 (Brueggemeyer et al. 1988).

The fish return system required the incorporation of three WEMCO Hidrostral pumps to provide the energy needed to transport collected organisms to a remote discharge location. The pumps are located in a sump that collects the combined screenwash discharge from all six screens. To account for possible pump effects on organism survival, samples were collected both from the sump and at the remote organism return discharge (ORD). Control organisms were collected from the intake canal upstream of the screens. Sampling and holding methods were similar to those used in the prototype study.

We present results of the full-scale biological evaluation in Table 2-23 and Table 2-24. The conclusion of the study was that survival rates were comparable to, and in some cases exceeded, those obtained during the prototype study. There was no significant difference in survival rates between the two sample locations.

**Table 2-23**  
**Comparison of initial survival (%) during the FMS survivability studies at Big Bend Station**  
**(Brueggemeyer et al. 1988)**

| Taxa           | Initial Survival (%) |     |         |
|----------------|----------------------|-----|---------|
|                | Screenwash           | ORD | Control |
| Fish Eggs:     |                      |     |         |
| bay anchovy    | 48                   | 29  | 72      |
| Sciaenidae     | 63                   | 40  | 72      |
| Fish Larvae:   |                      |     |         |
| bay anchovy    | 16                   | 58  | 16      |
| Sciaenidae     | 61                   | 56  | 85      |
| Invertebrates: |                      |     |         |
| Caridea        | 72                   | 70  | 65      |
| Xanthidae      | 93                   | 90  | 88      |
| Pinnotheridae  | 99                   | 83  | 77      |

**Table 2-24**  
**Comparison of fish egg hatchability and latent 48 hr survival (%) during the prototype and FMS**  
**survivability studies (Brueggemeyer et al. 1988)**

| Taxa           | Screenwash                | ORD | Control |
|----------------|---------------------------|-----|---------|
|                | Hatchability (%)          |     |         |
| Fish Eggs:     |                           |     |         |
| bay anchovy    | 74                        | 93  | 98      |
| Sciaenidae     | 80                        | 80  | 90      |
|                | Latent 48-Hr Survival (%) |     |         |
| Fish Larvae:   |                           |     |         |
| bay anchovy    | 68                        | 65  | 59      |
| Sciaenidae     | 63                        | 66  | 61      |
| Invertebrates: |                           |     |         |
| Caridea        | 67                        | 66  | 88      |
| Xanthidae      | 80                        | 71  | 85      |
| Pinnotheridae  | 71                        | 65  | 74      |

As part of the evaluation of the fine-mesh screens, an auditing program was established to monitor the conditions of the screens and optimize their screening efficiency. The biggest O&M problem at this site is biofouling (particularly barnacles and mussels). It was found that biweekly manual cleaning of the screens by a two-person crew was effective in preventing damage to the screen mesh and seals.

## Indian Point Generating Station

The Unit 2 intake of Indian Point Generating Station was modified by installing a Ristroph-modified traveling screen (Consolidated Edison Company of New York, Inc. 1986). The modification came, in part, as a provision of the 1980 Hudson River Settlement Agreement. The parties to the settlement agreed that Ristroph traveling screens could be the best alternative to an angled screen and approved testing of one of the screens at Indian Point during winter and early spring of 1985. The study's objective was to obtain initial data on the survival of target species while testing the mechanical reliability of the new screen. The Indian Point Generating Station is located on the eastern bank of the Hudson River 69 river km (43 miles) north of the Battery. Unit 1 has a capacity of 17.6 m<sup>3</sup>/sec (622 cfs). At full capacity, water velocity at the intake forebays is 0.27 m/sec (0.9 ft/s). A 9.5-mm (3/8-in.) fixed screen, bar rack, and conventional traveling screen were used to exclude fish, debris, and other objects from the once-through cooling water system (Figure 2-14).

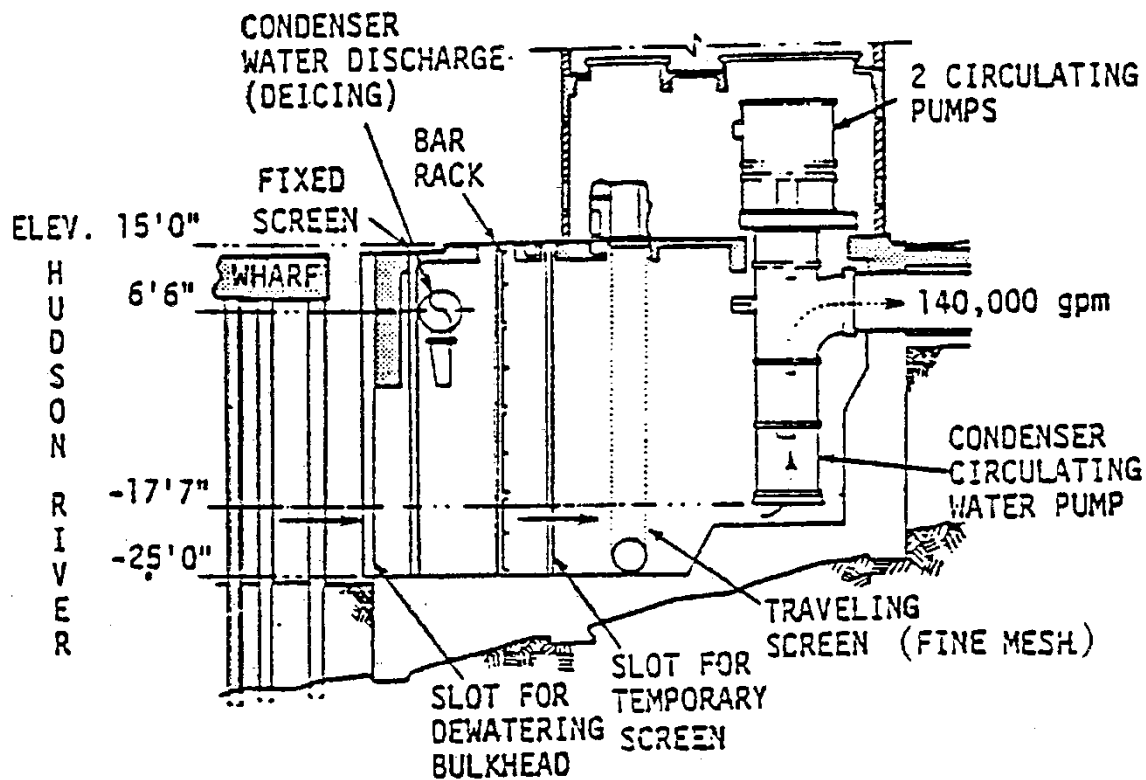


Figure 2-14  
Section view of Indian Point Generating Station Unit 1 CWIS (EA 1977)

Unit 2 has six intake bays (numbered 21–26) that provide once-through cooling water. Each intake bay has a fixed screen, bar rack, and a conventional traveling screen, as described for Unit 1. The circulating system was operated at 60% of maximum capacity from November through December, resulting in an average intake approach velocity of 0.15 m/sec (0.5 ft/sec). From August through October, the circulating pumps operated at 100% capacity bringing intake approach velocities to approximately 0.27 m/sec (0.9 ft/sec). A Ristroph modified traveling

screen was installed in one of the intake bays (number 26) about mid-way between the entrance to the intake bay and the existing conventional screen. The new screen could be operated at variable speeds of up to 6.1 m/min (20 ft/min) but was operated at 3.0 m/min (10 ft/min) for the study period. The screen mesh was constructed of 1.27 by 1.27 cm (0.5 by 0.5-in.) slotted woven wire. Each screen basket was fitted with a fish lifting trough. They discharged into a sluice trough as the screen panels were cleaned by two low-pressure wash headers. One header was located inside the screen, the other was located outside and above the screen (low-pressure washes were operated at approximately 10 psi for this study). Below the fish sluice a high-pressure spray (operated at 95 psi) washed any debris and remaining fish off the screen panels. The fish sluice led fish to various collection tanks where fish were counted and their condition assessed. Fish were then transported to a holding facility for 96-hr observation.

Fish samples were collected simultaneously from trash and debris sluices. A total of 5,861 fish were collected representing 20 species. Water quality parameters, including water temperature, dissolved oxygen, and salinity were monitored in front of the intake and in the holding facilities. No attempt was made however to identify factors associated with differences in survival due to these environmental factors.

Between August 15 and December 27 in situ collections were made. Survival estimates were made each month for nine species. White perch made up the majority (71%) of the fish collected. Survival ranged from 20% for alewife ( $n = 15$ ) to 93.4% for weakfish ( $n = 456$ ) (Table 2-25). Survival rates of striped bass, weakfish, and white perch were found to be higher in late summer and early fall than in November and December (Table 2-26). Simultaneous collections from the fish and debris sluices were made between November 18 and December 24. A total of 2,394 fish representing 16 species were collected from the fish sluice, and 1,065 fish representing 14 species were collected from the debris sluice.

**Table 2-25**  
**Survival (%) of fish collected from a Ristroph screen (fish sluice only) at Indian Point Unit 2 and held for 96 hrs in situ; August 15 through December 27, 1985 (CONED 1986)**

| Species          | Species/Time <sup>1</sup> | Number of Fish |         |      | % Survival  |                         |
|------------------|---------------------------|----------------|---------|------|-------------|-------------------------|
|                  |                           | Alive          | Damaged | Dead | Alive/Total | Alive & Damaged / Total |
| alewife          | September                 | 1              | 0       | 0    | 100.0       | 100.0                   |
|                  | October                   | 2              | 1       | 9    | 16.6        | 25.0                    |
|                  | November                  | 0              | 0       | 1    | 0.0         | 0.0                     |
|                  | December                  | 0              | 0       | 1    | 0.0         | 0.0                     |
|                  | Total                     | 3              | 1       | 11   | 20.0        | 26.7                    |
| American shad    | August                    | 1              | 0       | 0    | 100.0       | 100.0                   |
|                  | September                 | -              | NS      | -    | -           | -                       |
|                  | October                   | 6              | 0       | 3    | 66.7        | 66.7                    |
|                  | November                  | 0              | 0       | 4    | 0.0         | 0.0                     |
|                  | Total                     | 7              | 0       | 7    | 50.0        | 50.0                    |
| Atlantic tomcod  | August                    | 181            | 1       | 77   | 69.9        | 70.3                    |
|                  | September                 | -              | NS      | -    | -           | -                       |
|                  | October                   | 2              | 0       | 1    | 66.7        | 66.7                    |
|                  | November                  | 1              | 0       | 0    | 100.0       | 100.0                   |
|                  | December                  | 29             | 0       | 3    | 90.6        | 90.6                    |
|                  | Total                     | 213            | 1       | 81   | 72.2        | 72.5                    |
| bay anchovy      | August                    | 25             | 2       | 25   | 48.1        | 51.9                    |
|                  | September                 | -              | NS      | -    | -           | -                       |
|                  | October                   | 4              | 0       | 16   | 20.0        | 20.0                    |
|                  | November                  | 0              | 0       | 1    | 0.0         | 0.0                     |
|                  | December                  | -              | NS      | -    | -           | -                       |
|                  | Total                     | 29             | 2       | 42   | 39.7        | 42.5                    |
| blueback herring | August                    | 5              | 0       | 3    | 62.5        | 62.5                    |
|                  | September                 | -              | NS      | -    | -           | -                       |
|                  | October                   | 131            | 4       | 52   | 70.1        | 72.2                    |
|                  | November                  | 45             | 1       | 46   | 48.9        | 50.0                    |
|                  | December                  | 0              | 0       | 1    | 0.0         | 0.0                     |
|                  | Total                     | 181            | 5       | 102  | 62.8        | 64.6                    |
| rainbow smelt    | August                    | -              | NS      | -    | -           | -                       |
|                  | September                 | -              | NS      | -    | -           | -                       |
|                  | October                   | -              | NS      | -    | -           | -                       |
|                  | November                  | 1              | 0       | 2    | 33.3        | 33.3                    |
| rainbow smelt    | December                  | 1              | 0       | 2    | 33.3        | 33.3                    |

| Species      | Species/Time <sup>1</sup> | Number of Fish |         |       | % Survival  |                         |
|--------------|---------------------------|----------------|---------|-------|-------------|-------------------------|
|              |                           | Alive          | Damaged | Dead  | Alive/Total | Alive & Damaged / Total |
|              | Total                     | 2              | 0       | 4     | 33.3        | 33.3                    |
| striped bass | August                    | 15             | 0       | 3     | 83.3        | 83.3                    |
|              | September                 | -              | NS      | -     | -           | -                       |
|              | October                   | 14             | 0       | 2     | 87.5        | 87.5                    |
|              | November                  | 6              | 1       | 7     | 42.9        | 50.0                    |
|              | December                  | 11             | 0       | 14    | 44.0        | 44.0                    |
|              | Total                     | 46             | 1       | 26    | 63.0        | 64.4                    |
| weakfish     | August                    | 420            | 2       | 13    | 96.6        | 97.0                    |
|              | September                 | 5              | 0       | 0     | 100.0       | 100.0                   |
|              | October                   | 0              | 1       | 10    | 0.0         | 9.1                     |
|              | November                  | 1              | 0       | 4     | 20.0        | 20.0                    |
|              | December                  | NS             | -       | -     | -           | -                       |
|              | Total                     | 426            | 3       | 27    | 93.4        | 94.1                    |
| white perch  | August                    | 127            | 2       | 14    | 88.8        | 90.2                    |
|              | September                 | 5              | 0       | 6     | 45.5        | -                       |
|              | October                   | 73             | 2       | 20    | 76.8        | 78.9                    |
|              | November <sup>2</sup>     | 384            | 1       | 231   | 62.3        | 62.5                    |
|              | December <sup>2</sup>     | 1,839          | 16      | 848   | 68.0        | 68.6                    |
|              | Total <sup>2</sup>        | 2,428          | 21      | 1,119 | 68.0        | 68.6                    |

<sup>1</sup> Reflects all individuals in all collections made from August through December.

<sup>2</sup> An additional 80 and 497 fish collected in November and December, respectively, suspected of having been washed from the fixed screens at Intakes 21-25 prior to collection, were excluded.

**Table 2-26**

**Survival of fish collected from a Ristroph screen (fish sluice only) at Indian Point Unit 2 and held for 96 hrs in situ; November 8 through December 27, 1985 (ConEd 1986)**

| Species          | Number of Fish |         |      | % Survival Damaged |                       |
|------------------|----------------|---------|------|--------------------|-----------------------|
|                  | Alive          | Damaged | Dead | Alive/Total        | Alive & Damaged/Total |
| American eel     | 27             | 1       | 12   | 67.5               | 70.0                  |
| banded killifish | 45             | 0       | 2    | 95.7               | 95.7                  |
| black crappie    | 5              | 0       | 1    | 83.3               | 83.3                  |
| bluegill         | 127            | 0       | 3    | 97.7               | 97.7                  |
| gizzard shad     | 3              | 0       | 21   | 12.5               | 12.5                  |
| grey snapper     | 1              | 1       | 7    | 11.1               | 22.2                  |
| hogchoker        | 174            | 1       | 10   | 94.1               | 94.6                  |
| naked goby       | 6              | 0       | 7    | 46.2               | 46.2                  |
| pumpkinseed      | 14             | 0       | 1    | 93.3               | 93.3                  |
| spottail shiner  | 2              | 0       | 0    | 100.0              | 100.0                 |
| white catfish    | 21             | 0       | 4    | 84.0               | 84.0                  |

Additional studies were conducted at Indian Point Unit 1 to determine the survival of early life stages of striped bass impinged on a continuously rotating fine-mesh traveling screen. Evaluations were performed to test the efficiency of the screen in reducing entrainment of aquatic organisms (EA 1977). Other studies were performed by Texas Instruments in 1977 (TI 1978) and by Ecological Analysts 1978 (EA 1979) to evaluate the effectiveness of the fine-mesh screen at Unit 1.

The Unit 1 conventional traveling screen was replaced by an experimental continuously operating fine-mesh traveling screen. The panels of the conventional traveling screen were replaced with 2.5-mm (0.1-in.) nylon mesh screening cloth. The screen was also modified to operate at speeds ranging from 0.76 to 6.1 m/min (2.5 to 20 ft/min). In addition, fish collection buckets that spanned the length of the screens (3 m [10 ft]) were added to enhance the survival of impinged organisms. Fish were removed from the screens by a backwash spray system. Two low-pressure nozzles, operated at 20 and 32 psi, removed impinged organisms from the screen and washed them into a fiberglass trough. A high-pressure wash, located below the fish trough, removed debris from the screen. Larvae and juvenile fish impinged on the fine-mesh traveling screen were collected by diverting water from the bypass sluiceway into a collection apparatus. The collection device consisted of an inverted conical net suspended in a cylindrical tank filled with water. A modified funnel was affixed to the bottom of the net and led into a collection container. At the end of a sample interval, the diverted flow was shut off, and the tank was drained. The net was then washed with a fine spray to remove all of the collected organisms.



Collection efficiency of the fine-mesh screen was determined by releasing a known number of striped bass post-yolk-sac larvae upstream of the fine-mesh traveling screen for collection. Screen washwater was diverted 10 min subsequent to the larval release, after which the number of larvae were collected and recorded. Collection efficiency experiments used two groups of approximately 5,000 and one group of approximately 10,000 post-yolk-sac larvae that were 14 days old (mean length 7 mm [0.28 in.]). An additional efficiency experiment used an estimated 78,750 post-yolk-sac larvae that were 21 days old (mean length 9 mm [0.35 in.]). A control group of 25 post-yolk-sac larvae (21 days old), and 5 mm (0.2 in.) styrofoam particles, representing fish eggs, were also introduced directly into the sluiceway.

Wild Hudson River larvae were used in the impingement survival tests. Tests were conducted during times when river densities of striped bass (*Morone saxatilis*) larvae were known to be high. Collections were made between 2020 and 2140 hrs on June 16 and June 21. Samples were then immediately transported to an onsite laboratory where they were sorted, classified (as live, stunned, or dead), and held for latent mortality observations. Survival of striped bass impinged on traveling screens was calculated as the ratio of organisms found alive to the total number collected.

The results indicated that the continuously operating fine-mesh screen did not effectively prevent the entrainment of striped bass post-yolk-sac larvae that were 7 to 9 mm (0.28 to 0.35 in.) in length. Late post-yolk-sac larvae ranging in size from 10 to 18 mm (0.39 to 0.71 in.) appeared to be the minimum sized larvae collected by the fine-mesh (2.5 mm) screen (EA 1977).

Initial survival of late post-yolk-sac larvae was estimated to be 68% with water intake velocities of 0.12 m/sec (0.4 ft/sec) and screen travel rate of 3 m/min (10 ft/min). Ninety-six-hr survival of late post-yolk-sac larvae was 47%. Early juvenile striped bass (17 to 23 mm [0.67 to 0.91 in.]) survival was 100% for initial survival tests and 88% after 96 hrs (Table 2-27). A total of 119 wild striped bass were collected for impingement survival analysis. One hundred and three were late post-yolk-sac larvae, and 16 were classified as juveniles. High survival of juvenile striped bass indicated that the fine-mesh traveling screen had potential to reduce the mortality of this life stage.

**Table 2-27**  
**Initial and 96-hr survival for post-yolk-sac larvae and juveniles at Indian Point Generating Station (EA 1977)**

| Species         | Post-Yolk-Sac Larvae |             |              | Juveniles   |              |              |
|-----------------|----------------------|-------------|--------------|-------------|--------------|--------------|
|                 | Sample Size          | % Alive (a) |              | Sample Size | % Alive      |              |
|                 |                      | Initial     | 96 Hr        |             | Initial      | 96 Hr        |
| striped bass    | 103                  | 68 (58, 77) | 47 (37, 57)  | 16          | 100          | 88 (62, 99)  |
| white perch     | 7                    | 43 (12, 82) | 14 (1, 67)   | 1           | 100          | 0            |
| bay anchovy     | 1                    | 0           | 0            | 7           | 86 (48, 100) | 0            |
| bluefish        | 0                    | --          | --           | 3           | 67 (9, 99)   | 0            |
| tomcod          | 0                    | --          | --           | 39          | 100          | 67 (51, 81)  |
| rainbow smelt   | 0                    | --          | --           | 6           | 100          | 17 (0, 64)   |
| herring         | 2                    | 0           | 0            | 3           | 33 (1, 91)   | 0            |
| <u>Controls</u> |                      |             |              |             |              |              |
| striped bass    | 15                   | 100         | 80 (52, 96)  | 25          | 100          | 96 (80, 100) |
| white perch     | 6                    | 100         | 83 (36, 100) | 10          | 100          | 100          |

<sup>a</sup> Proportion alive calculated using live plus stunned organisms.  
 (numbers in parentheses indicate 95% confidence interval; from Ostle and Mensing 1977 as cited in EA 1977).

From June through December 1977, Texas Instruments (TI 1978) conducted preliminary studies to test the initial and extended survival of juvenile and older fish recovered from the Unit 1 fine-mesh traveling screen. The testing procedure was similar to that used in the EA study. Seventeen tests were performed. Of these, 16 were conducted with circulator capacity at 78% of maximum and one with circulators at 100% capacity. Screen wash water from the fine-mesh screen was diverted into a 1,672 L (441 gal) collection tank. Fish were removed from the tank, and those classified as live were placed in a laboratory holding facility and observed to determine latent mortality at 0, 12, 36, 60 and 84 hrs. No control tests were conducted. Bay anchovy (*Anchoa mitchilli*), blueback herring (*Alosa aestivalis*), and white perch (*Morone americana*) were the predominant species collected. Species age classes included young-of year, yearling, and older fish. Initial survival for all species was 41%, and survival after 84 hrs was 24% for all species. Overall effectiveness of the continuously operating fine-mesh screen was not fully evaluated due to the preliminary nature of the study.

A continuation of the 1977 studies involving the use of a fine-mesh traveling screen at Indian Point Unit 1 was conducted during the 1978 ichthyoplankton entrainment season (EA 1979). The study objectives were to further define the collection efficiency of the screen and to examine the survival of early life stages of striped bass collected by the screen. The tests used identical sampling apparatus and experimental protocol as the studies conducted in 1977. A total of 38,700 striped bass (*Morone saxatilis*) yolk-sac-larvae were used in three releases. Only 835 were recovered (2.2%).

Collection efficiency of the fine-mesh screen was found to be substantially higher for the juvenile life stage of striped bass. Results from the juveniles tested (n=17,000) in six experiments indicated that 43.6% (n=7,407) were retrieved in the collection apparatus. A total of 35 survival experiments were conducted with wild Hudson River striped bass larvae. All larvae collected were dead. Initial survival of juvenile striped bass was 77%, and survival at 96 hrs was 60%. Survival estimates for early stages of striped bass impinged on fine-mesh traveling screens during 1977 and 1978 studies indicated that, as length increased (the fish became a size more susceptible to screen retention), fish survival also increased. The authors estimated that, for juveniles averaging 19 mm (0.7 in.) or more in length, screen retention would approach 100%, and survival would exceed 75%.

### ***Brunswick Steam Electric Plant***

A biological monitoring program was conducted at Brunswick Steam Electric Plant to determine the impact of its operation on commercially and recreationally important species of fish and shellfish (Carolina Power & Light 1985a; Thompson 2000). Additional evaluations were conducted to determine the effect of fish protection devices and operational practices, including the installation of fine-mesh screens, on fish survival. The monitoring program and intake modifications were implemented as a requirement of the station's NPDES permit.

The Brunswick Plant is located in the Cape Fear estuary approximately 9.2 km (5.7 miles) upstream from the mouth of the Cape Fear River. The plant consists of two generating units, each rated at 790 MW. Cooling water is drawn into the plant through a 4.8 km (3 miles) intake channel. A diversion structure designed to exclude larger life stages of fish was installed in fall of 1982 at the mouth of the intake canal.

Two of the four intake traveling screens 9.5 mm (3/8 in.) on each of the station's units were replaced with 1-mm (0.04-in.) fine-mesh polyester screens. The fine-mesh screens were only run when the intake water temperature was less than or equal to 18°C (65°F). Studies were conducted to determine the reduction in entrainment of organisms due to installation of the fine-mesh screens. Three comparative studies were conducted in November 1984, December 1984, and January 1985. Samples were collected from the two screen types in two consecutive 24-hr periods. Gobies (*Gobiosoma* spp.) comprised 24% of the mean density of all organisms entrained in 1984. Atlantic croaker (*Micropogonias undulatus*) made up 16%, while spot (*Leiostomus xanthurus*) and anchovies (*Anchoa* spp.) each made up 15% of the entrained organisms. The total rate of fish entrained during the study ranged from 6.6 million per day in mid January to 22,000 in mid November. The comparative study involving the fine-mesh screens versus the 9.4-mm (0.4-in.) screens resulted in an 84% reduction in the total number of fish entrained during the three study periods due to the fine-mesh screens.

Impingement studies at Brunswick Station were conducted for larval, juvenile, and adult life stages of fish. Impinged larval life stages were collected by filtering the entire water column in the return flume by using a 505- $\mu$ m mesh plankton net. Five-min samples were collected on mid and slack tides per 24-hr period, per week. Samples were processed in the same manner as the entrainment samples. A total of 570 million larval organisms representing 99 taxa were collected during 1984. Atlantic croaker was the most abundant species collected, representing 22.9% of the total catch. Spot (*Leiostomus xanthurus*) was collected in similar volume, comprising 20.9%. Survival studies were not conducted on the larval collections.

Impingement tests performed with juvenile and adult fish and invertebrate were conducted with the permanent diversion structure in place. Samples were conducted for one 24-hr period each week. A steel-framed collection basket, fitted with 9.4-mm (0.4-in.) netting, was placed into each sluice. Organisms that were collected by the basket were sorted, identified, measured, and weighed. Any organism less than 25 mm (1.0 in.) in length was considered an incidental catch and not recorded. A total of 5,128,817 organisms representing 116 taxa were collected during the juvenile/adult impingement study. Bay anchovy were collected in the greatest number, comprising 59.0% of the total catch. Atlantic menhaden (*Brevoortia tyrannus*) were the second most abundant species and made up 12.8% of the catch. Blue crab (*Callinectes sapidus*) (5.6%), Atlantic silverside (*Menidia menidia*) (4.0%), blackcheek tonguefish (*Symphurus plagiusa*) (2.6%), and Atlantic croaker were third, fourth, fifth, and sixth, respectively. Night sampling was responsible for collecting 78% of the juveniles/adults during the test period.

Survival studies were conducted to determine what percentage of fish and invertebrates impinged on the traveling intake screens could be returned to the estuary alive. Screen washwater was collected at the end of each sluiceway for 3-min intervals using a 1 mm (0.04 in.) mesh bucket. Organisms were collected at two different screen rotation speeds: slow and fast. The collected organisms were transported to a laboratory holding facility and monitored for 96-hr mortality. A control study was also conducted to determine if significant mortality was associated with the collection and holding processes. No adjustments were made for collection or holding. Over 21,000 organisms were collected; 10,700 of these were held for 96 hrs for determining the survival percentages (Table 2-28 and Table 2-29). Survival was generally higher for smaller organisms tested on fast-moving screens. No significant difference in survival was exhibited between screen speeds for larger organisms.

**Table 2-28**  
**Brunswick Station impingement survival study results: screen mortality — 1984 and 1985 (Carolina Power and Light 1985a)**

| Taxon Collected          | Screen Speed | Number of Trials | Number Collected | Number Stocked | Initial Mortality <sup>a</sup> (%) | Latent Mortality <sup>b</sup> (%) | Total Survival <sup>c</sup> (%) |
|--------------------------|--------------|------------------|------------------|----------------|------------------------------------|-----------------------------------|---------------------------------|
| croaker — group 1        | F            | 15               | 2,903            | 1,285          | 39.6                               | 52.2                              | 28.9                            |
| croaker — group 2        | F            | 5                | 584              | 338            | 36.0                               | 43.8                              | 36.0                            |
| spot — group 1           | F            | 8                | 1,349            | 620            | 19.0                               | 61.8                              | 31.0                            |
| pink and white shrimp    | F            | 6                | 264              | 219            | 1.4                                | 5.5                               | 92.7                            |
| brown shrimp             | F            | 2                | 87               | 81             | 7.9                                | 25.9                              | 69.0                            |
| penaeid postlarvae       | F            | 2                | 188              | 120            | 4.3                                | 5.8                               | 90.2                            |
| blue crab                | F            | 4                | 170              | 79             | 2.4                                | 5.1                               | 92.7                            |
| blue crab megalops       | F            | 2                | 159              | 71             | 1.9                                | 11.3                              | 88.9                            |
| weakfish                 | F            | 4                | 282              | 191            | 19.4                               | 82.2                              | 12.6                            |
| searobin                 | F            | 4                | 132              | 124            | 2.3                                | 8.1                               | 89.8                            |
| blackcheek tonguefish    | F            | 3                | 110              | 95             | 5.5                                | 15.8                              | 79.6                            |
| bay anchovy              | F            | 2                | 249              | 114            | 54.2                               | 100.0                             | 0.0                             |
| striped mullet — group 1 | F            | 1                | 62               | 52             | 16.1                               | 19.2                              | 67.7                            |
| striped mullet — group 2 | F            | 1                | 37               | 37             | 0.0                                | 8.1                               | 91.9                            |
| flounder                 | F            | 1                | 91               | 78             | 8.9                                | 1.3                               | 90.0                            |
| menhaden                 | F            | 1                | 32               | 30             | 6.3                                | 83.3                              | 15.6                            |
|                          |              |                  |                  |                |                                    |                                   |                                 |
| croaker — group 1        | S            | 12               | 2,105            | 772            | 60.1                               | 77.3                              | 9.6                             |
| croaker — group 2        | S            | 6                | 597              | 420            | 15.4                               | 57.9                              | 35.6                            |
| spot — group 1           | S            | 9                | 1,806            | 767            | 39.1                               | 87.6                              | 7.6                             |
| spot — group 2           | S            | 3                | 333              | 219            | 27.9                               | 61.2                              | 28.0                            |
| pink and white shrimp    | S            | 1                | 48               | 44             | 8.3                                | 11.4                              | 81.2                            |
| brown shrimp             | S            | 3                | 249              | 241            | 3.2                                | 7.9                               | 89.2                            |

| <b>Taxon Collected</b> | <b>Screen Speed</b> | <b>Number of Trials</b> | <b>Number Collected</b> | <b>Number Stocked</b> | <b>Initial Mortality<sup>a</sup> (%)</b> | <b>Latent Mortality<sup>b</sup> (%)</b> | <b>Total Survival<sup>c</sup> (%)</b> |
|------------------------|---------------------|-------------------------|-------------------------|-----------------------|------------------------------------------|-----------------------------------------|---------------------------------------|
| penaeid postlarvae     | S                   | 2                       | 131                     | 119                   | 9.2                                      | 15.1                                    | 77.1                                  |
| blue crab              | S                   | 1                       | 26                      | 20                    | 7.7                                      | 0.0                                     | 92.3                                  |
| blue crab megalops     | S                   | 2                       | 203                     | 135                   | 3.0                                      | 11.1                                    | 86.3                                  |
| bay anchovy            | S                   | 1                       | 596                     | 59                    | 90.1                                     | 100.0                                   | 0.0                                   |
| hardback shrimp        | S                   | 1                       | 123                     | 41                    | 66.7                                     | 34.1                                    | 22.0                                  |

F = Fast-screen operation.

S = Slow-screen operation.

<sup>a</sup>Number of organisms that were found dead in collection gear ÷ number collected.

<sup>b</sup>Number of organisms that died after being stocked in tanks ÷ number stocked.

<sup>c</sup>100 - [(a) (Number collected) + (b) (Number stocked) + (b) (Other live organisms collected but not stocked)] ÷ number collected.

**Table 2-29**  
**Brunswick Station impingement survival study results: control mortality — 1984 and 1985 (Carolina Power and Light 1985a)**

| Taxon Collected          | Screen Speed | Number of Trials | Number Collected | Number Stocked | Initial Mortality <sup>a</sup> (%) | Latent Mortality <sup>b</sup> (%) |
|--------------------------|--------------|------------------|------------------|----------------|------------------------------------|-----------------------------------|
| croaker — group 1        | 16           | 1,392            | 1,095            | 14.1           | 9.9                                | 77.4                              |
| croaker — group 2        | 9            | 2,550            | 611              | 0.9            | 1.8                                | 97.4                              |
| spot — group 1           | 10           | 1,361            | 895              | 7.1            | 12.9                               | 80.9                              |
| spot — group 2           | 3            | 973              | 213              | 0.6            | 0.9                                | 98.5                              |
| pink and white shrimp    | 7            | 561              | 347              | 2.7            | 4.9                                | 92.4                              |
| brown shrimp             | 5            | 323              | 304              | 3.4            | 23.4                               | 72.7                              |
| Penaeid postlarvae       | 2            | 115              | 112              | 2.6            | 8.0                                | 89.6                              |
| blue crab                | 5            | 238              | 100              | 0.0            | 6.0                                | 94.1                              |
| blue crab megalops       | 4            | 362              | 231              | 7.2            | 7.4                                | 86.9                              |
| weakfish                 | 3            | 155              | 116              | 3.2            | 40.5                               | 51.0                              |
| searobin                 | 4            | 104              | 97               | 1.9            | 1.0                                | 96.8                              |
| blackcheek tonguefish    | 3            | 444              | 116              | 0.2            | 2.6                                | 97.6                              |
| bay anchovy              | 2            | 60               | 48               | 20.0           | 56.3                               | 29.3                              |
| striped mullet — group 1 | 1            | 23               | 23               | 0.0            | 4.3                                | 95.7                              |
| striped mullet — group 2 | 1            | 35               | 35               | 0.0            | 0.0                                | 100.0                             |
| flounder                 | 1            | 21               | 20               | 4.8            | 0.0                                | 95.2                              |
| hardback shrimp          | 1            | 51               | 50               | 2.0            | 8.0                                | 90.3                              |

<sup>a</sup>Number of organisms that were found dead in collection gear ÷ number collected.

<sup>b</sup>Number of organisms that died after being stock in takes ÷ number stocked.

<sup>c</sup>100 - [(a) (number collected) + (b) (number stocked) + (b) (other live organisms collected but not stocked)] ÷ number collected.

## **Danskammer Point Generating Station**

Central Hudson Gas & Electric installed a front-wash modified screen system in 1979 at the Danskammer Point Generating Station (EA 1982). Subsequent to the system installation in 1979, studies were conducted to evaluate the effectiveness of the modified screens at improving the survival rates of impinged fish compared to conventional screens. The plant is located approximately 107 km (66.5 miles) upstream from the mouth of the Hudson River at the north end of Newburgh Bay. The station has four units with a total gross generating capacity of 482 MW. Units 1, 2, and 3 each have two pumps to supply water for the once-through cooling system; Unit 4 has three pumps. Water is drawn from a common intake canal through 12 vertical traveling screens. Approximate velocities approaching the screens are less than 0.45 m/sec (1.5 ft/sec).

The conventional traveling screens each had 25, 0.46- by 2.44-m (1.5- by 8-ft) screen panels fitted with 9.5-mm (3/8-in.) mesh. A single high-pressure (60 to 90 psi) debris spray nozzle washed both fish and debris from the screens into a sluiceway located in front of the screens. The screens were operated at a rotational speed of 1.6 m/min (5.2 ft/min). One of the three traveling screens in Unit 4 was selected for modifications, including stainless steel troughs installed at the base of each screen panel, external low-pressure fish-removal spray, a neoprene-faced splash plate, and two high-pressure crossfire spray jets.

A series of preoperational screenwash tests were performed to determine the efficiency of the low-pressure wash system when used alone and in conjunction with the high-pressure debris spray. A known number of living and dead fish of several size categories were placed in the screen trays prior to washing. The screen was then rotated and washed and fish were collected at the fish sluice discharge. The number of fish collected in the discharge was recorded. Observations were also made at the backside of the screens to determine if any fish were being carried over.

A comparison of survival was conducted between fish removed from the modified screen versus fish removed from the two conventional traveling screens located on either side of the modified screen. Each week, two modes of screen wash operation were tested. In one operational mode, 30-min collections were made during continuous screenwash and continuous screen rotation. The other operational mode employed was intermittent screen rotation with a two-hr hold followed by screen rotation and wash for 15 min. Sampling was conducted three times per week for each screen type and wash/operational mode.

The collection of fish from each of the two screen types occurred at the point where the screenwash sluiceway emptied into the Hudson River. The washwater was directed into a collection basket (120 by 240 by 120 cm [47.2 by 94.5 by 47.2 in.]) equipped with 6-mm (0.2-in.) mesh. Fifteen-min samples were collected during the intermittent mode, and 30-min samples were collected during the continuous wash mode. Fish captured in the collection basket were counted and classified by condition. Live specimens of selected target species were transferred to holding tanks for latent mortality observations. Latent mortality monitoring occurred at 12, 18, 36, and 84 hrs after collection.

Control fish were collected from the river near Danskammer to determine if the collection and handling processes had a significant effect on the survival of fishes.



After a 2- to 4-day recovery period, control fish were placed in the collection basket and subjected to the washwater discharge for the same exposure period as the test fish. The control fish were then sorted and maintained in the same manner as the test fish.

The preoperational screenwash tests indicated that fish removal efficiency was related to the size and condition of the fish. Live fish under 130 mm (5.1 in.) were effectively removed from the screens with a low-pressure wash (10 psi). The removal of fish larger than 130 mm (5.1 in.) improved when the low-pressure wash was increased to 15 psi. Dead fish were more effectively removed when both the low and high-pressure washes were used together.

White perch (*Morone americana*), Atlantic tomcod (*Microgadus tomcod*), *Alosa* spp (alewife [*Alosa pseudoharengus*], blueback herring [*Alosa aestivalis*], American shad [*Alosa sapidissima*], and gizzard shad [*Dorosoma cepedianum*]), and spottail shiner (*Notropis hudsonius*) were the most commonly collected species on both types of screens and composed over 80% of the total catch. A total of 5,503 fish were collected by the conventional screens, while the modified screen collected 3,217.

White perch were most abundant in the fall and spring followed closely by Atlantic tomcod during winter months. *Alosa* species were most frequently collected in the fall and spottail shiner were collected in low numbers throughout the year. There was little variation in the size class of fish collected at both screen types.

Initial survival data were recorded for all the fish collected on the screens. Latent survival observations were conducted on only the most abundant species collected. Initial survival rate was comparable between life stages, sampling seasons, and screenwash modes. The initial survival of impinged white perch was high (greater than 90% for the majority of the samples) for all of the sampling seasons (Table 2-30). Survival rates were significantly higher on modified screens for fall 1980 samples involving young-of-the-year fish. Extended survival rates for tests with screens operating in the continuous wash mode during non-winter months were higher at the conventional screens than at the modified screens. The modified screens only showed increased extended survival during the winter test period. Most species collected at the modified screen had lower survival rates than those collected on the conventional screens. Atlantic tomcod was the only species that showed a significantly higher survival rate at the modified screen when sampled during the continuous wash mode (Table 2-31). Results of the control tests indicated that collection and handling had little or no effect on initial survival but did have an influence on extended survival rates for all species tested.

**Table 2-30**  
**Initial and 84-hr survival by species, lifestage, and screenwash mode at the Danskammer Point Plant (EA 1982)**

| Sampling Period | Species         | Life Stage (a) | Screenwash Mode | Screen Type | Time of Observation |            |           |            |    |       |
|-----------------|-----------------|----------------|-----------------|-------------|---------------------|------------|-----------|------------|----|-------|
|                 |                 |                |                 |             | Initial             |            | 84 Hr (b) |            |    |       |
|                 |                 |                |                 |             | Number              | % Survival | Number    | % Survival |    |       |
| Fall 1979       | herrings        | YOY            | Continuous      | Standard    | 190                 | 82.6       | 157       | 1.9        |    |       |
|                 |                 |                |                 | Modified    | 61                  | 68.9       | 42        | 0.0        |    |       |
|                 |                 |                | 2 hr hold       | Standard    | 211                 | 38.4       | 81        | 0.0        |    |       |
|                 |                 |                |                 | Modified    | 127                 | 40.2       | 51        | 0.0        |    |       |
| Fall 1980       |                 |                | Continuous      | Standard    | 191                 | 85.3       | 163       | 21.5       |    |       |
|                 |                 |                |                 | Modified    | 185                 | 77.3*      | 143       | 8.4        |    |       |
|                 |                 |                | 2 hr hold       | Standard    | 962                 | 37.4       | 360       | 0.6        |    |       |
|                 |                 |                |                 | Modified    | 475                 | 27.4*      | 130       | 0.0        |    |       |
| Winter 1980     | Atlantic tomcod | ADL            | Continuous      | Standard    | 52                  | 82.7       | 43        | 60.5       |    |       |
|                 |                 |                |                 | Modified    | 30                  | 96.7*      | 29        | 86.2       |    |       |
|                 |                 |                | 2 hr hold       | Standard    | 50                  | 84.0       | 42        | 71.4       |    |       |
|                 |                 |                |                 | Modified    | 5                   | 100.0      | 5         | 80.0       |    |       |
| Spring 1980     |                 |                | spottail shiner | ADL         | Continuous          | Standard   | 27        | 96.3       | 26 | 100.0 |
|                 |                 |                |                 |             |                     | Modified   | 53        | 100.0      | 53 | 98.1  |
|                 |                 |                |                 |             | 2 hr hold           | Standard   | 71        | 95.8       | 68 | 60.3  |
|                 |                 |                |                 |             |                     | Modified   | 22        | 100.0      | 22 | 54.5  |

(a) YOY = young of the year; ADL = adult.

(b) Normalized data.

\* Indicates that a significant ( $\alpha = 0.05$ ) difference between survival proportions for the two screen types was detected.

**Table 2-31**  
**Initial and 84-hr survival of control species, lifestage, and screenwash mode at the Danskammer Point Plant (EA 1982)**

| Sampling Period | Species         | Life Stage (a) | Screenwash Mode | Time of Observation |         |                   |         |
|-----------------|-----------------|----------------|-----------------|---------------------|---------|-------------------|---------|
|                 |                 |                |                 | Initial Survival    |         | 84 Hr Survival(b) |         |
|                 |                 |                |                 | Number              | Percent | Number            | Percent |
| Fall 1979       | white perch     | YOY            | Continuous      | 145                 | 100.0   | 145               | 100.0   |
|                 |                 |                | 2 hr hold       | 137                 | 100.0   | 137               | 95.6    |
|                 | herrings        | YOY            | Continuous      | 118                 | 98.3    | 116               | 19.8    |
|                 |                 |                | 2 hr hold       | 131                 | 99.2    | 130               | 21.5    |
| Winter 1980     | Atlantic tomcod | ADL            | Continuous      | 89                  | 100.0   | 89                | 98.9    |
|                 |                 |                | 2 hr hold       | 71                  | 100.0   | 71                | 100.0   |
|                 | white perch     | YRL            | Continuous      | 44                  | 100.0   | 44                | 93.2    |
|                 |                 |                | 2 hr hold       | 43                  | 100.0   | 43                | 86.0    |
| Spring 1980     | white perch     | YRL            | Continuous      | 28                  | 100.0   | 28                | 96.4    |
|                 |                 |                | 2 hr hold       | 38                  | 100.0   | 38                | 84.2    |
|                 |                 | ADL            | Continuous      | 105                 | 100.0   | 105               | 100     |
|                 |                 |                | 2 hr hold       | 103                 | 100.0   | 103               | 95.1    |
|                 | spottail shiner | ADL            | Continuous      | 123                 | 100.0   | 123               | 100.0   |
|                 |                 |                | 2 hr hold       | 113                 | 100.0   | 113               | 100.0   |
| Fall 1980       | white perch     | YOY            | Continuous      | 90                  | 100.0   | 90                | 95.6    |
|                 |                 |                | 2 hr hold       | 141                 | 100.0   | 141               | 94.3    |
|                 | herrings        | YOY            | Continuous      | 115                 | 100.0   | 115               | 73.9    |
|                 |                 |                | 2 hr hold       | 187                 | 100.0   | 187               | 66.3    |

(a) YOY = young of the year; YRL = yearling; and ADL = adult.

(b) Normalized data.

The performance of both the conventional and modified screen types was found to be similar. Atlantic tomcod and white perch exhibited higher survival rates during the winter season of the modified screen. However, survival rates for all other species tested on the modified screen were comparable or less than those exhibited on the conventional screens. The authors suggest that there would be “no particular advantage in using the modified screen system” at the Danskammer plant under the observed conditions.

### **Mystic Station**

The effectiveness of a modified traveling screen was evaluated at Mystic Station — Unit No. 7 in an attempt to improve the survival of winter flounder (*Pseudopleuronectes americanus*), rainbow smelt (*Osmerus mordax*), alewife (*Alosa pseudoharengus*), and blueback herring (*Alosa aestivalis*) (SWEC 1979, 1981; Taft et al. 1986). Mystic Station is located on the north bank of the Mystic River in Everett, MA. Unit 7 has a total generating capacity of 600 MW. The Unit 7 intake consists of two screenbays, each 2.7 m (9 ft) wide. A 2.4 m (8 ft) wide bottom sill was constructed at the base of each screenbay to exclude flounder and other benthic organisms. Angled trash racks are located inside the screenbays. Curtain walls, located behind the trash racks, extend downward approximately 1.4 m (4.5 ft) below the extreme low tide elevation (EL 2.2 m [7.25ft]). Two traveling screens are located 7.8 m (25.5 ft) behind the screenbay entrances. The screen panels are fitted with 1 cm (0.4 in.) wire mesh and are equipped with a front wash, low- (30 psi) and high-pressure (90 psi) screen wash system. Fish and debris are washed into a common sluice. Normal operation of the screens includes one rotation during each 8-hr shift. Screen approach velocities are 1 m/sec (3.2 ft/sec).

During the fall of 1980, one of the two Unit 7 traveling screens was replaced with an experimental screen system. Modifications that were made to the Unit 7 screenwell included installation of fish lifting buckets, a low-pressure spray header, a fish trough, a fish collection/holding facility, a new debris trough, and the relocation of the high-pressure debris spray to the descending run of the screen. The traveling screen was also equipped with a two-speed motor and four-speed transmission, which allowed the screen to operate at speeds ranging from 0.76 to 9.1 m/min (2.5 to 30 ft/min).

Total impingement sampling and impingement survival testing were conducted at the Unit 7 intake. Total impingement sampling involved counting and identifying all fish collected on the both the Unit 7 traveling water screens throughout the study period. The organisms collected from the screen washings for both of the screens were sorted several times per week. Impingement survival sampling was conducted to determine the survival rates of fish collected by the traveling screens. The tests were conducted after several screen washings and screen rotations. Organisms were washed from the fish buckets into the fish troughs and entered a collection area where they were categorized by condition and transported to holding pools. The screen was tested at different operational speeds to determine the relationship between screen speed and mortality. The studies were intended to determine a screen speed that would provide low mortality without jeopardizing screen reliability. Fish were collected at screen speeds of 1 and 4.6 m/min (3.3 and 15 ft/min), the longest and shortest impingement durations tested. Intermediate speeds of 2.3 and 3.0 m/min (7.5 and 10 ft/min) were also tested during the fall and winter, respectively. As in the total impingement sampling studies, fish collected from the screens were categorized and placed in holding tanks for 96-hr latent survival assessments.

The most abundant species collected was rainbow smelt, followed by *Alosa* spp. (alewives and blueback herring), and winter flounder. Impingement survival appeared to increase with screen speed. A total of 103,384 fish were collected from the Unit 7 traveling water screens from October 7, 1980, to April 27, 1981. The authors note that 75% of the rainbow smelt collected over the entire study period were collected in 5 weeks. Similarly, almost 50% of the *Alosa* spp. were collected during the week of November 11 to 17, and nearly 60% of the winter flounder were collected in the month of January. *Alosa* spp. were partitioned into two length categories for fall testing because of a distinct pattern of bimodal separation at 10.5 cm (4.1 in.). *Alosa* spp. in the first year of life were listed as “small.” Results of tests at screen speeds of 4.6 m/min (15 ft/min) revealed a survival rate of nearly 50%. The larger *Alosa* spp. had high initial survival but showed low latent survival at all screen speeds. Few (n=16) *Alosa* spp. were collected in the winter. Data indicated that survivorship was similar to large *Alosa* spp. collected during the fall.

Winter flounder were also separated into two different size classes for the fall testing period. Greater than 50% of winter flounder survived impingement even at the slowest screen speeds. A low mortality rate was exhibited by flounder during winter tests (Table 2-32).

**Table 2-32**  
**Mortality of winter flounder (SWEC 1981)**

| Screenwash Interval | Percent Mortality <sup>1</sup> |                    |                    |
|---------------------|--------------------------------|--------------------|--------------------|
|                     | Initial <sup>2</sup>           | 96 Hr <sup>3</sup> | Total <sup>4</sup> |
| Continuous          | 2.6 (0 <sup>5</sup> –16.2)     | 10.3 (0.4–30.7)    | 14.6 (1.0–39.8)    |
| 2 Hr                | 22.3 (5.6–45.9)                | 29.3 (9.3–54.8)    | 44.2 (17.9–72.3)   |
| 4 Hr                | 41.4 (18.6–66.3)               | 58.2 (32.4–81.7)   | 66.2 (37.6–89.4)   |
| 8 Hr                | 35.6 (14.2–60.6)               | 38.6 (15.7–64.4)   | 54.4 (26.3–81.0)   |

<sup>1</sup> Calculated from arcsine transformation.

<sup>2</sup> Percentage of flounder found dead on screens.

<sup>3</sup> Percentage of flounder which died during the 96-hr test period.

<sup>4</sup> Number dead on screen plus number died during 96-hr test period divided by total number of flounder collected.

<sup>5</sup> Confidence interval less than zero.

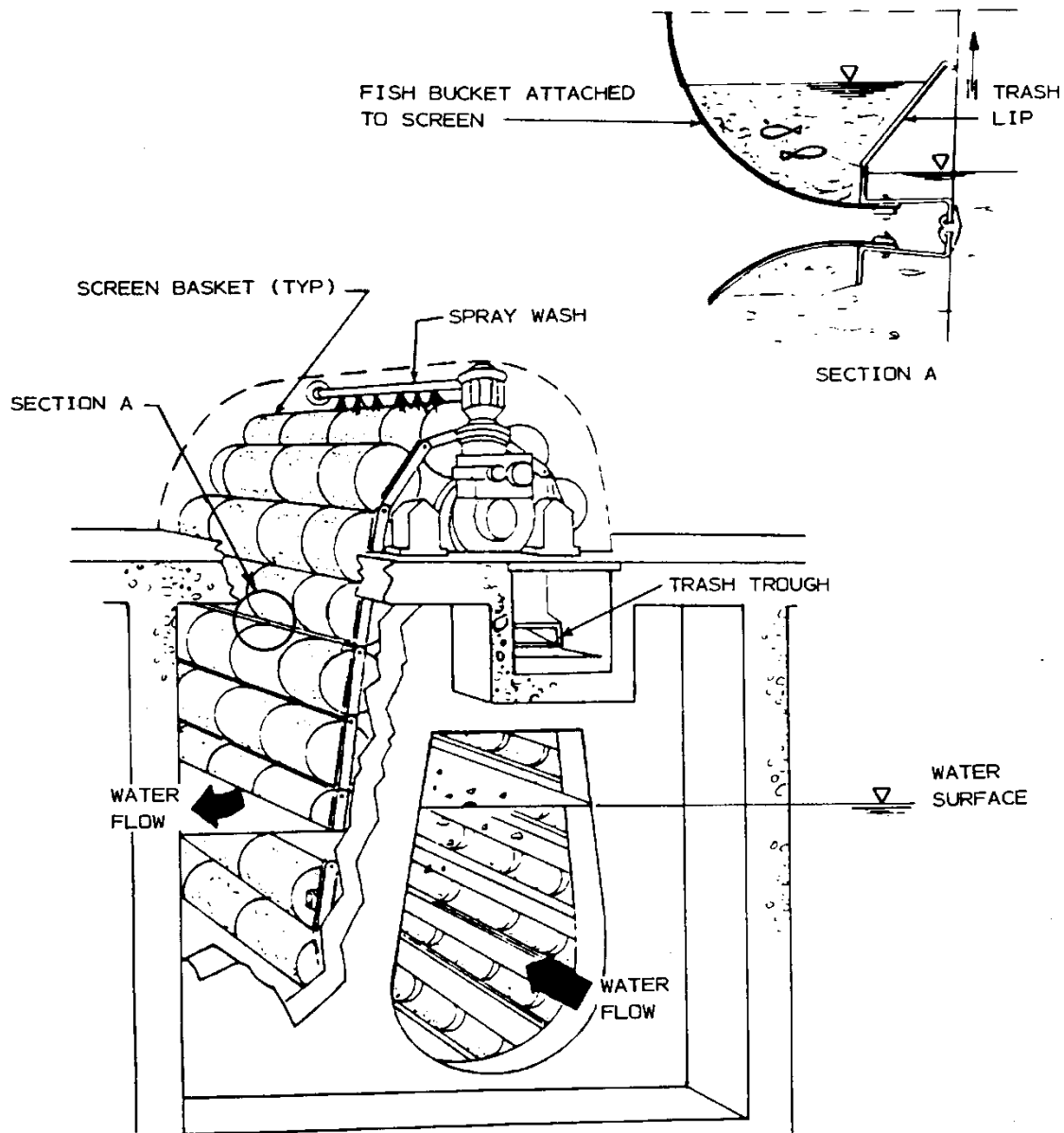
Rainbow smelt were separated into two groups: small, i.e., 9 to 14 cm (3.5 to 5.5 in.); and large, i.e., greater than 14 cm (5.5 in.). Initial survival for large and small rainbow smelt was high for all screen speeds tested. Latent survival was significantly lower, at a screen speed of 1 m/min (3.3 ft/min) than at speeds of 3.0 or 4.5 m/min (10 or 15 ft/min) for both large and small rainbow smelt. The greatest survival for both small and large rainbow smelt was achieved when the screen was operated at 4.5 m/min (15 ft/min).

### **Barney M. Davis Power Station**

A study was conducted to determine the initial survival of impinged marine organisms on Passavant fine-mesh center-flow traveling screens at the Barney M. Davis Power Station (Murray and Jinnette 1978). The study also examined the influence of debris loading on survival of dominant species.

The Barney M. Davis Power Station is located on the shoreline of the upper Laguna Madre near Corpus Christi, Texas. The two units have a total generating capacity of 650 MW. Water for the once-through cooling system is drawn from the Laguna Madre by a 1,174 by 23.5 by 2.4 m (3,850 by 77 by 8 ft) deep intake channel. The intake structure has four 4 m (13 ft) wide intake bays. Each bay incorporates a trash rack with 7.62 cm (3 in.) clear spacings. The Passavant fine-mesh (0.5 mm [0.02 in.]) traveling screens are located 7 m (23 ft) downstream of the trash racks, and the circulating water pumps are 14.6 m (48 ft) behind the screens. Velocities through the fine-mesh screens range from 0.5 to 0.9 m/sec (1.7 to 3.1 ft/sec).

The Passavant fine-mesh, center-flow screen system employs a single entry, double exit design. Each screen is fitted with 53 semicircular screen baskets with a shovel type lip to help retain screened material. Water flows from the inside to the outside of the screen structure. Impinged organisms are removed from the screens by an overhead spray unit operating at 40-60 psi (Figure 2-15).



**Figure 2-15**  
**Center-flow (Passavant) screen (Murray and Jinette 1978)**

Samples were collected on a monthly basis from January to December 1977. Sampling frequency was once every 6 hrs for the 24-hr sampling period. Four individual, 30-second replicates were conducted at each of the four screens for a total sample time of 8 min. Organisms were separated from debris, observed for 10 to 15 min, and then sorted into live and dead (any organism showing no life signs, visible damage or erratic behavior) categories. Latent survival studies were not conducted. Organisms were then placed in marked jars for individual identification and further laboratory quantification. A total of 12,060 individual organisms, representing 15 species of invertebrates and 37 species of vertebrates, were collected by the Passavant screens.

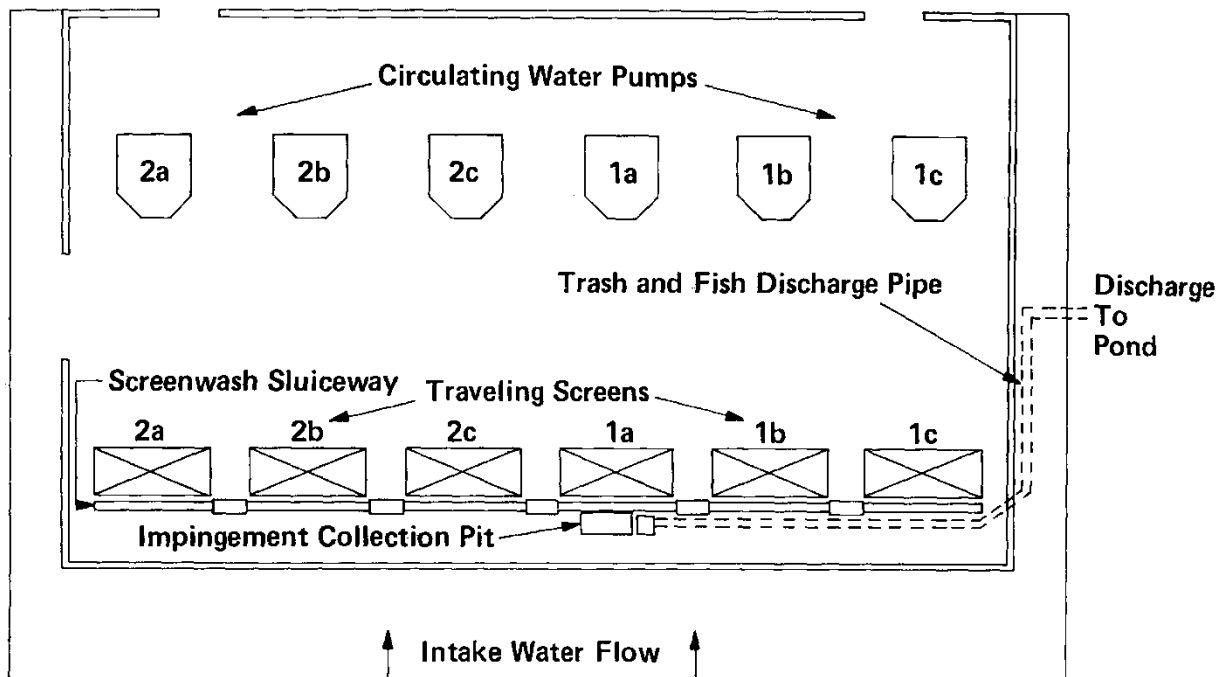
The overall initial survival for all individuals was 86%. Latent survival was not studied. The lowest overall percent mortality for dominant species occurred during February. Gulf menhaden (*Brevoortia patronus*) were the most abundant fish collected in February. They made up for 33% of the total catch and exhibited the lowest mortality (5%). The highest percent mortality was exhibited by bay anchovy during the month of June. Bay anchovy (*Anchoa mitchilli*) represented 74% of the total catch for June and exhibited a 98% mortality rate. The authors suggested that much of the mortality experienced by bay anchovy could have been attributed to the large numbers of cabbagehead jellyfish (*Stomolophus meleagris*) collected in the screen samples. The jellyfish are known to have a paralytic or lethal effect on most fish species they encounter.

The effect of debris loading on the survival of impinged organisms was also investigated. When debris weights fluctuated throughout January, February, and March, the percent mortality tended to follow the same pattern of fluctuation. Low mortality experienced in April, when debris loading was at its peak, was explained by the presumption that the debris composition was a factor. Observations of the debris during spring indicated that algal forms were the dominant composition of the debris loads. It was believed that the algal forms did not entangle organisms on the screens and therefore did not exert the same stresses on impinged organisms that the marine grass-type debris may have at other times.

### **Bowline Point Generating Station**

Studies were conducted at Bowline Point Generating Station to determine the effects of traveling screens used at various screen operational modes and screenwash pressures on survival of young-of-the-year white perch (*Morone americana*), striped bass (*Morone saxatilis*), and adult Atlantic tomcod (*Microgadus tomcod*) (King et al. 1978). The Station is located approximately 60 km (37.3 miles) north of Manhattan on the west bank of Haverstraw Bay in the Hudson River estuary. The station has a total rated generating output of 600 MW for each of its two units (Figure 2-16). Six circulating pumps draw cooling water from a small embayment (Bowline Pond) through six vertical traveling screens. The screen panels are equipped with 0.953 cm (3/8 in.) mesh. Velocities approaching the screen are 15 cm/sec (0.5 ft/sec), with two of the three pumps per unit operating. Bowline Point has two spray wash systems for removing debris and organisms from the screens. A low-pressure wash removes fish from the screens with a pressure of 10 to 20 psi, and a high-pressure system removes debris from the screens with a spray pressure of 30 to 50 psi.





**Figure 2-16**  
**Bowline Point Station intake structure (King et al. 1978)**

Three operational modes were tested at Bowline Point: continuous screen rotation with continuous screen wash, 2-hr hold operation with screen rotation and screen wash for a duration of 20 min once every 2 hrs, and 4-hr hold operation with similar screen and wash operation for 2-hr hold. Pressure wash operational modes tested included the high-pressure system operation alone at 30 to 50 psi, and the high pressure system operating concurrently with the low-pressure system operated between 10 and 20 psi.

Impingement and survival collections were conducted once per week in November and December of 1976 and once per month from January through March of 1977. Collections were taken for 15 to 30 min during screenwash operation. Fish impinged on the screens were collected in the impingement collection pit using a 1.3-cm (1/2-in.) knotless nylon mesh net. Fish were sorted by condition and species immediately after removal from the collection net. Live and stunned fish were transported to a holding facility and observed at 12, 24, 48, and 96–108 hrs for delayed mortality. Water quality was monitored throughout the latent mortality study. Control fish were collected to determine mortality associated with the collection and holding procedures as described in previous reviews.

Results of the initial survival tests indicated that survival was high (69% to 98%) for young-of-the-year white perch during all three screen operational modes and both pressure wash modes (Table 2-33).

**Table 2-33**  
**Initial and 96-hr survival of white perch by screen operation mode at Bowline Point Plant (King et al. 1978)**

| Months                 | Screen Operational Mode | Washwater Pressure (psi) | Time of Observation |            |            |            |        |            |
|------------------------|-------------------------|--------------------------|---------------------|------------|------------|------------|--------|------------|
|                        |                         |                          | Initial             |            | 96 Hr      |            | 108 Hr |            |
|                        |                         |                          | Number              | % Survival | Number (d) | % Survival | Number | % Survival |
| November–December 1976 | Continuous              | 10–20                    | 3,699               | 98 (a)     | 1,474      | 56         | ---    | ---        |
|                        |                         | 30–50                    | 2,192               | 96 (a)     | 779        | 55         | ---    | ---        |
|                        | 2-hr hold               | 10–20                    | 1,169               | 90         | 341        | 26         | ---    | ---        |
|                        |                         | 30–50                    | 1,214               | 90         | 364        | 32         | ---    | ---        |
|                        | 4-hr hold               | 10–20                    | 111                 | 75         | 83         | 19         | ---    | ---        |
|                        |                         | 30–50                    | 143                 | 69         | 98         | 19         | ---    | ---        |
| January–March 1997     | Continuous              | 10–20                    | 952                 | 87 (b)     | ---        | ---        | 824    | 23 (c)     |
|                        |                         | 30–50                    | 903                 | 81 (b)     | ---        | ---        | 730    | 34 (c)     |

(a)  $Z = 4.76$ ; critical value = 1.96;  $\alpha = 0.05$  for two-tailed test; (b)  $Z = 3.33$ ; (c)  $Z = 4.43$ ; (d) Includes subsample of live and stunned fish; (e) Dashes indicate no data.

Initial and latent survival was consistently higher for the continuous mode of operation compared to the 2- or 4-hr hold modes. The operation of the low-pressure screenwash system did not result in significantly greater initial or latent survival than the operation of high-pressure system. The authors postulate that the lack of difference in impingement survival due to screen wash systems may be a result of a number of factors. The low-pressure screenwash may not have effectively removed fish from the traveling screens prior to their contact with the high-pressure system, or both the pressures tested may have been sufficiently low to permit similar survival results. The initial and latent impingement survival for striped bass and white perch were similar for the same screen operational modes during the same months (Table 2-34).

**Table 2-34**  
**Initial and 96-hr survival of white perch and striped bass by screen operation mode at Bowline Point Plant (King et al. 1978)**

| Months                 | Species      | Screen Operational Mode | Time of Observation |             |            |             |        |            |
|------------------------|--------------|-------------------------|---------------------|-------------|------------|-------------|--------|------------|
|                        |              |                         | Initial             |             | 96 Hr      |             | 108 Hr |            |
|                        |              |                         | Number              | % Survival  | Number (g) | % Survival  | Number | % Survival |
| November–December 1976 | white perch  | Continuous              | 5,891               | 97 (b)      | 2,253      | 56 (c)      | ---    | ---        |
|                        |              | 2-hr hold               | 2,383               | 90 (b), (d) | 705        | 29 (c), (e) | ---    | ---        |
|                        |              | 4-hr hold               | 254                 | 71 (d)      | 181        | 19 (e)      | ---    | ---        |
| January–March 1977     | white perch  | Continuous              | 1,855               | 84          | ---        | ---         | 1,554  | 28         |
| January–February 1977  | white perch  | Continuous              | 1,057               | 80          | ---        | ---         | 849    | 21         |
| December 1976          | striped bass | Continuous              | 412                 | 95          | 393        | 62 (f)      | ---    | ---        |
|                        |              | 2-hr hold               | 256                 | 92          | 237        | 26 (f)      | ---    | ---        |
| January–March 1977     | striped bass | Continuous              | 617                 | 90          | ---        | ---         | 555    | 32         |

(a) Data were pooled for screenwash pressures from Tables 1 and 2; (b)  $Z = 13.41$ ; critical value = 1.96;  $\alpha = 0.05$  for two-tailed test; (c)  $Z = 12.50$ ; (d)  $Z = 8.69$ ; (e)  $Z = 2.53$ ; (f)  $Z = 8.72$ ; (g) Includes subsample of live and stunned fish; (h) Dashes indicate no data.

Control survival data for young-of-the-year white perch (there was an insufficient sample size of control striped bass) were used to estimate the probability for surviving impingement. Control tests conducted in November and December on continuously operating screens resulted in 100% initial survival. Initial survival was lower in January and February. There was no observed latent effect for the continuous operational mode.

Traveling screen operational mode was found to affect the probability of young-of-the-year white perch surviving impingement. The authors suggest that striped bass would show a similar response because of the correlation experienced in impingement survival data between the two species. The operation of traveling screens in the continuous operation mode resulted in maximum initial and latent survival.

### **Oyster Creek Generating Station**

Initial and latent mortality studies were conducted at Jersey Central Power and Light Company's Oyster Creek Generating Station (OCGS) (Tatham et al. 1978). The station is located 3.2 km (2 miles) inland from Barnegat Bay in Ocean County, New Jersey.

The intake draws water from Barnegat Bay through an intake canal. The station's cooling water intake has a set of six trash racks with 6.5-cm (2.5-in.) clear spacing. Downstream of the trash racks are six vertical traveling screens fitted with 1-cm (0.4-in.) mesh. The intake has a cooling water system consisting of four circulating water pumps that can provide flows up to 28.9 m<sup>3</sup>/sec (1,020 cfs). The mean velocity in front of the trash racks with four circulating pumps and six traveling screens in operation varies from 0.17 to 0.22 m/sec (0.57 to 0.73 ft/sec).

Samples were collected from the sluiceway each week. Collections were conducted on three separate days (mostly during nighttime hrs) each week for a total of 48 hrs per week. The screens were washed at the beginning of each sampling period and every two hrs thereafter (sooner if there was a certain pressure differential across the screens). The sampler consisted of a 45.7 by 50.8 by 61.0 cm (18 by 20 by 24 in.) basket with 10.7-mm (0.42-in.) wire mesh. The sampler was placed in the sluiceway for approximately 1 min, after which the sampler was removed and organisms were placed on a sorting table. This process was repeated up to six times for each screenwash. Collected organisms were sorted by species and by condition. Live and damaged fishes were placed in a holding tank for 48-hr delayed mortality observation.

Sampling was conducted during the 20 months that OCGS operated, from September 1975 through August 1977. Collections of the greatest numbers of fish occurred in the spring and fall. The most commonly collected fish species included: bay anchovy (*Anchoa mitchilli*) (72% of total collected), Atlantic menhaden (*Brevoortia tyrannus*) (4%), spot (*Leiostomus xanthurus*) (4%), Atlantic silverside (*Menidia menidia*) (3.5%), smallmouth flounder (*Etopus microstomus*) (2.5%), and striped searobin (*Prionotus evolans*) (2%). Fishes with a greater than 70% initial survival rate included: Northern pipefish (*Syngnathus fuscus*) (90%), oyster toadfish (*Opsanus tau*) (85%) and fourspine stickleback (*Apeltes quadracus*) (85%; Table 3-9). Initial survival rates ranged from a high of 90% for Northern pipefish to a low of 7% for bay anchovy. A total of 39,042 fishes, 21,669 blue crabs, and 17,234 sand shrimp were collected during normal intermittent washes of the traveling screens. Few latent survival values were reported due to low numbers of test fish. Survival ranged from a high of 98% for striped searobin to a low of 5% for Atlantic menhaden (Table 2-35).

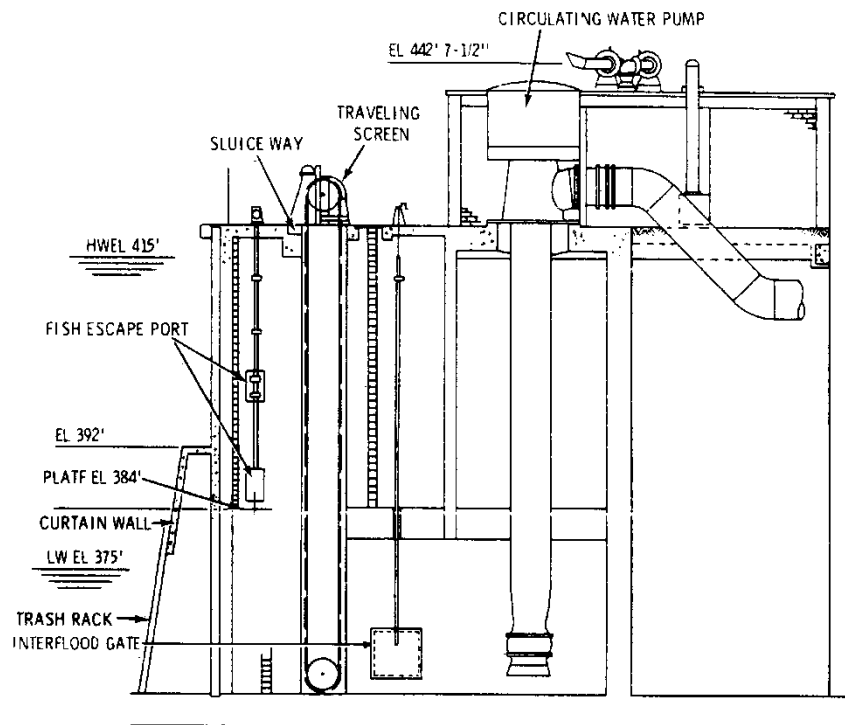
**Table 2-35**  
**Immediate and 48-hr survival of impinged fish and macroinvertebrates at Oyster Creek Generating Station (Tatham et al. 1978)**

| Species               | Immediate |        |           | Survival After 48 Hrs |        |        |
|-----------------------|-----------|--------|-----------|-----------------------|--------|--------|
|                       | Number    | % Live | % Damaged | % Dead                | Number | % Live |
| blueback herring      | 2,445     | 17     | 41        | 42                    |        |        |
| alewife               | 329       | 12     | 50        | 38                    |        |        |
| Atlantic menhaden     | 3,165     | 8      | 64        | 28                    | 38     | 5      |
| bay anchovy           | 13,854    | 7      | 15        | 78                    | 128    | 9      |
| oyster toadfish       | 186       | 85     | 9         | 6                     |        |        |
| striped cusk-eel      | 633       | 47     | 41        | 12                    |        |        |
| Atlantic silverside   | 5,133     | 34     | 28        | 38                    | 141    | 35     |
| fourspine stickleback | 92        | 85     | 10        | 5                     |        |        |
| Northern pipefish     | 2,417     | 90     | 5         | 5                     | 33     | 79     |
| black seabass         | 310       | 37     | 33        | 30                    |        |        |
| bluefish              | 433       | 20     | 21        | 59                    |        |        |
| weakfish              | 1,351     | 15     | 26        | 59                    |        |        |
| spot                  | 2,367     | 19     | 33        | 48                    |        |        |
| striped searobin      | 1,335     | 55     | 27        | 18                    | 45     | 98     |
| smallmouth flounder   | 2,213     | 36     | 38        | 26                    |        |        |
| summer flounder       | 259       | 53     | 38        | 9                     |        |        |
| winter flounder       | 686       | 46     | 39        | 15                    | 12     | 67     |
| grass shrimp          | 2,259     | 87     | 5         | 8                     |        |        |
| sand shrimp           | 17,234    | 77     | 9         | 14                    | 15     | 87     |
| blue crab             | 21,669    | 64     | 29        | 7                     | 149    | 79     |

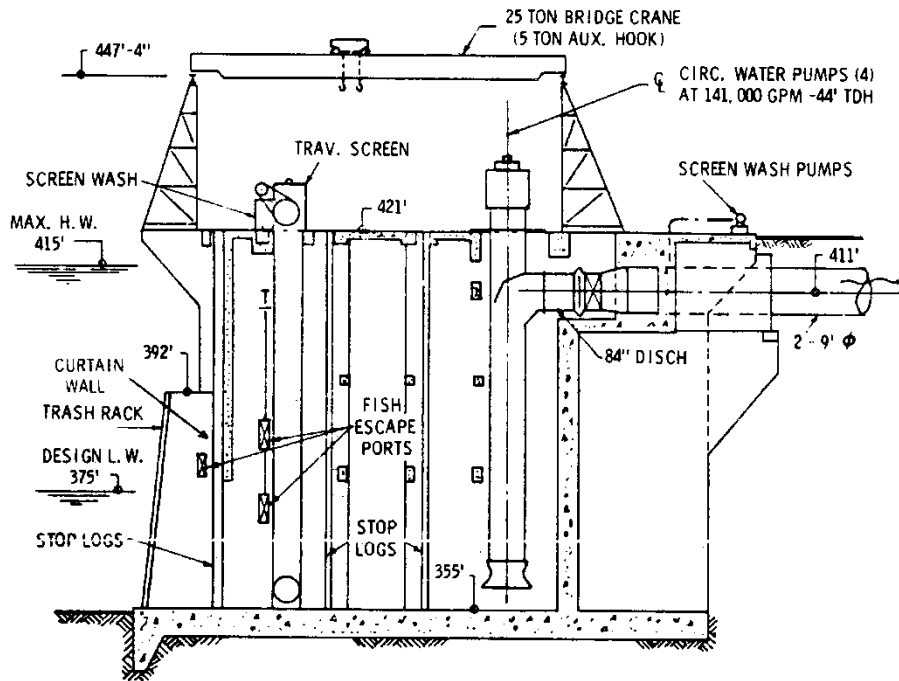
It appeared that the continuous operation of the traveling screens increased the immediate survival of Atlantic menhaden, Atlantic silverside, and winter flounder. The authors note that this conclusion is based on a limited number of specimens. The differences in survival were most dramatic for fishes that had low survival during the intermittent operation of the traveling screens. Overall, survival on the traveling screens was variable and was effected by the species, season, and size of individual impinged organisms.

### **Hanford Reservation**

A comparative fish impingement study was conducted between two adjacent water intakes on the U.S. Department of Energy's (U.S. DOE) Hanford Reservation (Page et al. 1977). The site is on the Columbia River between Priest's Rapids and McNary dams. The 100-N reactor and the Hanford Generating Project (HGP) were the two power generating stations where fish impingement studies were conducted. Impingement studies were carried out at HGP from March 1973 through April 1976 and at 100-N during 1977. Fish impingement was compared at the two intakes in 1977 (Figure 2-17 and Figure 2-18).



**Figure 2-17**  
**Section view of 100-N intake structure (Page et al. 1977)**



**Figure 2-18**  
**Section view of HGP intake structure (Page et al. 1977)**

Cooling water from the river is supplied to 100-N by four pumps with a total rated capacity of 26.4 m<sup>3</sup>/sec (936 cfs). The six pump bays are each fitted with a traveling screen. The intake at HGP also has four pumps but with a total capacity of 35.6 m<sup>3</sup>/sec (1,257 cfs). When river temperatures are less than 7.2° C (45° F), only three of the four pumps are operated. The intake has two pump bays with three traveling screens installed in each.

The traveling screens are made up of 3.1 by 0.6 m (10 by 2 ft) screen panels. The panels are fitted with screening material with 0.32-cm (1/8-in.) square openings. A curtain wall extends down in front of the screens to 116 m (380 ft) above sea level. The curtain wall is located behind a trash rack at HGP. At 100-N, the trash rack extends down from the curtain wall. Both intakes are equipped with a fish escapeway portal in the exterior downstream wall. Impinged organisms and debris are removed by a spraywash system. The washwater from the screens is carried to a sump pit where it is discharged back into the river through a 40.6-cm (16-in.) diameter pipe.

A sample pipe was installed at HGP to collect impinged organisms for the impingement studies. The system diverted approximately 25% of the washwater into a swimming pool for daily collections. At 100-N, a basket fitted with 0.32-cm (1/8-in.) mesh was installed in the sump pit. The basket sampled 100% of the screenwash water.

Previous impingement studies at HGP revealed that 90% of the fish impinged on the traveling screens were zero-age Chinook salmon (*Oncorhynchus tshawytscha*) under 50 mm (1.97 in.) in length. Highest months of impingement were April and May. The numbers of other fish impinged at the station were insignificant compared to those of Chinook salmon.

During the comparative study, the most frequently collected species were yellow perch (*Perca flavescens*) fry and Chinook salmon, with yellow perch fry 14 times more abundant than



Chinook salmon. A total of seven species was collected from the traveling screens at 100-N. All the fish collected from the basket at 100-N were dead. At HGP, a total of 10 species of fish was collected. The most commonly impinged fish at HGP was Chinook salmon fry. Almost equal numbers of Chinook and yellow perch were impinged at HGP. Survival rates for Chinook salmon and yellow perch fry were high, i.e., 97% and 92%, respectively. Other impinged species had similar survival rates. Compared to 100-N, twice as many yellow perch fry and 30 times as many Chinook salmon were collected from the screens at HGP.

The authors propose several explanations for the difference in impingement between the two adjacent plants, including plant location (upstream/downstream), intake location (forebay orientation), and intake configuration. Another explanation, involving a difference in the trash rack/curtain wall configuration, appeared to be the most plausible. Experimental releases conducted in the forebay of both plants indicated that HGP impinged three times more fish than 100-N. Additional releases of live and dead fish in front of the traveling screens revealed that HGP collected almost six times as many live fish as 100-N. Dead fish, however, were collected more frequently by 100-N. It was suggested that, based on these results, velocities at the screens appear to be higher at 100-N, but some behavioral stimuli may have induced live fish to avoid the screens.

### ***Surry Power Station***

Ristroph vertical traveling screens were installed at Surry Power Station and evaluated for their ability to provide safe removal of fish without compromising the cooling water operation of the plant (White and Brehmer 1977). Only initial survival studies were conducted during impingement evaluations. The station is located on Gravel Neck peninsula on the James River in Virginia about 46.3 km (28.8 miles) from the Chesapeake Bay. The station's two units each generate up to 788 MW each. The intake structure is 60.4 m (198 ft) long with trash racks in each of the eight forebays. The station flow rate is 111 m<sup>3</sup>/sec (3,920 cfs).

Each of the Ristroph screens at Surry Station contains 47 panels each 4.3 by 0.61 m (14 by 2 ft). The screen panels are fitted with 0.45-cm (0.2-in.) mesh and were operated continuously at 3 m/min (10 ft/min) during the test period. Debris and impinged organisms are removed from the screens by a backwash spray system, which operates at 15 to 20 psi. Materials are washed from the screens into a sluice and returned to the river. Minor modifications were made to the Ristroph screen system during the first few months of testing. An auxiliary spray wash system was installed to aid in removal of fish from the screens. Water volume was added to the river return trough to assist fish in their movement through the trough. Additionally, a neoprene flap was installed to prevent fish from falling between the screen and the trough when the screens were washed. A final step in the modifications was the installation of a system to slow the water velocity from the sluice into the sampling pool.

Daily sampling was conducted from May 1, 1974, through October 31, 1975. Two samples were collected consecutively from Monday through Friday of each week. Screen wash water was diverted into a fiberglass pool 8.5 by 6.1 by 1.2 m (28 by 20 by 4 ft). Sample duration was 5 min, after which water in the pool was allowed to settle for 10–15 min. Specimens in the tank were categorized by species and condition, and separated into 20 mm (0.79 in.) length ranges.

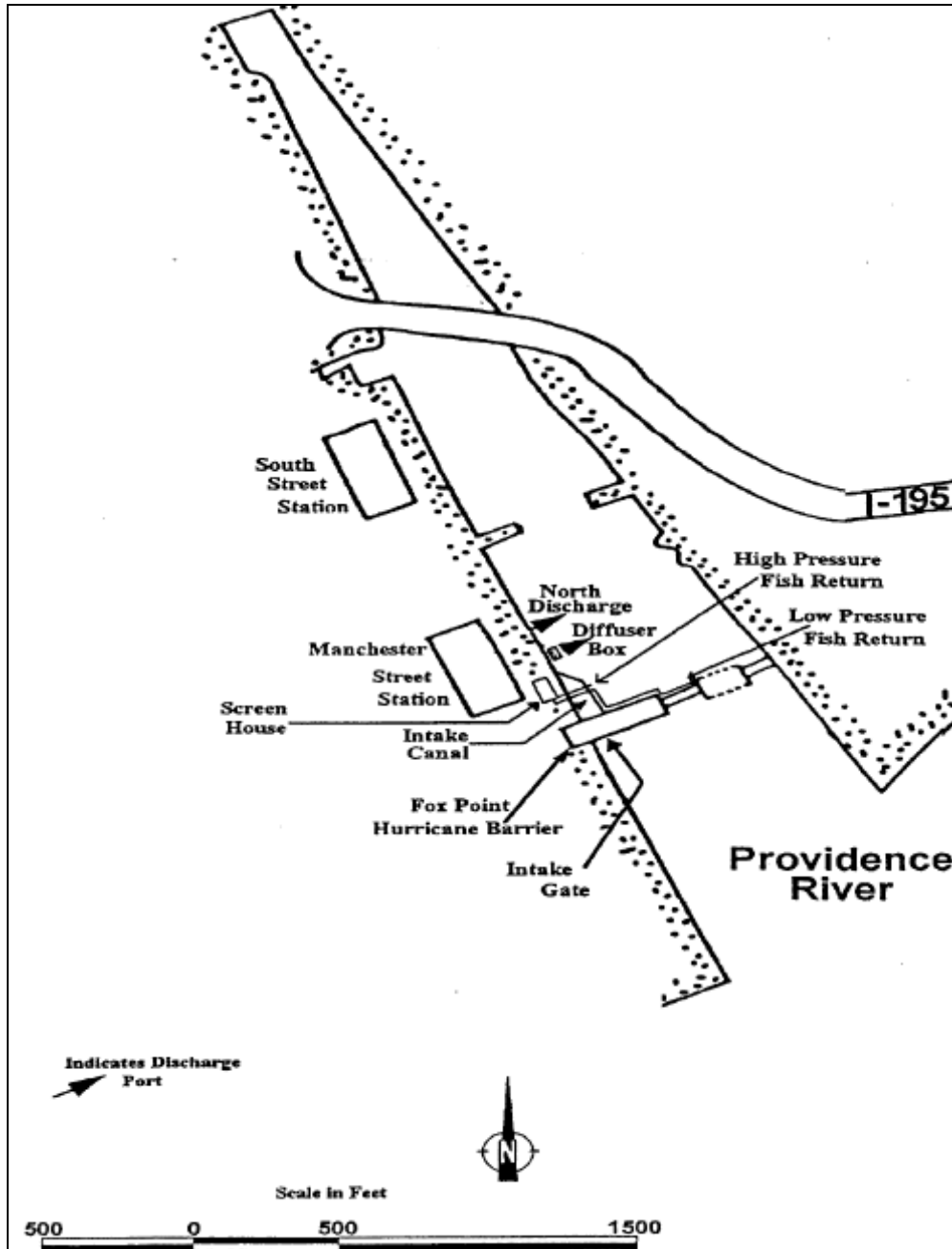
For the first 18 months of operation, average fish survival for all species was 93.3%. A total of 58 species of fish were collected from the Ristroph screens. Fifty-two of the 58 species had an

initial survival rate of greater than 80%, with the majority exhibiting survival rates greater than 90%. Species from the family Clupeidae made up 58.1% of the total fish collected from the screens during the study. The family Sciaenidae accounted for another 18.1% of the total fish sampled.

### ***Manchester Street Station***

The Manchester Street Station, located on the Providence River in Providence, R.I. was refurbished and repowered between 1992 and 1995 (Marine Research 1997). From October 1994 through July 1995, new continuously operating dual speed, 9.5-mm (3/8 in.) mesh Ristroph screens with high and low pressure washes were installed. This study assessed the survival for the Ristroph screens and the pressure wash systems.

Sampling efforts were conducted from January 1996 through March 1997. Samples were collected to collect the maximum sample size of fish and was reduced during periods of low impingement and increased during periods of high impingement. Samples were collected from three locations, the low-pressure return line at the screen house (LPN), the low pressure return line near the hurricane barrier (LPF), and the high pressure return line (HP) (Figure 2-19). The LPF and the HP collections were made in 1.2 by 1.2 m (4 by 4 ft) net pens with 6.4-mm (1/4-in.) mesh bags. Collections in 6.4-mm (1/4-in.) mesh nets affixed to the outlet of the LPN were used to make collections in that location. The LPF location was only assessable during low water periods 2 hrs per day because the outlet pipe was submerged and net pens could not be removed. Pens were checked every 10 – 15 min for samples. When collected, fish were gently removed using dip nets and scoops then immediately transferred to buckets containing ambient-temperature river water. Fish were then classified as live, dead, or injured. Live fish were transferred from buckets to 64.4-L (17-gal) fiberglass tanks supplied continuously with running river water for 48-hr holding periods. After the 48-hr holding period, fish were assessed for latent mortality.



**Figure 2-19**  
**Schematic of the Providence River showing Manchester Street Station and approximate location of high- and low-pressure fish return lines (Marine Research 1997)**

At total of 34 species were represented in this study, six species representing 86% of the sample. These species are presented in Table 2-36. The other 14% of the species were categorized as “others”. Threespine stickleback (*Gasterosteus aculeatus*) and winter flounder (*Pseudopleuronectes americanus*) exhibited high survival at the three sampling locations, having a combined 92% latent survival. Species sensitive to impingement, such as Atlantic menhaden (*Brevoortia tyrannus*), showed a low latent survival of less than 10%. Passage down the relatively long low pressure wash return line looked to increase mortality. Survival rates of this

study compared to studies conducted before the renovations have shown a meaningful improvement.

**Table 2-36**  
**Initial and 48-h survival rates by species. Results are from Marine Research (1997).**

| Species                | Initial Survival |       |       | Latent (48-h) Survival |       |       |
|------------------------|------------------|-------|-------|------------------------|-------|-------|
|                        | LPN              | LPF   | HP    | LPN                    | LPF   | HP    |
| Atlantic menhaden      | 81.8%            | 78.1% | 46.4% | 6.3%                   | 1.3%  | 2.4%  |
| winter flounder        | 98.2%            | 96.6% | 93.5% | 95%                    | 95.1% | 92.2% |
| Atlantic silverside    | 78.8%            | 76.9% | 50.4% | 38%                    | 28.2% | 17.3% |
| white perch            | 88.1%            | 55%   | 55.6% | 55.9%                  | 25%   | 33.3% |
| threespine stickleback | 100%             | 100%  | 100%  | 97.4%                  | 93.3% | 93.3% |
| Northern pipefish      | 100%             | 100%  | 100%  | 92%                    | 71.4% | 75%   |
| All others             | 82.9%            | 74.7% | 77.1% | 55.1%                  | 54.3% | 64.7% |

### **Millstone Nuclear Power Plant, Unit 3**

A monitoring study was conducted from May 1986 to October 1986 to evaluate the effectiveness of the fish return system, where weekly samples were collected simultaneously from the sluiceway and the debris troughs (NUSCO 1987). Fish collected alive in the sluiceway were held for 72 hrs to evaluate survival. Results are presented below.

The Unit 3 intake is divided into six bays and contains six circulating pumps, four service water pumps, and two screen wash pumps. The full flow capacity for the entire structure is about 56.6 m<sup>3</sup>/sec (1,998.8 cfs). Each bay in Unit 3 is equipped with a trash rack and a travelling screen. The trash racks are 4.9 m (16.1 ft) wide and consist of 1.3 by 8.9 cm (1/2 by 3.5 in.) vertical steel bars installed 6.4 cm (2.5 in.) apart at a slope of 5 to 1. Travelling screens consist of a band of screening panels 4.3 m by 0.61 m (14.1 by 2 ft) constructed of 4.8-mm (0.2-in.) mesh copper cloth. Rotation of the screen is dependent of water depth, automatically rotating when the difference in water depth is greater than 100 mm (3.9 in.). The screen is equipped with low pressure spray wash headers to flush organisms into a sluiceway and high pressure spray wash headers to flush debris and leftover organisms off into debris troughs, both directed back to the source water body.

A total of 3,355 specimens were collected, encompassing 55 species of fish and 15 species of macroinvertebrates, in 32 samples during the monitoring study. The total calculated return rate for organisms was 41%, 49% for the most abundant fish (10 species comprising 85%). Survival of the 10 most abundant fish species varied depending on demersal or pelagic body type (Table 2-37). High mortality in butterfish was most likely caused by the fragile nature of butterfish and impingement coinciding with large masses of jellyfish.

**Table 2-37**  
**Millstone Unit 3 sluiceway survival of the 10 most abundant species following various holding periods (NUSCO 1987).**

| Species                | Body Type Group (%) | Number Examined | (%) Initial Survival | (%) Survival at 6-hr | (%) Survival at 24-hr | (%) Survival at 72-hr |
|------------------------|---------------------|-----------------|----------------------|----------------------|-----------------------|-----------------------|
| Northern pipefish      | Demersal            | 210             | 95.2                 | 92.4                 | 91.4                  | 91.0                  |
| threespine stickleback | Demersal            | 74              | 73.0                 | 71.6                 | 71.6                  | 71.6                  |
| grubby                 | Demersal            | 34              | 100.0                | 100.0                | 100.0                 | 97.1                  |
| winter flounder        | Demersal            | 6               | 100.0                | 100.0                | 100.0                 | 100.0                 |
| butterfish             | Pelagic             | 87              | 16.1                 | 3.4                  | 3.4                   | 2.3                   |
| bay anchovy            | Pelagic             | 62              | 1.6                  | 0.0                  | 0.0                   | 0.0                   |
| Atlantic silverside    | Pelagic             | 68              | 22.1                 | 2.9                  | 1.5                   | 0.0                   |
| Atlantic menhaden      | Pelagic             | 54              | 0.0                  | 0.0                  | 0.0                   | 0.0                   |
| bluefish (juvenile)    | Pelagic             | 14              | 42.9                 | 7.1                  | 0.0                   | 0.0                   |

### **Scattergood Generating Station**

Post-impingement survival of a pilot-scale post impingement fish return program was evaluated at Scattergood Generating Station (SGS) in Los Angeles, California (Miller 2007). Assessment of the fish return system required collection of live fish from the traveling screens during heat treatments. Samples were collected during heat treatments to maximize the number of organisms collected. Critical Thermal Maxima during heat treatments was inferred based on analysis from San Onofre Nuclear Generating Station (SONGS).

During six routine monitoring of heat treatment at SGS from February 2005 to August 2006, live fish were collected by hand off the steel 9.5-mm (3/8-in.) square mesh screens which continuously rotated during heat treatments. Collections started at the beginning of the heat treatment and ended when the water temperature reached 35°C. Fish were then collected by hand from the traveling screen, stored in buckets filled with seawater and transported to SEA lab in Redondo Beach, CA, where they were held in holding tanks supplied with a continuous seawater flow. Health of the fish were observed every 24-hrs for 144-hrs, recording mortality per 24-hrs. Survival was calculated for species which had at least 100 individuals and cumulatively across all species.

Fifteen species made up 99% of the total sample (Table 2-38). Of the 101,122 fish collected, 464 (0.5%) were collected alive. Queenfish (*Seriphus politus*) were the most frequently collected species, followed by topsmelt (*Atherinops affinis*), white croaker (*Genyonemus*

*lineatus*), and walleye surfperch (*Hyperprosopon argenteum*). Three families (Embiotocidae, Atherinopsidae, and Sciaenidae) represented the majority of all impinged fish and all exhibited little to no survival.

Walleye surfperch were the most abundant species collected alive, followed by topsmelt, kelp bass (*Paralabrax clathratus*), bat ray (*Myliobatis californica*), and black perch (*Embiotoca jacksoni*). Of the 464 fish collected alive, 383 (82.5%) survived the holding period. Total survival for all fish held after impingement was 0.4%. The highest species-specific survival rates were for kelp bass, bat ray, spotted turbot (*Pleuronichthys ritteri*), and black perch. However, these species were impinged in relatively low numbers.

Fish impinged at SGS demonstrated extended survival of only 0.4% and was highly species specific. Of species with ten or more individuals held for extended mortality after impingement, only queenfish and eagle ray exhibited survival lower than 70%. All though a 144 hr holding period is particularly long, most mortality occurred within the first 24-hrs, decreasing dramatically after 72-hrs. There was no mention of held fish being fed which could have been a factor in latent survival. Critical thermal maxima were not determined at SGS, but temperatures over 29°C (84.2°F) seemed to incapacitate most species, doubling abundance of impinged fish after exceeding that temperature. Heat treatments were a major stressor in increasing overall mortality and may not reflect survival that could be achieved with travelling screens at west-coast power plants. These data might be more useful (in the absence of other data) in determining the relative heartiness of the individual species then and absolute survival estimate.

**Table 2-38**  
**Count and survival of fish impinged on the traveling screen at SGS (Miller 2007)**

| Species                 | Total Impingement | Live Collected | % Total Survival | % Survival of Held |
|-------------------------|-------------------|----------------|------------------|--------------------|
| queenfish               | 31,957            | 11             | 0.00%            | 9.10%              |
| topsmelt                | 5,525             | 48             | 0.80%            | 97.70%             |
| white croaker           | 4,380             | 26             | 0.50%            | 84.60%             |
| walleye surfperch       | 3,721             | 58             | 1.30%            | 86.20%             |
| jack                    | 930               | 26             | 2.40%            | 84.60%             |
| shiner perch            | 428               | 5              | 0.70%            | 60.00%             |
| neotropical silversides | 266               | 5              | 0.00%            | 0.00%              |
| black perch             | 175               | 30             | 15.40%           | 90.00%             |
| eagle ray               | 164               | 44             | 16.50%           | 61.40%             |
| white seaperch          | 158               | 1              | 0.00%            | 100%               |
| barred sand bass        | 156               | 14             | 8.30%            | 92.90%             |
| kelp bass               | 149               | 45             | 30.20%           | 100%               |
| blacksmith              | 131               | 7              | 5.30%            | 100%               |
| spotted turbot          | 100               | 21             | 16.00%           | 76.20%             |
| black croaker           | 91                | 7              | 6.60%            | 85.70%             |
| Other species           | 541               | 115            | 21.3%            | 83.6%              |

### **H. A. Wagner Generating Station**

A study evaluating the survival of impinged blue crab and finfish impinged at the H. A. Wagner Generating Station was conducted from January 1987 through January 1988 (Breitburg and Reiher 1988). The H. A. Wagner Generating Station is located on the Patapsco River in Baltimore, MD. Cooling water is withdrawn from the Patapsco River through two intake bays. The identical bays are equipped with 9.5-mm (3/8-in.) mesh travelling screens and trash racks with 9.5-mm by 10.2-cm (3/8 by 4-in.) flat bar spaced approximately 10.2-cm (4 in.) on-center. A high-pressure (85 psi) front spraywash is used to remove fish and debris from the screens (McMahon et al 2008). The objectives of this study were to estimate total impingement and impingement survival of blue crab and finfish.

Sampling was conducted at Units 1, 3, and 4 from 25 January 1987 through 24 January 1988. It was not possible to sample Units 1 and 3 for every month because of outages. Finfish and crabs were netted directly from fish return pipes, one located on each operating unit. A 1.27 cm stretch mesh net collecting net, 3-4 m long and supported by a 0.9 m diameter metal ring, were hung from the end of each pipe. Rotating screens were washed for 10 min/hr. During the 50 min between screen washes, nets were washed down and samples taken. Once collected, finfish and blue crab were identified, enumerated, and measured to size category. Live fish and blue crabs were held in separate holding cages and a 96-h survival study was conducted, observing survival every 24 hrs.

**Table 2-39**  
**Total number of the 15 most abundant species collected during impingement studies at H. A. Wagner Generating Station**

| Scientific Name                      | Common Name            | Total Collected |
|--------------------------------------|------------------------|-----------------|
| <i>Brevoortia tyrannus</i>           | Atlantic menhaden      | 34,709          |
| <i>Anchoa mitchilli</i>              | bay anchovy            | 13,782          |
| <i>Trinectes maculatus</i>           | hogchoker              | 12,219          |
| <i>Micropogonias undulatus</i>       | Atlantic croaker       | 10,926          |
| <i>Menidia spp.</i>                  | silversides            | 3,731           |
| <i>Alosa aestivalis</i>              | blueback herring       | 1,314           |
| <i>Gobiosox strumosus</i>            | skilletfish            | 840             |
| <i>Morone americana</i>              | white perch            | 541             |
| <i>Dorosoma cepedianum</i>           | gizzard shad           | 498             |
| <i>Fundulus majalis</i>              | striped killifish      | 471             |
| <i>Pseudopleuronectes americanus</i> | white flounder         | 451             |
| <i>Cynoscion nebulosus</i>           | spotted seatrout       | 432             |
| <i>Gasterosteus aculeatus</i>        | threespine stickleback | 421             |
| <i>Fundulus heteroclitus</i>         | mummichog              | 382             |
| <i>Syngnathus fuscus</i>             | Northern pipefish      | 345             |
|                                      | All Other Fish         | 1377            |
|                                      | <b>Total Collected</b> | <b>82,439</b>   |

Finfish impingement totaled 65,563 individuals. Fifteen species made up 98.3% of the sample. Atlantic menhaden dominated the total catch making up 45.5%. Finfish species were divided into two groups to represent survival; mid-water schooling species and other species (i.e. bottom feeders, bottom dwellers, solitary species and some schooling species). Mid-water species were found to have a 24-hr survival  $\leq 25\%$ , while other species were found to have a 24-hr survival of  $\geq 25\%$ . Difference between 24-hr survival and 96-hr survival differed from 0 to 0.21%.

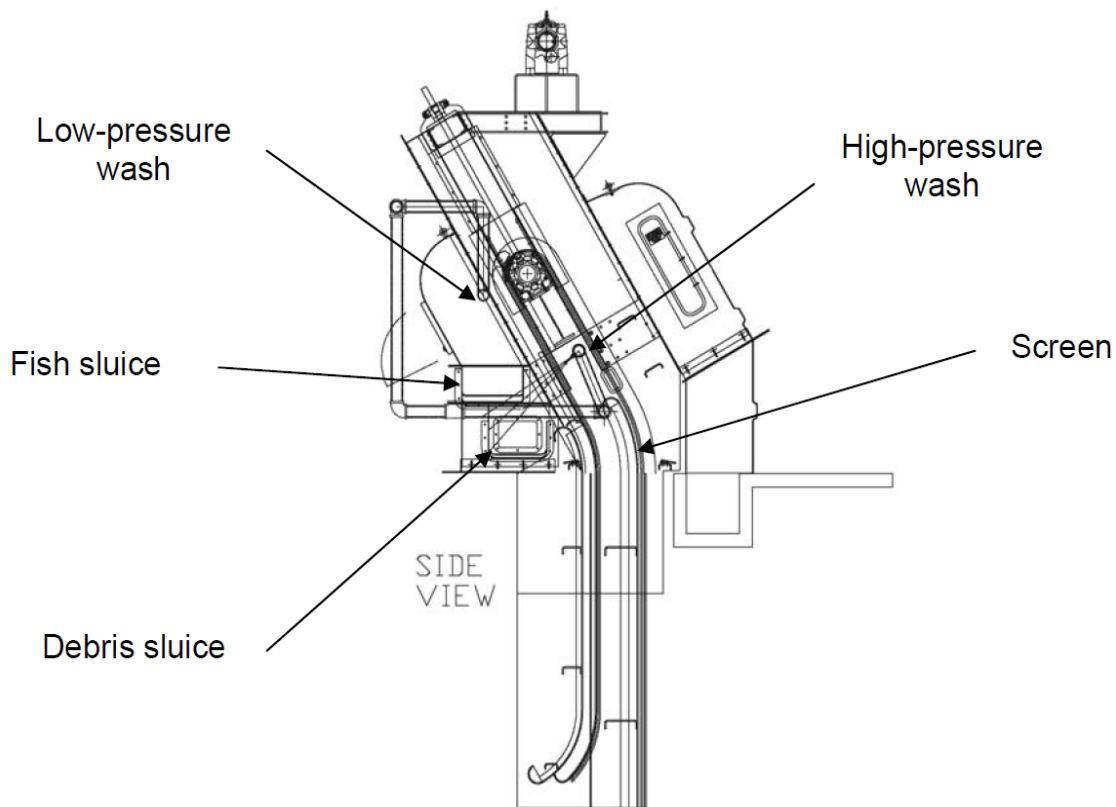
### ***E. F. Barrett Generating Station***

A full-scale performance evaluation of the Hydrolox screen was conducted at E. F. Barrett Generating station from October 2007 through June 2008 (ASA 2008).

E. F. Barrett is a two unit steam-electric generating power plant with a capacity of 350 MW. Cooling water is supplied by Barnum's Channel in Hempstead Bay through a non-contact once through cooling water system with an intake flow of 12.9 m<sup>3</sup>/sec (446 cfs). Unit 2 is screened by trash racks, a curtain wall, and coarse screens and consisted of two 4.3 m (14 ft). wide intake bays. Each intake bay is equipped with conventional vertical traveling screens with 0.64 by 2.5 cm (0.25 by 1.0 in.) vertical openings, and smooth-top mesh screen panels.

The study was conducted at the Unit 2 intake bays, one bay equipped with a Hydrolox screen and the other equipped with a conventional vertical travelling screen. The collection system was comprised of three devices, transitioning through the fish return system. Organisms and debris impinged on the screens were first collected in an aluminum collection bucket with 0.79-cm (0.31-in.) mesh drains, inserted in the fish sluice. A custom-fitted 0.64-cm (0.25-in.) soft net was installed behind the fish sluice, in the Hydrolox debris sluice, and locked into place at the transition between the stainless sluice and the concrete below deck sluice. A standard collection basket for the convention travelling screen modified with an aluminum insert to hold 10.2 cm (4 in.) of water was the final collection device in the system.





**Figure 2-20**  
**Hydrolox™ screen installed at the Barrett Generating Station, 2007**

Sampling was conducted weekly unless plant operations or lack of fish did not permit collections. Both screens were operated continuously on each sampling date and collections were made during 8-hr periods from 2000 to 0400, the times in which highest impingement occurred based on previous monitoring studies. Prior to sampling, all sluices were checked for and cleaned of debris. Collection devices were installed and monitored at intervals no greater than an hr. Fish were collected, removed, and classified as live, stunned, or dead. All live and stunned fish were placed into 18.9-L (5-gal) holding containers then transferred into 1,324.9-L (350-gal) holding tanks supplied with continuous flow from the Unit 2 intake header. Fish were retained and evaluated for 48-hr mortality. Species with less than 20 individuals collected were considered unreliable for developing survival estimates.

During the course of this study, a total of 3,697 fish comprising 33 species were collected; 2,956 from the Hydrolox screen fish sluice and 741 from the conventional vertical travelling screen. No fish were collected in the Hydrolox debris sluice, demonstrating the effectiveness of the system at removing fish in the fish trough. Most fish collected were relatively small and likely to be less than a year old. As illustrated in Table 2-40, ten species were collected in sufficient numbers from the Hydrolox screen. Seven of these species demonstrated survival rates greater than 98%. However, Atlantic menhaden (*Brevoortia tyrannus*) exhibited low survival. Only three species were collected in sufficient numbers from the conventional vertical travelling screens. Mummichog (*Fundulus heteroclitus*) exhibited high survival that was comparable to the Hydrolox screen. Atlantic silverside (*Menidia menidia*) showed a substantial decrease in survival

compared to the Hydrolox screen. Atlantic menhaden exhibited no survival on the conventional travelling screen which was comparable to the low survival exhibited on the Hydrolox screen.

**Table 2-40**

**48-hr mortality by species, number of species collected, and size range by species. Blanks indicate species collected in insufficient numbers for reliable for latent survival estimates. Results are from ASA (2008).**

| Species             | Number Collected | Hydrolox Screen      |                                | Conventional Vertical Travelling Screen |                      |                                |
|---------------------|------------------|----------------------|--------------------------------|-----------------------------------------|----------------------|--------------------------------|
|                     |                  | Length Range (TL mm) | Estimated Impingement Survival | Number Collected                        | Length Range (TL mm) | Estimated Impingement Survival |
| Atlantic silverside | 1,605            | 49-123               | 60.3%                          | 531                                     | 47-119               | 7.5%                           |
| mummichog           | 546              | 34-97                | 99.4%                          | 101                                     | 42-84                | 96.4%                          |
| Atlantic menhaden   | 195              | 40-112               | 6.8%                           | 45                                      | 52-349               | 0%                             |
| Northern pipefish   | 122              | 73-213               | 98.3%                          | --                                      | --                   | --                             |
| seaboard goby       | 115              | 38-61                | 100%                           | --                                      | --                   | --                             |
| striped killifish   | 90               | 41-100               | 100%                           | --                                      | --                   | --                             |
| grubby              | 59               | 54-109               | 100%                           | --                                      | --                   | --                             |
| american sand lance | 41               | 102-165              | 70.7%                          | --                                      | --                   | --                             |
| tautog              | 39               | 46-205               | 100%                           | --                                      | --                   | --                             |
| winter flounder     | 39               | 48-287               | 100%                           | --                                      | --                   | --                             |

### ***Hudson Generating Station***

A full-scale performance evaluation of modified coarse-mesh Ristroph-type travelling screens was conducted at PSEG’s Hudson Generating Station from January 2009 to December 2010 (ASA 2011). Two Ristroph-type screens were installed on Unit 2 in 2008. The screens measure approximately 3.4 by 13.4 m (11 by 44 ft) and were fitted to existing screenbays. Coarse-mesh screen panels are comprised of 0.2-cm (0.080-in) stainless steel wire mesh with 0.64 by 1.27-cm (¼ by ½-in.) openings. Fish baskets equipped with Fletcher-design flow spoilers are located at the bottom of each screen panel. The screen is equipped with two low pressure (7 psi and 15 psi) water jets to remove fish and a high pressure (80 psi) to remove debris.

The Hudson Generating Station is located on the Hackensack River in Jersey City, New Jersey. The station consists of two fossil-fired steam electric generating units with a combined net rating of 983 MW during summer months. Units 1 and 2 withdraw water from the Hackensack River through once-through cooling water systems. Each unit is comprised of two intake bays and equipped with two water pumps and two service water pumps. Each intake bay consists of stainless steel trash racks with 7.6-cm (3-in.) openings and concrete skimmer walls. Unit 1 is equipped with two conventional travelling water screens with screen panels comprised of 2.0-mm (0.08-in.) stainless steel mesh with 0.64 by 1.27-cm (1/4 by 1/2-in.) openings. The rated water intake at full capacity is 39.1 m<sup>3</sup>/sec (1,381.4 cfs).

A two-year study was conducted to estimate impingement losses at Unit 2. The study spanned from January 26, 2009 through January 17, 2011. Sampling was conducted one day per week at four 6-hr intervals, totaling 104 sampling events. Two 1-hr samples were taken during the first

two daily intervals while only one sample was taken during the last two intervals. Samples were collected from a fish collection pool attached to the fish return sluice of Unit 2.

Sample collections were initiated by opening the collection pool gate and closing off the fish return sluice. During the collection, the collection pool was monitored for over flow. After the 1-hr collection, the collection pool gate was closed and the fish return sluice was opened. Fishes and crabs were concentrated in the collection pool using a screen and removed. Once collected, organisms were identified to the lowest possible taxon and their condition was recorded as live, dead, or stunned. No more than 50 individuals per species were weighed and measured. If collected at sufficient numbers ( $\geq 20$ ), fish were held for 48-hr latent mortality evaluations in 18.9-L (5-gal) holding containers, separated by collection interval. No more than 100 fish per species were held for a collection date. Latent mortality was observed every 24-hrs.

During the course of the study, a total of 5,079 fish encompassing 56 species and one genus (Morone) were held for latent mortality evaluations. Average initial survival for all combined species was 92%. After 48 hrs, average survival of all fish collected was 57% and average extended survival of all fish held was 62%.

| Common Name              | Total Number Collected | Percent Survival |              |              | Total 48 hr Confidence Interval |
|--------------------------|------------------------|------------------|--------------|--------------|---------------------------------|
|                          |                        | Initial          | Extended     | Total 48 hr  |                                 |
| white perch              | 1,288                  | 95.6%            | 85.0%        | 81.2%        | 79.0% - 83.3%                   |
| bay anchovy              | 1,226                  | 86.7%            | 13.4%        | 11.6%        | 9.8% - 13.5%                    |
| spotted hake             | 658                    | 84.3%            | 74.8%        | 63.1%        | 53.3% - 66.8%                   |
| Atlantic silverside      | 406                    | 99.3%            | 80.4%        | 79.8%        | 75.6% - 83.6%                   |
| red hake                 | 188                    | 98.9%            | 90.3%        | 89.4%        | 84.1% - 93.4%                   |
| threespine stickleback   | 149                    | 99.3%            | 99.3%        | 98.7%        | 95.2% - 99.8%                   |
| oyster toadfish          | 128                    | 98.4%            | 88.9%        | 87.5%        | 80.5% - 92.7%                   |
| winter flounder          | 125                    | 94.4%            | 76.3%        | 72.0%        | 63.3% - 79.7%                   |
| alewife                  | 117                    | 90.6%            | 47.2%        | 42.7%        | 33.6% - 52.2%                   |
| silver hake              | 107                    | 95.3%            | 35.3%        | 33.6%        | 24.8% - 43.4%                   |
| blueback herring         | 100                    | 98.0%            | 29.6%        | 29.0%        | 20.4% - 38.9%                   |
| lookdown                 | 70                     | 92.9%            | 33.8%        | 31.4%        | 20.9% - 43.6%                   |
| gizzard shad             | 64                     | 95.3%            | 37.7%        | 35.9%        | 24.3% - 48.9%                   |
| bluefish                 | 56                     | 73.2%            | 29.3%        | 21.4%        | 11.6% - 34.4%                   |
| Atlantic tomcod          | 53                     | 100.0%           | 77.4%        | 77.4%        | 63.8% - 87.7%                   |
| American eel             | 52                     | 98.1%            | 76.5%        | 75.0%        | 61.1% - 86.0%                   |
| hogchoker                | 37                     | 91.9%            | 88.2%        | 81.1%        | 64.9% - 92.0%                   |
| Atlantic menhaden        | 32                     | 87.5%            | 32.1%        | 28.1%        | 13.8% - 46.8%                   |
| striped bass             | 24                     | 100.0%           | 83.3%        | 83.3%        | 62.6% - 95.3%                   |
| Weakfish                 | 23                     | 95.7%            | 59.1%        | 56.5%        | 34.5% - 76.8%                   |
| bluegill                 | 20                     | 90.0%            | 94.4%        | 85.0%        | 62.1% - 96.8%                   |
| butterfish               | 20                     | 95.0%            | 5.3%         | 5.0%         | 0.1% - 24.5%                    |
| All other species        | 136                    | 94.1%            | 72.7%        | 68.4%        | 59.9% - 76.1%                   |
| <b>All fish combined</b> | <b>5,079</b>           | <b>92.1%</b>     | <b>61.5%</b> | <b>56.7%</b> | <b>55.3% - 58.1%</b>            |

## Potomac Generating Station

The Electric Power Research Institute (EPRI) sponsored a field study to evaluate the injury and survival of fish exposed to a Geiger Multi-Disc™ (Geiger) modified traveling water screen. A complete description of Geiger screens is provided in the introduction to this chapter. The study was conducted at the Potomac River Generating Station in Virginia. The objectives of this evaluation were to identify species-specific variations in fish survival; to document the type and frequency of injury to fish that may occur following removal from a modified Geiger screen; and to investigate the debris handling capabilities of the Geiger screen (Figure 2-21; Figure 2-22).

MULTIDISC SCREEN Typical Assembly Drawing

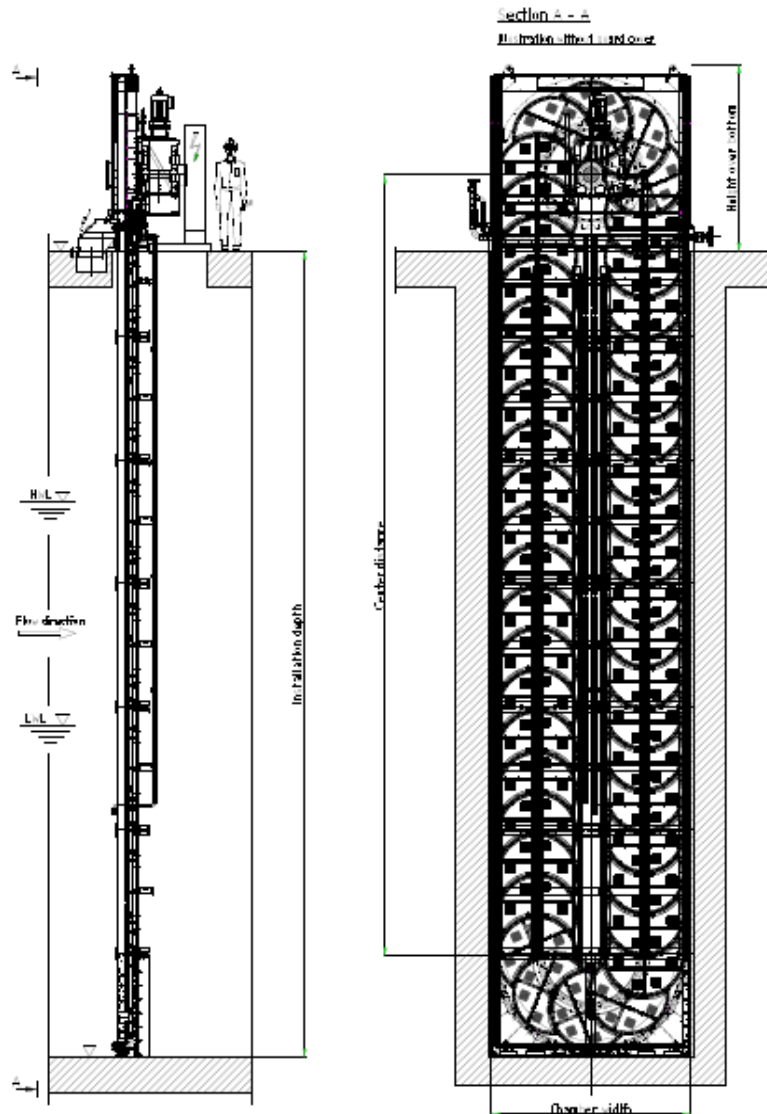
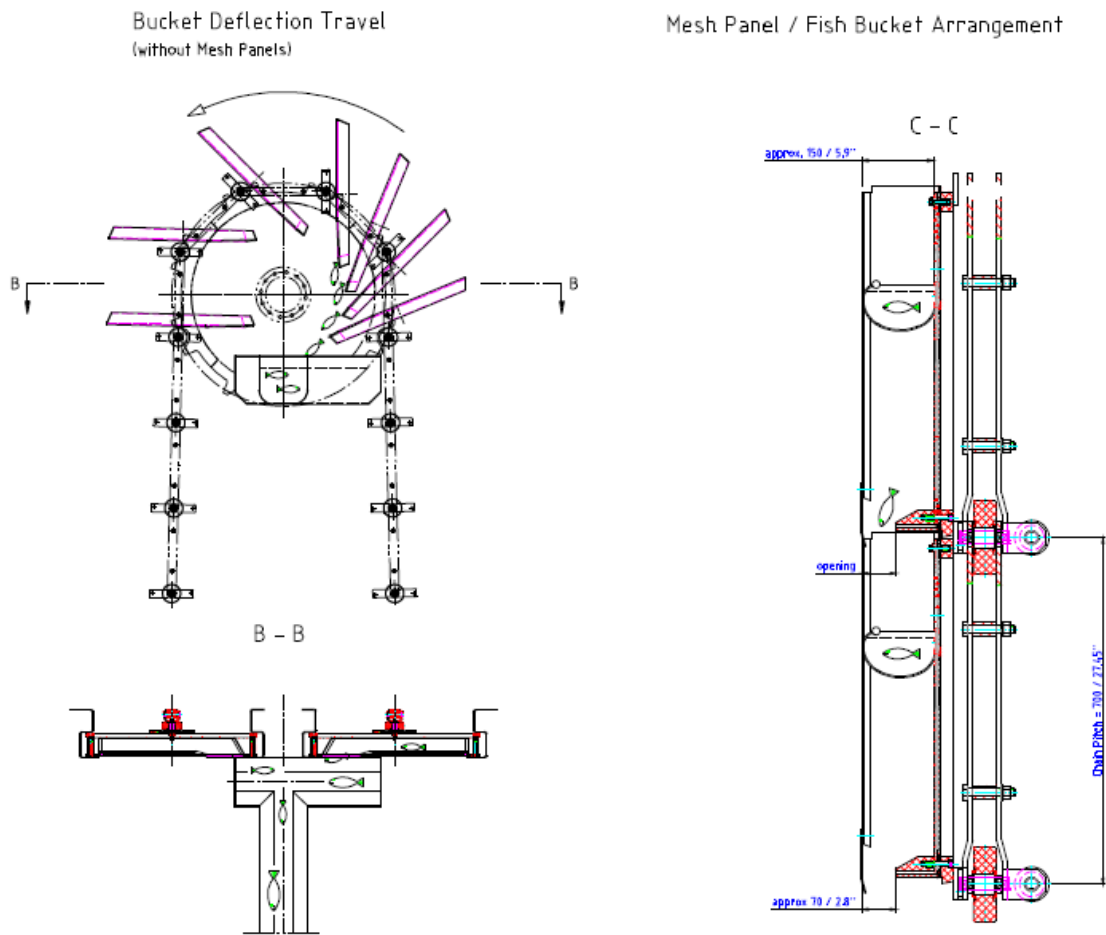


Figure 2-21  
Passavant-Geiger Multi-Disc™ Screen



**Figure 2-22**  
**Passavant-Geiger fish collection details**

Two conventional traveling water screens at the CWIS were replaced with two Geiger screens for this evaluation. Approach velocities at the screen faces were between 0.15 and 0.18 m/sec (0.5 and 0.6 ft/sec). The Geiger screens were composed of 9.5-mm (3/8-in) drilled plastic. One of the screens had fish buckets designed to collect impinged fish and transfer them to a fish return system. This screen was also outfitted with a low pressure (5 psi) spraywash system to aid in the transfer of fish to the return trough. This screen, which was designed to collect and return impinged fish, was the one evaluated during this study.

An angled diversion was placed in the return system discharge trough to divert wash water and impinged organisms to a collection basket. Fish were collected from the basket and were either immediately processed or held for the 48-hr latent impingement mortality (LIM) assessment.

There were four sampling periods during 2005-2006; a spring, summer, and two fall seasonal periods. Each seasonal period was made up of several sampling events (each with a duration of approximately 8 hrs) which together comprised a total of 73 collection days. A sampling event consisted of consecutive collection days followed by 24- and 48-hr LIM observation periods.

The modified Geiger screen was rotated continuously at 16 ft/min during each sampling event (EPRI 2007).

Fish and debris were collected at 15 min, 30 min, or 1-hr intervals depending on fish density. Live fish were separated from debris and placed in LIM holding tanks. A maximum of 80 to 100 fish were held per tank. Dead fish were measured, weighed, assessed for injury, and identified to the lowest possible taxon. Injury assessment included both visible injuries and scale loss.

All collected fish were classified into one of five categories: 1) released live (not held due to size or other constraints); 2) immediate (initial) mortality/dead at collection, 3) dead at 24-hr observation, 4) dead at 48-hr observation, 5) live at 48-hr observation (EPRI 2007).

A total of 2,124 fish (2,097 assessed for LIM) were collected during the 2005 sampling efforts (Table 2-41). The most abundant species collected included white perch (*Morone americanus*) (50%), bluegill (*Lepomis macrochirus*) (27%), and spottail shiner (*Notropis hudsonius*) (12%). Four channel catfish (*Ictalurus punctatus*) and one gizzard shad (*Dorosoma cepedianum*) too large for the holding tanks were released alive after being measured, weighed, and assessed for injury. Over 95% of the fish collected during the study were collected during the December sampling event. December sampling coincided with a storm event (EPRI 2007).

A total of 988 fish (933 assessed for LIM) were collected during the 2006 sampling efforts. As in 2005, peak collections coincided with a major storm event in late June. The most abundant species collected were white perch (80%), American shad (*Alosa sapidissima*) (8%), and spottail shiner (4%). Two channel catfish and one brown bullhead (*Ameiurus nebulosus*) too large for the holding tanks were released alive after being measured, weighed, and assessed for injury.

White perch dominated the catch throughout the study. The white perch collected in fall 2005 had a mean length of 68.8 mm (2.7 in.) and mean weight of 5.7 g. Five percent of the fish assessed were injured with the major injury being bruising. Scale loss was minimal. In contrast, white perch caught in spring 2006 were smaller with a mean length of 44.1 mm (1.7 in.) and a mean weight of 3.3 g. Less than five percent of these fish were found to have any visible injury. Scale loss among white perch was <3% for 88% of the total catch.

For spottail shiner, only a small percentage of the total collected was injured. However, scale loss was relatively high; 60% of the catch had >3% scale loss. The only other species that showed any injury was channel catfish with 11% injured (primarily bruising) (EPRI 2007).

Individual species' survival varied from 0 to 100%; survival of species collected in significant numbers in 2005 and 2006, respectively, included bluegill (95 and 100%), channel catfish (94 and 50%), spottail shiner (95 and 54%), and white perch (56 and 30%) (Table 2-41). The authors concluded that although relatively few fish were collected during this evaluation, the Geiger screen performed well. Survival of the most abundantly impinged fish at the Potomac River Generating Station compared favorably to survival recorded at other facilities with modified traveling screens (Table 2-42). In addition, the debris handling capability of the screen was deemed acceptable (EPRI 2007).

**Table 2-41**  
**Total collected and percent survival by species sampled during 2005-2006 at the Potomac River**  
**Generating Station (EPRI 2007).**

| Species                                                    | Total Collected |      | Percent Survival |      |
|------------------------------------------------------------|-----------------|------|------------------|------|
|                                                            | 2005            | 2006 | 2005             | 2006 |
| American eel ( <i>Anguilla rostrata</i> )                  | 3               | 4    | 100              | 100  |
| American shad ( <i>Alosa sapidissima</i> )                 | 15              | 82   | 0                | 0    |
| Atlantic silverside ( <i>Menidia menidia</i> )             | 1               | 0    | 0                | n/a  |
| banded killifish ( <i>Fundulus diaphanus</i> )             | 17              | 0    | 94               | n/a  |
| bay anchovy ( <i>Anchoa mitchilli</i> )                    | 1               | 0    | 0                | n/a  |
| black crappie ( <i>Pomoxis nigromaculatus</i> )            | 1               | 0    | 100              | n/a  |
| bluegill ( <i>Lepomis macrochirus</i> )                    | 577             | 14   | 95               | 100  |
| brown bullhead ( <i>Ameiurus nebulosus</i> )               | 5               | 3    | 100              | 100  |
| common carp ( <i>Cyprinus carpio</i> )                     | 5               | 0    | 100              | n/a  |
| channel catfish ( <i>Ictalurus punctatus</i> )             | 114             | 8    | 94               | 50   |
| gizzard shad ( <i>Dorosoma cepedianum</i> )                | 6               | 1    | 50               | 0    |
| golden redhorse ( <i>Moxostoma erythrurum</i> )            | 1               | 4    | 100              | 100  |
| largemouth bass ( <i>Micropterus salmoides</i> )           | 3               | 2    | 100              | 100  |
| pumpkinseed ( <i>Lepomis gibbosus</i> )                    | 5               | 21   | 100              | 90.5 |
| spottail shiner ( <i>Notropis hudsonius</i> )              | 263             | 35   | 95               | 54.3 |
| tessellated darter ( <i>Etheostoma olmstedi</i> )          | 3               | 9    | 100              | 100  |
| white crappie ( <i>Pomoxis annularis</i> )                 | 1               | 0    | 100              | n/a  |
| white perch ( <i>Morone americanus</i> )                   | 1,039           | 748  | 56               | 30   |
| winter flounder<br>( <i>Pseudopleuronectes americana</i> ) | 0               | 1    | n/a              | 100  |
| yellow perch ( <i>Perca flavescens</i> )                   | 37              | 1    | 100              | 100  |



**Table 2-42**

**LIM survival percentages for the fall and spring season's most common species sampled at the Potomac River Generating Station and five other plants with modified traveling water screens (EPRI 2007).**

| Plant                     | FALL         |               |                  |          |              |             |                 |             |              | SPRING       |               |          |              |             |                 |             |              |
|---------------------------|--------------|---------------|------------------|----------|--------------|-------------|-----------------|-------------|--------------|--------------|---------------|----------|--------------|-------------|-----------------|-------------|--------------|
|                           | American eel | American shad | banded killifish | bluegill | gizzard shad | pumpkinseed | spottail shiner | white perch | yellow perch | American eel | American shad | bluegill | gizzard shad | pumpkinseed | spottail shiner | white perch | yellow perch |
| Potomac River             | 100          | 0             | 94               | 95       | 50           | 100         | 95              | 56          | 100          | 100          | 0             | 100      | 0            | 91          | 54              | 30          | 100          |
| Indian Point <sup>1</sup> | 80           | 65            | 97               | 93       |              | 74          | 50              | 60          |              |              |               |          |              |             |                 |             |              |
| Huntley <sup>2</sup>      |              |               |                  |          | 97           |             |                 |             |              |              |               |          | 5            |             | 98              |             | 100          |
| Somerset <sup>3</sup>     |              |               |                  |          | 64           |             | 100             | 86          |              |              |               |          | 65           |             | 95              | 72          | 81           |
| Salem <sup>4</sup>        |              |               |                  |          |              |             |                 | 96          |              |              |               |          |              |             |                 | 86          |              |
| Arthur Kill <sup>5</sup>  |              |               |                  |          |              |             |                 |             |              |              | 78            |          |              |             |                 | 88          |              |

1. Fletcher, R. I. 1990. Flow Dynamics and Fish Recovery Experiments: Water Intake Systems. Transactions of the American Fisheries Society. 119:393-415.
2. Beak 2000b. Post-Impingement Fish Survival at Huntley Steam Station, Winter and Fall 1999, Final Report. Prepared for Niagara Mohawk Power Corporation.
3. Public Service Enterprise Group (PSEG). 2004. Special Study Report, Salem Generating Station, Estimated Latent Impingement Mortality Rates: Updated Pooled Estimates Using Data From 1995, 1997, 1998, 2000, and 2003. Prepared for PSEG by Allee, King, Rosen, and Fleming, 7250 Parkway Drive, Suite 210, Hanover, MD 21076. June 18, 2004.
4. McLaren, J.B. and L.R. Tuttle. 2000. Fish Survival on Fine Mesh Traveling Screens. Environmental Science and Policy, Vol. 3, Supplement 1, 2000.
5. Consolidated Edison. 1996. Arthur Kill Generating Station Diagnostic Study and Post-Impingement Viability Substudy Report. Pursuant to December 23, 1993 Order of Consent. DEC File Number R2-2985-9004.

### **Fort Calhoun Station**

A full-scale performance evaluation of the Passavant-Geiger Multi-disc (Geiger) screen was conducted at Fort Calhoun Station from July to December 2010. Fort Calhoun is a 492 MW nuclear powered generation station located on the Missouri River in Blair, Nebraska. The station uses a once-through cooling water system which draws water from the river. The CWIS is comprised of six intake bays and three circulating water pumps with a total capacity of 22.7 m<sup>3</sup>/sec (802.1 cfs). Each pump draws water through two intake bays. Each intake bay is equipped with a vertical trash rack with 7.62 cm (3-in.) openings, a sluice gate, and a traveling screen.

Omaha Public Power District installed the Geiger screen on all six intake bays at Fort Calhoun Station. The Geiger screen, unlike conventional traveling screens, moves up and down on one plane, eliminating debris carryover from overtopping (Figure 2-23). The main components of the Geiger screen are the sickle-shaped mesh panels, one central chain guide-way integrated in the supporting structure, one revolving chain, one lower guide, low-pressure and high-pressure spraywashes, debris/fish buckets, a debris/fish collection/return trough, a drive unit, and a splash guard. The round screen opens are 9.5 mm (3/8 in.) in diameter and are arranged in a hex pattern.



**Figure 2-23**  
**Image of Geiger screen installed at Fort Calhoun Station**

Six, 24-hr sampling events occurred monthly for the duration of the study. Fish collected off the screens were diverted to a 189.3-L (50-gal) collection tank via a 6-in. diameter pipe. The

collection tank was continuously monitored and larger fish were immediately removed upon observation.

Approximately every 15 min, all organisms in the collection tank were removed. Organism were separated by species and held in a flow through system with water from the Missouri River. If 20 or less organisms were collected during a sampling event, all would be measured to total length and weighted. If there were more than 20 fish, they were divided into three separate size classes; young of the year, medium (juveniles and small adults), and large (large adults). Twenty individuals were selected randomly from each size group then weighed and measured. The remainder of the sample was counted and batch weighed. Fish were identified as live, dead, long dead, or moribund and physical conditions were classified as healthy, slightly damaged, or severely damaged. Fish identified as long dead and moribund were not used in the study. All live fish were released into the Missouri River after workup. Only initial survival was measured due to high water conditions. Most latent mortality studies hold fish for 24 to 48 hrs.

A total of 2,192 fish were collected during the six month study. Common carp was collected in the highest abundance, comprising of 44.9% of total collected fish. Initial survival estimates included 2,152 fish, 40 fish classified as either moribund or long dead. Overall, initial survival was high averaging 96.5% for all species (Table 2-43). Fish exhibited survival greater than 93.0% for all months except for September, which could be contributed to low sample size.

**Table 2-43**  
**Initial survival and number of individuals included in survival estimates by species for monitoring at Fort Calhoun Station (EA 2011)**

| Scientific Name                | Species         | No. Included in Survival Estimates | Total Survival |
|--------------------------------|-----------------|------------------------------------|----------------|
| <i>Cyprinus carpio</i>         | common carp     | 977                                | 97.90%         |
| <i>Dorosoma cepedianum</i>     | gizzard shad    | 382                                | 99.20%         |
| <i>Aplodinotus grunniens</i>   | freshwater drum | 208                                | 95.20%         |
| <i>Lepomis macrochirus</i>     | bluegill        | 185                                | 86.50%         |
| <i>Ictalurus punctatus</i>     | channel catfish | 60                                 | 96.70%         |
| <i>Osmerus mordax</i>          | rainbow smelt   | 56                                 | 87.50%         |
| <i>Ameiurus melas</i>          | black bullhead  | 46                                 | 97.80%         |
| <i>Pimephales promelas</i>     | fathead minnow  | 40                                 | 95.00%         |
| <i>Macrhybopsis storeriana</i> | silver chub     | 33                                 | 100.00%        |
| <i>Lepomis cyanellus</i>       | green sunfish   | 29                                 | 96.60%         |

| Scientific Name                | Species           | No. Included in Survival Estimates | Total Survival |
|--------------------------------|-------------------|------------------------------------|----------------|
| <i>Morone chrysops</i>         | white bass        | 25                                 | 100.00%        |
| <i>Lepisosteus platostomus</i> | shortnose gar     | 19                                 | 100.00%        |
| <i>Ictiobus sp.</i>            | buffalo           | 13                                 | 100.00%        |
| <i>Pylodictis olivaris</i>     | flathead catfish  | 10                                 | 80.00%         |
| <i>Notropis stramineus</i>     | sand shiner       | 10                                 | 100.00%        |
|                                | All Other Species | 66                                 | 97.00%         |
| <b>Total</b>                   |                   | <b>2,159</b>                       | <b>96.50%</b>  |

### **North Omaha Station**

Impingement survival studies were conducted at North Omaha Station to investigate the effectiveness of the Beaudrey Water Intake Protection (WIP) screen (EPRI 2009a; Bigbee et al 2010).

The North Omaha Station is a five unit coal-fired generating station located on the Missouri River in Omaha, Nebraska. The station has a total combined capacity of 663 MW. Thirteen circulating pumps draw cooling water from Missouri River through 16 travelling screens. The combined intake flow is 32 m<sup>3</sup>/sec (1,130 cfs).

In August 2006, the Beaudrey WIP screen with 6.1-mm (0.24-in.) square mesh replaced one of the six travelling at Intake No. 3. The screens are designed to rotate continuously at approximately two rotations per min, limiting the maximum impingement time to 30 seconds. Fish impinged on the WIP are transport organisms and debris to a return trough via a fish friendly pump, thus eliminating the potential injury and mortality associated with the air and spray wash exposure of traditionally screens.

Impingement collections were conducted during spring (April 28-May 2) and a summer (August 11th-15th) events. Hatchery fish, which included bluegill (*Lepomis macrochirus*), channel catfish (*Ictalurus punctatus*), and fathead minnow (*Pimephales promelas*), were delivered to the site and were allowed 48-hrs to acclimate to ambient Missouri River water. During the summer event, native fish collected were allowed to acclimate for 24-hrs. After acclimation, fish were released into the intake bay and collected within two hrs. Curtain walls located between the trash rack and the screen isolated the WIP screen inlet bay from the other travelling screens. Collections off of the screen were diverted to a collection tank where they were collected using a large net and a dip cup. Once all fish were removed, fish were held in recovery tanks. Control groups were exposed to all handling procedures except for introductions and collections off of the screen. Mortality was observed at 8-hr intervals for 48 hrs.

Species impinged, removed, and recovered from the Beaudrey WIP screen exhibited high survival rates (see the following table). Channel catfish and bluegill consistently demonstrated survival higher than 90% while fathead minnow and the native fish group comprised mostly of emerald shiner exhibited survivals between 79 and 85%. There was no significant difference between control and treatment mortality for any species tested, demonstrating that the screen did not impart any mortality.

| Species         | 28 April - 2 May 2008 |       | 11 - 15 August 2008 |       |
|-----------------|-----------------------|-------|---------------------|-------|
|                 | Control               | Test  | Control             | Test  |
| channel catfish | 90.0%                 | 96.1% | 100.0%              | 99.5% |
| bluegill        | 100.0%                | 99.0% | 89.0%               | 91.5% |
| fathead minnow  | 81.0%                 | 79.3% | --                  | --    |
| native fish     | --                    | --    | 82.1%               | 84.6% |

## Case Studies – Laboratory Studies

### **Laboratory Study, Redondo Beach, CA**

A biological evaluation of a modified traveling screen with fine mesh was conducted at a laboratory at Redondo Beach, CA. The testing consisted of two phases. The first phase evaluated the effects of approach velocity, impingement duration, and mesh type on survival. The second phase evaluated the extended survival of fish subjected to impingement, air exposure, and spray wash.

The testing was conducted in one arm of a four-arm test tank. For the phase I testing, panels of the test meshes were inserted in the test chamber, and the flow velocity was regulated through the use of the valves on the inlet/outlet chamber and discharge ports. Plexiglass boxes measuring 40 by 15 cm (15.7 by 6 in.) were constructed to contain the test organisms along with the test meshes. After the stabilization of the velocity in the test chamber, the box was placed in the water, and the stop gates were opened to begin the trial. Observations of fish behavior were made during the test, at its conclusion, and then at 24-hr intervals for 96 hrs.

Fish that avoided impingement for the duration of the test were held separately from those that did impinge. Entrained larvae were collected downstream with a smaller mesh. All test fish were measured for length and a subsample was measured for body width. Control trials were run in which no flow was passed through the test box.

The variables in the Phase 1 testing included six meshes (500, 1,000, 1,800, and 3,300  $\mu\text{m}$  Nytex and 500 and 1,000  $\mu\text{m}$  metal), three approach velocities (0.15, 0.30, and 0.45 m/sec [0.5, 1.0, and 1.5 ft/sec]), and two durations (1 and 4 min).

Phase II testing evaluated the survival of one hardy species (grunion) and one fragile species (Northern anchovy [*Engraulis mordax*]) after impingement, air exposure, and spray wash. These trials were conducted in a 1.2 by 1.2-m (4- by 4-ft) deep flume. Water was supplied by the circulating water pumps at the Redondo Beach Generating Station. Approach velocities were maintained at 0.30 m/sec (1.0 ft/sec) for all tests through the use of a gate valve in the supply line. All tests were conducted on the 1,000  $\mu\text{m}$  mesh screen. The spray wash header had eight nozzles spaced 13 cm (5 in.) apart and positioned 15 cm (6 in.) behind the screen. Spray was

directed at the screen at an angle of 23 degrees and at a pressure of less than 10 psi. Fish were released into the flow at mid-depth, 1 m (3.3 ft) from the screen after they were acclimated. The screen was raised 1 min after release, and the fish were rinsed into the collection tray. The larvae were collected with beakers and held for 96 hr to assess latent mortality. Controls for handling and for the spray wash procedure were conducted as well.

Results of the screen retention evaluation (Table 2-44) indicate that the retention of larvae was dependant on species, body length and depth, mesh, and behavior upon impingement.

**Table 2-44**  
**Larval mean length passed versus mean length retained (LMS 1981)**

| Species  | Test mesh (µm) | Group       |            |            | Mean Length Passed (mm) | N  | Mean Length Retained (mm) | N   | Estimated Range of Retention (mm) |
|----------|----------------|-------------|------------|------------|-------------------------|----|---------------------------|-----|-----------------------------------|
|          |                | Length (mm) | Depth (mm) | Width (mm) |                         |    |                           |     |                                   |
| topsmelt | 1,000 Nytex    | 7.2         | 1.2        | 1.1        | 5.8                     | 40 | 7.2                       | 43  | 7 - 9                             |
|          |                | 8.9         | 1.8        | 1.5        | 7.4                     | 8  | 9.7                       | 104 |                                   |
| topsmelt | 500 Metal      | 8.9         | 1.8        | 1.5        | 7.3                     | 25 | 11.5                      | 3   | 11 - 13                           |
|          |                | 13.3        | 1.7        | 1.4        | 13.4                    | 10 | 14.5                      | 16  |                                   |
| grunion  |                | 10.9        | 1.7        | 1.5        | 9.3                     | 11 | 11.5                      | 22  | 11 - 13                           |
| kelpfish |                | 14.1        | 1.6        | 1.3        | 12.0                    | 2  | 14.0                      | 30  | 16 - 18                           |
|          |                | 18.9        | 2.6        | 2.0        | 17.3                    | 3  | 18.8                      | 26  |                                   |
| kelpfish | 1,800 Nytex    | 18.9        | 2.6        | 2.0        | 15.5                    | 6  | 20.5                      | 27  | 18 - 20                           |
| anchovy  |                | 18.0        | 1.8        | 1.7        | 17.7                    | 30 | 19.4                      | 25  | 18 - 20                           |
| topsmelt | 1,000 Metal    | 18.3        | 2.8        | 2.4        | 16.2                    | 32 | 18.9                      | 47  | 17 - 19                           |
| croaker  |                | 17.8        | 4.7        | 2.6        | 10.7                    | 3  | 19.0                      | 45  | 17 - 19                           |
| kelpfish |                | 18.9        | 2.6        | 2.0        | 16.8                    | 24 | 21.1                      | 8   | 19 - 21                           |
| anchovy  |                | 31.8        | 3.8        | 2.8        | 26.0                    | 2  | 32.7                      | 61  | 28 - 32                           |
|          |                | 34.4        | 4.7        | 3.4        | 22.0                    | 2  | 32.7                      | 89  |                                   |
| croaker  | 3,300 Nytex    | 17.8        | 4.7        | 2.6        | 14.1                    | 40 | 20.0                      | 42  | 18 - 20                           |
| anchovy  |                | 31.8        | 3.8        | 2.8        | 30.8                    | 27 | 32.7                      | 10  | 32 - 34                           |
|          |                | 34.3        | 4.7        | 3.4        | 29.2                    | 49 | 36.4                      | 66  |                                   |

A total of 117 trials were run with topsmelt (*Atherinops affinis*) ranging in length from approximately 7.2 to 18.3 mm (0.28 to 0.72 in.). Species-specific results are given in Table 2-45. In general, a positive correlation between length and survival is noted with large topsmelt (18.3 mm [0.7 in.]) experiencing 100% survival through nearly all testing conditions. Duration was inversely related to survival in most cases. Velocity did not have any overall significant effect on survival for topsmelt, though observations during testing revealed that at the lower

velocities, fish tended to be repeatedly impinged and freed from the screen (increased physical damage from abrasion), whereas at the higher velocity, the larvae would impinge only once. Though mesh size and type did not appear to effect survival significantly, the 500  $\mu\text{m}$  Nytex may increase survival of the more fragile life stages.

Grunion used in this evaluation ranged in size from 9.0 to 18.3 mm (0.35 to 0.72 in.). In general, there was a positive correlation between survival and length similar to topsmelt. Adjusted mean survivals of small, medium, and large grunion were 42, 59, and 80% respectively. Duration had the greatest effect on the small grunion, with higher survivals at the 1 min duration. There were no statistical differences between the mesh types during grunion testing.

Northern anchovy used in this evaluation ranged in length from 18.0 to 37.0 mm (0.71 to 1.46 in.). Survival of the very fragile anchovies used as controls averaged 80% after handling techniques were modified. In general, there was a positive correlation between survival and length. Neither duration nor velocity appeared to significantly affect survival of the anchovies.

Giant kelpfish used in this evaluation fell into one of two length groups, measuring an average of 14.1 mm (0.56 in.) (small) or 18.9 mm (0.74 in.) (large). Average control survival was 71%. As with the other species, survival was significantly related to length with larger fish exhibiting higher survival rates. Giant kelpfish (*Heterostichus rostratus*) were only tested in the 1 min duration as survival at this duration was extremely low. Of the mesh types, the 1,000  $\mu\text{m}$  Nytex yielded the highest survivals and the 500  $\mu\text{m}$  metal the lowest.

White croaker used in this evaluation fell into one of two length groups, measuring an average of 17.8 mm (0.70 in.) (small) or 23.1 (0.91 in.) and 24.8 mm (0.98 in.) (large). Control survival was 100%. Survival of test fish was high also, averaging over 95% for all test conditions. Efforts to conduct impingement tests on croaker measuring less than 17.8 mm (0.70 in.) were unsuccessful due to very low survival of both test and control fish. The authors state that there apparently exists a threshold length above which survival increases dramatically.

Shadow goby used in this evaluation averaged 13 mm (0.51 in.) in length. Control survival was 100%. Survivals were high across all test conditions (97 to 100%), and therefore no statistically significant correlations could be made regarding the test variables.

**Table 2-45**  
**Adjusted mean impingement survival for each test species (LMS 1981)**

| Species  | Mesh Size/Type | Velocity (cm/sec) | Small      |    |            |    | Medium     |    |            |    | Large      |     |            |     |
|----------|----------------|-------------------|------------|----|------------|----|------------|----|------------|----|------------|-----|------------|-----|
|          |                |                   | 1 Min      |    | 4 Min      |    | 1 Min      |    | 4 Min      |    | 1 Min      |     | 4 Min      |     |
|          |                |                   | % Survival | n  | % Survival | n  | % Survival | N  | % Survival | n  | % Survival | n   | % Survival | n   |
| topsmelt | 500 µm Nytex   | 15                | 92         | 35 | 7          | 29 | 98         | 36 | 73         | 37 | c          | –   | c          | –   |
|          |                | 30                | 87         | 43 | 25         | 40 | 76         | 34 | 73         | 37 | d          | –   | d          | –   |
|          |                | 45                | b          | –  | b          | –  | b          | –  | b          | –  | b          | –   | b          | –   |
|          | 1,000 µm Nytex | 15                | 96         | 39 | 42         | 66 | 76         | 37 | 65         | 29 | c          | –   | c          | –   |
|          |                | 30                | 84         | 34 | 31         | 68 | 31         | 32 | 6          | 37 | d          | –   | d          | –   |
|          |                | 45                | 92         | 35 | 62         | 83 | 34         | 27 | 27         | 24 | d          | –   | d          | –   |
|          | 1,800 µm Nytex | 15                | a          | –  | a          | –  | a          | –  | a          | –  | 100        | 33  | 100        | 32  |
|          |                | 30                | a          | –  | a          | –  | a          | –  | a          | –  | 100        | 32  | 100        | 32  |
|          |                | 45                | a          | –  | a          | –  | a          | –  | a          | –  | 100        | 33  | 100        | 33  |
|          | 500 µm Metal   | 15                | a          | –  | a          | –  | a          | –  | a          | –  | c          | –   | c          | –   |
|          |                | 30                | a          | –  | a          | –  | 100        | 16 | a          | –  | 100        | 31  | 97         | 34  |
|          |                | 45                | b          | –  | b          | –  | b          | –  | b          | –  | b          | –   | b          | –   |
|          | 1,000 µm Metal | 15                | a          | –  | a          | –  | a          | –  | a          | –  | c          | –   | c          | –   |
|          |                | 30                | a          | –  | a          | –  | a          | –  | a          | –  | 94         | 17  | 100        | 11  |
|          |                | 45                | a          | –  | a          | –  | a          | –  | a          | –  | 96         | 19  | a          | –   |
| grunion  | 500 µm Nytex   | 15                | 31         | 61 | 12         | 60 | 60         | 30 | 39         | 30 | c          | –   | c          | –   |
|          |                | 30                | 52         | 63 | 18         | 62 | 53         | 60 | 94         | 30 | 66         | 29  | 83         | 30  |
|          |                | 45                | b          | –  | b          | –  | b          | –  | b          | –  | b          | –   | b          | –   |
|          | 1,000 µm Nytex | 15                | 17         | 47 | 21         | 44 | 48         | 28 | 31         | 30 | c          | –   | c          | –   |
|          |                | 30                | 38         | 62 | 20         | 63 | 85         | 31 | f          | –  | 95         | 30  | 60         | 60  |
|          |                | 45                | 57         | 39 | 21         | 32 | f          | –  | f          | –  | f          | –   | f          | –   |
|          | 1,800 µm Nytex | 15                | a          | –  | a          | –  | –          | –  | –          | –  | 100        | 32  | 69         | 109 |
|          |                | 30                | a          | –  | a          | –  | –          | –  | –          | –  | 83         | 140 | 74         | 110 |
|          |                | 45                | a          | –  | a          | –  | –          | –  | –          | –  | 62         | 90  | 44         | 87  |
|          | 500 µm Metal   | 15                | 76         | 49 | 67         | 10 | –          | –  | –          | –  | c          | –   | c          | –   |
|          |                | 30                | 74         | 18 | 81         | 6  | –          | –  | –          | –  | 100        | 30  | 96         | 66  |
|          |                | 45                | b          | –  | b          | –  | –          | –  | –          | –  | b          | –   | b          | –   |
|          |                |                   |            |    |            |    |            |    |            |    |            |     |            |     |



| Species          | Mesh Size/Type | Velocity (cm/sec) | Small      |    |            |   | Medium     |   |            |   | Large      |    |            |    |
|------------------|----------------|-------------------|------------|----|------------|---|------------|---|------------|---|------------|----|------------|----|
|                  |                |                   | 1 Min      |    | 4 Min      |   | 1 Min      |   | 4 Min      |   | 1 Min      |    | 4 Min      |    |
|                  |                |                   | % Survival | n  | % Survival | n | % Survival | N | % Survival | n | % Survival | n  | % Survival | n  |
| grunion          | 1,000 µm Metal | 15                | a          | –  | a          | – | –          | – | –          | – | c          | –  | c          | –  |
|                  |                | 30                | a          | –  | a          | – | –          | – | –          | – | 60         | 42 | 94         | 35 |
|                  |                | 45                | a          | –  | a          | – | –          | – | –          | – | 100        | 36 | 97         | 26 |
| Northern anchovy | 500 µm Nytex   | 15                | 39         | 46 | e          | – | –          | – | –          | – | c          | –  | c          | –  |
|                  |                | 30                | e          | –  | e          | – | –          | – | –          | – | f          | –  | f          | –  |
|                  |                | 45                | b          | –  | b          | – | –          | – | –          | – | b          | –  | b          | –  |
|                  | 1,000 µm Nytex | 15                | 42         | 38 | e          | – | –          | – | –          | – | c          | –  | c          | –  |
|                  |                | 30                | e          | –  | e          | – | –          | – | –          | – | 51         | 38 | 59         | 37 |
|                  |                | 45                | e          | –  | e          | – | –          | – | –          | – | f          | –  | f          | –  |
|                  | 1,800 µm Nytex | 15                | 40         | 25 | a          | – | –          | – | –          | – | c          | –  | c          | –  |
|                  |                | 30                | a          | –  | a          | – | –          | – | –          | – | 64         | 38 | 54         | 40 |
|                  |                | 45                | a          | –  | a          | – | –          | – | –          | – | 18         | 46 | 30         | 37 |
|                  | 3,300 µm Nytex | 15                | a          | –  | a          | – | –          | – | –          | – | c          | –  | c          | –  |
|                  |                | 30                | a          | –  | a          | – | –          | – | –          | – | 60         | 35 | a          | –  |
|                  |                | 45                | b          | –  | b          | – | –          | – | –          | – | 23         | 17 | a          | –  |
|                  | 500 µm Metal   | 15                | a          | –  | a          | – | –          | – | –          | – | c          | –  | c          | –  |
|                  |                | 30                | a          | –  | a          | – | –          | – | –          | – | f          | –  | f          | –  |
|                  |                | 45                | b          | –  | b          | – | –          | – | –          | – | b          | –  | b          | –  |
|                  | 1,000 µm Metal | 15                | a          | –  | a          | – | –          | – | –          | – | c          | –  | c          | –  |
|                  |                | 30                | a          | –  | a          | – | –          | – | –          | – | 47         | 81 | 86         | 34 |
|                  |                | 45                | a          | –  | a          | – | –          | – | –          | – | 51         | 74 | 73         | 32 |
| kelpfish         | 500 µm Nytex   | 15                | 3          | 36 | e          | – | –          | – | –          | – | 42         | 33 | e          | –  |
|                  |                | 30                | 0          | 37 | e          | – | –          | – | –          | – | e          | –  | e          | –  |
|                  |                | 45                | b          | –  | b          | – | –          | – | –          | – | b          | –  | b          | –  |
|                  | 1,000 µm Nytex | 15                | 11         | 41 | e          | – | –          | – | –          | – | 76         | 35 | 0          | 34 |
|                  |                | 30                | 0          | 46 | e          | – | –          | – | –          | – | 9          | 35 | 0          | 33 |
|                  |                | 45                | e          | –  | e          | – | –          | – | –          | – | 24         | 33 | e          | –  |
|                  | 1,800 µm Nytex | 15                | a          | –  | a          | – | –          | – | –          | – | 53         | 28 | e          | –  |
|                  |                | 30                | a          | –  | a          | – | –          | – | –          | – | e          | –  | e          | –  |
|                  |                | 45                | a          | –  | a          | – | –          | – | –          | – | e          | –  | e          | –  |
|                  |                |                   |            |    |            |   |            |   |            |   |            |    |            |    |

| Species       | Mesh Size/Type | Velocity (cm/sec) | Small      |    |            |    | Medium     |   |            |   | Large      |    |            |    |
|---------------|----------------|-------------------|------------|----|------------|----|------------|---|------------|---|------------|----|------------|----|
|               |                |                   | 1 Min      |    | 4 Min      |    | 1 Min      |   | 4 Min      |   | 1 Min      |    | 4 Min      |    |
|               |                |                   | % Survival | n  | % Survival | n  | % Survival | N | % Survival | n | % Survival | n  | % Survival | n  |
| kelpfish      | 500 µm Metal   | 15                | 8          | 36 | e          | -  | -          | - | -          | - | 23         | 28 | e          | -  |
|               |                | 30                | e          | -  | e          | -  | -          | - | -          | - | e          | -  | e          | -  |
|               |                | 45                | b          | -  | b          | -  | -          | - | -          | - | b          | -  | b          | -  |
|               | 1,000 µm Metal | 15                | a          | -  | a          | -  | -          | - | -          | - | a          | -  | a          | -  |
|               |                | 30                | a          | -  | a          | -  | -          | - | -          | - | a          | -  | a          | -  |
|               |                | 45                | a          | -  | a          | -  | -          | - | -          | - | a          | -  | a          | -  |
| white croaker | 500 µm Nytex   | 15                | d          | -  | d          | -  | -          | - | -          | - | d          | -  | d          | -  |
|               |                | 30                | d          | -  | d          | -  | -          | - | -          | - | 97         | 31 | d          | -  |
|               |                | 45                | b          | -  | b          | -  | -          | - | -          | - | b          | -  | b          | -  |
|               | 1,000 µm Nytex | 15                | 100        | 29 | d          | -  | -          | - | -          | - | d          | -  | 100        | 38 |
|               |                | 30                | 95         | 34 | d          | -  | -          | - | -          | - | 100        | 29 | 100        | 31 |
|               |                | 45                | 97         | 32 | d          | -  | -          | - | -          | - | d          | -  | d          | -  |
|               | 1,800 µm Nytex | 15                | 97         | 31 | 97         | 30 | -          | - | -          | - | d          | -  | d          | -  |
|               |                | 30                | 94         | 33 | 97         | 31 | -          | - | -          | - | 97         | 33 | 100        | 29 |
|               |                | 45                | 97         | 30 | 100        | 30 | -          | - | -          | - | d          | -  | d          | -  |
|               | 3,300 µm Nytex | 15                | 94         | 17 | d          | -  | -          | - | -          | - | d          | -  | d          | -  |
|               |                | 30                | 100        | 13 | d          | -  | -          | - | -          | - | 100        | 33 | 100        | 28 |
|               |                | 45                | 100        | 16 | d          | -  | -          | - | -          | - | d          | -  | d          | -  |
|               | 500 µm Metal   | 15                | 91         | 21 | d          | -  | -          | - | -          | - | d          | -  | d          | -  |
|               |                | 30                | 100        | 30 | d          | -  | -          | - | -          | - | d          | -  | d          | -  |
|               |                | 45                | b          | -  | b          | -  | -          | - | -          | - | b          | -  | b          | -  |
|               | 1,000 µm Metal | 15                | 100        | 23 | d          | -  | -          | - | -          | - | d          | -  | d          | -  |
|               |                | 30                | 100        | 29 | d          | -  | -          | - | -          | - | 97         | 33 | d          | -  |
|               |                | 45                | 100        | 23 | d          | -  | -          | - | -          | - | d          | -  | d          | -  |
| shadow goby   | 500 µm Nytex   | 15                | d          | -  | d          | -  | -          | - | -          | - | -          | -  | -          | -  |
|               |                | 30                | d          | -  | 97         | 30 | -          | - | -          | - | -          | -  | -          | -  |
|               |                | 45                | b          | -  | b          | -  | -          | - | -          | - | -          | -  | -          | -  |
|               | 1,000 µm Nytex | 15                | 100        | 26 | 100        | 28 | -          | - | -          | - | -          | -  | -          | -  |
|               |                | 30                | d          | -  | 97         | 30 | -          | - | -          | - | -          | -  | -          | -  |
|               |                | 45                | d          | -  | d          | d  | -          | - | -          | - | -          | -  | -          | -  |

| Species     | Mesh Size/Type      | Velocity (cm/sec) | Small      |   |            |    | Medium     |   |            |   | Large      |   |            |   |
|-------------|---------------------|-------------------|------------|---|------------|----|------------|---|------------|---|------------|---|------------|---|
|             |                     |                   | 1 Min      |   | 4 Min      |    | 1 Min      |   | 4 Min      |   | 1 Min      |   | 4 Min      |   |
|             |                     |                   | % Survival | n | % Survival | n  | % Survival | n | % Survival | n | % Survival | n | % Survival | n |
| shadow goby | 1,800 $\mu$ m Nytex | 15                | d          | – | 100        | 21 | –          | – | –          | – | –          | – | –          | – |
|             |                     | 30                | d          | – | 100        | 10 | –          | – | –          | – | –          | – | –          | – |
|             |                     | 45                | d          | – | d          | –  | –          | – | –          | – | –          | – | –          | – |
|             | 500 $\mu$ m Metal   | 15                | d          | – | d          | –  | –          | – | –          | – | –          | – | –          | – |
|             |                     | 30                | d          | – | d          | –  | –          | – | –          | – | –          | – | –          | – |
|             |                     | 45                | b          | – | d          | –  | –          | – | –          | – | –          | – | –          | – |
|             | 1,000 $\mu$ m Metal | 15                | a          | – | a          | –  | –          | – | –          | – | –          | – | –          | – |
|             |                     | 30                | a          | – | a          | –  | –          | – | –          | – | –          | – | –          | – |
|             |                     | 45                | a          | – | a          | –  | –          | – | –          | – | –          | – | –          | – |

a = <50 % Retention; b = Head loss of screen; c = Not impinged (swimming ability); d = Assumed high survival; e = Assumed low survival; f = Larval shortage; n = Number impinged at duration.

Topsmelt: (Small = 7.2, 8.9, 9.7 mm; Medium = 13.3 mm; Large = 18.3 mm); grunion: (Small = 9.0 to 12.6 mm; Medium = 14.5 to 15.0 mm; Large = 18.2 to 22.3 mm); Northern anchovy: (Small = 18.0 mm; Large = 31.8, 34.3, and 37.0 mm); giant kelpfish: (Small = 14.1 mm; Large = 18.9 mm); white croaker: (Small = 17.8 mm; Large = 23.1 and 24.8 mm); shadow goby: (13mm).

A total of 13 and 29 Phase II tests (impingement, air exposure, and spray wash survival) were conducted for grunion and Northern anchovy respectively (Table 2-46). Results of preliminary tests conducted with two sizes of grunion (29.2 and 15.5 mm mean length [1.14 and 0.61 in.]) yielded survivals of 63% and 49% respectively. Further tests with grunion averaging 20.1 mm (0.79 in.) yielded recovery rates of 88%, 92%, and 100% for test fish, spray and handling controls, and handling controls respectively. Survival of grunion when impingement, air exposure, and spray wash effects are combined was 37.5% to 63.6%. These results compared favorably to Phase I survivals of similarly sized larvae tested for 1 min at 0.30 m/sec (1.0 ft/sec) indicating a decrease from the Phase I survivals of 60% to 100% to 37.5 % to 63.6% due to the additional stress of spray wash and air exposure.

Phase II anchovy tests were conducted with larvae measuring 24.6 mm (0.97 in.) and 32.2 mm (1.27 in.) (means). Initial survival was high (>90%), but few Northern anchovy survived to 24 hrs, and none survived to 96 hrs. When compared to survivals of similarly sized fish impinged for 1 min at 30 cm/sec (1.0 ft/sec) during Phase I, survival decreases from 47 to 64% (Phase I) to 0% (Phase II). The authors indicate that Northern anchovy cannot tolerate the additional stress imparted by the spray wash and air exposure of the collection system.

**Table 2-46**  
**Phase II impingement survival results (LMS 1981)**

| Species          | Mean Length (mm) | Impingement, Air Exposure, and Handling |               |                   | Wash and Handling |               |             | Handling     |               |             |
|------------------|------------------|-----------------------------------------|---------------|-------------------|-------------------|---------------|-------------|--------------|---------------|-------------|
|                  |                  | No. Released                            | No. Recovered | % Surviving       | No. Released      | No. Recovered | % Surviving | No. Released | No. Recovered | % Surviving |
| grunion          | 29.2             | 33                                      | 20            | 63.4 <sup>a</sup> | –                 | –             | –           | –            | –             | –           |
|                  | 15.5             | 29                                      | 27            | 49.2 <sup>a</sup> | –                 | –             | –           | –            | –             | –           |
|                  | 20.1             | 33                                      | 29            | 47.0              | 26                | 24            | 96.7        | 29           | 29            | 96.7        |
| Northern anchovy | 24.6             | 38                                      | 10            | 0.0               | 37                | 28            | 0.0         | 97           | 87            | 0.0         |
|                  | 32.2             | 31                                      | 3             | 0.0               | 29                | 29            | 0.0         | 27           | 27            | 11.1        |

<sup>a</sup> Preliminary tests

### **Laboratory Study, ESEERCO/Alden Research Laboratory**

Survival of a variety of species and life stages following impingement on a fine-mesh screen was investigated in studies sponsored by the Empire State Electric Energy Research Corporation (ESEERCO 1981a; Taft et al. 1981b) and Northern States Power (SWEC 1980; Taft et al. 1981b). The studies were conducted at Alden Research Laboratory (Alden). Striped bass (*Morone saxatilis*), winter flounder (*Pseudopleuronectes americanus*), alewife (*Alosa pseudoharengus*), yellow perch (*Perca flavescens*), walleye (*Sander vitreus*), channel catfish (*Ictalurus punctatus*) and bluegill (*Lepomis macrochirus*) were impinged on a 0.5 mm (0.02 in.) synthetic mesh at velocities ranging from 0.15 to 0.91 m/sec (0.5 to 3.0 ft/sec) and for durations of 2, 4, 8, or 16 min. Initial, latent (96-hr) and total mortality were then determined. Total mortality values are presented in the following summary of results by species.

Striped bass prolarvae (5.4–6.4 mm [0.21–0.25 in.]) showed relatively high mortality under all test conditions. However, control mortality was also high (mean = 56.5%). Striped bass postlarvae (6.5–17.1 mm [0.26–0.67 in.]) mortality averaged less than 10% at velocities up to 2.0 ft/s and impingement durations up to 4 min (control = 8.1%).

Winter flounder prolarvae (4.1 mm [0.16 in.]) experienced mean mortality rates of 7.3, 10.7, 16.5 and 35.6% over all durations at velocities of 0.15, 0.30, 0.46, and 0.61 m/sec (0.5, 1.0, 1.5 and 2.0 ft/sec), respectively (control = 4.1%). Early postlarvae (4.4 mm) experienced very high mortality under all test conditions (control = 42.5%). Later postlarvae (6.1 mm) survived somewhat better, with mortality rates ranging from 16.4 to 36% in six of the nine velocity/duration combinations.

Alewife prolarvae (5.2 to 5.5 mm [0.20 to 0.22 in.]) showed a clear trend of increasing mortality with increasing velocity and impingement duration. At a duration of 8 min, mean mortality was 4.1, 18.9, 44.1 and 69.7% at velocities of 0.15, 0.30, 0.46, and 0.61 m/sec (0.5, 1.0, 1.5 and 2.0 ft/sec), respectively (control = 0%). Postlarvae (6.6 to 14.7 mm [0.3 to 0.6 in.]) showed high mortality (>76%) under all test conditions (control = 43.3%).

Yellow perch prolarvae (5.8 to 6.0 mm [0.23 to 0.24 in.]) showed the same trend as alewife prolarvae with a mean mortality of 6.8, 5.2, 32.3 and 31.5% at velocities of 0.15, 0.30, 0.46, and 0.61 m/sec (0.5, 1.0, 1.5 and 2.0 ft/sec), respectively at a duration of 8 min (control = 4.1%). Postlarvae (6.3 to 6.5 mm [0.25 to 0.26 in.]) also suffered high mortalities (>88%) under all test conditions (control = 85.2%). Later postlarvae (7.3 to 14.3 mm [0.29 to 0.56 in.]) showed improved survival with a mean mortality of 40% at the 0.15 m/sec (0.5 ft/sec) by 8 min impingement duration combination (control = 32.8%).

Walleye larvae (8.4 to 12.0 mm [0.33 to 0.47 in.]) also showed the same trend as alewife prolarvae. At the 0.15 m/sec (0.5 ft/sec) velocity, mortality ranged from 31.4 to 39.5 as the duration increased to 16 min (control = 26.8%).

Channel catfish larvae (11.2 to 25.7 mm [0.44 to 1.01 in.]) showed low mortality under most test conditions. At the 8 min impingement duration, mortality ranged from 3.0 to 5.4 as the velocity increased from 0.15 to 0.61 m/sec (0.5 to 2.0 ft/sec) at an impingement duration of 8 min (control = 3.9%).

Bluegill larvae (15.3 to 21.0 mm [0.6 to 0.82 in.]) experienced low mortality under many test conditions. At 0.3 m/sec (1.0 ft/sec), mortality ranged from 1.5 to 4.0% as impingement duration increased up to 16 min (control = 2.7%).

### **Laboratory Study, Tennessee Valley Authority**

Laboratory studies were performed by the Tennessee Valley Authority to determine the effect of variables such as water velocity, intake screen opening, impingement duration, and larval fish species and size in minimizing mortality of larval fish on a fine-mesh screen intake system (Tomljanovich et al. 1977).

The laboratory tests were conducted in a chamber mounted inside an 18 by 2.4 by 1.2 m (59 by 7.9 by 3.9 ft) test flume. The chamber was constructed of Plexiglas and measured 45.7 by 45.7 by 50 cm (18 by 18 by 19.7 in.). Both ends of the chamber could be completely sealed with Plexiglas stop gates. The downstream end of the chamber was fitted with a cone shaped collection net with 0.5-mm (0.02-in.) mesh. At the end of the net was a removable cup with 0.38 mm (0.015 in.) openings. The eleven species of fish used in the laboratory tests were: jewelfish cichlid (*Hemichromis* spp.), threadfin shad (*Dorosoma petenense*), golden shiner (*Notemigonus crysoleucas*), fathead minnow (*Pimephales promelas*), white sucker (*Catostomus commersonii*), channel catfish (*Ictalurus punctatus*), striped bass (*Morone saxatilis*), bluegill (*Lepomis macrochirus*), smallmouth bass (*Micropterus dolomieu*), largemouth bass (*Micropterus salmoides*), and walleye (*Sander vitreus*). Five square-mesh screens with openings of 0.5, 1.0, 1.3, 1.8, and 2.5 mm (0.02, 0.04, 0.05, 0.07, and 0.1 in.) were tested. Three velocities were tested: 0.15, 0.31, and 0.46 m/sec (0.5, 1.0, and 1.5 ft/sec). Test durations of 0.5, 1, 2, 4, 8, and 16 min were used to determine the survival of impinged larvae.

Fish were allowed to acclimate to the flume for approximately one hr before testing began. Test fish of each species were subjected to at least six impingement durations on at least one screen. The tests were performed with screens of decreasing size until the number of fish retained was approximately equal to the number of fish entrained. Entrained fish were recovered from the collection net. Dead fish were removed from the sample and the remaining fish were held separately for delayed mortality evaluations. Post impingement survival was not corrected for control mortality.

Approximately 40,000 individual fish representing 11 species were used in the 719 laboratory tests. Test duration was found to show the strongest relationship to both immediate and long-term survival of the impinged test fish. In all instances, results revealed that as duration increased, survival decreased (Table 2-47). Other independent variables showed greater variation with respect to survival.

**Table 2-47**  
**48-hr mean percent survival of fish impinged on fine-mesh screens and control groups at the TVA Laboratory (Tomljanovich et al. 1977)**

| Species                          | Hrs Fish Held After Test | Test Duration (Min) |      |      |      |      |      | Mean %Survival of Controls |
|----------------------------------|--------------------------|---------------------|------|------|------|------|------|----------------------------|
|                                  |                          | 0.5                 | 1    | 2    | 4    | 8    | 16   |                            |
| jewelfish cichlid                | Initial                  | 65                  | 81   | 91   | 85   | 90   | 43   | NA                         |
|                                  | 48                       | 53                  | 59   | 83   | 76   | 69   | 30   | 100                        |
| threadfin shad                   | Initial                  | 100                 | 100  | 100* | 98   | 75   | 55   | NA                         |
|                                  | 48                       | 95                  | 93   | 74   | 69   | 43   | 20   | 98                         |
| golden shiner/<br>fathead minnow | Initial                  | 99                  | 95   | 91   | 89   | 90   | 89   | NA                         |
|                                  | 48                       | 94                  | 90   | 90   | 84   | 86   | 79   | 99                         |
| white sucker                     | Initial                  | 99                  | 96   | 99   | 90   | 95   | 74   | NA                         |
|                                  | 48                       | 97                  | 92   | 98   | 80   | 77   | 36   | 100                        |
| channel catfish                  | Initial                  | 100*                | 99   | 100  | 100* | 100* | 97   | NA                         |
|                                  | 48                       | 100*                | 98   | 100  | 99   | 99   | 88   | 99.5                       |
| striped bass                     | Initial                  | 79                  | 85   | 80   | 72   | 51   | 7    | NA                         |
|                                  | 48                       | 22                  | 25   | 27   | 18   | 10   | <1   | 44                         |
| bluegill                         | Initial                  | 100                 | 100  | 100* | 99   | 97   | 96   | NA                         |
|                                  | 48                       | 100                 | 100* | 100* | 99   | 97   | 96   | 99                         |
| smallmouth bass                  | Initial                  | 100*                | 99   | 99   | 98   | 100* | 100* | NA                         |
|                                  | 48                       | 98                  | 88   | 98   | 97   | 98   | 96   | 100                        |
| largemouth bass                  | Initial                  | 93                  | 96   | 94   | 93   | 93   | 70   | NA                         |
|                                  | 48                       | 74                  | 81   | 83   | 61   | 71   | 52   | 93                         |
| walleye                          | Initial                  | 90                  | 79   | 75   | 74   | 35   | 9    | NA                         |
|                                  | 48                       | 63                  | 48   | 49   | 38   | 9    | 2    | 71                         |

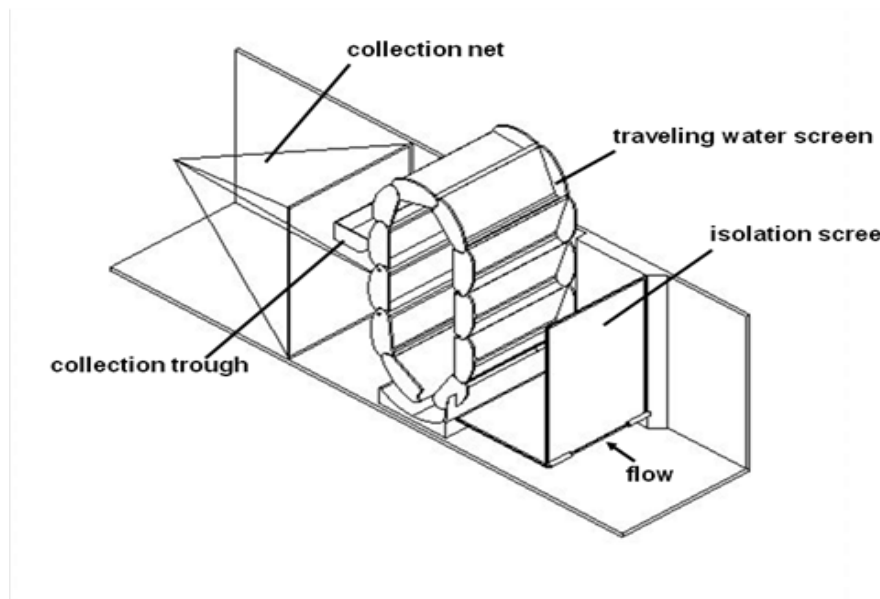
\*Average survival greater than 99.49 but less than 100.00.

### **Laboratory Study – EPRI/Alden**

A laboratory evaluation of traveling water screens was undertaken by the Electric Power Research Institute (EPRI 2006a). The study was conducted at Alden Research Laboratory in a test flume with a small modified traveling water screen (Figure 2-24). The objectives were to characterize fish behavior in the vicinity of a traveling water screen, to determine the effect of swimming time prior to impingement on survival, to determine the effect of approach velocity on



post-impingement survival, to determine the types of injuries sustained during impingement, and to determine the effect of fish length on post-impingement survival.



**Figure 2-24**  
**Test flume including isolation screen, traveling water screen, collection trough, and collection net**

The traveling water screen measured 2.4 by 1.2 m (8 by 4 ft) and had 1.3 cm by 0.64 cm (1/2 by 1/4-in) “smooth-tex” wire mesh. Approach velocities of 0.30, 0.61, and 0.91 m/sec (1.0, 2.0, and 3.0 ft/sec) were evaluated during the investigation of the effects of approach velocity on post-impingement survival. Impingement durations of 2, 4, 6, 8, and 10 min were evaluated during the investigation of the effects of impingement duration on post-impingement survival. The species used in this study included golden shiner (*Notemigonus crysoleucas*), fathead minnow (*Pimephales promelas*), white sucker (*Catostomus commersonii*), bigmouth buffalo (*Ictiobus cyprinellus*), channel catfish (*Ictalurus punctatus*), hybrid striped bass, bluegill (*Lepomis macrochirus*), largemouth bass (*Micropterus salmoides*), yellow perch (*Perca flavescens*), and freshwater drum (*Aplodinotus grunniens*). Mean lengths of each species are presented in Table 2-48. Treatment and control fish were marked on the fins with an inert photonic dye prior to testing.

During velocity trials, the screen was rotated continuously at a speed of 2.4 m/min (8 ft/min), which created a maximum duration of impingement of about 40 seconds. For each trial, 100 fish were introduced to the test enclosure upstream of the screen and allowed to acclimate to an approach velocity of 0.15 m/sec (0.5 ft/sec) for approximately 30 sec. The velocity was then rapidly increased to the target treatment velocity. Behavioral data were recorded during the first 15 min of each trial with submersible cameras. Fish were collected from the collection trough on the downstream side of the screen at 15, 60, and 120 min. Control fish were introduced directly into the collection trough on the downstream side of the screen. Any fish remaining upstream of the screen after 120 min were crowded into the fish collection buckets on the screen face. All collected fish were immediately assessed for condition and classified as “live”, “dead”, or “stunned”. All “live and “stunned” fish were transferred to a holding facility where they were

held for 48 hrs to assess latent survival. At the end of the 48-hr holding period, each fish was euthanized and closely examined for injuries including scale loss, bruising/hemorrhaging, lacerations, severed body, and eye damage.

During duration of impingement trials, the approach velocity was held constant at 0.9 m/sec (3.0 ft/sec). One hundred fish were introduced to the test enclosure upstream of the screen while the screen was held stationary. Fish were allowed to interact with the screen for 2, 4, 6, 8, or 10 min before the screen was rotated. Fish were collected out of the fish collection buckets on the screen face. Control fish were introduced directly to the fish collection bucket on the screen face. All collected fish were immediately assessed for condition and classified as “live”, “dead”, or “stunned”. The condition of all post-test fish was also assessed at 24 and 48 hrs using the same protocol as described above for the velocity trials. The species tested in the duration of impingement trials included channel catfish, golden shiner, and fathead minnow.

A total of 163 (over 19,000 fish) treatment and control replicates were conducted during both parts of this study. However, only 13,000 fish were included in the statistical analysis since some were entrained through the screen, some lacked identifiable marks (only 0.4% of the total collected by impingement on the screen), and others were unaccounted for at the end of the trial.

The results of the velocity trials indicate that there was a threshold between approach velocities of 0.30 and 0.60 m/sec (1.0 and 2.0 ft/sec) at which fish were unable to maintain position upstream of the screen. At 0.30 m/sec (1.0 ft/sec), most fish remained upstream and were collected during the crowding period at the end of the 2-hr trial. At 0.61 m/sec (2.0 ft/sec), a number of fish were able to remain upstream of the screen for the entire 2-hr trial. At 0.91 m/sec (3.0 ft/sec), most fish were collected 15 min after being introduced to the test enclosure. In addition, video revealed that fish were collected by the fish collection buckets on the screen faces in three manners: impinging briefly on screen and then moving into bucket, tail tapping along screen until ending up in bucket, and directly entering bucket and remaining in the quiescent hydraulic zone.

Survival was high for all treatment fish at each approach velocity, ranging between 95.3 and 100%. Survival of control fish was also high, ranging between 97 and 100%. Table 2-48 presents the survival results by species. The only significant effect of velocity on survival was observed with bluegill. The median survival rates observed in this laboratory study were generally greater than the median survival rates observed in previous field studies. However, since median survival rates were comparable, it was concluded that the survival rates of the laboratory study are not substantially higher than what could be expected in the field.

Significantly higher injury rates were observed at higher velocities for some species. The number of fish injured per trial was low for most species, ranging between 0 and 10% for eight of the ten species. The two wild-caught species, white sucker and fathead minnow, sustained the highest injury rates (true for both treatment and control fish). Predation between individuals during post-impingement holding was substantial for bluegill and fathead minnow. While eliminating predation-related injuries did not affect the statistical model for fathead minnow, the statistical model for bluegill did become significant, indicating that velocity exerted a significant effect on survival. The percent of fish injured at each approach velocity is presented in Table 2-49.

Scale loss rates were low for most species but did appear to be significantly correlated to velocity and fish length. Scale loss tended to increase with increasing approach velocity and decrease with increasing fish length. Golden shiner and bigmouth buffalo exhibited the greatest amount of scale loss. Velocity was a significant predictor of scale loss for six of the nine species that had scales (i.e. channel catfish excluded). Fish length was shown to be significant in predicting scale loss for five of the six species that had reliable regressions. In each case, scale loss decreased with increasing fish length.

**Table 2-48**

Mean fork length (mm)  $\pm$  standard error (SE), total number of fish tested (n), survival at 48 hrs after testing, and the 95% confidence intervals (CI) by species and velocity. Confidence intervals were calculated using the normal approximation of a binomial distribution. Freshwater drum, lacking forked tails, were measured to total length.

| Species             | Mean Fork              | 0.3 m·s <sup>-1</sup> |                      |           | 0.6 m·s <sup>-1</sup> |                      |           | 0.9 m·s <sup>-1</sup> |                      |           | Control |                      |           |
|---------------------|------------------------|-----------------------|----------------------|-----------|-----------------------|----------------------|-----------|-----------------------|----------------------|-----------|---------|----------------------|-----------|
|                     | Length (mm) $\pm$ (SE) | n                     | Survival at 48 H (%) | 95% CI    | n                     | Survival at 48 H (%) | 95% CI    | n                     | Survival at 48 H (%) | 95% CI    | n       | Survival at 48 H (%) | 95% CI    |
| bigmouth buffalo    | 72.1 $\pm$ 0.26        | 245                   | 100.0                | 0.0 - 0.2 | 94                    | 100.0                | 0.0 - 0.5 | 142                   | 100.0                | 0.0 - 0.4 | 295     | 99.7                 | 0.0 - 1.1 |
| bluegill            | 47.6 $\pm$ 0.19        | 340                   | 99.1                 | 0.0 - 2.1 | 328                   | 95.4                 | 2.2 - 7.0 | 317                   | 97.8                 | 0.4 - 4.0 | 397     | 98.5                 | 0.2 - 2.8 |
| channel catfish     | 64.2 $\pm$ 0.17        | 206                   | 99.0                 | 0.0 - 2.6 | 148                   | 100.0                | 0.0 - 0.3 | 246                   | 99.6                 | 0.0 - 1.4 | 490     | 100.0                | 0.0 - 0.1 |
| freshwater drum     | 84.7 $\pm$ 0.22        | 243                   | 100.0                | 0.0 - 0.2 | 230                   | 100.0                | 0.0 - 0.2 | 204                   | 99.5                 | 0.0 - 1.7 | 512     | 99.8                 | 0.0 - 0.7 |
| fathead minnow      | 54.5 $\pm$ 0.16        | 393                   | 97.7                 | 0.7 - 3.9 | 343                   | 96.8                 | 1.2 - 5.2 | 296                   | 98.3                 | 0.1 - 3.3 | 493     | 98.8                 | 0.1 - 2.3 |
| golden shiner       | 74.3 $\pm$ 0.31        | 365                   | 98.4                 | 0.2 - 3.0 | 374                   | 98.7                 | 0.0 - 2.6 | 389                   | 98.5                 | 0.2 - 2.8 | 485     | 98.8                 | 0.1 - 2.3 |
| hybrid striped bass | 60.6 $\pm$ 0.14        | 243                   | 99.6                 | 0.0 - 1.4 | 241                   | 100.0                | 0.0 - 0.2 | 356                   | 99.7                 | 0.0 - 1.0 | 498     | 100.0                | 0.0 - 0.1 |
| largemouth bass     | 98.5 $\pm$ 0.30        | 394                   | 99.0                 | 0.0 - 2.1 | 359                   | 97.8                 | 0.5 - 3.9 | 361                   | 97.2                 | 1.0 - 4.6 | 501     | 99.2                 | 0.0 - 1.7 |
| white sucker        | 79.8 $\pm$ 0.35        | 373                   | 95.7                 | 2.1 - 6.5 | 339                   | 95.3                 | 2.3 - 7.1 | 374                   | 95.5                 | 2.3 - 6.7 | 458     | 96.9                 | 1.4 - 4.8 |
| yellow perch        | 49.7 $\pm$ 0.27        | 120                   | 99.2                 | 0.0 - 2.8 | 156                   | 97.4                 | 0.0 - 5.4 | 162                   | 98.8                 | 0.0 - 3.2 | 498     | 99.0                 | 0.0 - 2.0 |

**Table 2-49**  
**Percent injury by species and velocity**

| Species          | Velocity (m·s <sup>-1</sup> ) | Percent Injured | Species         | Velocity (m·s <sup>-1</sup> ) | Percent Injured |
|------------------|-------------------------------|-----------------|-----------------|-------------------------------|-----------------|
| bigmouth buffalo | 0.3                           | 1.60%           | golden shiner   | 0.3                           | 2.70%           |
|                  | 0.6                           | 1.10%           |                 | 0.6                           | 4.80%           |
|                  | 0.9                           | 3.50%           |                 | 0.9                           | 3.10%           |
|                  | Control                       | 1.40%           |                 | Control                       | 4.30%           |
| bluegill         | 0.3                           | 6.80%           | hybrid bass     | 0.3                           | 0.00%           |
|                  | 0.6                           | 9.50%           |                 | 0.6                           | 0.00%           |
|                  | 0.9                           | 5.40%           |                 | 0.9                           | 0.30%           |
|                  | Control                       | 5.50%           |                 | Control                       | 0.00%           |
| channel catfish  | 0.3                           | 4.90%           | largemouth bass | 0.3                           | 1.30%           |
|                  | 0.6                           | 0.00%           |                 | 0.6                           | 10.0%           |
|                  | 0.9                           | 0.40%           |                 | 0.9                           | 6.40%           |
|                  | Control                       | 0.60%           |                 | Control                       | 3.20%           |
| freshwater drum  | 0.3                           | 0.00%           | white sucker    | 0.3                           | 34.0%           |
|                  | 0.6                           | 0.90%           |                 | 0.6                           | 29.80%          |
|                  | 0.9                           | 0.00%           |                 | 0.9                           | 26.70%          |
|                  | Control                       | 1.00%           |                 | Control                       | 23.50%          |
| fathead minnow   | 0.3                           | 23.90%          | yellow perch    | 0.3                           | 1.70%           |
|                  | 0.6                           | 22.70%          |                 | 0.6                           | 1.90%           |
|                  | 0.9                           | 14.50%          |                 | 0.9                           | 0.00%           |
|                  | Control                       | 15.60%          |                 | Control                       | 1.40%           |

The results of the duration of impingement trials indicate that increases in duration resulted in increased mortality, injury, and scale loss. Since no injury or mortality was observed during trials conducted at 2 and 4 min durations, these conditions were eliminated from further replication. In general, survival was high for all species tested, ranging from 100 to 84.9% (not adjusted for control survival) (Table 2-50). Survival rates were also positively correlated to fish length. Scale loss and injury rates varied considerably among species. Channel catfish experienced no injury during these trials. Fathead minnow experienced low levels of scale loss, with at least 80% of fish having scale loss  $\geq 3\%$ . Golden shiner experienced high levels of scale loss, with greater than 50% of the fish having scale loss  $>40\%$ . Additionally, scale loss for both fathead minnow and golden shiner increased with duration of impingement.

**Table 2-50**  
**Survival and injury rates (%) by species and duration of impingement**

| Species         |          | Duration of Impingement (min) |    |      |      |      |         |
|-----------------|----------|-------------------------------|----|------|------|------|---------|
|                 |          | 2                             | 4  | 6    | 8    | 10   | Control |
| channel catfish | Survival | --                            | -- | 100  | 100  | 100  | 98.2    |
|                 | Injury   | --                            | -- | 0    | 0    | 0    | 0       |
| fathead minnow  | Survival | --                            | -- | 93.6 | 93.3 | 97.1 | 99.3    |
|                 | Injury   | --                            | -- | 8.5  | 3.3  | 2.9  | 1.3     |
| golden shiner   | Survival | 0                             | 0  | 96.2 | 84.9 | 87.3 | 90.7    |
|                 | Injury   | 0                             | 0  | 5    | 6.9  | 9.9  | 9.3     |

**Laboratory Study – Hydrolox/Alden**

Hydrolox has developed a polymer-based traveling screen with fish handling capabilities (Alden 2006). This screen operates similar to other modified traveling screens with a few substantial differences. The screen material is made of a lightweight polymer, which results in lighter weight screens compared to standard traveling water screens. The sprockets are made of stainless steel. The top sprocket of the screen is offset from the bottom allowing gravity to assist in debris and organism removal. The Hydrolox screen™ uses a stationary shoe, through which the screen mesh guides rather than a bottom sprocket. The Hydrolox screen tested in the laboratory used a single debris/fish return. However, in a full field application, a second set of spray headers and a dedicated fish return line would be used (Hydrolox unpublished data).

In 2006, a Hydrolox screen was tested at Alden Research Laboratory using five species of freshwater fish: golden shiner (*Notemigonus crysoleucas*), common carp (*Cyprinus carpio*), bluegill (*Lepomis macrochirus*), striped bass (*Morone saxatilis*), and channel catfish (*Ictalurus punctatus*). Tests were conducted in Alden’s Fish Testing Flume using a 1.22 m (4 ft) wide by 3.66 m (12 ft) high, fully operational Hydrolox screen installed perpendicular to the flow (Figure 2-25). Screening material was made of molded plastic with slot openings of 0.64 cm by 0.76 cm (0.25 in. by 0.30 in.). Testing procedures were similar to those used previously to evaluate modified traveling screens (EPRI 2006a). Fish were impinged at 0.31 or 0.61 m/sec (1.0 or 2.0 ft/sec) approach velocity. During testing, the screen was rotated at either 1.5 or 3.1 m/min (5.0 ft/min or 10.0 ft/min).



**Figure 2-25**  
**Hydrolox Screen™ installed in fish testing flume**

For each species, 12 test replicates (2 velocities  $\times$  2 screen speeds  $\times$  3 replicates of each condition) were collected. A randomized treatment design was used. On each day of testing, three, 2-hr treatments and one control replicate were conducted. Control replicates were used to separate mortality associated with handling (removal from holding facility, marking, counting into test groups, and introduction to and removal from the test flume) and natural mortality from mortality imparted by fish interactions with the screening system.

At the beginning of each replicate, the screen rotation speed and approach velocity were set. The isolation screen that confined fish to the traveling screen area was lowered into place. When conducting a treatment replicate, 100 fish of each species were introduced just upstream of the screen in the test enclosure. Impinged fish were washed from the screen into the fish collection trough. At set intervals of 15, 60, and 120 min after introduction to the flume, the fish were sluiced into a collection bucket located at the discharge of the return trough. When conducting a control replicate, 100 marked fish of each species were released into the fish return trough. Once the fish were oriented to the flow, they were sluiced into the collection bucket.

Following the 120 min collection, a mechanical crowder was raised to move fish that were still swimming upstream of the screen into the screen buckets. Velocity in the flume was raised to 0.61 m/sec (2 ft/sec) to facilitate the removal of larger fish. Fish that were entrained through the screen or bypassed the fish return during transfer were collected in a downstream collection net once per day at the end of testing, enumerated, and fork lengths (FL) measured to the nearest millimeter.

At the end of each collection event, any fish recovered from the fish return trough (treatment or control replicate) were transferred back to the holding facility, placed in individually marked net pens, and held for LIM assessment. LIM was monitored at 24- and 48-hrs following impingement. At the end of 48-hrs, all fish were killed and examined for external injuries and percent scale loss. External injuries were recorded by type: bruising/hemorrhaging, lacerations, severed body, eye damage, etc. Using methods similar to those reported by Neitzel et al. (1985) and Basham et al. (1982), percent scale loss (< 3%, 3–20%, 20–40%, and > 40%) was recorded

along the length of the body. All fish were measured for fork length to the nearest millimeter. Any fish unable to maintain equilibrium at 48-hrs after testing was considered dead.

Mortality rates were generally low. For four of five species (golden shiner [*Notemigonus crysoleucas*], common carp [*Cyprinus carpio*], bluegill [*Lepomis macrochirus*], and channel catfish [*Ictalurus punctatus*]), mortality rates were less than 9.1% and for most treatment conditions were under 5% (Table 2-51). Striped bass (*Morone saxatilis*) mortality was higher; however, control mortality was also higher, indicating that this population was sensitive to handling stress and that much of the observed treatment mortality was likely not from exposure to the Hydrolox screen. Three of the five species had successful logistic regressions (golden shiner, bluegill, and striped bass). Length was a significant predictor of mortality for bluegill ( $P < 0.0001$ ) with larger fish exhibited less mortality. All three species with successful logistic regressions exhibited velocity and duration effects. For golden shiner, there was significantly more mortality at the 0.61 m/sec (2 ft/sec) velocity than the control ( $P = 0.0042$  and  $P = 0.0046$  at 1.5 and 3.1 m/min [5 ft/min and 10 ft/min], respectively). For striped bass there was more mortality associated with the lower rotation speeds ( $P = 0.0032$  and  $0.0433$  at 0.31 and 0.61 m/sec [1 and 2 ft/sec], respectively). Only the 0.31 m/sec (1 ft/sec) velocity and 1.5 m/min (5 ft/min) rotation treatment showed significantly more mortality than the control among bluegill ( $P = 0.0042$ ).

**Table 2-51**  
**Summary of mortality rates by treatment condition**

| Species         | Mean Length (mm) | Percent Mortality |                                        |                                        |                                        |                                        | Total |
|-----------------|------------------|-------------------|----------------------------------------|----------------------------------------|----------------------------------------|----------------------------------------|-------|
|                 |                  | Control           | 0.31 m/sec velocity 1.5 m/min rotation | 0.31 m/sec velocity 3.1 m/min rotation | 0.61 m/sec velocity 1.5 m/min rotation | 0.61 m/sec velocity 3.1 m/min rotation |       |
| golden shiner   | 58.3             | 0.2               | 1.4                                    | 1.4                                    | 4.4                                    | 4.1                                    | 2.3   |
| common carp     | 35.9             | 0.0               | 0.0                                    | 0.0                                    | 0.5                                    | 0.0                                    | 0.1   |
| bluegill        | 59.5             | 1.0               | 9.1                                    | 2.8                                    | 2.3                                    | 2.6                                    | 3.1   |
| striped bass    | 77.5             | 9.0               | 17.2                                   | 5.9                                    | 14.4                                   | 13.0                                   | 11.4  |
| channel catfish | 50.7             | 0.0               | 0.8                                    | 0.0                                    | 0.0                                    | 0.0                                    | 0.1   |

Injury rates were also low and ranged from 0.0% to 21.8% for all species (Table 2-52). The majority of bluegill injuries were minor scrapes (82.1%) that did not appear to impact fish behavior. Two species had successful logistic regressions (bluegill and striped bass). Both these species exhibited fewer injuries as fish increased in length ( $P = 0.0063$  and  $P = 0.0453$  for bluegill and striped bass, respectively). Both species exhibited velocity and duration of impingement effects ( $P = 0.0003$  and  $P = 0.0048$  for bluegill and striped bass, respectively). There were significantly more injuries in all treatments than controls for bluegill ( $P < 0.0001$  for all conditions). For striped bass only the 0.61 m/sec (2.0 ft/sec) velocity; 3.1 m/min (10 ft/min) rotation treatment had significantly more injury than control ( $P = 0.0011$ ).



**Table 2-52**  
**Summary of injury rates by treatment condition**

| Species         | Percent Injury |                                                 |                                                 |                                                 |                                                 | Total |
|-----------------|----------------|-------------------------------------------------|-------------------------------------------------|-------------------------------------------------|-------------------------------------------------|-------|
|                 | Control        | 0.31 m/sec<br>velocity<br>1.5 m/min<br>rotation | 0.31 m/sec<br>velocity<br>3.1 m/min<br>rotation | 0.61 m/sec<br>velocity<br>1.5 m/min<br>rotation | 0.61 m/sec<br>velocity<br>3.1 m/min<br>rotation |       |
| golden shiner   | 0.2            | 1.4                                             | 1.4                                             | 2.7                                             | 4.1                                             | 1.9   |
| common carp     | 0.2            | 4.1                                             | 2.9                                             | 0.5                                             | 1.5                                             | 1.0   |
| bluegill        | 2.3            | 9.1                                             | 16.1                                            | 21.8                                            | 20.7                                            | 13.2  |
| striped bass    | 3.9            | 3.2                                             | 6.3                                             | 6.9                                             | 10.6                                            | 5.8   |
| channel catfish | 0.3            | 1.5                                             | 0.6                                             | 0.4                                             | 0.0                                             | 0.4   |

Scale loss for three species was very low (common carp, bluegill, and striped bass). Golden shiner, which are more susceptible to scale loss, exhibited higher levels of scale loss (Table 2-53). This susceptibility to scale loss is demonstrated by the fact that greater than 46% of the control golden shiner exhibited greater than 3% scale loss (Table 2-53). Three of the four species evaluated for scale loss had successful logistic regression ( $P<0.05$ ; golden shiner, common carp, and bluegill). Channel catfish do not have scales and were not evaluated. Golden shiner and bluegill, but not common carp, exhibited a length effect. In both cases, larger fish exhibited less scale loss ( $P<0.05$ ). All three species with successful logistic regressions showed treatment effects. For golden shiner all treatments had significantly more scale loss than controls ( $P<0.05$ ). For both common carp and bluegill the higher velocity treatments (0.61 m/sec [2 ft/sec]) had exhibited more scale loss than control ( $P<0.05$ ).

**Table 2-53**  
**Summary of scale loss rates by treatment condition**

| Species       | Scale Loss Level | Percent Scale Loss |                                           |                                           |                                           |                                           |
|---------------|------------------|--------------------|-------------------------------------------|-------------------------------------------|-------------------------------------------|-------------------------------------------|
|               |                  | Control            | 0.31 m/sec velocity<br>1.5 m/min rotation | 0.31 m/sec velocity<br>3.1 m/min rotation | 0.61 m/sec velocity<br>1.5 m/min rotation | 0.61 m/sec velocity<br>3.1 m/min rotation |
| golden shiner | <3%              | 53.9               | 30.6                                      | 37.6                                      | 51.0                                      | 27.1                                      |
|               | 3–20%            | 41.2               | 43.1                                      | 44.0                                      | 19.8                                      | 39.3                                      |
|               | 20–40%           | 4.7                | 14.6                                      | 10.6                                      | 20.4                                      | 21.4                                      |
|               | >40%             | 0.2                | 11.8                                      | 7.8                                       | 8.9                                       | 12.2                                      |
| common carp   | <3%              | 92.8               | 94.5                                      | 87.1                                      | 86.6                                      | 82.3                                      |
|               | 3–20%            | 5.3                | 2.7                                       | 10.0                                      | 8.8                                       | 16.2                                      |
|               | 20–40%           | 1.5                | 2.7                                       | 2.9                                       | 3.2                                       | 1.5                                       |
|               | >40%             | 0.5                | 0.0                                       | 0.0                                       | 1.4                                       | 0.0                                       |
| bluegill      | <3%              | 98.7               | 97.1                                      | 96.8                                      | 94.3                                      | 91.9                                      |
|               | 3–20%            | 1.3                | 2.4                                       | 3.2                                       | 4.6                                       | 7.8                                       |
|               | 20–40%           | 0.0                | 0.5                                       | 0.0                                       | 0.4                                       | 0.4                                       |
|               | >40%             | 0.0                | 0.0                                       | 0.0                                       | 0.8                                       | 0.0                                       |
| striped bass  | <3%              | 99.0               | 99.6                                      | 98.3                                      | 97.7                                      | 98.6                                      |
|               | 3–20%            | 1.0                | 0.0                                       | 1.7                                       | 1.9                                       | 1.5                                       |
|               | 20–40%           | 0.0                | 0.5                                       | 0.0                                       | 0.5                                       | 0.0                                       |
|               | >40%             | --                 | --                                        | --                                        | --                                        | --                                        |

**Laboratory Study – EPRI/Alden**

A four year evaluation of travelling water screens was undertaken by the Electric Power Research Institute at Alden Research Laboratory (EPRI 2009b; 2010a). Prior to this study, the biological effectiveness of fine-mesh screens was uncertain because the performance data from the few existing facilities that use fine-mesh screens have been highly variable. This project produced additional data necessary to determine the biological efficacy of fine-mesh screens.

The first phase of testing used a small-scale tabletop flume facility conducted in 2006. The experiments focused on the retention and post-collection survival of larval fish exposed to several combinations of impingement duration, velocity, and mesh size. The 2006 results were used to select variables that had the greatest impact on retention and survival for further testing in 2007-08 in a larger flume more typical of an actual cooling water intake structure intake bay.

The tabletop flume was a closed system consisting of a 94,700 L (25,017.1 gal) reservoir, a 15 hp pump, and three acrylic flumes. Water from the reservoir was pumped into the three flumes and the flow in each flume could be independently regulated. Each flume consisted of fine mesh screens mounted perpendicular to the flow. Water depths were maintained by a discharge weir. Water was then released back into the reservoir to end the cycle.

Survival tests consisted of four replicates with each combination of species, velocity, and screen. Tests were conducted at 0.15, 0.30, and 0.61 m/sec (0.5, 1.0, and 2.0 ft/sec) approach velocities with 0.5-, 1.0-, and 2.0-mm (0.02-, 0.04- and 0.08-in.) mesh. Species tested included smallmouth bass (*Micropterus dolomieu*), emerald shiner (*Notropis atherinoides*), fathead minnow (*Pimephales promelas*), channel catfish (*Ictalurus punctatus*), and blue catfish (*Ictalurus furcatus*). On each day of testing, a group of 20 organisms was removed from the holding facility and their notochord length (NL) and head capsule depth (HCD) were measured to the closest 0.1 mm. The average length and HCD were used to represent the length variable in the data analysis. The flume was then set to a specific flow condition and fish were released. Tests were conducted for 4, 8, or 16 min durations, after which flow was maintained and the collection box was slowly raised. Impinged larvae were gently rinsed off into the bucket portion of the collection box. Flow was then turned off and the entrainment net was pulled and rinsed. Mortality was observed immediately and after 24 and 48 hrs. Handling controls were also conducted per impingement duration test.

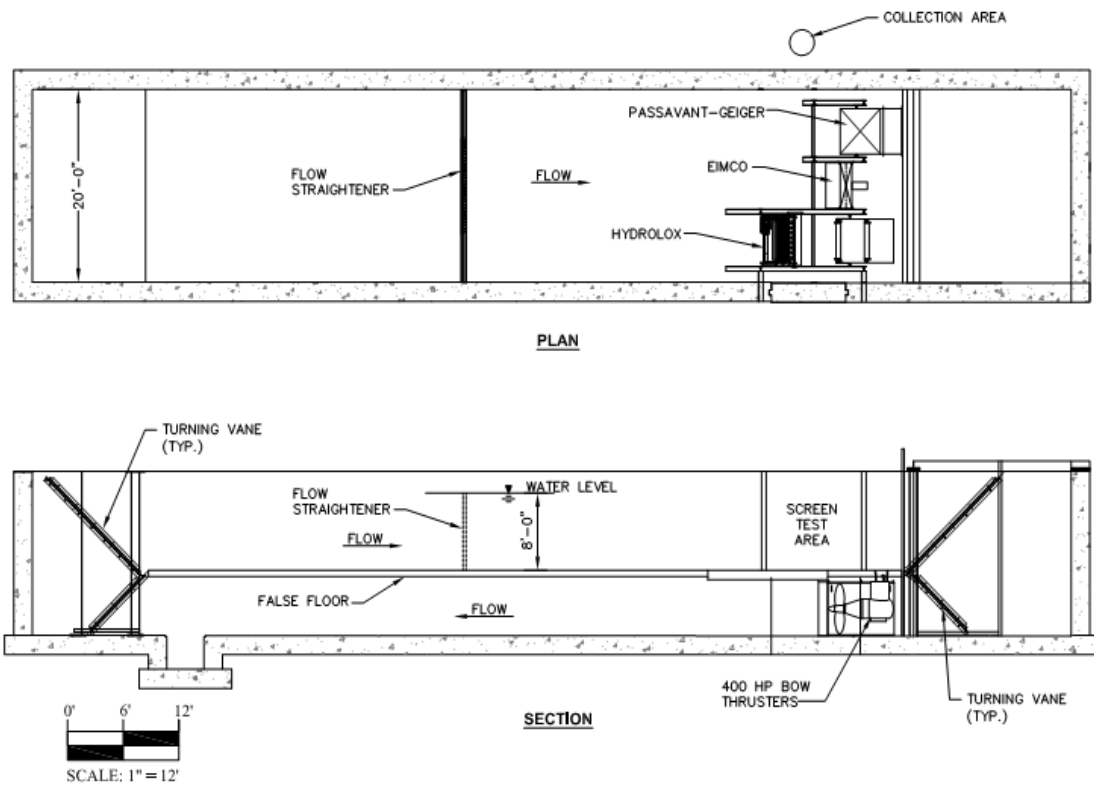
Results for retention tests showed blue catfish and channel catfish exhibited high survival regardless of duration and velocity with the exception of a substantial drop in survival at 0.61 m/sec (2.0 ft/sec) and 16 min duration (Table 2-54). Emerald shiner was only test at 0.61 m/sec (2.0 ft/sec) with high survival at a 4 min retention time and a clear pattern of increasing mortality with increased duration of impingement. Fathead Minnow showed moderate survival with no clear pattern of increased mortality relative to either velocity or retention time. Small mouth bass demonstrated moderate survival overall with no clear pattern of increased mortality relative to retention time at 0.30 m/sec (1.0 ft/sec) and a clear increase in mortality with increasing retention time at 0.61 m/sec (2 ft/sec). In most cases, there was only a fraction of a millimeter difference between head capsule depth between entrained and impinged larvae. In some cases, the head capsule depth was larger than the mesh that was being used (e.g. blue catfish with 2.0 mm screen).

**Table 2-54**  
**Survival rate by species, velocity, and duration in table-top studies with 0.5 mm screen mesh**  
**(EPRI 2010a).**

| Species         | Velocity (ft/s) | Duration (min) | Total Survival | N Retained |
|-----------------|-----------------|----------------|----------------|------------|
| blue catfish    | 1.0             | 8              | 100.0          | 128        |
|                 |                 | 16             | 100.0          | 111        |
|                 | 2.0             | 8              | 100.0          | 90         |
|                 |                 | 16             | 78.2           | 144        |
|                 | Control         |                | 100.0          | 60         |
| channel catfish | 0.5             | 16             | 97.3           | 111        |
|                 | 1.0             | 16             | 99.2           | 121        |
|                 | 2.0             | 4              | 99.1           | 115        |
|                 |                 | 8              | 99.2           | 119        |
|                 |                 | 16             | 18.9           | 122        |
|                 | Control         |                | 100.0          | 119        |
| emerald shiner  | 2.0             | 4              | 96.1           | 104        |
|                 |                 | 8              | 79.6           | 109        |
|                 |                 | 16             | 24.0           | 185        |
|                 | Control         |                | 100.0          | 91         |
| fathead minnow  | 1.0             | 8              | 54.2           | 61         |
|                 |                 | 16             | 75.0           | 67         |
|                 | 2.0             | 8              | 78.3           | 62         |
|                 |                 | 16             | 48.7           | 133        |
|                 | Control         |                | 93.5           | 62         |
| smallmouth bass | 1.0             | 4              | 56.6           | 239        |
|                 |                 | 8              | 59.7           | 235        |
|                 |                 | 16             | 46.2           | 255        |
|                 | 2.0             | 4              | 55.1           | 259        |
|                 |                 | 8              | 25.6           | 299        |
|                 |                 | 16             | 8.2            | 217        |
|                 | Control         |                | 71.3           | 300        |

The second phase testing consisted of testing three through-flow screen designs in a large flume facility from 2007 to 2009. The objective of these tests was to determine the post impingement survival of larval fish of the various screening designs at multiple approach velocities based off of the phase one results. The screening devices used were the EIMCO traditional through-flow screen, the Passavant-Geiger Multi-Disk screen, and the Hydrolox modified through-flow travelling screen.

The prototype-test screen facility remained largely the same in all years of testing (2007-2009). Prototype-scale testing was conducted in a large flume specifically designed for biological and engineering evaluations of fish passage and protection technologies. A plan and section of the flume are presented in Figure 2-26. Located beneath the concrete floor of the test section at the downstream end of the flume were two, 1.7-m (5.6-ft) diameter bow thrusters capable of pumping up to 14.2 m<sup>3</sup>/sec (501.5 cfs) through the test section with the assistance of turning vanes at both ends (i.e., flume water is circulated vertically). The test section was approximately 24.4 by 6.1 m (80 by 20 ft), and water depths were maintained at about 2.4 m (8 ft). At this depth, the bow thrusters are capable of providing a 0.9-m/sec (3.0-ft/sec) velocity over the entire flume width. At the downstream end of the test section, the flume was divided into three screen bays in order to accommodate the three test screens. Each screen bay measured 1.6 m (5.2 ft) wide.



**Figure 2-26**  
**Plan and section of prototype-scale test flume (EPRI 2010a)**



**Figure 2-27**  
**Test flume for prototype-scale screen testing showing the three test screens (EPRI 2009b).**

Screen mesh size, approach velocities, impingement duration, and species were variable amongst years (Table 2-55). The flume was first set to a specific flow condition and fish were released. In 2007-08, the screen was rotated into position to ensure that the injection system would deliver larvae to the vertical center of a predetermined screen panel. In 2009, the screen was rotated continuously during injection and testing. Tests were conducted for specific durations, after which flow was maintained. Fish impinged would be collected by the travelling screen, sprayed off with high and low pressure spray washes, and sluiced to a collection box equipped with a 0.5-mm (0.02-in.) mesh angled barrier net in order to drain the box without losing the sample. After the collection period, the screen and spraywash systems were shut down and troughs were rinsed of any residual debris and organisms. Once the troughs were rinsed, the collection box was drained using the sluice valve downstream of the barrier net and exposed portions of the collection box were gently rinsed with a hose to collect any adhered larvae. A collection pan with screened (0.5 mm [0.02 in.]) overflow windows was used to collect larvae. The collected larvae were transported to the fish holding/sample analysis room in the holding facility for LIM analysis.

**Table 2-55**  
**Screen, mesh size, approach velocity and species tested during corresponding years.**

| Year | Screen (mesh size)       | Approach Velocity (ft/s) | Species Tested                                                       |
|------|--------------------------|--------------------------|----------------------------------------------------------------------|
| 2007 | Hydrolox (1.0 mm)        | 0.5, 1.0                 | channel catfish, common carp, white sucker                           |
|      | OVIVO (0.5 mm)           |                          |                                                                      |
|      | Passavant-Geiger (0.5mm) |                          |                                                                      |
| 2008 | OVIVO (0.5 mm)           | 0.5, 1.0, 2.0            | bigmouth buffalo, channel catfish, common carp                       |
|      | Passavant-Geiger (0.5mm) |                          |                                                                      |
|      |                          |                          |                                                                      |
| 2009 | Acrylic Flume (2.0 mm)   | 0.5, 1.0, 1.5            | bigmouth buffalo, bluegill, common carp, golden shiner, white sucker |
|      | Hydrolox (1.78 mm)       |                          |                                                                      |
|      | OVIVO (2.0 mm)           |                          |                                                                      |
|      | Passavant-Geiger (2.0mm) |                          |                                                                      |

There was considerable variability in survival depending upon species, especially with the earliest life stages. This highly species-specific survival is consistent with what has been observed in field applications of fine-mesh screens (e.g., Taft et al. 1981a; Brueggemeyer et al. 1988; Carolina Power and Light 1985 a, b; Thompson 2000, Kuhl and Mueller 1988).

Survival of larvae over the lengths of fish collected off 0.5- and 1.0-mm (0.02- and 0.-04 in.) screen meshes was extremely poor (generally less than 30% regardless of screen type); control survival for larvae was high by comparison (73%). In general, there was a trend toward decreasing survival as duration of impingement or velocity was increased, but these relationships were not always significant. In 2007-08, in every case where velocity exhibited a significant effect on survival, the 0.5-ft/sec treatments had significantly greater survival than the 0.15-m/sec (1.0-ft/sec) treatments. Duration of impingement was rarely a significant predictor of survival. In all cases where a significant difference was observed, the 4-min duration had greater survival than the 8-min duration. Poor survival likely results from the fact that at this stage in development, larvae were extremely sensitive to impingement. It may be possible that with future improved handling and/or sampling procedures, precision and accuracy of survival may improve; however, with procedures available at this time, survival of larvae collected off these meshes was poor.

Survival of larvae collected off 2.0-mm (0.08-in.) screens was high (roughly 90%). This was likely because larger larvae collected off this mesh size have developed musculature and formed some scales decreasing their sensitivity to impingement and handling stress. The trend of larger larvae (and early juvenile) fish surviving the impingement and collection process has been observed previously in the laboratory (EPRI 2006) and in the field (e.g., McLaren and Tuttle 2000, Beak 2000a, b). Because testing in 2009 focused on larger fish than those tested in 2007-08, the results are difficult to compare. Among the species tested in the large flume, fish 12 mm (1/2 in.) or greater consistently showed high post-collection survival regardless of species, screen type, or approach velocity. This increase in survival appeared to be correlated to scale development and general increase in body musculature. These results are consistent with and expand on results previously reported for larger juvenile fish during EPRI-sponsored impingement survival monitoring of coarse-mesh Ristroph screens in a laboratory flume (EPRI

2006). In those tests, using juvenile and adult fish  $\geq 50$  mm (2.0 in.), post-collection survival exceeded 90% regardless of species or approach velocities (over the range tested 0.3 to 0.9 m/sec [1-3 ft/sec]).

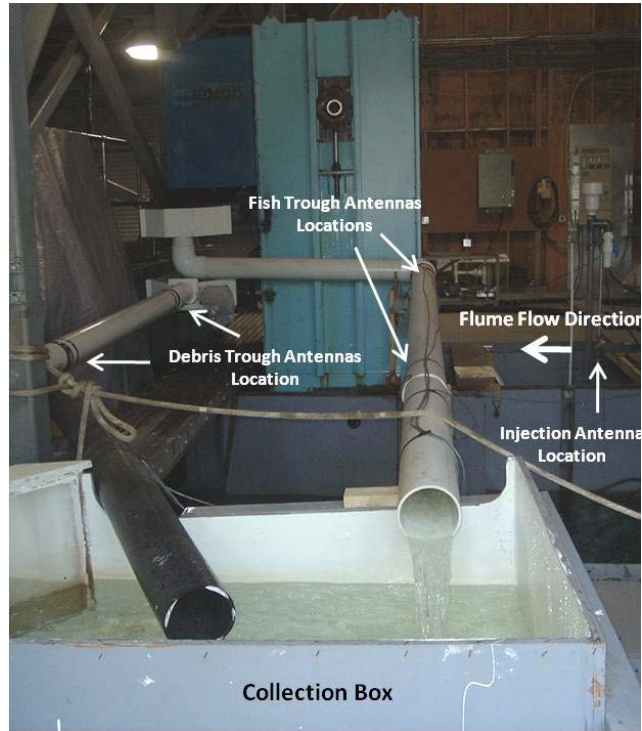
When size exceeded approximately 12.0 mm (1/2 in.), 48-hr post-collection survival for all four species tested exceeded 80%. In several replicates, post-collection survival exceeded 90% and some equaled 100%. All the reported 48-hr survival values are unadjusted for control survival, so actual survival is greater. In some cases, there were no statistical differences between the treatment and control survival indicating no detrimental effect associated with collection and removal from the screens. Survival of 48-hr post-collection for all four species tested ranged from 0 to approximately 60% when fish length was less than approximately 12.0 mm (1/2 in.). Screen approach velocity up to 0.45 m/sec (1.5 ft/sec) had no or minor effect on post-collection survival of the larger larvae tested in 2009.

### ***Laboratory Study – EPRI/Alden***

The performance of fine-mesh screens was tested at Alden Research Laboratory, Inc. Holden, MA (EPRI 2011a). This was a continuation of EPRI-sponsored research on fine-mesh traveling screens and the Beaudrey Water Intake Protection (WIP) screen (EPRI 2011a). In addition to supplying supplemental data, new test parameters were evaluated including quantifying time prior to impingement and determining effects of exposure to high-pressure spraywash.

Two biological investigations of the OVIVO modified traveling screen with 2-mm mesh (OVIVO) and a WIP screen with 2-mm mesh were conducted from June through September 2011. The test flume was configured into two bays using temporary walls to accommodate both screens. The WIP screen fish return system matched testing of the previous year (EPRI 2011a). Fish impinged on the disk screen were suctioned off by a fish-friendly pump and collected in the collection box via a 50 ft pipe. Fish impinged on the OVIVO screen were returned to a collection box through two return lines separating fish exposed to low (fish return line) and high (debris return line) pressure spraywashes (Figure 2-28).

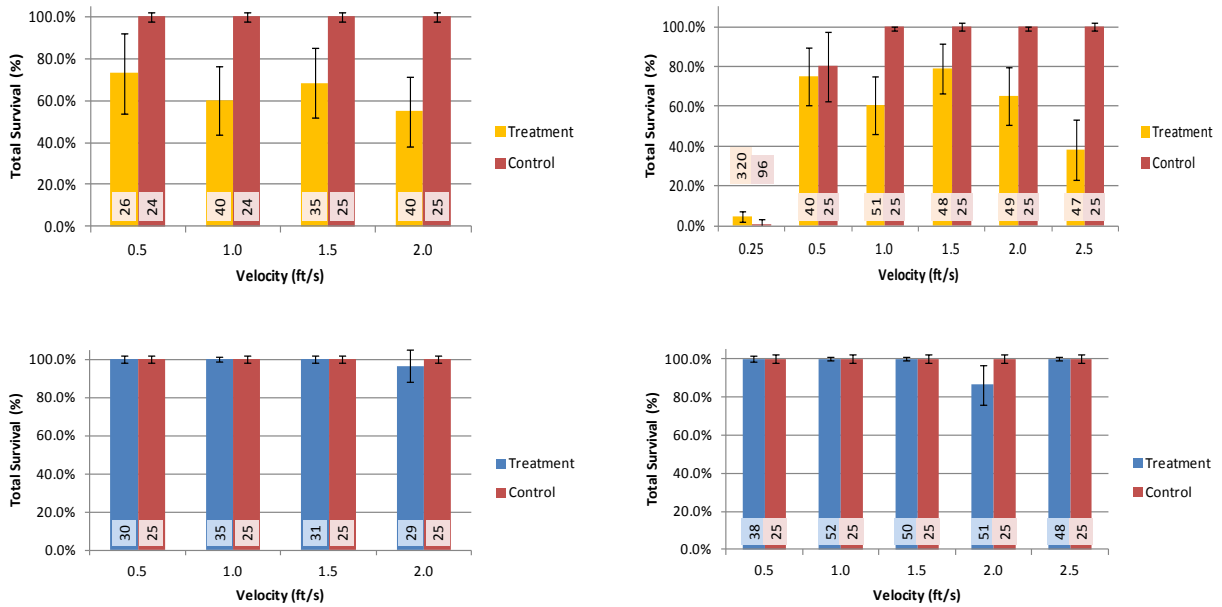




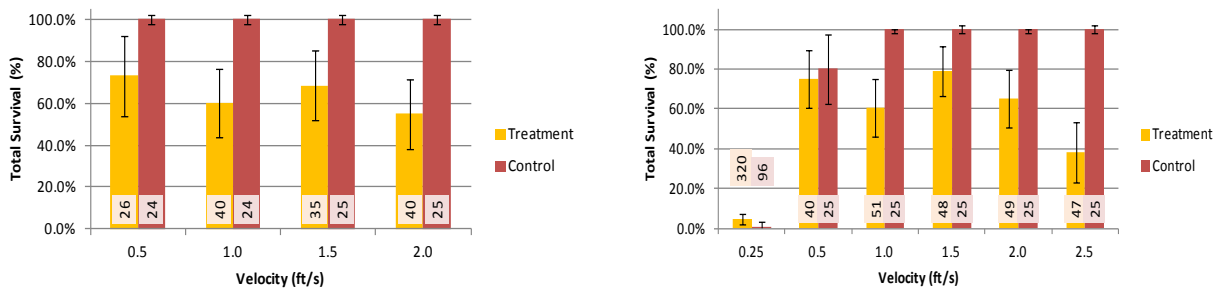
**Figure 2-28**  
**Ovivo screen collection system and PIT tag antenna locations.**

The first of two investigations assessed extended survival of larval golden shiner (*Notemigonus crysoleucas*) and common carp (*Cyprinus carpio*). Tests were conducted on both screens at separate times. Testing commenced with the release of organisms in front of the respected screen face. Once impinged, fish were routed to the screen-specific collection box. Treatments lasted 2 min, after which fish were collected and held for 48-hr mortality observations. Controls replicates were released directly into the collection boxes separate from treatment groups and were held for 2 min prior to collection. Control groups were collected and held identical to treatment fish to separate mortality associated with handling, introduction, collection, and holding from mortality associated with impingement and removal from the screens.

Common carp were tested at velocities of 0.15, 0.30, 0.45, and 0.60 m/sec (0.5, 1.0, 1.5, and 2.0 ft/sec) on the OVIVO screen (Figure 2-29). Survival for all treatment groups was greater than 96.6% and was 100% for control groups. Common carp were tested at velocities of 0.15, 0.30, 0.45, 0.60, and 0.75 m/sec (0.5, 1.0, 1.5, 2.0, and 2.5 ft/sec) on the WIP screen (Figure 2-29). Survival was 100% for all treatment and control groups except for fish tested at 0.60 m/sec (2.0 ft/sec). Golden shiner were tested at velocities of 0.08, 0.15, 0.30, 0.45, and 0.60 m/sec (0.25, 0.5, 1.0, 1.5, and 2.0 ft/sec) on the OVIVO screen (Figure 2-30). Total survival ranged from 55.0 to 73.1% and was 100% for all control groups. Golden shiner were tested at 0.08, 0.15, 0.30, 0.45, 0.60, and 0.75 m/sec (0.25, 0.5, 1.0, 1.5, 2.0, and 2.5 ft/sec) on the WIP screen. Survival ranged from 4.7 to 79.2%.



**Figure 2-29**  
**Common carp total survival on the OVIVO screen (left) and WIP screen (right). The total number of fish held for LM evaluation is presented at the base of each bar. 95% confidence intervals (shown as error bars) were calculated using the normal approximation of the binomial distribution.**



**Figure 2-30**  
**Golden shiner total survival on the OVIVO screen (left) and WIP screen (right). The total number of fish held for LM evaluation is presented at the base of each bar. 95% confidence intervals (shown as error bars) were calculated using the normal approximation of the binomial distribution.**

The second of the two investigations observed avoidance of representative species from being impinged on the OVIVO screen, observing time-to-impingement at approach velocities higher than the 0.5 ft/s trough-screen velocity criterion used by EPA for 316(b) compliance, and the effects of exposure to high (30 PSI) and low (10 PSI) spraywash pressures. Testing was conducted between September 12 and September 15, 2011 (Week 1) and between September 19 and September 22, 2011 (Week 2). Species tested included bluegill (*Lepomis macrochirus*), common carp (*Cyprinus carpio*) and alewife (*Alosa pseudoharengus*). A PIT tag multi-reader system was installed to determine time-to-impingement and spray exposure of tagged fish (Figure 2-28). Antennas were mounted on the injection point to identify initial release time and mounted on both collection troughs to identify time of impingement and identify spraywash exposure. A manual antenna identified the final collection time from the collection tank.

Each test week started on Monday and lasted 72 hrs, ending with a final 5-hr purge (at 2.0 ft/sec or greater). During Week 1, the test velocity was set at 0.15 m/sec (0.5 ft/sec) and run continuously during the test period. During Week 2, the initial velocity was set at 0.15 m/sec (0.5 ft/sec) and increased by 0.15 m/sec (0.5 ft/sec) every 24-hrs. A total of 200 PIT tagged common carp and bluegill were released at the start of testing. During Week 2, a group of 200 untagged alewife was also released at this time. Alewife were not tagged as they were deemed too sensitive to injury and mortality associated with the PIT tagging procedure. Initial collections from the collection box were made 15 min after fish introduction and at 2-hr intervals for the remainder of the test period. If the number of any species remaining in the flume dropped below 150 fish after a collection, 100 fish of that species were added. Fish collected were individually scanned on the manual PIT tag reader, transferred to net pens in the Latent Mortality (LM) holding facility, and held for 48-hr mortality observations. Fish were observed at 24- and 48-hrs after collection. Dead fish were assessed at the time of their observation and all other fish were assessed at the end of the 48-hrs holding period for mortality, injury, and scale loss. Control tests consisted of releasing 100 fish per species into the collection box and held there for 2 hrs prior to collection and subsequently held in the LM facility for 48 hrs. Control fish were assessed identical to treatment fish. At the end of the test week, the velocity in the flume was raised to >2.0 ft/s to collect fish remaining in the flume for the entire one-week duration (purge).

Time-to-impingement was calculated as the difference between the trough antenna time and the injection time. The collection time was used in the absence of a trough read. After data reduction, fish were categorized for data analysis, dependent on quality and presence of PIT tag data (Table 2-56). Fish collected during purges were not used in the analysis.

**Table 2-56**  
**Percent of collected fish by species and week used for analyses (TTI=Time-to-impingement; SISL=Survival, injury and scale loss)**

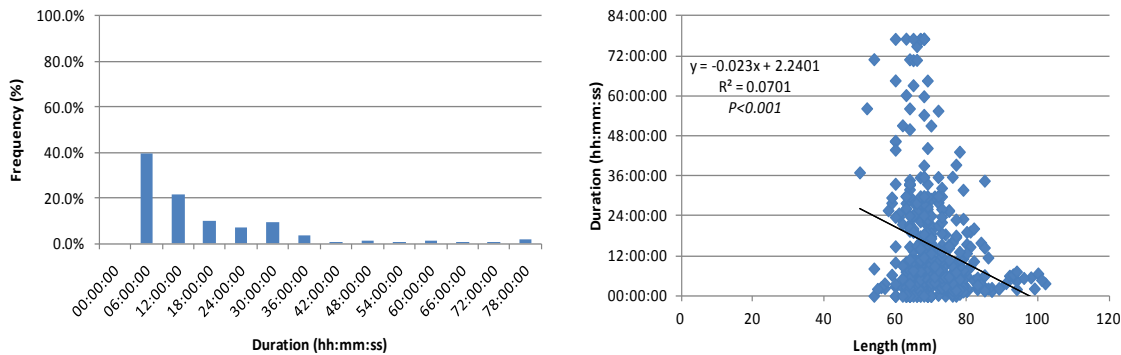
|               | Species     | Analysis | % Used |
|---------------|-------------|----------|--------|
| <b>Week 1</b> | bluegill    | TTI      | 74.7%  |
|               |             | SISL     | 94.7%  |
|               | common carp | TTI      | 59.8%  |
|               |             | SISL     | 74.5%  |
| <b>Week 2</b> | alewife     | SISL     | 75.2%  |
|               | bluegill    | SISL     | 82.0%  |
|               | common carp | SISL     | 67.2%  |

A total of 566 bluegill and 341 common carp were collected during Week 1 tests (Table 2-57). Survival for all species analyzed was 92.9% or higher and injury rates were lower than 7.4%. Scale loss was relatively high for common carp, but this had little noticeable effect on survival.

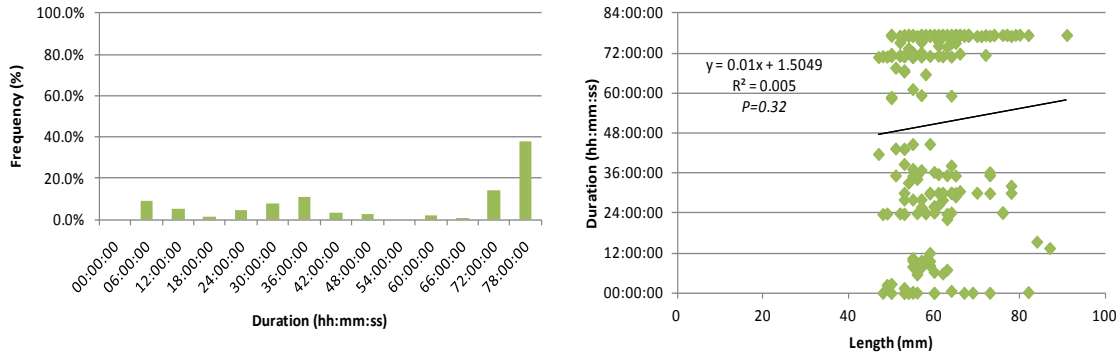
**Table 2-57**  
**Number of fish assessed, conditions and percent survival, injury, and scale loss of <3% by species and week**

|        | Species     | n   | Condition   | % Survival | % Injured | % Scale Loss <3% |
|--------|-------------|-----|-------------|------------|-----------|------------------|
| Week 1 | bluegill    | 408 | 0.15 m/sec  | 99.0%      | 1.2%      | 98.0%            |
|        |             | 102 | Control     | 98.0%      | 2.0%      | 100.0%           |
|        | common carp | 74  | 0.15 m/sec  | 97.3%      | 2.7%      | 82.4%            |
|        |             | 98  | Control     | 99.0%      | 1.0%      | 71.4%            |
| Week 2 | bluegill    | 181 | 0.15 m/sec  | 96.7%      | 2.8%      | 95.6%            |
|        |             | 64  | 0.30 m/sec  | 98.4%      | 0.0%      | 96.9%            |
|        |             | 54  | 0.45 ft/sec | 98.1%      | 7.4%      | 96.3%            |
|        |             | 48  | Control     | 100.0%     | 1.0%      | 99.0%            |
|        | common carp | 38  | 0.15 m/sec  | 97.4%      | 0.0%      | 97.4%            |
|        |             | 55  | 0.30 m/sec  | 100.0%     | 0.0%      | 69.1%            |
|        |             | 52  | 0.45 ft/sec | 100.0%     | 0.0%      | 63.5%            |
|        |             | 100 | Control     | 100.0%     | 1.0%      | 75.0%            |
|        | alewife     | 39  | 0.15 m/sec  | 100.0%     | 2.6%      | 100.0%           |
|        |             | 28  | 0.30 m/sec  | 92.9%      | 0.0%      | 100.0%           |
|        |             | 51  | 0.45 ft/sec | 96.1%      | 3.9%      | 94.1%            |
|        |             | 32  | Control     | 100.0%     | 0.0%      | 96.9%            |

The time to impingement was only presented for the Week 1 analysis. A majority of bluegill were collected within the first 24 hrs (78.7%) (Figure 2-31) while the majority of common carp were collected in the last 24 hrs (54.9%) (Figure 2-32). Time-to-impingement frequency (left) and length relationship (right) for bluegill during Week 1 testing. Time-to-impingement was shown to be dependent of length for bluegill ( $P < 0.001$ ) decreasing with increasing length. However, this only represents 7% of the variability observed ( $R^2 = 0.07$ ) and is likely not biologically significant. Common carp demonstrated that time-to-impingement was independent of length ( $P = 0.317$ ).



**Figure 2-31**  
**Time-to-impingement frequency (left) and length relationship (right) for bluegill during Week 1 testing.**



**Figure 2-32**  
**Time-to-impingement frequency (left) and length relationship (right) for common carp during Week 1 testing.**

Survival, injury and scale loss was not affected by spraywash pressures, during Week 1, having no significant difference in survival between the two spraywash pressures and controls (Table 2-58). The low pressure spraywash, had a significant negative effect on bluegill survival, injury and scale loss. However only slight differences were demonstrated and could be related to low numbers collected from the high pressure spraywash. Common carp demonstrated no negative effects from either spraywash pressures.

**Table 2-58**  
**Percent survival, injury and scale loss by species, number assessed, and spraywash pressure**

|               | Species     | n   | Pressure Wash | % Survival | % Injured | % Scale Loss <3% |
|---------------|-------------|-----|---------------|------------|-----------|------------------|
| <b>Week 1</b> | bluegill    | 330 | Low           | 99.1%      | 2.7%      | 95.2%            |
|               |             | 26  | High          | 100.0%     | 0.0%      | 96.2%            |
|               |             | 102 | Control       | 98.0%      | 2.0%      | 100.0%           |
|               | common carp | 110 | Low           | 99.1%      | 2.7%      | 55.5%            |
|               |             | 4   | High          | 100.0%     | 0.0%      | 75.0%            |
|               |             | 98  | Control       | 99.0%      | 1.0%      | 71.4%            |
| <b>Week 2</b> | bluegill    | 212 | Low           | 97.2%      | 3.8%      | 96.2%            |
|               |             | 19  | High          | 100.0%     | 0.0%      | 100.0%           |
|               |             | 96  | Control       | 100.0%     | 1.0%      | 99.0%            |
|               | common carp | 126 | Low           | 98.4%      | 0.8%      | 75.4%            |
|               |             | 9   | High          | 100.0%     | 0.0%      | 55.6%            |
|               |             | 89  | Control       | 100.0%     | 1.1%      | 73.0%            |

Extended survival of common carp was relatively high (>86%) for both screens while survival was variable, ranging from 4.7 to 79.2%. This was the first time golden shiner has been tested on the WIP screen, expanding the larval survival database. The second evaluation demonstrated

that length does not necessarily play a large role in time-to-impingement. The authors suggest that this could have been due to limited size ranges tested. Survival for common carp and alewife were equivalent to what was observed for other species tested on (>95% regardless of velocity). Spraywash pressures were found not to be a factor in survival.

### **Laboratory Study – EPRI/Alden**

A laboratory evaluation conducted to investigate the Beaudrey Water Intake Protection (WIP) prototype screen within a flume to determine the post-collection survival of larvae and early juvenile fish (EPRI 2009b).

All testing was conducted in a large flume specifically designed for biological and engineering evaluations of fish passage technologies. The test section was approximately 24.4 m long, 6.1 m wide, and water depths were maintained at about 2.8 m (9.2 ft). The WIP screen was provided by Beaudrey at their expense and installed with a 2.0-mm (0.08-in.) square mesh screen. The WIP screen incorporates a large filter disk that is divided into several pie-shaped wedges that rotate on a center axle. Those organisms impinged on the screen were removed and transported by the pump to a collection box located adjacent to the test flume. Four fish species and two size classes (larval and juvenile) were tested during this evaluation (Table 2-59). Velocities tested during the evaluation of larval fish (<30mm (1.2 in.)) were 0.30, 0.45, and 0.61 m/sec (1.0, 1.5, and 2.0 ft/sec) to reflect conditions tested during past fine-mesh screen evaluations with traditional traveling water screens (EPRI 2010a). However, as fish size increased (>30mm (1.2 in.)) and swimming ability increased so was tested velocities (0.9, 1.1 and 1.2 m/sec [3.0, 3.5 and 4.0 ft/sec]). A target of four treatment replicates per velocity and one control replicate were completed per species for a total of 13 tests targeted per block at each species and size (3 velocities by [4 replicates per condition + 1 control]). The control treatment was used to separate mortality associated with handling (removal from holding facility, counting into groups, removal from the collection box, and post-processing of samples) from mortality associated with collection and removal from the screen.

**Table 2-59**  
**Mean, minimum, and maximum total length (mm), and total number of fish tested at low (1.0, 1.5, and 2.0 ft/s) and high (3.0, 3.5, and 4.0 ft/s) approach velocities.**

| Family        | Common Name      | Scientific Name               | Low Velocities |      | High Velocities |      |
|---------------|------------------|-------------------------------|----------------|------|-----------------|------|
|               |                  |                               | n              | Mean | n               | Mean |
| Catostomidae  | bigmouth buffalo | <i>Ictiobus cyprinellus</i>   | 1,983          | 19.3 | --              | --   |
|               | white sucker     | <i>Catostomus commersonii</i> | 1,688          | 19.7 | --              | --   |
| Cyprinidae    | common carp      | <i>Cyprinus carpio</i>        | 1,866          | 25.0 | 1,866           | 25.0 |
| Centrarchidae | bluegill         | <i>Lepomis macrochirus</i>    | --             | --   | 4,273           | 31.0 |

Post-collection survival of all larval and juvenile fish was greater than 60% (the one exception being bigmouth buffalo tested at 0.6 m/sec (2.0 ft/sec), which had post-collection survival of 58%). Post-collection survival was species-specific, with both bluegill and common carp having survival rates between 89% and 100%. The survival for bigmouth buffalo and white sucker

ranged from 66% to 75% depending upon approach velocity (with the exception of the buffalo at 2.0 ft/s, as described above). In general, larger fish and lower approach velocities resulted in greater survival. For almost all species, these fish length and approach velocity effects on survival were significant ( $P < 0.05$ ). The one exception was observed with the smaller common carp tested at 0.3, 0.45, 0.6 m/sec (1.0, 1.5, and 2.0 ft/sec), among which fish length was not a significant predictor of survival ( $P = 0.8813$ ).

Results are subject to several qualifying points as follows:

- Testing was limited to a few species that are readily available as larvae or can be easily cultured in the laboratory. The tested organisms, by their nature, are hardier than pelagic species, such as clupeids and bay anchovy which can dominate actual CWIS entrainment. For example, an ongoing EPRI survey of entrainment at power plants indicates that four of the five<sup>1</sup> top entrained species at coastal/estuarine locations are clupeids (American Shad, blueback herring, Atlantic menhaden, and Gulf menhaden) and, similarly, unidentified clupeids and gizzard shad dominate at plants using freshwater systems for cooling<sup>2</sup>.
- Testing was limited to freshwater species. The results are believed to be indicative of screen performance with estuarine and marine species of comparable hardiness as there is no information that indicates or suggests that either group is more or less sensitive than the other.

### ***Laboratory Study – Aquaria/Alden***

A two phase assessment of the Beaudrey Water Intake Protection (WIP) screen evaluating post-impingement survival of early life stage (larvae and eggs) was conducted for potential application at the Taunton River Desalination Plant (TRDP) (Alden 2012a,b).

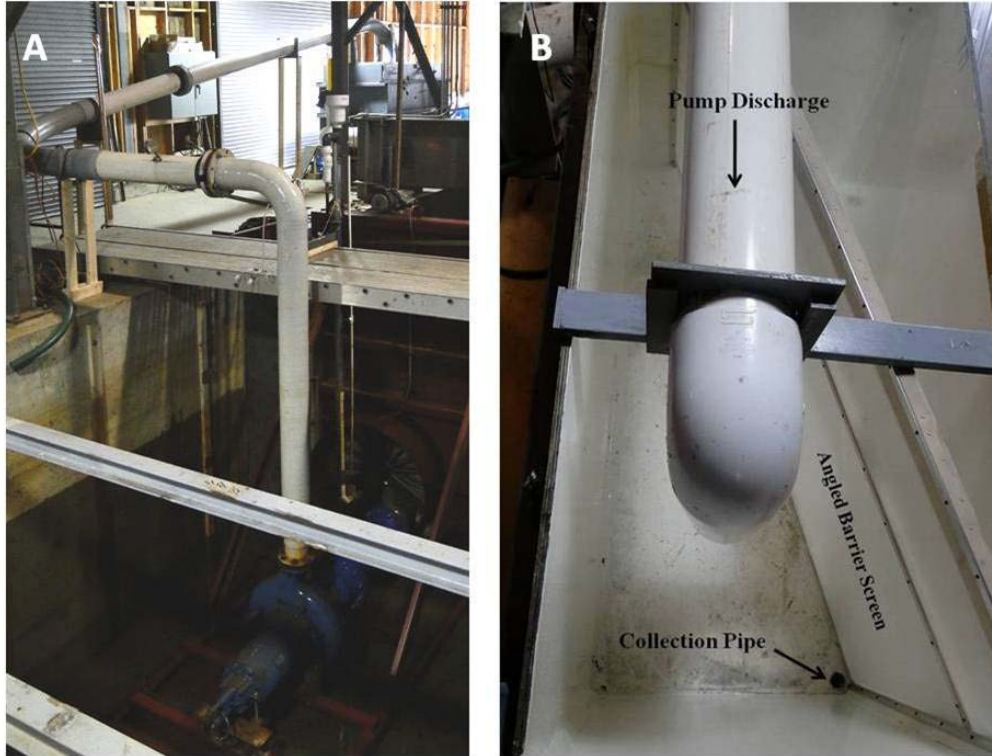
Testing was conducted at The Taft Research and Test Facility at Alden Research Laboratory, Holden, MA in 2011 (Phase I) and 2012 (Phase II). The facility configuration was similar to that of the EPRI-sponsored WIP evaluation (EPRI 2009b) (Figure 2-33). Fish impinged on the screen were removed by a stationary suction scoop and transported to a collection tank via a 15.2-m (50-ft) discharge line. The WIP screen used 2-mm mesh and rotated twice per min.

---

<sup>1</sup> The fifth dominant species is bay anchovy, which is also considered fragile.

<sup>2</sup> Preliminary results from EPRI's ongoing national survey of impingement and entrainment data collected by power plants between 2004-2008 in response to the 2004 EPA §316(b) Phase II Rule which has since been remanded.

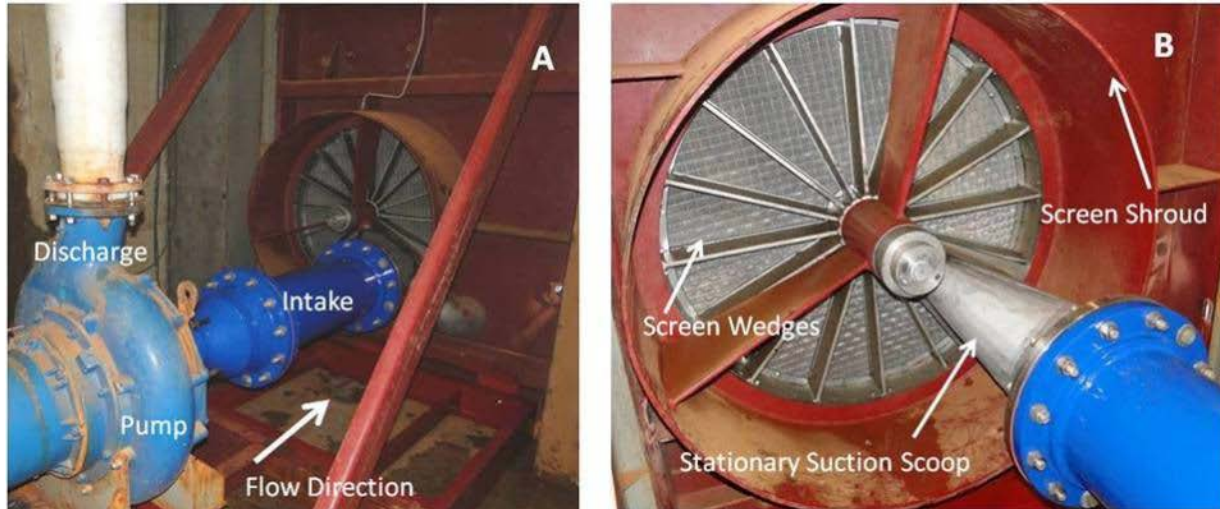




**Figure 2-33**  
**Discharge line from the pump to the collection box (A) and inside view of the collection box (B)**

Phase I testing used fathead minnow (*Pimephales promelas*) (larvae and eggs) as a surrogate species to provide preliminary entrainment estimates and post impingement survival data that can be achieved with the WIP screen. Tests were conducted at velocities of (4.6, 9.1, 15.24 and 24.4 cm/sec [0.15, 0.3, 0.5, and 0.8 ft/sec]). Tests included five replicates of each combination of life stage and velocity. Additional control groups were tested to separate mortality associated with counting into replicate groups, introduction and collection from the test facility, and post test holding from mortality associated with impingement and collection for the WIP screen. During a treatment replicate, 100 live organisms were released just upstream of the center of the screen face via an injection tube. Tests ran for a total of 5 min to increase the potential for organism collection. Impinged organisms were removed by a stationary suction scoop attached to a fish-friendly pump and transferred to a collection box located adjacent to the test flume. Entrainment was estimated by subtracting the number of fish collected from the number of released. This estimate assumes that any fish not collected was entrained through the mesh and provided a conservative estimate of entrainment. Once a replicate was completed, organisms were collected and processed as described below. Control tests were released directly into the collection box on separate releases and collected using the same procedure as treatments.





**Figure 2-34**  
**Prototype Beaudry WIP screen and pump**

Immediately after each collection all dead organisms were enumerated and live organisms were held for latent mortality (LIM) observations. Delayed mortality for larvae was observed after 24 and 48-hrs. Dead larvae were enumerated and then photographed for morphometric measurement. After the 48-hr holding period, all live larvae were euthanized, enumerated, and photographed. Egg survival was determined by hatchability. Eggs were held up to 144 hrs post test, the time in which all hatching occurred. Live larvae found were identified as hatched eggs. Dead larvae found were analyzed two different ways 1) as being hatched and subsequently dying and 2) being dead prior to hatching. All eggs not hatched within 144 hrs were considered dead. Separate handling controls were conducted by counting organisms into replicate groups, immediately placing them in the holding facility, and held alongside the treatment and control fish during the latent mortality observation period. The handling controls were included to separate mortality associated with counting and holding from mortality associated with introduction and retrieval from the collection system.

A total of 2,684 larvae were released during Phase I testing. Potential entrainment ranged from 0.2% (4.6 cm/sec [0.15 ft/sec]) to 14.8% (24.4 cm/sec [0.8 ft/sec]) for larvae. Survival for larvae (Table 2-60) demonstrated a threshold between 4.6, 9.1 cm/sec (0.15 and 0.3 ft/sec) where mortality increased significantly ( $P < 0.05$ ).

**Table 2-60**  
**Fathead minnow larval numbers collected and total survival for each velocity tested and the controls.**

| Velocity | No. Collected | No. Live (48hr) | Survival |
|----------|---------------|-----------------|----------|
| 0.15     | 489           | 267             | 54.6%    |
| 0.3      | 454           | 165             | 36.3%    |
| 0.5      | 424           | 175             | 41.3%    |
| 0.8      | 419           | 161             | 38.4%    |
| Control  | 496           | 254             | 51.2%    |

Control survival was relatively similar to treatment groups while handling control survival was high (98%). This indicates that some of the mortality observed in the treatment groups was associated with exposure to the collection box and subsequent collection. The authors speculate that this mortality was likely a result of turbulent conditions in the collection box or the methods used to remove the organisms. To account for this mortality, treatment survival was adjusted using a Ricker model:

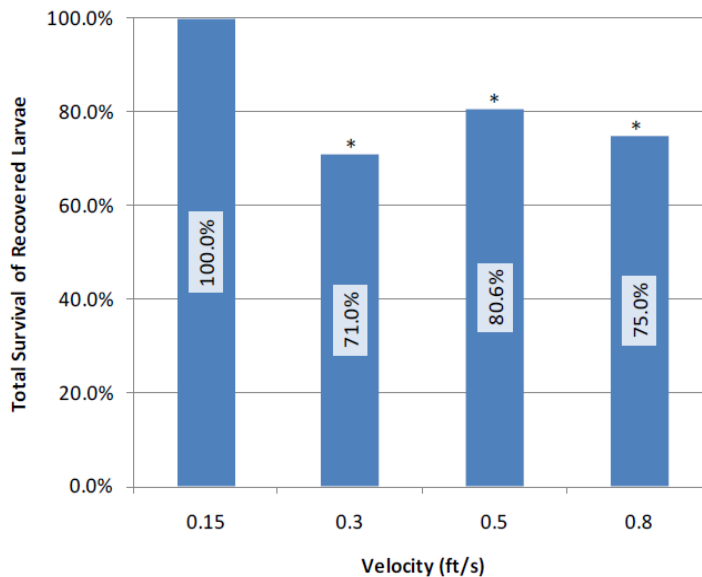
$$\text{Adjusted Total Survival} = \frac{r_t/R_t}{r_c/R_c}$$

where:  $r_t$  = treatment fish live at 48 hrs

$r_c$  = treatment fish collected

$R_t$  = control fish live at 48 hrs

When adjusted, survival rates were 71% or greater for all treatment conditions (Figure 2-35).



**Figure 2-35**

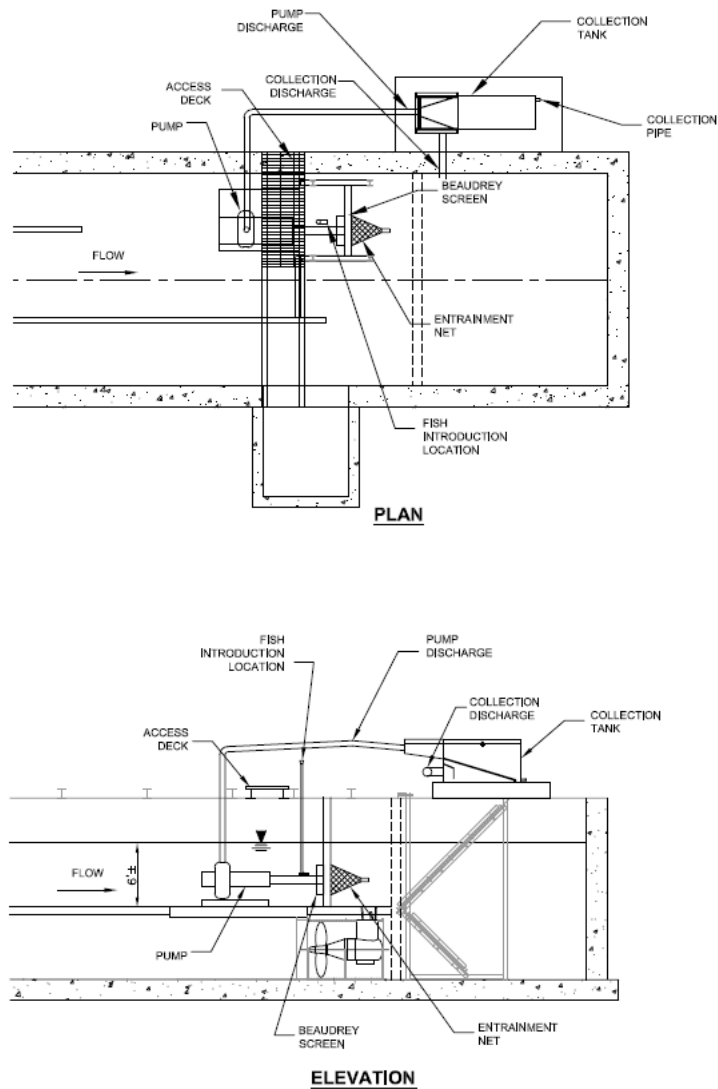
**Adjusted survival for fathead minnow larvae using the Ricker model. Asterisks denote significant difference to controls.**

A total of 2,620 eggs were released during Phase 1 testing. Egg entrainment ranged from 1.6% (0.3 ft/s) to 4.0% (0.15 and 0.8 ft/s). Total survival of eggs exceeded 86% for all treatments (Table 2-61). Inclusion of dead larvae as hatched eggs did not significantly change outcomes ( $P > 0.05$ ).

**Table 2-61**  
**Fathead minnow egg numbers collected, total survival including and excluding dead larvae for each velocity tested and the controls.**

| <b>Velocity</b> | <b>No. Collected</b> | <b>No. Live Including Dead Larvae</b> | <b>No. Live Excluding Dead Larvae</b> | <b>Survival Including Dead Larvae</b> | <b>Survival Excluding Dead Larvae</b> |
|-----------------|----------------------|---------------------------------------|---------------------------------------|---------------------------------------|---------------------------------------|
| 0.15            | 470                  | 462                                   | 442                                   | 98.3%                                 | 94.0%                                 |
| 0.3             | 480                  | 471                                   | 465                                   | 98.1%                                 | 96.9%                                 |
| 0.5             | 484                  | 430                                   | 419                                   | 88.8%                                 | 86.6%                                 |
| 0.8             | 480                  | 468                                   | 460                                   | 97.5%                                 | 95.8%                                 |
| Control         | 483                  | 462                                   | 455                                   | 95.7%                                 | 94.2%                                 |

Phase II testing used essentially the same flume configuration as Phase I with minor adjustments. The collection box was redesigned to reduce turbulence and a net was installed on the downstream side of the screen to better quantify entrainment (Figure 2-36). Survival tests included five replicates of all combinations of species, life stage, and velocity. White perch (*Morone americana*; eggs and larvae) and alewife (*Alosa pseudoharengus*; larvae) were used during testing. Tests were conducted at velocities of 0.8, 0.11, and 0.14 m/sec (0.25, 0.35, and 0.45 ft/sec). The testing procedure for impingement collections, controls, and handling controls mimicked Phase I testing. Entrainment samples collected in the downstream net were enumerated, but not held for LIM observation.



**Figure 2-36**  
**Taft Fisheries Research and Test Facility configured for the Phase II biological evaluation of the Beaudrey WIP screen.**

Approximately 1,600 white perch larvae, 2,350 white perch eggs, and 5,000 alewife larvae were released during Phase II testing. Entrainment for treatment groups ranged from 21.3% (0.8 m/sec [0.25 ft/sec]) to 26.3% (0.14 m/sec [0.45 ft/sec]) for white perch larvae and from 15.7% (0.14 m/sec [0.45 ft/sec]) to 19.4% (0.8 m/sec [0.25 ft/sec]) for alewife larvae. There was no entrainment of white perch eggs as the average egg diameter (0.9 mm) was much larger than the 0.5-mm mesh. Total survival was less than 5% for white perch larvae and less than 1% for alewife larvae among all treatment and control groups (table 2-62). Survival for white perch eggs ranged from 31.8% (0.14 m/sec [0.45 ft/sec]) to 61.2% (0.11 m/sec [0.35 ft/sec]). Similar to Phase I testing, handling controls exhibited higher survival than control survival. Adjusted survival for handling control using a Ricker model resulted in substantially higher rates of survival for treatment and control tests.

**Table 2-62**

**White perch larval numbers collected, total survival and adjusted survival for each velocity tested and the controls.**

| <b>Species</b>     | <b>Velocity</b> | <b>No. Collected</b> | <b>No. Live (48hr)</b> | <b>Unadjusted Survival</b> | <b>Adjusted to Handling Control</b> |
|--------------------|-----------------|----------------------|------------------------|----------------------------|-------------------------------------|
| alewife            | 0.25            | 758                  | 0                      | 0.0%                       | 0.0%                                |
|                    | 0.35            | 738                  | 1                      | 0.2%                       | 0.3%                                |
|                    | 0.45            | 787                  | 787                    | 0.2%                       | 0.3%                                |
|                    | Control         | 906                  | 8                      | 0.9%                       | 1.5%                                |
| white perch larvae | 0.25            | 256                  | 6                      | 3.5%                       | 12.1%                               |
|                    | 0.35            | 187                  | 2                      | 1.8%                       | 6.0%                                |
|                    | 0.45            | 182                  | 1                      | 1.0%                       | 3.3%                                |
|                    | Control         | 205                  | 9                      | 4.4%                       | 15.1%                               |
| white perch eggs   | 0.25            | 468                  | 240                    | 51.3%                      | 84.7%                               |
|                    | 0.35            | 448                  | 274                    | 61.2%                      | 100.0%                              |
|                    | 0.45            | 444                  | 141                    | 31.8%                      | 52.4%                               |
|                    | Control         | 457                  | 253                    | 55.4%                      | 91.4%                               |

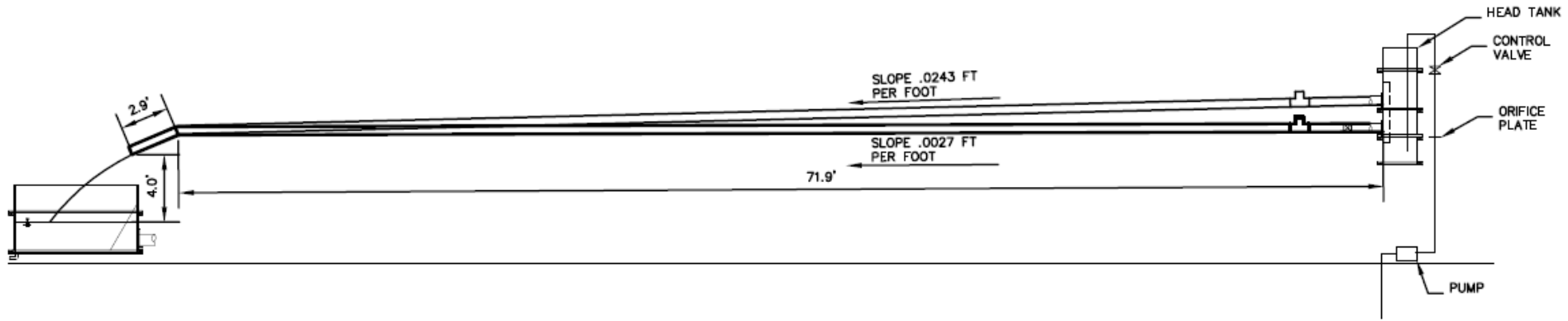
### **Laboratory Study – EPRI/Alden**

A three year evaluation of fish return systems was undertaken by the Electric Power Research Institute at Alden Research Laboratory (EPRI 2010b, 2011c). Prior to this study, the biological effectiveness of fish return systems was uncertain because the performance and survival data was limited. Additionally, site-specific impingement data for traveling screens typically include collecting organisms within the return system, not at the outfall of the return line, therefore any injury or mortality associated with the return system was not evaluated.

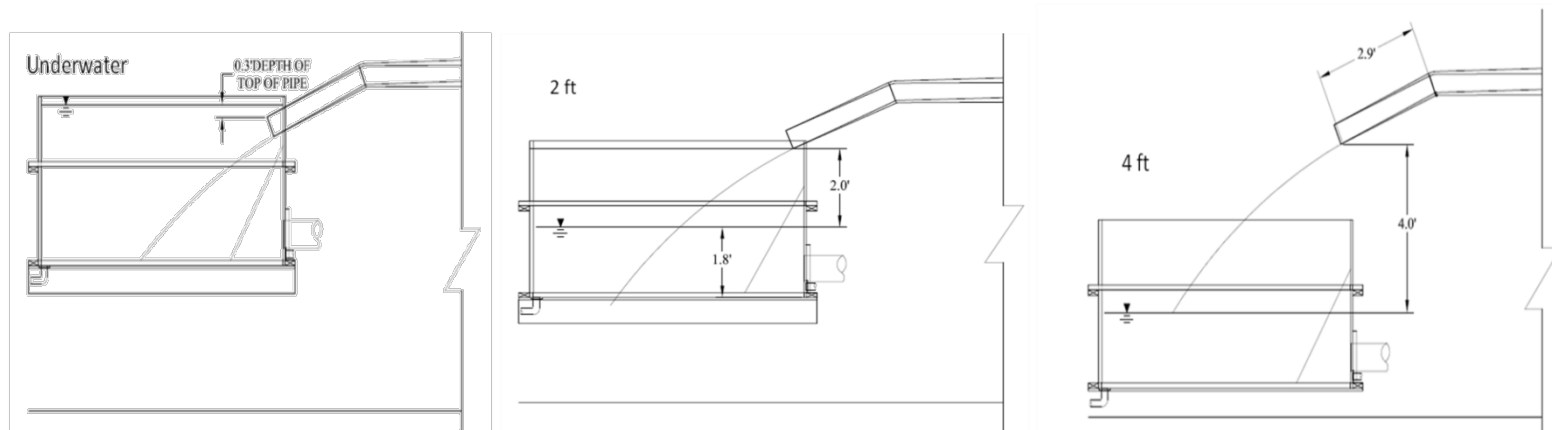
The first phase of testing was designed to evaluate the effects of velocity and discharge height on larval fish survival through a fish return system. A primary consideration in the design of the phase one test apparatus was to keep, to the extent practicable, the system components similar while varying both velocity and release height. A parallel return pipe system was designed which resulted in the larvae traveling the same distance and allowed use of the same collection system (Figure 2-37). Each return pipe was 15.2-cm (6-in.) diameter and approximately 21.6 m (71 ft), but had a different slope to achieve transport velocities of 0.6 m/sec (2 ft/sec) in one and 1.8 m/sec (6 ft/sec) in the other. Each pipe contained an injection point on the upstream end and a 23 degree elbow with a 0.91 m (3 ft) section of clear pipe at the discharge end.

An adjustable collection box was used to obtain three different conditions at the return pipe discharges; underwater, 0.61-m (2-ft), and 1.22-m (4-ft) discharge heights (Figure 2-38). The box was 0.91 m (3 ft) wide by 2.13 m (7 ft) long by 1.22 m (4 ft) deep. A 25.4-cm (10-in.) diameter stand pipe with a valve and a 5.08 cm (2 in.) drain pipe controlled by a gate valve were located on the upstream side of the collection tank behind an angled barrier screen (with 350- $\mu$ m mesh) to maintain water level. This design allowed the box to be drained when making a collection without removing organisms.

Survival testing included three replicates with each combination of species, life stage, velocity, and drop height. Four species were evaluated during phase one testing (Table 2-63). For each species at a given size, 21 replicates were targeted (2 velocities) by (3 discharge heights) by (3 replicates per condition) plus (3 controls [one per height]). To ensure that results for each fish length were comparable all 21 replicates for a given species were completed within one test week. In addition, sets of replicates were repeated as the larvae grew to determine the effect of larval length on survival. The control was used to separate mortality associated with handling (removal from holding facility, counting into groups, collection from fish return, and post-processing of samples) from mortality associated with passage through the return line system. Each replicate was assessed for initial survival and then held for 48 hrs to assess latent effects. Initial survival was calculated by enumerating the number alive at the end of the test and dividing by the total number of live and dead organisms collected. Extended survival was calculated using the total number of live organisms at the end of 48 hrs and dividing it by the total number held for latent mortality observation. Total survival was calculated using the total number alive after the 48 hrs observation and dividing it by the total number collected during that replicate.



**Figure 2-37**  
Section view of fish return system testing loop with collection box at the 4 ft discharge height.



**Figure 2-38**  
Configuration of collection box at each discharge height; underwater, 2 ft, and 4 ft.

**Table 2-63**  
**Species, lengths, and number measured of those fish used in Phase I testing**

| Species          | Total Length |                    |              |              |                 |
|------------------|--------------|--------------------|--------------|--------------|-----------------|
|                  | Mean (mm)    | Standard Deviation | Minimum (mm) | Maximum (mm) | Number Measured |
| bigmouth buffalo | 8.2          | 2.1                | 6.2          | 11.7         | 260             |
| channel catfish  | 14.3         | 3.3                | 10.4         | 17.2         | 200             |
| golden shiner    | 6.4          | 2.2                | 4.2          | 11.3         | 180             |
| common carp      | 9.4          | 2.8                | 5.6          | 12.8         | 500             |

Survival for all species decreased during the transition from yolk-sac to post-yolk-sac larvae with the exact length varying by species. Survival increased rapidly with increasing fish length with a peak when larvae attained a size of approximately 12 mm (0.47 in.). Velocity had no effect on survival within length groups and with the exception of common carp (*Cyprinus carpio*), drop height ( $\leq 1.8$  m or 6 ft) had no effect on survival within length groups.

Channel catfish (*Ictalurus punctatus*) initial survival observed for all conditions was high (> 94%) and results showed no trend between total survival and length, given that total survival was high for all length classes. This trend is supported by the statistical analysis which showed no significant length effect on total survival ( $P=0.0616$ ).

Common carp showed increased mortality when exposed to greater discharge heights independent of the velocity. The total survival among each variable was statistically compared, the results indicate that there is no significant difference between the velocities ( $P=0.1590$ ); however, both the 0.61-m (2-ft) and 1.22-m (4-ft) discharge heights have significantly lower survival than the underwater discharge ( $P=0.0458$  and  $0.0471$ , respectively).

Bigmouth buffalo (*Ictiobus cyprinellus*) total survival showed no statistically significant differences in total survival between the control and treatment replicates ( $P=0.4441$ ). The comparison of survival with respect to larval length, showed a more defined decrease in survival for all conditions at the 7 mm length.

Golden shiner (*Notemigonus crysoleucas*) data were limited due to poor survival in the holding facility and during early lifestage testing. Total survival numbers (including controls) were considerably lower than other species at the yolk-sac lifestage. The statistical analysis of total survival indicated that there was a significant difference between treatments and controls ( $P=0.0123$ ), specifically at the 4 ft discharge height ( $P=0.0285$ ). A significantly higher survival was observed for the 1.8 m/sec (6 ft/sec) velocity when compared to 0.6 m/sec (2 ft/sec) ( $P=0.0425$ ) and the 4 ft discharge when compared to the underwater ( $P=0.0100$ ). The author stated that these findings are most likely the result of the limited numbers tested and the poor survival observed with this species over the course of the testing.

The phase two testing included the modification of the phase one facility to assess additional length, drops, bends, and turns within a return line. A phase one return line was retained for the testing and an additional line with more complexity (length, drops, turns, etc.) was constructed that allowed the use of the same phase one collection box described above (Figure 2-39). Both



lines were constructed to maintain a velocity of 1.8 m/sec (6 ft/sec) and an underwater discharge. The phase two return line was constructed to allow testing from two release locations. The “head of long line” release point was selected to expose the organisms to the full length of the phase two return line. The “upstream “S” line” release point was selected to allow assessment of the affect of the tight radius turns section without the effect of a longer distance of transport. Additionally, organisms were released through the phase one line (“head of short line”) and directly into the collection tank for the control fish. As in the phase ones testing both return pipes were each 15.2-cm (6-in.) diameter; however, each had a different transport distance (approximately 21.6 m [71 ft] for the phase one and approximately 131 m [430 ft] for the phase two line). In addition to the added length the phase two line included a 0.61m (2 ft) drop, a large radius turn, and several tight turns which included four 180 degree and two 45 degree turns.

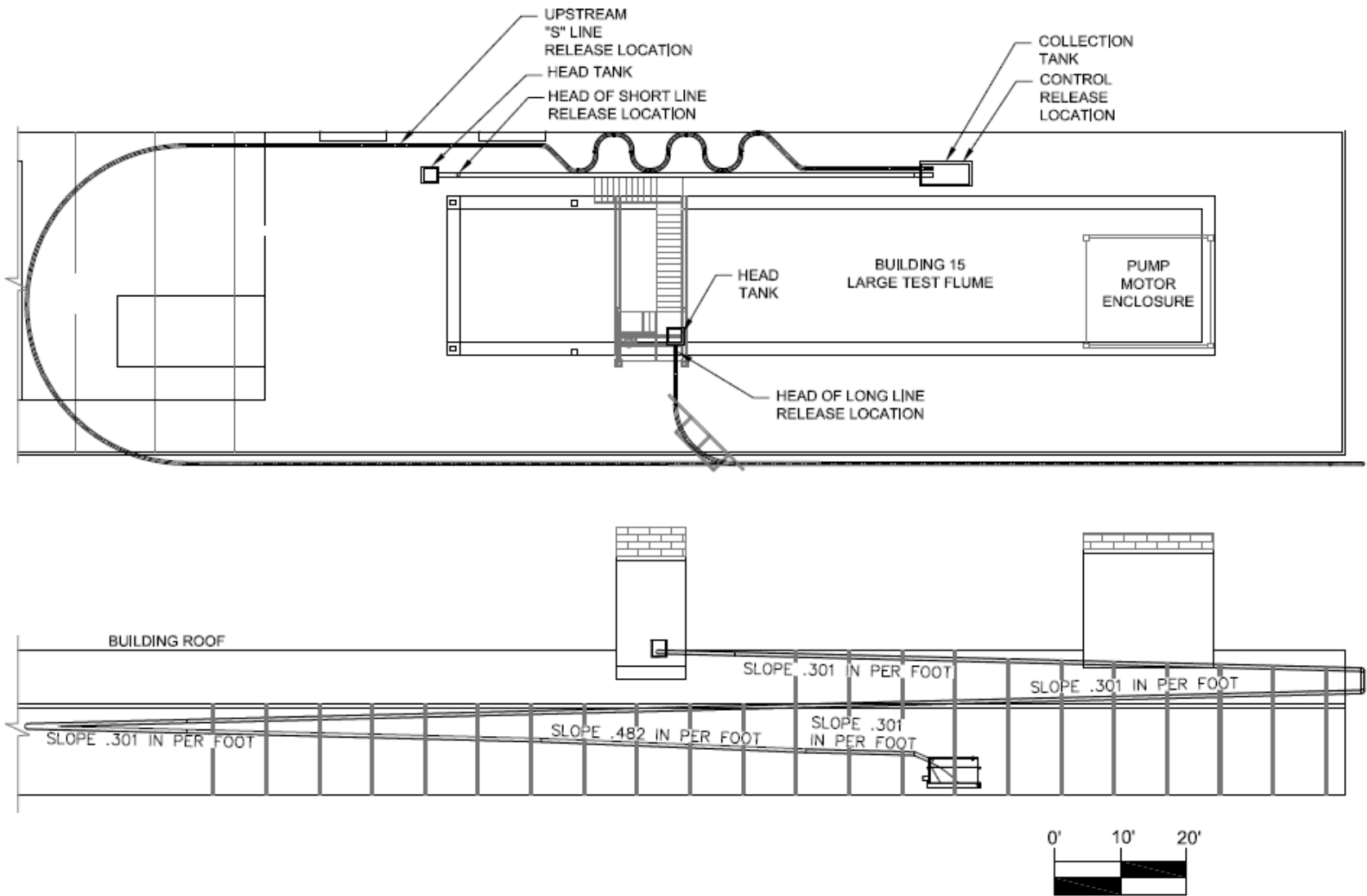
The phase two study was designed to determine the survival of fish exposed to increased return line length, drops, and wide and tight bends. Additionally, larger length classes were evaluated to supplement the initial database. For each species at a given size, 12 replicates were targeted (3 release locations) by (3 replicates per condition) plus (3 controls [1 per day/location]). The control was used to separate mortality associated with handling (removal from holding facility, counting into groups, collection from fish return, and post-processing of samples) from mortality associated with passage through the return line system. Initial and latent survival assessment methods were the same as those described above for phase one testing.

As with the phase one, survival for all species decreased during the transition from yolk-sac to post-yolk-sac larvae with the exact length varying among species. Survival increased rapidly with increasing fish length with a peak when larvae attained a size of approximately 12 mm (0.47 in.). Increasing the length (from 21.6 m [71 ft] to 131 m [430 ft]) of the fish return line and adding drops and bends did not affect survival within length groups.

A mortality event within the holding system reduced the number of bigmouth buffalo larval available in the lower length range (< 10 mm [<0.39 in.]), therefore a majority of the data for bigmouth buffalo was collected with juvenile fish (>14 mm [>0.55 in.]). This juvenile group showed consecutive weeks of high survival at approximately 100% for all release locations and controls which showed a strong relationship ( $P<0.0001$ ) between fish length and total survival, with larger buffalo exhibiting higher survival.

Bluegill (*Lepomis macrochirus*) total survival was found to be similar for all release locations (64 to 75%) throughout the study period and the statistical analysis revealed no significant differences in total survival by release location ( $P=0.2634$ ). In a comparison of fish length and control total survival there is a noticeable significant shift in increased survival from 12.5 to 17.5 mm (0.49 to 0.69 in.) in length.

Golden shiner total survival for treatment fish was moderate (67 to 81%) for all release locations. Plotting control survival against the daily length data confirms that survival was lower during the earlier weeks of testing when shiners were smaller and potentially more fragile. When total survival is plotted along with control survival at each fish length tested, results observed for the other species were also observed for golden shiner. The statistical analysis confirms that difference in total survival by length was significant and that as the larvae increase in length so does survival.

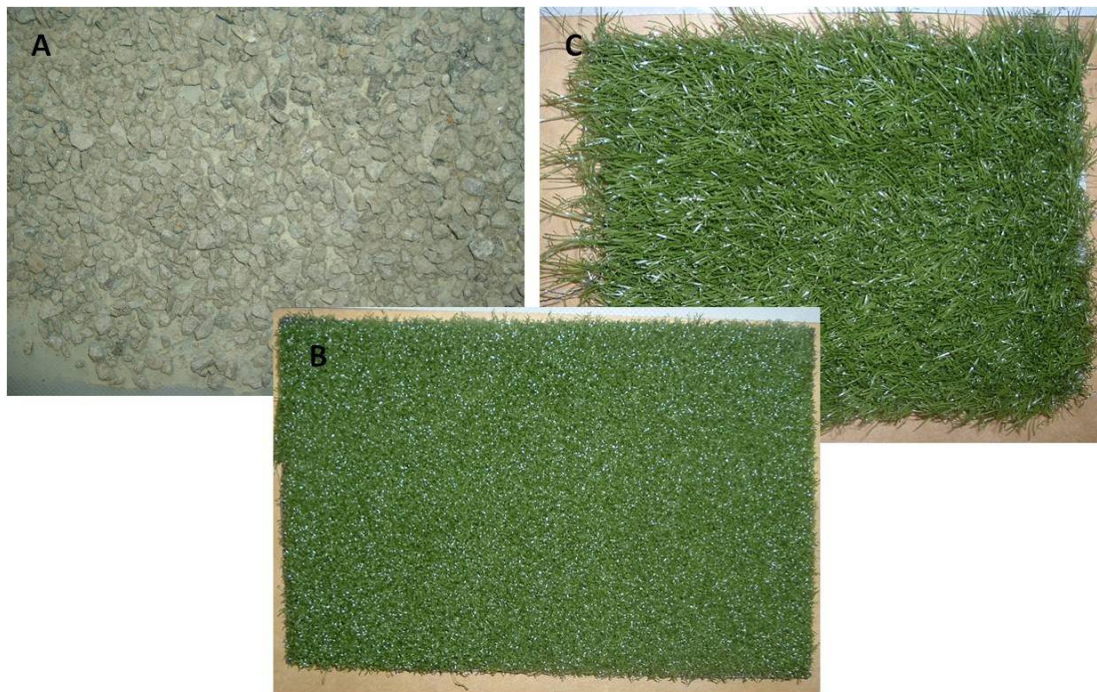


**Figure 2-39**  
**Plan and section view of the Phase II fish return line testing facility**

Common carp total survival was moderately high for all conditions; however the survival for the head of the long line location while lower (72%) it was not significant throughout the testing period. In a comparison of fish lengths and both daily test and control total survivals it is apparent that survival is highly variable below 9 mm (0.4 in.); however, once the carp reached a length range of 9.0 to 12.0 mm (0.4 to 0.5 in.) survival improved dramatically and remained nearly 100% through 20 mm (0.8 in.) in length. Length was a significant predictor of survival with larger fish experiencing greater total survival.

White suckers (*Catostomus commersonii*) were only available for a limited period of time and only used for shakedown testing of the phase two fish return system. Twenty-seven replicates were conducted with white sucker during the shakedown testing. There was very little variability in the average total survival regardless of release location (74 to 79%) and no statistical difference in survival between treatments and controls. With a limited length range tested over the study period (13.0 to 14.5 mm [0.51 to 0.57 in.]) it was not possible to determine a correlation between fish length and survival.

Phase three testing primary objective was to evaluate various trough substrates including a smooth, stone, rough carpet and a filamentous material (Figure 2-40). A parallel dual-trough system was constructed to allow control replicates (smooth trough) and treatment replicates (substrate trough) to use the same collection system, while maintaining similar velocities over the same distance, regardless of substrate. The smooth control trough remained unchanged throughout testing; however, the treatment trough could be configured with one of the three testing substrates. Each trough was 30.5 cm (12 in.) wide, 15.3 cm (6 in.) deep, and approximately 6.7 m (22 ft) long (Figure 2-41).



**Figure 2-40**  
**Stone (A), rough carpet (B), fiber (C) and smooth (not shown) trough substrate materials**

The collection box was approximately 1.0 m (3 ft 3 in.) wide, 1.0 m (3 ft 3 in.) deep, and 3.3 m (10 ft 10 in) long. A 25.4-cm (10-in.) diameter stand pipe with a valve was located on the upstream side of the collection tank behind an angled barrier screen (with 350- $\mu$ m mesh) to maintain water level. As with the previous fish return collection boxes this design allowed water to flow into and out of the collection box, retain collected organisms, and maintain water level.

Substrate survival testing was conducted with four species (Table 2-64) and broken into blocks by substrate. For each species at a given size, 15 replicates were targeted [(3 substrate treatments) by (3 replicates per treatment)] plus [(1 smooth trough control) by (3 replicates)] plus (3 collection box control [1 per test day/ 3 days per week]). To ensure that minimal fish growth occurred within a test block, all 15 replicates for a given species were completed within one test week.

Additional testing to evaluate the survival of fish being transported along with various types of debris was conducted with channel catfish and bluegill (Table 2-65). Debris testing was completed using only the smooth trough and with two debris groups. The first debris group (surrogate debris) included; Mylar, tinsel, and wood chips (Figure 2-42), which were selected as a surrogate for grass/filamentous algae, leaf, and woody organic materials traditionally found at a CWIS or within a fish return system. The materials selected for the second debris group (non-traditional debris) were chosen as an extreme case and were intended to create more injury and stress using non-traditional debris materials (Figure 2-43). This debris group included plastic media, plastic beads, and plywood pieces. For each species, 7 replicates were targeted (2 debris types) by (3 replicates) plus (1 control with debris).

During each testing type a control was used to separate mortality associated with handling (removal from holding facility, counting into groups, collection from fish return, and post-processing of samples) from mortality associated with passage through the trough system (with or without debris). Initial and latent survival assessment methods were the same as those described above for phase one testing.

**Table 2-64**

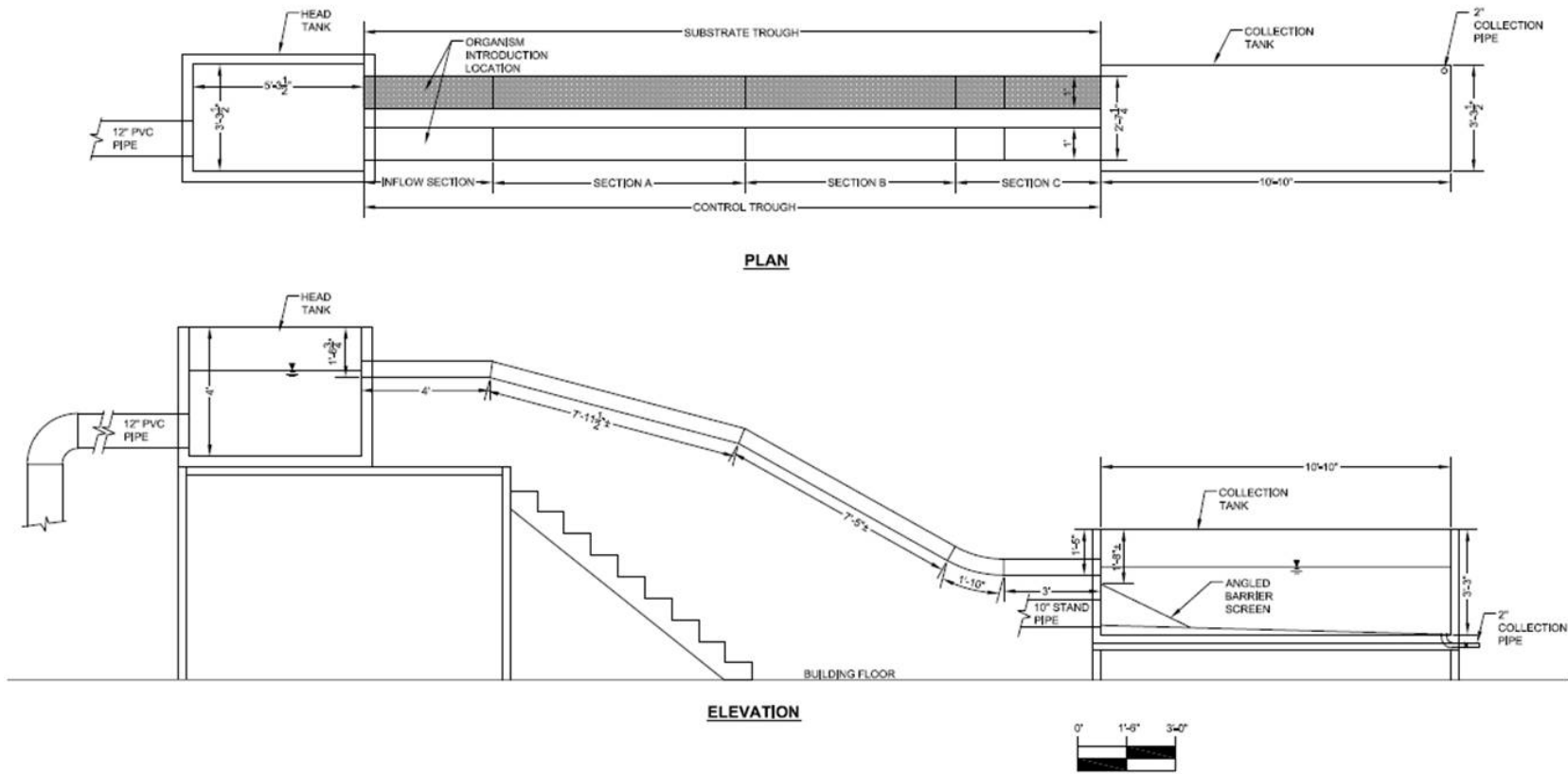
**Mean (with standard deviation), minimum, and maximum fish fork length (mm), and total number of treatment and control fish measured.**

| Common Name     | N     | Mean Length | Standard Deviation | Min  | Max  |
|-----------------|-------|-------------|--------------------|------|------|
| bluegill        | 2,092 | 26.8        | 5.0                | 10.0 | 40.0 |
| common carp     | 991   | 19.5        | 3.7                | 9.7  | 35.8 |
| channel catfish | 4,077 | 21.0        | 4.1                | 11.0 | 39.0 |
| golden shiner   | 1,144 | 15.9        | 7.3                | 6.6  | 44.0 |

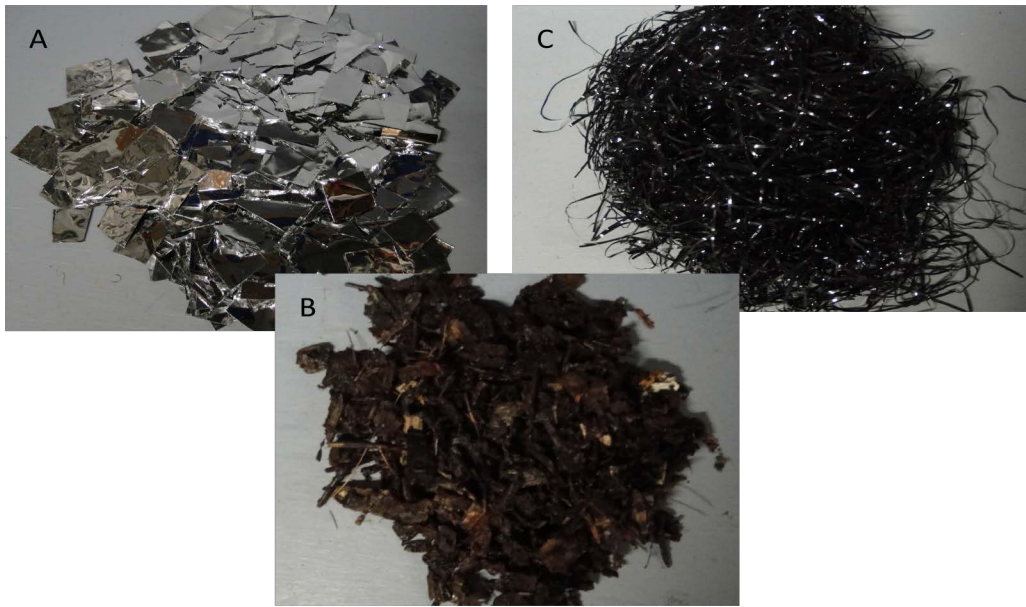
**Table 2-65**

**Mean (with standard deviation), minimum, and maximum fish fork length (mm), and total number of treatment and control fish measured.**

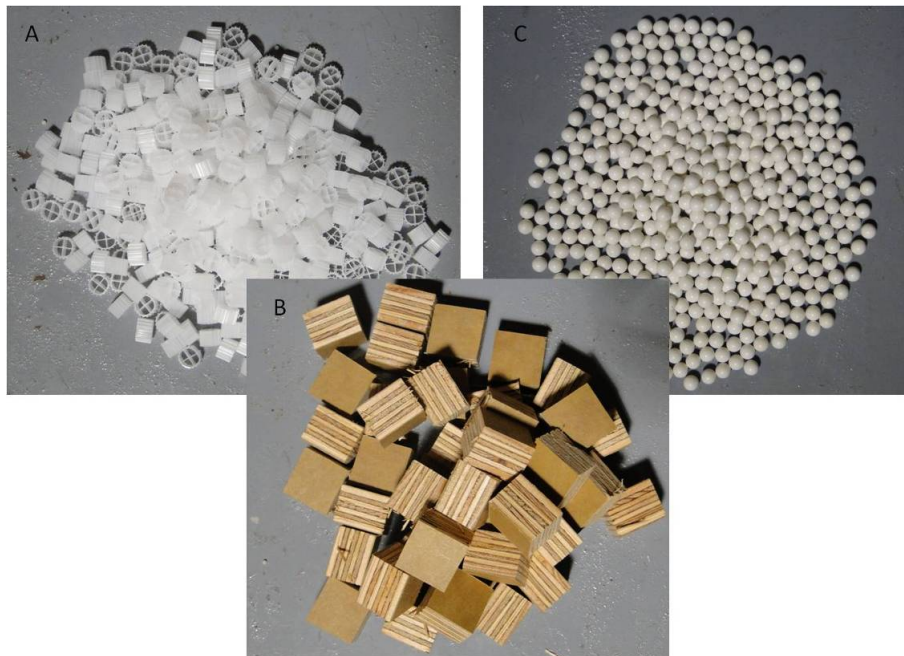
| Common Name     | N   | Mean Length | Standard Deviation | Min  | Max  |
|-----------------|-----|-------------|--------------------|------|------|
| bluegill        | 350 | 28.3        | 5.0                | 18.0 | 42.0 |
| channel catfish | 343 | 21.0        | 2.1                | 15.0 | 28.0 |



**Figure 2-41**  
**Plan and elevation views of the Phase III fish return testing facility**



**Figure 2-42**  
The surrogate debris group included mylar (A), wood chips (B), and tinsel (C) debris



**Figure 2-43**  
The non-traditional debris group included plastic media (A), plywood pieces (B), and beads (C) debris



Golden shiner was also tested over a broader range of body lengths than other species (6.6 to 44.0 mm [0.26 to 1.73 in.]), with the majority of the tested organisms measuring less than 20 mm (0.79 in.). Shiner experienced the highest mortality of all four species across all substrates tested; however the control groups experienced no mortality. While all treatments showed higher mortality than the control, during statistical analysis the median lengths of treatment fish in two cases were smaller than the control fish (rough carpet and smooth), in one case the median length was larger than the control fish (stone), and in one case was statistically no different in length than control fish (fiber).

Common carp had the highest survival rates of all the species tested exceeding 99% for all substrates. Lengths ranged from 9.7 to 35.8 mm (0.38 to 1.4 in.) with the majority of fish falling in the 16 to 20 mm (0.63 to 0.79 in.) range. None of the treatments were statistically different than the handling controls indicating that passage through the fish return substrates resulted in no additional mortality.

Mortality during bluegill substrate testing was relatively low in comparison to golden shiner, with no immediate mortality and total mortality of 1.4% or less for all treatments and controls. Bluegill were also tested over a broad range of lengths (10 to 40 mm [0.39 to 1.57 in.]); however, the majority were greater than 20 mm (0.79 in.). In comparisons of smooth and fiber trough with the control there was found to be no statistical differences in the median lengths of fish in these two treatments and the control group ( $P > 0.05$ ) indicating that survival was not influenced by fish length. Bluegill survival during debris testing was 100% for the control and the surrogate group and 98.6% for the non-traditional debris group, however this was no statistical different than the control. Fish lengths during the debris testing range from 18 to 42 mm (0.71 to 1.65 in.), with a majority of the fish (60%) tested measuring 20 to 30 mm (0.79 to 1.18 in.).

Channel catfish survival in the fiber trough was lower than the control, however the other three treatments (rough carpet, smooth, and stone substrate), there were no statistical differences between the treatments and the control. The fish lengths ranged 11 to 39 mm (0.43 to 1.53 in.); however, the majority of those tested (52%) were between 15 to 20 mm (0.59 to 0.79 in.). During debris testing catfish experience higher mortality than bluegill and were tested over a smaller length range (15 to 28 mm [0.59 to 1.1 in.]). An analysis of the data shows no statistical difference between survival between the control and treatment replicates which indicates that the addition of debris did not increase mortality.





# 3

## STATIONARY SCREENS

### Introduction

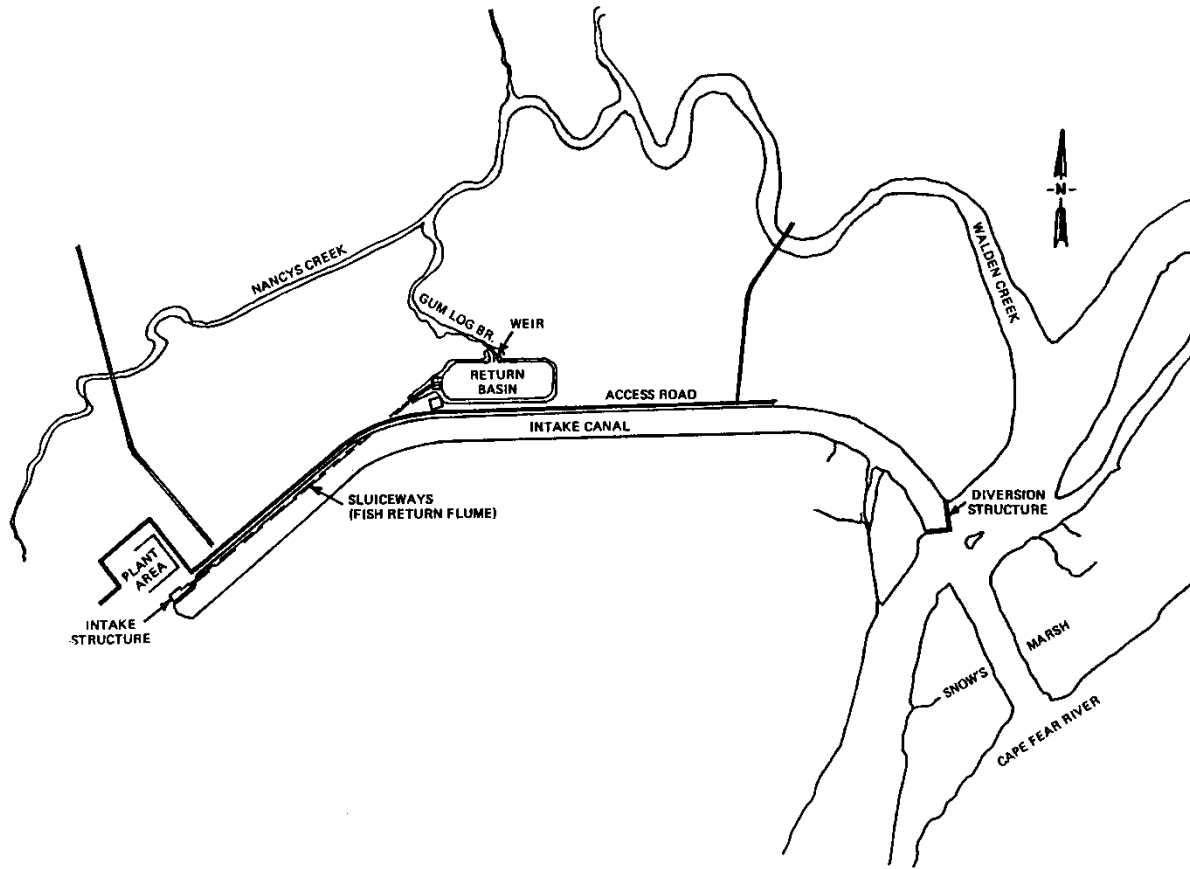
Stationary screens have had little application at power plant cooling water intake structures (CWISs). Though installations do exist, we found relatively little information regarding their biological effectiveness. For example, Units 1 and 2 at the Indian Point Generating Station on the Hudson River included fixed-screens of 9.5-mm (3/8-in) mesh at the entrance to the intake bays. Impingement monitoring was conducted from 1973 to 1975, but focused more on the characterization of fish impinged on the traveling screens than those impinged on the fixed-screens (Con Ed 1975). Other facilities, including Duke's Oconee, Marshall, and Belews Creek, have used stationary screens to protect pumping equipment and prevent the passage of impingeable sized fish; however, no biological performance data are currently available.

Except on small volume intakes, it is expected that challenges in maintaining fixed-screens in a clean condition, and thereby minimizing head loss, will preclude use of these screens. This is particularly true given the availability of other screening alternatives that require less maintenance, such as traveling screens, cylindrical wedgewire screens, and angled, flat-panel diversion screens (presented elsewhere in this report). However, for facilities seeking to take advantage of low through-screen velocity to meet 316(b) requirements, stationary screens may play an important role. In cases where the existing screen house is recessed from the source waterbody in a cove or fanned intake channel inlet, it may be possible to install stationary screens upstream of the existing traveling screens. Because these screens would be installed across a wider channel inlet, the screening area would be greater, resulting in lower through-screen velocities. O&M costs associated with debris removal from stationary screens may make such an installation prohibitively expensive at intakes with high debris or icing issues.

### Case Studies – CWIS Application

#### ***Brunswick Steam Electric Plant***

The Brunswick Plant is located in the Cape Fear estuary, approximately 9.2 km (5.7 mi) upstream from the mouth of the Cape Fear River (Figure 3-1). The plant consists of two generating units, each rated at 790 MW. Cooling water is drawn into the plant through a 4.8 km (3 mi) long intake canal. A V-shaped screen structure (referred to as a “diversion structure”) was installed in the fall of 1982 at the mouth of the intake canal and continues to effectively exclude larger juvenile and adult fish. An impingement study conducted in 1984 indicated that the barrier blocked juvenile and adult menhaden (*Brevoortia tyrannus*), spot (*Leiostomus xanthurus*), and croaker (*Micropogonias undulates*), while it did not exclude smaller bay anchovy (*Anchoa mitchilli*) (Carolina Power and Light 1985b).



**Figure 3-1  
Brunswick Plant layout and fish diversion barrier screen (Carolina Power and Light 1985b)**

As shown in Table 3-1, the diversion structure reduced the total number of organisms impinged on the traveling water screen by 43% when compared to the number impinged before the diversion structure was installed. The diversion structure reduced the total biomass impinged by 72%.

**Table 3-1**

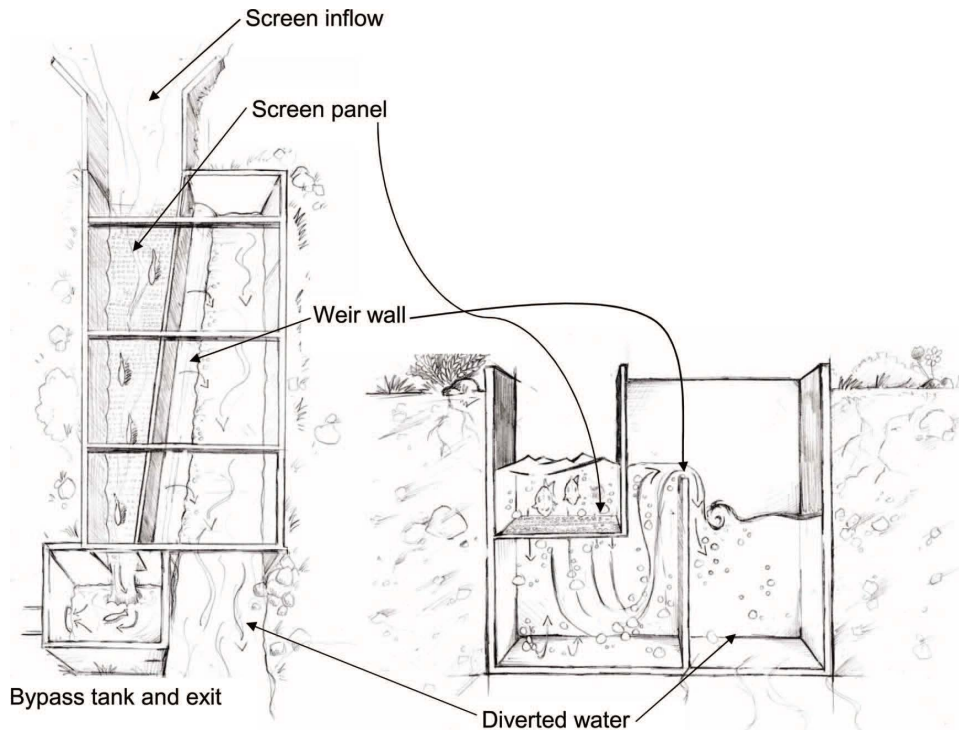
**Mean density and mean biomass of selected species impinged at Brunswick, 1977-1985 (from Thompson 2000). The period between 1977 and 1981 was before the installation of the diversion screen and the period between 1982 and 1985 was after.**

| Taxa                             | Density (#/million m <sup>3</sup> ) |              |                   | Biomass (kg/million m <sup>3</sup> ) |             |                   |
|----------------------------------|-------------------------------------|--------------|-------------------|--------------------------------------|-------------|-------------------|
|                                  | 1977-1981                           | 1982-1985    | Percent reduction | 1977-1981                            | 1982-1985   | Percent reduction |
| Atlantic menhaden                | 5,481                               | 395          | 93%               | 38.8                                 | 3.4         | 91%               |
| bay anchovy                      | 1,788                               | 4,261        | + 138%            | 2.5                                  | 3.7         | + 48%             |
| spot                             | 362                                 | 103          | 72%               | 3.7                                  | 1           | 73%               |
| croaker                          | 199                                 | 127          | 36%               | 1                                    | 0.7         | 30%               |
| blue crab                        | 351                                 | 251          | 28%               | 4.5                                  | 3.6         | 20%               |
| <b>Total organisms collected</b> | <b>10,538</b>                       | <b>5,971</b> | <b>43%</b>        | <b>60.6</b>                          | <b>17.3</b> | <b>72%</b>        |

## **Case Studies – Field Studies**

### ***Oxbow Fish Hatchery Cascade Locks, Oregon***

An evaluation of a horizontal flat-plate screen (Farmers screen) was conducted to determine its effectiveness at screening fish. The screen was designed by the Farmers Irrigation District in Hood, Oregon (Figure 3-2). The screening system directs intake water over the horizontal screen. A high ratio of sweeping velocity to approach velocity creates a sweeping effect, providing good self-cleaning, reduced effects on fish, and potentially lower installation and maintenance costs compared to screens with moving parts. A weir wall keeps a constant depth in the bypass channel. Fish and debris are swept into a bypass tank and are returned back to the source water body.



**Figure 3-2**  
**Plan and side conceptual views of Farmer screen (Mesa 2012)**

Evaluations were conducted at the Oxbow Fish Hatchery in Cascade Locks, Oregon. The screen at this location was designed to divert  $0.28 \text{ m}^3/\text{sec}$  (9.9 cfs) of water from Herman Creek, a tributary of the Columbia River. Hydraulic assessments determined velocities during biological evaluations.

Biological performance of the screen was assessed using juvenile coho salmon (*Oncorhynchus kisutch*) and steelhead (*Oncorhynchus mykiss*). The first of two investigations quantified short term mortality and injury to hatchery raised coho salmon exposed to the screen. Two size groups, large (85 to 145 mm [3.3 to 5.7 in.]) and small (54 to 78 mm [2.1 to 3.1 in.]), were tested. Approach velocity was set 0.2, 0.3, 0.4, and 0.5 m/sec (0.7, 1.0, 1.3, and 1.6 ft/sec). Groups of 8-10 fish were released 1 to 2 m (3.3 to 6.6 ft) upstream of the upper edge of the screen. All fish were collected in a sanctuary net located at the outfall of the bypass tank. Fish evaluated for injury were immediately euthanized while fish held for delayed mortality assessments were transferred to a holding tank. A fluorescein dye method was used to determine percent of body surface area injured. Mortality was observed for treatment and control fish after 24 and 48 hrs.

The second biological evaluation observed the behavior of yearling hatchery raised coho salmon and steelhead encountering the leading edge of the screen at approach velocities of 0.1, 0.2, and 0.3 m/sec (0.3, 0.7, and 1.0 ft/sec). A 34-m (111.5-ft) wooden flume was constructed in front of the screen to provide fish with distance between the release point and upstream edge of the screen. Groups of 7-10 fish were released in the upstream end of the flume at a set approach velocity. At 5-min periods, the number of fish who encountered the screen and either passed over or refused to pass over were recorded. Fish were allowed 20 min to migrate downstream and any fish remaining upstream were gently prodded downstream and collected after this time.

A total of 849 fish were tested for delayed mortality. There were no observed mortalities during any treatment condition after 24 and 48 hrs and one control mortality was observed. The percent of body area injured ranged from 0.5% to 2.5% for large fish and 0.4 to 3.0% for small fish. There were no severe injuries observed.

During behavioral tests, a total of 173 coho salmon and 102 steelhead were released. For all approach velocities, 75 to 95% of all coho salmon released approached and passed the screen within 5 min and 82 to 98% within 20 min. After 20 min, 3 to 18% of the fish remained in the flume. Steelhead passing the screen within 5 min ranged from 47 to 90% for all velocities and increased to 79 to 95% within 20 min. After 20 min, 5 to 21% of steelhead remained upstream of the screen.



# 4

## DRUM SCREENS

### Introduction

This chapter discusses drum screens that are used as physical barriers and those angled to the approach flow to guide fish to a bypass (i.e., a diversion system). While drum screens are a common screening technology world-wide, in the United States there are no installations for fish protection at cooling water intake structures (CWIS). A recent report prepared for EPRI (2012) by Electricité de France (EDF) reviews drum screen use in France at CWIS including some performance information for minimizing impingement mortality. However, in the U.S., drum screens have been used extensively to block fish passage at hydroelectric and irrigation facilities. Some of these installations have not been biologically effective due to poor orientation and/or lack of escape routes. As a result, most of the later drum screen installations have been set at an angle to the flow to divert fish to bypasses. Replacement of many of the existing angled drum screen installations with angled flat-panel screens is being considered.

### Rotary Drum Screens

Rotary drum screens, such as those shown in Figure 4-1, are used at many small water diversions. The screens often have bypasses at their ends. The drum is operated approximately 70 to 80% submerged, and debris is carried over or enters the fish bypass. If the submergence drops much below 70%, debris accumulation and plugging become problems. Therefore, relatively constant water surface elevation is required with drum screens. In the past 20 years, many of these screens have been replaced with angled drum or flat-panel screens that actively divert fish to a bypass.

### Angled Rotary Drum Screens

Angled drum screens have provided effective downstream protection for juvenile salmonids at a variety of hydroelectric and irrigation facilities in the Pacific Northwest (Neitzel et al. 1990). The angled design of drum screens was developed to reduce fish impingement and to improve guidance to a bypass. Like angled flat-panel screens, suitable hydraulic conditions at the screen face and a safe bypass system are required for the screens to effectively protect fish from entrainment and impingement and to divert them to a bypass for return to the main stem river channel. Suitable hydraulic conditions include uniform approach velocities, a velocity of about 0.15 m/sec (0.5 ft/sec) or less for the normal velocity component (the component perpendicular to the screen face), a velocity component along the screen that is at least twice the magnitude of the normal component, and a relatively constant submergence (Haider and Nelson 1987; Johnson 1988; Pearce and Lee 1991). If the screens are not properly installed and maintained, unfavorable flow conditions can occur, and effective fish protection and guidance by the screens can be reduced. Otherwise, the angled drum screen can be considered for use as a fish protection device. However, in the Pacific Northwest, the current trend in fish screening is the use of flat-panel angled screens instead of drum screens. Angled drum screens continue to offer protection for fish in the Pacific Northwest, primarily at irrigation and hydroelectric diversions. These

screens appear to be operating mostly as designed. Routine maintenance is required to ensure that velocity, screen submergence, and screen-sealing criteria continue to be met over time. As stated previously, angled flat-panel screens are being favored over angled drum screens for new facilities at this time. However, the biological data resulting from studies of these screens is applicable to angled screens in general and can be used in evaluating the potential for application of angled fixed or traveling screens (discussed previously) at CWISs.

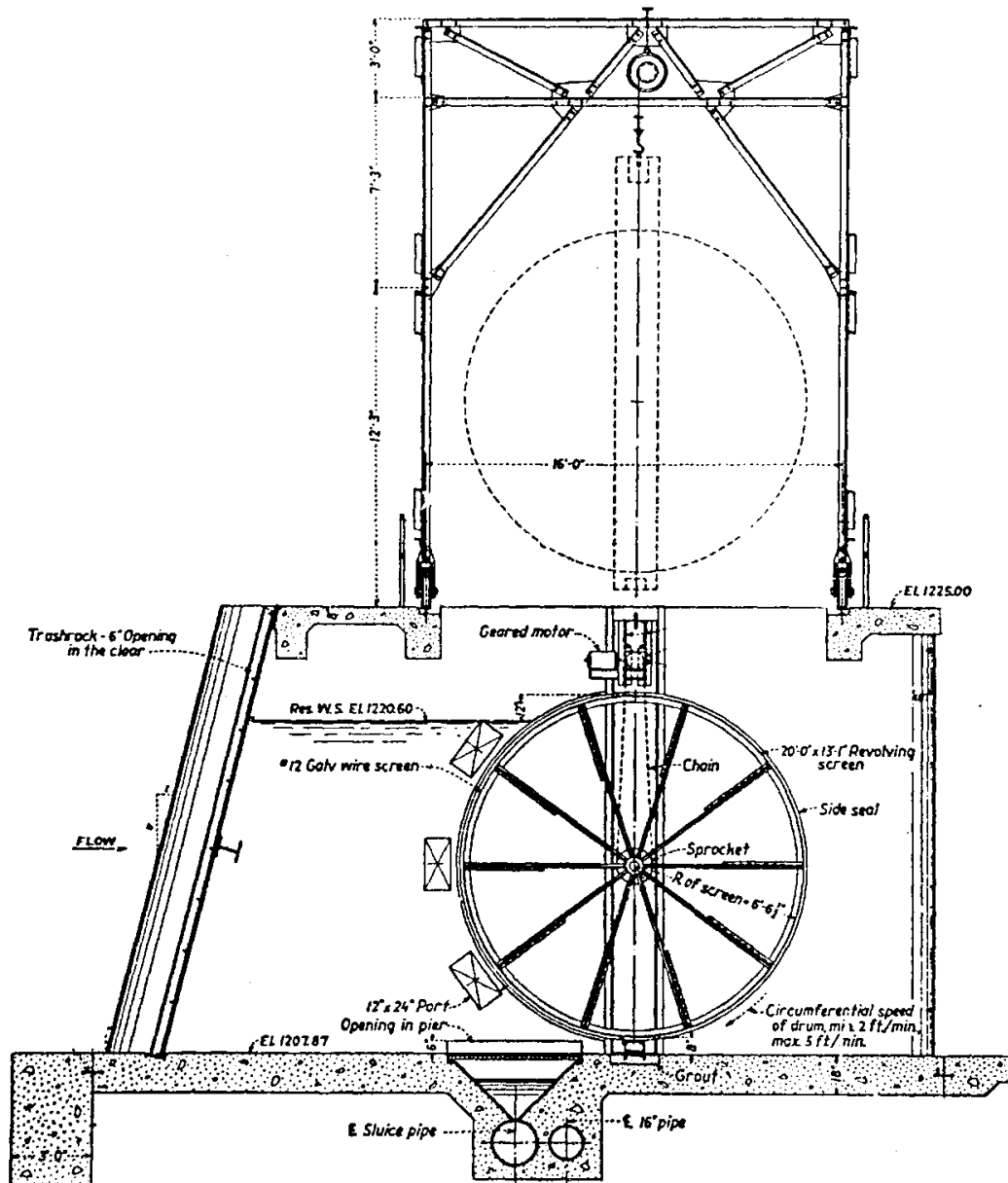


Figure 4-1  
Typical drum screen (EPRI 1986a)



## **Case Studies – Rotary Drum Screens - Water Diversion Field Tests**

### ***Eagle Point Irrigation District***

The Eagle Point Irrigation District diverts 2.6 m<sup>3</sup>/sec (90 cfs) from South Fork Big Butte Creek, Oregon, through a drum screen oriented perpendicular to the flow. The facility was installed in 1957 to protect steelhead smolts and resident rainbow trout (*Oncorhynchus mykiss*). It is operated continuously from spring through fall. Screen mesh size is 0.6 cm (1.4 in.), and approach velocities are 0.6 to 0.9 m/sec (2 to 3 ft/sec). This screen operates effectively under all flow conditions, seasons, and times of day (EPRI 1986a).

### ***Irrigation Canal No. 1, City of Yakima, WA***

The City of Yakima also operates drum screens to screen the flow into city irrigation canal No. 1. Fish species of concern include coho [*Oncorhynchus kisutch*], Chinook [*Oncorhynchus tshawytscha*], and steelhead [*Oncorhynchus mykiss*]. Screen mesh size is 0.6 cm (0.25 in.), and screen approach velocity is about 0.3 m/sec (1 ft/sec). These screens are effective under all conditions (EPRI 1986a).

### ***Patterson Irrigation District***

The Patterson Irrigation District withdraws 1.4 m<sup>3</sup>/sec (50 cfs) from the San Joaquin River (California) through a drum screen oriented perpendicular to the flow. This screen was installed in 1978 and is operated continuously from March through October. Fish species of concern include all life stages of salmonids. Screen mesh size is 0.3 cm (0.1 in.), and screen approach velocity is 0.1 m/sec (0.33 ft/sec). Although no data are available, the district believes the screen is highly effective in preventing salmonid entrainment (EPRI 1986a).

### ***Pacific Power and Light***

Pacific Power & Light (PP&L) installed drum screens at its Lemolo Units 1 and 2 on the North Umpqua River (Oregon) to protect downstream migrant salmonids. Due to severe plugging with "moss" and other debris, the screens do not operate. PP&L has also operated drum screens at two diversions from the Naches River (Oregon) since 1936. These screens are oriented perpendicular to the flow and are designed to protect coho (*Oncorhynchus kisutch*), Chinook (*Oncorhynchus tshawytscha*), and steelhead (*Oncorhynchus mykiss*) smolts. While not functional under severe icing conditions, they are generally reliable and have approach velocities less than 0.3 m/sec (1 ft/sec). The screens meet all passage criteria except for fry. PP&L is developing a study plan for further screen evaluation. A third location at which PP&L operates drum screens (perpendicular to flow) is at its Prospect No. 3 hydroelectric plant on the South Fork Rogue River (Oregon). These screens have been operated since 1932 and are designed to protect resident brook (*Salvelinus fontinalis*), brown (*Salmo trutta trutta*), and rainbow trout (*Oncorhynchus mykiss*). The facility is effective under all conditions except icing, and there have been some problems with its paddle drive mechanism. The latter two sites are operated continuously from spring through fall (EPRI 1986a).

## **Various Sites – Idaho**

The Idaho Department of Fish and Game (City Water, Light, and Power Company 1981 as cited in EPRI 1986a) oversees approximately 30 sites with rotary drum screens on irrigation diversions where anadromous fish are present. The State is very pleased with these systems' effectiveness (observations indicate essentially 100% passage/survival), and nearly all new passage systems are the rotary drum type. Drums are set perpendicular in low-flow diversions and angled in higher-flow diversions.

### **Woodbridge Fish Facility**

The Woodbridge fish facility on the Mokelumne River, California, is a horizontal rotary drum screen installation. The facility consists of seven 3-m (10-ft) diameter by 1.98 m (6.5 ft) wide drums with 0.63-cm (0.25-in.) mesh screen. The approach velocity at a flow of 12.7 m<sup>3</sup>/sec (450 cfs) is 0.18 m/sec (0.6 ft/sec). Study results under these conditions showed that salmon as long as 40 mm (1.6 in.) could pass through the mesh screen. To avoid such losses, it was recommended that screen slot width not exceed 0.24 cm (0.09 in.) to prevent passage of Chinook salmon (*Oncorhynchus tshawytscha*) longer than 30 mm (1.2 in.), as well as American shad (*Alosa sapidissima*) longer than 26 mm (1.0 in.) and white sturgeon (*Acipenser transmontanus*) longer than 24 mm (0.9 in.) (Odenweller and Brown 1982).

### **Glenn-Colusa Irrigation District**

The California Department of Fish and Game installed rotary drum screens at the Glenn-Colusa Irrigation District irrigation diversion on an oxbow of the Sacramento River, California, in the early 1970s. Forty horizontal drum screens are oriented parallel to the shoreline at the mouth of the irrigation canal. Each drum is 5.2-m (17-ft) in diameter and 2.4 m (8 ft) wide and is covered with #4 woven stainless steel wire cloth. Mesh openings measure 4.3 mm (0.17 in.). There is a fish bypass located at the downstream end of every fourth drum (10 bypasses total), and each bypass is 15.2 cm (6 in.) wide. The bypasses join and lead to a bypass outlet, which is downstream of a diversion dam located on an oxbow below the irrigation canal. A trash rack is located in front of the screens. The screens are operated (using hydraulic pumps) continuously during the irrigation season (approximately April 15 to November 1). Design approach velocities are 0.2 m/sec (0.8 ft/sec). Studies by Decoto (1978) using marked fingerling Chinook salmon (*Oncorhynchus tshawytscha*) indicated an unknown number of salmon are lost through the screens at Glenn-Colusa, due possibly to mesh passage or seal leakage. However, test and wild Chinook fingerlings used drum bypasses as indicated by their capture in nets at the bypass outlet. Decoto (1978) suggested that bypass system efficiency may have been limited by the narrow bypass width (15 cm [6 in.]), the gravity-flow operation, and sediment accumulation in the drum bypasses. The primary problem has been a degrading stream bed that prevents fish access to the bypasses at low flows. The rotary drum screens were eventually replaced with a flat-panel diversion screen.

### **Savage Rapids Diversion System**

Grants Pass Irrigation District operates revolving drum screens in a gravity canal that is part of the Savage Rapids Diversion system (Rogue River, Oregon). Gravity flow diverts water to the canal head works. The system is designed to prevent all fish that may be present from entering

the canal. Species of concern include spring and fall Chinook (*Oncorhynchus tshawytscha*), summer and winter steelhead (*Oncorhynchus mykiss*), coho (*Oncorhynchus kisutch*), and trout. The screens are operated continuously during the summer (Bureau of Reclamation 1976, 1979). Mesh size of the screens is 0.6 cm (0.25 in.), and approach velocities are about 0.6 to 0.9 m/sec (2 to 3 ft/sec). The rotary screens provide good fish protection, with minimal mortalities. The screens are reliable from an engineering viewpoint and are effective under all conditions (although some algal clogging does occur).

## **Case Studies – Rotary Drum Screens – Hydroelectric Field Tests**

### ***White River Hydroelectric Plant***

Puget Sound Power and Light Company (PSP&L) has diverted 57 m<sup>3</sup>/s (2,000 cfs) of the White River through a drum screen oriented perpendicular to flow at its White River Hydroelectric Plant since 1938. The operation schedule is continuous from March through November. The screen is designed to protect Chinook (*Oncorhynchus tshawytscha*), coho (*Oncorhynchus kisutch*), and steelhead (*Oncorhynchus mykiss*) smolts from entrainment. Survival of 0-age smolts has been variable but has dropped as low as 10%. Survival of yearlings is about 90%. Screen mesh size is 0.6 cm (0.23 in.), and screen approach velocity is 0.5 m/sec (1.5 ft/sec). This facility has been replaced by an angled, fixed-screen diversion and bypass system (EPRI 1986b).

### ***Sizewell Power Station***

The Sizewell Nuclear Generating Station (Units A and B) is located on the east coast of England and withdraws once-through cooling water from the North Sea. Both units have offshore intakes and onshore drum screens. The Sizewell B intake tunnel was extended further offshore and capped to reduce aquatic impact. The Sizewell B screens (10 mm [0.4 in.] square mesh) were designed with fish protection features that included; continuous rotation, higher rotating speeds, fish buckets and a semi-circular smooth fish return line. The fish return line discharges into the cooling water discharge system (Turnpenny and Taylor 2000).

To assess the biological efficacy of the screen improvements at Sizewell B, collections off the screen were made every 15 to 20 min by diverting the fish return water to the trash baskets. Test animals were separated from the screen wash-water flow at the point of entry using a fine-mesh Netlon© chute. This chute leads to a tank of sea water where samples were collected. After being exposed to the return system, fish were held in a fish transport trailer equipped with four 80 L circular tanks. Fish were exposed to chlorinated water at 40°C (104°F) (10°C [50°F] above ambient seawater temperatures) for 10 min to simulate maximum passage time in the heated discharge which provided a worst case scenario. Subjects were held for 24 hrs and then assessed for mortality.

Survival of commercially important species was; flounder (100%), plaice (100%), sole (96.1%), cod (93.6%), bass (89.2%), dab (80.0%), whiting (47.8%), sprat (0.0%), herring (0.0%), and shrimp (94.3%). Overall, the fish and trash return system was an improvement over the Sizewell A intake. Species-specific mortality could have been due to variable physiological tolerances. In the case of the whiting, high mortality was probably attributed to burst swim bladders that occurred in 35% of the cases. Flat-fish species had a higher survival because of less surface abrasion compared to more fragile pelagic fish.

## **Case Studies – Angled Rotary Drum Screens – Water Diversion Field Tests**

### ***Yakima River Basin***

Blanton et al. (1998) provide a review of angled screen evaluations conducted at 19 sites in the Yakima River basin to assess whether they are being maintained in a way that promotes safe fish passage. Twelve of the sites have rotary drum screens, six have vertical plate screens, and one site has vertical traveling screens. The evaluations included measurements of approach and bypass velocities, checking screen seals, checking screen submergence, and identifying conditions in the screen and bypass outfall areas that might increase predation. Evaluations were conducted three times at each site between early May and mid-August of 1997. Water velocities were measured in front of the screens and in the bypasses. Underwater video techniques were used to assess screen seal condition, debris accumulation, and fish presence. Auxiliary data were collected to assess facility equipment and operational conditions as related to effective downstream fish passage. Fish presence downstream of screens at nine of the sites was evaluated using fyke nets with 0.3-cm (1/8-in.) knotless netting. Nets typically were placed immediately downstream of diversion canal head gates.

In general, water velocities at each screening facility were determined to meet Pacific Northwest standards set by the NMFS (Rainey 1985; Pearce and Lee 1991). At least 10% of approach water velocity measurements at seven of the screening facilities exceeded the NMFS requirement of 0.15 m/sec (0.4 ft/sec). Gaps in seals or other components that may allow fish to pass through screen facilities were identified at 10 of the sites. The submergence level of screens at many of the facilities exceeded 85%, and one screen was submerged less than 65%. There is a risk of fish passing over screens if submergence levels exceed 85%; self-cleaning can be hindered if levels go below 65%. Water depth at bypass outfalls were inadequate (i.e., too shallow) at four of the facilities. Shallow water at bypass exits typically was observed during August when river flows were low and fish movement was minimal. Using underwater video, observations of large fish and habitat characteristics (i.e., types and amount of cover) that may be conducive to predator presence were used to determine potential predation risks. Five sites were determined to have relatively high potential for salmonid predation losses based on observations of large fish and considerable amounts of woody debris at the screens. Removal of woody debris from the base of drum screens was recommended to reduce predation risks. Maintenance and operation of screening facilities was considered adequate for most sites. Removal of accumulated sediment and woody debris was cited as a maintenance procedure that should be improved to minimize adverse hydraulic conditions and predation potential.

# 5

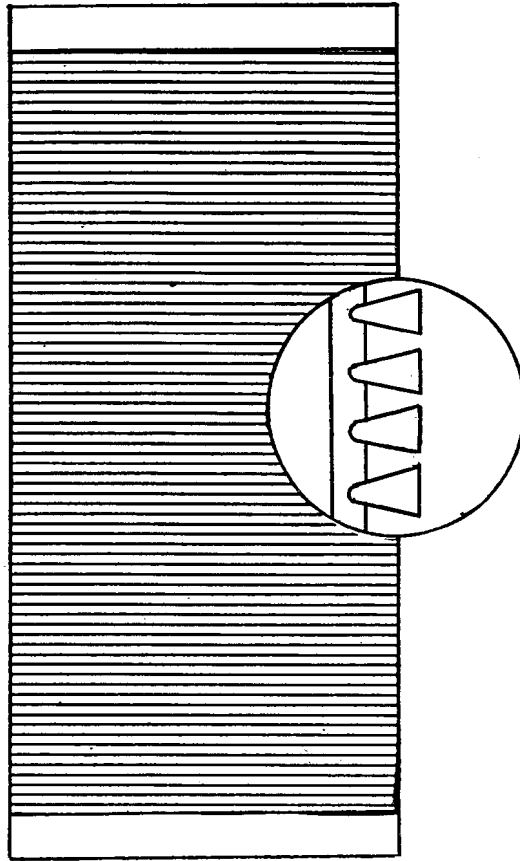
## CYLINDRICAL WEDGEWIRE SCREENS

### Introduction

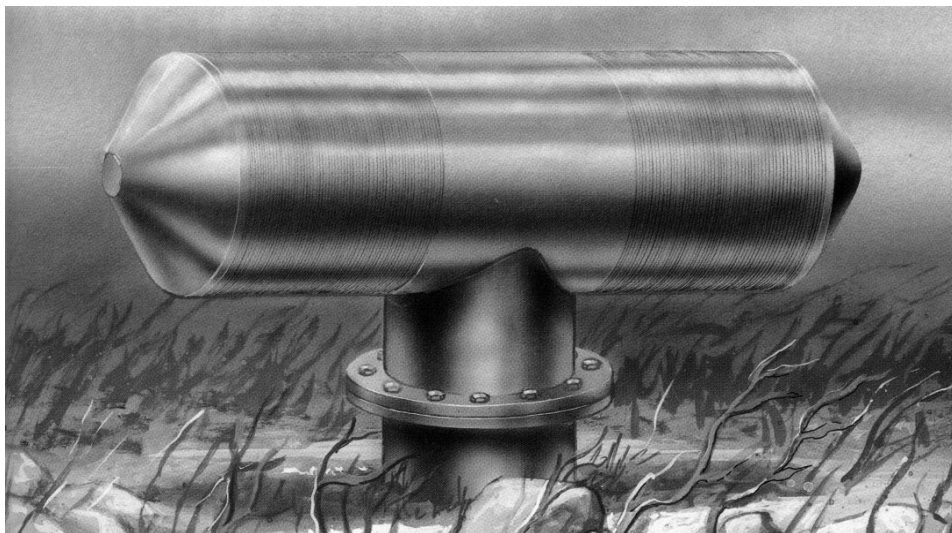
Wedgewire screens have the potential to reduce both entrainment and impingement at water intakes. Wedgewire screens use V or wedge-shaped cross-section wire welded to a framing system to form a slotted screening element (Figure 5-1). In order to maximize the ability of wedgewire screens to reduce impingement and entrainment, the following conditions are preferable:

- Sufficiently small screen slot size to physically block passage of the smallest life stage to be protected (typically 0.5 to 1.0 mm);
- Low through-slot velocity;
- Ambient currents that are sufficient for sweeping aquatic organisms and debris past a screen

Wedgewire screens (Figure 5-2) have been effective in preventing entrainment and impingement of ichthyoplankton and juvenile fish at different types of water intakes (mainly irrigation, municipal water supply, and cooling water intakes) without any major maintenance problems. However, as with any screening technology, the potential for clogging and biofouling is a concern and needs to be addressed in the design and operation of this technology. When all conditions for effective operation are met, wedgewire screens can reduce entrainment and impingement to levels that usually meet existing regulations and resource agency criteria. Wedgewire screens would meet the Proposed 316(b) Rule for impingement mortality reduction, because the design through-slot velocity is less than 0.15 m/sec [0.5 ft/sec].



**Figure 5-1**  
Cylindrical wedgewire screen panel detail (modified from EPRI)

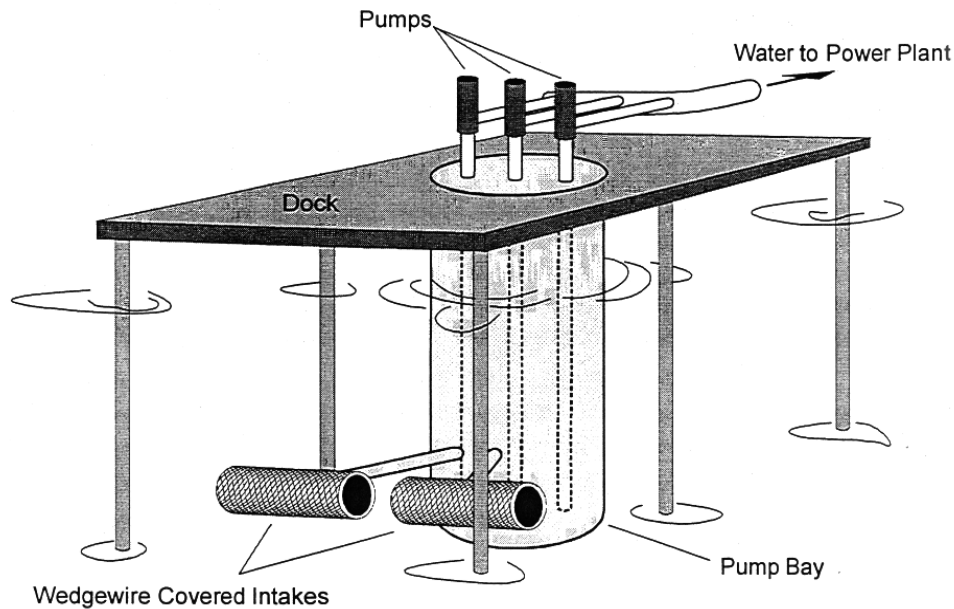


**Figure 5-2**  
Cylindrical wedgewire screen intake (courtesy of Johnson Screens)

## Case Studies – CWIS Application

### Logan Generating Plant

A study was conducted to evaluate the performance of 1-mm (0.039 in.) slot wedgewire screens at the Logan Generating Plant (LGP; Ehrler and Raifsnider 2000) (Figure 5-3). The plant is located on the Delaware River in Gloucester County, New Jersey. Water is drawn from the river to replace evaporative water losses from the plant's closed-cycle cooling system.



**Figure 5-3**  
**Wedgewire screen intake at the Logan Generating Plant (Ehrler and Raifsnider 2000)**

Samples were collected from the Delaware River adjacent to the plant and from water that had passed through the wedgewire screens for comparison of larval densities. River water was sampled by towing a plankton net at water depths of 10.4, 8.5, and 6.7 m (34, 28, and 22 ft). Samples from the river were collected by towing a 30-cm (1-ft) diameter, 335- $\mu$ m mesh plankton net at constant speed. Three sampling transects were established: one was located upriver of the station, another was aligned with the plant's fuel dock, and one was located downstream of the plant. Water that had passed through the screened intake was sampled by pumping water from the plant's intake wet well. A total of 30 towed net and entrainment samples were collected.

The most abundant species collected during tow samples in the deep stations (9.1 m [30 ft]) were striped bass (*Morone saxatilis*) (39%), white perch (*Morone americana*) (28%), carps/minnows (Cyprinidae) and suckers (Catostomidae) (19%), and herrings (Clupeidae) (13%). The most abundantly collected species at the shallow stations (0.9 m [3 ft]) were river herring (*Alosa pseudoharengus* and *Alosa aestivalis* 80%), white perch (17%), striped bass (2%), and carps/minnows and suckers (1%).

A comparison between the densities of striped bass in the Delaware River and in the plant's makeup water was used to determine the effectiveness of the wedgewire screen intake system. It

was estimated that an unscreened intake would entrain approximately 0.03% of the local striped bass larval population. The intake screens were expected to exclude 90% of the striped bass larvae (Ehrler and Raifsnider 2000). The results of the comparison study resulted in an average proportional withdrawal of striped bass larvae of 0.003%.

### **Cope Station**

A cylindrical wedgewire screen intake system is in operation at the 385 MW, coal-fired Cope Station located on the South Fork Edisto River in Orangeburg County, South Carolina (Cumbie and Banks 1997). The station withdraws 0.3 m<sup>3</sup>/s (10 cfs) for closed-cycle cooling purposes. Engineering and model studies were conducted to demonstrate the system's potential to minimize impingement and entrainment of fish (including eggs, and larvae). Species of primary interest included redbreast sunfish (*Lepomis auritus*), striped bass (*Morone saxatilis*), and shortnose sturgeon (*Acipenser brevirostrum*).

The intake structure consists of two, 2-mm (0.079 in.) slot cylindrical wedgewire screens. The screens are affixed to two 0.6 m (24-in.) diameter pipes that project out from a caisson intake structure. They are arranged in line, with their long axis parallel to the river flow. Through-slot velocities were found to be a maximum of 0.15 m/sec (0.5 ft/sec). It was concluded that potential negative impacts of the screens on eggs and larvae was low because the cross-sectional area of the river was large relative to area influenced by the intake (i.e., probability of organisms encountering the intake screens was low). The lateral distance over which the screens exert an entraining influence on the river was determined to be approximately 8% of the stream width at the intake location. No data were presented with respect to the biological effectiveness of the screen (i.e., impingement or entrainment rates).

### **Eddystone Generating Station**

Cylindrical wedgewire screens were installed for fish protection purposes at the Eddystone Generating Station located on the Delaware River (within the tidal influence) near Philadelphia, Pennsylvania (Veneziale 1991). The four-unit Eddystone station has a generating capacity of 1,400 MW. The screens were installed in front of the cooling-water intakes of Units 1 and 2, which have a combined flow of about 27.8 m<sup>3</sup>/sec (980 cfs). The Eddystone Station originally had trash racks and traveling water screens for collecting fish and debris. Impingement and entrainment studies revealed that over 3,000,000 fish were impinged on the traveling screens during a single 20-month period. It was concluded that Delaware River resident and migratory fish populations were being adversely affected by the Eddystone Plant. Consequently, resource agencies requested that steps be taken to reduce fish impingement at Eddystone as part of the facility's 316(b) requirements. After an extensive review of available fish protection technologies, the facility chose cylindrical wedgewire screens to replace the existing screens on the basis of past experience and low maintenance costs.

To support the wedgewire screens, a sheetpile bulkhead was installed at the intake. Sixteen cylindrical screens were placed in front of the Unit 1–2 intake structure and perpendicular to the bulkhead (Figure 5-4). The screens are arranged in two rows: eight inboard screens extend 2.1 m (7 ft) out from the bulkhead and eight outboard screens extend 5.8 m (19 ft) out. The screens can be removed for manual cleaning, and an air-burst cleaning system was installed to facilitate debris flushing without removing the screens. Since the screens have been installed, minimal



debris accumulation has occurred and there has been no visible damage. The air-burst cleaning system is used infrequently and the screens have experienced no problems with ice buildup. It has been concluded that fish impingement and screen fouling have been eliminated at Eddystone (Veneziale 1991).

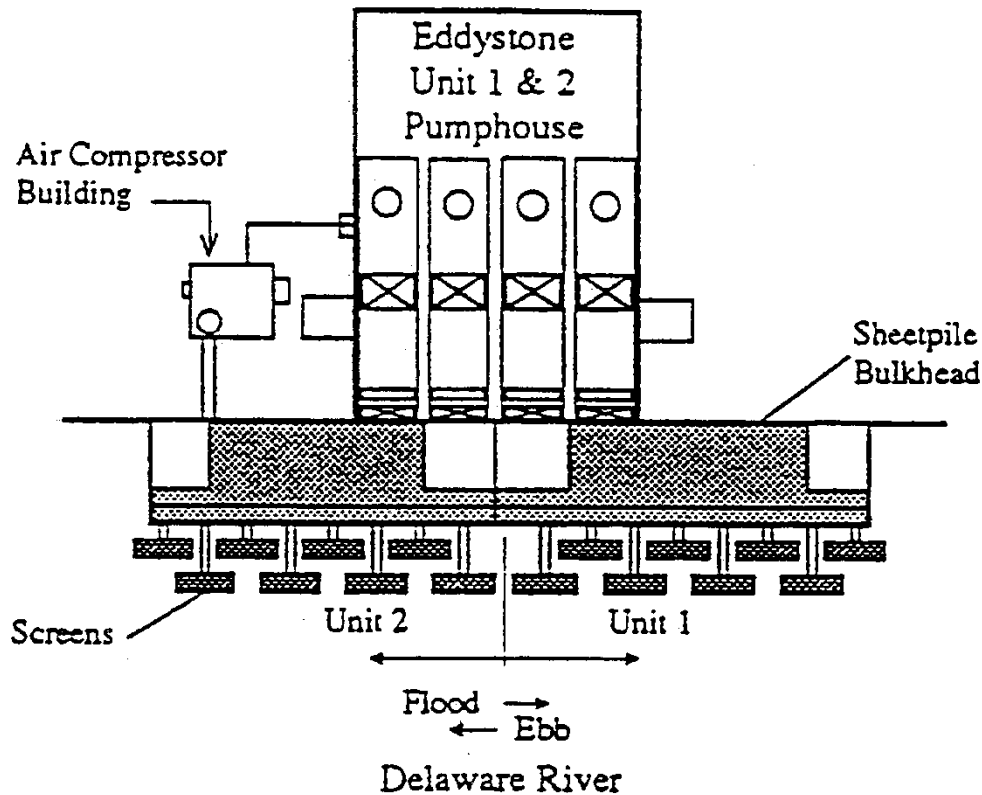


Figure 5-4  
Wedge wire intake system at Eddystone Station (Veneziale 1991)

### **Jeffrey Energy Center**

A cylindrical wedge wire screen cooling water intake system has been operating since 1982 at the Jeffrey Energy Center (JEC) located on the Kansas River in Kansas (Johnson and Ettema 1988). The JEC has three 670 MW units that employ a closed-cycle cooling system. Replacement water for the cooling system is withdrawn from the Kansas River. The river intake system was designed to withdraw up to 3.1 m<sup>3</sup>/sec (111 cfs), remain free of floating debris, have a sediment-free area around the screens, withdraw water during low flow periods, and have low maintenance requirements (Figure 5-5).

Two screen types were considered for installation at the JEC intake: traveling screens (active screening) and cylindrical wedge wire screens (passive screening). Through-flow traveling screens have been installed at other Kansas River water intakes. These screens have operated efficiently; however, wearing of key parts has contributed to extensive maintenance requirements. Passive screen systems possess no moving parts that can wear or require extensive

maintenance. Also, low water velocity between screen wires of cylindrical screens reduces the potential for fish impingement and entrainment. For these reasons, the cylindrical wedgewire screens were chosen for installation with the new intake system at JEC.

The screen system that was installed at JEC comprises three cylindrical wedgewire screens placed along the face of the intake structure (Figure 5-5). The screens are 1.2 m (4 ft) in diameter, about 3.4 m (11 ft) in length, have slot openings of 10 mm (0.375 in.), and have a flow capacity of 1.0 m<sup>3</sup>/sec (37 cfs), which maintains a 0.15 m/sec (0.5 ft/sec) through-slot velocity. The screens are capable of being removed for inspection and maintenance. An air backwash system was installed for screen cleaning. The intake system has been operating for several years with minimal problems. The screens have been free of sedimentation and debris accumulation. Maintenance has consisted of daily sediment sluicing and air backwashing and annual sediment basin dredging. No information was provided with respect to the biological effectiveness of the screens.

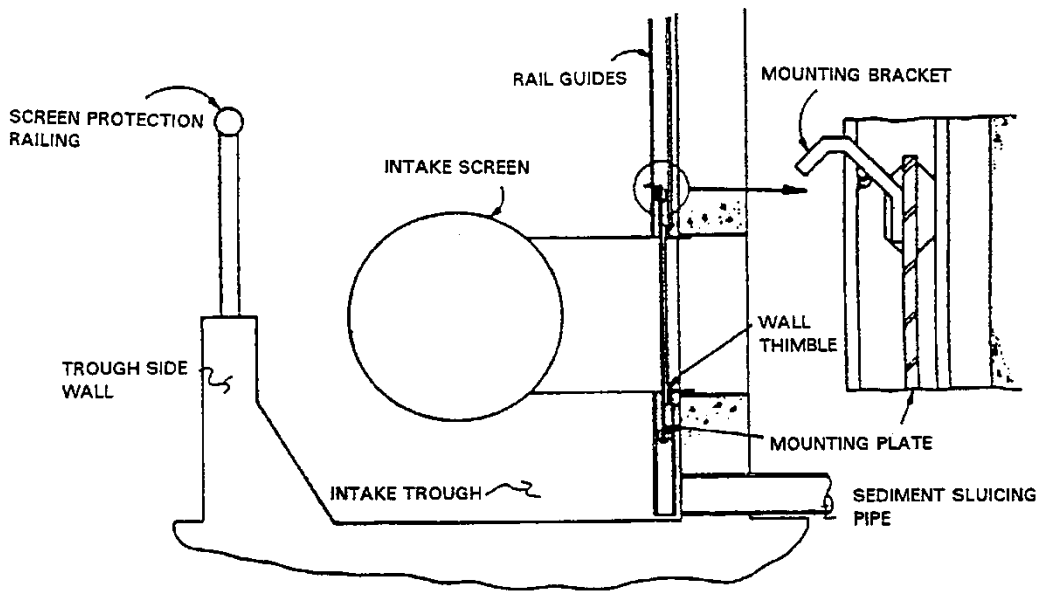
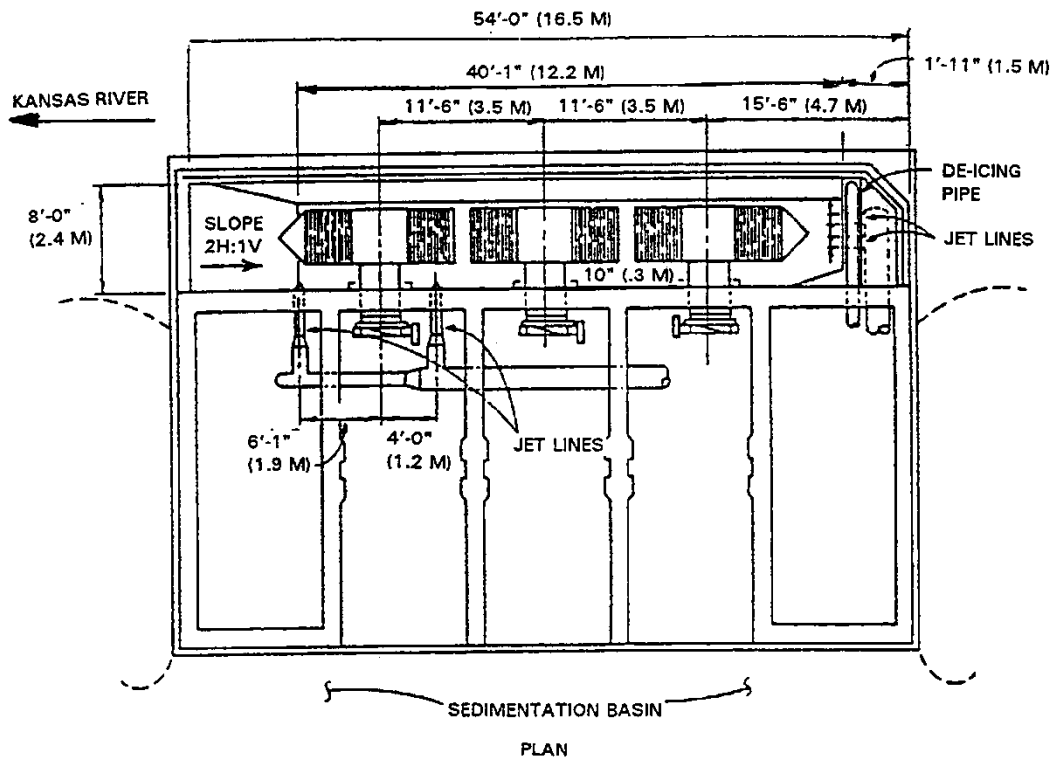
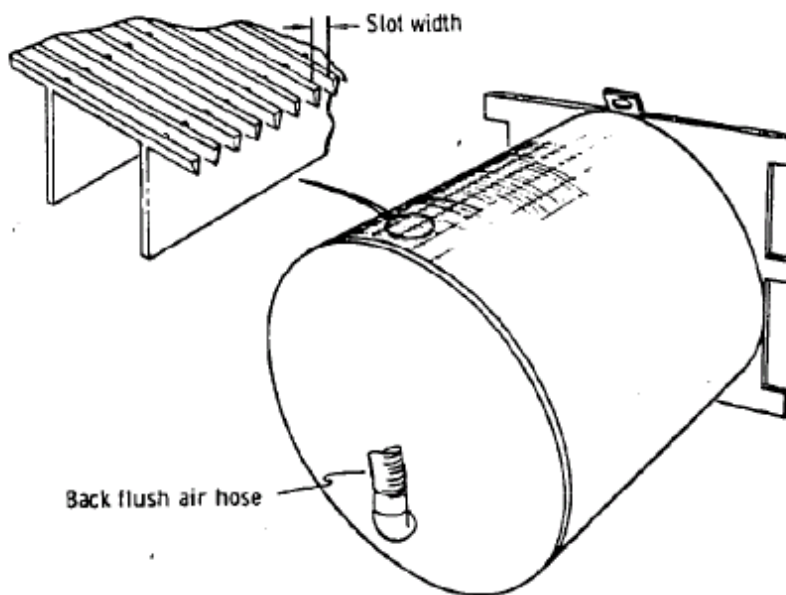


Figure 5-5  
Wedgewire screen intake system — Jeffrey Energy Center (Johnson and Ettema 1988)

### Chalk Point Station

A field evaluation of cylindrical wedgewire screens was conducted at the Chalk Point Station in Aquasco, Maryland from 1982 to 1983 (Weisberg et al. 1987). A modular barge testing facility

was placed in the intake canal of the station. The barge had two separate but identical intake ports on which 76-cm (30-in.) diameter cylindrical wedgewire test screens and an open port were attached (Figure 5-6). During testing in 1982, the pumps withdrew approximately 7.7 m<sup>3</sup>/min (4.5 cfs), while in 1983, after refurbishing, the pumps withdrew 12 m<sup>3</sup>/min (7.1 cfs). The intakes were positioned 1 m (3.3 ft) below the surface. Screens with slot sizes measuring 1, 2, and 3 mm (0.039, 0.079, and 0.12 in.) were evaluated. Average through slot velocities for all of the screens together in 1982 and 1983 were 13 cm/sec (0.43 ft/sec) and 20 cm/sec (0.66 ft/sec), respectively.



**Figure 5-6**  
**Drawing of a bulkhead-mounted screen with cut away of wedgewire configuration (Weisberg et al. 1987)**

Samples were collected at night using a 505- $\mu$ m mesh plankton net located at the discharge from each pump. A total of 24 samples was collected during testing in 1982 and 88 samples were collected in 1983. Ambient ichthyoplankton samples were collected just upstream from the testing barge by towing a bongo net measuring 0.5 m (1.64 ft) in diameter with a 505- $\mu$ m mesh at the surface and at depths of 1 and 2 m (3.3 and 6.6 ft).

The most abundant fish species collected were bay anchovy and naked goby. Bay anchovies (*Anchoa mitchilli*) were grouped by length classes of  $\leq 4$  mm, 5 to 7 mm, 8 to 10 mm, 11 to 14 mm, and  $\geq 15$  mm ( $\leq 0.16$  in., 0.20 to 0.28 in., 0.31 to 0.39 in., 0.43 to 0.55 in., and  $\geq 0.60$  in.). Naked gobies (*Gobiosoma bosc*) were grouped by length classes of  $\leq 4$  mm, 5 to 6 mm, 7 to 8 mm, and  $\geq 9$  mm ( $\leq 0.16$  in., 0.20 to 0.24 in., 0.28 to 0.31 in., and  $\geq 0.35$  in.) Numbers of fish entrained are presented in Table 5-1.

**Table 5-1**

Mean densities (numbers/1,000 m<sup>3</sup> of water) of bay anchovies and naked gobies collected in the bongo net from the canal, through each wedgewire exclusion screen, and through an open port in 1982 and 1983 (Weisberg et al. 1987).

| Fish Class Size (mm) | August 1982 |           |        |      | July 1983 |           |        |        |        |
|----------------------|-------------|-----------|--------|------|-----------|-----------|--------|--------|--------|
|                      | Bongo Net   | Open Port | Screen |      | Bongo Net | Open Port | Screen |        |        |
|                      |             |           | 2 mm   | 1 mm |           |           | 3 mm   | 2 mm   | 1 mm   |
| <b>Bay Anchovy</b>   |             |           |        |      |           |           |        |        |        |
| Eggs                 | 0.0         | 0.0       | 0.0    | 0.0  | 19,610    | 2,341     | 1,707  | 18,435 | 10,966 |
| ≤ 4                  | 2.0         | 0.0       | 0.0    | 0.0  | 60.0      | 9.6       | 13.6   | 21.0   | 9.2    |
| 5 – 7                | 4.5         | 4.1       | 0.0    | 0.0  | 37.6      | 20.1      | 11.3   | 9.2    | 10.8   |
| 8 - 10               | 6.2         | 1.6       | 1.5    | 0.0  | 11.2      | 7.7       | 2.6    | 1.6    | 1.0    |
| 11 - 14              | 152.9       | 31.1      | 10.5   | 0.0  | 3.5       | 1.3       | 0.3    | 0.0    | 0.0    |
| ≥ 15                 | 2,469.4     | 57.3      | 15.0   | 1.5  | 9.3       | 3.3       | 0.5    | 0.4    | 0.0    |
| <b>Naked Goby</b>    |             |           |        |      |           |           |        |        |        |
| ≤ 4                  | 95.3        | 17.2      | 13.5   | 1.5  | 223.5     | 535.7     | 557.1  | 513.4  | 562.5  |
| 5 – 6                | 117.6       | 22.9      | 19.5   | 6.0  | 514.8     | 148.7     | 87.6   | 81.6   | 66.5   |
| 7 – 8                | 95.5        | 38.5      | 16.5   | 5.8  | 370.5     | 49.7      | 11.2   | 9.6    | 3.9    |
| ≥ 9                  | 342.3       | 201.5     | 64.6   | 35.8 | 243.7     | 49.1      | 7.8    | 4.4    | 1.9    |

For bay anchovy, the screens had no significant effect (i.e., exclusion) on eggs and larvae measuring ≤ 4mm (≤ 0.16 in.). Exclusion became apparent at the 5 to 7-mm (0.2 to 0.28 in.) length class in 1983, as nearly twice as many anchovy were entrained into the unprotected open intake than into any of the screens. Exclusion increased with increasing fish length. Although more fish were entrained through the larger slot sizes, the differences were not significant, which may have been due to the small sample sizes.

Although there was over a tenfold decrease in entrainment of naked goby measuring ≤ 4mm (≤ 0.16 in.) between the unprotected and 1-mm (0.04-in.) screen in 1982, the difference was not statistically significant. Exclusion by the 1-mm (0.04-in.) screen became apparent at the 5 to 6 mm (0.2 to 0.24 in.) length in 1983. Further, both years of sampling yielded a significant decrease in the entrainment of fish measuring 7 to 8 mm (0.28 to 0.31 in.) and larger.

The authors cite physical exclusion and hydrodynamic exclusion as the two principal modes by which wedgewire screens protect ichthyoplankton from entrainment. Evidence for the physical exclusion caused by the screens is that the smallest slot size (1 mm [0.04 in.]) excluded more fish than either the 2 or 3-mm (0.08 or 0.12-in.) screens. Further evidence of physical exclusion is that a head capsule depth of 1 mm (0.04 in.) was not reached until a length of 9 mm (0.35 in.), and there were essentially no fish over 10 mm (0.39 in.) entrained in the samples. Evidence for the hydrodynamic exclusion is that fish of both species measuring 5 mm (0.2 in.) in length were not entrained by the 3-mm (0.12-in.) screen, indicating their ability to swim away from the low-velocity flow near the screen.

### **Charles Point Recovery Facility**

Environmental monitoring studies were conducted at the Charles Point Resource Recovery Facility to evaluate the number, species, and life stage of organisms impinged and entrained by the facility's cooling water system (EA Science and Technology 1986). This wedgewire screen facility has been operating since the early 1980s with little maintenance required (Radle pers. comm. 1999). The biological studies were performed as a requirement of Westchester RESCO's SPDES permit. The facility is located on the east bank of the Hudson River near Peekskill, New York.

The Charles Point Resource Recovery Facility has a design capacity of 60 MW generated by the combustion of municipal solid waste. The once-through cooling system has a flow rate of 2.4 m<sup>3</sup>/sec (85 cfs). The cooling water system consists of an offshore (243.8 m [800 ft]) intake fitted with four pairs of cylindrical wedgewire screens mounted on T-stands approximately 1.5 m (5 ft) above the river bottom. The cylindrical wedgewire screens are 1.4 m (4.6 ft) long, 1.4 m (4.6 ft) in diameter, and constructed of a copper-nickel alloy. The slot width of the screens is 2.0 mm (0.08 in.), resulting in a design through-slot velocity of 0.15 m/sec (0.5 ft/sec).

The monitoring study was designed to sample ichthyoplankton entrainment and impingement. Entrainment monitoring was conducted using an Automated Abundance Sampler (AUTOSAM). Six samples were collected on each date for a 4-hour duration at approximately 1% of the total flow. A combined total of 15,287 ichthyoplankton was collected by the AUTOSAM from May through October in 1985 and March through April in 1986. The most abundant species collected during entrainment sampling from mid-June through September 1985 was bay anchovy (*Anchoa mitchilli*) (93.5%). Other ichthyoplankton collected were striped bass (*Morone saxatilis*) (4.2%), white perch (*Morone americana*) (0.9%), and Atlantic tomcod (*Microgadus tomcod*) (0.7%). The most abundant lifestages collected in entrainment samples were eggs (67.3%) and post-yolk-sac larvae (31.2%).

Impingement sampling was conducted from May 1985 through April 1986. Organisms were removed from the intake screens by a specially designed apparatus. A series of guide bars were welded lengthwise across each of the screen intake structures to allow a vacuum head to move over the screens and remove impinged organisms. The vacuum head was operated by a diver and attached to a pump that transported impinged organisms into a collection facility. Vacuumed materials were screened through a 500- $\mu$ m mesh net in order to separate impinged organisms from those that had already passed through the wedgewire screens (Radle pers. comm. 1999).

A total of 175 organisms were collected during 37 samples. Bay anchovy was the most abundant species (70.3%) collected. Atlantic tomcod, striped bass, and white perch comprised 25.7, 1.1, and 0.6% of the total impingements collected, respectively. Similar to entrainment samples, eggs were the most abundant life stage (61.1%) collected during impingement sampling, followed by larvae (37.1%).

### **Oyster Creek Nuclear Generating Station**

A field study was conducted in 1978 to assess the engineering and biological performance of cylindrical wedgewire screens (Browne 1979) at the Oyster Creek Nuclear Generation Station. The test screens were mounted on a floating test facility that was moored in the intake canal of

the station. The test facility had two 7.6 m<sup>3</sup>/min (2,000-gpm) vertical pumps. Screens with slot widths of 1, 2, and 3 mm (0.04, 0.08, and 0.12 in.) were tested. The screens measured 76.2 cm (30 in.) in diameter, were set at a depth of 1 m (3.3 ft), and were designed to generate an average through slot velocity of 15.2 cm/sec (0.5 ft/sec) during their evaluation. The screens were also outfitted with air backflushing mechanisms that would activate when a set pressure differential occurred across the screen face. If backwashing did not maintain a differential of less than 40.6 cm (16 in.), the screens were raised to the test facility's deck for high-pressure spray washing.

Results of the engineering evaluation revealed that, despite high debris loads during the spring and early summer, all the screens functioned well with respect to the removal of debris by air backflushing. Overall down time associated with cleaning the screens was 0.02 to 1.30% and 0.29 to 1.40% for the 1- and 2-mm (0.04- and 0.8-in.) screens, respectively. The author suggested that these estimates would be decreased substantially by the addition of an automatic cleaning system.

The biological evaluation of the test screens included entrainment and impingement sampling. Entrainment samples were collected from the pump discharge pipes using 0.5-m (1.6-ft) diameter plankton nets with 500- $\mu$ m mesh. Impingement of larger organisms and fish behavior near the screens was monitored concurrently to entrainment sampling.

Organisms were not entrained in large enough numbers to draw any significant conclusions. However, the data that was collected did indicate that fewer target species were entrained through the 1-mm (0.04-in.) slot screen than through the 2-mm (0.08-in.) screen and an unscreened intake. Also, target species entrained through the 1-mm (0.04-in.) screen were generally smaller and narrower than those entrained through the 2-mm (0.08-in.) screen and the unscreened intake, and densities of target species entrained through the 2-mm (0.08-in.) screen were sometimes equal to and occasionally greater than densities entrained through the unscreened intake. Entrainment data for opossum shrimp are presented in Table 5-2.

Monitoring of the screens in situ (Browne et al. 1981) revealed that impingement was negligible for organisms near the screens. However, American eel (*Anguilla rostrata*) elvers were observed impinged on the screens or entrapped in the slots during observations made from January to April. Various invertebrates were also found impinged on the screen face, though many crabs, amphipods, and isopods were also seen moving freely along the screen face, possibly feeding on the other impinged organisms. Larval fish (20 to 25 cm [7.9 to 9.8 in.] TL), such as silversides (Atherinidae), were also seen swimming near the screen in ambient currents of 15 to 20 cm/sec (0.5 to 0.7 ft/sec) without any signs of difficulty. Further, impingement of adult fish did not appear to be an issue.

Besides blue crab, there were no significant differences in entrainment densities of fish and invertebrates in the 1- and 2-mm (0.04- and 0.08-in.) screens during in situ monitoring. Organisms entrained in the 1-mm (0.04-in.) screen were typically smaller than organisms entrained by the 2-mm (0.08-in.) screen and unscreened intake. In some cases, entrainment densities were not significantly different between the 1- and 2-mm (0.04- and 0.08-in.) screen and the open intake. The authors suggest that this may be caused by a negative rheotrophic response to the nearfield velocity regime adjacent to the intake orifice. Entrainment data are presented in in Table 5-3.

The amount of biofouling on different screen material revealed that, of the four samples tested, the steel containing the highest amount of copper possessed the best antifouling characteristics.

**Table 5-2**

**Density (no./m<sup>3</sup>) length (mm), and width (mm) of Mysidacea (opossum shrimp) in entrainment sample sets collected January 3, 1979 (Browne 1979).**

|                                           | 1-mm Screen | 2-mm Screen | No screen (control) |
|-------------------------------------------|-------------|-------------|---------------------|
| <b>Sample Set 1</b>                       |             |             |                     |
| Density (No./m <sup>3</sup> )             | 8.9         | 22.4        | 19.3                |
| Density relative to no screen density (%) | 46.0        | 116.0       | 100.0               |
| Length range (mm)                         | 3.2–7.8     | 3.3–9.7     | 3.8–10.1            |
| Mean length (mm)                          | 5.0         | 6.0         | 5.7                 |
| Width range (mm)                          | 0.4–0.8     | 0.4–1.1     | 0.4–1.2             |
| Mean width (mm)                           | 0.6         | 0.7         | 0.7                 |
| <b>Sample Set 2</b>                       |             |             |                     |
| Density (No./m <sup>3</sup> )             | 16.2        | 26.6        | 20.0                |
| Density relative to no screen density (%) | 81.0        | 133.0       | 100.0               |
| Length range (mm)                         | 3.0–9.3     | 3.3–10.6    | 3.5–8.7             |
| Mean length (mm)                          | 5.2         | 5.6         | 5.2                 |
| Width range (mm)                          | 0.3–1.1     | 0.4–1.2     | 0.4–1.0             |
| Mean width (mm)                           | 0.6         | 0.6         | 0.6                 |



**Table 5-3**  
**Density (no./m<sup>3</sup>) length (mm), and width (mm) of Mysidacea (opossum shrimp) in entrainment sample sets collected January 3, 1979 (Browne 1981).**

| <b>Taxon</b>       | <b>Lifestage</b> | <b>Gear Type</b> | <b>Mean Density<br/>(n/ 100 m<sup>3</sup>)</b> |
|--------------------|------------------|------------------|------------------------------------------------|
| bay anchovy        | Egg              | 1 mm Screen      | 128                                            |
|                    |                  | 2 mm Screen      | 135                                            |
|                    |                  | Intake Orifice   | 182                                            |
|                    |                  | Bongo Net        | 724                                            |
| bay anchovy        | Larvae           | 1 mm Screen      | 12                                             |
|                    |                  | 2 mm Screen      | 17                                             |
|                    |                  | Intake Orifice   | 31                                             |
|                    |                  | Bongo Net        | 34                                             |
| family atherinidae | Larvae           | 1 mm Screen      | 20                                             |
|                    |                  | 2 mm Screen      | 26                                             |
|                    |                  | Intake Orifice   | 10                                             |
|                    |                  | Bongo Net        | 54                                             |
| sygnathus fucus    | Larvae           | 1 mm Screen      | 7                                              |
|                    |                  | 2 mm Screen      | 11                                             |
|                    |                  | Intake Orifice   | 25                                             |
|                    |                  | Bongo Net        | 44                                             |
| family blennidae   | Larvae           | 1 mm Screen      | 8                                              |
|                    |                  | 2 mm Screen      | 6                                              |
|                    |                  | Intake Orifice   | 9                                              |
|                    |                  | Bongo Net        | 17                                             |
| family gobiidae    | Larvae           | 1 mm Screen      | 15                                             |
|                    |                  | 2 mm Screen      | 31                                             |
|                    |                  | Intake Orifice   | 13                                             |
|                    |                  | Bongo Net        | 96                                             |

**Table 5-3 (Continued)**

| <b>Taxon</b>        | <b>Lifestage</b> | <b>Gear Type</b> | <b>Mean Density<br/>(n/ 100 m<sup>3</sup>)</b> |
|---------------------|------------------|------------------|------------------------------------------------|
| order polychaeta    | Larvae           | 1 mm Screen      | 33                                             |
|                     |                  | 2 mm Screen      | 36                                             |
|                     |                  | Intake Orifice   | 22                                             |
|                     |                  | Bongo Net        | 100                                            |
| order cumacea       | Adults           | 1 mm Screen      | 221                                            |
|                     |                  | 2 mm Screen      | 116                                            |
|                     |                  | Intake Orifice   | 125                                            |
|                     |                  | Bongo Net        | 1,059                                          |
| family mysidae      | Adults           | 1 mm Screen      | 42                                             |
|                     |                  | 2 mm Screen      | 57                                             |
|                     |                  | Intake Orifice   | 56                                             |
|                     |                  | Bongo Net        | 42,277                                         |
| cragon setemspinosa | Zoeae            | 1 mm Screen      | 125                                            |
|                     |                  | 2 mm Screen      | 116                                            |
|                     |                  | Intake Orifice   | 90                                             |
|                     |                  | Bongo Net        | --                                             |
| callinectes sapidus | Megalopae        | 1 mm Screen      | 3                                              |
|                     |                  | 2 mm Screen      | 12                                             |
|                     |                  | Intake Orifice   | 9                                              |
|                     |                  | Bongo Net        | --                                             |
| order amphipoda     | Adults           | 1 mm Screen      | 229                                            |
|                     |                  | 2 mm Screen      | 210                                            |
|                     |                  | Intake Orifice   | 213                                            |
|                     |                  | Bongo Net        | 353                                            |

***St. John's River, FL***

A study similar to those conducted by Browne (1979) was conducted by Lifton (1979) on the St. John's River in northeastern Florida. The investigations were conducted as a requirement of Section 316(b) during the construction of a coal-fired electric generating station in Putnam County, Florida. In this study, entrainment through 1- and 2-mm (0.04- and 0.08-in.) slot wedgewire screens were compared to entrainment through an open pipe and concurrent plankton

tows. Entrainment collections were made from March through September for a total of 134 samples. The study was conducted in three phases. Phase I involved in-river sampling to identify species and life stages vulnerable to entrainment. Phase II involved the collection of data on the exclusion differences between 1- and 2-mm (0.04- and 0.08-in.) screens, and Phase III examined operational feasibility, biofouling, and entrainment mitigation.

Individual egg and larvae fish collections for Phase I were conducted by net tow sampling using a 363- $\mu\text{m}$  mesh plankton net. The wedgewire screen test facility used in Phase II and Phase III was located on an existing dock at the power plant site. Sampling was conducted over an 8-day period, and included visual observations of the wedgewire screens, in-river larval tows, and open pipe entrainment tests to provide control data.

The majority of fish entrained through the 1 and 2-mm (0.04- and 0.08-in.) screens were unidentified Atherinidae (silverside) species, tidewater silversides (*Menidia peninsulae*), naked goby (*Gobiosoma boscii*) and clown goby (*Gobiodon okinawae*). The predominant species entrained through the open pipe were bay anchovy (*Anchoa mitchilli*), tidewater silverside, sunfish (*Lepomis macrochirus*), naked goby, and clown goby. Fish eggs and larvae were collected in the 1-mm (0.04-in.) screen samples. The 2-mm (0.08-in.) screen also entrained two juveniles and some adult fish were entrained through the open pipe. Results of statistical analyses showed no significant difference in entrainment between the 1- and 2-mm (0.04- and 0.08-in.) screen with respect to organism densities for all species and life stages. Comparisons of total numbers entrained showed that the screened intakes entrained at least 30% fewer fish than the open pipe in 16 of 20 comparisons. In 13 of 20 comparisons, the number of fish entrained was at least 50% less than the open pipe.

### **J. H. Campbell, Unit 3**

Consumers Energy's J. H. Campbell Unit 3 screen system has functioned effectively since 1979. Unit 3 withdraws 24 m<sup>3</sup>/s (849 cfs) from an offshore location (1,067 m [3,500 ft] from shore in 10.7 m [35 ft] of water) through 28 fixed wedgewire screening units with 9.5-mm (3/8-in.) wide screen slots with a through slot velocity of 0.15 m/sec (0.5 ft/sec). Units 1 and 2 withdraw cooling water from Pigeon Lake, which empties into Lake Michigan adjacent to the station. It was believed that locating the Unit 3 intake in the relatively unproductive lake environment would decrease the potential for entrainment and impingement. When compared to Units 1 and 2, the Unit 3 screens have reduced impingement of gizzard shad (*Dorosoma cepedianum*), rainbow smelt (*Osmerus mordax*), yellow perch (*Perca flavescens*), alewife (*Alosa pseudoharengus*), and shiner (Cyprinidae) species and have required minimal maintenance (Gulvas and Zeitoun 1979). The screens are cleaned manually by water jets to reduce biofouling (algae). The plant was forced to shut down once (spring 1984) due to anchor ice. Because the screen mesh is 9.5 mm (3/8 in.), this installation achieves no reduction in entrainment other than by virtue of its deep offshore location in an area of low abundance of entrainable-sized fish. Concurrent studies (Roarabaugh et al. 1979 & Zeitoun et al. 1981) concluded that there were no significant differences in entrainment densities between 2.0- and 9.5-mm (0.08- and 0.37-in.) screens and the open pipe because of low abundance of entrainable size fish. Operating experience to date has been satisfactory, due to the large screen slot size and the relatively low debris loading in Lake Michigan.

## **Case Studies – Hydroelectric Application**

### ***Arbuckle Mountain Hydroelectric Project***

A cylindrical wedgewire screen system was installed in 1986 at the Arbuckle Mountain Hydroelectric Project located on the Middle Fork of Cottonwood Creek near Redding, California (Ott et al. 1988). The project operates in a run-of-the-river mode, diverts a maximum of 3.3 m<sup>3</sup>/sec (115 cfs), has a design head of 16.8 m (55 ft), and a generating capacity of about 400 kW. Cylindrical wedgewire screens were selected for Arbuckle Mountain to prevent entrainment of resident and migratory fish and to provide for continuous cleaning to eliminate sediment and debris buildup. Also, a vertical-axis configuration was selected because material and construction costs were less than for a horizontal deployment.

The final design of the screen system installed at Arbuckle Mountain consisted of eight screens, with an intake flow of 0.4 m<sup>3</sup>/sec (15.7 cfs) per screen. At maximum capacity, the approach velocity component (normal to the screen face) is 0.1 m/sec (0.33 ft/sec). The screen V-wire was 1.8 mm (0.071 in.) wide with slot openings 2.4 mm (0.094 in.), yielding an open area of 57%. The screens are mounted on a concrete manifold/plenum chamber and placed in the project forebay. An internal flow modulator was designed to create uniform flow distribution across the face of the screen cylinders. For debris management, a pneumatically operated programmable controller was developed to automatically initiate cleaning of the eight cylindrical screens with an air burst backwash system. An annular air distributor is mounted outside the flow modulator that introduces air within a cylinder to backflush water for removal of any debris collected on the exterior of the cylinder. Also, a conical deflector mounted internally at the top of each cylinder provides even distribution of the air burst during the backflush cycle. After backflushing, ambient currents remove accumulated debris. Biological evaluations of the screen system have not been performed.

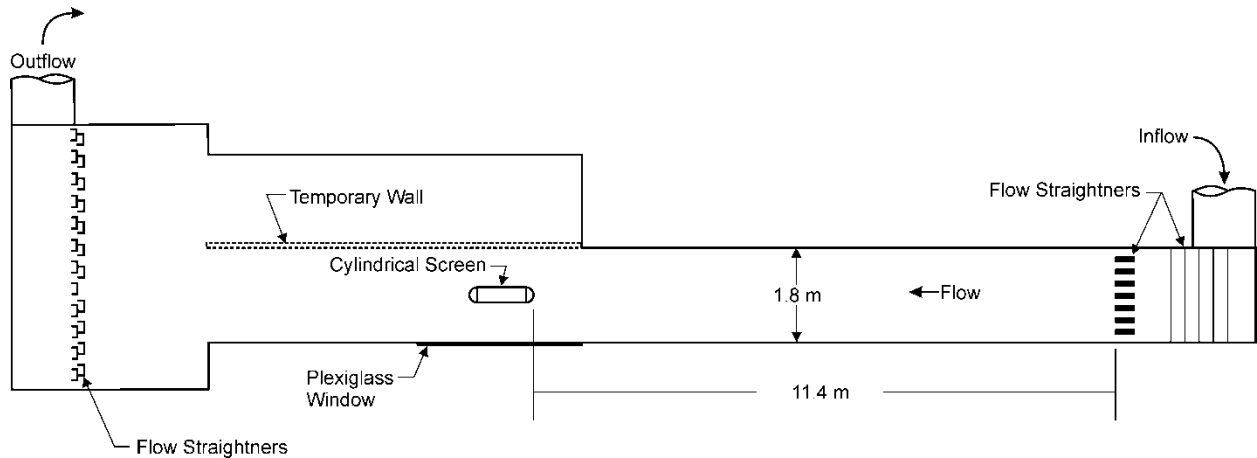
## **Case Studies – Laboratory and Field Evaluations**

### ***Laboratory Test EPRI/EPA, Alden Research Laboratory***

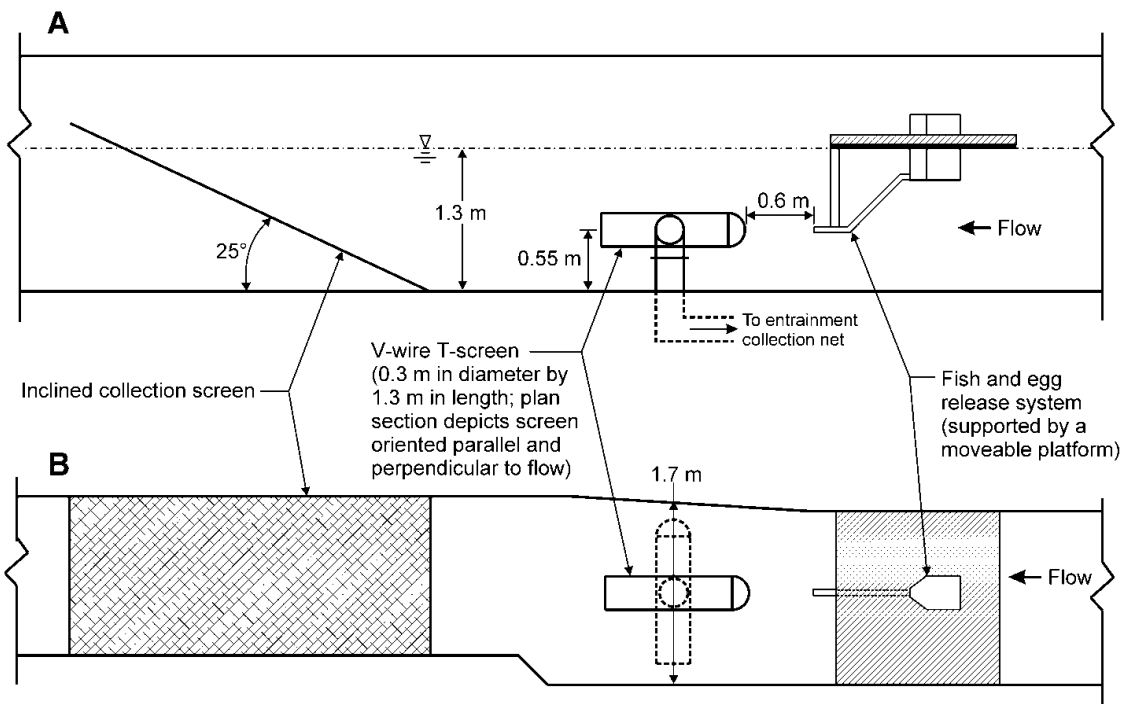
The Electric Power Research Institute (EPRI) with Water Quality Cooperative Grant (#X829108010) support from the U.S. Environmental Protection Agency (EPA) sponsored the biological evaluation of cylindrical wedgewire screens (EPRI 2003). The testing was conducted in a laboratory flume with striped bass larvae (*Morone saxatilis*) and a surrogate egg type in 2001 and with eight species in 2002. The tests conducted in 2001 were primarily designed to determine if the test facility and procedures functioned as needed for accurately evaluating the relative effectiveness of the wedgewire screens. These tests also provided the initial set of data on relative impingement and entrainment rates of the organisms that were evaluated.

The section of the test facility flume where testing is performed has a maximum depth and width of 2.1 and 3.0 m (7 and 10 ft), respectively. For 2001 testing, the width of the flume channel was about 1.5 m (5 ft) and water depth was 1.3 m (4.25 ft). Flume width and water depth for 2002 tests were both 1.8 m (6 ft) (a temporary wall was removed and the plexiglass window was repositioned to widen the flume prior to 2002 testing). Channel velocities up to 0.9 m/sec (3 ft/sec) can be maintained at full depth. Flow is re-circulated through the flume by a bow thruster that is driven by an electric motor.

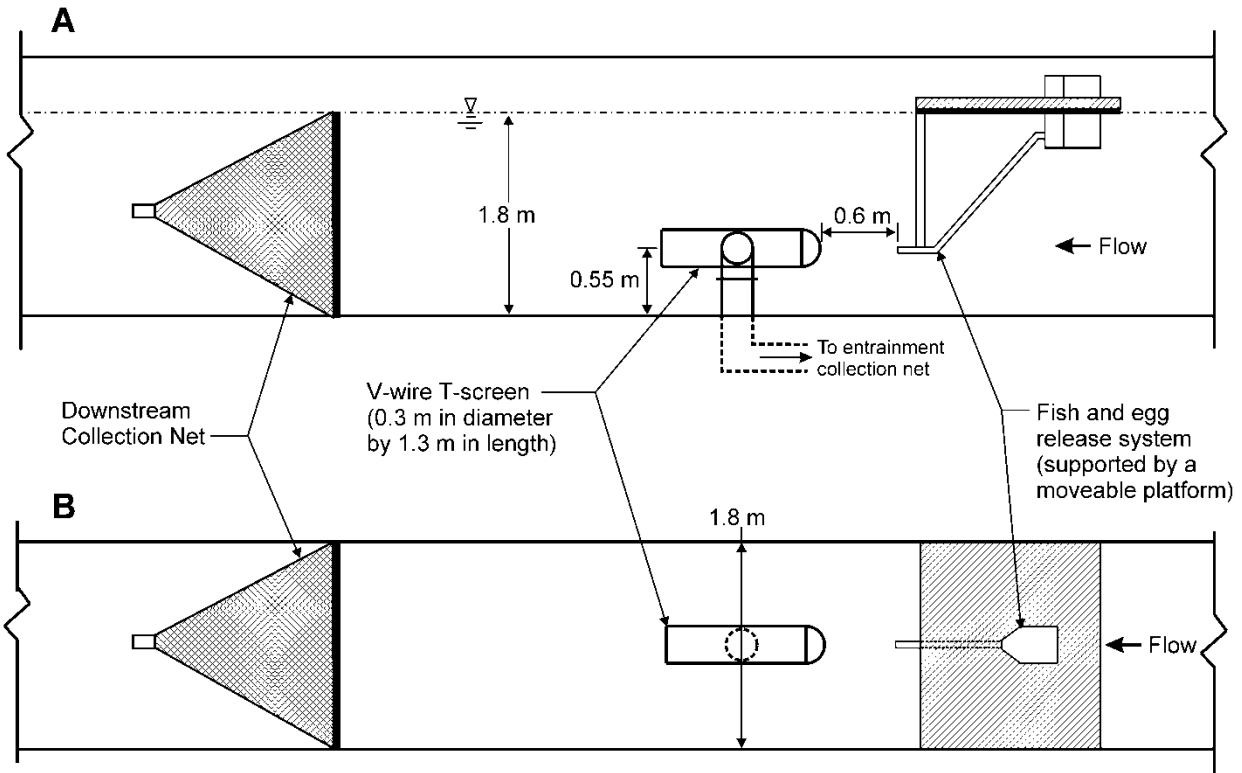
The location of the screens was about 11.4 m (37.5 ft) downstream of where water is returned to the flume from the bow thruster (Figure 5-7). At this location, one side of the flume consists of a plexiglass window that allows for real-time visual and video observations to be recorded during testing. The wedgewire screen test facility consists of a fish larvae and egg release system, the wedgewire screens, an entrainment collection system, and a downstream collection system. The design of the test facilities used in 2001 and 2002 are presented in Figure 5-8 and Figure 5-9, respectively.



**Figure 5-7**  
Fish testing facility and approximate location of cylindrical wedgewire screens (EPRI 2003)

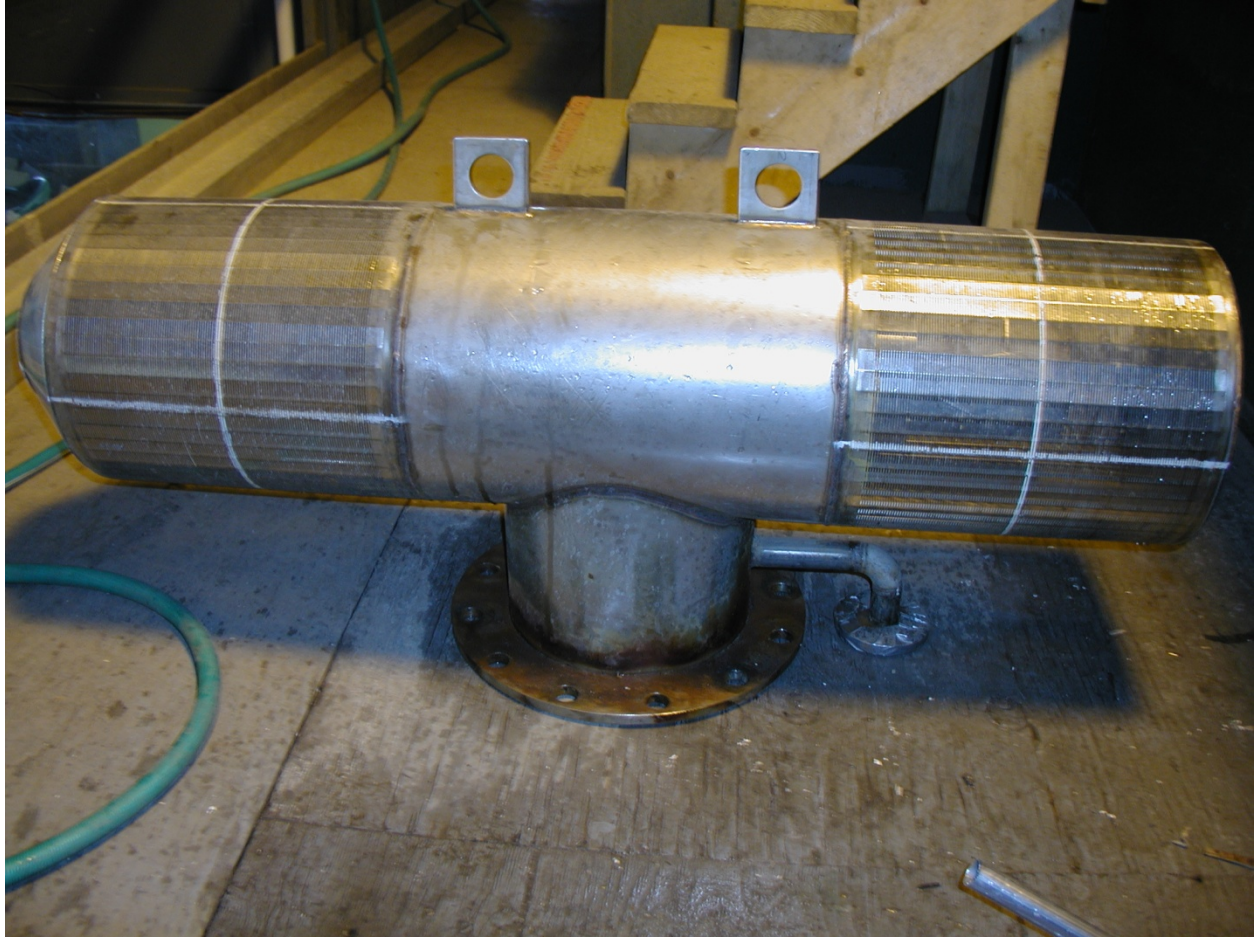


**Figure 5-8**  
2001 wedgewire screen test facility (EPRI 2003)



**Figure 5-9**  
**2002 wedgewire screen test facility (EPRI 2003)**

The screens that were used for the laboratory evaluation were T-12 (30.5-cm diameter [12-in.]) cylindrical wedgewire screens supplied by Johnson Screen (Figure 5-10). The T-12 screens have two 31 cm (1 ft) long sections through which water is withdrawn. Three screens constructed with different slot sizes (0.5, 1.0, and 2.0 mm [0.02, 0.04, and 0.08 in.]) were evaluated to determine fish egg and larval entrainment and impingement rates under different channel and screen flow conditions. All three screens had 1.5 mm (0.06 in.) wide wedgewire bars. The porosities of the screens were 24.7% for the 0.5-mm (0.02-in.) slot screen, 39.6% for the 1.0-mm (0.04-in.) screen, and 56.8% for the 2.0-mm (0.04-in.) screen. Design information and flow rates at each through-slot velocity that was evaluated are presented in Table 5-4.



**Figure 5-10**  
**Johnson T-12 cylindrical wedgewire screen (white lines delineate sections of the screen for which impingement locations were recorded) (EPRI 2003)**

**Table 5-4**  
**Wedgewire screen design and operation parameters evaluated during the laboratory study (EPRI 2003)**

| Slot size (mm) | Screen Open Area (m <sup>2</sup> ) | Screen Porosity (%) | Slot Velocity (m/sec) | Screen Withdrawal Rate |       | Channel Velocity (m/sec) | Channel Flow Rate   |       |                     |        |
|----------------|------------------------------------|---------------------|-----------------------|------------------------|-------|--------------------------|---------------------|-------|---------------------|--------|
|                |                                    |                     |                       |                        |       |                          | 2001                |       | 2002                |        |
|                |                                    |                     |                       | m <sup>3</sup> /sec    | gpm   |                          | m <sup>3</sup> /sec | gpm   | m <sup>3</sup> /sec | gpm    |
| 0.5            | 0.15                               | 24.7                | 0.15                  | 0.023                  | 363   | 0.08                     | 0.15                | 2,376 | 0.26                | 4,039  |
|                |                                    |                     |                       |                        |       | 0.15                     | 0.30                | 4,753 | 0.51                | 8,078  |
|                |                                    |                     |                       |                        |       | 0.30                     | 0.60                | 9,506 | 1.02                | 16,157 |
|                |                                    |                     | 0.30                  | 0.046                  | 726   | 0.08                     | 0.15                | 2,376 | 0.26                | 4,039  |
|                |                                    |                     |                       |                        |       | 0.15                     | 0.30                | 4,753 | 0.51                | 8,078  |
|                |                                    |                     |                       |                        |       | 0.30                     | 0.60                | 9,506 | 1.02                | 16,157 |
| 1.0            | 0.24                               | 39.6                | 0.15                  | 0.037                  | 582   | 0.08                     | 0.15                | 2,376 | 0.26                | 4,039  |
|                |                                    |                     |                       |                        |       | 0.15                     | 0.30                | 4,753 | 0.51                | 8,078  |
|                |                                    |                     |                       |                        |       | 0.30                     | 0.60                | 9,506 | 1.02                | 16,157 |
|                |                                    |                     | 0.30                  | 0.073                  | 1,164 | 0.08                     | 0.15                | 2,376 | 0.26                | 4,039  |
|                |                                    |                     |                       |                        |       | 0.15                     | 0.30                | 4,753 | 0.51                | 8,078  |
|                |                                    |                     |                       |                        |       | 0.30                     | 0.60                | 9,506 | 1.02                | 16,157 |
| 2.0            | 0.35                               | 56.8                | 0.15                  | 0.053                  | 834   | 0.08                     | 0.15                | 2,376 | 0.26                | 4,039  |
|                |                                    |                     |                       |                        |       | 0.15                     | 0.30                | 4,753 | 0.51                | 8,078  |
|                |                                    |                     |                       |                        |       | 0.30                     | 0.60                | 9,506 | 1.02                | 16,157 |
|                |                                    |                     | 0.30                  | 0.105                  | 1,667 | 0.08                     | 0.15                | 2,376 | 0.26                | 4,039  |
|                |                                    |                     |                       |                        |       | 0.15                     | 0.30                | 4,753 | 0.51                | 8,078  |
|                |                                    |                     |                       |                        |       | 0.30                     | 0.60                | 9,506 | 1.02                | 16,157 |

The biological evaluation of cylindrical wedgewire screens successfully identified several important relationships associated with the various factors that affect impingement and entrainment of aquatic organisms. However, these relationships were not always straightforward or easily detectable due to interactions among the test variables and the inability to collect data for all species and life stages with all combinations of test conditions. The following are general conclusions from the analysis of the entrainment and impingement data that were collected:

1. Impingement decreased with increases in slot size
2. Entrainment increased with increases in slot size
3. Entrainment and impingement increased with increases in through-slot velocities
4. Entrainment and impingement decrease with increases in channel velocity



This study identified several biological factors that can influence wedgewire screen impingement and entrainment rates, including life stage, size, and swimming ability. These factors appeared to be strongly related; although for larvae, life stage is probably inconsequential compared to size and swimming ability. Specifically, as fish mature during early life stages, they grow larger and swimming ability improves, allowing for greater physical and behavioral exclusion to occur. The most pronounced effect of life stage is associated with differences between passive eggs and actively swimming larvae. The entrainment and impingement of eggs during this study were related to the size of eggs and hydraulic conditions that influenced downstream movement of eggs along the screen surface. Alewife (*Alosa pseudoharengus*) eggs, which averaged 0.7 mm (0.028 in.) in diameter, did not impinge on the 0.5-mm (0.02-in.) slot screen but were entrained at rates of 10 to 20% for the two channel velocities evaluated. The entrainment rate at the lower channel velocity was nearly 50% greater than at the higher velocity. In contrast to alewife, white sucker (*Catostomus commersonii*) and surrogate striped bass eggs were not entrained but were susceptible to impingement depending on the hydraulic conditions being evaluated. For both these species, egg impingement rates increased with slot velocity and decreased with channel velocity.

Based on the estimates of entrainment and impingement for larvae and eggs, protection of aquatic organisms using cylindrical wedgewire screens will be optimized by minimizing slot size and slot velocity and maximizing ambient currents approaching a screen or screen array. Design and operation criteria that result in optimization of these parameters will be dependent on the target species and life stages. Older and larger organisms will not require as stringent criteria as younger and smaller organisms that do not possess the size or swimming ability to avoid impingement and entrainment. Using less than optimum slot size and velocity criteria may be appropriate if wedgewire screens are located where species and life stages that are potentially susceptible to entrainment and impingement are not abundant.

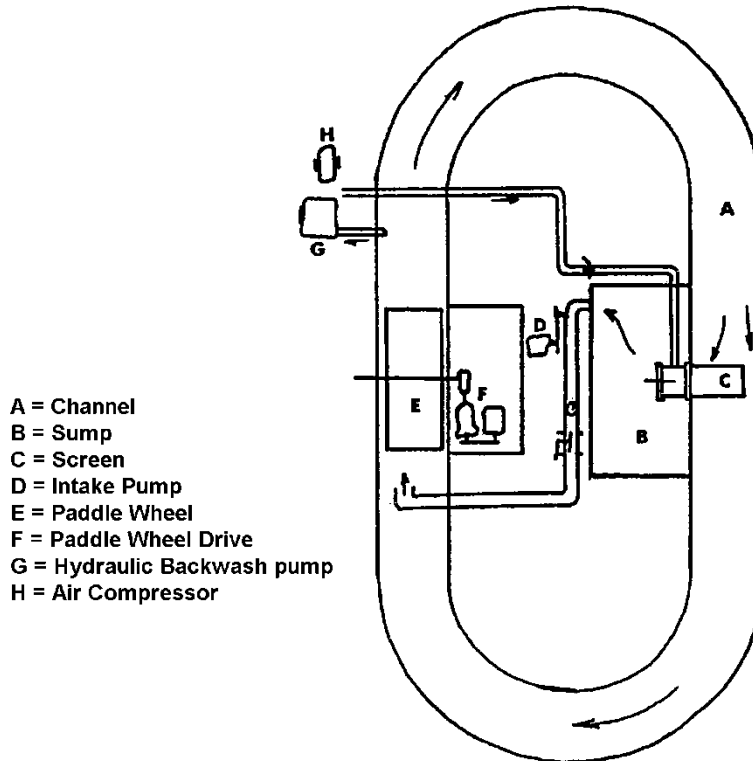
The data that was gathered during the biological components of this study clearly demonstrate that this technology can effectively protect early life stages of fish from entrainment and impingement when designed according to appropriate biological and hydraulic criteria. It was concluded that future studies, whether conducted in the laboratory or field, should focus on interrelationships among a smaller set of design criteria or for specific species and life stages. Such studies are expected to provide more specific descriptions and a better understanding of the relationships between biological and engineering design parameters that maximize fish protection effectiveness.

### **Laboratory Evaluation – Delmarva Power and Light**

Laboratory studies were conducted by Delmarva Power and Light to assist in the development of a surface water intake using wedgewire screens that would be effective in protecting the early life stages of fishes (Hanson et al. 1977). These studies were initially conducted to determine the entrainment and impingement of striped bass (*Morone saxatilis*) eggs, larvae, and juveniles but were later expanded to include other fish species. Additional studies were also performed to investigate potential egg mortality associated with screen contact and impingement.

The majority of the experiments were carried out in a 9.1 by 4.6 m (30 by 15 ft) oval flume (Figure 5-11). The flume was constructed of aluminum and plywood and was 0.84 m (2.75 ft) wide and 1.22 m (4 ft) deep. The test screens were placed in the flume and were evaluated under

both static (no flume flow) and dynamic (flume flow past the screens) conditions. A 5 hp horizontal pump was used to withdraw flow through the screens with a maximum pump rate of 0.03 m<sup>3</sup>/sec (1.13 cfs).



**Figure 5-11**  
**Schematic diagram of wedgewire test flume (Hanson et al. 1977)**

Egg mortality studies were conducted with a flat 30.5-cm (12-in.) square screen panel with a 0.5-mm (0.02-in.) slot width. The panel screen was placed on the flume wall orientated perpendicular to the flow. The test screens used to evaluate the exclusion of striped bass eggs, larvae, and juveniles had slot widths of 1 mm (0.04 in.) or less. Tests with larval striped bass employed cylindrical wedgewire screens with a diameter of 30.5 cm (12 in.) and a length of 61 cm (24 in.). The cylindrical screens were placed horizontally across the flume channel at about mid-depth (Figure 5-11).

Striped bass eggs used in the mortality studies were obtained from an onsite hatchery. The experiments consisted of 30-, 60-, and 120-second impingement trials using live eggs. Trials had one replicate and one control for each duration. The number of dead eggs was counted and recorded every 30 min. Egg impingement trials were conducted by releasing a known number of live eggs into a 0.15 m/sec (0.5 ft/sec) current approximately 1.2 m (4 ft) upstream of the test screen panel. After the eggs had been impinged for the specified duration, they were siphoned off the screen into a jar and observed for mortality at 5, 20, 45, and 60 min for the first two tests and at 5, 30, and 60 min for the remaining tests. A total of 6,945 striped bass eggs were used in 26 tests. The eggs ranged in developmental stage from gastrula to fully developed embryo.

Statistical tests revealed significant differences between control and test mortality at the 30-min impingement observations. The gastrula and early embryo developmental stages suffered higher mortality than other stages in both test and control specimens. Mortality resulting from impingement ranged from none to 11.9%. Overall, mean mortality from impingement was 1.4%. Most mortality occurred within the first 30 min of impingement.

Experiments were performed to determine swimming ability and avoidance behavior of striped bass larvae exposed to a wedgewire screen in static mode (i.e., all flow withdrawn through test screen with no channel cross-flow). Groups of 50 or less larvae were introduced into the flume and allowed to acclimate for up to 3 hrs. The specimens were then released into the test area, which was formed by the screen and a cage that kept them in close proximity to the screen. For each test, a velocity of 0.04 to 0.15 m/sec (0.13 to 0.50 ft/sec) was established through the test screen and subsequent behavior of test organisms was noted. The tests were run until all of the larvae were entrained, which generally occurred in less than 5 min. The larvae were recovered from the screen discharge pipe in a 500  $\mu$ m mesh net. Condition and length of the recovered specimens was then recorded and the surviving larvae were held separately for later experiments.

More than 1,000 larval striped bass were used in 42 tests. Swimming performance and ability to avoid entrainment was rated on an individual and group basis. Avoidance behavior was displayed in all the experimental trials. Many specimens exhibited resistance even when contact was made with the screen. Specimens that did not contact the screen were entrained more passively.

Larger fish were acquired in seine collections from nearby sources. Some striped bass were also supplied by the onsite hatchery. The larger test specimens were given 4 to 16 hrs to acclimate to the test flume water and another 5 to 20 min to acclimate to the test cage. Two different testing procedures were used for the tests with larger fish. In the first procedure, the screen velocity was started at a set rate and then increased 0.06 m/sec (0.2 ft/sec) at 10-min intervals until the maximum rate was reached. The second procedure used a similar incremental increase in velocity, however, the velocities were held constant for 30-min intervals. The specimens were monitored continuously throughout the testing period for impingement, entrainment, and behavior.

The major factors that influenced impingement included intake velocity, fish size, and behavior. The impingement study of larger fish used a total of 1,387 fish representing 20 species (Table 5-5). Intake velocities up to 0.5 m/sec (1.53 ft/sec) were tested with the 1-mm (0.04 in) slot width screen. The majority of the experiments were conducted in the static mode (i.e., no channel flow) with fish contained in close proximity to the screen. The authors assumed that these were worst-case conditions due to constant exposure and lack of bypass currents to lessen entrainment and impingement. Fish interactions with the screens were rare in tests conducted in the dynamic mode (i.e., with channel flow). Impingement and interaction of fish with the screens varied by species. Of the 1,318 fish tested in the static mode, only 20% of the 261 fish that became impinged failed to escape the screen after impingement. The authors suggest that handling stress may have contributed to fish that experienced prolonged impingement. Thirty-four specimens died as a result of testing. The authors note that most of these fish were in poor condition prior to the impingement trials (Hanson et al. 1977).

**Table 5-5**  
**Impingement occurrence (Hanson et al. 1977)**

| Species                | n   | FL (mm) | Intake Velocity (ft/s) | I.O. <sup>a</sup> | Escapes | Fish-min. <sup>b</sup> | Mean Impingement Duration (min.) | Susceptibility Index <sup>c</sup> |
|------------------------|-----|---------|------------------------|-------------------|---------|------------------------|----------------------------------|-----------------------------------|
| alewife                | 37  | 37-65   | 0.50-1.50              | 0                 | --      | --                     | --                               | 0.0000                            |
| Atlantic menhaden      | 77  | 38-145  | 0.50-1.50              | 15                | 12      | 34.25                  | 2.28                             | 0.0164                            |
| bay anchovy            | 68  | 25-71   | 0.50-1.50              | 85                | 73      | 214.95                 | 2.53                             | 0.1202                            |
| carp                   | 39  | 17-30   | 0.00-0.79              | 7                 | 7       | 26.00                  | 3.71                             | 0.0118                            |
| silvery minnow         | 4   | 30-31   | 0.50-1.50              | 0                 | --      | --                     | --                               | 0.0000                            |
| golden shiner          | 14  | 35-56   | 0.21-1.42              | 0                 | --      | --                     | --                               | 0.0000                            |
| spottail shiner        | 34  | 23-77   | 0.50-1.50              | 5                 | 1       | 186.01                 | 37.20                            | 0.2989                            |
| banded killifish       | 10  | 34-89   | 0.96-1.42              | 0                 | --      | --                     | --                               | 0.0000                            |
| mummichog              | 7   | 37-75   | 0.98-1.42              | 0                 | --      | --                     | --                               | 0.0000                            |
| tidewater silverside   | 44  | 27-81   | 0.41-1.50              | 5                 | 5       | 0.29                   | 0.06                             | 0.0001                            |
| Atlantic silverside    | 136 | 34-95   | 0.50-1.50              | 7                 | 7       | 0.09                   | 0.01                             | T <sup>d</sup>                    |
| threespine stickleback | 1   | 23      | 1.00                   | 2                 | 2       | 0.04                   | 0.02                             | 0.0013                            |
| white perch            | 96  | 21-41   | 0.50-1.50              | 24                | 24      | 4.79                   | 0.20                             | 0.0017                            |
| striped bass           | 648 | 8-151   | 0.31-1.50              | 77                | 49      | 996.96                 | 12.95                            | 0.0335                            |
| pumpkinseed            | 3   | 70-91   | 1.50                   | 0                 | --      | --                     | --                               | 0.0000                            |
| bluegill               | 30  | 25-98   | 0.20-1.50              | 0                 | --      | --                     | --                               | 0.0000                            |
| yellow perch           | 18  | 34-40   | 0.50-1.50              | 0                 | --      | --                     | --                               | 0.0000                            |
| bluefish               | 4   | 64-135  | 0.41-1.25              | 0                 | --      | --                     | --                               | 0.0000                            |
| weakfish               | 53  | 31-93   | 0.50-1.50              | 13                | 13      | 0.70                   | 0.05                             | 0.0004                            |
| spot                   | 64  | 36-98   | 0.50-1.50              | 23                | 19      | 71.65                  | 3.12                             | 0.0427                            |

<sup>(a)</sup> I.O. = Impingement Occurrence.

<sup>(b)</sup> Fish-min = the sum of the products of the number of fish and the time exposed to any event.

<sup>(c)</sup> Susceptibility Index =  $[I.O. - E.S. / I.O. + 1] [F.M. / T.F.M.]$   
 where:

I.O. is the number of impingement occurrences

E.S. is the number of escapes

F.M. is fish-min impinged

T.F.M is total fish-min exposed

<sup>(d)</sup> T < 0.00005.

These laboratory studies were followed by in situ tests on the Chesapeake and Delaware Canal. A test facility was installed with a single 1-mm (0.04-in.) slot wedgewire screen capable of withdrawing up to 4.4 m<sup>3</sup>/sec (155 cfs) with a corresponding slot velocity of 0.24 m/sec (0.8 ft/sec). A series of 24-hour studies was conducted once each month from June through September. Samples were taken every 3 hrs in conjunction with concurrent ichthyoplankton tows at a nearby station. The majority of eggs collected were bay anchovy (*Anchoa mitchilli*). White perch (*Morone americana*) and bay anchovy accounted for the majority of larvae collected. Statistical analysis showed that the density of prolarvae, post-larvae, juvenile, and all life stages combined was significantly lower in entrainment samples than in towed ichthyoplankton samples (Hanson et al. 1978).

### **Laboratory Evaluation – Entergy/Alden**

Entergy Nuclear Indian Point 2, LLC and Entergy Nuclear Indian Point 3, LLC (IPEC) sponsored the biological evaluation of cylindrical wedgewire (CWW) screens in 2010 (NAU and ASA 2011a). The purpose of the study was to determine the effectiveness of CWW screens at reducing entrainment of fish eggs and larvae at various slot widths and flow regimes indicative of those found at IPEC. This work expands on previous work sponsored by EPRI (EPRI 2003) and was designed to understand and estimate three mechanisms influencing entrainment: hydraulic bypass, avoidance, and mechanical exclusion.

Testing was conducted at Alden Research Laboratory, Inc (Alden). The flume configuration was designed to emulate EPRI-sponsored evaluations (EPRI 2003), with some modifications made to the fish collection system. Johnson model T-12 screens with slot widths of 2, 3, 6, and 9 mm were tested. Flume velocities were 0.08, 0.15, and 0.30 m/sec (0.25, 0.5, and 1.0 ft/sec) and through-slot velocities were 0.08 and 0.15 m/sec (0.25 and 0.5 ft/sec). A total of 24 test combinations were produced between slot width, flume velocity, and through-slot velocity. Tests were conducted under both ambient light and nighttime conditions. Tests were conducted by releasing neutrally-buoyant beads, fish eggs of approximately 1 and 3 mm diameter, and fish larvae with robust (Atlantic tomcod [*Microgadus tomcod*], striped bass [*Morone saxatilis*]) and slender (white sucker [*Catostomus commersonii*]) body forms at a location of known high probability of entrainment immediately upstream of the test screen. The length, body depth, and number of the test subjects carried past, entrained through, or excluded and retained on the cylindrical wedgewire screen was recorded. Various species of fish larvae (live and dead) and eggs were used. Total length and body depth were recorded in order to relate performance to fish size.

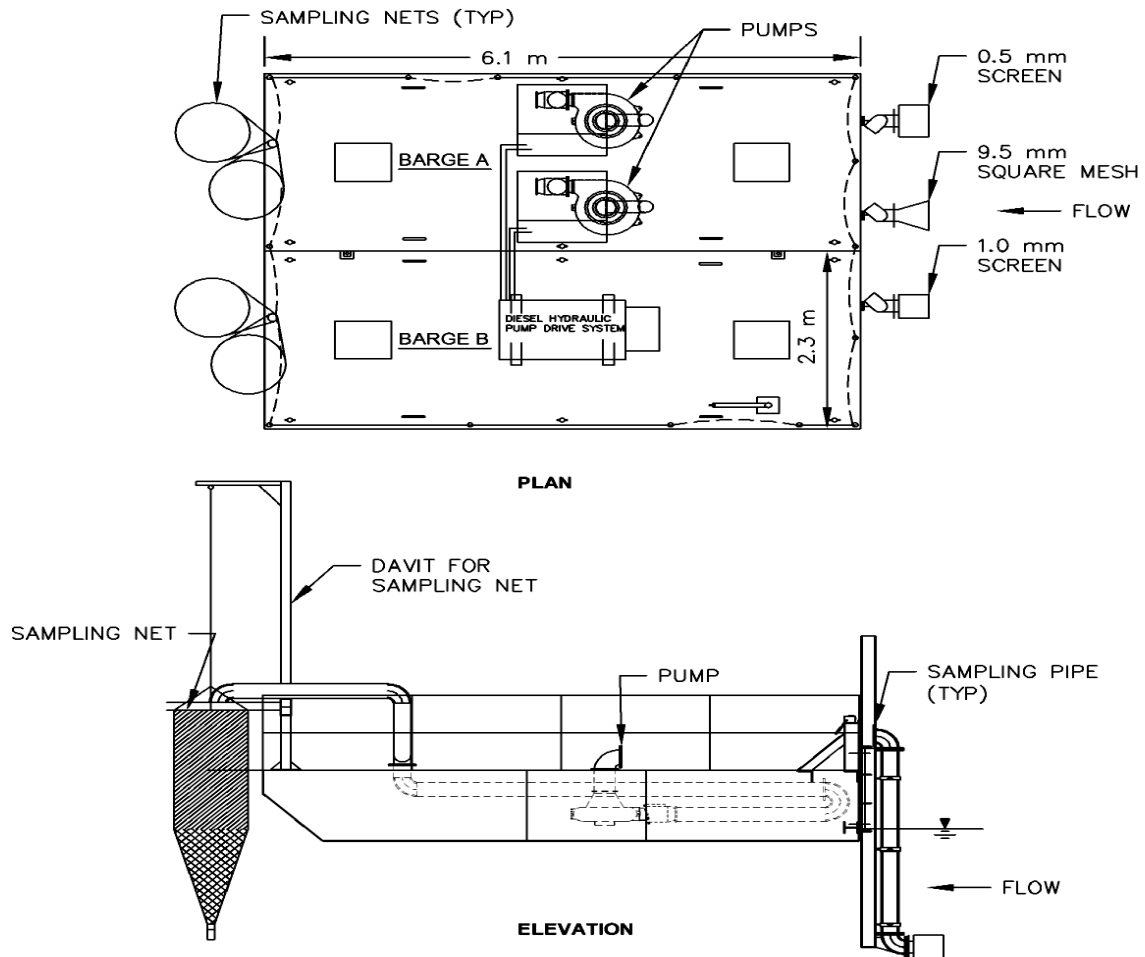
Avoidance was typically higher during the day, for the smaller slot sizes, for the lower through-slot velocity, and at higher ratios of flume/slot velocity. Exclusion of live larvae was reduced as slot velocity increased on the 2 mm screen. Exclusion of white sucker eggs (3.3-mm diameter) by the 2-mm screen was nearly 100% at either through-slot velocity, but was somewhat lower (70%-95%) with the 3-mm screen. The probability of being swept off, if excluded, was higher for the white sucker eggs than for fish larvae, was higher for the low through-slot velocity (0.08 m/sec [0.25 ft/sec]), and increased with increasing flume velocity. The 2010 laboratory study confirmed that avoidance of the cylindrical wedgewire screens tested occurs for fish larvae, and that the ability to avoid the screen increases exponentially with length (NAI and ASA 2011a).

The laboratory studies were repeated in 2011 (NAI and ASA 2011b). The first objective was to supplement the testing conducted in 2010 by repeating the 2010 test procedure for flume velocities of 0.15, 0.30, 0.46, 0.61 m/sec (0.5, 1.0, 1.5, and 2.0 ft/sec). The second objective of the 2011 laboratory study was to further refine the means of estimating the efficacy of the full-scale T-72 (1.8-m [72-in.] diameter screens in “T” configuration) cylindrical wedgewire screens that are proposed for implementation at the IPEC. This objective was to be accomplished by (1) conducting additional laboratory flume studies in 2011, (2) conducting CFD modeling in support of the flume studies, and (3) integrating the new information from 2011 with the studies done in 2010. Efficacy of the screens appears to be related to the ambient velocity flowing past the screens through two complementary effects. Efficacy is the probability that an organism encountering the screen will not be entrained and is the combination of hydraulic bypass, avoidance, and, potentially, exclusion for larger organisms. Combination of these three mechanisms generally resulted in an increase in efficacy as ambient velocity increased. The 2011 studies, using data obtained from the T-12 and T-18 screens tested in the lab, found no effect of the length of screen on efficacy. Larval length was an important factor in determining avoidance capability, and therefore also overall efficacy of the screens (NAI 2011b).

### ***Field Evaluation - Narragansett Bay, RI; Portage River, OH; and Chesapeake Bay, VA***

The Electric Power Research Institute (EPRI) conducted field evaluations of narrow-slot wedgewire screens to examine entrainment rates of naturally-occurring fish species and life stages at three sites with unique hydraulic and environmental conditions (EPRI 2005, EPRI 2006b). The previous EPRI laboratory study (EPRI 2003) identified key aspects of design and operation that affect the biological performance of narrow-slot wedgewire screens. The subsequent EPRI field studies were conducted as follow-up testing to quantify the effects of environmental variables, such as non-uniform flows, debris, and biofouling, on entrainment of ichthyoplankton. Specifically, the initial objective was to estimate entrainment rates of naturally-occurring fish species from one estuarine site and one freshwater site through 0.5- and 1.0-mm (0.02- and 0.04-in.) wedgewire screens. A second estuarine site was selected for testing after the first year of study was completed at the first two sites.

A floating barge test facility was constructed specifically for the field evaluations of wedgewire screens (Figure 5-12). The barge had intakes for two wedgewire screens and an open port on the bow. The port-side intake was capped with a 0.5-mm (0.02-in.) slot cylindrical screen and the starboard-side intake was capped with a 1.0-mm (0.04-in.) slot cylindrical screen. The open port was capped with a 9.5-mm (3/8-in.) coarse debris screen and was located between the two wedgewire screen intakes. Two hydraulically driven fish pumps were used to withdraw water through the open port (control) intake and either one of the two wedgewire screen (treatment) intakes. Water was discharged into 335- $\mu$ m mesh plankton nets to collect entrained ichthyoplankton. Ambient ichthyoplankton density was determined by sampling from the side of the barge with a 335- $\mu$ m mesh plankton net.



**Figure 5-12**

**Test facility in plan and elevation view (EPRI 2005). Note that flexible hoses connecting pumps to sampling pipes have been omitted from both views and the diesel hydraulic pump drive has been omitted from the elevation view for clarity.**

The two test screens were constructed of single-screen, stainless steel, wedgewire (Johnson Screens). The control intake simulated the conical intakes found at the majority of conventional traveling water screens. The 0.5-mm (0.02-in.) screen was 41 cm (16.1 in.) in diameter and 46 cm (18.1 in.) in length with a discharge diameter of 20 cm (7.9 in.). The 1.0-mm (0.04 in.) screen was 30 cm (11.8 in.) in diameter and 36 cm (14.2 in.) in length with a discharge diameter of 15 cm (5.9 in.). Porosities of the 0.5-mm (0.02-in.) screen, 1.0-mm (0.04-in.) screen, and the 9.5-mm (0.37-in.) mesh-covered control port were 23.8, 38.5, and 70.6% respectively. Sizing of

the wedgewire screens and control intake were such that respective through-slot velocities were equal for each intake at a given flow rate.

The first estuarine site selected for testing was on the Sakonnet River within Narragansett Bay and was selected for its abundance of target species and absence of dredging activity. Testing was conducted five to seven days per week in April and May of 2004. The barge was moored approximately 100 m (328 ft) from the eastern shore of the river in 15.7 m (51.5 ft) deep water. The intakes were positioned at a depth 1.5 m ([5 ft] on center) below the water surface. Six trials averaging 55 min in duration were completed daily. Sampling was conducted from one hour after high tide until one hour after low tide.

The independent variables evaluated in this study included slot width (0.5 and 1.0 mm [0.02 and 0.04 in.]), screen slot velocity (0.15 and 0.30 m/sec [0.5 and 1.0 ft/sec]), and ambient velocity (0 to 1.1 m/sec [0 to 3.6 ft/sec]). Each combination of treatment conditions was replicated 10 times. All collected larvae were enumerated, identified to species when possible, and preserved for subsequent analysis. A subset of individuals was measured for length and head capsule depth (HCD). An ambient sample averaging 60 m<sup>3</sup> (2,119 ft<sup>3</sup>) was collected with a plankton net towed 20 m (65.5 ft) downstream of the test facility at a depth of 1.5 m (5 ft). This ambient sample served to characterize species composition and densities. Comparative densities of entrained eggs and larvae between paired test and control intakes provided relative effectiveness measurements of entrainment reduction.

The freshwater site was located on the Portage River approximately 600 m (1,968.5 ft) upstream of Lake Erie. This site was selected for its high concentrations of target Great Lakes species. Testing was conducted seven days a week in May and June of 2004 and is procedurally similar to the Sakonnet River site unless otherwise noted. The barge was moored in 2.4 m (8 ft) deep water. The intakes were positioned 1.2 m (4 ft) below the water surface. Unlike the tidal estuarine sites, the effects of ambient water velocity could not be ascertained due to the absence of any predictable variation in water velocities. Therefore, two trials, averaging 4 hrs in duration, were conducted daily to maximize sample sizes. Each pair of trials evaluated the same slot size, but different slot velocities. Each test condition was replicated 10 times. To minimize mechanical damage to larvae, entrainment nets were rinsed hourly during each 4-hour trial. All collected larvae were enumerated, identified to species when possible, and preserved for subsequent analysis. An ambient ichthyoplankton sample averaging 60 m<sup>3</sup> (2,119 ft<sup>3</sup>) was collected for each trial by towing a plankton net 20 m (65.6 ft) behind a john boat. Comparisons between treatment and control entrainment densities were analyzed as described above for the Sakkonet River site.

A total of 11 species of larval fish were collected during the Sakonnet River sampling. Sand lance (*Ammodytes americanus*), winter flounder (*Pseudopleuronectes americanus*), and grubby (*Myoxocephalus aeneus*) comprised 51, 34, and 13%, respectively, of all larval fish collected. These were the only species collected in sufficient quantity for statistical analysis. A total of 15 species of larval fishes were collected during the Portage River sampling. While 93% of all larvae collected at this freshwater site were shad species (Clupeidae), sufficient numbers of carp (Cyprinidae), freshwater drum (*Aplodinotus grunniens*), and temperate basses (Morone spp.) were collected to allow statistical analysis.

The mean densities of all larvae and eggs collected in treatment, control, and ambient samples during Sakonnet River testing are presented in Table 5-6 through Table 5-10. For grubby, the



0.5-mm (0.02-in.) screen significantly reduced entrainment by more than 92% for all length classes combined. For larvae greater than 7 mm (0.28 in.) in length, the reduction increased to 100%. The 1.0-mm (0.04-in.) screen significantly reduced entrainment of grubby over 7 mm (0.28 in.) by 84%. The 0.5-mm (0.02-in.) screen significantly reduced the entrainment of sand lance by 80 and 93% for all length classes combined. The 1.0-mm (0.04-in.) screen offered no significant reduction in entrainment for sand lance. For winter flounder, which were considerably smaller than other species, the 0.5-mm (0.02-in.) screen significantly reduced entrainment of all combined length classes by 44 -56%. The 1.0-mm (0.04-in.) screen did not offer any significant reduction in entrainment to winter flounder. Overall, the 0.5-mm (0.02-in.) screen reduced the entrainment of all larvae at the Sakonnet River site by 82 and 72% at the 0.15 and 0.30 m/sec (0.5 and 1.0 ft/sec) slot velocities, respectively. For all larvae combined, the 1.0-mm (0.04-in.) screen offered no significant reduction in entrainment at either slot velocity. The 0.5-mm (0.02-in.) screen significantly reduced the entrainment of eggs by 93 and 100% at slot velocities of 0.15 and 0.30 m/sec (0.5 and 1.0 ft/sec), respectively (Table 5-10). Although mean densities were lower in treatment samples, no significant reduction in the entrainment of eggs was observed with the 1.0-mm (0.04-in.) screen.

The mean densities of all larvae and eggs collected in treatment, control, and ambient samples during Portage River testing are presented in Table 5-11 through Table 5-15. For shad, the 0.5-mm (0.02-in.) screen only produced a significant reduction in entrainment (98% reduction) at a slot velocity of 0.15 m/sec (0.5 ft/sec) for fish between 7 and 9 mm (0.28 and 0.35 in.). Similarly, the 1.0-mm (0.04-in.) screen only produced a significant reduction in entrainment under one test condition, a 47% reduction at a slot velocity of 0.30 m/sec (1.0 ft/sec) for fish between 4 and 6 mm (0.16 and 3.8 in.). For carp, the 0.5-mm (0.02-in.) screen produced no significant reduction in entrainment, while the 1.0-mm (0.04-in.) screen did at 0.30 m/sec (1.0 ft/sec). For freshwater drum, there were no significant reductions in entrainment at any test conditions despite large differences between treatment and control densities. For temperate basses, despite reductions over controls of over 65% for each test condition, the statistical analysis revealed no significant differences in densities. The paucity of carp, freshwater drum, and temperate bass collected during this study (less than 5% of the total) limited the statistical power of the analysis. The 0.5-mm (0.02-in.) screen significantly reduced the entrainment of eggs by 98 and 93% at slot velocities of 0.15 and 0.30 m/sec (0.5 and 1.0 ft/sec), respectively (Table 5-15). Although the mean density of eggs at 0.15 m/sec (0.5 ft/sec) with the 1.0-mm (0.04-in.) screen was considerably lower, no significant reduction was detected in the analysis.

**Table 5-6**

**Mean density and standard deviation (SD) of grubby larvae collected at the Sakkonet River site in ambient, control, and test samples during trials with 0.5 and 1.0 mm screens at slot velocities of 0.15 and 0.30 m/sec (EPRI 2005). C-T is the percent difference between test and control densities.<sup>a</sup> Asterisks indicate a statistically significant difference between test and control densities ( $p < 0.05$ ).**

| Slot Width (mm) | Slot Velocity (m/sec) | Larval Length (mm) | Mean Number Entrained per 100 m <sup>3</sup> (SD) |             |            | C-T Percent Difference (Valid Trials) |
|-----------------|-----------------------|--------------------|---------------------------------------------------|-------------|------------|---------------------------------------|
|                 |                       |                    | Ambient                                           | Control     | Test       |                                       |
| 0.5             | 0.15                  | ≤3                 | 0.7 (2.4)                                         | 0.9 (2.4)   | 0.1 (0.4)  | 92.5 (7)                              |
|                 |                       | 4-6                | 12.2 (15.5)                                       | 8.9 (14.0)  | 0.4 (0.9)  | 95.8 (19)*                            |
|                 |                       | 7-9                | 5.9 (7.9)                                         | 3.2 (7.2)   | 0.0 (0.0)  | 100.0 (10)*                           |
|                 |                       | ≥10                | 0.8 (1.3)                                         | 0.7 (1.7)   | 0.0 (0.0)  | 100.0 (5)*                            |
|                 |                       | All                | 19.5 (23.2)                                       | 13.7 (23.2) | 0.4 (1.2)  | 96.7 (19)*                            |
|                 | 0.30                  | ≤3                 | 0.0 (0.0)                                         | 0.1 (0.5)   | 0.0 (0.2)  | 77.8 (4)                              |
|                 |                       | 4-6                | 8.9 (9.2)                                         | 7.6 (13.8)  | 0.7 (1.1)  | 90.2 (23)*                            |
|                 |                       | 7-9                | 1.6 (3.3)                                         | 2.3 (4.9)   | 0.0 (0.0)  | 100.0 (12)*                           |
|                 |                       | ≥10                | 0.5 (0.7)                                         | 0.4 (0.8)   | 0.0 (0.0)  | 100.0 (7)*                            |
|                 |                       | All                | 12.5 (11.4)                                       | 10.4 (18.0) | 0.8 (1.1)  | 92.5 (23)*                            |
| 1.0             | 0.15                  | ≤3                 | 0.6 (2.0)                                         | 1.5 (3.9)   | 0.8 (2.5)  | 44.6 (13)                             |
|                 |                       | 4-6                | 6.5 (5.8)                                         | 7.3 (16.6)  | 4.8 (9.3)  | 33.7 (26)                             |
|                 |                       | 7-9                | 1.8 (4.8)                                         | 1.8 (4.4)   | 0.3 (1.6)  | 83.8 (9)*                             |
|                 |                       | ≥10                | 0.8 (2.1)                                         | 0.2 (0.9)   | 0.0 (0.0)  | N/A <sup>b</sup>                      |
|                 |                       | All                | 9.9 (10.3)                                        | 10.8 (22.8) | 6.0 (11.8) | 44.5 (26)*                            |
|                 | 0.30                  | ≤3                 | 0.3 (0.9)                                         | 0.5 (0.9)   | 0.2 (0.4)  | 63.2 (7)                              |
|                 |                       | 4-6                | 3.7 (6.4)                                         | 5.2 (12.0)  | 3.3 (6.2)  | 35.9 (18)                             |
|                 |                       | 7-9                | 2.6 (5.6)                                         | 1.7 (3.5)   | 0.2 (0.9)  | 89.1 (10)*                            |
|                 |                       | ≥10                | 2.0 (4.9)                                         | 0.0 (0.2)   | 0.0 (0.0)  | N/A <sup>b</sup>                      |
|                 |                       | All                | 8.6 (16.5)                                        | 7.3 (15.3)  | 3.7 (7.0)  | 50.1 (21)*                            |

<sup>a</sup> "C-T Percent Difference" is calculated as [(control density minus test density) divided by control density]. Thus, positive values indicate lower densities in test samples.

<sup>b</sup> Insufficient data for meaningful comparison.

**Table 5-7**

**Mean density and standard deviation (SD) of sand lance larvae collected at the Sakkonet River site in ambient, control, and test samples during trials with 0.5 and 1.0 mm screens at slot velocities of 0.15 and 0.30 m/sec (EPRI 2005). C-T is the percent difference between test and control densities.<sup>a</sup> Asterisks indicate a statistically significant difference between test and control densities ( $p < 0.05$ ).**

| Slot Width (mm) | Slot Velocity (m/sec) | Larval Length (mm) | Mean Number Entrained per 100 m <sup>3</sup> (SD) |              |             | C-T Percent Difference (Valid Trials) |
|-----------------|-----------------------|--------------------|---------------------------------------------------|--------------|-------------|---------------------------------------|
|                 |                       |                    | Ambient                                           | Control      | Test        |                                       |
| 0.5             | 0.15                  | ≤5                 | 0.0 (0.0)                                         | 0.8 (1.7)    | 0.2 (0.6)   | 78.6 (6)*                             |
|                 |                       | 6-10               | 57.6 (80.2)                                       | 43.6 (102.9) | 2.9 (7.5)   | 93.4 (16)*                            |
|                 |                       | 11-15              | 34.9 (45.0)                                       | 4.7 (13.6)   | 0.1 (0.3)   | 98.8 (8)*                             |
|                 |                       | ≥16                | 0.7 (1.4)                                         | 0.1 (0.5)    | 0.0 (0.0)   | 100.0 (2)                             |
|                 |                       | All                | 91.6 (114.6)                                      | 47.5 (112.6) | 3.2 (7.5)   | 93.3 (17)*                            |
|                 | 0.30                  | ≤5                 | 0.0 (0.0)                                         | 1.1 (3.0)    | 0.9 (1.9)   | 15.0 (11)                             |
|                 |                       | 6-10               | 38.5 (56.0)                                       | 20.0 (35.9)  | 4.0 (9.1)   | 80.0 (20)*                            |
|                 |                       | 11-15              | 28.8 (97.4)                                       | 1.3 (2.4)    | 0.1 (0.2)   | 95.9 (12)*                            |
|                 |                       | ≥16                | 5.8 (17.4)                                        | 0.3 (1.0)    | 0.0 (0.0)   | 100.0 (4)                             |
|                 |                       | All                | 87.5 (134.4)                                      | 24.9 (38.9)  | 4.9 (9.8)   | 80.2 (23)*                            |
| 1.0             | 0.15                  | ≤5                 | 0.0 (0.0)                                         | 0.9 (2.1)    | 1.0 (3.1)   | -15.3 (8)                             |
|                 |                       | 6-10               | 41.5 (49.3)                                       | 10.3 (16.1)  | 13.4 (20.0) | -29.8 (23)                            |
|                 |                       | 11-15              | 32.6 (49.8)                                       | 1.4 (2.9)    | 1.1 (3.6)   | 23.9 (11)                             |
|                 |                       | ≥16                | 7.6 (25.3)                                        | 0.2 (1.1)    | 0.0 (0.0)   | N/A <sup>b</sup>                      |
|                 |                       | All                | 81.8 (89.8)                                       | 12.8 (18.8)  | 15.5 (23.0) | -20.8 (24)                            |
|                 | 0.30                  | ≤5                 | 0.0 (0.0)                                         | 0.8 (1.7)    | 0.9 (2.3)   | -13.2 (9)                             |
|                 |                       | 6-10               | 61.0 (88.4)                                       | 20.0 (40.1)  | 19.5 (33.3) | 2.5 (14)                              |
|                 |                       | 11-15              | 50.1 (51.9)                                       | 1.0 (1.6)    | 1.4 (2.5)   | -43.7 (9)                             |
|                 |                       | ≥16                | 29.8 (39.5)                                       | 0.2 (0.3)    | 0.0 (0.0)   | 100.0 (4)                             |
|                 |                       | All                | 111.8 (122.1)                                     | 19.0 (35.4)  | 18.6 (33.1) | 2.2 (21)                              |

<sup>a</sup> "C-T Percent Difference" is calculated as [(control density minus test density) divided by control density]. Thus, positive values indicate lower densities in test samples.

<sup>b</sup> Insufficient data for meaningful comparison.

**Table 5-8**

**Mean density and standard deviation (SD) of winter flounder larvae collected at the Sakkonet River site in ambient, control, and test samples during trials with 0.5 and 1.0 mm screens at slot velocities of 0.15 and 0.30 m/sec (EPRI 2005). C-T is the percent difference between test and control densities.<sup>a</sup> Asterisks indicate a statistically significant difference between test and control densities ( $p < 0.05$ ).**

| Slot Width (mm) | Slot Velocity (m/sec) | Larval Length (mm) | Mean Number Entrained per 100 m <sup>3</sup> (SD) |             |             | C-T Percent Difference (Valid Trials) |
|-----------------|-----------------------|--------------------|---------------------------------------------------|-------------|-------------|---------------------------------------|
|                 |                       |                    | Ambient                                           | Control     | Test        |                                       |
| 0.5             | 0.15                  | ≤3                 | 13.5 (12.9)                                       | 12.3 (12.0) | 8.2 (11.8)  | 33.6 (24)*                            |
|                 |                       | 4-6                | 16.0 (14.0)                                       | 13.4 (18.3) | 3.1 (5.4)   | 76.9 (20)*                            |
|                 |                       | 7-9                | 1.9 (2.3)                                         | 0.0 (0)     | 0.0 (0.0)   | N/A <sup>b</sup>                      |
|                 |                       | ≥10                | 0.0 (0.0)                                         | 0.0 (0)     | 0.0 (0.0)   | N/A <sup>b</sup>                      |
|                 |                       | All                | 31.4 (19.5)                                       | 25.7 (26.0) | 11.3 (14.7) | 56.2 (24)*                            |
|                 | 0.30                  | ≤3                 | 17.5 (16.9)                                       | 6.0 (5.3)   | 5.3 (5.9)   | 10.9 (26)                             |
|                 |                       | 4-6                | 45.6 (82.5)                                       | 11.4 (12.4) | 4.4 (6.6)   | 61.2 (24)*                            |
|                 |                       | 7-9                | 5.0 (13.5)                                        | 0.0 (0.2)   | 0.0 (0.2)   | -30.6 (2)                             |
|                 |                       | ≥10                | 0.0 (0.0)                                         | 0.0 (0.0)   | 0.0 (0.0)   | N/A <sup>b</sup>                      |
|                 |                       | All                | 77.0 (89.9)                                       | 17.4 (15)   | 9.8 (11.0)  | 43.8 (26)*                            |
| 1.0             | 0.15                  | ≤3                 | 30.0 (22.0)                                       | 10.1 (8.8)  | 12.0 (9.0)  | -18.6 (30)                            |
|                 |                       | 4-6                | 34.5 (19.8)                                       | 10.0 (10.2) | 9.4 (12.0)  | 5.8 (31)                              |
|                 |                       | 7-9                | 3.1 (8.0)                                         | 0.3 (1.1)   | 0.3 (1.5)   | -16.4 (4)                             |
|                 |                       | ≥10                | 0.1 (0.4)                                         | 0.0 (0.0)   | 0.0 (0.0)   | N/A <sup>b</sup>                      |
|                 |                       | All                | 67.7 (29.8)                                       | 20.4 (16.2) | 21.7 (17.0) | -6.7 (31)                             |
|                 | 0.30                  | ≤3                 | 18.2 (16.5)                                       | 5.9 (6.1)   | 4.3 (4.9)   | 26.6 (24)                             |
|                 |                       | 4-6                | 14.7 (12.6)                                       | 9.0 (8.8)   | 8.0 (11.0)  | 11.0 (22)                             |
|                 |                       | 7-9                | 0.7 (1.4)                                         | 0.2 (0.6)   | 0.1 (0.3)   | 44.2 (4)                              |
|                 |                       | ≥10                | 0.0 (0.0)                                         | 0.0 (0.0)   | 0.0 (0.0)   | N/A <sup>b</sup>                      |
|                 |                       | All                | 33.3 (20.6)                                       | 14.5 (14.7) | 12.1 (13.1) | 16.9 (25)                             |

<sup>a</sup> "C-T Percent Difference" is calculated as [(control density minus test density) divided by control density]. Thus, positive values indicate lower densities in test samples.

<sup>b</sup> Insufficient data for meaningful comparison.

**Table 5-9**

**Mean density and standard deviation (SD) of larvae (all species) collected at the Sakkonet River site in ambient, control, and test samples during trials with 0.5 and 1.0 mm screens at slot velocities of 0.15 and 0.30 m/sec (EPRI 2005). C-T is the percent difference between test and control densities.<sup>a</sup> Asterisks indicate a statistically significant difference between test and control densities ( $p < 0.05$ ).**

| Slot Width (mm) | Slot Velocity (m/sec) | Larval Length (mm) | Mean Number Entrained per 100 m <sup>3</sup> (SD) |              |             | C-T Percent Difference (Valid Trials) |
|-----------------|-----------------------|--------------------|---------------------------------------------------|--------------|-------------|---------------------------------------|
|                 |                       |                    | Ambient                                           | Control      | Test        |                                       |
| 0.5             | 0.15                  | ≤3                 | 13.5 (11.7)                                       | 12.7 (12.2)  | 7.7 (11.1)  | 39.2 (28)*                            |
|                 |                       | 4-6                | 32.7 (28.6)                                       | 24.6 (30.6)  | 4.6 (7.2)   | 81.2 (25)*                            |
|                 |                       | 7-9                | 39.8 (56.4)                                       | 28.1 (69.5)  | 1.7 (5.3)   | 93.8 (18)*                            |
|                 |                       | ≥10                | 49.5 (70.4)                                       | 15.8 (46.0)  | 0.2 (0.8)   | 98.8 (13)*                            |
|                 |                       | All                | 135.5 (133.5)                                     | 81.1 (144.8) | 14.5 (19.6) | 82.2 (29)*                            |
|                 | 0.30                  | ≤3                 | 18.1 (16.4)                                       | 6.1 (5.5)    | 5.0 (5.7)   | 17.2 (29)                             |
|                 |                       | 4-6                | 52.1 (82.0)                                       | 23.8 (29.5)  | 6.4 (9.1)   | 73.2 (27)*                            |
|                 |                       | 7-9                | 30.0 (45.0)                                       | 17.3 (28.3)  | 2.6 (6.6)   | 85.2 (23)*                            |
|                 |                       | ≥10                | 88.6 (177.5)                                      | 5.3 (8.1)    | 0.1 (0.6)   | 97.2 (19)*                            |
|                 |                       | All                | 210.5 (194.7)                                     | 52.6 (65.2)  | 14.5 (17.7) | 72.4 (29)*                            |
| 1.0             | 0.15                  | ≤3                 | 30.2 (21.9)                                       | 11.7 (9.8)   | 12.7 (9.5)  | -8.4 (31)                             |
|                 |                       | 4-6                | 41.6 (18.6)                                       | 18.2 (21.2)  | 16.2 (20.0) | 10.7 (32)                             |
|                 |                       | 7-9                | 32.9 (43.2)                                       | 10.0 (15.8)  | 10.1 (16.3) | -0.3 (23)                             |
|                 |                       | ≥10                | 61.7 (79.1)                                       | 3.6 (7.7)    | 3.1 (8.9)   | 14.5 (16)                             |
|                 |                       | All                | 166.4 (96.8)                                      | 43.5 (44.7)  | 42.2 (42.1) | 2.9 (32)                              |
|                 | 0.30                  | ≤3                 | 18.8 (15.6)                                       | 5.8 (6.2)    | 4.7 (5.0)   | 18.9 (29)                             |
|                 |                       | 4-6                | 18.0 (15.7)                                       | 18.5 (24.4)  | 15.1 (22.1) | 18.5 (28)                             |
|                 |                       | 7-9                | 41.2 (79.1)                                       | 14.3 (27.8)  | 12.4 (23.8) | 13.0 (24)                             |
|                 |                       | ≥10                | 75.1 (89.1)                                       | 3.7 (4.1)    | 2.8 (5.3)   | 23.1 (25)                             |
|                 |                       | All                | 153.2 (147.0)                                     | 43.3 (56.5)  | 35.7 (49.3) | 17.6 (30)                             |

<sup>a</sup> "C-T Percent Difference" is calculated as [(control density minus test density) divided by control density]. Thus, positive values indicate lower densities in test samples.

**Table 5-10**

Mean density and standard deviation (SD) of eggs collected at the Sakonnet River site in ambient, control, and test samples during trials with 0.5 and 1.0 mm screens at slot velocities of 0.15 and 0.30 m/sec (EPRI 2005). C-T is the percent difference between test and control densities.<sup>a</sup> Asterisks indicate a statistically significant difference between test and control densities ( $p < 0.05$ ).

| Slot Width (mm) | Slot Velocity (m/sec) | Mean Number Entrained per 100 m <sup>3</sup> (SD) |             |             | C-T Percent Difference (Valid Trials) |
|-----------------|-----------------------|---------------------------------------------------|-------------|-------------|---------------------------------------|
|                 |                       | Ambient                                           | Control     | Test        |                                       |
| 0.5             | 0.15                  | 14.2 (12.1)                                       | 14.5 (10.8) | 1.1 (5.9)   | 92.5 (26)*                            |
|                 | 0.30                  | 44.0 (55.6)                                       | 22.8 (25.0) | 0.0 (0.1)   | 99.9 (30)*                            |
| 1.0             | 0.15                  | 60.6 (42.2)                                       | 42.0 (39.0) | 30.6 (23.2) | 27.0 (32)                             |
|                 | 0.30                  | 38.2 (42.9)                                       | 42.9 (42.8) | 39.6 (37.1) | 7.7 (29)                              |

<sup>a</sup> "C-T Percent Difference" is calculated as [(control density minus test density) divided by control density]. Thus, positive values indicate lower densities in test samples.

**Table 5-11**

Mean density and standard deviation (SD) of carp spp. larvae collected at the Portage River site in ambient, control, and test samples during trials with 0.5 and 1.0 mm screens at slot velocities of 0.15 and 0.30 m/sec (EPRI 2005). C-T is the percent difference between test and control densities.<sup>a</sup> Asterisks indicate a statistically significant difference between test and control densities ( $p < 0.05$ ).

| Slot Width (mm) | Slot Velocity (m/sec) | Mean Number Entrained per 100 m <sup>3</sup> (SD) |           |           | C-T Percent Difference (Valid Trials) |
|-----------------|-----------------------|---------------------------------------------------|-----------|-----------|---------------------------------------|
|                 |                       | Ambient                                           | Control   | Test      |                                       |
| 0.5             | 0.15                  | 0.3 (0.9)                                         | 2.2 (5.6) | 2.7 (7.2) | -22.1 (7)                             |
|                 | 0.30                  | 0.0 (0.0)                                         | 1.5 (2.9) | 1.1 (1.5) | 22.3 (6)                              |
| 1.0             | 0.15                  | 3.6 (7.4)                                         | 1.3 (2.5) | 2.1 (3.7) | -65.5 (6)                             |
|                 | 0.30                  | 12.4 (25.2)                                       | 6.0 (9.3) | 2.7 (5.1) | 54.3 (7)*                             |

<sup>a</sup> "C-T Percent Difference" is calculated as [(control density minus test density) divided by control density]. Thus, positive values indicate lower densities in test samples.

**Table 5-12**

Mean density and standard deviation (SD) of freshwater drum larvae collected at the Portage River site in ambient, control, and test samples during trials with 0.5 and 1.0 mm screens at slot velocities of 0.15 and 0.30 m/sec (EPRI 2005). C-T is the percent difference between test and control densities.<sup>a</sup> Asterisks indicate a statistically significant difference between test and control densities ( $p < 0.05$ ).

| Slot Width (mm) | Slot Velocity (m/sec) | Mean Number Entrained per 100 m <sup>3</sup> (SD) |             |           | C-T Percent Difference (Valid Trials) |
|-----------------|-----------------------|---------------------------------------------------|-------------|-----------|---------------------------------------|
|                 |                       | Ambient                                           | Control     | Test      |                                       |
| 0.5             | 0.15                  | 1.6 (4.2)                                         | 2.5 (5.5)   | 0.1 (0.2) | 96.4 (4)                              |
|                 | 0.30                  | 43.1 (131.5)                                      | 14.2 (36.4) | 0.6 (1.6) | 95.9 (4)                              |
| 1.0             | 0.15                  | 19.7 (52.0)                                       | 0.0 (0.0)   | 0.1 (0.3) | N/A <sup>b</sup>                      |
|                 | 0.30                  | 199.3 (549.6)                                     | 9.9 (19.9)  | 2.8 (5.5) | 71.7 (2)                              |

<sup>a</sup> "C-T Percent Difference" is calculated as [(control density minus test density) divided by control density]. Thus, positive values indicate lower densities in test samples.

**Table 5-13**

**Mean density and standard deviation (SD) of shad larvae collected at the Portage River site in ambient, control, and test samples during trials with 0.5 and 1.0 mm screens at slot velocities of 0.15 and 0.30 m/sec (EPRI 2005). C-T is the percent difference between test and control densities.<sup>a</sup> Asterisks indicate a statistically significant difference between test and control densities ( $p < 0.05$ ).**

| Slot Width (mm) | Slot Velocity (m/sec) | Larval Length (mm) | Mean Number Entrained per 100 m <sup>3</sup> (SD) |                 |                 | C-T Percent Difference (Valid Trials) |
|-----------------|-----------------------|--------------------|---------------------------------------------------|-----------------|-----------------|---------------------------------------|
|                 |                       |                    | Ambient                                           | Control         | Test            |                                       |
| 0.5             | 0.15                  | ≤3                 | 46.4 (83.5)                                       | 51.6 (91.6)     | 59.6 (127.2)    | -15.5 (9)                             |
|                 |                       | 4-6                | 662.5 (884.2)                                     | 88.2 (62.4)     | 57.1 (94.4)     | 35.2 (8)                              |
|                 |                       | 7-9                | 535.1 (1,017.7)                                   | 8.4 (9.5)       | 0.1 (0.4)       | 98.2 (5)*                             |
|                 |                       | ≥10                | 28.4 (69.5)                                       | 0.0 (0.0)       | 0.0 (0.0)       | N/A <sup>b</sup>                      |
|                 |                       | All                | 1,272.6 (1,931.4)                                 | 148.2 (148.6)   | 116.9 (220.3)   | 21.1 (9)                              |
|                 | 0.30                  | ≤3                 | 182.3 (357.5)                                     | 72.7 (98.8)     | 63.9 (90.6)     | 12.1 (10)                             |
|                 |                       | 4-6                | 822.3 (1,591.5)                                   | 138.4 (122.2)   | 53.1 (50.4)     | 61.6 (10)*                            |
|                 |                       | 7-9                | 373.0 (790.9)                                     | 28.8 (51.6)     | 6.3 (9.9)       | 78.1 (6)                              |
|                 |                       | ≥10                | 10.6 (24.9)                                       | 4.5 (11.2)      | 0.0 (0.0)       | 100.0 (2)                             |
|                 |                       | All                | 1,388.3 (2,365.2)                                 | 244.4 (182.4)   | 123.3 (125.3)   | 49.5 (10)*                            |
| 1.0             | 0.15                  | ≤3                 | 83.4 (139.2)                                      | 97.2 (92.4)     | 54.4 (75.9)     | 44.0 (7)                              |
|                 |                       | 4-6                | 1,902.5 (3,036.2)                                 | 497.0 (1,061.2) | 455.9 (1,119.4) | 8.3 (7)                               |
|                 |                       | 7-9                | 237.1 (323.2)                                     | 20.7 (39.2)     | 0.8 (1.5)       | 96.1 (5)                              |
|                 |                       | ≥10                | 3.9 (9.3)                                         | 0.0 (0.0)       | 0.0 (0.0)       | N/A <sup>b</sup>                      |
|                 |                       | All                | 2,226.9 (3,304.0)                                 | 614.9 (1,109.7) | 511.1 (1,097.7) | 16.9 (7)                              |
|                 | 0.30                  | ≤3                 | 158.7 (158.6)                                     | 283.9 (371.9)   | 382.4 (574.5)   | -34.7 (9)                             |
|                 |                       | 4-6                | 937.9 (1,367.7)                                   | 269.8 (230.9)   | 142.9 (168.9)   | 47.0 (9)*                             |
|                 |                       | 7-9                | 56.3 (56.4)                                       | 17.6 (26.1)     | 5.6 (11.2)      | 68.0 (4)                              |
|                 |                       | ≥10                | 4.2 (8.4)                                         | 0.0 (0.0)       | 0.0 (0.0)       | N/A <sup>b</sup>                      |
|                 |                       | All                | 1,157.2 (1,320.3)                                 | 571.3 (533.5)   | 530.9 (628.3)   | 7.1 (9)                               |

<sup>a</sup> "C-T Percent Difference" is calculated as [(control density minus test density) divided by control density]. Thus, positive values indicate lower densities in test samples.

<sup>b</sup> Insufficient data for meaningful comparison.



**Table 5-14**

Mean density and standard deviation (SD) of temperate bass larvae collected at the Portage River site in ambient, control, and test samples during trials with 0.5 and 1.0 mm screens at slot velocities of 0.15 and 0.30 m/sec (EPRI 2005). C-T is the percent difference between test and control densities.<sup>a</sup> Asterisks indicate a statistically significant difference between test and control densities ( $p<0.05$ ).

| Slot Width (mm) | Slot Velocity (m/sec) | Mean Number Entrained per 100 m <sup>3</sup> (SD) |           |           | C-T Percent Difference (Valid Trials) |
|-----------------|-----------------------|---------------------------------------------------|-----------|-----------|---------------------------------------|
|                 |                       | Ambient                                           | Control   | Test      |                                       |
| 0.5             | 0.15                  | 15.3 (25.6)                                       | 1.6 (2.3) | 0.5 (1.1) | 67.7 (6)                              |
|                 | 0.30                  | 15.2 (40.3)                                       | 0.7 (1.5) | 0.2 (0.5) | 65.7 (4)                              |
| 1.0             | 0.15                  | 38.2 (83.9)                                       | 0.4 (1.2) | 0.0 (0.0) | N/A <sup>b</sup>                      |
|                 | 0.30                  | 21.6 (35.9)                                       | 0.4 (0.8) | 0.0 (0.0) | 100.0 (2)                             |

<sup>a</sup> "C-T Percent Difference" is calculated as [(control density minus test density) divided by control density]. Thus, positive values indicate lower densities in test samples.

**Table 5-15**

Mean density and standard deviation (SD) of eggs collected at the Portage River site in ambient, control, and test samples during trials with 0.5 and 1.0 mm screens at slot velocities of 0.15 and 0.30 m/sec (EPRI 2005). C-T is the percent difference between test and control densities.<sup>a</sup> Asterisks indicate a statistically significant difference between test and control densities ( $p<0.05$ ).

| Slot Width (mm) | Slot Velocity (m/sec) | Mean Number Entrained per 100 m <sup>3</sup> (SD) |               |              | C-T Percent Difference (Valid Trials) |
|-----------------|-----------------------|---------------------------------------------------|---------------|--------------|---------------------------------------|
|                 |                       | Ambient                                           | Control       | Test         |                                       |
| 0.5             | 0.15                  | 72.3 (130.2)                                      | 45.1 (81.5)   | 1.1 (3.1)    | 97.5 (7)*                             |
|                 | 0.30                  | 91.5 (199.8)                                      | 42.0 (81.0)   | 2.8 (4.3)    | 93.2 (10)*                            |
| 1.0             | 0.15                  | 74.0 (118.5)                                      | 102.9 (200.0) | 4.5 (5.8)    | 95.7 (10) <sup>b</sup>                |
|                 | 0.30                  | 737.7 (1,806.4)                                   | 117.2 (224.1) | 97.1 (195.5) | 17.1 (9)                              |

<sup>a</sup> "C-T Percent Difference" is calculated as [(control density minus test density) divided by control density]. Thus, positive values indicate lower densities in test samples.

<sup>b</sup>  $p=0.06$

The field evaluation of cylindrical wedgewire screens was successful in collecting a sufficient number of ichthyoplankton to provide meaningful entrainment reduction effectiveness estimates. These estimates were based on a variety of biological factors and design and operational parameters. In some cases, comparisons were hindered by low densities and the inherent variability in ichthyoplankton abundance, which reduced sample sizes and potentially obscured significant results. However, a number of general conclusions can be drawn based on observed differences between ichthyoplankton densities entrained through an open control port and the two test screens. Utilizing a smaller slot width reduced larval and egg entrainment densities. Entrainment density was not significantly affected by slot velocity (0.15 and 0.30 m/sec [0.5 and

1.0 ft/sec]). An increase in ambient velocity resulted in an increase in both control and test larval entrainment densities, while egg entrainment densities were unaffected. Entrainment densities decreased with increasing larval length for both slot widths. In addition, the difference between control and test entrainment densities was greater for species with larger head widths.

EPRI continued the field study in 2005 by conducting testing at a third site located on the Chesapeake Bay in Virginia (EPRI 2006b). The objective was to expand upon the previous research and further develop the existing database by evaluating wedgewire screens in a third waterbody type with a different assemblage of species. The same floating test facility constructed in 2004 for the previous field evaluations was used. The specific test site was at the edge of a dredged channel near Gwynns Island. Water depths ranged between 2.3 and 3.0 m (7.5 and 9.8 ft). Tidal currents ranged between 0 and 0.5 m/sec (0 and 1.64 ft/sec). The screens were operated a depth of 1.2 m (4 ft) for all trials. Due to the paucity of organisms during daytime testing, all trials were conducted at night. Four trials were completed daily and a total of ten replicates were conducted for each condition. The variables evaluated in this study were screen slot width (0.5 and 1.0 mm [0.02 and 0.04 in.]), slot velocity (0.15 and 0.30 m/sec [0.5 and 1.0 ft/sec]), and ambient velocity (0 to 0.5 m/sec [0 to 1.6 ft/sec]). Entrained ichthyoplankton in the discharge nets was collected and preserved for subsequent analysis.

A total of 13 species were collected during testing in the Chesapeake Bay. The most abundant species collected were naked goby (*Gobiosoma bosc*) and bay anchovy (*Anchoa mitchilli*), which combined comprised 70% of the total. Twenty four percent of the collected larvae were not identifiable due to damage during collection, though anecdotal evidence indicated that these larvae were most likely bay anchovy. Separate statistical analyses for bay anchovy and naked goby were conducted with and without damaged larvae included. Mean densities for each of the species collected are presented in Table 5-16 through Table 5-20.

For all species of larvae combined, the 0.5-mm (0.02-in.) screen reduced entrainment by 72 and 58%, respectively, at slot velocities of 0.15 and 0.30 m/sec (0.5 and 1.0 ft/sec). The reduction provided by the 1.0-mm (0.04-in.) screen was 36% (0.15 m/sec [0.5 ft/sec]) and 53% (0.30 m/sec [1.0 ft/sec]). Entrainment of naked goby larvae was significantly reduced by  $\geq 65\%$  by the 0.5-mm (0.02-in.) screen and by  $\geq 52\%$  by the 1.0-mm (0.04-in.) screen. Bay anchovy entrainment was significantly reduced by both the 0.5-mm (0.02-in.) ( $\geq 84\%$ ) and 1.0-mm (0.04-in.) ( $\geq 21\%$ ) screens. The 0.5- and 1.0-mm (0.02- and 0.04-in.) screens significantly reduced entrainment of skillettfish (*Gobiesox strumosus*) larvae by  $\geq 51$  and  $\geq 39\%$ , respectively. Entrainment of striped blenny (*Chasmodes bosquianus*) larvae was significantly reduced by both the 0.5-mm (0.02-in.) ( $\geq 62\%$ ) and 1.0-mm (0.04-in.) ( $\geq 44\%$ ) test screens. Northern pipefish (*Syngnathus fuscus*) entrainment was significantly reduced by  $\geq 79\%$  (0.5-mm [0.02-in.] screen) and  $\geq 53\%$  (1.0-mm [0.04-in.] screen). Both test screens significantly reduced the entrainment of bay anchovy eggs. At the lower slot velocity, this reduction was substantial for the 0.5-mm (0.02-in.) screen (87%). However, at the higher slot velocity, both screens provided minimal entrainment reduction ( $\leq 19\%$ ). At the lower slot velocity, the 1.0-mm (0.04-in.) screen also provided a minimal reduction (12%).

Relative to the control, both the 0.5- and 1.0-mm (0.02- and 0.04-in.) test screens significantly reduced entrainment of fish larvae and eggs, but the reduction was greater with the smaller slot width (0.5- mm [0.02-in.]). Although the effect of slot velocity was variable among different species, the screens were generally more effective in reducing entrainment of eggs and larvae

when the slot velocity was 0.15 m/sec (0.5 ft/sec) (by up to 30%) than when the slot velocity was 0.30 m/sec (1.0 ft/sec). Entrainment reduction increased as ambient velocity (approaching the screen) increased. For all species, entrainment reduction tended to increase with larval length.

The results of this multiple-year study indicate that 0.5- and 1.0-mm (0.02- and 0.04-in.) wedgewire screens have the capability to physically exclude eggs and larvae of the species evaluated (and species with similar critical dimensions). In most cases, the level of exclusion seen with the 0.5-mm (0.02-in.) screen is high enough to meet EPA's 316(b) entrainment reduction performance standard (60-90% reduction in entrainment) under many of the conditions studied.

**Table 5-16**

**Mean density and standard deviation (SD) of naked goby larvae collected at the Chesapeake Bay site in ambient, control, and test samples during trials with 0.5 and 1.0 mm screens at slot velocities of 0.15 and 0.30 m/sec (EPRI 2006b). C-T is the percent difference between test and control densities.**

| Slot Width (mm)             | Slot Velocity (m/sec) | Larval Length (mm) | Mean Number Entrained per 100 m <sup>3</sup> (SD) |               |             | C-T Percent Difference <sup>a</sup> (Valid Trials) |
|-----------------------------|-----------------------|--------------------|---------------------------------------------------|---------------|-------------|----------------------------------------------------|
|                             |                       |                    | Ambient                                           | Control       | Test        |                                                    |
| Naked Goby Larvae Only      |                       |                    |                                                   |               |             |                                                    |
| 0.5                         | 0.15                  | ≤3                 | 30.3 (34.1)                                       | 37.2 (42.5)   | 11.3 (13.8) | 69.6 (17)*                                         |
|                             |                       | 4                  | 42.6 (53.4)                                       | 48 (98.1)     | 6.9 (9.7)   | 85.6 (16)*                                         |
|                             |                       | ≥5                 | 48.2 (47)                                         | 13 (17.5)     | 1.7 (2.3)   | 86.8 (13)*                                         |
|                             |                       | All                | 121 (116.2)                                       | 98.2 (135.6)  | 20 (24.3)   | 79.7 (17)*                                         |
|                             | 0.30                  | ≤3                 | 15 (13.5)                                         | 18.9 (30)     | 11.6 (18.8) | 38.5 (18)*                                         |
|                             |                       | 4                  | 19.3 (32)                                         | 20.1 (24.4)   | 5.1 (8.9)   | 74.5 (16)*                                         |
|                             |                       | ≥5                 | 14.5 (26.9)                                       | 15.6 (27.6)   | 2.6 (5.6)   | 83.4 (14)*                                         |
|                             |                       | All                | 48.8 (68.1)                                       | 54.6 (75.8)   | 19.3 (29.3) | 64.6 (18)*                                         |
| 1.0                         | 0.15                  | ≤3                 | 14.6 (21)                                         | 13.7 (21.6)   | 9.2 (14.6)  | 32.9 (16)                                          |
|                             |                       | 4                  | 10.8 (18.2)                                       | 13.5 (24.5)   | 4.3 (11.1)  | 67.9 (10)*                                         |
|                             |                       | ≥5                 | 12.7 (18)                                         | 8.1 (18.4)    | 3.4 (8)     | 58.5 (8)*                                          |
|                             |                       | All                | 38.1 (54.4)                                       | 35.3 (54.6)   | 16.9 (31.1) | 52.2 (16)*                                         |
|                             | 0.30                  | ≤3                 | 15.8 (25.2)                                       | 27.5 (35.7)   | 17.3 (34.9) | 36.9 (16)*                                         |
|                             |                       | 4                  | 27.1 (69.4)                                       | 28.1 (81.9)   | 7.8 (12.2)  | 72.1 (16)                                          |
|                             |                       | ≥5                 | 36.7 (91.4)                                       | 18.7 (53.8)   | 7.9 (15.8)  | 57.9 (13)                                          |
|                             |                       | All                | 79.6 (182.6)                                      | 74.3 (157.6)  | 33 (53.9)   | 55.5 (18)*                                         |
| Naked Goby + Damaged Larvae |                       |                    |                                                   |               |             |                                                    |
| 0.5                         | 0.15                  | All                | 128.8 (116.9)                                     | 124.4 (145.1) | 38.1 (40.7) | 69.4 (17)*                                         |
|                             | 0.30                  | All                | 74.8 (89.1)                                       | 72.5 (87.4)   | 33.4 (42.6) | 53.9 (19)*                                         |
| 1.0                         | 0.15                  | All                | 56.8 (75.7)                                       | 59.9 (84.6)   | 38.7 (62.8) | 35.3 (17)                                          |
|                             | 0.30                  | All                | 96.6 (199.2)                                      | 96.9 (188.7)  | 45.3 (67.8) | 53.2 (19)                                          |

<sup>a</sup> "C-T Percent Difference" is calculated as [(control density minus test density) divided by control density]. Thus, positive values indicate lower densities in test samples. \*Statistically significant difference between test and control samples (p<0.05) as determined by the Wilcoxon matched pairs test of log-transformed densities.

**Table 5-17**

**Mean density and standard deviation (SD) of bay anchovy larvae collected at the Chesapeake Bay site in ambient, control, and test samples during trials with 0.5 and 1.0 mm screens at slot velocities of 0.15 and 0.30 m/sec (EPRI 2006b). C-T is the percent difference between test and control densities.**

| Slot Width (mm)              | Slot Velocity (m/sec) | Larval Length (mm) | Mean Number Entrained per 100 m <sup>3</sup> (SD) |             |             | C-T Percent Difference <sup>a</sup> (Valid Trials) |
|------------------------------|-----------------------|--------------------|---------------------------------------------------|-------------|-------------|----------------------------------------------------|
|                              |                       |                    | Ambient                                           | Control     | Test        |                                                    |
| Bay Anchovy Larvae Only      |                       |                    |                                                   |             |             |                                                    |
| 0.5                          | 0.15                  | ≤8                 | 4.1 (4.4)                                         | 11 (15.8)   | 2.2 (3.3)   | 80.3 (12)*                                         |
|                              |                       | 9-11               | 24.3 (54.8)                                       | 3.1 (5.1)   | 0.2 (0.6)   | 94.1 (8)*                                          |
|                              |                       | ≥12                | 27.5 (71.1)                                       | 0.9 (2.3)   | 0 (0)       | 100.0 (4) <sup>b</sup>                             |
|                              |                       | All                | 56 (124.7)                                        | 15 (21.8)   | 2.3 (3.6)   | 84.3 (12)*                                         |
|                              | 0.30                  | ≤8                 | 5.1 (6.8)                                         | 6 (11.1)    | 0.9 (1.3)   | 85.5 (13)*                                         |
|                              |                       | 9-11               | 3.9 (6.3)                                         | 1.7 (3.3)   | 0.2 (0.5)   | 88.6 (8)*                                          |
|                              |                       | ≥12                | 2.3 (5.7)                                         | 0.4 (1.3)   | 0 (0.2)     | 89.0 (4) <sup>b</sup>                              |
|                              |                       | All                | 11.4 (15.8)                                       | 8.1 (14.4)  | 1.1 (1.7)   | 86.4 (13)*                                         |
| 1.0                          | 0.15                  | ≤8                 | 18.4 (31.4)                                       | 4.2 (5.9)   | 3.9 (7.4)   | 7.9 (10)                                           |
|                              |                       | 9-11               | 16 (24.6)                                         | 1.4 (2.9)   | 0.9 (1.7)   | 38.9 (8)                                           |
|                              |                       | ≥12                | 12.6 (20.7)                                       | 0.4 (1.1)   | 0 (0)       | 100.0 (2) <sup>b</sup>                             |
|                              |                       | All                | 47 (70.2)                                         | 6 (8.3)     | 4.7 (8.8)   | 20.8 (10)                                          |
|                              | 0.30                  | ≤8                 | 6.1 (9.5)                                         | 2.7 (4.8)   | 1.3 (2.6)   | 52.2 (11)                                          |
|                              |                       | 9-11               | 20.2 (52)                                         | 0.6 (1.5)   | 0.2 (0.5)   | 65.3 (5) <sup>b</sup>                              |
|                              |                       | ≥12                | 8.6 (19.7)                                        | 0.2 (0.5)   | 0.1 (0.2)   | 73.8 (5) <sup>b</sup>                              |
|                              |                       | All                | 34.9 (80.2)                                       | 3.5 (6.1)   | 1.6 (2.7)   | 55.7 (11)                                          |
| Bay Anchovy + Damaged Larvae |                       |                    |                                                   |             |             |                                                    |
| 0.5                          | 0.15                  | All                | 63.7 (123.4)                                      | 41.2 (56.2) | 20.5 (32.9) | 50.3 (15)                                          |
|                              | 0.30                  | All                | 37.4 (53.6)                                       | 26 (27.8)   | 15.2 (20)   | 41.5 (16)*                                         |
| 1.0                          | 0.15                  | All                | 65.7 (95.9)                                       | 30.5 (49.9) | 26.6 (53.8) | 12.9 (15)                                          |
|                              | 0.30                  | All                | 51.9 (96)                                         | 26.1 (40)   | 13.8 (23)   | 47.1 (17)                                          |

<sup>a</sup> "C-T Percent Difference" is calculated as [(control density minus test density) divided by control density]. Thus, positive values indicate lower densities in test samples.

<sup>b</sup> Insufficient data for meaningful comparison.

\*Statistically significant difference between test and control samples (p<0.05) as determined by the Wilcoxon matched pairs test of log-transformed densities.

**Table 5-18**

**Mean density and standard deviation (SD) of skillelfish larvae collected at the Chesapeake Bay site in ambient, control, and test samples during trials with 0.5 and 1.0 mm screens at slot velocities of 0.15 and 0.30 m/sec (EPRI 2006b). C-T is the percent difference between test and control densities.**

| Slot Width (mm) | Slot Velocity (m/sec) | Larval Length (mm) | Mean Number Entrained per 100 m <sup>3</sup> (SD) |           |           | C-T Percent Difference <sup>a</sup> (Valid Trials) |
|-----------------|-----------------------|--------------------|---------------------------------------------------|-----------|-----------|----------------------------------------------------|
|                 |                       |                    | Ambient                                           | Control   | Test      |                                                    |
| 0.5             | 0.15                  | ≤3                 | 1.8 (2.1)                                         | 2 (1.9)   | 0.4 (0.6) | 77.9 (17)*                                         |
|                 |                       | ≥4                 | 0.9 (1.2)                                         | 0.6 (0.9) | 0 (0.2)   | 91.9 (9)*                                          |
|                 |                       | All                | 2.7 (2.4)                                         | 2.5 (2)   | 0.5 (0.6) | 81.2 (18)*                                         |
|                 | 0.30                  | ≤3                 | 3.3 (5.6)                                         | 1.3 (1.3) | 0.8 (1.2) | 41.2 (17)*                                         |
|                 |                       | ≥4                 | 0.6 (1.1)                                         | 0.3 (0.6) | 0 (0.1)   | 91.8 (7)*                                          |
|                 |                       | All                | 3.9 (5.5)                                         | 1.6 (1.6) | 0.8 (1.2) | 50.6 (17)*                                         |
| 1.0             | 0.15                  | ≤3                 | 2.3 (1.7)                                         | 1.8 (1.6) | 0.7 (1.2) | 63.2 (15)*                                         |
|                 |                       | ≥4                 | 0.1 (0.3)                                         | 0.1 (0.3) | 0.1 (0.2) | 50.4 (3) <sup>b</sup>                              |
|                 |                       | All                | 2.4 (1.7)                                         | 1.9 (1.7) | 0.7 (1.2) | 62.5 (16)*                                         |
|                 | 0.30                  | ≤3                 | 1.5 (1.8)                                         | 1.9 (1.8) | 1.3 (1.5) | 31.3 (19)                                          |
|                 |                       | ≥4                 | 0.5 (0.9)                                         | 0.5 (0.7) | 0.2 (0.4) | 68.9 (12)                                          |
|                 |                       | All                | 2.1 (2.2)                                         | 2.4 (2.2) | 1.4 (1.7) | 39.4 (19)*                                         |

<sup>a</sup> "C-T Percent Difference" is calculated as [(control density minus test density) divided by control density]. Thus, positive values indicate lower densities in test samples.

<sup>b</sup> Insufficient data for meaningful comparison.

\*Statistically significant difference between test and control samples (p<0.05) as determined by the Wilcoxon matched pairs test of log-transformed densities.

**Table 5-19**

**Mean density and standard deviation (SD) of striped blenny larvae collected at the Chesapeake Bay site in ambient, control, and test samples during trials with 0.5 and 1.0 mm screens at slot velocities of 0.15 and 0.30 m/sec (EPRI 2006b). C-T is the percent difference between test and control densities.**

| Slot Width (mm) | Slot Velocity (m/sec) | Larval Length (mm) | Mean Number Entrained per 100 m <sup>3</sup> (SD) |           |           | C-T Percent Difference <sup>a</sup> (Valid Trials) |
|-----------------|-----------------------|--------------------|---------------------------------------------------|-----------|-----------|----------------------------------------------------|
|                 |                       |                    | Ambient                                           | Control   | Test      |                                                    |
| 0.5             | 0.15                  | ≤3                 | 0.8 (2.1)                                         | 0.9 (1.5) | 0.1 (0.3) | 90.0 (9)*                                          |
|                 |                       | ≥4                 | 1 (1.4)                                           | 1 (1.8)   | 0.2 (0.7) | 78.8 (9)                                           |
|                 |                       | All                | 1.8 (2.5)                                         | 1.9 (2.5) | 0.3 (0.8) | 84.2 (12)*                                         |
|                 | 0.30                  | ≤3                 | 0.3 (0.5)                                         | 0.8 (1.1) | 0.5 (0.6) | 39.2 (15)                                          |
|                 |                       | ≥4                 | 3.1 (3.5)                                         | 1.5 (1.5) | 0.4 (0.7) | 72.8 (15)*                                         |
|                 |                       | All                | 3.4 (3.4)                                         | 2.3 (1.9) | 0.9 (1)   | 61.7 (17)*                                         |
| 1.0             | 0.15                  | ≤3                 | 1.1 (2.2)                                         | 1 (1.5)   | 0.6 (1)   | 35.4 (12)                                          |
|                 |                       | ≥4                 | 1.4 (2.2)                                         | 0.6 (1)   | 0.2 (0.6) | 58.3 (8)                                           |
|                 |                       | All                | 2.5 (2.8)                                         | 1.6 (1.9) | 0.9 (1.2) | 44.1 (13)                                          |
|                 | 0.30                  | ≤3                 | 1.1 (1.9)                                         | 1.1 (1.7) | 0.6 (1)   | 48.0 (12)                                          |
|                 |                       | ≥4                 | 1.3 (1.7)                                         | 0.8 (2)   | 0.4 (0.8) | 48.5 (11)                                          |
|                 |                       | All                | 2.4 (3.2)                                         | 1.9 (2.9) | 1 (1.6)   | 48.2 (14)*                                         |

<sup>a</sup> "C-T Percent Difference" is calculated as [(control density minus test density) divided by control density]. Thus, positive values indicate lower densities in test samples.

\*Statistically significant difference between test and control samples (p<0.05) as determined by the Wilcoxon matched pairs test of log-transformed densities.

**Table 5-20**

**Mean density and standard deviation (SD) of Northern pipefish larvae collected at the Chesapeake Bay site in ambient, control, and test samples during trials with 0.5 and 1.0 mm screens at slot velocities of 0.15 and 0.30 m/sec (EPRI 2006b). C-T is the percent difference between test and control densities.**

| Slot Width (mm) | Slot Velocity (m/sec) | Larval Length (mm) | Mean Number Entrained per 100 m <sup>3</sup> (SD) |           |           | C-T Percent Difference <sup>a</sup> (Valid Trials) |
|-----------------|-----------------------|--------------------|---------------------------------------------------|-----------|-----------|----------------------------------------------------|
|                 |                       |                    | Ambient                                           | Control   | Test      |                                                    |
| 0.5             | 0.15                  | ≤11                | 0.7 (0.8)                                         | 1.1 (1.8) | 0.3 (0.5) | 75.5 (12)*                                         |
|                 |                       | 12-13              | 1 (2.7)                                           | 0.6 (0.9) | 0.2 (0.7) | 75.2 (8)*                                          |
|                 |                       | ≥14                | 0.9 (1.3)                                         | 0.6 (1.7) | 0 (0)     | 100.0 (5) <sup>b</sup>                             |
|                 |                       | All                | 2.6 (2.7)                                         | 2.3 (2.5) | 0.4 (0.8) | 81.5 (17)*                                         |
|                 | 0.30                  | ≤11                | 0.4 (0.7)                                         | 1.2 (1.2) | 0.5 (0.8) | 62.0 (16)*                                         |
|                 |                       | 12-13              | 1.4 (1.5)                                         | 0.7 (0.9) | 0 (0.2)   | 92.9 (14)*                                         |
|                 |                       | ≥14                | 2.1 (2)                                           | 0.6 (1.1) | 0 (0)     | 100.0 (8)*                                         |
|                 |                       | All                | 3.9 (3.3)                                         | 2.5 (2.3) | 0.5 (0.8) | 79.4 (20)*                                         |
| 1.0             | 0.15                  | ≤11                | 0.4 (0.7)                                         | 0.7 (1)   | 0.2 (0.4) | 71.0 (9)                                           |
|                 |                       | 12-13              | 0.4 (0.5)                                         | 0.4 (0.6) | 0.2 (0.4) | 56.5 (8)                                           |
|                 |                       | ≥14                | 0.7 (0.8)                                         | 0.1 (0.4) | 0 (0.2)   | 67.9 (4) <sup>b</sup>                              |
|                 |                       | All                | 1.5 (1.1)                                         | 1.2 (1.1) | 0.4 (0.6) | 66.4 (15)*                                         |
|                 | 0.30                  | ≤11                | 0.9 (1.3)                                         | 0.4 (0.5) | 0.2 (0.4) | 51.1 (12)                                          |
|                 |                       | 12-13              | 0.8 (0.9)                                         | 0.2 (0.6) | 0.2 (0.4) | -5.7 (7)                                           |
|                 |                       | ≥14                | 0.2 (0.4)                                         | 0.5 (1.1) | 0.1 (0.3) | 79.0 (8)                                           |
|                 |                       | All                | 2 (1.6)                                           | 1.1 (1.7) | 0.5 (0.8) | 52.8 (17)                                          |

<sup>a</sup>“C-T Percent Difference” is calculated as [(control density minus test density) divided by control density]. Thus, positive values indicate lower densities in test samples.

<sup>b</sup> Insufficient data for meaningful comparison \*Statistically significant difference between test and control samples ( $p < 0.05$ ) as determined by the Wilcoxon matched pairs test of log-transformed densities.

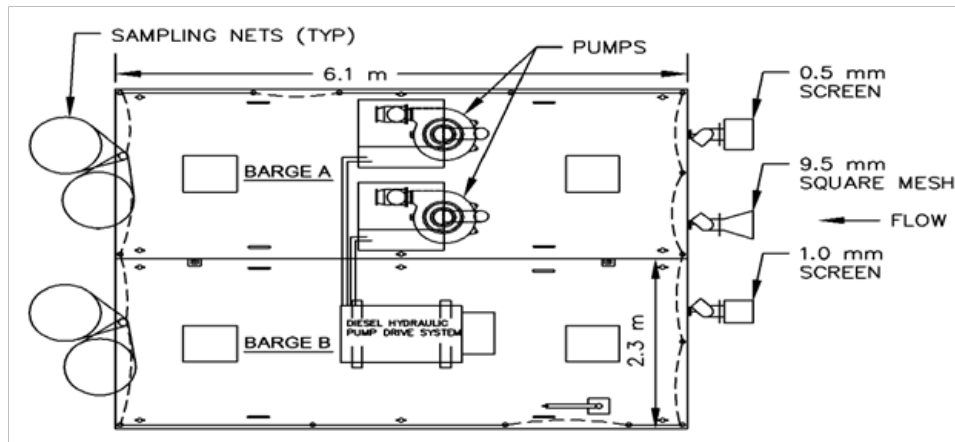
**Field Evaluation - Haverstraw Bay, Hudson River, New York**

A multi-season efficacy study of a small scale 2.0-mm (0.08-in.) slot cylindrical wedgewire screen unit for reducing entrainment of fish larvae was conducted in Haverstraw Bay on the Hudson River (AKRF, Inc. 2010, Alden 2010). The goal of this study was to determine the average efficacy (exclusion potential) of the small scale unit for entrainment compared to an open pipe. The study was conducted during August 2009 and during March, June, and July 2010, lasting 2 to 5 days per month. Target species were larval stage of bay anchovy (*Anchoa*

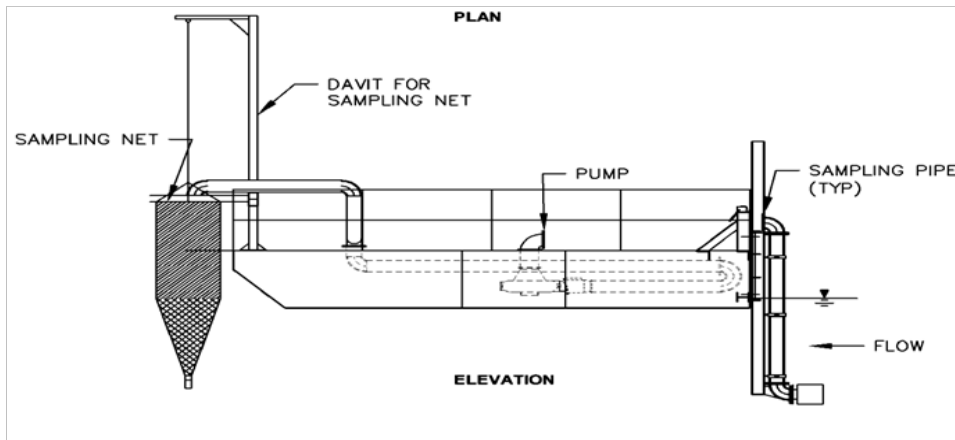


*michilli*) in August 2009, Atlantic tomcod (*Microgadus tomcod*) in March 2010, striped bass (*Morone saxatilis*) in June 2010, and striped bass and bay anchovy in July 2010.

Paired samples were collected from a floating test barge, which consisted of two separate aluminum sections (2.3 by 6.1 m [7.5 by 20 ft]) pinned together to make a 4.6 by 6.1 m (15 by 20 ft) test platform (Figure 5-13). The starboard side intake was capped with a stainless steel T-12 (30.5 cm [12 in.] diameter) 2.0-mm (0.08-in.) slot width wedgewire screen supplied by Johnson Screen (Figure 5-15). A flow distributor was located nearer the center of the screen was used to achieve an average through-slot velocity of 0.15 m/sec (0.5 ft/sec) across the screen face. The control intake was conical-shaped (flaring outward), constructed of aluminum, and capped with a 9.5-mm (.37-in.) mesh screen to prohibit entrainment of large debris (Figure 5-15). Its cone shape was designed such that through-screen velocity would approximate the test screen. Two fish pumps located within the hull of the barge withdrew approximately 100 m<sup>3</sup> (3531.5 ft<sup>3</sup>) samples, over a duration of approximately 90 min per sample (Figure 5-14).



**Figure 5-13**  
Floating test facility (barge) – plan view (Alden 2010)



**Figure 5-14**  
Floating test facility (barge) – elevation view (Alden 2010)



**Figure 5-15**  
Photographs showing the aluminum sleeve used to decrease the open area of the 2.0-mm wedgewire screen (left) and the geometry of the control intake cone (Alden 2010).

Sampling was designed to sample through several tidal cycles and to encompass several diel periods. Sample pairs consisted of control (open pipe) and treatment (wedgewire unit) and were sampled concurrently. Samples were concentrated, preserved, and shipped to an outside laboratory for processing.



**Figure 5-16**  
Floating test facility (barge) with alternative sampling equipment. Left image show intake side of barge and right image shows discharge side of barge (Alden 2010).



**Figure 5-17**  
**Floating test facility (barge with standard sampling equipment) (Alden 2010)**

The average reduction percentages were calculated in terms of angles (arc tangent) prior to averaging in order to reduce unintended biases (AKRF 2010). Reduction of entrainment of the wedgewire unit compared to the open pipe ranged from 8.5% for naked goby (*Gobiosoma bosc*) Post yolk-sac larvae (PYSL) in June 2010 to 65.6% for naked goby PYSL in August 2009 (Table 5-21). Of the 13 combinations of species, life-stage, and sampling period, seven were significantly different than an estimated 0% reduction.

**Table 5-21**

**Summary of numbers of larvae collected through open pipe and wedgewire screen unit and estimates of average reduction in entrainment densities due to wedgewire screen unit, in comparison to open pipe. Shaded areas indicate estimates that are statistically significant, based on confidence limits not overlapping a reduction of 0% (AKRF 2010).**

| Species           | Life Stage | Sampling Period | Number of Paired Samples Containing Species and Life Stage | Average Length of Larvae (mm) |            | Numbers of Organisms Collected |            | Average Reduction in Entrainment Densities (%) |                      |            |
|-------------------|------------|-----------------|------------------------------------------------------------|-------------------------------|------------|--------------------------------|------------|------------------------------------------------|----------------------|------------|
|                   |            |                 |                                                            | Open Pipe                     | Wedge-wire | Open Pipe                      | Wedge-wire | Estimate                                       | Confidence Intervals |            |
|                   |            |                 |                                                            |                               |            |                                |            |                                                | Lower 95 %           | Upper 95 % |
| <i>Alosa</i> spp. | PYSL       | Jun-10          | 20                                                         | 6.2                           | 5.3        | 79                             | 45         | 28.3                                           | -26.6                | 64.4       |
| Atlantic tomcod   | PYSL       | Mar-10          | 10                                                         | 7.9                           | 8          | 128                            | 96         | 26.6                                           | -22.2                | 60.0       |
| bay anchovy       | Eggs       | Jun-10          | 24                                                         | --                            | --         | 698                            | 717        | 18.9                                           | -21.6                | 47.9       |
|                   | Eggs       | Jul-10          | 18                                                         | --                            | --         | 4,488                          | 4,481      | 9.6                                            | -18.5                | 31.5       |
|                   | PYSL       | Aug-09          | 33                                                         | 7.5                           | 8.2        | 635                            | 274        | 62.3                                           | 43.5                 | 79.1       |
|                   | PYSL       | Jun-10          | 24                                                         | 4.4                           | 4.6        | 1,133                          | 842        | 39.5                                           | 18.2                 | 57.5       |
|                   | PYSL       | Jul-10          | 18                                                         | 5.1                           | 5.4        | 1,246                          | 568        | 38.4                                           | 4.7                  | 64.3       |
| naked goby        | PYSL       | Aug-09          | 22                                                         | 5.6                           | 5.9        | 107                            | 34         | 65.6                                           | 41.6                 | 86.5       |
|                   | PYSL       | Jun-10          | 18                                                         | 3.7                           | 3.8        | 54                             | 39         | 8.5                                            | -66.3                | 51.4       |
|                   | PYSL       | Jul-10          | 13                                                         | 4.4                           | 5.6        | 162                            | 128        | 48.8                                           | 17.5                 | 73.8       |
| striped bass      | YSL        | Jun-10          | 18                                                         | 6.6                           | 6.1        | 460                            | 383        | 42.5                                           | -4.3                 | 75.8       |
|                   | PYSL       | Jun-10          | 15                                                         | 6.7                           | 8.0        | 689                            | 27         | 52.6                                           | 4.3                  | 87.7       |
| hogchoker         | PYSL       | Jul-10          | 15                                                         | 2.6                           | 2.9        | 54                             | 14         | 57.8                                           | 16.0                 | 90.0       |

Highlighted fields indicate significantly different reduction than an estimated 0% reduction.

A sensitivity analysis determined weighted reduction averages for each collected pair based off of total number of fish collected in the sample. These results showed to be similar to the averages not weighted in terms of being significantly different or similar to an estimate of 0% reduction (Table 5-22). The disparities between the two analyses were Atlantic tomcod (*Microgadus tomcod*) PYSL in March 2010, bay anchovy (*Anchoa mitchilli*) June 2010, and naked goby PYSL in July 2010.

**Table 5-22**

**Summary of numbers of larvae collected through open pipe and wedgewire screen unit and estimates of average reduction in entrainment densities due to wedgewire screen unit, in comparison to open pipe. Shaded areas indicate estimates that are statistically significant, based on confidence limits not overlapping a reduction of 0% (AKRF 2010).**

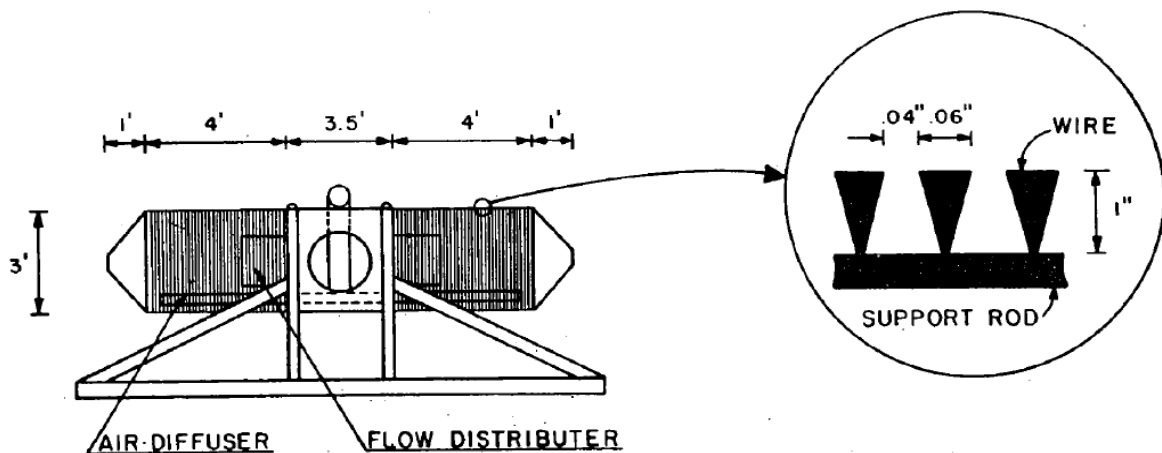
| Species           | Life Stage | Sampling Period | Number of Paired Samples Containing Species and Life Stage | Average Length of Larvae (mm) |            | Numbers of Organisms Collected |            | Weighted Average Reduction in Entrainment Densities (%) |                      |            |
|-------------------|------------|-----------------|------------------------------------------------------------|-------------------------------|------------|--------------------------------|------------|---------------------------------------------------------|----------------------|------------|
|                   |            |                 |                                                            | Open Pipe                     | Wedge-wire | Open Pipe                      | Wedge-wire | Estimate                                                | Confidence Intervals |            |
|                   |            |                 |                                                            |                               |            |                                |            |                                                         | Lower 95 %           | Upper 95 % |
| <i>Alosa</i> spp. | PYSL       | Jun-10          | 20                                                         | 6.2                           | 5.3        | 79                             | 45         | 38.7                                                    | -7.8                 | 71.6       |
| Atlantic tomcod   | PYSL       | Mar-10          | 10                                                         | 7.9                           | 8          | 128                            | 96         | 22.6                                                    | 0.7                  | 40.7       |
| bay anchovy       | Eggs       | Jun-10          | 24                                                         | --                            | --         | 698                            | 717        | -3.4                                                    | -29.2                | 17.1       |
|                   | Eggs       | Jul-10          | 18                                                         | --                            | --         | 4,488                          | 4,481      | 2.7                                                     | -11.0                | 14.8       |
|                   | PYSL       | Aug-09          | 33                                                         | 7.5                           | 8.2        | 635                            | 274        | 53.8                                                    | 35.4                 | 70.0       |
|                   | PYSL       | Jun-10          | 24                                                         | 4.4                           | 4.6        | 1,133                          | 842        | 23.8                                                    | -3.7                 | 45.5       |
|                   | PYSL       | Jul-10          | 18                                                         | 5.1                           | 5.4        | 1,246                          | 568        | 52.4                                                    | 35.9                 | 67.0       |
| naked goby        | PYSL       | Aug-09          | 22                                                         | 5.6                           | 5.9        | 107                            | 34         | 66.0                                                    | 48.0                 | 82.1       |
|                   | PYSL       | Jun-10          | 18                                                         | 3.7                           | 3.8        | 54                             | 39         | 25.4                                                    | -15.4                | 54.8       |
|                   | PYSL       | Jul-10          | 13                                                         | 4.4                           | 5.6        | 162                            | 128        | 17.5                                                    | -23.4                | 46.7       |
| striped bass      | YSL        | Jun-10          | 18                                                         | 6.6                           | 6.1        | 460                            | 383        | 7.2                                                     | -76.7                | 52.9       |
|                   | PYSL       | Jun-10          | 15                                                         | 6.7                           | 8.0        | 689                            | 27         | 95.2                                                    | 83.7                 | 106.5      |
| hogchoker         | PYSL       | Jul-10          | 15                                                         | 2.6                           | 2.9        | 54                             | 14         | 67.8                                                    | 34.8                 | 95.4       |

Highlighted fields indicate significantly different reduction than an estimated 0% reduction.

## Field Evaluation – Mississippi River, Mississippi

A study was conducted to determine the effectiveness of a remote wedgewire screen intake module at reducing the numbers of entrained fish eggs and larvae compared to field densities on the Mississippi River (Otto et al. 1981). The screen was T-shaped with 1.0-mm (0.04-in) slot stainless steel and was 4.1 m (13.45 ft) in length, and 0.9 m (2.95 ft) in diameter (Figure 5-18). Sampling occurred between May 24 and June 28 1979 in a side channel on the east side of Pool 13 of the Mississippi River at approximately River mile 530. The screen module was situated at the center of the side channel, where river velocities ranged from 0.37 to 0.81 m/sec (1.21 to 2.66 ft/sec) during testing. Sampling events consisted of day and night samples collected over a continuous 24-hour sampling period.

Samples were collected through the screen module using a propeller like irrigation pump at a maximum rate of 0.25 to 0.28 m<sup>3</sup>/sec (9 to 10 cfs). Downstream of the pump, samples were collected in a flow reduction trough, designed to screen large amounts of water with minimum detrimental effects to screened organisms. Sampling volume ranged from 25 to 75 m<sup>3</sup> (882.87 to 2648.6 cfs). Ambient samples were collected using fixed nets mounted to anchor float arrays and tow nets deployed from a boat, both collecting at similar depths to the module. All collected samples were washed into a collected box and preserved in 10% buffered formalin containing rose bengal. Fish and eggs were then identified to the lowest possible taxon.



**Figure 5-18**  
Test module with wire design (University of Iowa, Institute of Hydraulic Research)

Entrainment results from from the wedgewire screen were well below background densities from one taxon of eggs and four of the five taxa of larvae present at the test site during the evaluation (Table 5-23). The module was effective at excluding *Clupeidae*, emerald shiner (*Notropis atherinoides*), carp (Cyprinidae), and freshwater drum (*Aplodinotus grunniens*) larvae, having an 11% or less proportion of the population only collected by the module. The module was less effective at screening crappies (*Pomoxis* spp.), entraining 25.4% of the collected population in the module. Module entrainment densities were also well below the background densities. However, the hope was that the 1.0-mm (0.04-in.) screen to totally exclude freshwater drum eggs, averaging 1.42 mm (0.55 in) in diameter. These eggs may have been more susceptible to entrainment due to a large perivitelline space, which may be deformable to a degree that would permit passage through the slots. These large perivitelline spaces were observed while egg

diameters were being measured. The diameter of eggs of other species were not measured, so it is unknown the extent to which other species exhibit large perivitelline spaces. The authors suggest that the successful reduction of entrainment for larval fish was partly due to mechanical and behavioral components. Zeitoun et al 1981 and Browne 1981 also suggest a negative rheotrophic response to the nearfield velocity regime adjacent to the intake orifice.

**Table 5-23**  
**Relative catches of larvae (Otto et al. 1981)**

| Species              | Entrainment %<br>by Module | Entrainment %<br>by Fixed Net | Entrainment %<br>by Tow Net |
|----------------------|----------------------------|-------------------------------|-----------------------------|
| <i>Clupeidae</i>     | 7                          | 47.5                          | 45.5                        |
| emerald shiner       | 10.5                       | 48.2                          | 41.3                        |
| carp                 | 7.5                        | 40.3                          | 52.2                        |
| freshwater drum      | 4.4                        | 50                            | 45.6                        |
| freshwater drum eggs | 10.5                       | 52.2                          | 38.3                        |
| crappies             | 25.4                       | 35.2                          | 39.4                        |

***Field Evaluation – Marin Municipal Water District Desalination (MMWD) Pilot Plant***

A 12-month sampling effort was conducted to quantify potential entrainment impacts of the narrow slot intake screens installed at Marin Municipal Water District Desalination (MMWD) Pilot Plant, San Rafael, California (Tenera 2007). The MMWD water intake consisted of a cylindrical narrow-slot intake screen (2.4-mm [0.09-in.] slot width) (Figure 5-19), an intake and priming pump, intake piping, and seawater holding tank. The intake withdrew water from the San Pablo Bay from approximately 609.6 m (2,000 ft) offshore at approximately 473 lpm (125 gpm).





**Figure 5-19**  
**MMWD pilot plant cylindrical narrow slot intake**

Entrainment samples were collected at the pilot plant intake. Sampling was collected bi-weekly from July 8, 2005 – June 21, 2006. Surveys were 8 hrs long, scheduled for equal amounts of day and night conditions. Sixteen, 30-min collections were made during each 8-hr survey. Water was pumped from the screen intake through 365.8 m (1,200 ft) of 10.2-cm (4-in) diameter pipe into the intake holding tank. Plankton nets with 363- $\mu\text{m}$  mesh were deployed in the holding tanks during sampling. After sampling was completed, the contents of the net were rinsed into the codend and collected for identification.

Source water sampling was conducted from February – March 2006, concurrently with entrainment sampling. Hydraulic data from U.S. Geological Services (USGS) and biological data from California Department of Fish and Game (CDFG) provided basis for selecting locations. A small boat equipped with a sampling apparatus consisting of two 0.31-m (1-ft) diameter, 363- $\mu\text{m}$  mesh conical plankton nets was used to collect samples. Each collection sampled an average volume of approximately 28 m<sup>3</sup> (988.8 ft<sup>3</sup>). Once the collection was completed, contents of both nets were rinsed from the nets and combined into one codend. Organisms collected during both sampling efforts were identified to the lowest possible taxon, measured (notochord length for up to 200 individuals per species), and enumerated.

A total of 28,001 entrainable size fish and 2,185 fish eggs were collected during entrainment sampling. A total of 65,662 entrainable size fish and 127 fish eggs were collected during source water sampling (Table 5-24). Pacific herring (*Clupea pallasii*) comprised 98% of both samples. Empirical transport modeling (ETM) estimates the probability of mortality due to entrainment ranged from 0.02 to 0.06%. The study authors concluded that a full scale desalination facility (113.6 MLD [30 MGD]) would be low risk to the ambient fish populations.

**Table 5-24**  
**Numbers of larval fishes and fish eggs during entrainment and source water sampling at Marin Municipal Water District Desalination (MMWD) pilot plant**

| <b>Entrainable Larval Fishes:</b>     |                          |                           |                     |
|---------------------------------------|--------------------------|---------------------------|---------------------|
| <b>Taxon</b>                          | <b>Common name</b>       | <b>Total Sample Count</b> |                     |
|                                       |                          | <b>Entrainment</b>        | <b>Source water</b> |
| <i>Clupea pallasii</i>                | Pacific herring          | 27,490                    | 64,448              |
| Gobiidae unid.                        | gobies                   | 225                       | 640                 |
| unid. Larval fish damaged             | unid. larval fishes      | 92                        | 5                   |
| <i>Engraulis mordax</i>               | Northern anchovy         | 81                        | --                  |
| <i>Acanthogobius flavimanus</i>       | yellowfin goby           | 68                        | 436                 |
| Osmeridae unid.                       | smelts                   | 10                        | 62                  |
| <i>Cottus asper</i>                   | prickly sculpin          | 8                         | 21                  |
| <i>Lepocottus armatus</i>             | Pacific staghorn sculpin | 8                         | 13                  |
| Cottidae unid.                        | sculpins                 | 3                         | 1                   |
| <i>Lepidogobius lepidus</i>           | bay goby                 | 4                         | 2                   |
| <i>Hypsopsetta guttulatta</i>         | diamond turbot           | 3                         | --                  |
| larval/post-larval fish unid.         | larval fishes            | 3                         | --                  |
| <i>Genyonemus lineatus</i>            | white croaker            | 2                         | 14                  |
| Atherinopsidae unid.                  | silversides              | 1                         | --                  |
| <i>Cebidichthys violaceus</i>         | monkeyface eel           | 1                         | 3                   |
| <i>Platichthys stellatus</i>          | starry flounder          | 1                         | --                  |
| <i>Sebastes</i> spp.                  | rockfishes               | 1                         | 3                   |
| <i>Psettichthys melanostictus</i>     | sand sole                | --                        | 5                   |
| <i>Paralichthys californicus</i>      | California halibut       | --                        | 3                   |
| <i>Ammodytes hexapterus</i>           | Pacific sand lance       | --                        | 1                   |
| <i>Artedius</i> spp.                  | sculpins                 | --                        | 1                   |
| Bathymasteridae unid.                 | ronquils                 | --                        | 1                   |
| <i>Parophrys vetulus</i>              | English sole             | --                        | 1                   |
| <i>Pleuronectidae</i> unid.           | flounders                | --                        | 1                   |
| <i>Sygnathus</i> spp.                 | pipefishes               | --                        | 1                   |
| <b>Total Entrainable Fishes:</b>      |                          | <b>28,001</b>             | <b>65,662</b>       |
| <b>Non-Entrainable Larval Fishes:</b> |                          |                           |                     |
| Gobiidae unid.                        | gobies                   | 1                         | --                  |
| <i>Lepidogobius lepidus</i>           | bay goby                 | --                        | 1                   |
| <b>Total Non-Entrainable Fishes:</b>  |                          | <b>1</b>                  | <b>1</b>            |
| <b>Fish Eggs:</b>                     |                          |                           |                     |
| non-engraulidae eggs                  | eggs, unidentified       | 1,558                     | 126                 |
| Engraulidae eggs                      | anchovy eggs             | 626                       | 1                   |
| Atherinopsidae unid. eggs             | silverside eggs          | 1                         | --                  |
| <b>Total Eggs:</b>                    |                          | <b>2,185</b>              | <b>127</b>          |
| <b>Invertebrates:</b>                 |                          |                           |                     |
| <i>Crangon nigricauda</i>             | black-tailed bay shrimp  | 17                        | --                  |
| <i>Crangon</i> spp. (zoea I)          | bay shrimp               | 3                         | --                  |
| <b>Total Invertebrates:</b>           |                          | <b>20</b>                 | <b>0</b>            |

# 6

## BARRIER NETS

### Introduction

Barrier nets have been effectively applied at several power plant cooling water systems as well as a number of hydroelectric projects and other water intakes. The ability of barrier nets to exclude fish from a water intake depends on the fish species and size to be protected, near-field hydraulic conditions, and the amount of debris present. The mesh size must be selected to block fish passage but not cause fish to become gilled in the net. Debris cleaning and biofouling control can be labor-intensive. Further consideration should be given to the effects of the net's location on navigation within the source waterbody.

In 2006, EPRI produced a comprehensive report on the use of barrier nets to reduce fish impingement at CWIS (EPRI 2006c). That report presented a review of existing fish barrier net installations and design considerations and specifications for new installations at CWIS. Also presented was guidance to plant operators, managers, and engineers in the planning and designing of fish barrier nets, including three different barrier net support designs<sup>0</sup>

Barrier nets can be considered a viable option for protecting fish provided that reasonable hydraulic conditions can be achieved and debris loading is light. A thorough evaluation of site-specific environmental and operational conditions is generally necessary to determine whether a barrier net might be applicable to a given site. New information on the operation and maintenance of nets will become available in the future as effectiveness evaluations are performed on newly installed nets.

Existing barrier net installations for power plant cooling water intakes and hydroelectric plant intakes were reviewed and are listed in Table 6-1 and Table 6-2, respectively.

**Table 6-1**  
**Existing barrier net installations, power plants/diversion field tests**

| <b>Parameter</b>           | <b>Bowline Generating Station</b> | <b>Chalk Point</b>     | <b>Dallman</b>                    | <b>J. P. Pulliam</b>         | <b>Laskin</b>              | <b>Arkansas Nuclear One</b> | <b>LaSalle County Generating Station</b> | <b>Pickering Nuclear Generation Station</b> | <b>Osage Power Plant at Bagnel Dam</b> |
|----------------------------|-----------------------------------|------------------------|-----------------------------------|------------------------------|----------------------------|-----------------------------|------------------------------------------|---------------------------------------------|----------------------------------------|
| Owner                      | Mirant Bowline, LLC               | Mirant MidAtlantic     | City Water and Light              | Wisconsin Public Service     | Minnesota Power & Light    | Entergy                     | Exelon Corp                              | Ontario Power Generation                    | Ameren                                 |
| Waterbody                  | Hudson River/Bowline Pond         | Patuxent River         | Lake Springfield                  | Lake Michigan, via Fox River | Colby Lake/Partridge River | Dardanelle Reservoir        | Cooling Pond                             | Lake Ontario                                | Lake of the Ozarks                     |
| Flow Capacity (cfs)        | 1,408                             | 1,060                  | ~920                              | 805                          | 223                        | 1,323                       | 2,890                                    | 8,970                                       | unknown                                |
| Max Water Depth (ft)       | 39                                | 25                     | N/A                               | 14                           | 16                         | 20                          | 20                                       | 8.5-13.5                                    | 100                                    |
| Net Length (ft)            | 597                               | 533 inner<br>671 outer | N/A                               | 112                          | 600                        | 1,500                       | 1,200                                    | 2,000                                       | 850                                    |
| Approach Velocity (ft/s)   | < 0.5                             | 0.13                   | 0.4<br>(proposed net)             | <0.5                         | 0.08                       | 0.04                        | 0.1                                      | unknown                                     | 1.0                                    |
| Bar Mesh (in) <sup>1</sup> | 0.10/0.20                         | 0.75/1.25              | 0.5 (existing)<br>0.38 (proposed) | 0.25                         | 0.25                       | 0.5 & 0.38                  | 0.38                                     | 0.5x0.5                                     | 2                                      |

| Parameter                    | Bowline Generating Station                                                                    | Chalk Point                     | Dallman                       | J. P. Pulliam                               | Laskin                        | Arkansas Nuclear One             | LaSalle County Generating Station      | Pickering Nuclear Generation Station                                                                              | Osage Power Plant at Bagnel Dam                                                                                               |
|------------------------------|-----------------------------------------------------------------------------------------------|---------------------------------|-------------------------------|---------------------------------------------|-------------------------------|----------------------------------|----------------------------------------|-------------------------------------------------------------------------------------------------------------------|-------------------------------------------------------------------------------------------------------------------------------|
| Net Material                 | knotted nylon                                                                                 | N/A                             | nylon (proposed)              | knotless nylon                              | nylon                         | N/A                              | Polyethylene                           | Dyneema                                                                                                           | Dyneema                                                                                                                       |
| Species Protected/ Evaluated | bay anchovy<br>striped bass<br>white perch<br>American shad<br>alewife<br>blueback<br>herring | misc. finfish<br>crabs          | gizzard shad<br>white crappie | alewife<br>yellow perch                     | black crappie<br>yellow perch | N/A                              | gizzard shad                           | alewife,<br>emerald shiner, rainbow smelt,<br>threespine stickleback,<br>brown bullhead,<br>walleye, yellow perch | paddlefish,<br>centrarchids,<br>moronids,<br>catostomids,<br>cyprinids,<br>ictalurids,<br>sciaenids,<br>clupeids,<br>perceids |
| Effectiveness                | ~ 91% reduction from 1977 - 1985                                                              | 84% reduction in crab mortality | 96% impingement reduction     | 85 - 98% impingement reduction              | N/A                           | N/A                              | N/A                                    | unknown                                                                                                           | 84-97% large fish mortality reduction and 92.2% entrainment reduction                                                         |
| Net Manufacturer             | N/A                                                                                           | American Net or Memphis Net     | N/A                           | FNT Industries, Inc. of Menominee, Michigan | Sterling Net and Twine        | Mid Lakes Corps, Knoxville Tenn. | Delta Net and Twine, Greenville, Miss. | unknown                                                                                                           | unknown                                                                                                                       |

1. Bar mesh is the length between two knots measured from the inside of one knot to the outside of the second knot. Stretch mesh is the inside diagonal distance between two knots on opposite sides of the stretched square mesh.

**Table 6-2**  
**Existing barrier net installations, hydroelectric/diversion field tests**

| Parameter                | Pine Hydroelectric Project <sup>2</sup> | Brule Hydroelectric Project | Hayward Hydroelectric Project <sup>1</sup> | Ludington Pump Storage Project              | Baker River Hydroelectric Project | Puntledge Hydroelectric Project | Crystal Falls Hydroelectric Project | Banks Lake <sup>1</sup>  | Highline <sup>1</sup>    |
|--------------------------|-----------------------------------------|-----------------------------|--------------------------------------------|---------------------------------------------|-----------------------------------|---------------------------------|-------------------------------------|--------------------------|--------------------------|
| Owner                    | WE Energies                             | WE Energies                 | Xcel Energy                                | Consumers Energy Company and Detroit Edison | Puget Sound Energy                | BC Hydro                        | City of Crystal Falls               | US Bureau of Reclamation | Highline Lake State Park |
| Waterbody                | Pine River                              | Brule River                 | Namekagon River                            | Lake Michigan                               | Baker River                       | Puntledge River                 | Paint River                         | Banks Lake               | Highline Lake            |
| Flow Capacity (cfs)      | 640                                     | 1,377                       | 180                                        | 66,000                                      | 4,100                             | 1,060                           | N/A                                 | 7,910                    | ~2,000                   |
| Max Water Depth (ft)     | 35                                      | 30                          | 10                                         | 45                                          | 285                               | 25                              | 20                                  | 79                       | 19                       |
| Net Length (ft)          | 260                                     | 217                         | 75                                         | 12,850                                      | 1,520                             | 141                             | 100                                 | 4,400                    | 363                      |
| Approach Velocity (ft/s) | 0.1 to 0.5                              | 0.2                         | < 0.5                                      | < 2.5                                       | 0.01                              | 0.4-1.7                         | N/A                                 | 1.6                      | <0.3                     |
| Bar Mesh (in)            | 0.5                                     | 0.38/0.50                   | 0.38                                       | 0.75/0.50                                   | 0.25                              | 0.75                            | 0.5                                 | 3.25                     | 0.25                     |
| Net Material             | knotted nylon                           | knotless nylon              | knotted nylon                              | Dyneema                                     | nylon                             | knotless nylon                  | knotted nylon                       | knotless Dacron          | Dyneema                  |

| Parameter                    | Pine Hydroelectric Project <sup>2</sup>                   | Brule Hydroelectric Project | Hayward Hydroelectric Project <sup>1</sup> | Ludington Pump Storage Project                                 | Baker River Hydroelectric Project | Puntledge Hydroelectric Project        | Crystal Falls Hydroelectric Project | Banks Lake <sup>1</sup>               | Highline <sup>1</sup>                     |
|------------------------------|-----------------------------------------------------------|-----------------------------|--------------------------------------------|----------------------------------------------------------------|-----------------------------------|----------------------------------------|-------------------------------------|---------------------------------------|-------------------------------------------|
| Species Protected/ Evaluated | large mouth bass, bluegill, channel catfish, white sucker | centrarchids percids        | walleye                                    | rainbow smelt<br>alewife<br>yellow perch<br>salmonids          | sockeye<br>coho                   | coho salmon                            | N/A                                 | Kokanee                               | lg. mouth bass<br>bluegill ch.<br>catfish |
| Effectiveness                | 85% to 99% effective                                      | ~ 50%                       | N/A                                        | 92.1% target fish effective<br>85.1% non-target fish effective | N/A                               | 99.3% effective during test evaluation | N/A                                 | from 64% to 10% entrainment reduction | N/A                                       |
| Net Manufacturer             | N/A                                                       | N/A                         | N/A                                        | Pacific Netting/Redden Marine                                  | Redden Marine                     | N/A                                    | N/A                                 | N/A                                   | Redden Marine                             |

1. Banks Lake and Highline CWISs are irrigation facilities.

2. Pine Hydroelectric is entraining what would be considered impingeable organisms at a Phase II facility. Pine Hydroelectric uses 25mm mesh (stretch).

## Case Studies – CWIS Application

### ***Dallman Generating Station, Lake Springfield, Illinois***

The city of Springfield, Illinois, City Water and Light Company (SCWLP) has had a barrier net installed in the intake canal entrance of Dallman Generating Station (Dallman) since 1981 to reduce the number of fish (gizzard shad [*Dorosoma cepedianum*] and white crappie [*Pomoxis annularis*]) and the amount of debris in the canal. The net is used to minimize fish impingement and debris accumulation on the intake screens which are located upstream of the circulating water pumps. Dallman has an intake flow of approximately 26 m<sup>3</sup>/sec (920 cfs/595 mgd). The net has a mesh size of 13 mm (0.5 in.) and is supported by a top line cable anchored at each end to shore. The bottom of the net is secured by bottom anchors. However, the bottom is not continuously anchored and occasionally gets lifted.

SCWLP has proposed the barrier net as the most appropriate compliance alternative for meeting its 316(b) requirements. The company will modify the existing barrier net to a nylon net with a mesh size of 9.5 mm (3/8 in.; 70% open area) and add a continuous chain and supplemental anchor weights to eliminate uplift of the net and avoid gaps that have developed in the past (Schimmoller 2005). Pilings will be installed on the downstream side of the net to reduce bowing under high debris loads and increase the reliability of the net remaining in contact with the bottom of the lake. The net will have a surface area of 213.7 m<sup>2</sup> (2,300 ft<sup>2</sup>). The modified net will have an approach velocity of about 0.1 m/sec (0.4 ft/sec) (Schimmoller 2005). The only biological effectiveness data found is from Schimmoller (2005) who reports a 90% reduction in impingement mortality.

Heavy loading of leaves and debris in the spring and fall require net removal for cleaning and maintenance. Algae growth in the summer causes the net openings to become plugged (Schimmoller 2005). The net was replaced in May of 2003, as shown on Figure 6-1. The old net was sent back to the manufacturer for repairs and recoating with “plastic net treatment” to minimize the potential for biogrowth (SCWLP 2004).





**Figure 6-1**  
**Dallman barrier net installation 2003**

### ***Bowline Point Generating Station, Hudson River, New York***

Bowline Point Generating Station installed a barrier net on the Hudson River in 1977. The net is located in Bowline Pond, off the main river channel and is not subjected to high river currents. The flow capacity at Bowline is  $40 \text{ m}^3/\text{s}$  (1,408 cfs/910 mgd). The net is 182 m (597 ft) long with a maximum depth of 12 m (39 ft). The net configuration at Bowline is shown on Figure 6-2. The barrier net is multifilament, knotted nylon mesh with 0.38- to 0.5-cm (0.15- to 0.2-in.) openings. The net is deployed in the winter from mid-October to mid-May to prevent impingement of white perch (*Morone americana*) and striped bass (*Morone saxatilis*). At this site, velocities are generally well below 0.1 m/sec (0.33 ft/sec).

In 1993 and 1994, Orange and Rockland Utilities, Inc. sponsored an effectiveness study of a 3.0 mm (0.1 in.), fine-mesh net at Bowline Point as a possible means to reduce fish entrainment (LMS 1994). The fine-mesh net deployment system is shown on Figure 6-3. Results of the study are provided below.

The barrier net was evaluated from 1976-1985 in the V-arrangement shown in Figure 6-2. The barrier net is deployed during periods of historically high impingement months (October-May). Impingement at Bowline is dominated by young-of-the-year and yearling white perch (75%), striped bass (15%), rainbow smelt (*Osmerus mordax*; 5%), alewife (*Alosa pseudoharengus*), blueback herring (*Alosa aestivalis*), and American shad (*Alosa sapidissima*; 1% for all clupeids). The majority of fish impinged at Bowline range from 5 to 10 mm (0.2 in. to 0.4 in.) total length. Starting in 1973, impingement samples were collected 1-3 times per week between October-May. Densities of fish impinged (number of fish/ $10^6 \text{ m}^3$ ) for comparable periods before and after net deployment (1976) were evaluated. Fish impingement for all species combined was significantly reduced (91%;  $P \leq 0.0001$ ) with the net deployed (Hutchison and Matousek 1988).

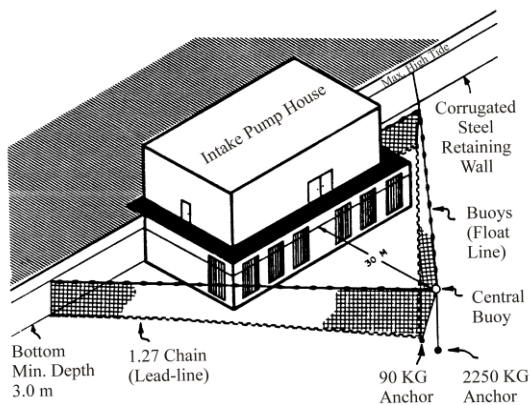
Survival probabilities were determined for white perch and striped bass released inside and outside the net. Fish movement into and out of the embayment was blocked using a barrier net across the inlet. Fish were netted, marked, and released in the inlet. Three days after the final

release, surface, midwater, and bottom trawls were used to collect fish for population estimates. In addition, impingement was monitored during the same period. Fish released inside of the net had 72% lower survival ( $P \leq 0.0001$ ) (Hutchison and Matousek 1988).

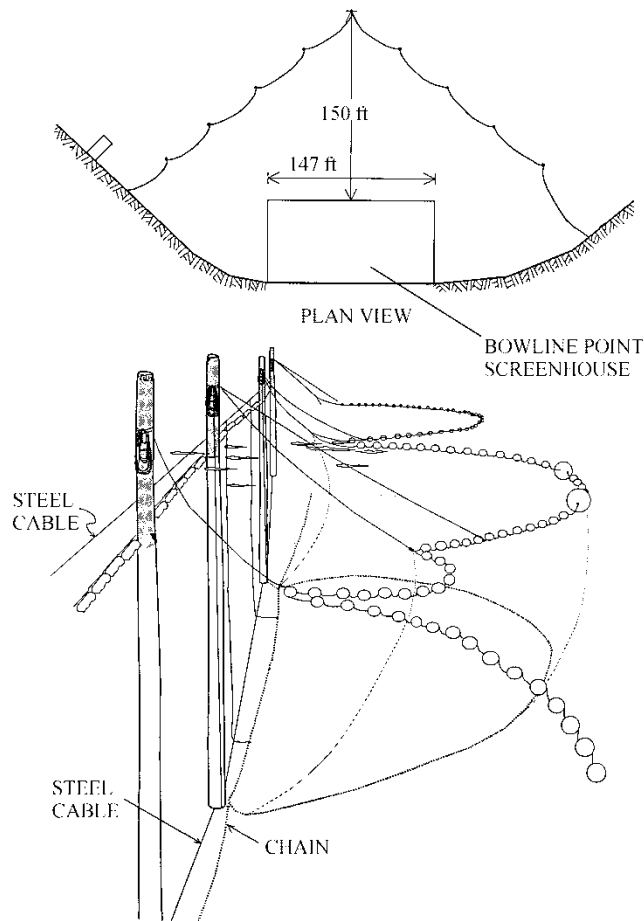
Investigation of a fine-mesh barrier net began in 1993 at Bowline. Entrainment at Bowline is dominated by bay anchovy (*Anchoa mitchilli*; >80%). A full-scale net was designed, constructed, and deployed during a 6-week test period from mid-July through August, which corresponds with the historical peak in bay anchovy post yolk-sac ichthyoplankton. The net was made of 9.5 mm nylon mesh and deployed using pilings. During the evaluation, problems with net clogging and sinking were encountered. The primary clogging agent was very fine suspended silt. Additional floatation at the surface and in situ cleaning using high pressure water sprays were used to maintain the net. Ichthyoplankton levels were too low during the evaluation to determine biological effectiveness (LMS 1994).

Additional tests were undertaken from July 12 through August 5 1994. Extensive biofouling resulted in snapping of two of the support piles. High pressure underwater sprays which had been effective in 1993 was unsuccessful in removing the algae *Ectocarpus* sp. The net was effectively cleaned by removing it from the water and applying the high pressure sprays. There were no significant differences in bay anchovy ichthyoplankton inside and outside the net during the 1994 study period (LMS 1996a).

In 1993, clogging with fine suspended silt caused the fine-mesh test net to clog and sink. Labor-intensive, high-pressure spraying by divers and additional floatation countered this problem and the net was maintained for nearly one month (LMS 1994). In 1994, spraying was not effective in cleaning the net when it became fouled by the algae *Ectocarpus*. Excessive fouling caused two of the support piles to snap, ending the evaluation (LMS 1996a). Successful cleaning of the net was achieved by removing it from the water, using the high-pressure spraywash system and then reinstalling the net.



**Figure 6-2**  
**Bowline Point barrier net configuration (LMS 1978)**



**Figure 6-3**  
**Bowline Point fine-mesh barrier net configuration (LMS 1994)**

### ***Chalk Point Station***

A temporary barrier net was installed at Chalk Point Generating Station in July 1981 in the estuarine Patuxent River (a tributary to the Chesapeake Bay) in response to operational problems caused by blockage of the condensers by blue crabs. A single permanent net was installed in 1982, and an additional net was added in 1982. The net system was used to meet the BTA requirements under Maryland's State 316(b) regulations (Bailey 2005). The original barrier net has undergone a variety of modifications over the past 20 years to improve its performance. A description of the Chalk Point intake and the barriers nets follows.

Cooling water at Chalk Point is drawn into the once-through cooling system via a 140 m (459 ft) wide 5 m (16.4 ft) deep intake canal. The intake has two units each fitted with two traveling water screens with 9.5 mm (3/8-in.) square mesh. Each unit has an intake capacity of 16 m<sup>3</sup>/s (557 cfs/360 mgd per unit or 720 mgd total).

The current outside net is designed to trap most of the debris and jellyfish, while a finer mesh net is used on the inside to exclude smaller organisms. Net support pilings are arranged in two rows measuring 162.5 and 213 m (533 and 700 ft) long at the intake canal mouth (Figure 6-4). The pilings are driven into the bottom and extend 1.5 m (5 ft) out of the water. Forty pilings make up

the inner row and fifty-one pilings comprise the outer row. They are spaced approximately 3.7 to 4.0 m (12 to 13 ft) apart, and a 6 m (20 ft) gap exists in the outer row to allow maintenance boats to enter between the nets.

The inner barrier net has eight 45.7 m (150 ft) long, 7.6 m (25 ft) deep panels suspended from hooks on the pilings approximately 0.9 m (3 ft) above the water surface at high tide. A heavy chain is attached to the bottom of the net and floats are attached to the top. The net panels overlap each other by 18.3 m (60 ft). The inner barrier net is 19.5-mm (0.75-in.) stretch mesh. A 1.2 m (4 ft) deep and 115.8 m (380 ft) long skirt was added to the system in 1984 when divers observed the net off of the bottom at numerous pilings. The skirt is attached to the pilings of the inner barrier net across the mid-channel zone. The outer barrier net is made of a series of sewn panels 61 m (200 ft) long and 7.6 m (25 ft) deep with 31.8-mm (1.25-in.) stretch mesh. The nets are manufactured by American Net or Memphis Net.

Barrier net effectiveness has been estimated using three different techniques: pre- and post-net deployment impingement monitoring; long-term relative abundance monitoring; and analytical methods (Bailey 2005; Loos 1986a, b, 1987).

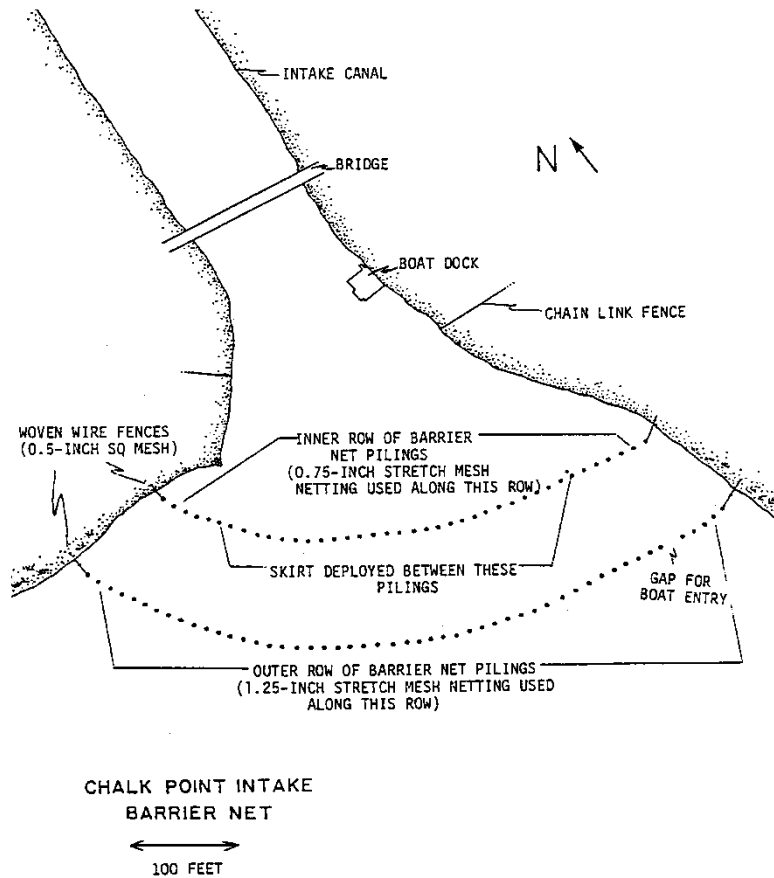
Impingement monitoring was conducted between June 1976 and November 1977 prior to net installation to estimate the numbers of fish and blue crabs impinged on the traveling screens. Following net deployment, impingement samples were collected from March 1984 to September 1985. Additional qualitative impingement sampling was conducted from June 1989 through 1999 to monitor net performance (Bailey 2005). Relative abundance data tracks changes in long-term fish and crab abundance in the area of Chalk Point based on seine and trawl sampling. Analytical methods involved adjusting impingement data to account for differences in sampling methods, plant operations, changes in population abundance, and bias imparted due to fish deterioration and crab predation in warm months.

Blue crab (*Callinectes sapidus*) were the most commonly impinged organism, making up 45.1% of the total impingement in 1976–1977 and 75.3% in 1984–1985 (38.1% using the census data in 1984–1985). Atlantic menhaden (*Brevoortia tyrannus*) were the most commonly impinged fish species, making up 56.9% of total fish impingement in 1976–1977 and 36.5% in 1984–1985 (54.1% using the census data in 1984–1985). These two species made up 76.4% of the total impingement prior to and 84.2% (71.6%) of total impingement after deployment of the double barrier net system (Bailey 2005). The percent reduction in impingement was estimated by comparing numbers impinged in a 12-month period in 1984 and 1985 (after the second barrier net was deployed) with baseline numbers during an 18-month period in 1976 and 1977 (before deployment of any of the nets). There were 78% and 18% reductions in the impingement of fish and blue crab, respectively. However, these estimates were confounded by changes in river populations. To alleviate this bias, the estimated reductions were adjusted where this could be supported by finding good correlations ( $R^2 > 0.4$ ) between impingement and relative abundance for those individual species representing more than 1% of the impingement totals during both evaluation periods. Of the seven species meeting the 1% criteria, the relationship was judged sufficient for Atlantic menhaden, spot (*Leiostomus xanthurus*), white perch (*Morone americana*), hogchoker (*Trinectes maculatus*) and blue crab and insufficient for bay anchovy (*Anchoa mitchilli*) and Atlantic silverside (*Menidia menidia*). Proportionally adjusted estimates of reduction for these five species ranged from 82 to 98%.

The dominant biofouling species are the colonial hydroid *Garvia franciscana* and the bryozoan *Victorella pavidia*. Jelly fish (summer) and leaves (fall) are the predominant debris that collects on the outer net. To control biofouling and debris, the net panels are changed on a regular basis. All net panels are changed once every other week except in the summer during peak biofouling when panels are changed once or twice per week. The net changing process minimizes the potential for organism passage: as one net is removed by a boat, another net is set in place by a second boat. The new net is deployed just upstream of the support piles and allowed to drift into place with the current. After installation, divers perform an inspection and adjust the net bottom to ensure a good seal.

Each fall around mid-November the barrier nets are removed for ten days to two weeks. This is done to prevent impingement of Atlantic menhaden in the fall. It is believed that small juvenile or late larval stage menhaden go through the net in the spring or early summer and take advantage of the continuous flow of cooling water and associated food supply in the intake canal. They grow quickly, reaching a size of 102 to 152 mm (4 to 6 in.) by the fall, and are too large to pass back through the net in order to migrate downstream in the fall. Small impingement incidents can occur in late November if the nets are not removed and the fish allowed to escape.

Historically, the barrier nets were removed in early December when ice could damage the netting and redeployed in late February (Bailey 2005). However, in the late fall of 1996, the inner net was left in place with the top of the net submerged several feet below the water surface for as long as there was a threat of the river freezing.



**Figure 6-4**  
Chalk Point barrier net configuration (Loos 1986a, b)

### ***J.P. Pulliam Plant, Fox River, Wisconsin***

The J.P. Pulliam Power Plant, owned by Wisconsin Public Service (WPS) is a 380 MW coal-fired power plant located at the mouth of the Fox River on the southern end of Green Bay, Lake Michigan (R. Oswald, WPS, pers. comm. 1999). This is a six-unit plant with each unit having two forebays. All forebays are fed by a common tunnel that runs between the north and south intake. The north intake is located on the bay, while the south intake is at the interior end of a boat slip used for coal unloading and is located on the Fox River. Under the current operating arrangement, the north intake is closed so the source of all cooling and plant service water is the Fox River via the south intake.

The net system was initially installed in 1982. Prior to construction, a net system was tested that consisted of a net suspended from a floating log boom. In 1998, modifications were made to the system, including:

- A new bulkhead was constructed to ensure a better net seal along the vertical edge of the net end panel. Formerly, the end net panel draped up the sloped rip-rap shore.
- A win. lifting station was added for raising the end panel.
- Pilings were added inward from the vertical net line to prevent net billowing.

- The seal between the net bottom and the underwater surface was checked. Additional riprap was added to improve the seal.

The barrier net system is a two-level, open-grid steel structure. The net is a continuous sheet comprised of four panels, each approximately 8.5 m (28 ft) across and 4.3 m (14 ft) high. There are two separate nets; one is on the interior side of the steel structure and the other on the exterior side. The net manufacturer is FNT Industries of Menominee, Michigan. Flow to the plant ranges from approximately 10 to 23 m<sup>3</sup>/s (356 to 805 cfs / 230 to 520 mgd) across the face of the nets and into the plant intake. Corresponding velocities ranged from 0.06 m/sec to 0.15 m/sec (0.2 ft/sec to 0.5 ft/sec).

The four net panels are attached to roller-mounted I-beams that travel along five downrigger columns. There is a heavy nylon/plastic reinforcing material sewn over the net fabric along the vertical edge of the nets. The net is sandwiched along these edges and bolted to the I-beams with aluminum flat bar stock. A 9.5 mm (3/8 in.) diameter nylon reinforcing rope is sewn into the top and bottom edges of the net fabric at 51 mm (2 in.) intervals. The net fabric consists of multifilament knotless nylon netting with 6.4-mm (1/4-in.) square mesh. Fastened to the bottom of the net is a heavy chain to ensure that the net has a good bottom seal. Three to four piles per panel are driven approximately 0.4 m (15 in.) out downstream of the vertical net line to minimize net billowing under high flows. Billowing normally does occur to about 0.6 to 0.9 m (2 to 3 ft) past the driven pile. There is a plastic log boom out in front of the nets to reduce floating debris accumulation.

The only information found on net effectiveness is from the Technical Development Document in the Phase II Rule (EPA 2004), as quoted below:

“The JP Pulliam Station is located on the Fox River in Wisconsin. Two separate nets with 6-mm mesh are deployed on opposite sides of a steel grid supporting structure. The operation of a dual net system facilitates the cleaning and maintenance of the nets without affecting the overall performance of the system. Under normal operations, nets are rotated at least two times per week to facilitate cleaning and repair. The nets are typically deployed when the ambient temperature of the intake canal exceeds 37°F. This usually occurs between April 1 and December 1.

Studies undertaken during the first 2 years after deployment showed an overall net deterrence rate of 36 percent for targeted species (noted as commercially or recreationally important, or forage species). Improvements to the system in subsequent years consisted of a new bulkhead to ensure a better seal along the vertical edge of the net and additional riprap along the base of the net to maintain the integrity of the seal along the bottom of the net. The improvements resulted in a deterrence rate of 98 percent for some species; no species performed at less than 85 percent. The overall effectiveness for game species was better than 90 percent while forage species were deterred at a rate of 97 percent or better.”

The nets are put in service when the intake water temperature reaches 2.8° C (37° F) or by April 1 of each year. National Pollutant Discharge Elimination System (NPDES) permit conditions allow the nets to be raised after the temperatures are above this minimum or after April 1 when the potential for ice damage no longer exists. Normal procedure in the spring is to put the system into service as early as possible. The system stays in service until intake temperatures drop below 2.8° C (37° F), or December 1, whichever occurs later.

The nets can be rotated for cleaning or repair. Electric win., cables and pulleys are used for raising and lowering each net as a single unit. Under normal operation, the nets are rotated a minimum of two times per week (rotation between interior and exterior nets). Rotation takes approximately 10 min. Because the net is continuous, the entire net can be raised with a master switch. However, once the roller-mounted I-beams are lowered, an operator makes minor adjustments to each individual I-beam to ensure a good bottom seal.

The out of service net is cleaned using a fire hose or is manually picked clean. Cleaning takes about 1 hr. The out-of-service net remains suspended above the water to allow drying and to make any necessary repairs. Although repairs are infrequent, each net is replaced every year or two.

### ***Laskin, Colby Lake/Partridge River, Minnesota***

A seasonal barrier net was deployed at Laskin in 1985 and has been used continuously on a seasonal schedule since that time. The net is deployed from May 15 to September 30. In addition to fish protection, the net also keeps debris, mainly leaves, out of the screenhouse which helps to reduce operation and maintenance (O&M) requirements on the screens.

Laskin's flow capacity is 6.3 m<sup>3</sup>/sec (223.4 cfs /144 mgd). The net is approximately 183 m (600 ft) long and 5 m (16 ft) deep. The net manufacturer is Sterling Net and Twine. The net has three, 61-m (200-ft) panels connected by 12.7-mm (0.5-in.) polypropylene rope. The net material is 20 kg (44 lb) nylon Delta netting with 6.4-mm (1/4-in.) hexagonal mesh. The net is held in place by two shoreline anchors and 11 bottom anchors spaced approximately 15 m (50 ft) apart. The bottom anchors are 0.6 m by 0.6 m by 0.3 (2 ft by 2 ft by 1 ft) concrete blocks, each weighing about 272 kg (600 lbs). Lead weights 114 g (4 oz.) are spaced every 0.5 m (18 in.) along the length of the net's lead-line to keep the net anchored to the lake bottom. Floats with 851 g (30 oz) buoyancy are spaced every 0.3 m (12 in.) along the float-line to support the top of the net. There are 11, 5 kg (172 oz.) buoyancy floats connected to the bottom anchors. The net forms a semi-circular barrier approximately 31 to 46 m (100 to 150 ft) in front of the intake structure (Jasperson pers. comm. 2005). A smaller net (122 m [400 ft]) is used in the winter to reduce the effort required to keep the net ice free.

Impingement sampling was conducted weekly during the barrier net deployment period in 1985. The total number of fish impinged in 1975 and 1985 over the same period of time in both years (June 12-October 2) was 903 and 5, respectively, indicating a large reduction possibly due to the net. It is not possible to calculate the precise reduction since the population of young of the year black crappie in Colby Lake may have been greater or less in 1985 than in 1975.

The barrier net is deployed upstream from the screenhouse from May through October. The two main maintenance issues are the need to reposition the net if wave action causes the net to shift and buoy maintenance to keep the net afloat. Some mending is also needed to repair damage caused during installation or over time. The net is thoroughly cleaned when it is removed in October.

### ***Baker River, Baker River, Washington***

Puget Sound Energy's Baker River Hydroelectric plant is located on the Upper Baker River, Washington. The project is rated for a flow rate of 144 m<sup>3</sup>/s (5,100 cfs /3.3 billion gallons per



day [BGD]) (Puget Sound Energy 2002)). A barrier net is used to guide sockeye (*Oncorhynchus nerka*) and coho salmon (*Oncorhynchus kisutch*) to the entrance of a surface collector where they pass to a fish trap and holding facility (Puget Sound Energy 2002). An aerial photograph of the net installation is shown on Figure 6-5.

The guide net was installed in 1986, spanning the forebay and extending to a depth of 30.5 m (100 ft) with a mesh size of 2 in. In 1987, the mesh size was decreased to 6.4 mm (0.25 in.) and was made of nylon. The new mesh allowed only juveniles to pass under the net or to the surface collector. A full depth barrier net was installed in 1992, with a net depth of 87 m (285 ft). The net has a 0.1-m (4-in.) diameter inflatable hose for flotation at the surface, continuous cork floats at a depth of 15.2 m (50 ft), and 0.5-kg (1-lb) weights sewn in along the net bottom at 0.3 m (1 ft) spacing following the contour of the reservoir. For deployment, the first net section is anchored on shore and fed out into the water using a pontoon boat. The second section is then spliced to the first section and the process is continued to the third section. This section is then anchored to shore.

Puget Sound Energy also installed a barrier net at the Lower Baker River section in 1986 (Puget Sound Energy 2002). The powerhouse is rated for a total flow rate of 113 m<sup>3</sup>/sec (4,000 cfs/2.6 BGD). The net spanned the forebay with a depth of 30.5 m (100 ft). The net had a mesh size of 6.4 mm (0.25 in.).

In 2001, a full depth net was installed at the Lower Baker River section reaching a depth of 72 m (236 ft), extending from shore to shore. The net is supported by cork floatation across the top and 0.5-kg (1-lb) weights at the bottom sewn at 0.3 m (1 ft) spacing. The net is removed during off-migration period beginning in August and redeployed in February. The manufacturer for both nets is Redden Marine (Puget Sound Energy 2002).



**Figure 6-5**  
**Baker River aerial photograph of barrier net**

### **Arkansas Nuclear One, Dardanelle Reservoir, Arkansas**

Arkansas Nuclear One, owned and operated by Entergy Arkansas, Inc. and located on Dardanelle Reservoir, installed a seasonal barrier net in 1999. The net is deployed about 120 days annually,

between late October and early March. The winter deployment was intended to block the entrance of gizzard shad (*Dorosoma cepedianum*) and threadfin shad (*Dorosoma petenense*) into the CWIS during cool months when they are subject to the natural effects of cold shock.

The barrier net is installed outside an intake canal in the reservoir. The net manufacturer is Mid Lakes located in Knoxville, TN. The net is 457 m (1,500 ft) long and 20 ft deep. The net material is nylon with bar mesh sizes of 9.5 and 12.7 mm (3/8 and 1/2 in.). The net is made up of six, 76-m (250-ft) wide panel sections. The plant flow capacity is 38 m<sup>3</sup>/s (1,322 cfs/854 mgd). Velocities are approximately 0.01 m/sec (0.04 ft/sec) (Adams pers. comm. 2006).

Installation and take down require about 240 man-hrs. While installed, the net is checked daily either by boat or from land. Daily inspections require an average of 3 man-hrs per day. On a periodic basis, the net is lifted and partially cleaned. Installation and takedown of the net requires approximately 240 man-hrs (Adams pers. comm. 2006). The nets are in 250 ft sections; two new sections are purchased each year to replace sections of worn net.

### ***LaSalle County Generating Station, Cooling Pond, Illinois***

Exelon Corporation's LaSalle County Generating Station has a barrier net installed upstream of the intake on a cooling pond to reduce fish impingement, in particular gizzard shad (*Dorosoma cepedianum*). LaSalle's flow capacity is 82 m<sup>3</sup>/s (2,890 cfs/1,868 mgd). The barrier net is 1,200 ft long and 20 ft deep. The net material is polyethylene with a mesh size of 9.5 mm (3/8 in.). The original installation in 1982 had two parallel nets installed. During the early 1990s, one net was removed to reduce O&M costs (Kehring pers. comm. 2006) and the station now operates with a single net.

The barrier net is visually inspected by divers and cleaned as necessary using a high pressure spray wash. The net is replaced every four years. During net replacement, the new net is installed prior to the removal of the old net to prevent the entrance of fish (Kehring pers. comm. 2006).

### ***Crystal Falls, Paint River, Michigan***

The City of Crystal Falls owns and operates the Crystal Falls Hydroelectric facility which is located in Iron County, Michigan on the Paint River. By FERC Order, a seasonal barrier net is installed to reduce the entrainment of fish. The net is 30.5 m (100 ft) long and the maximum water depth is 6 m (20 ft). The net material is knotted nylon with a mesh size of 12.7 mm (1/2 in.).

The barrier net is deployed from early spring until the beginning of the fall season. A barrier net inspection is conducted daily, including visual observations and pulling on the vertical ropes to dislodge debris. The barrier net is lifted for cleaning as often as necessary, but not less than once a month. The cleaning schedule required approximately sixteen days in 2000. The net is maintained and cleaned by pulling the vertical ropes up and shaking the net vigorously to dislodge the debris. Underwater inspections are conducted every two weeks for the first 10-12 weeks the net is deployed (FERC 2001a,b).

### ***Highline Irrigation Canal, Highline Lake, Colorado***

Colorado State Parks installed a barrier net in 1999 at the spillway approach of Highline Lake to reduce or eliminate continuous introduction of nonnative, warm-water fish, specifically

largemouth bass (*Micropterus salmoides*), bluegill (*Lepomis macrochirus*) and black crappie (*Pomoxis nigromaculatus*), into the Colorado River. Facilities located on this reservoir are in use seasonally, primarily for irrigation. The barrier net material is Dyneema with a mesh size of 6.4 mm (0.25 in.). The net is 111 m (363 ft) long and 5.8 m (19 ft) deep. Approach velocities are less than 0.3 ft/s. The maximum intake flow is approximately 56.6 m<sup>3</sup>/s (2,000 cfs/1,300 mgd).

Rigging attaches to the sides of the spillway and to 13 anchors secured on the bottom of the lake. The buoy system consists of 2.4-kg (85-oz) buoys for the main panel and 0.7-kg (23-oz) buoys for the skirts. The net is manufactured in 82-m (270-ft) panels, which are attached to riblines. If the design loading is exceeded, the net is designed to fail in the middle of the 82-m (270-ft) panel, leaving the ribs and top/bottom lead intact. The net is designed to flex with the current and has top and bottom skirts for when the water depths change to prevent fish from escaping under or over the net. Ayres Associates, Inc. of Boulder, Colorado designed the net and anchoring system. Redden Nets of Bellingham, Washington was the net manufacturer (Ayres Associates 2001).

Visual inspections of the net and buoy line are conducted weekly. Divers perform underwater surveys every month examining the net for small tears and determining if the net needs to be cleaned. Cleaning is necessary prior to water entering in the canal in late March. The barrier net is cleaned from a barge using a spray wash system. Additional cleaning of the top is necessary prior to the fall season when large amounts of water are dumped from the canal and flow through the lake.

It has been determined that cleaning the top 1.8 to 2.4 m (6 to 8 ft) of the net is possible by using the barge and win. and cleaning the net with a pressure washer system. Cleaning the remainder of the net requires using divers and a high pressure cleaning system. The length of time the net can be deployed was still being evaluated in 2001 (Ayres Associates 2001).

## **Case Studies – Hydroelectric Application**

### ***Ludington Pumped Storage Plant, Lake Michigan, Michigan***

The largest (3.9 km or 2.5 miles) barrier net installed to date is at the Ludington Pumped Storage Plant, operated by Consumers Energy Company on Lake Michigan (Guilfoos et al. 1995; Reider et al. 1997). The net was first deployed in 1989 and has undergone substantial modifications since then. Changes have included modifying the net's fabric, the amount of flotation, the addition of top and bottom skirts, and the installation of anchor piles. The Ludington net is deployed each year from mid-April to mid-October, the time frame of highest fish abundance. Species of concern at Ludington include alewife (*Alosa pseudoharengus*), yellow perch (*Perca flavescens*), salmonids (Family Salmonidae) and rainbow smelt (*Osmerus mordax*). The net is not used during the winter because storms and icing conditions make deployment of the net at that time impractical. The maximum flow at Ludington is 1,869 m<sup>3</sup>/s (66,000 cfs/42.6 BGD).

The 3.9 km (2.5 miles) long barrier net (the length necessary to accommodate the pumping return flow and minimize hydraulic force on the net), manufactured by Pacific Netting or Redden Marine, is set in open water around the intake jetties. The main portion of the net is located 1 km (0.62 miles) offshore, parallel to the shore. This parallel section is approximately 13.7 m (45 ft) deep. At both ends of the parallel section, there are perpendicular sections extending to the shore to close access to the waters closest to the plant. The barrier net is constructed with Dyneema (a

“superfiber” from the Dutch company DSM) material and has 19 mm and 12.7 mm (3/4 in. and 1/2 in.) bar mesh openings. The net consists of 62 panels ranging in length from 30.5 m (100 ft) to 91.4 m (300 ft) that are sewn together for deployment. An aerial photograph of the net installation is shown on Figure 6-6.

The biological effectiveness of the Ludington barrier net was determined via an index of fish population size, by species and size, inside and outside of the net. A report to FERC prepared by Consumers Energy Company and Detroit Edison Company (2005) provides an excellent overview of the history of the net; the many enhancements that have been made to improve net effectiveness and ease O&M activities; and the ability of the net to reduced fish passage.

As a result of design enhancements and maintenance activities, overall effectiveness for target species (i.e., species of commercial, sport and recreational value, namely, rainbow smelt, alewife, yellow perch, chubs [Family Cyprinidae], Chinook salmon [*Oncorhynchus tshawytscha*], coho salmon [*Oncorhynchus kisutch*], steelhead [*Oncorhynchus mykiss*], lake trout [*Salvelinus namaycush*] and brown trout [*Salmo trutta*]) was 92.1% in 2005. Effectiveness for non-target fish species (all other species combined) was 85.1%. Target species made up 90.1 % of the 2005 collection (Consumer Energy Company and Detroit Edison Company 2005).

Inspections of the net are performed often. Surface observations are made twice daily from shore and, when possible, from a boat. Subsurface inspections are performed once daily. Dive teams make small repairs and perform the subsurface inspections. The divers also clean the net with spray wands to combat the build-up of algae and zebra mussels (*Dreissena polymorpha*). The net was cleaned four times during 2005 (Consumer Energy Company and Detroit Edison Company 2005).



**Figure 6-6**  
**Ludington aerial photograph of barrier net**

### ***Pine Hydroelectric Project, Pine River, Wisconsin***

In the summer of 1990, Wisconsin Electric (WE) installed and tested a prototype barrier net system at the Pine Hydroelectric Project (Pine) on the Pine River in Wisconsin (Stone and Webster 1991). The 25-mm (1-in.) nylon mesh (stretch) barrier net was 79.2 m (260 ft) in length, ranged in depth from 0.6 to 10.7 m (2 to 35 ft), and was placed along an angled log boom located directly upstream of the power canal intake, as shown on Figure 6-7. Table 6-2 provides pertinent project information. The top of the net was set 30.5 to 45.7 cm (12 to 18 in.) below the water surface to avoid entanglement of floating debris. Pine has a flow capacity of approximately 18 m<sup>3</sup>/s (640 cfs/414 mgd), equivalent to the flow of a moderately sized CWIS. Average approach velocities ranged from 0.03 to 0.15 m/sec (0.1 to 0.5 ft/sec).

In 1991, additional floatation was added to raise the main net to within 15.2 cm (6 in.) of the surface, and a surface net was added to the barrier net section closest to the dam to reduce fish passage over the net in this area. The bottom of the barrier net was held in place by using 36.3-kg (80-lb) iron blocks, spaced about every 3 m (10 ft) (Michaud and Taft 2000). The barrier net was deployed from June to November of 1990 and April to October of 1991. During the winter, the net was lowered to the bottom of the reservoir for storage.

The Pine barrier net was evaluated to determine its effectiveness in reducing entrainment of riverine fish, which included largemouth bass (*Micropterus salmoides*), bluegill (*Lepomis macrochirus*), channel catfish (*Ictalurus punctatus*) and white sucker (*Catostomus commersonii*), through the project's turbines. Effectiveness was evaluated by comparing power canal

entrainment data prior to net deployment in 1990 to data with the net in place in 1991 and by comparing mark-recapture studies with fish released upstream and downstream of the barrier net.

Power canal entrainment was estimated from the number of fish caught in a 9.1 m (30 ft) trap net that sampled the entire canal flow. Net sampling was performed for a total of 253 hrs prior to deployment of the barrier net, and 1,593 hrs following deployment. Entrainment monitoring before and after the barrier net was installed demonstrated the net was successful at reducing the numbers of adult fish passing into the intake canal. The barrier net reduced fish entrainment by 85 to 99% from the May through August of 1991 (SWEC 1991; Michaud and Taft 2000).



**Figure 6-7**  
**Pine barrier net**

Plante et al. (1997) review the design, operation and maintenance of the net, in particular its response to changes in flow, debris loading, and biofouling. To address concerns over heavy debris loading, the existing log boom was modified to support the net. Safety rails, new decking and floatation were added for stability. The estimated expenses for these modifications were \$2,800 for materials and 160 hrs of labor.

Biofouling on the net mesh was controlled by using a long brush to scrape the net on a periodic basis. Heavy surface debris was removed by reversing flow through the net by opening an adjacent spillway gate and spilling 10 m<sup>3</sup>/sec (350 cfs). In 1991, a protective coating of Flexibar, an antifouling substance was applied to the net to limit biological growth. In addition, new inspection methods were employed to estimate the frequency of cleaning needed for long-term deployment. The net was inspected by divers once each month during the 1991 deployment period.

During the initial deployment period the Pine barrier net design was easy to install and maintain. The net effectively limited the passage of fish (EPRI 1994a; Michaud and Taft 2000). There were occasional periods of heavy debris loading, but plant flows were not seriously impaired. Reversal of flow through the net was an effective procedure for cleaning the net when river flows were high enough to permit spilling. Brushing was necessary to keep the net mesh clean and free of silt and debris. The storing of the net at the lake bottom in the winter allowed microorganisms to feed on the biofouling on the net material while in the stored position.



## **Brule Hydroelectric Project, Brule River, Wisconsin**

Wisconsin Electric (WE) installed a barrier net system at the Brule Hydroelectric Project on the Brule River in Wisconsin in 1999. The barrier net spanned 217 ft across the front of the hydroelectric project forebay and was suspended by a cable. The 9.7- by 13-mm (0.38- by 0.5-in.) knotless nylon mesh barrier net extended about 6.1 m (30 ft) below the water surface and the bottom of the net was attached to weights to hold the net vertical. The net was attached to the top cable by clevises and nylon pulleys. This unique deployment system allows that net to be installed and removed in a similar manner to operating a clothes line, as shown on Figure 6-8. The top cable support is anchored to the dam at one end and the other end by a suspended concrete block to maintain a constant tension on the cable. This system limits tension on the cable resulting from debris loading on the net. Brule has a flow capacity of approximately 39 m<sup>3</sup>/s (1,377 cfs/890 mgd). Average approach velocity to the net is 0.06 m/sec (0.2 ft/sec).



**Figure 6-8**  
**Brule barrier net**

The Brule net was designed to be a partial depth net due to the fact that studies confirmed the existence of a seasonal, intense stratification that sets up in the flowage from late spring to early September and creates dissolved oxygen levels well below 3.0 mg/l at depths greater than 9.1 m (30 ft). The net design rationale was to place the net where fish are most likely to be and at the times of greatest abundance.

In 1999, a FERC approved study (Normandeau 2000) was conducted to estimate the effectiveness of the barrier net. There were two test periods in the experimental design: July 7-15 and September 29 through October 13, 1999, which were selected to correspond to periods of peak fish entrainment. Within each sampling period, a series of replicates were conducted. Each replicate included a 24-hrs of sampling with the net in and 24-hrs of sampling without the barrier net. Individual samples were collected at 2 hr intervals (Normandeau 2000).

Total number of fish collected with and without fish was low (416 fish). There were significantly more fish entrained without the net deployed when both test periods were combined and for July alone, but there were no significant differences in entrainment rates during the September/October period. The overall barrier net effectiveness was estimated to be 50%. Effectiveness for fish <100 mm was 61%. The net did not significantly reduce entrainment of fish >100 mm, but the sample size was low (55 fish in July and 43 fish in September/October).

Overall species effectiveness of fish <100 mm (3.9 in.) were: white sucker (*Catostomus commersonii*; 84%); smallmouth bass (*Micropterus dolomieu*; 83%); yellow perch (*Perca flavescens*; 70%); walleye (*Sander vitreus*; 36%). The barrier net was not effective at reducing bluegill entrainment (Normandeau 2000). Agency comments to FERC (U.S. Fish and Wildlife and Michigan Department of Natural Resources) stated that the results of the study were inconclusive (FERC 2001a,b).

The Brule net experiences heavy biogrowth (Figure 6-8) which, on at least one occasion, has caused the net to lift to the water surface rendering it ineffective. The pictures on Figure 6-8 were taken in September 2004, about one month after the net was cleaned by divers and just before the net was removed for winter storage. The net is stored for the winter in the hanging position from an onshore tower (see right picture, Figure 6-8).

### **Hayward Hydroelectric Project, Namekagon River, Wisconsin**

Northern States Power Company (NSP) (now Xcel Energy) installed a seasonal barrier net at the Hayward Hydroelectric Project in 1999. The net is located in the bay just above the intake on the west bank of the Namekagon River in Wisconsin. The net is about 22.9 m (75 ft) long by 3 m (10 ft) deep and is knotted, 9.5 mm (3/8 in.) square nylon mesh. The top of the net is supported by floats and a steel cable strung between two anchor points. The bottom is anchored by four, 36.3- to 45.4-kg (80- to 100-lb) weights spaced evenly along the lake bottom. A 1 m (3 ft) deep bottom skirt helps maintain a tight closure. Hayward has a flow capacity of approximately 5 m<sup>3</sup>/s (180 cfs/116 mgd). Velocities approaching the net are considerably less than 0.15 m/sec (0.5 ft/sec). The barrier net is intended primarily to protect young-of-the-year walleye (*Sander vitreus*) and is installed from May through approximately June 15 each year (FERC 1997). The Wisconsin Department of Natural Resources (WDNR) is responsible for maintaining and cleaning the barrier net as necessary (FERC 1997).

### **Banks Lake, Columbia River, Washington**

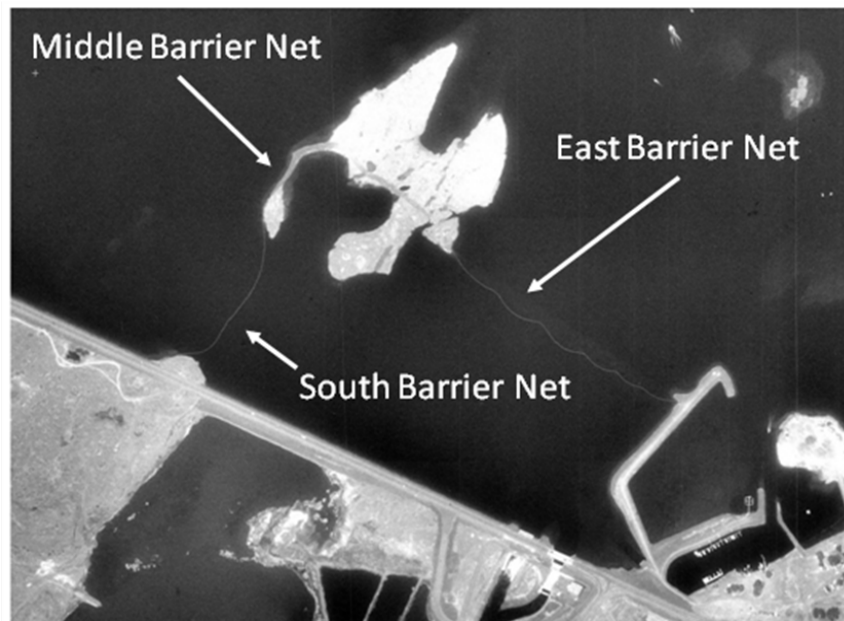
A fish barrier net was installed in Banks Lake Reservoir in 1977 to prevent entrainment of mature Kokanee salmon (*Oncorhynchus nerka*) into the main irrigation canal. Banks Lake is located in Washington and is supplied by a feeder canal from a pumping station on Franklin D. Roosevelt Reservoir. The barrier net is located in front of the main irrigation canal and positioned between two islands and the lake shore in three net sections. The maximum irrigation withdrawal is 224 m<sup>3</sup>/s (7,910 cfs/5.1 BGD). The south net section is 379 m (1,243 ft) long with a maximum depth of 24 m (78.7 ft), the middle section is 126 m (413.4 ft) long with a maximum depth of 8 m (26.2 ft), and the east net is 859 m (2,818 ft) long with a maximum depth of 12 m (39.4 ft). An aerial photograph of the net is shown on Figure 6-9; it appears the middle section may have been replaced with a rock dike. The net is made of knotless Dacron material with a stretch mesh of 8.3 cm (3.25 in.). The net is supported by anchors and floats. Three pairs of anchors set at 85 m (287 ft) spacing supports the south net; one anchor pair supports the middle net; and four anchor pairs at 166 m (544 ft) spacing supports the east net.

The screening efficiency of the barrier net was evaluated by numerous methods: sampling the fishes entrained in the irrigation canal with large nets, mark and recapture of adult Kokanee in the reservoir, estimates of the number of beach spawners, sonic tracking near the net, census of the sport fishery, and mortality of Kokanee gilled in the net. Based on four years of catch data,



annual canal entrainment of Kokanee declined from an average of 64% before installation of the net to 10% afterwards (Stober et al 1983). Based on mark/recapture studies, an estimated 35,391 adult Kokanee were retained in the lake during the fall of 1978 (96% retention of the population). It was concluded that the net provided an economical means of reducing the entrainment loss of adult Kokanee through a spillway.

Net cleaning at Banks Lake is conducted using a flat bottomed fiberglass boat and an attached small floating platform. All the cleaning is done on the boat by hauling the net onto the boat with a power block and using a high pressure spray wash to remove debris and biogrowth. The power block pulls the boat along the net length as it lifts the net to the boat deck.



**Figure 6-9**  
**Banks Lake fish barrier net – aerial photograph**

### ***Puntledge Hydroelectric Project, British Columbia***

A barrier net study (Benneyfield 1992, 1993) was conducted during 1991 and 1992 at the Puntledge Hydroelectric Project in British Columbia. The facility is owned by B.C. Hydro. The diversion net was installed in the Puntledge River at an angle across the entrance to the project's power canal and diverted fish, primarily coho salmon (*Oncorhynchus kisutch*), to a bypass located at the dam. The net was 43 m (141 ft) long and 25 ft deep. The net material was of tarred knotless nylon 210/20, 19-mm (3/4-in.) stretch mesh which was square-hung from a float line. Secondary nets of marquisette mesh overlapped the two ends of the net, and the bottom of the net was weighted by a cable to follow the contour of the river bed. The float line and upper section of the net extended about 30 cm (11.8 in.) above the water level and was hooked to a series of Topper floats. Flow passing through the net consisted of the powerhouse flow 27.2 m<sup>3</sup>/s (960 cfs/620 mgd) maximum and a bypass flow 2.8 m<sup>3</sup>/s (100 cfs/65 mgd) (for most of the two study periods) which was discharged into the bypass reach via a sluice adjacent to the powerhouse. River flows during 1991 were quite low, ranging from 13.4 to 16.6 m<sup>3</sup>/s (474 to 586 cfs) over the

study period, but were higher in 1992 (33.2 to 40.4 m<sup>3</sup>/s [1,173 to 1,425 cfs]) (Benneyfield 1992, 1993).

Yearling coho salmon smolts were the principal test subjects used to evaluate the barrier net (Benneyfield 1992). Traps placed in the bypass enumerated fish that were successfully diverted by the net while traps in the sluice and tailrace enumerated fish that circumvented the net. Trap catches were enumerated twice a day, seven days a week, usually between 0800-0900 h and between 1600-1900 h. Fish caught in the traps were sorted by species, examined for marks, and counted.

This evaluation showed that 99.3% of the estimated 107,890 coho smolts that migrated in the spring of 1991 were effectively diverted by the net. Impingement was negligible and was limited to the highest velocity area of the net. The netting was well-sealed along the bottom and at both ends against the face of the dam and bedrock bank, respectively. There were some problems with the net lifting off from the bottom of the channel (Benneyfield 1992).

The study was conducted again in 1992 under the substantially higher flow conditions. Water velocities measured on May 4, 1992 at a river discharge of 37.5 m<sup>3</sup>/s (1,324 cfs) indicated that the approach velocities (perpendicular to the net) ranged from 0.13 to 0.5 m/sec (0.44 to 1.70 ft/sec). While 132,123 fish were successfully diverted to the bypass, impingement (measured as the number of dead fish on the screen each morning) occurred as follows: 272 coho smolts, 2 coho fry, 22 Chinook (*Oncorhynchus tshawytscha*) fry, and 41 sculpins (Family Cottidae). Most of these fish were impinged on the net at the downstream section of net where velocities were highest and where most of the leafy and woody debris accumulated.

Although the diversion net was highly effective over the 2 years of the study (Benneyfield 1992, 1993), B.C. Hydro concluded that the net would be less effective during years with higher stream flow. The results of one study (Benneyfield 1992, 1993) indicate that a barrier net installed at an angle to the flow can be effective in diverting fish to a bypass. The diversion net was removed in 1993, and Eicher screens were installed to divert fish from the project's penstocks (Smith 1997).

### ***Pickering Nuclear Generating Station, Lake Ontario, Ontario, Canada***

Due to the negative effects of consistent algae blooms and the need for fish protection, a barrier net was designed and installed at Ontario Power Generation's Pickering Nuclear Generating Station, Lake Ontario, Ontario, Canada (Lew 2012). The net surrounds the entire intake channel at a length of 609.6 m (2,000 ft) and consists of 12.7- by 12.7-mm (0.5- by 0.5-in.) mesh made of Dyneema. The length of the net was selected so that if 90% of the net was clogged, 61.0 m (200 ft) would remain open, which is the same length as the width of the intake channel. The net deployed an anchoring system and the top of the net was equipped with a float line. More resilient, permanent steel panels were installed at the intake groin interface. A 1.5-m (5-ft) skirt was installed to minimize debris carryover and wave action stress. In the event of debris/algae over load, the net is designed sink, an inherent fail safe concept. The net is cleaned, as needed by an underwater dive team using high pressure sprays.

Modifications were introduced in 2011 as a result of 2010 algae loading experience and fish impingement impacts. Modifications included an 8 ft skirt extension, increasing the mesh size to 6.4 by 6.4 cm (2.5 by 2.5 in.) to allow greater water passage, and the addition of 10 crown bouys

for additional floatation. After these modifications, fish impingement and algal impacts were reduced substantially.

### ***Osage Hydropower Plant/Bagnell Dam, Osage River, Missouri***

Ameren Missouri owns and operates Osage Hydropower Plant/ Bagnell Dam which is located on the Osage River, approximately 35 miles southwest of Jefferson City, Missouri, and approximately 82 miles upstream of the confluence with the Missouri River. The Plant is operated primarily to generate electricity during peak demand periods, but also provides environmental enhancements, recreational opportunities, and flood control. By FERC Order, a seasonal barrier net was installed in December 2008 to reduce the entrainment of fish (Ameren 2011).

The net is 1,100 ft long and spans across the reservoir 850 ft with a maximum water depth of 100 ft. It was installed 103.6 m (340 ft) upstream of the reservoir. The net is made of 5.1 cm (2 in.) mesh Dyneema material with a bottom and top skirt. A pre- and post-net installation comparison survey was conducted to describe the success of the barrier net at reducing mortality and injury of fish below Bagnell Dam during spring months (April-June).

Pre-net installation fish surveys were conducted in 2005-2006 and post-net installation fish surveys were conducted in 2009-2010. Both pre- and post- net surveys lasted for 12 weeks and spanned from April 1 to June 30 with the exception of 2009, during which sampling was delayed until mid-May. Fish surveys were also conducted during October in 2009 and 2010 to account for differences in species composition and abundance after destratification during the fall season.

At 10-min intervals, a boat was driven crosswise from bank to bank downstream of the downstream side of the dam on a predetermined transect. All dead or dying fish along the transect were collected in 18.9-L (5-gal) buckets until the end of the interval. All fish were subsequently identified, measured, and visible injuries were recorded. Fish collected were assumed to have passed the dam through turbine entrainment. Fish that were capable of passing through the mesh (maximum mesh diameter= 2.8") were removed from net success analysis.

Freshwater drum (*Aplodinotus grunniens*) was the dominate species in 2005, 2006, and 2009 (representing 46.9, 44.3, and 60.9% of the total, respectively) while black crappie (*Pomoxis nigromaculatus*) and white crappie (*Pomoxis annularis*) were the dominate species in 2010 (26.3% and 21.1%, respectively). Dead fish collected considered too large to pass through the mesh were substantially less during post net surveys (Table 6-3). Despite considerable decrease in sample size from pre- net to post-net installation, there is still concern of the effectiveness of the net. During the October fish survey collections in 2009 and 2010, 67 and 66 dead fish were collected, respectively. This is a reduction of 54% and 82% after destratification.

**Table 6-3**

**Number of dead fish collected and percent of fish collected considered too large to pass through the mesh during pre- and post-net installation**

|          | <b>Year</b> | <b>No. Dead Fish Collected</b> | <b>% Too Large to Pass Mesh</b> |
|----------|-------------|--------------------------------|---------------------------------|
| Pre-Net  | 2005        | 2,709                          | 15%                             |
|          | 2006        | 782                            | 19%                             |
| Post-Net | 2009        | 1,239                          | 2%                              |
|          | 2010        | 360                            | 5%                              |

***J. R. Whiting Plant***

Consumers Power Company (CPC 1984, 1985) has demonstrated that a barrier net can substantially reduced the numbers of fish impinged at the J. R. Whiting Plant in Michigan. Gizzard shad and yellow perch are the primary species of concern at the Whiting facility. Continued effective operation and maintenance of the deterrent system has been credited with impingement reductions observed since its installation in 1980. Consequently, the barrier net was considered to be the best technology available for minimizing environmental impact at the plant by the Michigan Water Resources Commission (WRC) in 1982.

Monitoring, verification, and reporting of net performance at Whiting were required by the WRC. Monitoring included weekly inspections by divers to verify proper net installation, to identify and correct any non-sealed areas in the net and to determine whether any accumulation of dead gizzard shad has occurred on the channel bottom. Effectiveness monitoring and maintenance activities were reported on a monthly basis to the Michigan Department of Natural Resources (DNR).

The key indicator species at the Whiting Plant are gizzard shad during the fall and yellow perch during the spring. Impingement of these species was greatly reduced with the barrier net in place compared to the numbers impinged prior to barrier net use (monitoring results through 1984 are shown on Figure 6-10).

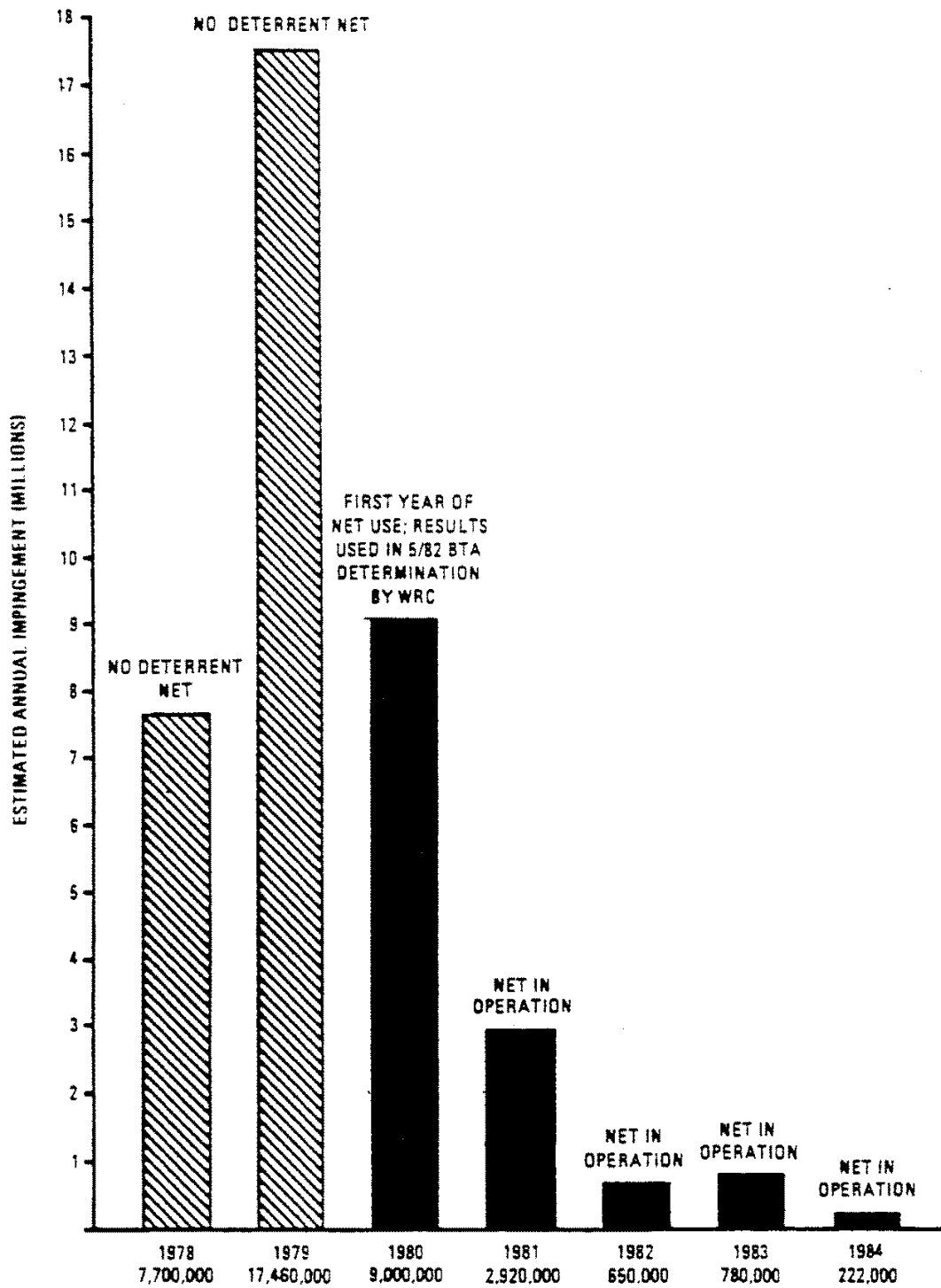


Figure 6-10  
 Estimated annual fish impingement at the J. R. Whiting Plant from 1978 through 1984 (CPC 1984)



# 7

## AQUATIC FILTER BARRIER

### Introduction

There are limited data available on the deployment of aquatic filter barrier (sold commercially as Gunderboom® Marine Life Exclusion System™ – MLES) for the protection of fish at water intakes. The AFB consists of polyester fiber strands that are pressed into a water-permeable fabric mat (Figure 7-1). This material can be perforated to allow greater flow rates. In addition, Gunderboom also developed a woven material with greater opening sizes than the original fabric mat.

Because of its limited application, the AFB system should be considered experimental for application at cooling water intakes (CWIS). Long-term deployment of the AFB at the Lovett Generating Station (described below) resulted in substantial improvements in anchoring and cleaning systems. Because AFB is one of a few technologies suitable for reducing entrainment and has potential to be biologically effectiveness, AFB is an alternative that facilities can consider for reducing both impingement mortality and entrainment.

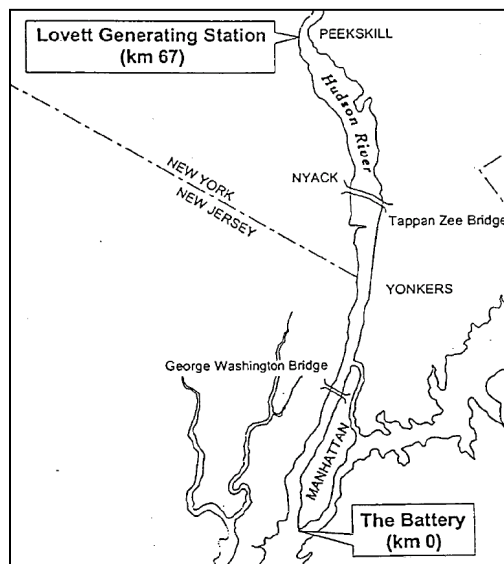


**Figure 7-1**  
**Close-up of perforated AFB material (courtesy of Alden)**

## Case Studies – CWIS Application

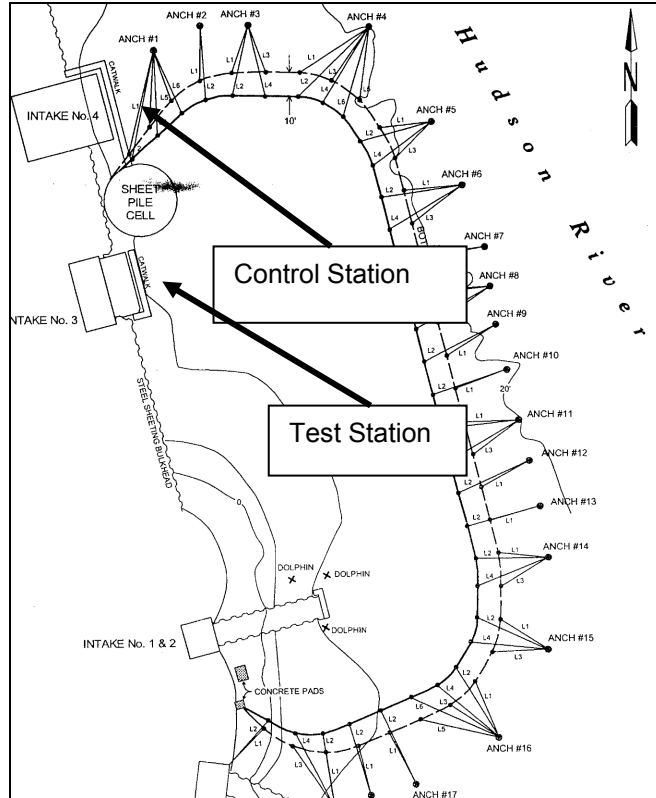
### ***Lovett Generating Station***

An AFB was installed at the Lovett Generating Station on the Hudson River in New York in 1994 (Figure 7-2). Lovett, now decommissioned, was a three unit, fossil fuel power plant with a 462-MW capacity and used 391-MGD of cooling water in its once-through cooling system. A subsequent 11-year evaluation of the engineering and biological performance of the AFB was undertaken. Biological evaluations conducted between 1995 and 2001 compared the entrainment rates of a protected intake to that of an unprotected intake (Figure 7-3). Later biological evaluations conducted between 2004 and 2006 evaluated a full scale AFB installation at Lovett Station with comparisons made between the inside (protected) and the outside (unprotected) of the AFB (Figure 7-4).

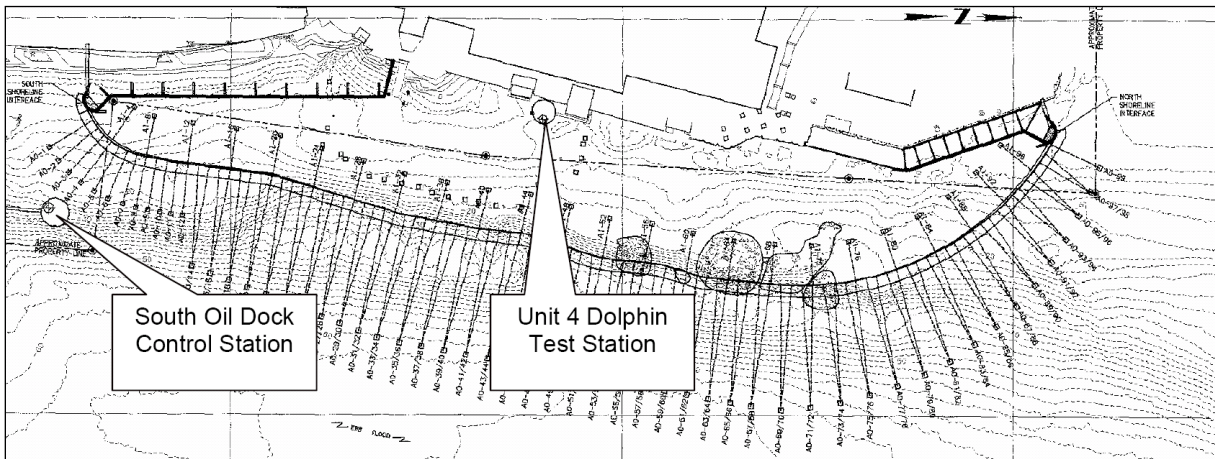


**Figure 7-2**  
**Location of the Lovett Generating Station on the Hudson River, NY (LMS 1996b)**





**Figure 7-3**  
 Site plan of the AFB deployment at the Lovett Generating Station showing sampling locations for entrainment sampling conducted between 1995 and 1999 (LMS 1998a,b).



**Figure 7-4**  
 Site plan of the AFB deployment at the Lovett Generating Station showing sampling locations for entrainment sampling conducted between 2004 and 2006 (ASA 2004).

Biological evaluation of the AFB began during the summer of 1995 (LMS 1996b). The AFB deployed was 5 mm thick with an apparent opening size (AOS) of 20  $\mu\text{m}$ . The entire AFB measured roughly 122 m (400 ft) wide by 6 m (20 ft) high and was designed to filter the entire Unit 3 flow of 163.5 m<sup>3</sup>/min (43,200 gpm; 96 cfs) at an average velocity of 15.2 mm/s (0.05

ft/s). During this study, a total of 81 ichthyoplankton samples were collected at each of the intakes being evaluated (control and test, see Figure 7-3). Samples were collected in 30-min intervals every 4 hrs over a 24-hour period. Based on pump flow rate, each sample comprised approximately 34.1 m<sup>3</sup> (9,000 gallons). All pumped samples were screened through a 500- $\mu$ m plankton net. Concentrations of ichthyoplankton collected during this evaluation indicated that the AFB was successful in reducing entrainment by 82% over controls.

During the evaluation period, the AFB experienced a number of engineering difficulties including overtopping due to plugging of the filter fabric with suspended silt and failure of the anchor and support lines. These engineering issues were the likely cause of the decreasing effectiveness of the AFB over the study period. Initial biological effectiveness was 97%, but decreased to 61% by the conclusion of the study.

Based on the promising biological results of the 1995 evaluation, a feasibility study was conducted in 1996 to evaluate the efficacy of expanding the AFB to protect the cooling water intake structures of Units 3, 4, and 5 (LMS 1997). This AFB differed from the one evaluated in 1995 in that two layers were used for additional strength. Overtopping of a 29.9-m (98-ft) section of the 243.8-m (800-ft) AFB occurred within the first 30 min of deployment. Significant failure of the anchoring system necessitated removal of the expanded AFB within 22 hrs of its deployment. It was concluded that the combined flow rate of Units 3, 4, and 5 (1,027.6 m<sup>3</sup>/min [271,463 gpm; 605 cfs]) exceeded the AFB's designed flow rate. Though part of the original scope, no biological sampling was conducted because of the failure of the anchoring system.

Evaluation of the AFB designed to protect Units 3, 4, and 5 was continued in 1997; however, modifications were made to the 243.8-m (800-ft) AFB so that it could be used to protect only Unit 3 (LMS 1998a,b). A 121.9-m (400-ft) section of AFB was, therefore, cut from the original 243.8 m (800 ft) used in 1996 testing. Additionally, the anchoring system was updated from Danforth anchors to concrete blocks measuring 0.9 by 0.9 by 1.8 m (3 by 3 by 6 ft) and weighing 3,674.1 kg (8,100 lbs) each. It was concluded that the concrete block anchors adequately anchored the 121.9-m (400-ft) AFB and did not move throughout the study period. The airburst system was shown to be most effective in sections of the AFB that matched the bathymetry of the river closely. In sections that did not match the bathymetry well, airbursting was less effective in keeping the AFB clean. The indication was that if the AFB depth did not closely match the depth of the water column, excess AFB material would billow and prevent effective cleaning of the upper parts of the material. The study period ended when a major tear in the fabric was deemed too difficult to repair in place.

A new AFB was fabricated for testing in 1998 with 0.5-mm (0.02-in.) perforations to allow adequate filtering capacity. The AFB was deployed around the Unit 3 cooling water intake structure and measured 152.4 m (500 ft) long and between 7.6 and 9.1 m (25 and 30 ft) deep. The new AFB with 0.5-mm (0.02-in.) perforations demonstrated a significant improvement in filtering capacity and was successful in filtering the entire Unit 3 flow of 163.5 m<sup>3</sup>/min. (43,200 gpm; 96 cfs). The new automated airburst cleaning system was effective in keeping the AFB clean, however it was noted that it would benefit greatly from a programmable function allowing for cleaning to be coordinated with tidal cycle (LMS 1998a,b).

Additional biological evaluation of the AFB was conducted at Lovett in 1998 with this new deployment (ASA 1999 and LMS 1998a,b). Similar to testing in 1995, simultaneous entrainment sampling was conducted at the intakes for Unit 3 (protected) and Unit 4

(unprotected). Sampling was conducted twice a week at night from June 11 through August 31 (excluding August 11–19). Each day of sampling yielded 30 samples (15 from Unit 3 and 15 from Unit 4), for a total of 702 individual samples. Samples were collected from three depths. Samples were pumped with a trash pump to a net/barrel sampling system. The plankton nets had a 505 µm mesh. Volumes of sampled water were recorded with a digital flow meter.

A total of 6,343 eggs, larvae, and juveniles were collected. Forty-two percent (2,645) were collected from Unit 3 and 58% (3,698) from Unit 4. The most abundant species was bay anchovy (*Anchoa mitchilli*), comprising 68% of the total collected. Other abundant species were striped bass (*Morone saxatilis*), naked goby (*Gobiosoma bosc*), and river herring (*Alosa* spp.), comprising 29% of the total collectively. The majority (89%) of organisms collected were post yolk-sac larvae. The four notable periods of peak entrainment were early to mid-June, early July, early August, and late August. The results of sampling conducted over two 24-hour periods reveal a diel variation in abundance, with generally higher densities at night and lower densities during the day time. A vertical density gradient also existed with higher densities near the surface, intermediate densities at the middle depth, and lowest densities at the bottom.

It was concluded that the AFB was effective in reducing entrainment of fish eggs and larvae during the early part of the study period (June 18 – July 13) by 76%. By the end of the study period, however, entrainment between the protected and unprotected intakes was essentially equal, indicating that the AFB's integrity may have been compromised at some point during the evaluation.

System evaluations continued in 1999 and 2000. LMS (2001) evaluated various MLES components including in-field maintenance, monitoring of the automated air-burst system, AFB integrity, and performance of an industrial-strength zipper for joining sections. ASA (2001) conducted the biological assessment of the AFB for excluding ichthyoplankton. As with previous tests, Unit 3 was surrounded by the AFB while Unit 4 was used as a control.

It was concluded that all aspects of the MLES deployment, operation, and retrieval went well. Minimal operational issues were encountered. The fabric maintained its integrity and the air-burst system kept the MLES clean of sediment. Installation of the zippers allowed for easier maintenance and the zippers held up under severe weather conditions. Biological sampling revealed that the AFB reduced entrainment of fish eggs and larvae by 74% during the initial stages of the study. A total of 31,966 eggs and larvae were collected at the unprotected intake (Unit 4) and 8,438 at the protected intake (Unit 3). Striped bass (*Morone saxatilis*) was the most abundant species collected, comprising approximately 74% of the total collected (40,404). Post yolk-sac larvae were the most abundant life stage collected, comprising 63.4% of the total collected during this evaluation. After six weeks of operation, the level of protection began to decrease until there was no detectable difference in entrainment rates between the protected and unprotected intakes. This decrease in physical exclusion was attributed to a hole that developed in the AFB that went unnoticed during the final stages of the evaluation.

A full-scale AFB covering all operational intakes (Units 3, 4, and 5 were in operation; Units 1 and 2 were retired in 1996) was installed at the Lovett Generating Station in 2004 (Figure 7-4). The total flow rate with Units 3, 4, and 5 in operation was 1,027.6 m<sup>3</sup>/min (271,463 gpm; 605 cfs). Biological monitoring of this expanded AFB system was conducted by ASA between 2004 and 2006 (ASA 2004, 2006a, 2006b). Control samples were collected outside of the protected intake, while test samples were collected from inside. Simultaneous samples were collected

weekly from each sample station during the nighttime. Daytime samples were collected once per month. Samples were collected from three depths and pumped with a trash pump to a net/barrel sampling system. The plankton nets had a 505 µm mesh. Volumes of sampled water were recorded with a digital flow meter and were approximately 70 m<sup>3</sup>/min (18,500 gpm).

A total of 8,049 organisms were collected in the 382 samples during 2004 sampling. A reduction in entrainment of 73% was realized between the test and control stations. Approximately 91% of the organisms collected were larvae. Striped bass (*Morone saxatilis*) and bay anchovy (*Anchoa mitchilli*) larvae were the most abundant species collected, representing 35% and 34% of the total, respectively. The percent reduction in entrainment of striped bass and bay anchovy were 84% and 68%, respectively.

Impingement sampling was also conducted as part of the 2004 scope. During the first 48 hrs of the study, the traveling water screen collection baskets were checked hourly. For the remainder of the study, impingement collections were made once per day. A total of 15,950 organisms were collected in impingement samples. Blue crabs (*Callinectes sapidus*) comprised 72% of the total number of organisms collected, indicating that there is potential for organisms (especially blue crabs that were noted to be swimming near the surface at night) to circumvent the physical barrier provided by the AFB.

Entrainment sampling continued in 2005 and followed the same sampling protocol developed in 2004. A total of 1,830 organisms were collected in the 416 samples during the 2005 sampling. A total reduction in entrainment of 92% was realized between the test and control stations. Approximately 95% of the organisms collected were larvae. Striped bass (*Morone saxatilis*) and bay anchovy (*Anchoa mitchilli*) larvae were the most abundant species collected, representing 41% and 36% of the total, respectively. The percent reduction in entrainment of striped bass and bay anchovy was 93% and 90%, respectively.

Entrainment sampling continued in 2006, following the same sampling protocol used in the previous two years of sampling. A total of 4,246 organisms were collected in the 342 samples during the 2006 sampling. A total reduction in entrainment of 89% was realized between the test and control stations. Approximately 91% of the organisms collected were larvae. Bay anchovy and striped bass larvae were the most abundant species collected, representing 39% and 21% of the total, respectively. The percent reduction in entrainment of bay anchovy and striped bass were 89% and 90%, respectively.

Gunderboom, Inc. (2006) prepared a comprehensive report to address National Pollutant Discharge Elimination System (NPDES) permit concerns of the New York State Department of Environmental Conservation (NYSDEC). Included in the report is a description of the “Operations, Monitoring, Maintenance and Repair Protocol” (OMMR), which is used to assure the integrity and continued functionality of the MLES. The authors concluded that biological monitoring alone would not be reliable or timely enough to assess system compromises, MLES integrity, or optimization of entrainment exclusion. This indicates that at future installations, development of a comprehensive monitoring program would be necessary to ensure that any compromise of AFB system is identified before a drastic increase in organism entrainment occurs.

## ***Bethlehem Energy Center***

The Bethlehem Energy Center (BEC) is located on the Hudson River just south of Albany in Bethlehem, NY. A review of potential intake alternatives was undertaken in Public Service Enterprise Group's (PSEG's) permit application for the generating facility before its planned start-up in 2005. Based on available information provided by PSEG, NYSDEC required a combination of wet/dry cooling towers, 2-mm (0.08-in.) cylindrical wedgewire screens, and a seasonally-deployed AFB as the Best Technology Available (BTA) for reducing the entrainment and impingement of aquatic organisms at BEC.

Due to physical constraints imposed by the busy shipping channel in the river, an anchored floating deployment of the AFB was not possible. Instead, the AFB was designed to be deployed in a fixed-panel arrangement in front of the cooling water intake structure. The AOS of the AFB fabric was 0.4 mm (0.02 in.) and had a designed through-fabric flow rate of less than 15.2 cm/s (0.5 ft/s).

With the intake technologies in operation at the BEC, the intake should have been very protective of all life stages of aquatic organisms; however, no biological data are available on the effectiveness on the AFB at the BEC at this time. Shortly after installation, the fixed panel deployment experienced significant failures most likely due to boat-generated waves associated with commercial shipping traffic. Under repetitive wave action, the fabric is alternately stressed inward contributing to fabric stretch and outward (due to backflow) onto the fabric support frames causing abrasion. Prolonged exposure to wave action is expected as the cause of fabric failure. In addition, consideration of wave action is important for design of the automatic airburst system that is activated by preset pressure differentials. A low differential water level set-point could activate the airburst on a very frequent basis. A high differential set-point would allow more debris and biofouling to accumulate on the fabric prior to airburst.

A wave-attenuating bar rack was subsequently proposed and piloted in front of the fixed-panel AFB at BEC. Though observational data indicate that it may have been successful in decreasing the impact of waves, a full-scale bar rack in front of the AFB would significantly decrease the ambient sweeping velocity of the river which is critical to the proper flushing of debris after airbursting of the fabric occurs. The AFB has subsequently been removed from the BEC site.

## **Case Studies – Field Evaluations**

### ***Pisces***

Henderson et al. (2001) conducted an evaluation of the biofouling of the AFB in a field setting. The objectives of the study were to determine the effects of biofouling on the flow distribution and filtering capacity of the AFB fabric and to characterize the biofouling community. The evaluation was conducted at the Bowline Generating Station in Bowline Pond on the Hudson River. Five-inch by 10.2 cm (4-inch) pieces of AFB were hung at 0.9, 2.7, and 4.6 m (3, 9, and 15 ft) depths from a boom in Bowline Pond. Some pieces were air-burst backwashed, while others remained static. The pieces of AFB were removed from the water on days 11, 20, and 29 for visual inspection, qualitative assessment of the biofouling community, permeability testing, and microbiological assay.

Results indicated that there was a significant difference in permeability among the three depths tested. In the no flow/no air burst treatments, there was a significant decrease in permeability over time. There was no change in permeability after 11 days, a 49% decrease in permeability after 20 days, and a 62% decrease in permeability after 29 days (Figure 7-5). In the treatments exposed to flow and airbursting, there was an even greater reduction in permeability. After 29 days, the flow was reduced to 4% that of clean fabric. The authors linked the decrease in permeability to the development of a diverse biofouling community. Additionally, it was hypothesized that the biofouling community was comprised of a number of potentially predatory species that could prey upon the eggs and larvae occurring near the AFB.



**Figure 7-5**  
Appearance of AFB pieces after 11, 20 and 29 days of exposure (moving from left to right) to water in Bowline Pond at a depth of 3 ft (Henderson et al. 2001).

## Case Studies – Laboratory Evaluations

Laboratory testing of the AFB is limited to two studies. The first was conducted by NYSDEC in 2001 (Radle 2001) and the second by Alden Research Laboratory in 2002 (EPRI 2004).

### **NYSDEC**

A small-scale laboratory study was conducted by NYSDEC to evaluate the survival of American shad (*Alosa sapidissima*) eggs impinged on AFB and to observe the swimming behavior of American shad larvae in the laboratory at a typical AFB approach velocity. For the impingement survival trials, eggs were placed in a hatching jar that had a disc of AFB mounted on one end (Figure 7-6). Uni-directional flow was initiated such that all eggs were impinged on the AFB surface. Eggs were impinged for 1, 2, or 4 hrs and then held for 24 hrs to assess latent mortality. Swimming observations of day-old larvae were conducted in a 0.3- by 1.1-m (1- by 3.5-ft) test channel with a piece of AFB at the downstream end. Flow in the channel was such that the through-*AFB* velocity was 5 gpm/ft<sup>2</sup>.



**Figure 7-6**  
**Hatching jars used in American shad egg impingement trials at the New York State Department of Environmental Conservation (NYSDEC) (photo courtesy Ed Radle, NYSDEC).**

The results of this laboratory evaluation indicate that impingement of American shad eggs on the AFB fabric did not significantly affect survival. Additionally, since the impinged eggs were easily freed from the AFB after the cessation of flow, the author concluded that the automatic airburst system could be expected to efficiently dislodge eggs in the field. Results of the swimming experiments indicate that day-old American shad larvae were capable of avoiding impingement on the AFB fabric withdrawing flow at a rate of 5 gpm/ft<sup>2</sup>.

### ***Electric Power Research Institute***

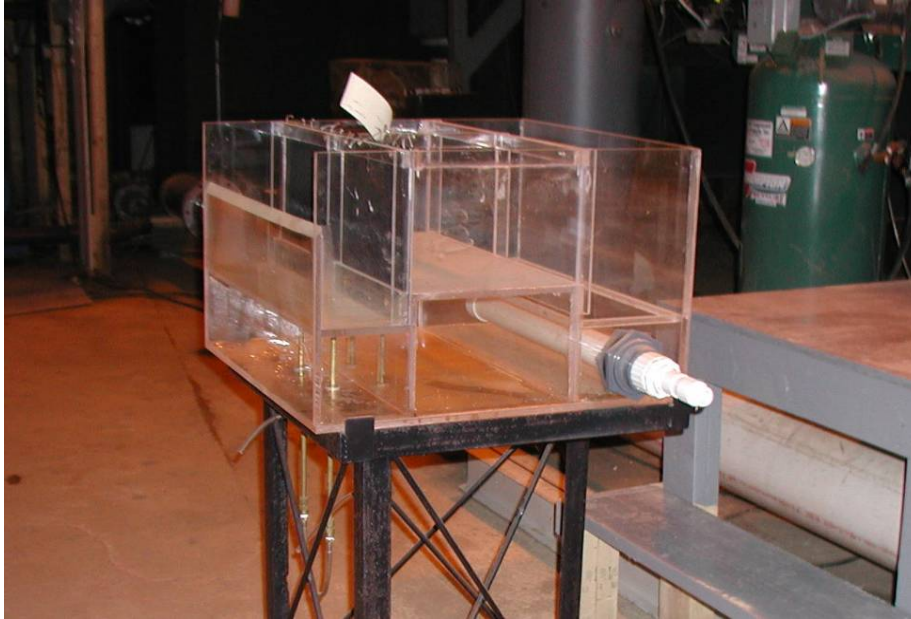
This laboratory evaluation was sponsored by the Electric Power Research Institute (EPRI 2004, Black et al. 2008) in order to evaluate the engineering and biological performance of a relatively new intake protection technology. This evaluation had two primary objectives. First was to investigate the engineering performance of the AFB when subject to physical forces common at CWIS. Second was to investigate the biological effectiveness of the AFB in reducing impingement mortality and entrainment of fish eggs and larvae.

The engineering portion of the evaluation was designed to focus on determining the AOS of AFB fabrics with three different perforation sizes (0.5, 1.0, and 1.5 mm [0.02, 0.04, and 0.06 in.]), determining the headloss coefficients for AFBs with these perforation sizes, determining the relationship between headloss and debris loading, and determining the effectiveness of the airburst system in cleaning the AFB.

Headloss and debris loading testing was conducted in a small acrylic test flume to develop a headloss coefficient (Figure 7-7). Investigation of the effects of ambient sweeping currents on the headloss of the various fabrics was conducted in a large test flume (Figure 7-8). Four simulated AFB intake configurations were evaluated in this study:

- the bottom portion of a floating anchored AFB oriented parallel to the ambient flow
- the middle or top portion of a floating, anchored AFB oriented parallel to the ambient flow
- the corner anchor point of a floating anchored AFB with the boom oriented at 45 degrees to the ambient flow
- a sloped fixed-panel AFB oriented parallel to the ambient flow





**Figure 7-7**  
Small test flume used in headloss and debris load testing (EPRI 2004).



**Figure 7-8**  
Large flume used in the investigation of the effects of ambient sweeping currents on headloss. AFB is installed to simulate the bottom portion of a floating anchored deployment oriented parallel to the ambient flow (EPRI 2004).



Two intake flow rates (10 gpm/ft<sup>2</sup> and 20 gpm/ft<sup>2</sup>) and two ambient sweeping velocities (7.62 and 30.5 cm/s [0.25 and 1.0 ft/s]) were tested during the engineering evaluation. Airburst testing was conducted in the large flume and evaluated the effectiveness of the airburst system in clearing the AFB after 85% blockage with simulated debris (Mylar sheets).

Biological evaluation of the AFB was conducted in a recirculating testing facility comprised of 14 small acrylic test flumes (Figure 7-9). Each small flume contained 5 individual testing channels with AFB covering the downstream end of each channel. The two objectives of the biological testing were to determine the effect of flow rate and perforation size on the survival and retention of eggs and larvae. Flow rates tested during the biological evaluation included 0, 10, and 20 gpm/ft<sup>2</sup>. Perforation sizes of 0.5, 1.0, and 1.5 mm were used in the biological testing as well. Species tested during this study included common carp (*Cyprinus carpio*), rainbow smelt (*Osmerus mordax*), striped bass (*Morone saxatilis*), bluegill (*Lepomis macrochirus*), yellow perch (*Perca flavescens*), walleye (*Sander vitreus*), and white sucker (*Catostomus commersonii*). Trials were run for 6 hrs and post-test fish were held for 48 hrs to assess latent mortality.



**Figure 7-9**  
**Biological testing facility comprised of 14 small acrylic test flumes (EPRI 2004)**

Results of the AOS study indicated that the measured AOS in the lab were not significantly different from the nominal perforation sizes of the fabrics supplied. Engineering evaluation indicated that the headloss across the various fabrics is small, between 0 and 0.2 ft for flow rates ranging between 0 and 20 gpm/ft<sup>2</sup>. After reaching 75% blocked, however, a large increase in loading from increasing headloss occurs in a short period of time. Results of the testing of the AFB in the large flume demonstrated that it is best to deploy AFB where ambient sweeping velocities are sufficient to carry debris away after airbursting occurs. Airburst testing indicated that the AFB would be adequately cleaned after one to three airburst cycles.

Results of the biological evaluation indicated that, for the most part, neither perforation size nor flow rate significantly affected survival. Retention decreased significantly with increases in perforation size and flow rate. The relationship between perforation size, flow rate, and retention is based on the morphology of the species interacting with the AFB and is therefore very species-specific.



# 8

## POROUS DIKES

### Introduction

Porous dikes, which allow water to pass while preventing fish passage, have been shown to be effective on an experimental basis and at a limited number of CWISs. However, entrainable organisms with limited swimming ability will generally be trapped in the porous medium or entrained into the pump flow.

Results of laboratory and pilot studies, as well as full scale CWIS applications have indicated that these dikes can be effective in preventing passage of juvenile and adult fish by eliciting a behavioral avoidance response. However, entrainable organisms with limited swimming ability will generally be trapped in the porous medium or entrained into the pump flow.

In addition to the case studies provided below, other power generators are looking at porous dikes as a fish protection alternative. For example, a technical and economic feasibility study was conducted for Northern Indiana Public Service Company (NIPSCO) to evaluate the replacement of the existing intake crib structure at the Bailly Generating Station (BGS) with a new porous dike cooling water intake structure (CWIS) as fish impingement and entrainment control (W.F. Baird 2012).

### Case Studies

#### ***Wisconsin Electric Power Plants – Field Test and CWIS Application***

The effectiveness of porous dike and leaky dam systems in minimizing impingement and entrainment at power plant intakes was assessed from monitoring studies conducted by the Wisconsin Electric Power Company (Michaud 1981). The study design, sampling methods, and impingement and entrainment results by species appear in Michaud (1981). The study also reviewed operation, maintenance, and reliability concerns of using these intake designs and provided alternative design suggestions.

The results of this study indicated that, for several species of adult and larval fish, the impingement and entrainment rates of the porous dike and leaky dam structures were lower than the rates at nearby onshore intake structures. The accuracy of these results was limited by the variable densities of Lake Michigan ichthyoplankton populations. Data interpretation also was limited by differences in operating characteristics and environmental conditions among the four plants. In spite of these limitations, the low approach velocity and the physical barrier to fish encroachment afforded by the leaky dam were found to be environmentally preferable to other systems. Although the lower entrainment rates could not be attributed per se to these features, the study's authors considered it intuitively reasonable that such a structure would result in lower entrainment of motile larvae.

The lower impingement rates observed for large salmonids at the Point Beach Nuclear Plant were thought to be due in part to the intake design, but for alewife (*Alosa pseudoharengus*),

spottail shiner (*Notropis hudsonius*), emerald shiner (*Notropis atherinoides*), and trout-perch (*Percopsis omiscomaycus*), the different rates probably reflected differences in area fish densities. The high degrees of spatial and temporal variability in the alewife population precluded statistical comparisons among the plants. The density of ichthyoplankton was generally higher in the lake samples than in the cooling water, indicating either disproportionate entrainment in relation to their abundance in the lake or a disparity in sampling efficiency between the submersible pumps and the plankton nets. Because of this variability, guidelines for the design and location of intakes could not be based on impingement rates alone. The study's authors recommended that variations in month-to-month operating modes among the four plants also be considered when drawing conclusions from this study.

In 2001, the porous dike at Point Beach was modified by replacing half of the structure with an open grate/steel plate. Consequently, water is currently withdrawn through both the remaining half of the dike and the newly added open grate/steel plate. In addition, a high frequency sonic deterrent system (125 kHz) was added to counter the high densities of alewife occurring near the intakes during the spring.

WE Energy built a porous dike system at Port Washington on Lake Michigan during repowering. A two-year biological (impingement and entrainment monitoring) and operational performance evaluation study commenced in January 2009 and was completed in December 2010. Impingement rates after the installation of the porous dike were 92-99% lower than pre-installation levels (Lee 2011). Similarly, egg entrainment was reduced by around 96%. Total larval entrainment increased, but this was driven by the invasive round goby, which constituted more than 70% of larval entrainment after the dike was installed as compared to about 25% of pre-construction larval entrainment (Lee 2011). Species entrained included: alewife, gizzard shad (*Dorosoma cepedianum*), smelt (*Osmerus* spp.), spottail shiner, sticklebacks (*Gasterosteus* spp.), gobies (Family Gobiidae), and trout and salmon (Family Salmonidae).

### **Brayton Point – Laboratory and Field Trials**

Field and laboratory studies using marine fish species also indicated that a rock porous dike is a barrier to juveniles and adults, and that it may be a physical or behavioral barrier to larval fish (Ketschke 1981). In the laboratory studies, swimming orientation and avoidance response of five larval species and ten juvenile and adults species was tested in a T-shaped flume with a rock gabion of 20-cm (8-in.) stones. The laboratory flume was designed to provide a unidirectional cross current in the forward chamber and to allow withdrawal of all or part of the flow through the rock gabion into the main chamber. The threshold for avoidance response was defined as the ability to detect and swim against a withdrawal current velocity of 0.01 m/sec (0.1 ft/sec). The response did not have to result in actual entrainment avoidance.

All of the species tested as larvae, with the exception of windowpane flounder, exhibited an upstream orientation response. Atlantic menhaden (*Brevoortia tyrannus*) and stickleback showed a strong avoidance response at an early larval stage and an improved swimming ability with increased size. Winter flounder (*Pseudopleuronectes americanus*) and Northern pipefish (*Syngnathus fuscus*) were passive drifters during the early larval stage and showed little or no swimming response throughout the larval period. During their later larval stage, winter flounder often sought the bottom of the flume in response to currents.

Most species of juvenile and adult fish showed at least partial entrainment avoidance in the laboratory flume and showed little or no attraction to the gabion. However, mummichog (*Fundulus heteroclitus*) and cunner (*Tautoglabrus adspersus*) were strongly attracted to the gabion. The cunner took up residence in the gabion but were not actually entrained.

Prior to field tests conducted at New England Power Company's porous dike test facility, a hydraulic laboratory study on porous dikes (Alden 1976) was conducted at Alden Research Laboratory. Conclusions from this study indicated that head loss is affected most by stone angularity and to a lesser degree by porosity; that if shape and porosity are constant, stone size is not important; that the stability of the downstream dike face is important as large head loss can compromise structural integrity; and that the velocity distribution on the downstream side of the dike can be highly irregular due to variations in porosity.

Subsequent field tests were conducted at the porous dike test facility at Brayton Point Station, which is located on the Narragansett Bay in Massachusetts. The reinforced concrete-and-steel dike was 18.3 by 6.4 by 6.1 m (60 by 21 by 20 ft) deep, with a three-cell chamber open at the top and front to hold the gabions. Water was drawn through the dike by a 1.2-m (4-ft) diameter axial flow pump, which had a capacity of 2.9 m<sup>3</sup>/sec (103.8 cfs), and the flow was regulated by baffles. The first cell of the chamber had two rows of gabions filled with 7.6 cm (3 in.) stones to form a wall 1.8 m (6 ft) wide, 1.8 m (6 ft) thick, and approximately 4 m (13 ft) high. The third cell had three rows of gabions filled with 20.3-cm (8-in.) stones to form a 1.8 m (6 ft) wide, 2.7-m (9-ft) thick wall about 4 m (13 ft) high. The middle cell was sealed and was not in use.

In the field studies, naturally occurring ichthyoplankton were sampled via pumps from locations upstream and downstream of the dike to determine differences in larval fish abundance related to each of the gabion types. If the downstream densities were lower than the upstream densities, it was assumed that avoidance, filtration, or cropping had occurred. In addition to naturally occurring ichthyoplankton, groups of seven finfish species ( $n = 2,000+$ ) were fin-clipped and impounded upstream of the gabions for periods of 24 to 48 hrs. The numbers of fish caught by seining downstream of the gabions were counted as entrained.

Significant differences between upstream and downstream larval densities were seen for bay anchovy and for winter flounder. Field test data for larval bay anchovy with 7.6 cm (3 in.) stone gabions and for other larval species were not available. With the 20.3 cm (8 in.) stones, the density of bay anchovy (*Anchoa mitchilli*) was reduced by 94 to 99% and winter flounder was reduced by 23 to 87%. The differences in winter flounder density became larger and more significant as the season progressed. Similar results were obtained for winter flounder with 7.6 cm (3 in.) stones, except that the differences in density were not noticeable until later in the season. Entrainment avoidance was 100% for all juvenile and adult finfish species, which strongly indicated that these fish would not or could not pass through either a 7.6 cm (3 in.) or a 20.3-cm (8-in.) rock porous dike.

### **Laboratory Evaluation – Kinetics**

A laboratory evaluation was conducted to determine the optimum pipe diameter for the design of a pipe-based dike. Specifically, this study was undertaken to investigate fish perception and reaction to various pipe diameters and configurations (Patrick et al. 2006a).

Trials were conducted in a 7- by 7-m (23- by 23-ft) tank with a 1.5 m (4.9 m) water depth. Circular flow (0.15 m/sec [0.5 ft/sec]) ensured that fish would interact with the experimental pipe array. Seven pipe configurations were tested: straight pipes with openings of 0.3, 0.6, and 0.9 m (1, 2, and 3 ft); cone-shaped pipes constricting from 0.9 to 0.3 m (3 to 1 ft) and 0.6 to 0.3 m (2 to 1 ft); as well as cone-shaped pipes expanding from 0.9 to 0.3 m (1 to 3 ft) and 0.6 to 0.3 m (1 to 2 ft). Groups of 25 fish were held in a caged acclimation area within the test facility prior to release. An overhead camera captured fish behavior as they encountered the pipe array. Counts were made of fish position (0.6 or 1.2 m [2 or 4 ft] away from the pipe array, or in the pipes openings).

General observations revealed that schooling species avoided confined spaces. Overall passage deterrence was over 70% for all species. The 0.3 and 0.6 m (1 and 2-ft) pipe openings provided higher retention of fish upstream of the barrier than the 0.9-m (3-ft) pipe openings. Regarding the cone-shaped pipes, better performance was realized with those expanding from a small opening to a larger opening versus those constricting from a large to a smaller opening (Patrick et al. 2006a). Species evaluated included: alewife, gizzard shad, white sucker (*Catostomus commersonii*), brown bullhead (*Ameiurus nebulosus*), and shiner species (Family Cyprinidae)0

### **Laboratory Evaluation – Consumers Power**

Consumers Power Company sponsored a laboratory investigation in 1972 to determine the practicality of a rock barrier permeable dike as a fish barrier (Bell et al. 1974). The investigation was undertaken in two phases: the first was to determine a method of predicting hydraulic performance (head loss) or acceptable void size in such a barrier, and the second was to test the behavior of fish when encountering such a barrier.

Tests were conducted in an experimental flume. The three samples tested were all well-rounded stream gravels, with nominal maximum diameters of 3.8, 7.6, and 15.2 cm (1.5, 3.0, and 5.0 in.), respectively.

In the first phase of testing, hydraulic performance experiments were conducted to determine the variation of the Fanning friction factor,  $f$  (commonly used in porous media flow), with the Reynolds number over the range of test variables possible in the laboratory setup. Tests were conducted in 3 m (10 ft) wide rectangular channels. Gravel samples were contained in commercial gabions, lined with appropriate wire mesh to retain all gravel within the gabion.

In the second phase of testing, the examination of the rock barrier as a screen was accomplished by placing fish of various species and sizes upstream under velocity conditions approximating their normal swimming cruising speeds (range: 0.04 to 0.09 m/sec [0.13 to 0.28 ft/sec]). Eleven tests were performed in the flume with rainbow trout (*Oncorhynchus mykiss*) (2.8 to 5.8 cm [1.1 to 2.3 in.]), Chinook salmon (*Oncorhynchus tshawytscha*) (7.1 to 8.1 cm [2.8 to 3.2 in.]), bluegill (*Lepomis macrochirus*) (3.0 cm [1.19 in.]), largemouth bass (*Micropterus salmoides*) (4.14 cm [1.63 in.]), bullheads (*Ameiurus* spp.) (5.1 cm [2.0 in.]) and stickleback (*Gasterosteus* spp.) ( $n = 1$ , no length data).

Rainbow trout moved into and through the dike after 96 hrs in one test. In another test, the bluegill, bass, and bullheads placed below the rock barrier did not penetrate it upstream in a period of 24 hrs. In two tests with young rainbow trout, and one with the warm water fish,

illuminating either the downstream or upstream face of the barrier appeared to have little or no effect on the effectiveness of stopping fish at the rock barrier.

As was expected, a few of the fish were trapped in the rock barrier. Rainbow trout stayed in the area upstream of the rock barrier when they reached a size at which they did not penetrate the barrier. The barrier was effective when the critical head depth range was exceeded. Observations showed that the fish were usually entrained through the barrier during the darkness hrs when it is normal for them to seek the protection of a river bank.





# 9

## FISH PUMPS

### Introduction

Several pumps have demonstrated an ability to transfer fish with little or no mortality. Recent results using new designs indicate that pumps are available that induce little injury and mortality. The screw-impeller pump appears to offer a potentially effective means of transporting larval, juvenile, and adult fishes with low mortality. As evidenced in some of the following case studies, even fragile species such as gizzard shad (at the Monroe Power Plant) and rainbow smelt (at the Darlington Nuclear Generating Station) have been pumped with low mortality.

### Case Studies – CWIS Application

#### *Darlington Nuclear Generating Station*

A series of studies were conducted to evaluate various fish protection technologies at Ontario Hydro's Darlington Nuclear Generating Station on Lake Ontario (Christie 1990). Laboratory tests were conducted for a Hidrostral impeller type pump, which was chosen for evaluation based on earlier data demonstrating its potential to transport fish with minimal injury.

Two Hidrostral pump models were used in this laboratory evaluation. Pump model H5F which had an intake measuring 10 cm (3.9 in.) in diameter and a discharge measuring 25 cm (9.8 in.) in diameter was used for tests with eels (30 to 50 cm [11.8 to 19.7 in] TL). Pump model H5 which had a smaller intake measuring 7.6 cm (3 in.) in diameter and a discharge measuring 25.4 cm (10 in.) in diameter was used for tests with rainbow trout (12 to 20 cm [4.7 to 7.9 in.]), yellow perch (10 to 20 cm [3.9 to 7.9 in.]), alewife (10 to 16 cm [3.9 to 6.3 in.]), and rainbow smelt (8 to 12 cm [3.1 to 4.7 in.]). Two lengths of discharge pipes measuring 2.1 and 15.5 m (6.9 and 50.9 ft) generated two velocities of 1.4 and 1.8 m/sec (4.6 and 5.9 ft/sec) respectively. Variables for eel tests included three pump speeds of 890, 1,043, and 1,204 rpm and four eel densities ranging from 13 to 85 individuals per 100 L of water. Variables for the other four lake fish species included four pump speeds of 436, 604, 944, and 1,163 rpm and two fish densities of 14 and 55 individuals per cubic meter volume.

Forty-eight-hour survival was recorded for each species tested. Average eel survival was 98% across all test conditions. Pump speeds and eel densities had no significant effect on survival. Average lake fish survival was 93% across all test conditions. Average survivals of 99, 94, 91, and 90% were experienced by rainbow trout, yellow perch, alewife, and rainbow smelt, respectively. Pump speed was inversely related to survival with the highest average survival (96%) occurring at the two lowest pump speeds (436 and 604 rpm) and the lowest average survival (91%) occurring at the two highest pump speeds (944 and 1,135 rpm).

Evaluation of injuries associated with passage through the pump system revealed that an average of 5% of eels sustained only bruising across all test conditions. The other lake fish species experienced a wider range of injuries including hemorrhages, bruises, cuts, and scale loss. Pump speed and frequency of injury were shown to be directly related to injury averages for all species,

rising from 2.2% for 436 rpm to 9.4% for 604 rpm to 13.5% for 944 rpm to 27.7% for 1,135 rpm. These results led the author to designate a pump speed of 600 to 900 rpm for the efficient design of a fish pump system.

Further laboratory analyses were conducted on the efficacy of mercury lights used alone and in concert with strobe lights, electroshocking, and air bubble curtains in increasing attraction to the fish pump intake. Mercury lights alone were shown to effectively increase the capture efficiency of the pump intake. Three-hour trials were conducted with rainbow smelt and alewife to discern the fish intake efficiency of the pump alone and in combination with mercury lights. The pump capture efficiency increased from 6.7% to 14.0% for rainbow smelt and from 19% to 61.3% for alewife with the use of mercury light.

At the Thunder Bay Thermal Generating Station on Lake Superior, a model L12FS Hidrostral fish pump is used at the cooling water intake structure. Other fish protection technologies employed at this site include trash racks and modified traveling water screens with fish buckets that direct collected fish to a sump where the fish pump (set at 650 rpm) transports them to a 45-cm (17.7 in.) diameter return pipe that measures about 500 m (1,640.4 ft) long. A mark-recapture study resulted in recovery and return efficiencies of 85% for both the pump and return pipe.

Another study of a fish pumping system evaluated the efficiencies of different pump intake designs in capturing fish. At the Bruce A. Nuclear Generating Station on Lake Huron, three different intakes were evaluated: a 15-cm (5.9 in.) diameter PVC pipe, a 15-cm (5.9 in.) diameter clear acrylic pipe, and a cone shaped PVC pipe. The velocities associated with each intake design were 0.39 m/sec (1.3 ft/sec) for the cone shaped PVC and 3.8 m/sec (12.8 ft/sec) for the other two. The PVC and cone shaped PVC had a combined average capture rate of 1.2 fish/hr, while the clear acrylic intake averaged approximately 600 fish/hr. This discrepancy has been attributed to visual avoidance of the PVC. Furthermore, capture rates of 6,000 fish per hour during the day and 3,000 fish per hour during the night were reached by extending the length of the intake pipe and illuminating it with mercury lighting.

### ***Sioux Power Plant***

Union Electric Company (1982) conducted an evaluation of a fish pump that was installed in 1980 at its Sioux Power Plant. Sioux is a coal fired thermal generating plant located on the Mississippi River just north of St. Louis. Cooling water is withdrawn through a 487.7-m (1,600-ft) long canal into the two 500-MW units. At normal low water levels, the intake velocity in front of the trash rack is 0.43 m/sec (1.4 ft/sec) and drops to 0.40 m/sec (1.3 ft/sec) in front of the screens.

The Sioux intake consists of four screenwells, each containing a 7.6-cm (3-in.) spaced trash rack and a vertical traveling screen to remove debris. The screens can be rotated at two speeds (1.5 or 6.1 m/min [5 or 20 ft/min]). Trash and other debris (including fish) are removed by spray wash and delivered back to the river via a discharge pipe.

The fish pump collectors face the screens and cover the entire width of the screenwells. Fish are pumped with Hidrostral type F pumps, which are capable of pumping 1,678 gpm against 11 m (36 ft) of head at 900 rpm. Collected fish are returned via a 518.2 m (1,700-ft) long pipe back to the river to a discharge point 3 m (10 ft) below the surface.

A total of 10, 24-hr samples were collected during the yearlong study. The immediate and latent effects of pump passage were determined by holding fish for 24 hrs. Fish were collected by diverting flow from the return pipe to collection tanks where fish could be held for monitoring latent mortality. Similar sampling and holding protocols were followed for fish impinged on the traveling screens (i.e., impinged fish were diverted from their return trough and held for 24-hour latent mortality observation). After 24 hrs, the fish were weighed, measured, and sorted into groups of live, dead, and injured.

Additional tests were run to determine the extent of injury imparted by the pump. These samples consisted of making a 1-hr collection and then examining their condition immediately. Immediate assessment of the fish condition afforded the opportunity of enumerating numbers of fish dead or moribund before passage through the pump.

Data were used to calculate pumping efficiency (number pumped / number pumped and impinged), survival efficiency (number alive and uninjured / number pumped), and net survival efficiency (number alive and uninjured / number pumped and impinged).

A total of 35,398 fish representing 30 species were collected. Forty-six percent of these were collected by the pumps and 54 % were collected off the screens. Gizzard shad and freshwater drum were the most abundantly collected species comprising 93% and 5.8% of the total, respectively. Pumping, survival, and net survival efficiencies for each species are presented in Table 9-1.

**Table 9-1**  
**Species specific results of the Sioux fish return system 24-hr pumping and 24-hr holding tests, March through December, 1981 (Union Electric Company 1982).**

| Common Name           | Total Number of Fish Pumped And Impinged | Pumping Efficiency (%) | Survival (24 Hr) Efficiency (%) | Net Survival Efficiency (%) |
|-----------------------|------------------------------------------|------------------------|---------------------------------|-----------------------------|
| shovelnose sturgeon   | 1                                        | 0                      | --                              | 0                           |
| paddlefish            | 8                                        | 38                     | 33                              | 13                          |
| shortnose gar         | 6                                        | 17                     | 100                             | 17                          |
| longnose gar          | 1                                        | 100                    | 0                               | 0                           |
| gizzard shad          | 32,923                                   | 46                     | 82                              | 38                          |
| mooneye               | 3                                        | 0                      | --                              | 0                           |
| goldeye               | 4                                        | 25                     | 100                             | 25                          |
| emeral shiner         | 2                                        | 100                    | 100                             | 100                         |
| golden shiner         | 1                                        | 100                    | 100                             | 100                         |
| bullhead minnow       | 1                                        | 0                      | --                              | 0                           |
| carp                  | 92                                       | 75                     | 87                              | 65                          |
| river carpsucker      | 7                                        | 71                     | 100                             | 71                          |
| shorthead redhorse    | 6                                        | 100                    | 100                             | 100                         |
| white sucker          | 1                                        | 100                    | 100                             | 100                         |
| smallmouth buffalo    | 2                                        | 50                     | 100                             | 50                          |
| bigmouth buffalo      | 1                                        | 100                    | 100                             | 100                         |
| channel catfish       | 95                                       | 59                     | 84                              | 50                          |
| blue catfish          | 13                                       | 62                     | 100                             | 62                          |
| black bullhead        | 8                                        | 88                     | 100                             | 88                          |
| flathead catfish      | 4                                        | 100                    | 75                              | 75                          |
| white bass            | 131                                      | 48                     | 76                              | 37                          |
| green sunfish         | 4                                        | 75                     | 100                             | 75                          |
| warmouth              | 2                                        | 100                    | 100                             | 100                         |
| orangespotted sunfish | 3                                        | 0                      | --                              | 0                           |
| bluegill              | 33                                       | 76                     | 84                              | 64                          |
| largemouth bass       | 2                                        | 100                    | 100                             | 100                         |
| white crappie         | 23                                       | 48                     | 91                              | 44                          |
| black crappie         | 2                                        | 100                    | 100                             | 100                         |
| walleye               | 2                                        | 50                     | 100                             | 50                          |
| freshwater drum       | 2,037                                    | 36                     | 84                              | 30                          |
| Total <sup>3</sup>    | 35,398                                   | Mean = 46              | Mean = 82                       | Mean = 37                   |

<sup>3</sup> Total presented in Table 1 (Union Electric Company 1982) does not match the sum of the individual species (n=35,418). The source of this discrepancy is unknown.

The average survival efficiency for all species was 82% for pumped fish. While some species displayed very good survival rates, sample sizes were small lending little power to the data. The average net survival efficiency was 37% for all species. By season, net survival was highest in the fall (48%) and lowest in the winter (2%) (Table 9-2).

**Table 9-2**  
**Sioux fish return system 24-hour pumping and 24-hr holding tests, March through December, 1981 (Union Electric Company 1982).**

| Date           | No. of Operating Pumps | No. of Fish in Impingement Baskets | # of Fish in Collection Tank After 24-hr Holding Period |            |          | Collection Tank Total | Total No. of Fish Sampled | % Impinged  | Pumped      |             |            | % Pumping Efficiency | % Net Survival Efficiency |
|----------------|------------------------|------------------------------------|---------------------------------------------------------|------------|----------|-----------------------|---------------------------|-------------|-------------|-------------|------------|----------------------|---------------------------|
|                |                        |                                    | Live                                                    | Dead       | Injured  |                       |                           |             | % Live      | % Dead      | % Injured  |                      |                           |
| 3/23/1981      | 2                      | 1,593                              | 272                                                     | 189        | 4        | 465                   | 2,058                     | 77.4        | 58.5        | 40.6        | 0.9        | 22.6                 | 13.2                      |
| 3/30/1981      | 2                      | 5,028                              | 222                                                     | 73         | 1        | 296                   | 5,324                     | 94.4        | 75          | 24.7        | 0.3        | 5.6                  | 4.2                       |
| 4/6/1981       | 1                      | 478                                | 176                                                     | 45         | 1        | 222                   | 700                       | 68.3        | 79.3        | 20.3        | 0.4        | 31.7                 | 25.1                      |
| 5/5/1981       | 2                      | 61                                 | 79                                                      | 18         | 3        | 100                   | 161                       | 37.9        | 79          | 18          | 3          | 62.1                 | 49.1                      |
| 6/8/1981       | 1                      | 31                                 | 37                                                      | 9          | 4        | 50                    | 81                        | 38.3        | 74          | 18          | 8          | 61.7                 | 45.7                      |
| 7/20/1981      | 3                      | 1,431                              | 888                                                     | 171        | 0        | 1,059                 | 2,490                     | 57.5        | 83.9        | 16.1        | 0          | 42.5                 | 35.7                      |
| 8/26/1981      | 3                      | 399                                | 315                                                     | 74         | 1        | 390                   | 789                       | 50.6        | 80.8        | 19          | 0.2        | 49.4                 | 39.9                      |
| 9/28/1981      | 3                      | 312                                | 86                                                      | 16         | 2        | 104                   | 416                       | 75          | 82.7        | 15.4        | 1.9        | 25                   | 20.7                      |
| 11/10/1981     | 3                      | 9,718                              | 11,161                                                  | 2,255      | 44       | 13,460                | 23,178                    | 42          | 83          | 17          | 0          | 58                   | 48                        |
| 12/16/1981     | 3                      | 195                                | 5                                                       | 21         | 0        | 26                    | 221                       | 88.2        | 19.2        | 80.8        | 3.9        | 11.8                 | 2.3                       |
| <b>Average</b> | <b>2.3</b>             | <b>1,925</b>                       | <b>1,325</b>                                            | <b>287</b> | <b>6</b> | <b>1,617</b>          | <b>3,542</b>              | <b>54.3</b> | <b>81.9</b> | <b>17.7</b> | <b>0.4</b> | <b>45.7</b>          | <b>37.4</b>               |

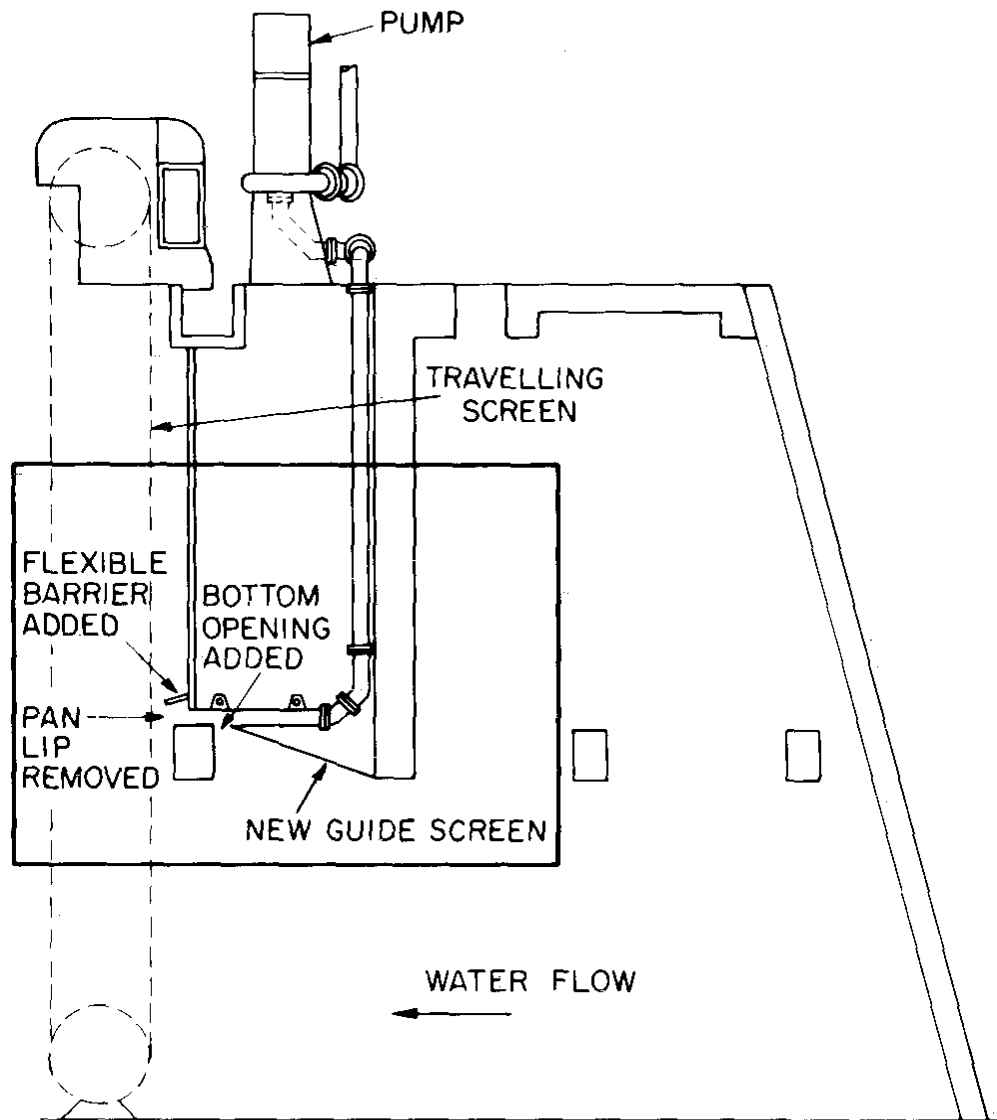
Results of the 1-hour samples revealed a relatively high immediate survival of 80%. It was concluded that the 19.5% dead were dead upon pumping. Another 0.5% of pumped fish were assessed as injured, indicating that the pumps were imparting very little physical stress on the fish. Gizzard shad, the most abundantly pumped fish, had a survival efficiency of 82%. Net survival efficiencies (pumped and impinged fish) for gizzard shad were 41% and 24% for fish measuring between 0–100 mm and 101–150 mm, respectively.

Overall, the net survival efficiency of the collective fish return system was 37% for all species. It was noted by the author that the net efficiencies for important game and commercial fish were considerably higher with most species, exceeding 50%. The author concludes that the fish return system at Sioux functions successfully in decreasing impingement.

### ***Monroe Power Plant***

Detroit Edison (1975) installed a complete fish pump and transportation system in all four units of the Monroe Power Plant following an extensive evaluation of the concept in two intake bays of the Unit 2 screenhouse.

The experimental fish pumping system, modeled after an operating system at the Contra Costa Power Plant in California, was installed in August 1973. The system consisted of two barrier screens, two collection pans, piping elements, and a volute pump (Figure 9-1). The collecting pans were located near the bottom of the existing skimmer walls directly in front of, and facing, the traveling screens. They were mounted horizontally and measured 3.7 m (12.8 ft) wide by 20.3 cm (8 in.) deep. The barrier screens were installed to prevent fish from penetrating the area above the collecting pans and behind the skimmer wall. The volute pump had a 0.5-m (1.7-ft) diameter impeller with two channels and was rated at a capacity ranging from 0.07 to 0.2 m<sup>3</sup>/sec (2.6 to 8.2 cfs). The piping system consisted of two 20.3-cm (8-in.) pipes, leading from each of the two collecting pans, which transitioned into a common 25.4-cm (10-in.) pipe connecting to the pump.



**Figure 9-1**  
**Monroe Power Plant section view of fish pump system (Detroit Edison 1975)**

During the experimental period, the pump discharged into a holding pool that measured 6.4 m (21 ft) in diameter and 1.2 m (4 ft) in depth (capacity of 37,850 L [10,000 gal]). After collection, live fish were transferred to holding tanks for observation and were ultimately transported by truck to Lake Erie for release.

After 4 months of operation, modifications were made to the pumping system to enhance collection efficiency. The bottom lip of the collecting pan was removed, and a flexible barrier was placed above the pan to guide fish into the collector (see Figure 9-1). To increase the size of the collecting pan opening, the horizontal barrier screens were relocated, and holes were cut in the bottom of the pan. In addition, two incandescent underwater lights were installed in the



collector cover to help attract fish to the pan. Modifications were also made to the piping system and holding pool in an attempt to reduce mortality in the pumping system.

A complete description of the biological studies conducted with the fish pumping system at Monroe is presented in separate reports (Detroit Edison 1975; Eisele and Malaric 1977). In brief, these studies showed that the pumping system can reduce existing impingement by more than 70%, and that latent mortality is low.

On the basis of these results, Detroit Edison backfitted all of the screenwell bays at Monroe with fish pumps that return fish to a discharge point in Lake Erie via a 81.2-cm (32-in.) diameter, 1,341-m (4,400-ft) long polyethylene pipe. In addition, the Missouri Department of Natural Resources accepted a fish pump system based on the Monroe design for Union Electric's Sioux Power Plant.

## **Case Studies – Water Diversion Applications**

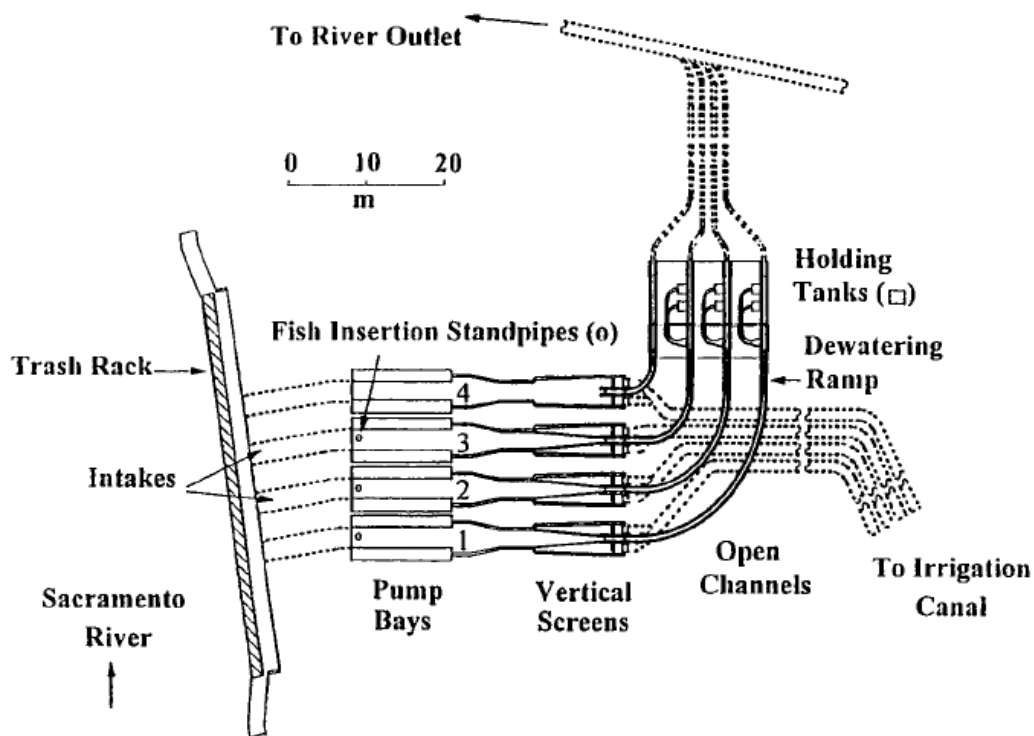
### ***Red Bluff Research Pumping Plant***

Evaluations of "fish friendly" pumps for possible use at the Red Bluff Diversion Dam (RBDD) were conducted at the Red Bluff Research Pumping Plant located adjacent to the diversion dam on the Sacramento River (Frizell et al. 1996; McNabb et al. 1998). The RBDD, which diverts water to the Tehama-Colusa irrigation canal system, affects both the upstream and downstream migrations of several species, including Chinook salmon. As described below, three pumps (two Archimedes and one Hidrostral helical) are being evaluated as part of ongoing research efforts to develop an effective method for protecting outmigrating fish at the diversion (Figure 9-2). The pump studies involve intensive fisheries and engineering evaluations. The design flow of each pump is 2.8 m<sup>3</sup>/sec (100 cfs) at an operating head of 5.5 m (18 ft). Vertical V-shaped screens with wedge-wire panels are used to guide fish to evaluation holding tanks and bypasses (similar to those we describe under Diversion Systems).

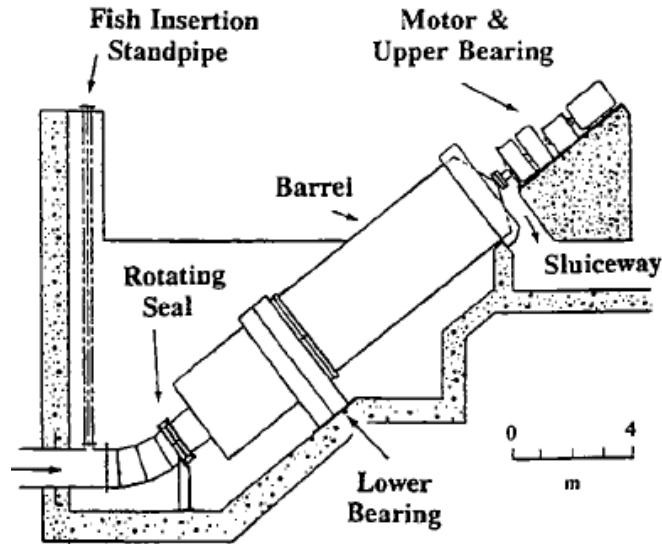
Initial exploratory tests of fish passage through the pumps were conducted in 1995 and 1996. The estimated survival rate for all fish collected was 96.2%. Passage survival has been estimated for naturally entrained fish and for fish released during mark-recapture experiments. A total of 2,281 entrained fish representing 20 species were collected during 29 sample events in 1995 and 1996. About half of the fish collected were juvenile Chinook salmon. Estimated injury rates for entrained Chinook salmon were between 0.6 and 1.2%. Mark-recapture experiments were conducted with hatchery-reared juvenile Chinook salmon that were almost all greater than 46 mm (1.8 in.) in length. Survival and injury rates of marked fish passing through the pump facilities were estimated by releasing them at different locations within system (i.e., pump intakes, pump outfalls). A total of 2,080 fish were released into the pump intakes during 65 experimental trials, and 1,725 fish were released into the bypass outfalls during 54 trials. The estimated pump-related direct mortality rate was less than 1%, and the estimated 96-hour mortality rate was approximately 1%. Estimated external injury rates were less than 1%.

Although the preliminary results indicated that the pump facilities were effective, no final recommendations with respect to the overall feasibility of using the pumps on a permanent basis were made. Other studies associated with predation, adult migration, and survival of fish under a wider range of environmental conditions are ongoing. Also, operational issues associated with the centrifugal (WEMCO) pump are being addressed.

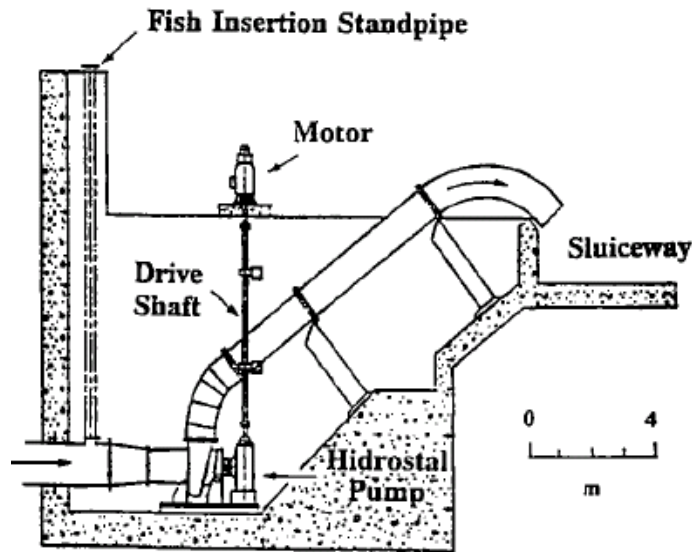
A subsequent side-by-side comparative evaluation of the Archimedes lift and the Hidrostal pump was conducted at the Red Bluff Research Pumping Plant on the Sacramento River. The plant's intake structure had a trash rack with vertical slats spaced 5 cm (1.96 in.) apart (Figure 9-2). There were four 1.22-m (4-ft) diameter intake pipes that open into four pumping bays. Bays 1 and 2 contained Archimedes lifts (Figure 9-3) measuring 11.58 m (38 ft) in length and 3.05 m (10 ft) in diameter, the barrels of which contained three internal flights. Bay 3 contained a Hidrostal pump (Figure 9-4) with an intake diameter of 0.91 m (3 ft) and a single vane impeller. The lift and pump were run at 26.5 and 350-375 rpm, respectively, to give each a discharge of 2.3 to 2.8 m<sup>3</sup>/sec (81.2 to 98.9 cfs). Water discharged by the lifts and pump traveled through a concrete sluiceway where approximately 90% of the water was removed via vertical wedgewire screening. The remaining 10% containing the debris and fish was diverted to a dewatering ramp where fish and debris were intercepted and diverted to holding tanks (McNabb et al. 2003).



**Figure 9-2**  
**Schematic of the Red Bluff Research Pumping Plant, Sacramento River, CA. Archimedes lifts were in pump bays 1 and 2. The Hidrostal pump was in bay 3, and bay 4 was empty. Dotted lines indicate underground portions of water intakes, the conveyance system for irrigation water, and the fish bypasses (McNabb et al. 2003).**



**Figure 9-3**  
 Cut-away perspective of Archimedes lifts in bays 1 and 2 of the Red Bluff Research Pumping Plant, Sacramento River, California. During operations, entrained fish were carried upward and discharged into a sluiceway that led downstream to the vertical screens shown in Figure 9-2 (McNabb et al. 2003).



**Figure 9-4**  
 Cut-away perspective of the Hidrostal pump in bay 3 of the Red Bluff Research Pumping Plant, Sacramento River, California. During operations entrained fish were carried upward and discharged into a sluiceway that led downstream to the vertical screens shown in Figure 9-2 (McNabb et al. 2003).

The hatchery reared juvenile Chinook salmon obtained from the Coleman National Fish Hatchery measured 34 to 74 mm (1.3 to 2.9 in) (fork length). Two releases were made simultaneously for each trial during this evaluation (27 paired trials using two Archimedes lifts, and 40 paired trials using one lift and one pump). Two groups of control fish were also released

per trial into the sluiceway downstream from the discharge pipes. Release of these four groups of fish took approximately 1 hr. All trials were conducted during darkness. Fish were collected from the holding tanks and held for 96 hrs to record latent mortality. Fish not collected were assumed to be alive and holding somewhere in the system. Only 3.5% of control fish and 4.2% of treatment fish went uncollected during the whole evaluation.

Recovered fish were assessed for immediate mortality and then evaluated for injuries and scale loss. Two control and two treatment fish were examined prior to each trial for handling injuries. Two more fish were examined thoroughly after the trial before being held for 96 hrs to assess latent mortality. Other environmental conditions (temperature, dissolved oxygen, total gas saturation, turbidity, and debris load) were monitored also.

Twenty-four trials (each lasting 24 hrs) were conducted to sample naturally occurring fish entrained when the two lifts and the single pump were run simultaneously. Entrained fish were enumerated by species and the number of immediate mortalities was recorded. Live entrained fish were examined for injuries.

Results of the 27 trials during which both Archimedes lifts were operated reveal that there were no pump passage effects on survival since the mean survival of all treatment and control groups was 98.3 to 99.0% (Table 9-3). Statistically significant ( $P$ -value  $\leq 0.05$ ) relationships were determined using the Wilcoxon signed rank test. Results of the 40 trials during which one lift and one Hidrostal pump were operated reveal that there was a statistically significant pump passage effect associated with the Archimedes lift (despite high survival rates) (Table 9-4). Similarly, a significant pump passage effect is shown to exist for the treatment fish passing through the Hidrostal pump when compared to controls. Finally, the higher survival of lift-passed fish over that of pump-passed fish is shown to be significant. No significant difference was found to exist for the 96-hr latent survival between treatment and control fish from either trial group. Therefore, the authors concluded that the significant pump passage effects seen are attributable to immediate mortalities. Control groups for both the lift and pump trials had significantly higher immediate survival than the treatment groups of these same trials. Of the fish that were immediate mortalities, 25% of the controls and 89% of the treatment fish had “strike” or “grinding” injuries caused by contact with the impeller blades and fixed parts of the pumps.

**Table 9-3**

**Survival for juvenile Chinook salmon in test groups used to compare Archimedes-1 and Archimedes-2 lifts on the Sacramento River at Red Bluff, CA (McNabb et al. 2003).**

| Test groups                        | Number of Paired Releases | Survival (%) |          | Wilcoxon Statistic | P-Value |
|------------------------------------|---------------------------|--------------|----------|--------------------|---------|
|                                    |                           | Mean         | Range    |                    |         |
| Archimedes 1 control vs. treatment | 27                        | --           | --       | 0.535              | 0.593   |
| Archimedes 1 control               | --                        | 98.3         | 86.7–100 | --                 | --      |
| Archimedes 1 treatment             | --                        | 98.8         | 92.6–100 | --                 | --      |
| Archimedes 2 control vs. treatment | 27                        | --           | --       | 0.158              | 0.875   |
| Archimedes 2 control               | --                        | 99           | 93.5–100 | --                 | --      |
| Archimedes 2 treatment             | --                        | 98.8         | 90.6–100 | --                 | --      |
| Archimedes 1 vs. 2 controls        | 27                        | --           | --       | 0.891              | 0.373   |
| Archimedes 1 vs. 2 treatments      | 27                        | --           | --       | 0.059              | 0.953   |

**Table 9-4**

**Survival of juvenile Chinook salmon in test groups used to compare the Archimedes lifts and Hidrostal pump (McNabb et al. 2003).**

| Test groups                         | Number of Paired Releases | Survival (%) |          | Wilcoxon Statistic | P-Value |
|-------------------------------------|---------------------------|--------------|----------|--------------------|---------|
|                                     |                           | Mean         | Range    |                    |         |
| Archimedes control vs. treatment    | 40                        | --           | --       | 2.257              | 0.024   |
| Archimedes control                  | --                        | 99.5         | 93.8-100 | --                 | --      |
| Archimedes treatment                | --                        | 98.6         | 85.7-100 | --                 | --      |
| Hidrostal control vs. treatment     | 40                        | --           | --       | 3.276              | 0.001   |
| Hidrostal control                   | --                        | 98.9         | 92.9-100 | --                 | --      |
| Hidrostal treatment                 | --                        | 96.5         | 85.2-100 | --                 | --      |
| Archimedes vs Hidrostal controls    | 40                        | --           | --       | 1.612              | 0.107   |
| Archimedes vs. Hidrostal treatments | 40                        | --           | --       | 2.333              | 0.020   |

Fish size did not significantly affect passage survival in lift trials, while size did have a significant effect on the survival of fish passing through the pump. Though some passage related injuries were documented, no significant difference was noted between injuries of treatment and

control fish in both the lift and pump trials. For example, the percent of descaling on the body of both treatment and control fish was similar: 8–23% descaled on affected control fish, and 8–35% descaled on affected treatment fish. Survival was not significantly related to debris load either.

During the 24 trials run to entrain naturally occurring species at Red Bluff, 6,110 fish representing 27 species were collected. Of these, 55% were juvenile Chinook salmon. Ninety-eight percent of all the fish collected were  $\leq 200\text{mm}$  ( $< 7.9$  in). Though survival was slightly higher for those fish entrained by the lifts, there was no significant difference between the survival of Chinook entrained by the lifts or the pump (Table 9-5). The injury rates for Chinook associated with passage through each intake were 2.2, 1.5, and 3.0% for lift 1, lift 2, and the pump respectively. A significant relationship between Chinook survival and debris load during these trials was found, though during the trials there was considerably more debris build up in the holding tanks since they were only checked once every 24 hrs as opposed to being checked every 2 to 3 hrs during the experimental release trials with the hatchery reared fish.

**Table 9-5**  
**Mean percent survival (S) and total numbers of fish collected from holding tanks (C) for juvenile Chinook salmon and the four other most common fish species that were entrained from the Sacramento River during 24-hr trials (N = 24) (McNabb et al. 2003).**

| Species                | Archimedes 1 |       | Archimedes 2 |       | Hidrostal |       |
|------------------------|--------------|-------|--------------|-------|-----------|-------|
|                        | S            | C     | S            | C     | S         | C     |
| Chinook salmon         | 98           | 918   | 98           | 1,806 | 94        | 613   |
| prickly sculpin        | 98           | 683   | 98           | 420   | 95        | 501   |
| lamprey ammocoetes     | 99           | 175   | 99           | 126   | 98        | 251   |
| Sacramento sucker      | 97           | 29    | 89           | 27    | 89        | 19    |
| Sacramento pikeminnow  | 100          | 28    | 98           | 40    | 86        | 14    |
| all but Chinook salmon | 95           | 1,098 | 95           | 769   | 94        | 906   |
| all fish               | 96           | 2,016 | 97           | 2,575 | 94        | 1,519 |

Overall, the survival of fish passed through the Archimedes lifts was slightly higher than those passed through the Hidrostal pump. Both pumps however show promise in successfully passing juvenile Chinook salmon without significant injury.

In other studies at Red Bluff, researchers quantified the amount of stress experienced in passage through Archimedes lifts and a Hidrostal pump. Through the measurement of plasma cortisol levels (elevated levels indicate stress) in post-passage juvenile Chinook salmon, stress could be monitored over an extended period of time (Weber et al. 2002).

The evaluations took place at the Red Bluff Research Pumping Plant, which contained two Archimedes lifts and one Hidrostal pump. The Archimedes lifts had intake pipes measuring 1.2 m (3.9 ft) in diameter with rotating cylinders measuring 11.6 m (38.1 ft) in length and 3.05 m (10 ft) in diameter. The cylinders contained three internal flights. The Hidrostal pump had an intake diameter of 0.91 m (3 ft), and a single vane impeller. The lift was operated at 26.5 rpm, yielding

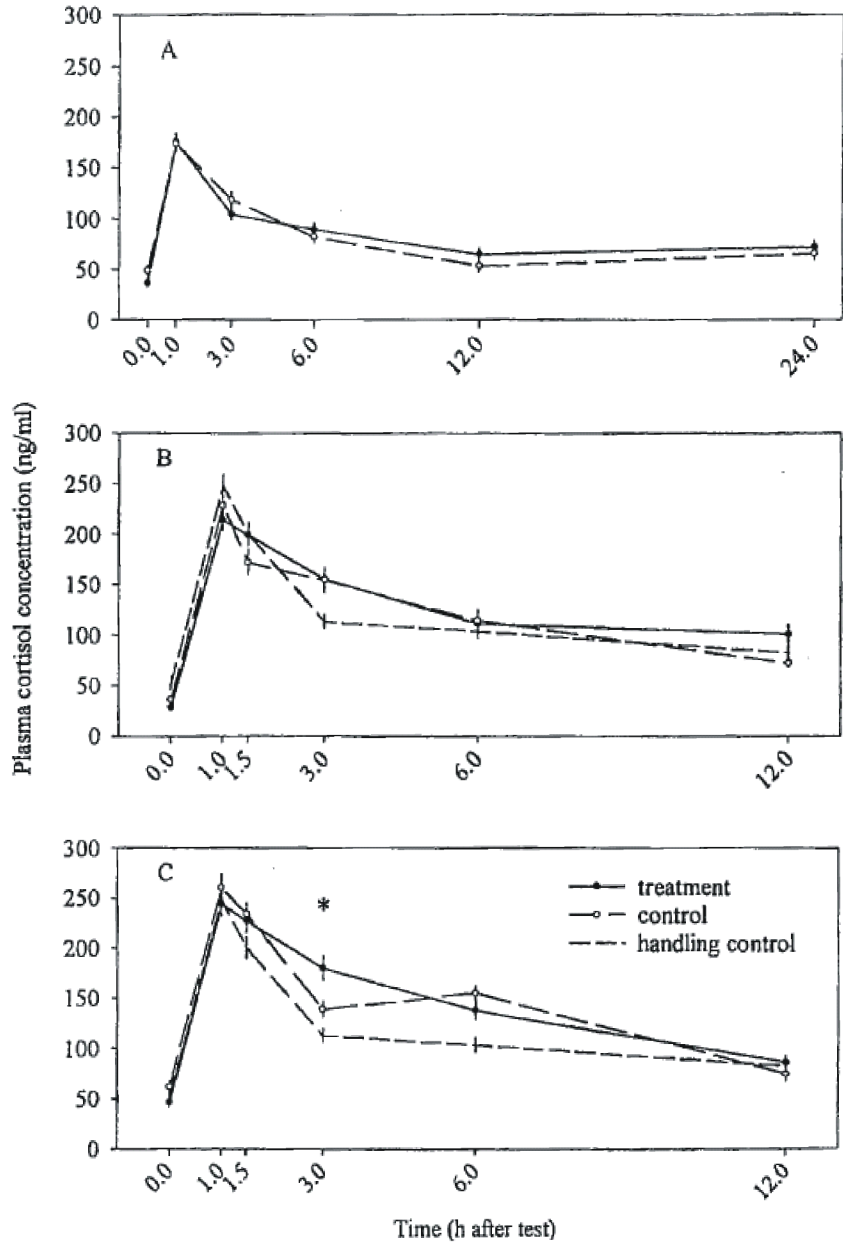
a discharge of 2.4 m<sup>3</sup>/sec (84.8 cfs), and the pump was operated at 350 rpm, yielding a discharge of 2.3 m<sup>3</sup>/sec (81.2 cfs). Water discharged by the lifts and pump traveled through a concrete sluiceway where approximately 90% of the water was removed via vertical wedge wire screening. The remaining 10% containing the debris and fish was diverted to a dewatering ramp where fish and debris were intercepted and diverted to holding tanks.

All trials were conducted 2 hrs before sunrise during mid to late summer in 1998 and 1999. During this time, water temperature averaged 14.0°C; turbidity averaged 5 NTU; and dissolved oxygen averaged 97% saturation. Throughout the 2 years of study, a total of 6 trials were conducted on each of the two Archimedes lifts (1998 and 1999), 6 trials on the one Hidrostral pump (1999), and 6 handling control trials (1999).

Juvenile Chinook salmon (75 to 87 mm [3 to 3.4 in]) for this evaluation were obtained from the Coleman National Fish Hatchery. The fish were held up to 4 weeks prior to testing in flow through tanks supplied with well water. Fish were fin clipped to distinguish between treatment and control fish and also between test groups. Forty-eight hrs prior to testing, fish were acclimated to river water. For a trial, 400 fish (200 control and 200 treatment) were removed from the holding tanks and placed in carboys for transport. The treatment fish were then lowered through the 30 cm (11.8 in) wide insertion tube and released into the lift or pump intake, while the control fish were released in the sluiceway just downstream of the pump or lift discharge. The handling controls went through the pre-trial netting, carboy transport, and were lowered and raised through the insertion tube before being released to a post-trial holding tank.

Twelve fish from each group (treatment or control) were removed immediately upon collection and euthanized (in a solution of Fiquel and sodium bicarbonate) to take plasma cortisol samples. The remaining fish were transferred in carboys to holding tanks where 12 fish were euthanized at each observation interval (1, 3, 6, 12, and 24 hrs) to take plasma cortisol samples in 1998. In 1999, 12 fish were euthanized at 1, 1.5, 3, 6, and 12 hrs for plasma cortisol samples. Plasma cortisol samples were analyzed by an independent laboratory.

Though there was a peak (~175 ng/mL) in plasma cortisol levels at 1 hr post-test for both treatment and control fish, there were no significant differences between the two groups passed through the Archimedes lift in 1998 (Figure 9-5). The slight increase in plasma cortisol levels between 12 and 24 hrs for this group of fish suggests that stress may have been caused by confinement in the holding tanks.



**Figure 9-5**  
**Mean plasma cortisol concentrations (ng/mL; vertical bars represent 1 SE) of Chinook salmon (A) at 0, 1, 3, 6, 12, and 24 hrs after passage through Archimedes lifts during 1998 (706 fish), (B) and 0, 1, 1.5, 3, 6, and 12 hrs after passage through Archimedes lifts (720 fish) or (C) a Hidrostral pump (710 fish) during 1999. Asterisk indicates a significant time-specific difference between treatment and control groups. The handling control was not compared statistically with the other groups (Weber et al. 2002).**

During the 1999 Archimedes trials, the same trend prevailed, revealing no significant difference between plasma cortisol levels of treatment and control fish. There was a similar peak (~225 ng/mL) at 1 hour post-test for both groups. The significant interaction between time and group revealed that treatment and control groups may respond differently over time.



During the 1999 Hidrostral trials, there were no significant differences between treatment and control fish. There was a peak (~250 ng/mL) in plasma cortisol levels 1 hour after passage for both groups. A significant difference between treatment and control fish is seen at 3 hrs, when treatment fish exhibited higher levels of plasma cortisol. Like the 1999 Archimedes trials, there was a significant interaction between time and group, indicating that treatment and control groups may respond differently over time.

Plasma cortisol levels in the handling control fish also peaked at 1 hour post-test, however their levels decreased faster than any other groups between hours 1 and 6, indicating (when compared to trial controls) an amount of stress being experienced in passage through the screening facilities as opposed to the pump passage itself.

Estimates of the overall passage effects are given in Table 9-6. The treatment effect represents the difference between plasma cortisol levels in treatment and control fish.

**Table 9-6**  
**Estimates of overall treatment effects for juvenile Chinook salmon passed through the Archimedes lifts and Hidrostral pump (Weber et al. 2002).**

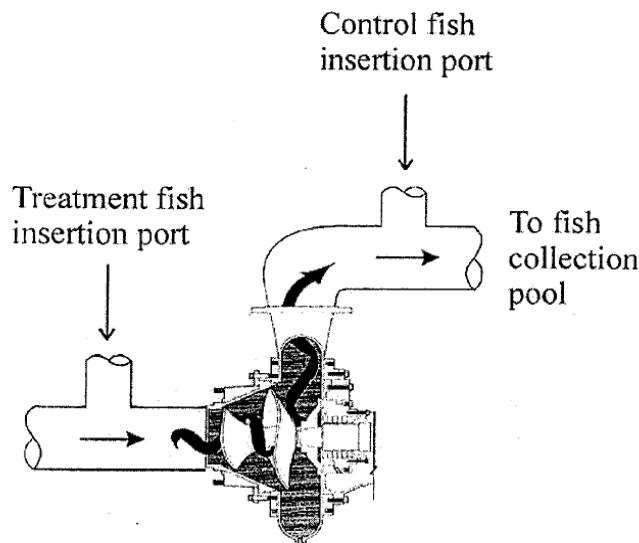
|                       | Treatment Effect (ng/mL) | 95% Confidence Interval (ng/mL) |
|-----------------------|--------------------------|---------------------------------|
| Archimedes lifts 1998 | < 1                      | 0–8                             |
| Archimedes lifts 1999 | 5                        | 0–17                            |
| Hidrostral pump 1999  | < 1                      | 0–13                            |

Since lethal limits of cortisol levels in juvenile Chinook salmon have been established at 400 to 500 ng/mL, it is believed that neither the lift nor the pump will have an adverse impact on their survival after passage. The authors suggest that further research is needed on the ecological consequences of increased cortisol levels and if it affects fish behavior by limiting escape from predators.

### **Tracy Fish Collection Facility**

A field evaluation of a Hidrostral fish pumping system was conducted at the Tracy Fish Collection Facility in the Central Valley of CA during 1998 and 1999 (Helfrich et al. 2001). This facility is part of the Tracy Pumping Plant, which supplies approximately  $2.5 \times 10^9 \text{ m}^3$  ( $8.8 \times 10^{10} \text{ ft}^3$ ) of water annually to the Delta-Mendota Canal for irrigation and industrial needs. Fish are guided via louvers to collection tanks where they are then lifted and trucked back to the rivers. The feasibility of installing a fish pump in lieu of the lifting buckets is addressed in this study. Specifically, this study aimed to elucidate the survival and injury rates of splittail and Chinook salmon passed through the pump; the immediate survival of native and nonnative species; and the relationship between mortality and injury as functions of species, size, density, pump speed, debris load, and various environmental conditions.

A Hidrostral pump with an intake measuring 41 cm (16.1 in.) in diameter was used in this study (Figure 9-6). The pump was run at speeds of 461 to 601 rpm, generating velocities of 0.17 to 0.40  $\text{m}^3/\text{sec}$ , for 25 to 35 min per trial. Trials were conducted during 2 to 3 day periods during each month of the evaluation in order to gather data on a variety of species.



**Figure 9-6**  
**Cross-sectional view of the Hidrostal pump and fish injection ports (the fish protective impeller shroud is not shown in this drawing) (Helfrich et al. 2001).**

Splittail were collected directly from the Sacramento-San Joaquin Delta, while juvenile Chinook salmon were obtained from the Mokelumne River Hatchery. Test fish were marked, injected in groups of 20 to 30 just upstream of the pump intake through a 30.5cm (12 in.) diameter pipe, passed through the fish return piping, and discharged into a collection pool measuring 4.2 by 8.5 by 1.2 m (13.8 by 27.9 by 3.9 ft). Collected fish were assessed for immediate mortality and then dipnetted from the tank and evaluated for injuries such as scale loss. After two representative fish (“quality controls”) were examined thoroughly, the collected fish were transferred to holding tanks and monitored daily for latent mortality (96 hrs). A minimum of 6 replicates of each treatment and control condition were completed for both splittail and Chinook salmon.

The average recovery rate for test fish (splittail and salmon) was 97% (Table 9-7 and Table 9-8). Ninety-nine percent of injected fish were recovered after 4 days. Fish not recovered were assumed to be alive and holding somewhere in the system. Immediate survival rates for both species averaged over 99%. Latent (96 hr) survival averaged 93% for splittails and 96% for Chinooks. The only significant difference noted between treatment and control fish was the decreased survival of splittail at 96 hrs for the June trials (Table 9-7). This has been attributed to high water temps that existed during splittail testing. Pump speed (461–604 rpm), debris load (10-7,000 g/L wet weight), and fish density (8 to 39 injected fish/L) did not significantly affect survival of splittails or Chinooks. Descaling rates for splittails and Chinooks averaged 1.9 and 2.4% of the body, respectively. When compared to handling and pumping controls, the Hidrostal pump was shown to have no significant effect on descaling rates. Temperature was directly correlated to scale loss.

Average injury rates to the head, eyes, skin, and fins ranged from 1.5 to 10.3% for splittails and from 0.1 to 0.6% for Chinook salmon (Table 9-9 and Table 9-10). The only significant difference noted between injury rates of treatment and control fish occurred during March trials with splittails; however, these increased rates have been attributed to nitrogen supersaturation caused by a broken air pipe in the holding system and not the fish pump.

**Table 9-7**

**Mean recovery and immediate and 96 hour survival of splittail passed through the Hidrostral pump (treatment fish) compared with those of control fish (Helfrich et al. 2001).**

| Group     | Month | Trials (N) | Fish In (N) | Fish Out (%) | Survival (%) |       |
|-----------|-------|------------|-------------|--------------|--------------|-------|
|           |       |            |             |              | Immediate    | 96hr  |
| Treatment | Dec   | 10         | 295         | 98.3         | 99.6         | 97.8  |
| Control   |       | 10         | 284         | 96.9         | 99.0         | 90.8  |
| Treatment | Feb   | 9          | 177         | 99.4         | 100.0        | 100.0 |
| Control   |       | 9          | 179         | 95.5         | 99.4         | 98.3  |
| Treatment | Mar   | 6          | 142         | 97.9         | 99.1         | 99.1  |
| Control   |       | 6          | 162         | 98.6         | 92.9         | 92.9  |
| Treatment | Apr   | 12         | 240         | 97.1         | 98.3         | 94.7  |
| Control   |       | 12         | 237         | 97.1         | 99.5         | 95.7  |
| Treatment | May   | 11         | 240         | 98.7         | 98.6         | 83.1  |
| Control   |       | 11         | 218         | 97.2         | 100.0        | 85.9  |
| Treatment | Jun   | 21         | 409         | 99.3         | 99.8         | 83.0  |
| Control   |       | 21         | 416         | 97.8         | 100.0        | 90.0  |
| Treatment | Jul   | 20         | 447         | 98.5         | 98.9         | 92.6  |
| Control   |       | 20         | 430         | 99.2         | 99.5         | 95.6  |

**Table 9-8**

**Mean recovery and immediate and 96 hour survival of Chinook salmon passed through the Hidrostral pump (treatment fish) compared with those of control fish (Helfrich et al. 2001).**

| Group     | Month | Trials (N) | Fish In (N) | Fish Out (%) | Survival (%) |      |
|-----------|-------|------------|-------------|--------------|--------------|------|
|           |       |            |             |              | Immediate    | 96hr |
| Treatment | Feb   | 7          | 160         | 95.6         | 98.1         | 96.9 |
| Control   |       | 7          | 138         | 99.3         | 99.3         | 99.3 |
| Treatment | Mar   | 13         | 332         | 95.7         | 98.6         | 98.6 |
| Control   |       | 13         | 311         | 94.7         | 99.6         | 98.8 |
| Treatment | Apr   | 11         | 263         | 99.6         | 98.6         | 92.4 |
| Control   |       | 11         | 263         | 98.5         | 99.6         | 78.3 |
| Treatment | May   | 10         | 220         | 98.3         | 99.5         | 95.8 |
| Control   |       | 10         | 201         | 99.0         | 100.0        | 96.4 |

**Table 9-9**  
**Descaling and injury for quality control (handling), control (no pump passage), and treatment (pump passage) groups of splittail (Helfrich et al. 2001).**

| Group           | Month | Fish (N) | Descaling (% of body) | Body injury (% of fish) |      |      |      |
|-----------------|-------|----------|-----------------------|-------------------------|------|------|------|
|                 |       |          |                       | Head                    | Eyes | Skin | Fins |
| Quality Control | Dec   | 40       | 1.4                   | 20                      | 55   | 2.5  | 52.5 |
| Control         |       | 20       | 1.6                   | 10                      | 95   | 5    | 55   |
| Treatment       |       | 20       | 1                     | 15                      | 80   | 5    | 15   |
| Quality Control | Feb   | 36       | 3.1                   | 0                       | 2.8  | 0    | 30.6 |
| Control         |       | 18       | 2.8                   | 0                       | 5.5  | 0    | 11.1 |
| Treatment       |       | 18       | 2.6                   | 0                       | 0    | 0    | 0    |
| Quality Control | Mar   | 32       | 1.4                   | 0                       | 6.3  | 0    | 9.4  |
| Control         |       | 18       | 1.9                   | 0                       | 5.6  | 5.6  | 5.6  |
| Treatment       |       | 18       | 1.3                   | 0                       | 0    | 11.1 | 22.2 |
| Quality Control | Apr   | 44       | 1.1                   | 0                       | 0    | 0    | 0    |
| Control         |       | 22       | 1.5                   | 0                       | 0    | 0    | 0    |
| Treatment       |       | 22       | 1.3                   | 0                       | 0    | 0    | 0    |
| Quality Control | May   | 40       | 1.6                   | 0                       | 0    | 0    | 0.2  |
| Control         |       | 20       | 1.8                   | 0                       | 0    | 0    | 0.4  |
| Treatment       |       | 20       | 2.2                   | 0                       | 0    | 0    | 0.4  |
| Quality Control | Jun   | 50       | 3.9                   | 0                       | 5    | 0    | 6.5  |
| Control         |       | 25       | 3.9                   | 2                       | 2    | 0    | 8    |
| Treatment       |       | 25       | 2.6                   | 2                       | 2    | 0    | 6    |
| Quality Control | Jul   | 40       | 2.4                   | 0                       | 0.3  | 0    | 0.1  |
| Control         |       | 20       | 2.7                   | 0                       | 0.3  | 0    | 0.1  |
| Treatment       |       | 20       | 2.6                   | 0                       | 0.4  | 0    | 0.1  |

**Table 9-10**  
**Descaling and injury for quality control (handling), control (no pump passage), and treatment (pump passage) groups of Chinook salmon (Helfrich et al. 2001).**

| Group           | Month | Fish (N) | Descaling (% of Body) | Body injury (% of fish) |      |      |      |
|-----------------|-------|----------|-----------------------|-------------------------|------|------|------|
|                 |       |          |                       | Head                    | Eyes | Skin | Fins |
| Quality Control | Feb   | 28       | 0.1                   | 14.3                    | 0    | 3.6  | 3.6  |
| Control         |       | 14       | 0.1                   | 7.1                     | 14.3 | 7.1  | 0    |
| Treatment       |       | 14       | 0.6                   | 0                       | 0    | 0    | 14.3 |
| Quality Control | Mar   | 38       | 0.3                   | 0                       | 0    | 0    | 18.4 |
| Control         |       | 20       | 1.5                   | 0                       | 0    | 5    | 20   |
| Treatment       |       | 18       | 4.3                   | 0                       | 0    | 0    | 0    |
| Quality Control | Apr   | 44       | 0.7                   | 0                       | 0    | 0    | 0    |
| Control         |       | 22       | 0.3                   | 0                       | 0    | 0    | 0    |
| Treatment       |       | 22       | 0.8                   | 0                       | 0    | 0    | 0    |
| Quality Control | May   | 40       | 3.8                   | 0                       | 0    | 0    | 0    |
| Control         |       | 20       | 3.8                   | 0                       | 0    | 0    | 0    |
| Treatment       |       | 20       | 4                     | 0                       | 0    | 0    | 0    |

Incidental collection of 7,197 fish representing 26 other species entrained during this evaluation allowed generation of additional survival data. The average survival of these species was 99% (Table 9-11).

While other evaluations concluded that pump speed (tested in wider ranges of 385–950 rpm with smaller pumps) was significantly correlated to survival and injury rates, the author found no correlation between the speeds tested during this evaluation (400–600 rpm with a larger pump) and survival and injury.

**Table 9-11**

**Monthly number, total length range, and survival rate of native and nonnative fish entrained and passed through the helical pump at the Tracy fish collection facility (Helfrich et al. 2001).**

| Species                                             | Dec | Jan | Mar | Apr | May | Jun   | Jul | Total Length (mm) | Survival (%) |
|-----------------------------------------------------|-----|-----|-----|-----|-----|-------|-----|-------------------|--------------|
| white catfish <i>Ameiurus catus</i>                 | 25  | 5   | 37  | 22  | 3   | 26    | 100 | 70–208            | 99           |
| threadfin shad <i>Dorosoma petenese</i>             | 3   | 21  | 22  | 3   | 0   | 9     | 40  | 49–98             | 98           |
| American shad <i>Alosa sapidissima</i>              | 3   | 8   | 0   | 1   | 0   | 1     | 75  | 74–119            | 100          |
| splittail <i>Pogonichthys macrolepidotus</i>        | 2   | 7   | 0   | 0   | 1   | 7     | 21  | 21–206            | 97           |
| yellowfin goby <i>Acanthogobius flavimanus</i>      | 2   | 0   | 0   | 0   | 0   | 0     | 1   | 85–179            | 100          |
| tule perch <i>Hysterothorax traski</i>              | 3   | 3   | 2   | 3   | 2   | 0     | 2   | 99–138            | 100          |
| channel catfish <i>Ictalurus punctatus</i>          | 3   | 2   | 2   | 2   | 0   | 25    | 22  | 71–129            | 100          |
| brown bullhead <i>Ameiurus nebulosus</i>            | 1   | 1   | 0   | 1   | 4   | 0     | 0   | 121–316           | 100          |
| redeer sunfish <i>Lepomis microlophus</i>           | 1   | 2   | 0   | 0   | 1   | 1     | 3   | 154–280           | 100          |
| bluegill <i>Lepomis macrochirus</i>                 | 1   | 0   | 2   | 5   | 3   | 6     | 7   | 78–143            | 100          |
| Chinook salmon <i>Oncorhynchus tshawytscha</i>      | 0   | 44  | 13  | 137 | 195 | 38    | 0   | 50–106            | 100          |
| delta smelt <i>Hypomesus transpacificus</i>         | 0   | 15  | 0   | 0   | 379 | 164   | 0   | 33–72             | 99           |
| striped bass <i>Morone saxatilis</i>                | 0   | 9   | 6   | 2   | 353 | 4,913 | 298 | 17–118            | 99           |
| golden shiner <i>Notemigonus crysoleucas</i>        | 0   | 3   | 6   | 0   | 0   | 2     | 0   | 107–170           | 100          |
| red shiner <i>Cyprinella lutrensis</i>              | 0   | 2   | 0   | 0   | 0   | 0     | 0   | 59–60             | 100          |
| steelhead <i>Oncorhynchus mykiss</i>                | 0   | 1   | 7   | 7   | 1   | 0     | 0   | 222–288           | 100          |
| Sacramento blackfish <i>Orthodon microlepidotus</i> | 0   | 1   | 0   | 0   | 0   | 0     | 0   | 139               | 100          |
| bigscale logperch <i>Percina macrolepida</i>        | 0   | 1   | 1   | 1   | 0   | 0     | 0   | 117–133           | 100          |
| Common carp <i>Cyprinus carpio</i>                  | 0   | 0   | 1   | 1   | 0   | 1     | 2   | 163–228           | 100          |
| black crappie <i>Pomoxis nigromaculatus</i>         | 0   | 0   | 1   | 0   | 0   | 0     | 0   | 238               | 100          |
| inland silverside <i>Menidia beryllina</i>          | 0   | 0   | 7   | 0   | 0   | 0     | 1   | 60–74             | 100          |
| largemouth bass <i>Micropterus salmoides</i>        | 0   | 0   | 0   | 2   | 0   | 2     | 1   | 58–371            | 100          |
| longfin smelt <i>Spirinchus thaleichthys</i>        | 0   | 0   | 0   | 2   | 0   | 0     | 0   | 38                | 100          |
| prickly sculpin <i>Cottus asper</i>                 | 0   | 0   | 0   | 0   | 5   | 9     | 6   | 38–51             | 100          |
| hitch <i>Lavinia exilicauda</i>                     | 0   | 0   | 0   | 0   | 0   | 0     | 1   | 260               | 100          |
| American eel <i>Anguilla rostrata</i>               | 0   | 0   | 0   | 0   | 0   | 0     | 1   | 780               | 100          |

### **Agricultural Pump Station, Cherry Creek, Washington**

Cherry Creek is the lowest tributary to the Snoqualmie River in Washington (Thompson et al. 2011). The lower section of Cheery Creek has been ditched, straightened, and isolated from the floodplain. Two hydrostal pumps were installed at the Cheery Creek pump facility, Duvall, WA. These pumps replaced conventional axial pumps, which were causing harm to the listed juvenile Chinook salmon. The pumps move water from the a lateral ditch system, which provides water for agriculture, into the mainstem Cheery Creek and typically operate in April and June when water levels in the lateral ditch trigger operation.

One pump was low-pitch, low-volume screen impeller design (Wemco model MD – referred to hereafter as MD) the other was a high-pitch impeller designed for lower head and higher flow (Wemco model SS – referred to hereafter as SS). During the study, the pumps were operated manually with a variable frequency drive. Pumps were operated at maximum speed (Vmax) and optimal efficiency speed based on manufacturer’s efficiency curves (Vopt) (Table 9-12).

**Table 9-12**  
**Trial conditions tested. Reported capacities are site-specific electrical supply limits.**

| <b>Impeller</b> | <b>Pitch</b> | <b>Capacity (%)</b> | <b>Trial</b> | <b>Hz</b> | <b>Max Speed (rpm)</b> | <b>Flow Rate (cm<sup>3</sup>/sec)</b> | <b>Total Dynamic Head (m)</b> |
|-----------------|--------------|---------------------|--------------|-----------|------------------------|---------------------------------------|-------------------------------|
| MD              | Low          | 100                 | Vmax         | 60        | 870                    | 3,000 – 3,800                         | 2.04                          |
|                 |              | 50                  | Vopt         | 38        | 600                    | 1,500 – 1,900                         | 2.13                          |
| SS              | High         | 90                  | Vmax         | 45        | 653                    | 4,000 – 5,500                         | 2.13                          |
|                 |              | 50                  | Vopt         | 35        | 508                    | 2,000 – 2,750                         | 2.38                          |

Fish tests were conducted using two species of hatchery origin juvenile salmonids – steelhead (*Oncorhynchus mykiss*) and coho salmon (*Oncorhynchus kisutch*). Two size classes of coho were tested. Three replicate trials were conducted at each condition (approximately 50 individuals per replicate). Control fish were used to separate mortality associated with pump passage from mortality associated with handling, introduction, collection, and holding. Fish were introduced via pipe directly below the bellmouth into the pump. Immediately following passage, fish were collected and examined for injuries. Injuries were divided into categories: 0 – no injury; 1 – minor injury (bruising, descaling, and other abrasions); 2 – major injury (crushing and open wound lacerations); 3 – disorientation (loss of equilibrium, impaired swimming behavior); 4 – dead.

Instantaneous mortality rates ranged from 0 to 4% for the high-pitch trials and 3 to 10% for the low-pitch trials (Table 9-13). In all cases, instantaneous injury and death occurred in smaller percentages among the SS trials than the MD trials, indicating that the pump with the high-pitch impeller designed for lower head and higher flow was more fish-friendly than the pump with the low-pitch, low-volume screen impeller design.

**Table 9-13**

**Death and injury rates. Hydrostal pumps with two impeller/speed configurations:  $M_{max}$ , low-pitch impeller, maximum speed;  $M_{opt}$ , low-pitch impeller optimal speed;  $S_{max}$ , high-pitch impeller, maximum speed; and  $S_{opt}$ , high-pitch impeller, optimal speed.**

| Species       | Condition | n   | Injury Type (%) |      |     |      |     |
|---------------|-----------|-----|-----------------|------|-----|------|-----|
|               |           |     | 0               | 1    | 2   | 3    | 4   |
| coho fry      | $M_{max}$ | 148 | 77.0            | 12.8 | 1.4 | 1.4  | 7.4 |
|               | $M_{opt}$ | 146 | 82.2            | 8.2  | 0.7 | 3.4  | 5.5 |
|               | $S_{max}$ | 150 | 88.0            | 6.7  | 0.7 | 0.7  | 4.0 |
|               | $S_{opt}$ | 150 | 86.0            | 9.3  | 0.7 | 0.0  | 4.0 |
| coho yearling | $M_{max}$ | 92  | 59.8            | 23.9 | 1.1 | 5.4  | 9.8 |
|               | $M_{opt}$ | 114 | 78.9            | 9.6  | 0.9 | 1.8  | 8.8 |
|               | $S_{max}$ | 146 | 89.7            | 6.8  | 0.0 | 3.4  | 0.0 |
|               | $S_{opt}$ | 147 | 89.1            | 8.2  | 0.0 | 2.0  | 0.7 |
| steelhead     | $M_{max}$ | 78  | 38.5            | 35.9 | 7.7 | 10.3 | 7.7 |
|               | $M_{opt}$ | 75  | 69.3            | 26.7 | 0.0 | 1.3  | 2.7 |
|               | $S_{max}$ | 125 | 75.2            | 20.8 | 0.0 | 2.4  | 1.6 |
|               | $S_{opt}$ | 150 | 84.7            | 12.7 | 0.0 | 0.0  | 2.7 |

## Case Studies – Hydroelectric Application

### *R. H. Saunders Generating Station*

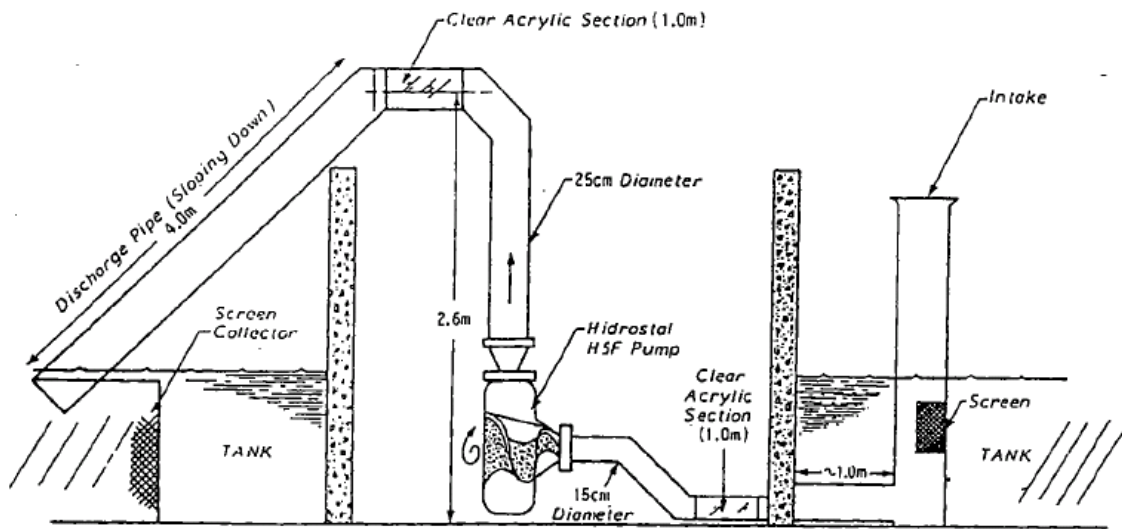
The effectiveness of using a Hidrostal pump for the live transfer of American eels over a hydroelectric dam was evaluated at the Saunders Generating Station on the St. Lawrence River near Cornwall, Ontario, in September 1985. A submersible Model 16-F Hidrostal pump was submerged approximately 2 m (6.6 ft) below water level and operated at a fixed impeller speed of 1,200 rpm. The calculated head of the transport system was over 10 m (33 ft), with a discharge rate of 0.18 m<sup>3</sup>/sec (6.2 cfs) and a velocity of approximately 5.1 m/sec (17 ft/sec). At the beginning of a test, fish were placed in a wire enclosure leading directly to the pump intake. Fish densities varied from 34 to 547 individuals per liter over a series of 18 tests. Survival was determined immediately following pump passage (time 0 h) and at 24, 48, 72, 96, and 148 hrs. In total, 2,300 American eels were passed live through the pump with no latent mortality. Fish injury was minimal, averaging less than 3% over all test conditions (Patrick and McKinley 1987).



## Case Studies – Laboratory Evaluations

### Laboratory Study – Ontario Hydro

This laboratory study evaluated the effectiveness of a Hidrostral fish pump in transferring live eels, as well as the survival of eels passed through such a system. This study used a Hidrostral pump (model H5F) designed to pass solids up to 10 cm (3.9 in.) in diameter. The trials were conducted in a concrete pool measuring 6.0 by 6.0 by 1.2 m (19.7 by 19.7 by 3.9 ft). The pump intake pipe measured 15 cm (5.9 in) in diameter, while the discharge measured 25 cm (9.8 in) (Figure 9-7). At speeds over 1,000 rpm, velocities reached 4.4 and 1.6 m/sec (14.4 and 5.2 ft/sec) in the intake and discharge, respectively. Head loss through the test system was calculated to be 3.2 m (10.5 ft). Since eels actively avoided the pump intake, they were confined to the area immediately upstream of the intake with a screened cage during mortality testing. For this study, American eels (350 to 500 mm [13.8 to 19.7 in]) were collected from the R.H. Saunders Dam on the St. Lawrence River in Cornwall, Ontario.



**Figure 9-7**  
**Cross-sectional view through the laboratory testing facility (Patrick and Sim 1985)**

Variables during this evaluation were pump speed (890, 1,043, and 1,204 rpm) and fish density (13-85 fish/100 L water). Thirty-five trials were run at various treatment combinations. The testing schedule appears in Table 9-14. Survival rates and injuries were recorded at 0 hrs (immediate survival), 24, 48, and 72 hrs. Passage survival rates were adjusted for handling controls, which averaged less than 2% mortality (Patrick and Sim 1985).

**Table 9-14**  
**Effectiveness of a Hidrostral pump in the live transfer of American eels (*Anguilla rostrata*) (Patrick and Sim 1985)**

| Pump Speed (rpm) | No. of Tests | No. of Organisms/ Test | Approximate Density (No./100 L) | Percent survival following passage |       |       |       | Percent Injury | Type of Injury |
|------------------|--------------|------------------------|---------------------------------|------------------------------------|-------|-------|-------|----------------|----------------|
|                  |              |                        |                                 | 0 hr                               | 24 hr | 48 hr | 72 hr |                |                |
| 890              | 5            | 15                     | 13                              | 100.0                              | 100.0 | 93.3  | 98.7  | 5.0            | bruises        |
|                  | 5            | 30                     | 26                              | 100.0                              | 100.0 | 100.0 | 97.3  | 5.0            | bruises        |
| 1,043            | 5            | 15                     | 13                              | 100.0                              | 100.0 | 100.0 | 100.0 | 5.0            | bruises        |
|                  | 5            | 30                     | 26                              | 100.0                              | 100.0 | 100.0 | 100.0 | 5.0            | bruises        |
| 1,204            | 5            | 15                     | 13                              | 100.0                              | 100.0 | 100.0 | 100.0 | 5.0            | bruises        |
|                  | 5            | 30                     | 26                              | 100.0                              | 100.0 | 100.0 | 98.0  | 5.0            | bruises        |
| 1,043            | 4            | 50                     | 43                              | 100.0                              | 100.0 | 95.0  | 94.5  | 5.0            | bruises        |
|                  | 1            | 100                    | 85                              | 100.0                              | 100.0 | 100.0 | 100.0 | 5.0            | bruises        |

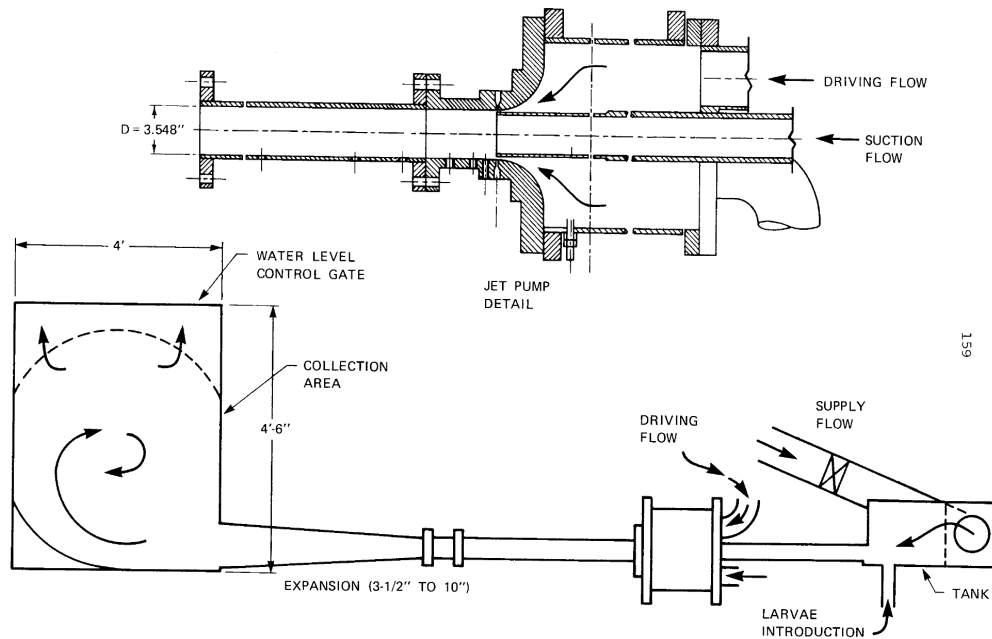
Observations during testing revealed that when crowded with a net, eels avoiding the intake's zone of influence could not maintain position at intake velocities greater than 1.0 m/sec (3.3 ft/sec). Overall, 72-hour survival for the 975 eels passed through the system at different treatment conditions averaged 98%. No significant differences were found between treatment and control fish. As shown in Table 9-14, no mortality was apparent until 48 hrs post-test. It was also noted that no latent mortality was evident for eels held several weeks post-test. Neither pump speed nor fish density had a significant effect on survival. Furthermore, there was no significant relationship between mortality and injury (bruising).

Though survival in this laboratory evaluation was high, the authors noted that the average head at the Saunders Generating Station is much larger, and that the effects of this increased head on passage survival are unknown.

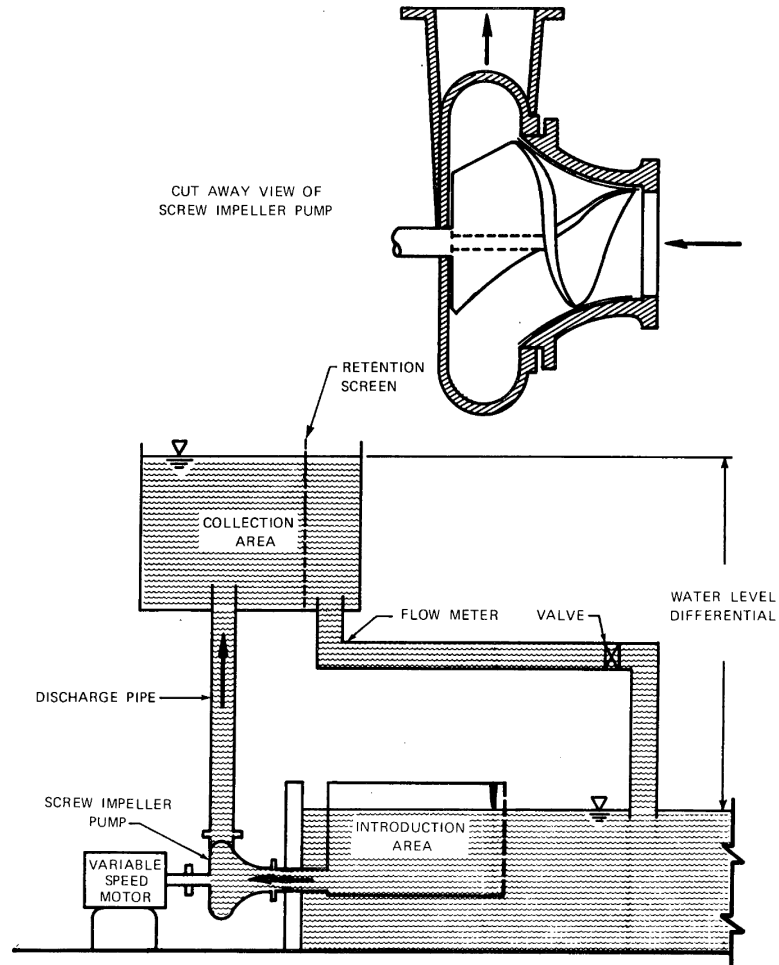
Earlier, Ontario Hydro evaluated the effectiveness of a 12.7 cm (5 in.) screw impeller pump and transport system in the laboratory using rainbow trout, alewife, yellow perch, and rainbow smelt (Patrick 1982a). Fish ranging in length from 7.9 to 20.1 cm (3.1 to 7.9 in.) were successfully transported through the pump with minimal damage. Survival varied with pump speeds and generally increased with a decrease in pumping speed. Few minor injuries were reported at pump speeds of 438 and 604 rpm. The highest survival after 48 hrs was obtained with rainbow trout (99.2%), followed by yellow perch (93.6%), alewife (91.2%), and smelt (90.1%). Juvenile gizzard shad, brown bullhead, and white sucker ranging from 8.9 to 40 cm (3.5 to 15.7 in.) in length were also passed through the pump at speeds of 604 and 944 rev/sec with essentially no mortality after 48 hrs (Patrick 1982a).

## Laboratory Study – ESEERCO

The Empire State Electric Energy Research Corporation (ESEERCO) sponsored a laboratory study designed to evaluate the effects of two pump types on the extended survival of fish larvae. A jet pump and a screw impeller-type Hidrostal pump were evaluated in this study. During initial testing, menhaden, alewife, white perch, and striped bass were used in the jet pump trials, while Hidrostal trials were conducted with juvenile alewife (ESEERCO 1981b). Figure 9-8 and Figure 9-9 show the design of the jet pump and Hidrostal test facilities, respectively.



**Figure 9-8**  
**Jet pump test facility (ESEERCO 1981b)**



**Figure 9-9**  
**Hidrostal pump test facility (ESEERCO 1981b)**

Jet pump trials were conducted in 1978 and 1979 with groups of 50 individuals at a jet nozzle velocity of 10.4 m/sec (34 ft/sec). The resulting suction pipe velocity and mixing tube velocity were 2.6 and 3.7 m/sec (8.5 and 12.3 ft/sec), respectively. Post-test fish were held for 96 hrs. A total of 32 trials were conducted; however, only 30 trials were used in the statistical analysis, since the two trials run with alewife were beyond the scope of this study. A summary of the results from the jet pump trials is presented in Table 9-15.

The results of the statistical analyses indicated that mortality was significantly influenced by temperature differences between the holding and testing water. Mortality was also significantly dependent upon species. Although, there were significant differences in mortality rates among species, the analyses indicate that passage through the jet pump did not significantly affect mortality rates within species (i.e. between test and control organisms).

Hidrostal trials were also conducted in 1978 and 1979 (ESEERCO 1981b). The preliminary trials in 1978 were conducted with juvenile menhaden, striped bass, and white perch. These trials resulted in both instantaneous mortality and high latent mortality (Table 9-16). Trials in 1979 were conducted with a modified pump design which included a shroud to decrease fish injury. Groups of 50 juvenile alewife were passed through the pump operating at a speed of 430

rpm. Post-test fish were held for 96 hrs. A total of 40 trials were conducted. The results are presented in Table 9-17. No statistical analyses were conducted on these data since both the values and the variability were low. It was concluded that passage through this modified (shrouded) Hidrostral pump did not significantly affect survival of juvenile alewife.

**Table 9-15**  
**Jet pump test results (ESEERCO 1981b)**

| Species      | No. of Tests | Range in Test Mortality (%) | Mean Test Mortality (%) | No. of Control Tests | Mean Control Mortality (%) |
|--------------|--------------|-----------------------------|-------------------------|----------------------|----------------------------|
| menhaden     | 9            | 2 - 20                      | 9.1                     | 5                    | 6.4                        |
| white perch  | 13           | 2 - 60                      | 24.9                    | 4                    | 25.0                       |
| striped bass | 8            | 4 - 28                      | 15.8                    | 3                    | 9.3                        |

**Table 9-16**  
**Hidrostral test results from 1978 trials (ESEERCO 1981b)**

| Species      | Length Range (cm) | No. of Fish Tested | Initial Mortality Range (%) | Total <sup>1</sup> 96-hr Mortality Range (%) | 96-hr Control Mortality Range (%) |
|--------------|-------------------|--------------------|-----------------------------|----------------------------------------------|-----------------------------------|
| menhaden     | 5.7 - 6.2         | 333                | 6.0 - 18.0                  | 10.6 - 66.0                                  | 10.0 - 26.0                       |
| striped bass | 9.4               | 100                | 0 - 16.0                    | 22.0 - 42.0                                  | 10                                |
| white perch  | 6.8               | 100                | 0 - 4.0                     | 36.0 - 66.0                                  | 44                                |

<sup>1</sup> Includes initial mortality

**Table 9-17**  
**Hidrostral test results 1979 (ESEERCO 1981b)**

| Species | No. of Tests | Length Range (cm) | Range in Test Mortality (%) | Mean 96-hr Test Mortality (%) | No. of Control Tests | Mean 96-hr Control Mortality (%) |
|---------|--------------|-------------------|-----------------------------|-------------------------------|----------------------|----------------------------------|
| alewife | 40           | 9.95 - 10.17      | 0 - 10.0                    | 1.25                          | 40                   | 1.25                             |

ESEERCO sponsored additional studies of the Hidrostral pump and the jet pump in 1979 and 1980 to determine their ability to transport striped bass, winter flounder, alewife, and yellow perch with low resultant mortality (ESEERCO 1981b). During these additional evaluations, the Hidrostral pump was evaluated with alewife and yellow perch larvae only. Alewife prolarvae could not be successfully tested due to their small size. Postlarvae were tested at mean lengths of 9.6 mm (0.38 in) (three tests) and 12.4 mm (0.5 in) (three tests). Mean test and control mortality among the 9.6-mm (0.38-in) group was 22.4 and 23.1%, respectively. Mean test and control mortality among the 12.4-mm (0.5 in) groups was 46.2 and 32%, respectively.

Yellow perch prolarvae (mean length of 6.1 mm [0.24 in]) were successfully tested in the Hidrostral pump. In three tests, mean mortality was 8.3%. No control larvae died. Yellow perch postlarvae were tested in four length groups (Table 9-18).

**Table 9-18**  
**Hidrostral test results – yellow perch prolarvae (ESEERCO 1981b)**

| Mean Length (mm) | Number of Tests | Mean Test Mortality (%) | Control Mortality (%) |
|------------------|-----------------|-------------------------|-----------------------|
| 6.5              | 3               | 93.2                    | 72                    |
| 7.3              | 3               | 9.7                     | 20                    |
| 7.6              | 3               | 52.4                    | 57.7                  |
| 19.4             | 2               | 0                       | 0                     |

In the jet pump studies, two nozzle velocities of 9.7 and 15.6 m/sec (31.8 and 44.6 ft/sec) were evaluated; however, percent mortality did not differ significantly. A total of 126 tests were conducted with striped bass larvae ranging in length from 7.5 to 35.5 mm (0.29 to 1.4 in.). Mean mortality for all tests was 4.7% with a 95% confidence interval of 3.7 to 6.1%. Control larvae experienced a mean mortality of 2.6% with a 95% confidence interval of 1.4 to 4.4%.

Alewife prolarvae (mean length of 6.0 mm [0.24 in]) were difficult to test due to their small size and transparency. These factors necessitated more extensive handling during collection than with larger larvae. Test mortality in two tests was 40 and 76%, while control mortality was 16%. Alewife postlarvae were tested at mean lengths of 9.6 and 12.4 mm (0.38 and 0.50 in). Mean mortality between the two test groups was 80 and 69.5%, respectively. Associated control mortalities were 8.3 and 32%.

Yellow perch prolarvae were also difficult to recover; however, one test with these 6-mm (0.23-in) larvae was successfully completed. Test mortality was 32%; controls were not held. Postlarvae were tested at four different mean lengths. Results are presented in Table 9-19.

**Table 9-19**  
**Jet pump test results – yellow perch postlarvae (ESEERCO 1981b)**

| Mean Length (mm) | Number of Tests | Mean Test Mortality (%) | Control Mortality (%) |
|------------------|-----------------|-------------------------|-----------------------|
| 6.5              | 3               | 91.2                    | 65.2                  |
| 7.3              | 2               | 44.7                    | 17.4                  |
| 8.1              | 4               | 86.5                    | 79.2                  |
| 19.4             | 2               | 10.0                    | 0.0                   |

### **Laboratory Study – Nine-mile and Mystic Stations**

From 1974 to 1976, Stone & Webster Engineering Corporation (SWEC 1977) evaluated the ability of a jet pump and a screw impeller pump (Hidrostal) to transport fish safely with low resultant mortality at the Alden Research Laboratory. The most pertinent of the jet pump studies involved the evaluation of a system demonstration model, which combined an angled screen model (discussed in Angled Screens) connected to a large-scale, peripheral-type jet pump by a pipe loop (SWEC 1977).

Biological test procedures involved introducing approximately 500 alewives per test into the angled screen model and allowing them to react naturally in the system. Fish that were successfully guided along the screen and that entered the bypass then passed through the pipe loop and the peripheral jet pump before being collected in the secondary bypass. Test fish were held 1 week for mortality studies. Results of the study are briefly summarized below.

It was anticipated that mortality in the system demonstration model would be higher than mortality with the angled screen alone (discussed in Angled Screens). This higher mortality would have been due to cumulative stresses from passage through a pipe and jet pump at high velocities and to guidance along a second screen to the collection area. However, such results were not observed. In 11 tests, with screen approach and bypass velocities ranging from 0.3 to 0.6 m/sec (1.0 to 2.0 ft/sec), pipe velocities from 1.5 to 2.7 m/sec (5 to 9 ft/sec), and jet nozzle velocities from 9.1 to 15.2 m/sec (30 to 50 ft/sec), the mean test mortality in the system was 11.8%. Mean control mortality was 7.8%, thus resulting in a mean differential mortality of 4%.

In 1979, Stone & Webster (1979) evaluated the ability of a 30.5 cm (12 in.) screw impeller centrifugal (Hidrostal) pump to safely transport fish. Using juvenile alewives, 40 tests were conducted from September through November 1979. Length of the alewives tested ranged from 9.9 to 10.1 cm (3.9 to 4.0 in). Approximately 50 fish per test were placed in a specially designed introduction box and passed through the pump, which was operated at a speed of about 430 rpm. Mortality of fish passing through the pump was very low. In the majority of the tests (27 out of 40), 100% survival was obtained. Mean test and control mortality were both 1.25%.





# 10

## ANGLED SCREENS

### Introduction

Angled fish diversion screens leading to bypass and return pipelines have been extensively investigated and are commonly used for guiding salmonids in the Pacific Northwest. A wide variety of other species have been shown to guide effectively on screens given suitable hydraulic conditions. In order to be biologically effective, angled screens require uniform flow conditions, a fairly constant approach velocity, and a low through-screen velocity. Resource agency design and operational criteria should be reviewed when designing an angled screen facility. In addition to concerns over predation at a screen bypass outfall, stresses associated with diversion and piping (and pumping that may be required in some cases to return fish to a safe release location) varies by species and also needs to be considered in evaluating potential effectiveness of angled screens at a given site.

Maintaining screens in a clean condition is critical to biological performance. McMillen and Smith (1996) present a review of available cleaning systems for use with angled, vertical flat-panel fish screen panels leading to a bypass. Most screen facilities of this type incorporate a profile wire (or wedgewire) screen design comprised of individual bars. The bars can be oriented either perpendicular or parallel to the flow. Screens with vertical bar orientations require specially-designed screen cleaning systems to match the exact orientation of the screen panels. To date, the most effective screen cleaning systems for this orientation has been mechanical (brush) screen cleaners and water backwash systems. Some facilities have used woven wire mesh which has different cleaning needs.

The basic criteria used when selecting a cleaning system are debris type, flow hydraulics, screen structure location, screen type, fish protection, operations and maintenance, and economics (McMillen and Smith 1996). In the case of floating debris, mechanical screen cleaning systems are best. For heavier debris, such as algae and ice, water backwash cleaning systems are more effective. Flow hydraulics are important in providing a sweeping mechanism for debris once it has been cleared from the screen face. Wedgewire screens are best cleaned with brushes, while wire mesh is best cleaned with backwash. In some cases, fish may need to be protected from the cleaning device, especially when a mechanical brush is used. Operations and maintenance requirements vary by site, but typically, mechanical cleaning is less complex and therefore less expensive than water backwash cleaning.

Mechanical cleaning systems, the most common type, usually consist of a brush mounted on a support frame that is pulled along the screen face. The brush is usually mounted on a monorail using either a motorized trolley or a cable trolley system. There are two cleaning actions incorporated into a mechanical cleaning system. First, the brush physically pushes small debris through the screen. Second, the brush creates eddies in its wake that lift the debris from the screen and carry it downstream as the brush moves toward the bypass. With the second cleaning action, the eddy actually does the majority of the cleaning. If the designer decides to implement a mechanical cleaning system, there are specific design characteristics that must be considered.

The screen must withstand the loadings created by the brush. The drive for the system's travel along the monorail must be easily accessible. An effective but not destructive travel speed for the brush must be chosen. Lastly, the brush position should always be known and monitored by some sort of tracking device.

Water backwash systems can be considered at sites where high velocities exist, space is limited, and/or distinct debris such as ice or weeds are a concern. The backwash system works by lifting the debris off the screen such that it is carried to the bypass by downstream currents. The backwash is created with high-pressure water jets that are directed toward the screen. The series of jets can be fixed or moveable. Coverage of each jet depends on the distance at which the jet is located from the screen. If the designer decides to implement a water backwash cleaning system, there are slightly different design characteristics that must be considered. Proper placement of the nozzles is imperative for cleaning efficiency. The nozzles should be as close to the screen as possible for maximum pressure to be exerted on the debris. A typical cleaning system should be designed to clean each screen on a 5 to 10 min rotating schedule. Plant operators should be able to easily inspect the cleaning system either visually or remotely by measuring headloss. Lastly, the spray water must be of sufficient quality to not add debris to the screen.

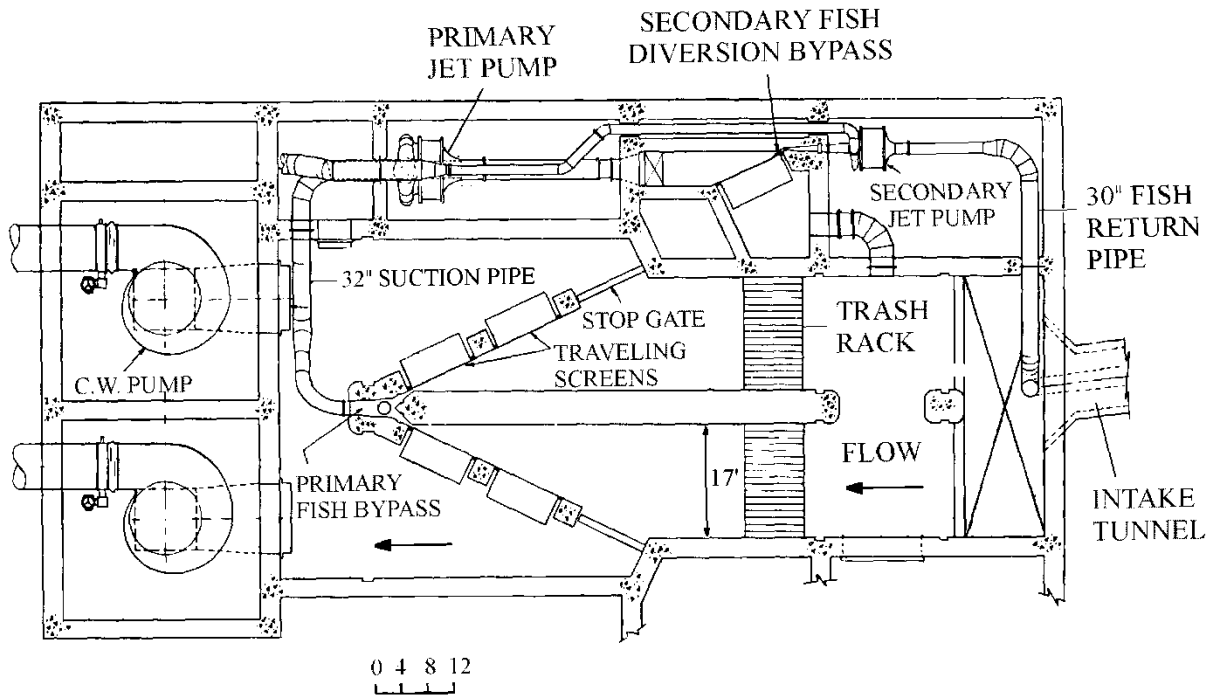
Angled flat-panel fish diversion screens are becoming common in the Pacific Northwest. In addition to the White River Project facilities (described in the angled bar rack and louver section), angled screens have been installed at a variety of other sites, but evaluations of their biological effectiveness have not been performed or are not available. Since most facilities have been designed to meet applicable and conservative resource agency criteria that target an effectiveness level of 100%, biological performance is likely high. Most screen installations have been installed to protect early life stages of salmonids. Therefore, information is sparse on the potential effectiveness of angled screen with the many non-anadromous species that commonly occur at many CWISs. However, if the stringent design and operating conditions applied to facilities in the Northwest are applied elsewhere, it is likely that angled screens will be reasonably effective. Therefore, data addressing the effectiveness of this technology with non-anadromous species is important. Such data is being generated in laboratory evaluations using potamodromous species in a "fish treadmill" at the University of California at Davis. By simulating a fish screen of indeterminate length, the design of the treadmill has allowed the testing of fish behavior, impingement, and survival in complex flow fields (approach and sweeping velocities) similar to those experienced at many CWISs (Swanson et al. 1998). Angled flat-panel screens, therefore, can be considered a viable option for protecting various species provided that proper hydraulic conditions can be maintained and that debris can be effectively removed.

## **Case Studies – CWIS Application**

### ***Oswego Steam Station***

Oswego Steam Station Unit 6 uses an angled screen diversion system similar to the system at Brayton Point Station Unit 4 (described below) (LMS 1992). Unit 6 has a maximum output rating of 815 MW. Two dry pit circulating water pumps draw water through a velocity cap inlet into two screen bays. Design flow is 20.5 m<sup>3</sup>/sec (724 cfs). Fish entering the screen well pass through a set of trash racks with 7.6 cm (3 in.) clear spacing before encountering four flush-mounted traveling screens angled toward a 15 cm (6 in.) wide bypass. The screens are 3 m (10

ft) wide with 9.5 mm (0.375 in.) mesh and are angled at 25 degrees to the direction of the flow (Figure 10-1 and Figure 10-2). Biological studies were conducted to investigate the effectiveness of the screens as both diversion and collection systems.



**Figure 10-1**  
**Oswego Unit 6 angled screen layout (LMS 1992)**



**Figure 10-2**  
**Oswego angled screen intake system dewatered (courtesy of Alden Research Laboratory, Inc.)**

A diversion flow-sampling program was conducted from April 1981–March 1984. The studies were designed to obtain biological performance on the angled screen/fish return system, i.e., bypass diversion efficiency and post-diversion survival. The angled screen bypass return system was evaluated by sampling the bypass flow from the primary and secondary screen wells offshore discharge pipe. The flow was diverted into a 2.4 by 2.4 m (7.9 by 7.9 ft) collection basin where organisms were collected, identified by species and condition, and held for initial and extended survival observations.

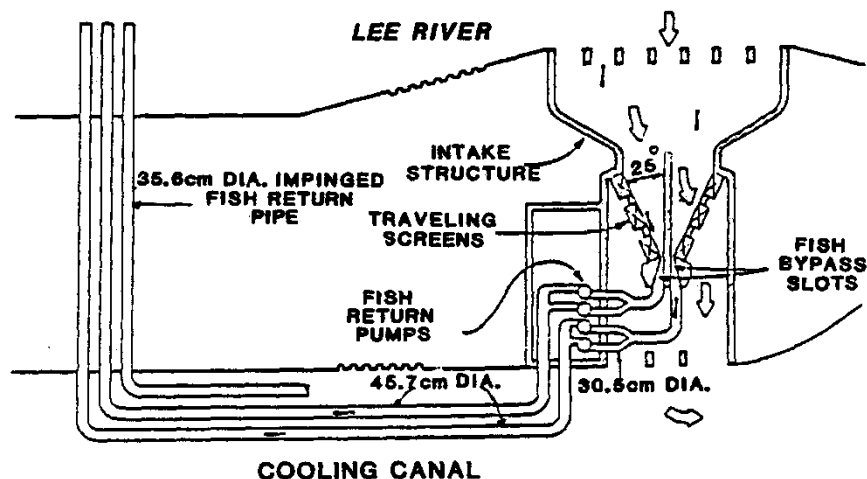
Alewife (*Alosa pseudoharengus*) and rainbow smelt (*Osmerus mordax*) made up 90% of the collected species (from April 1981–March 1983). Diversion efficiency was 79.3% and 74.2% for alewife and rainbow smelt, respectively. The combined diversion efficiency for all the species collected was 77.9%, ranging from 53.4% for mottled sculpin (*Cottus bairdii*) to 94.9% for gizzard shad (*Dorosoma cepedianum*).

Initial survival ranged from a low of 45.2% for rainbow smelt to a high of 87.4% for emerald shiner (*Notropis atherinoides*). A total of 34,294 individuals from the seven most frequently collected species were examined for initial survival and 7,534 fish were observed for extended survival. The lowest extended survival rate was exhibited by alewife (22.4%), while the highest was mottled sculpin (93.6%). Overall, the angled screen system was effective in diverting fish from the primary screen well through the secondary screen well back into the lake. The degree of effectiveness varied widely by species, size class (age), and condition of the population.

## Brayton Point

An 18-month (October 1984 to March 1986) biological evaluation was conducted at Brayton Point Station Unit 4 to determine the species, number, and initial and extended survival of fish diverted from the angled screen intake (Davis et al. 1988). We present a discussion of the collection system efficiency in Section 3 of this report.

The intake structure has eight openings 4.2 by 3.3 m (14 by 11 ft) that extend to the bottom of a skimmer wall. Trash racks with bar spacing of 7.5 cm (3 in.) on center cover the intake openings. Approximately 10 m (33 ft) behind the trash racks the width of the screen well constricts to 12.3 m (41 ft). A center wall divided the structure in half, and each half is equipped with three 3.0 m-wide (10 ft) flush-mounted modified vertical traveling screens. The screens are set at a 25 degree angle to the flow. Each screen panel is modified with a fish-lifting bucket and is capable of interchanging standard 9.5 mm (0.38 in.) screen and 1.0 mm (0.04 in.) fine-mesh screen. Cooling water is drawn into the intake structure, through the screens, and into a cooling canal by two circulating water pumps. The fish bypass is a rectangular opening 5.1 m by 15.2 cm (17 ft by 6 in.), located at the apex of each screenwell. The bypass leads into a 46 cm (18 in.) diameter bypass pipe. Two shrouded 30 cm (12 in.) diameter screw impeller centrifugal pumps discharge to the Lee River. Fish that do not enter the bypass and become impinged on the traveling screens are removed by a low-pressure backwash system and returned via a fish sluice back to the Lee River in the same location as the bypass return (Figure 10-3).



**Figure 10-3**  
Brayton Point Station Unit 4 angled screen intake structure fish return systems (Davis et al. 1988)

Diversion efficiency of the angled screen system was determined by comparing the proportion of fish entering the bypass to the number of fish entering the screen well. The number of fish entering the screen well was calculated by adding the number of fish impinged on the angled screens to the estimated number of fish diverted during the corresponding impingement period.

The angled screen intake system had a high diversion capability and demonstrated effectiveness for mitigating fish impingement. Initial and extended survival varied by species. However, a certain group of numerically dominant taxa was classified by the authors as “fragile” (primarily, bay anchovy [*Anchoa mitchilli*] and Atlantic silverside [*Menidia menidia*]). The fragile group had a calculated survival below 25.0% and a “hardy” group, dominated by winter flounder (*Pseudopleuronectes americanus*) and Northern pipefish (*Syngnathus fuscus*) had survival values greater than 65.0%.

A control study was also conducted to examine the effects of collection and handling on diversion and impingement survival. The control specimens were collected from the Lee River using various devices. The fish were marked by fin-clipping. Fish that were still alive after 24 hrs were introduced into their respective collection devices and held for the 48-hr survival evaluations.

The diversion efficiency for all species combined was 76.3%. The authors showed that the diversion efficiency was increased to 89.7%, when young-of-the-year bay anchovy, primarily collected with fine-mesh screens, were excluded. A total of 79,206 fish was collected from the angled screens and the diversion flow combined during the study period. An estimated 60,415 fish were netted from the diversion and 18,791 were collected from the angled screen wash water. Between August and September 1985, over 93% of the total bay anchovy entrapment occurred within a 2-month period. Fine-mesh screens were employed to exclude the entrainable-sized bay anchovy from the cooling canal. Nine of the top 12 taxa collected had diversion efficiencies greater than 83.2% (Table 10-1).

**Table 10-1**  
**Diversion efficiency of angled screens at Brayton Point (Davis et al. 1988)**

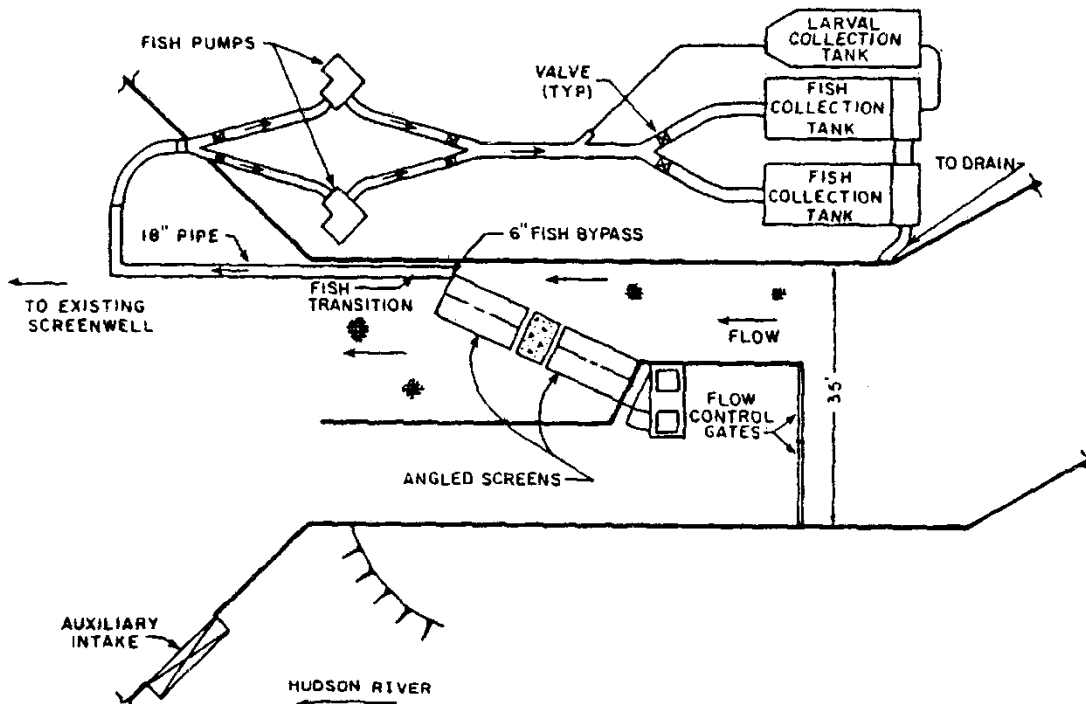
| Common Name                 | Number Collected |               | Collection by Location |                     | Diversion Efficiency (%) |
|-----------------------------|------------------|---------------|------------------------|---------------------|--------------------------|
|                             | Abundance        | % Composition | Impingement            | Estimated Diversion |                          |
| bay anchovy                 | 32,563           | 41.1          | 13,986                 | 18,577              | 57.0                     |
| Atlantic silverside         | 23,504           | 29.7          | 727                    | 22,777              | 96.9                     |
| winter flounder             | 8,284            | 10.4          | 1,021                  | 7,263               | 87.7                     |
| Northern pipefish           | 3,284            | 4.1           | 1,548                  | 1,736               | 52.9                     |
| threespine stickleback      | 1,481            | 1.9           | 113                    | 1,368               | 92.4                     |
| Atlantic menhaden           | 1,279            | 1.6           | 124                    | 1,155               | 90.3                     |
| fourspine stickleback       | 1,108            | 1.4           | 183                    | 925                 | 83.5                     |
| tautog                      | 843              | 1.1           | 319                    | 524                 | 62.2                     |
| American eel                | 837              | 1.1           | 5                      | 832                 | 99.4                     |
| butterfish                  | 819              | 1.0           | 37                     | 782                 | 95.5                     |
| hogchoker                   | 811              | 1.0           | 117                    | 694                 | 85.6                     |
| seaboard goby               | 750              | 0.9           | 126                    | 624                 | 83.2                     |
| others (45 taxa)            | 3,643            | 4.6           | 485                    | 3,158               | 86.7                     |
| total fish                  | 79,206           |               | 18,791                 | 60,415              | 76.3                     |
| total excluding bay anchovy | 46,643           |               | 4,805                  | 41,838              | 89.7                     |

The diversion flow collections resulted in an initial survival rate of 57.8% for all taxa (n=28,186) combined. The initial survival rate ranged from 5.6% for bay anchovy to 99.7% for American eel (*Anguilla rostrata*). Initial survival with the exclusion of bay anchovy was 82.6%. Extended survival for all fish (n=9,209) collected at the diversion flow was 63.4%. Extended survival trends were similar for the major species involved. Survival ranged from a low (bay anchovy) of 0% to a high of 99.6% (tautog [*Tautoga onitis*]).

### **Danskammer Point**

A full-scale angled screen test facility was constructed at the Danskammer Point Generating Station on the Hudson River in 1981 (LMS 1985). The angled screen facility was located in the cooling water intake canal (Figure 10-4) and consisted of two 3 m (10 ft) wide vertical traveling screens set at a 25 degree angle to the approach flow. The approach channel led to a 3 m (10 ft) high by 0.15 m (0.5 ft) wide bypass. The screens were designed with interchangeable screen panels with 9.6 and 1 mm (0.38 and 0.04 in.) mesh. The bypass led to a 0.46 m (1.5 ft) diameter pipe, which then bifurcated to two 0.3 m (1.0 ft) diameter pipes to convey bypassed organisms to

two 30.5 cm (12 in.) screw-impeller centrifugal pumps. The bypass approach velocity matched the angled screen approach velocity.



**Figure 10-4**  
**Danskammer angled screen system layout (LMS 1985)**

The effectiveness of the system was evaluated over a 3-year test period (LMS 1985). The study was separated into two programs: one to evaluate young-of-the-year and older fish and the second to evaluate ichthyoplankton.

Juvenile and older fish were collected on a seasonal basis from the fish pump discharge using nets (for determination of abundance) and from collection tanks from which fish could be evaluated for latent (96-hour) mortality. Nets located on the screenwash discharge were used to collect all fish impinging on the angled screens. A total of 59,309 fish representing 38 species were collected between February 18, 1981, and October 27, 1983. Study variables included velocity, conductivity, and diel periodicity.

Diversification efficiency ranged from 95.4 to 100.0%, with a mean of 99.4%. Species included bay anchovy, blueback herring (*Alosa aestivalis*), white perch (*Morone americana*), spottail shiner (*Notropis hudsonius*), alewife, Atlantic tomcod (*Microgadus tomcod*), pumpkinseed (*Lepomis gibbosus*), and American shad (*Alosa sapidissima*). Overall, system efficiency (diversion efficiency times; initial survival times; extended [96-hour] survival) ranged from 67.9% (alewife) to 98.7% (spottail shiner) with a mean of 84.4% (LMS 1985). Initial survival for all the organisms tested was variable among taxa and life stage. Juveniles generally exhibited higher survival compared to yolk-sac and post-yolk-sac larvae. Extended (48-hr) survival was highest for yolk-sac larvae and lowest for post-yolk-larvae. No significant difference was found for initial or extended survival between the three approach velocities tested. Results of the



young-of-the-year and older fish program indicate that the angled screen system is an effective device for mitigating impingement, has a high guiding capability, and demonstrates high initial survival of fish following passage through the system (LMS 1985).

## Case Studies – Hydroelectric Application

### *White River Hydroelectric Project*

Puget Sound Power and Light Company's (Puget Power) decided to replace the existing fish screens at its White River Hydroelectric Project in Washington (Dorratcague et al. 1996). Puget Power constructed the new fish screens as part of the FERC relicensing process. The screen structure is 105.0 by 21.3 by 8.5 m (344.5 by 69.9 by 27.9 ft) and is located in a power canal (Figure 10-5; Figure 10-6; and Figure 10-7).

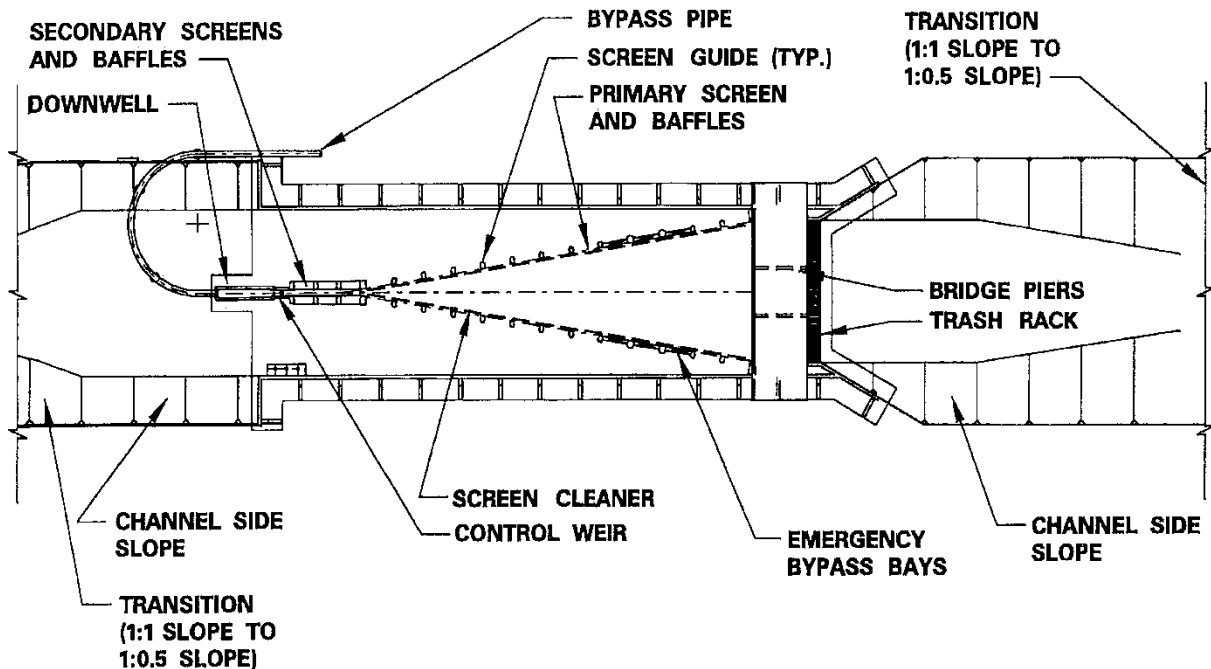
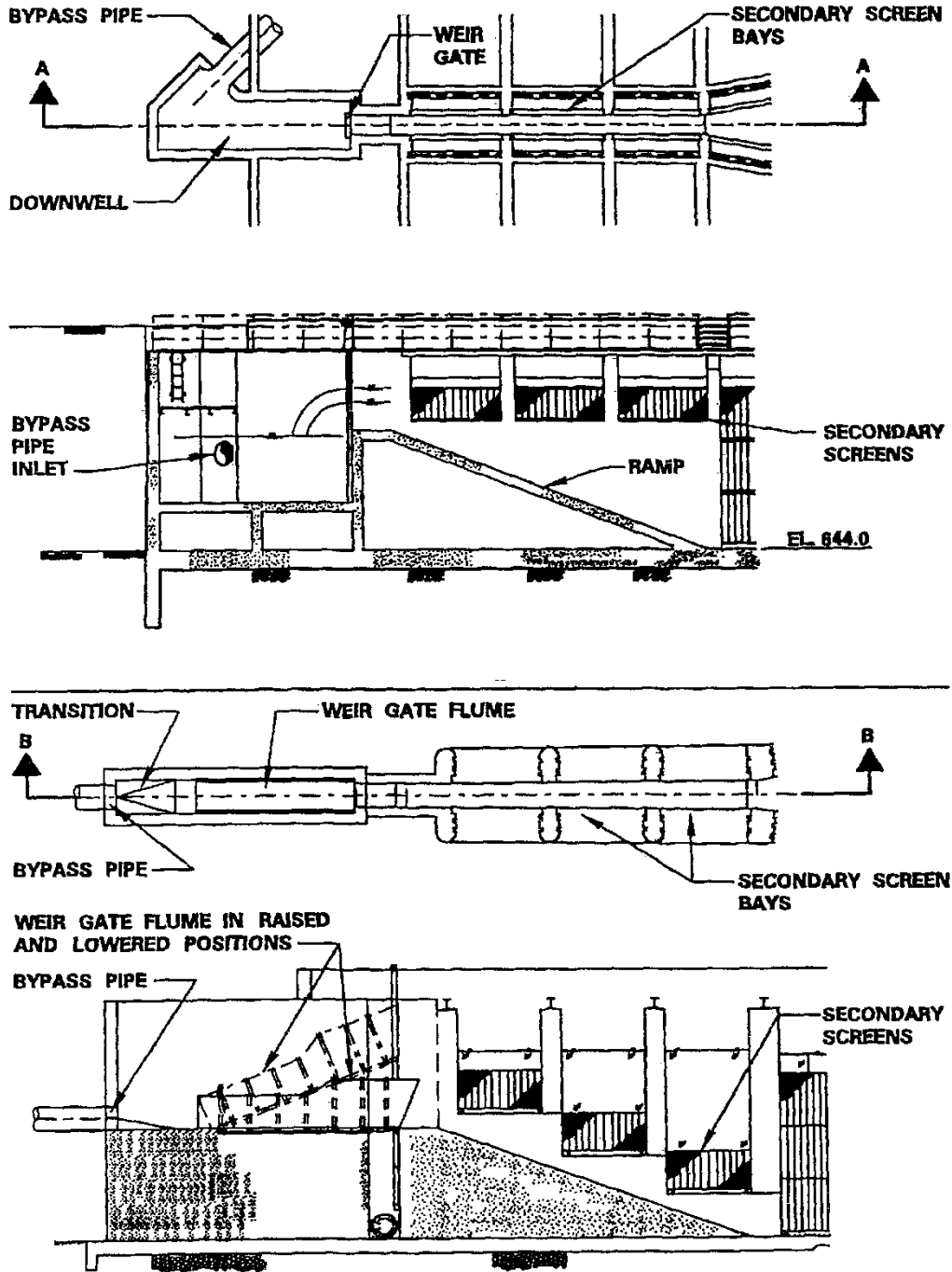


Figure 10-5  
White River angled screen system — plan view (Dorratcague et al. 1996)



**Figure 10-6**  
**White River screen system — section view (Dorrtcague et al. 1996)**

The primary screens are in a V-shape to guide the fish toward a bypass while allowing the majority of the flow to pass through the screens to the powerhouse. At the apex of the V, the screens are 1 m (3.3 ft) apart as they transition into a bypass. At this point, secondary screens are

installed in the bypass walls to further concentrate the bypassed fish. The secondary screens are vertical panels measuring 2.7 by 1.2 m (8.9 by 3.9 ft). The secondary screens guide fish to a return channel and pipeline for return to the White River downstream of the canal. The fish screening project became operational in 1996.



**Figure 10-7**  
**White River angled screen diversion system (courtesy of U.S. Filter — Johnson Screen)**

As part of the design effort for the new screens, Puget Power decided to conduct a physical model study of the proposed facility to optimize hydraulic conditions. The prototype design was modeled at a scale of 1:8.5. The model results identified several problems with the proposed design. The original design incorporated a downwell just prior to the fish entering the return channel. Because of a severe change in water direction in the downwell, water backed up enough in the bypass to create a vertical backroller along the screens. It was decided that the turbulence created by the backroller could potentially trap debris and injure fish. The screen structure was redesigned to incorporate an adjustable chute instead of the downwell. The model also identified the proper adjustment of flow-straightening baffles located downstream of the V-screens needed to create a uniform flow distribution over the screen surfaces. Finally, the model identified potential sediment deposition problems within the structure. To solve this problem, a high-pressure spray system was designed and the secondary screen panels were relocated to sufficiently increase velocities and minimize sediment deposition (Dorratcague et al. 1996).

In another paper on the White River Project, McMillan and Porter (1996) provide additional information on the planning and design of the V-screen facility. Using the results of the hydraulic model study, a final design was prepared. The screen structure size was determined based on the types and sizes of fish to be protected. The smallest and weakest-swimming fish (pink salmon [*Oncorhynchus gorbuscha*] fry) determined the screen mesh size and the maximum length of the screen allowable. The largest fish (spawned adult steelhead trout [*Oncorhynchus mykiss*]) determined the minimum bypass channel depth and the trash rack bar spacing. Physical

criteria determined in the planning and design stages included screen hydraulics, primary and secondary screens, and the bypass pipeline. The screen hydraulics consisted of a 56.6 m<sup>3</sup>/sec (2,000 cfs) maximum and a 0.57 m<sup>3</sup>/sec (20 cfs) minimum design flow, a 0.12 m/sec (0.4 ft/sec) velocity normal to the screen face, and a 0.61 m/sec (2.0 ft/sec) velocity in the channel approaching the screens. The selected screen material was a stainless steel vertical flat plate screen, with profile wedge-wire construction with a 2 mm (0.08 in.) clear bar spacing, a vertical bar orientation, an open area of 40%, a flow distribution system using baffles, brush and water backwash cleaning, and cleaner activation controls. The bypass pipeline was designed as a 76 cm (30 in.) diameter HDPE pipe 832 m (2,730 ft) in length with a design flow of 5.7 m<sup>3</sup>/sec (20 cfs).

### ***Weeks Falls Hydroelectric Project***

A series of monitoring studies were conducted at the Weeks Falls Hydroelectric Project to assess the hydraulic performance of its screening facility (Jarrett and Winchell 1989). Field velocities were measured as a requirement of the project's FERC license. The Project is located on the Snoqualmie River in Washington State. It is a run-of-river facility with a generating capacity of 5 MW and a maximum diversion of 21.2 m<sup>3</sup>/sec (750 cfs).

Water enters the intake through a trash rack and into two lateral intake channels. The water then passes through the screens into a central channel and enters into the power shaft. Fourteen traveling belt screens are arranged in two banks of screens. Each of the belt screens is 6.1 by 2.4 m (20 by 8 ft). The screens have an effective surface area of 11.7 m<sup>2</sup> (125.7 ft<sup>2</sup>) with the exception of the two downstream screens that have an effective screening surface of 9.6 and 5.2 m<sup>2</sup> (103.2 and 56.2 ft<sup>2</sup>), respectively.

Water velocities were measured on the front side of the screen. In addition, sweeping and facing velocities were recorded at nine positions on the face of each screen. Measurements were taken at 20, 50, and 80% of the total depth, and at each depth, measurements were made at 0.3, 1.2, and 2.1 m (1, 4, and 7 ft) from the upstream screen edge. Velocities were also measured at the back side of the screens 0.6 m (2 ft) below the water surface at distances of 0.4, 1.2, 1.8, and 2.1 m (1.3, 4, 6, and 7 ft) from the upstream edge of the screens.

Sweeping velocities ranged from 0.91 to 1.37 m/sec (3 to 4.5 ft/sec) at screens 1–7. Velocities measured at screens 8 through 14 were lower and more variable than the screens on the opposite side. Previous measurements of total flow volume indicated that flow volume is greater on the left bank of screens, which may have accounted for the difference in sweeping velocities. Facing velocities on screens 1–6 were 0.03 m/sec (0.1 ft/sec) and 0.15 m/sec (0.5 ft/sec) on screens 8–14. Screen 7 had a facing velocity of greater than 0.15 m/sec (0.5 ft/sec).

The initial measurements indicated a need to re-distribute flow to the upstream screens. Modifications were made to the facility, including an increase in flow through the fish bypass. Sweeping velocity measurements were similar to those made prior to the modifications. Facing velocities were more evenly distributed after the modifications. Behind-the-screen velocity measurements indicated high volume passing through the screens in the downstream end of the facility. It appeared that the modifications had moderated the flow passing through screens 7 and 14. The screen modifications were considered successful. Future investigations at Weeks Falls include the evaluation of baffles on screens 3 through 7 and 10 through 14.

## Case Studies – Laboratory and Field Studies

### Field Study Newhalen River, Alaska

A flume evaluation was conducted on the Newhalen River near Iliamna, Alaska, in June 1983 (Taft and Isakson 1983). This study focused on determining the potential effectiveness of a stationary angled screen for diverting sockeye salmon smolts and fry (*Oncorhynchus nerka*). Additionally, impingement survival studies were conducted.

A 2.4 by 1.2 by 1.2 m (8 by 4 by 4 ft) test flume was constructed to receive flow directly from the river for the testing of the angled screen. The screen was constructed of 2 mm (0.08 in.) spaced plastic mesh and was set at 25 degrees to the flow (Figure 1). The bypass located at the downstream end of the screen measured 6 in. wide, 24 in. long, and extended the full flume depth (18 in.). The upstream end of the flume was covered by 5 mm mesh to contain the test fish and block the passage of debris into the testing flume. Screening tests were conducted at an average approach velocity of 0.4 m/sec (1.3 ft/sec) for smolt and at a lower velocity (as low as 0.15 m/sec [0.5 ft/sec]) for fry.

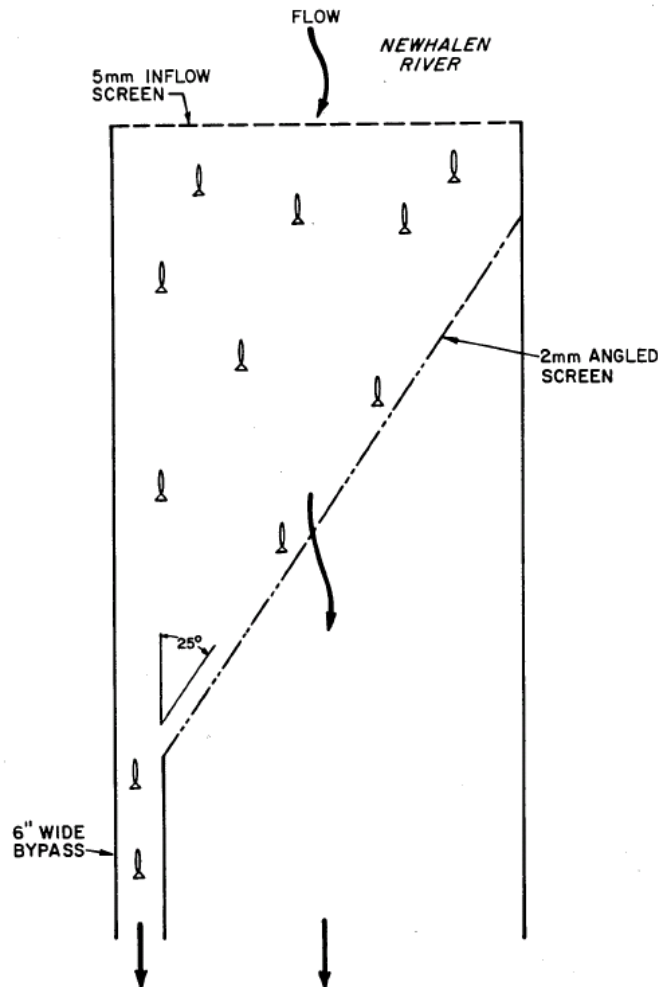


Figure 10-8  
Angled screen flume arrangement (plan) (Taft and Isakson 1983)

Impingement tests were conducted with fry in a segmented box inserted into the test flume. The box was divided into four channels, each measuring approximately 0.3 m (1 ft) wide. Screen test meshes included 1.0 and 2.0 mm (0.04 and 0.08 in.). Fish were introduced to the test channels and impinged on the screening mesh for durations of 8 and 16 min. Approach velocities in the testing channels ranged from 0.4 to 0.5 m/sec (1.2 to 1.5 ft/sec). Impinged fish were subsequently held for 48 hrs to assess latent mortality.

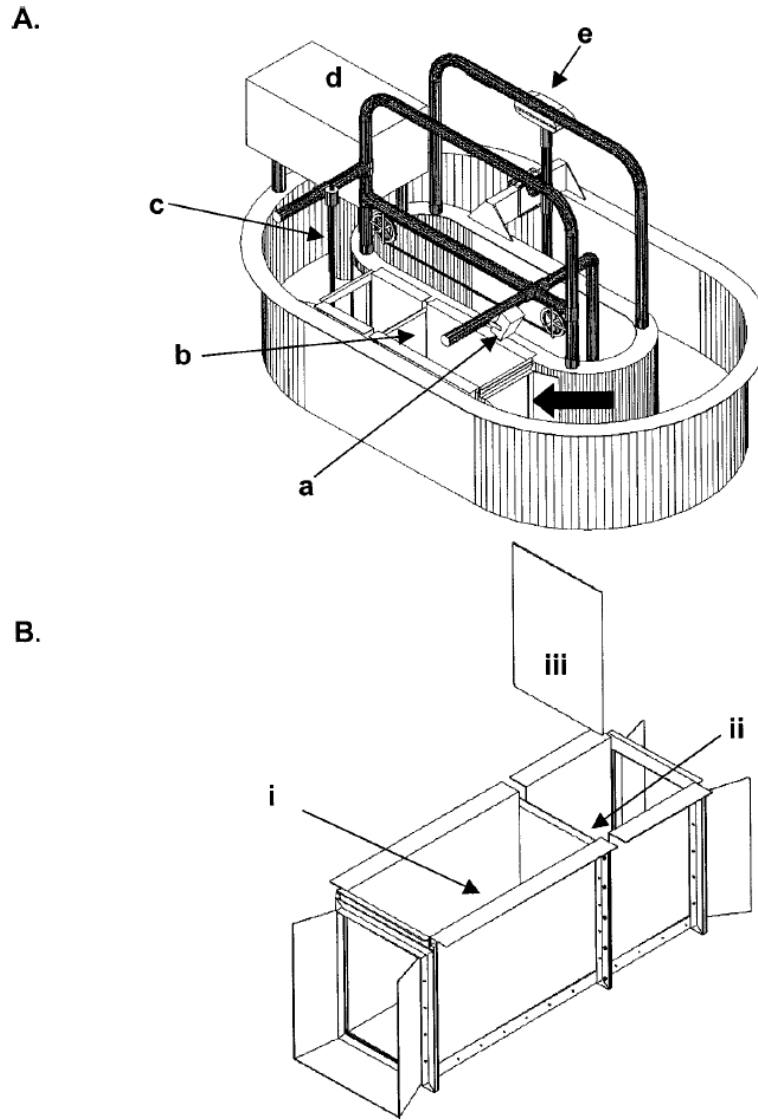
Results of the screening diversion tests reveal that smolt successfully maintained their position in the flume and easily avoided impingement at the velocities tested. Fry, however, displayed difficulty in diverting even at low velocities. Upon release, 50% of the fry typically impinged on the screen immediately but did eventually reach the bypass. The authors suggest that the high impingement rates of the fry indicate the need for a collection type screen for this life stage.

Results of the impingement tests indicate high fry survival within an 87.3% to 95.8% range. Average survival for all the test conditions was 93.1%. Control survival was 93.4%, indicating essentially no handling mortality. The authors indicate that there is potential for efficient diversion of sockeye salmon in the Newhalen River, but that further studies are required to quantify the effects of higher approach velocities (above 0.3 m/sec [1.1 ft/sec]) and the effects of abrasion on successfully diverted fish.

### **Laboratory Evaluation – U.S. Fish and Wildlife Creston National Fish Hatchery**

Bull trout (*Salvelinus confluentus*) are a threatened species that can be impinged and entrained at water diversion structures (Zydlewski and Johnson 2002). The authors evaluated whether existing fish screening criteria used in the Northwest are adequate to prevent the impingement and entrainment of recently emerged bull trout. Washington State screening criteria specify that approach velocity not exceed 0.12 m/sec (0.4 ft/sec) to protect salmonids fry less than 60 mm (2.4 in.) FL. These criteria define approach velocity as the water velocity component perpendicular to and approximately 7.6 cm (3.0 in.) upstream of the screen face. In addition, screening material must provide a minimum of 27% open area and can be made of perforated plate with openings not greater than 2.4 mm (0.09 in.), wedgewire with 1.75 mm (0.07 in.) bars, or woven wire with opening no greater than 2.4 mm (0.09 in.).

Tests were run from February 29 2000–March 4 2000 using bull trout 22.5–31.0 mm (0.9-1.2 in.) TL (Mean = 25.0 mm [1 in.]) that had been feeding for at least one week. Tests were conducted in an oval fish tank (Figure 1). Water depth was set at 35.6 cm (1.4 in.) and maintained between 6°C and 7°C throughout testing. Velocity was achieved using a propeller system and verified using a Swoffer meter calibrated for low flows. The test chamber was 102 cm (40.2 in.) long. Test fish were contained in the test chamber using 0.159 mm stretch mesh. Experimental test screens were located midway in the test chamber. Entrained fish were collected downstream of the experimental test screens. Test screens were metal plates with: 1) 2.4-mm (0.09 in.) evenly-spaced round openings (perforated plate, PP); 2) wedgewire (profile bar) with 1.75-mm (0.07 in.) openings oriented vertically (HPB); 3) 2.4 mm (0.09 in.) 14-gauge woven wire (WW) and 4) a no-screen control (CL). Twenty-five were introduced into the release area with the screen or no-screen (CL) in place.



**Figure 10-9**  
**Test tank (A) showing (a) video camera, (b) test chamber, (c) velocity meter), (d) cooling unit, and (e) propeller system. The thick black arrow shows the direction of flow. (B) Test chamber, showing (i) release area, (ii) capture area, and (iii) position of removable test screen (Zytlewski and Johnson 2002).**

Fish acclimated to the tank with no flow for the first 15 min then the propeller was turned on at the lowest setting to generate a flow of 0.03 m/sec (0.1 ft/sec). At 15-min intervals over 1 hour, velocity was increased to 0.12 m/sec (0.4 ft/sec) at 7.6 cm (3.0 in.) in front of screen to match the current design criteria. Water velocity was maintained at 0.12 m/sec (0.4 ft/sec) for the remainder of the 16 hour test (1545 to 0800 hrs). Once the velocity was set at 0.12 m/sec (0.4 ft/sec), fish were continuously observed of 1 hour and then checked every 30 min until 2200 and from 0400-0800 hrs ( $n = 23$  observations). The number of fish impinged and entrained was recorded. The individual time to impinge or entrain was subsequently observed from the videotapes. For these studies, impingement was defined as contact with the screen longer than 1 second. Any fish that did not contact the screen or entrain through the screen was considered

free swimming. During control replicates, entrainment was defined as those fish downstream of where the screen would have been and free-swimming as those upstream of where the screen would have been. The average number of fish impinged and entrained at the end of each 30-min observation was reported.

At the end of the experiment, three groups of live fish (free-swimming, impinged, and entrained) were transferred to separate holding tanks to assess 24-hour survival. Video tapes were used to determine the frequency of screen contacts. Prior to evaluating the video tapes, a single tape was analyzed to determine the frequency distribution of contacts. Since the majority (90%) of contacts occurred between 1700 and 0000 hrs, only this portion of the tapes was subsequently analyzed. Control tapes were not analyzed. Video analysis was used to determine the total number of contacts between 1700 and 0000 hrs, whether the fish escaped from the screen, and the start and end time of the contacts.

The greatest number of impingements was observed at the end of the VPB trials (approximately 3 fish; Table 10-2). The duration of contact with the VPB screen averaged 12.0 min. For the PP trials, an average of one fish was impinged on the screens at the end of each observation period. No fish were impinged in 13 of the 23 observation periods. Duration of impingement averaged 2.5 min. For HPB trials, an average of 1.61 fish were impinged. There were no impingements in 7 of the 23 observation periods. The duration of impingement on HPB screens averaged 7.1 min. For WW trials, an average of 1.26 fish were impinged. No fish were impinged in 5 of the 23 observation periods. The duration of contact averaged 6.8 min. During all testing, only one fish was entrained through a screen (VPB treatment). This fish was the smallest tested (23.0 mm [0.9 in.]). All the fish survived initially, but one control fish died during the 24 hrs after the experiment.

**Table 10-2**  
**Mean number (SEs in parenthesis) of bull trout entrained and impinged on various types of screen and the number surviving the experiments. Treatments were: CL = control; VPB = vertical profile bar (wedgewire); PP = perforated plate; HPB = horizontal profile wire (wedgewire); and WW = woven wire (Zydlewski and Johnson 2002).**

| Experimental Condition | Condition at the end of each 30-min interval |                 | Condition at the end of experiment |                 |                  | Number Surviving at 24-H |
|------------------------|----------------------------------------------|-----------------|------------------------------------|-----------------|------------------|--------------------------|
|                        | Number Entrained                             | Number Impinged | Number Entrained                   | Number Impinged | Number Surviving |                          |
| CL                     | 12.70 (1.30)                                 | 2.10 (0.30)     | 12                                 | 2 <sup>a</sup>  | 25               | 24                       |
| VPB                    | 0.05 (0.05)                                  | 2.75 (0.30)     | 1                                  | 3               | 25               | 25                       |
| PP                     | 0                                            | 0.39 (0.10)     | 0                                  | 1               | 25               | 25                       |
| HPB                    | 0                                            | 1.61 (0.31)     | 0                                  | 2               | 25               | 25                       |
| WW                     | 0                                            | 1.26 (0.20)     | 0                                  | 1               | 25               | 25                       |

<sup>a</sup> Two fish were impinged on the rear barrier screen.

The authors conclude that the screening criteria are likely protective of bull trout fry, but stressed that since these tests were restricted to organisms held at 6-7°C and averaged 25 mm (1 in.) TL, observations at field sites would be important to assure the protection of wild fish populations.



### **Laboratory Study, Redondo Beach, CA**

A laboratory evaluation was undertaken to assess the guidance and survival of larval fish along louvers and fine mesh angled screens at Southern California Edison's Redondo Beach laboratory (McGroddy et al. 1981). The flume in which the fish were tested contained a diversion system similar to the one installed at San Onofre Nuclear Generating Station (SONGS). The flume measured 1.8 m (6 ft) wide by 1.2 m (4 ft) deep and was capable of achieving flow velocities of 0.85 m<sup>3</sup>/sec (30 cfs). The louver array was set at 20 degrees to the flow and measured 3 m (10 ft) in length. The louver slats measured 6.4 mm (0.25 in) thick, 25 mm (1 in) deep, and were spaced 25 mm (1 in.) apart. For angled screen testing, panels of Smooth-Tex woven-wire mesh were flush mounted on the louver array. The mesh openings were 14.0 mm by 1.2 mm (0.6 in. by 0.05 in.) and oriented vertically when installed. The two approach velocities evaluated were 30 cm/sec (1.0 ft/sec) and 61 cm/sec (2.0 ft/sec), which corresponded to velocities of 12 cm/sec (0.4 ft/sec) and 24 cm/sec (0.8 ft/sec) at the louver array.

Successfully bypassed fish entered the 7.6 cm (3 in.) wide bypass opening where the velocity was maintained at 76 cm/sec (2.5 ft/sec) and were then collected in a fiberglass tray. Collected fish were assessed for immediate survival and then transferred to a holding facility where latent mortality was monitored at 24-hour intervals for a total of 96 hrs. Fish lengths were recorded at the completion of the 96-hour holding.

Three replicate trials were run for each combination of variables. Test fish were released 1.5 m (5 ft) in front of the upstream end of the louver array and 15.2 cm (6 in.) from the flume wall. Each trial was run for 10 min, after which the flume was drained and the test fish were collected. Total diversion efficiency represented the proportion of fish that were both diverted and survived. Results are presented in Table 10-3 by species for tests with the louvers and with the angled screen.

**Table 10-3**  
**Results of diversion tests for all species (McGroddy et al. 1981)**

| Mean Length (mm)  | Age (Days) | Approach Velocity (cm/sec) | No. of Replicates | Total No. of Fish | % Diversion | % Survival | % Total Efficiency |
|-------------------|------------|----------------------------|-------------------|-------------------|-------------|------------|--------------------|
| <b>Grunion</b>    |            |                            |                   |                   |             |            |                    |
| I. With Fine Mesh |            |                            |                   |                   |             |            |                    |
| 12.7              | 22         | 61                         | 3                 | 70                | 21          | 67         | 14                 |
| 15.7              | 36         | 61                         | 3                 | 90                | 3           | 33         | 1                  |
| 16.6              | 29         | 61                         | 3                 | 90                | 51          | 37         | 19                 |
| 18.9              | 54         | 61                         | 3                 | 90                | 66          | 34         | 22                 |
| 21.6              | 33         | 61                         | 3                 | 78                | 95          | 97         | 92                 |
| 23.8              | 51         | 61                         | 3                 | 45                | 87          | 74         | 64                 |
| 19.5              | 28         | 30                         | 3                 | 60                | 98          | 95         | 93                 |
| II. With Louvers  |            |                            |                   |                   |             |            |                    |
| 10.8              | 30         | 61                         | 3                 | 90                | 0           |            | 0                  |
| 15.5              | 38         | 61                         | 3                 | 90                | 3           | 33         | 1                  |
| 19.4              | 90         | 61                         | 3                 | 90                | 9           | 38         | 3                  |
| 27.3              | 101        | 61                         | 3                 | 90                | 27          | 58         | 16                 |
| 29.7              | 99         | 61                         | 3                 | 90                | 18          | 31         | 6                  |
| 32.2              | 106        | 30                         | 3                 | 89                | 47          | 12         | 6                  |
| 27.5              | 117        | 30                         | 3                 | 90                | 52          | 83         | 43                 |
| <b>Topsmelt</b>   |            |                            |                   |                   |             |            |                    |
| I. With Fine Mesh |            |                            |                   |                   |             |            |                    |
| 13.8              | wild       | 61                         | 3                 | 60                | 28          | 100        | 28                 |
| 18.2              | wild       | 61                         | 3                 | 59                | 49          | 100        | 49                 |
| 21.7              | wild       | 61                         | 3                 | 60                | 92          | 93         | 85                 |
| 22.3              | wild       | 61                         | 3                 | 60                | 93          | 98         | 91                 |
| 23.9              | wild       | 61                         | 3                 | 60                | 95          | 91         | 86                 |
| 26                | wild       | 61                         | 3                 | 60                | 98          | 100        | 98                 |
| II. With Louvers  |            |                            |                   |                   |             |            |                    |
| 28                | wild       | 61                         | 3                 | 60                | 48          | 100        | 48                 |
| 36.1              | wild       | 61                         | 3                 | 60                | 67          | 100        | 67                 |

| Mean Length (mm)              | Age (Days) | Approach Velocity (cm/sec) | No. of Replicates | Total No. of Fish | % Diversion | % Survival | % Total Efficiency |
|-------------------------------|------------|----------------------------|-------------------|-------------------|-------------|------------|--------------------|
| <b>White croaker</b>          |            |                            |                   |                   |             |            |                    |
| I. With Fine Mesh             |            |                            |                   |                   |             |            |                    |
| 24.1                          | 48         | 61                         | 3                 | 60                | 97          | 97         | 94                 |
| 34.2                          | 82         | 61                         | 3                 | 60                | 87          | 94         | 82                 |
| II. With Louvers              |            |                            |                   |                   |             |            |                    |
| 23.4                          | 53         | 61                         | 3                 | 60                | 8           | 100        | 8                  |
| 36.7                          | 83         | 61                         | 3                 | 60                | 5           | 100        | 5                  |
| 60                            | 134        | 61                         | 3                 | 60                | 87          | 40         | 35                 |
| <b>Kelpfish</b>               |            |                            |                   |                   |             |            |                    |
| I. With Fine Mesh             |            |                            |                   |                   |             |            |                    |
| 13                            | 32         | 61                         | 1                 | 22                | 5           | 0          | 0                  |
| 15                            | 29         | 61                         | 2                 | 54                | 48          | 0          | 0                  |
| 24.1                          | 51         | 61                         | 3                 | 30                | 80          | 54         | 43                 |
| II. With Louvers — No Testing |            |                            |                   |                   |             |            |                    |
| <b>Northern anchovy</b>       |            |                            |                   |                   |             |            |                    |
| I. With Fine Mesh             |            |                            |                   |                   |             |            |                    |
| 19.6                          | 46         | 61                         | 3                 | 55                | 20          | 18         | 4                  |
| 30.7                          | 50         | 61                         | 3                 | 45                | 91          | 20         | 18                 |
| 32.5                          | 48         | 61                         | 3                 | 60                | 77          | 28         | 21                 |
| II. With Louvers — No Testing |            |                            |                   |                   |             |            |                    |

A total of 42 tests were conducted with grunion larvae (*Leuresthes* spp.) that were reared in the laboratory from wild-caught eggs. Average lengths ranged from 10.8 to 37.5 mm (0.4 to 1.5 in.). Generally, results of testing with grunion and the fine mesh screen show an increase in diversion with increases in fish length at the 0.6 m/sec (2 ft/sec) velocity. With the approach velocity reduced to 0.3 m/sec (1 ft/sec), the efficiency increased to 93% from 22% for fish measuring 18.9 to 19.5 mm (0.7 to 0.8 in.). Trials in which the fine mesh screen was removed and the efficiency of the louver array alone was evaluated revealed a significant decrease in total efficiency to 16% and 43% for 0.6 and 0.3 m/sec (2.0 and 1.0 ft/sec) respectively.

A total of 24 tests were conducted with topsmelt (*Atherinops affinis*) larvae that were collected in the wild. Average lengths ranged from 13.8 to 36.1 mm (0.5 to 1.4 in.). All trials with topsmelt were conducted at the 2.0 ft/sec approach velocity. Similar to the fine mesh screen trials with grunion, an increase in diversion was noted with increased fish length. Mean survival for all tests was 97%. Trials in which the fine mesh screen was removed and the efficiency of the

louver array alone was evaluated revealed a significant decrease in diversion, but 100% survival as these fish were fully metamorphosed juveniles. No significant difference was found between trials run during daylight or darkness.

A total of 15 tests were conducted with white croaker larvae (*Genyonemus lineatus*) that were spawned in the laboratory. All trials with white croaker were conducted at the 0.6 m/sec (2.0 ft/sec) approach velocity. Fine mesh screen trials with the two sizes of fish tested yielded high diversion, survival, and total efficiencies. Louver trials of similar sized fish had significantly lower efficiencies and therefore significantly lower total efficiencies.

A total of 6 tests were conducted with giant kelpfish (*Heterostichus rostratus*) larvae that were reared in the laboratory from wild-caught eggs. All trials were run with the fine mesh screen at the 0.6 m/sec (2.0 ft/sec) approach velocity. Though a similar trend of increasing diversion with increasing fish length is seen, total efficiencies are extremely low due to the fragile nature of the species. The sensitivity of this species to handling stress is evidenced by the high (72%) control mortality.

A total of 9 tests were run with Northern anchovy larvae (*Engraulis mordax*) that were spawned in the laboratory. Average lengths ranged from 19.6 to 32.5 mm (0.8 to 1.2 in.). Although diversion rates were high for the larger fish, total efficiencies were low due to high mortality of test fish. Like the kelpfish, Northern anchovy experienced high control mortality (73 to 75%).

Overall results from this evaluation indicate that diversion efficiency and extended survival are species-specific and dependant on fish length and swimming ability.

Results of this evaluation were compared to previous larval diversion and survival testing done by ESEERCO (1981b, Table 10-4) and found to be similar. Diversion rates and total efficiencies from this evaluation with 1.2 mm (0.05 in.) slotted mesh most closely matched the diversion rates and total efficiencies for the 4.0 mm (0.2 in.) square mesh results from the ESEERCO study. Lower 50% and 100% diversion rates and total efficiencies were achieved in the ESEERCO study with the 1.0 mm (0.04 in.) mesh due most likely to the increased retention of smaller larvae by this size mesh. Overall, the authors conclude that diversion rates and total efficiencies increase with decreasing approach velocities and mesh size.

**Table 10-4**  
**Comparison of predicted lengths for diversion and total efficiency between the Redondo Beach study and the ESEERCO study (McGroddy et al. 1981)**

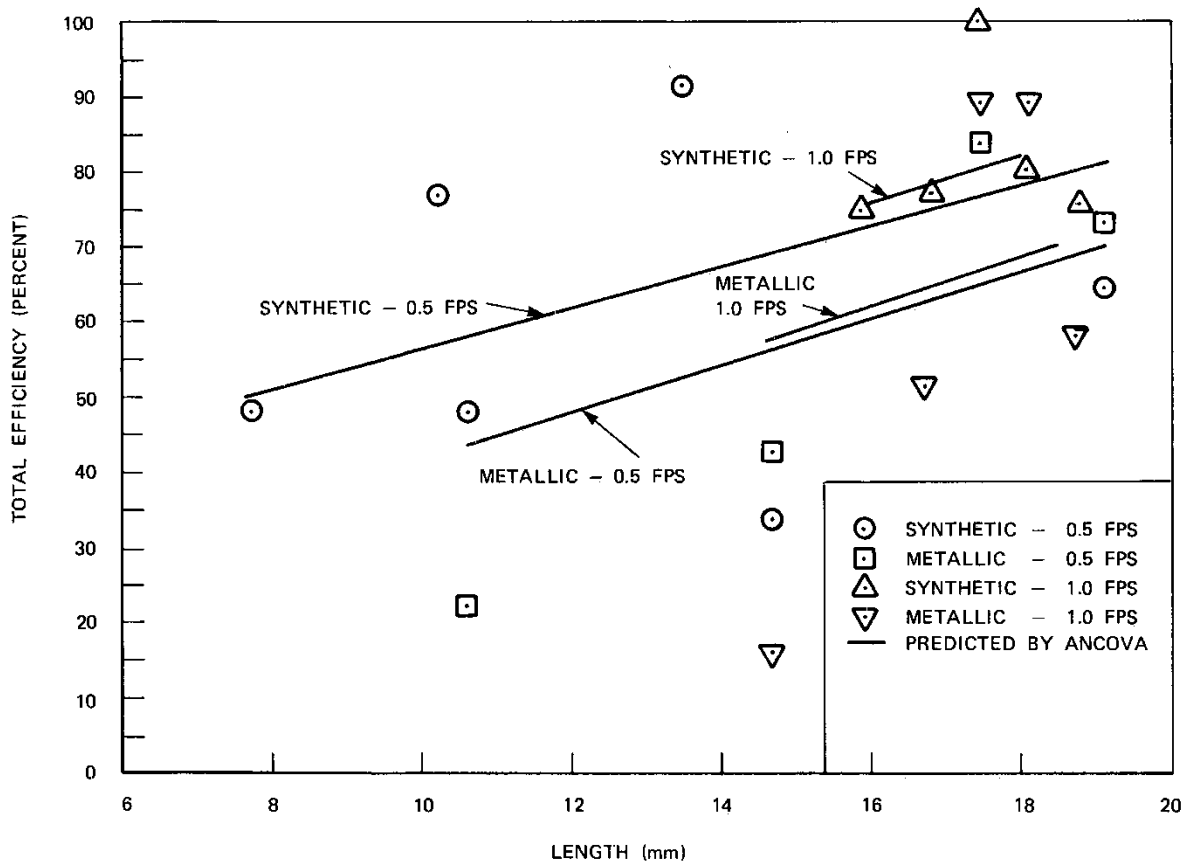
| I. ESEERCO Square Mesh         |       |         |         |            |         |         |         |
|--------------------------------|-------|---------|---------|------------|---------|---------|---------|
| Diversion                      |       |         |         | Efficiency |         |         |         |
| 1.0 mm                         |       | 4.0 mm  |         | 1.0 mm     |         | 4.0 mm  |         |
| 50%                            | 100%  | 50%     | 100%    | 50%        | 100%    | 50%     | 100%    |
| 6.6 mm                         | 13 mm | 17.7 mm | 24.1 mm | 8.2 mm     | 16.1 mm | 17.6 mm | 25.5 mm |
| II. Redondo Beach Slotted Mesh |       |         |         |            |         |         |         |
| Diversion                      |       |         |         | Efficiency |         |         |         |
| 1.2 mm                         |       |         |         | 1.2 mm     |         |         |         |
| 50%                            |       | 100%    |         | 50%        |         | 100%    |         |
| 17.9 mm                        |       | 23.7 mm |         | 19.2 mm    |         | 24.4 mm |         |

**Laboratory Study – ESEERCO**

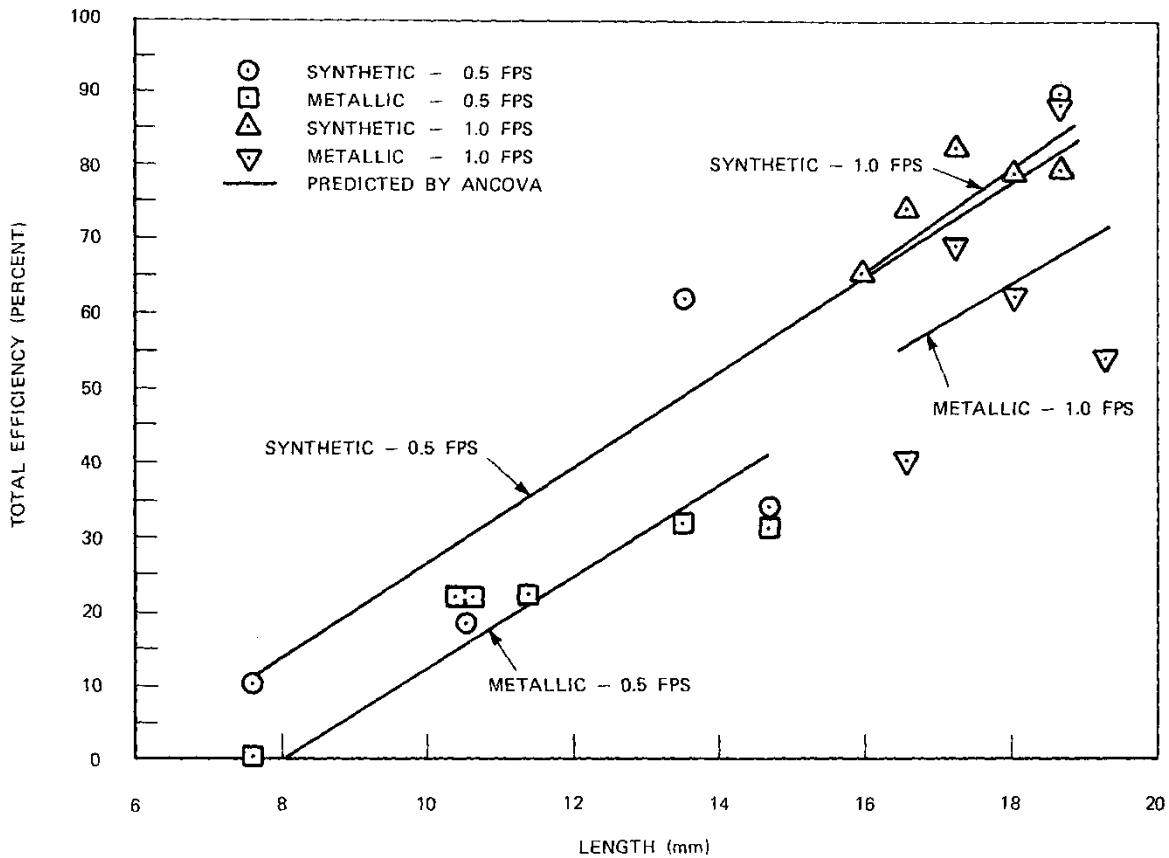
Fine-mesh angled screen diversion tests were conducted with larval fish in a smaller flume facility at Alden (ESEERCO 1981b; Taft et al. 1981b). These studies were conducted to determine the potential effectiveness of angled fine-mesh diversion screens for application at CWISs. Testing procedures differed slightly from 1978 (see previous case study) to 1980. Therefore, we present the results of 1978 and 1979 striped bass (*Morone saxatilis*) tests and 1980 winter flounder (*Pseudopleuronectes americanus*), alewife (*Alosa pseudoharengus*) and yellow perch (*Perca flavescens*) tests individually below.

In 1978, a total of 101 tests were conducted with striped bass larvae under both light and dark conditions. Since the 42 tests conducted under dark conditions more accurately represent conditions that would exist at a power plant, only these tests were subjected to analysis. Eleven tests were conducted with the 1.5 mm (0.06 in.) synthetic screen, 10 tests each with the 1.5 mm (0.06 in.) metallic and 2.5 mm (0.1 in.) synthetic screen, and 11 tests with the 2.5 mm (0.1 in.) metallic screen. The measure of success of the screens in diverting larvae without mortality was Total Efficiency (TE), defined as diversion efficiency adjusted for 96-hour mortality among successfully diverted larvae.

Results of testing under all conditions are presented graphically on Figure 10-10 and Figure 10-11 for the 1.5 mm (0.06 in.) and 2.5 mm (0.1 in.) meshes, respectively. As the figures show, TE increased with increasing larval length, as expected. Results of an analysis of covariance (ANCOVA) indicated that mesh size and type significantly influenced TE, with the 1.5-mm (0.06-in.) mesh yielding greater efficiencies than the 2.5-mm (0.1 in.) mesh and the synthetic mesh yielding higher diversion efficiencies than the metallic mesh. The predicted TE lines (Figure 10-10 and Figure 10-11) indicate a slightly higher efficiency at 0.3 m/sec (1.0 ft/sec) than at 0.2 m/sec (0.5 ft/sec). However, this is believed to result from the fact that the 0.3 m/sec (1.0 ft/sec) approach velocity was not tested until the larvae had reached a length of almost 15 mm (0.6 in.).



**Figure 10-10**  
**Total efficiency versus length for 1.5 mm mesh 1978 striped bass diversion study (Taft et al. 1981b)**



**Figure 10-11**  
**Total efficiency versus length for 2.5 mm mesh 1978 striped bass diversion study (Taft et al. 1981b)**

Based on results of testing in 1978, only synthetic meshes were evaluated with striped bass in 1979, and larger mesh sizes were added to the study. A total of 203 tests were analyzed: 29 with a 1.0 mm (0.04 in.) mesh, 38 with a 4.0 mm (0.15 in.) mesh, 70 with a 5.0 mm (0.2 in.) mesh, and 66 with a 9.5 mm (0.37 in.) mesh. Testing was conducted in a sequential manner beginning with the smallest mesh and lowest velocity. Once diversion was observed, the next largest mesh size and velocity were added to the testing regime. All tests were conducted under dark conditions. During the testing period, the striped bass grew from 9.9 to 41.1 mm (0.4 to 1.6 in.) in length.

We present the results of 1979 testing in Table 10-5, which summarizes the larval lengths at which total efficiencies of 25, 50, and 100% are predicted to occur (based on the ANCOVA model).

**Table 10-5**  
**Results of 1979 testing showing predicted efficiencies based on larval lengths (Taft et al. 1981b)**

| Mesh Size (mm) | Range of Larval Lengths (mm) Tested | Predicted Total Efficiency (TE) |         |         |
|----------------|-------------------------------------|---------------------------------|---------|---------|
|                |                                     | 25%                             | 50%     | 100%    |
| 1.0            | 9.9–18.0                            | --                              | 8.2 mm  | 16.1 mm |
| 4.0            | 10.4–24.7                           | 13.6 mm                         | 17.6 mm | 25.5 mm |
| 5.0            | 16.3–31.7                           | --                              | 20.0 mm | 32.1 mm |
| 9.5            | 18.0–41.1                           | 22.8 mm                         | 28.8 mm | 41.0 mm |

In general, these results are similar to those obtained in 1978: TE increased with larval length (i.e., as swimming ability increased). As expected, mesh size influenced TE in such a way that the larval length at which a specific efficiency value was achieved increased with each successive increase in mesh size.

A separate analysis was conducted to evaluate the effect of approach velocity on the TE obtained with each mesh size. Again, at a specific larval length, TE decreased with increasing mesh size. TE also decreased with increasing velocity at each mesh size.

Angled screen diversion studies were conducted with winter flounder (*Pseudopleuronectes americanus*), alewife (*Alosa pseudoharengus*), and yellow perch (*Perca flavescens*) larvae in 1980. Winter flounder were only available for testing over a 4.1 to 6.1 mm (0.16 to 0.24 in.) length range. In four tests, no diversion was noted.

Alewife prolarvae (mean length of 5.5 mm [0.21 in.]) and early postlarvae (mean length of 9.5 mm [0.4 in.]) also showed no ability to guide along the angled screen in single tests with the 1.0 mm (0.04 in.) screen at 0.152 m/sec (0.5 ft/sec). Later postlarvae showed relatively high diversion efficiencies. In two tests with 11.2 mm (0.44 in.) larvae, diversion efficiencies were 84 and 77%. In three tests with 14.7 mm larvae, efficiencies of 84, 84, and 60% were obtained. However, in all five tests, 96-hour mortalities were high, and total efficiencies were, therefore, low (less than 27%). The majority of postlarvae tested were observed to impinge on the 1.0 mm (0.04 in.) mesh for varying periods of time prior to being diverted into the bypass. Since control mortality was low, it would appear that stress from impingement contributed to the high mortalities that occurred.

As with the other species, smaller yellow perch larvae (mean lengths of 6.0 and 9.3 mm) showed no ability to guide along the 1.0 mm (0.04 in.) mesh at 0.152 m/sec (0.5 ft/sec) (six tests). In two tests with 14.3 mm (0.56 in.) perch, diversion efficiencies of 16 and 72% were obtained. Respective 96-hour mortalities were 11.1 and 1%. Further testing was not possible since additional yellow perch larvae were not available.

### **Laboratory Study – Tennessee Valley Authority**

Two years of studies by TVA (TVA 1980) examined the ability of several species of larval fish to avoid impingement and/or entrainment in flowing water, using a stationary stainless steel screen with wedge-shaped wire. Information generated by these studies is significant in that the



studies examined closely the interaction of fish with limited swimming ability and a screen set at different orientations under various flow conditions.

During the first year of study, seven species of fish larvae ranging from 5.6 to 21.5 mm (0.2 to 0.8 in.) in length were tested. Results of 296 separate test conditions showed that except for the very young of one species, all larvae exhibited the ability to avoid entrapment for all three slot widths (0.5, 1.0 and 2.0 mm [0.02, 0.04, and 0.08 in.]), thus confirming that many larval species have the ability to guide along screens.

During the second year of study, larvae of nine species ranging in length from 5.7 to 14.7 mm (0.2 to 0.6 in.) were tested in 243 tests. Results of the study are briefly highlighted below:

1. Slot velocity had a highly significant effect on avoidance. Mean avoidance at slot (through-screen) velocity of 0.075 m/sec (0.25 ft/sec) (80.5%) was significantly greater than at 0.15 m/sec (0.5 ft/sec) (14.9%) for Northern pike (*Esox lucius*) larvae.
2. The effect of slot orientation (vertical versus horizontal) was species-dependent. Greater avoidance occurred with the vertical slot orientation for white sucker (*Catostomus commersonii*), channel catfish (*Ictalurus punctatus*) and sauger (*Sander canadensis*), whereas striped bass/white bass hybrid (*Morone saxatilis* x *Morone chrysops*) larvae and largemouth bass (*Micropterus salmoides*) larvae showed significantly greater avoidance with the horizontal orientation.
3. The slot velocity by slot orientation interaction effect was significant for white sucker and channel catfish. In each case, the effect of slot orientation was greater at the lower slot velocity. At the high velocity, fish apparently have little chance of escaping once contact is made, regardless of slot orientation. At the lower slot velocity, the probability of escaping was greater with the vertical slot orientation. This was expected, since the slot was oriented perpendicular to the length of the fish.
4. Significantly higher mean avoidance was observed for low slot velocity, vertical slot orientation, and daylight among paddlefish and walleye larvae. Both species were more vulnerable to entrapment by the horizontal slot screen at night.
5. All species except channel catfish showed significantly higher mean avoidance during daylight tests. This was considered to be consistent with described habits of this nocturnal species. Thus, orientation to visual stimuli appeared important in the overall avoidance response.
6. Results of experiments conducted with striped bass/white bass hybrid indicate that mean avoidance during daylight (77.8%) was significantly greater than during night (28%).
7. For white sucker, avoidance appeared related to visual stimuli (daylight) and was strongest for the 0.04 in. mesh (1.0 mm) screen.
8. Slot velocity and slot width had a significant effect on avoidance. Higher avoidance was associated with lower slot velocity and narrow widths for channel catfish, bluegill (*Lepomis macrochirus*), and walleye (*Sander vitreus*).
9. Significantly higher avoidance occurred for white sucker and channel catfish for low slot velocity and availability of a bottom refuge.

10. Avoidance was related to fish age for white sucker, striped bass, and sauger. Significantly higher avoidance for low slot velocity and older fish was obtained.

The results of this study indicated that "fish avoidance" at water intake screens has high potential for protecting a large percentage of fish larvae that could potentially be entrapped. All variables that were tested represented important design parameters for a prototype screen. In addition, large differences in avoidance among species and ages dictate the need to consider species and sizes of fish available at a particular site when designing an intake of this type (TVA 1980).

The tests indicated that to provide optimum protection for very small larvae (<6.0 mm [ $<0.24$  in.] total length), a screen slot width of 0.5 mm (0.02 in.) and a slot velocity no greater than 0.075 m/sec (0.25 ft/sec) may be required.

The study concluded that use of a 1.0-mm (0.04-in.) slot and sufficiently low through-screen velocity would probably enable all larvae over 10-mm (0.4-in.) total length to avoid entrapment. For some species, a through-screen velocity as high as 0.15 m/sec (0.5 ft/sec) would not appreciably reduce avoidance, but for others, it would be necessary to limit slot velocity to 0.075 m/sec (0.25 ft/sec). Several species between 7- and 10-mm (0.3- and 0.4-in.) total length could probably avoid a screen of 1.0-mm (0.04-in.) slot width if through-screen velocity was limited to 0.075 m/sec (0.25 ft/sec). For some species, slot orientation and lighting may need to be considered in order to optimize avoidance (TVA 1980).

In addition, a screen with 0.1-in. (2.0-mm) wide slots could be used to effectively protect most species of larvae which exceed 0.4-in. (10-mm) in length. With this slot size, use of low slot velocity (7.6 cm/sec [0.25 ft/sec]) and orienting the slots perpendicular to flow direction may be required to optimize avoidance for most species. Higher slot velocity could be used and still provide adequate protection for juvenile and larger fish during periods when larvae are not present. Inclusion of a bypass area located below the screen (in the case of a vertical flat screen oriented parallel to flow direction) probably would increase avoidance for nearly all species (TVA 1980).

### ***Laboratory Study – Alden Research Laboratory***

A variety of laboratory studies have been conducted that indicate that an angled diversion screen concept is effective in diverting larval, juvenile, and adult fishes to bypasses. These studies led to the development of angled screen diversions and fish transportation systems that were incorporated into the design of two large power plants situated on Lake Ontario, one plant on the Hudson River, and one coastal plant in Massachusetts.

Laboratory studies were conducted at Alden Research Laboratory, Inc., (Alden) to evaluate the potential biological effectiveness of angled screens for three power generators. During the 4 years of development, three experimental flumes were used to evaluate the screen over a wide range of environmental and engineering conditions. Variables investigated included test species, temperature, approach and bypass velocity, light conditions, and the mortality associated with diversion (Taft and Mussalli 1978). We provide a summary of the physical and biological parameters investigated in each test flume in Table 10-6.

**Table 10-6**  
**Physical and biological parameters investigated in each test flume (Taft and Mussalli 1978)**

| Test Parameters                                                             | Niagara Mohawk<br>3-ft flume                       | Niagara Mohawk/<br>Rochester Gas & Electric<br>6-ft flume               | Con Edison<br>6-ft flume                                                                   |
|-----------------------------------------------------------------------------|----------------------------------------------------|-------------------------------------------------------------------------|--------------------------------------------------------------------------------------------|
| Test species and temperature range, in degrees Fahrenheit (degrees Celsius) | alewife: 78–49<br>(26–10)<br>smelt: 37–36<br>(3–2) | alewife: 82–39<br>(28–4)                                                | striped bass: 77–35<br>(26–2)<br>white perch: 77–52<br>(26–11)<br>tomcod: 36–55<br>(2–1.5) |
| Approach velocities, in ft/s(m/s)                                           | 1.0<br>(0.3)                                       | 0.5, 0.8, 1.0, 1.5, 2.0, 3.0<br>(0.15, 0.24, 0.31, 0.46,<br>0.06, 0.92) | 0.5, 1.0, 1.5, 2.0, 2.5,<br>3.0<br>(0.15, 0.31, 0.46, 0.61,<br>0.76, 0.92)                 |
| Bypass velocities, in ft/s<br>(m/s)                                         | 1.4<br>(0.423)                                     | 0.5, 0.8, 1.0, 1.5, 2.0, 3.0<br>(0.15, 0.24, 0.31, 0.46,<br>0.06, 0.92) | 0.5, 1.0, 1.5, 2.0, 2.5,<br>3.0<br>(0.15, 0.31, 0.46, 0.61,<br>0.76, 0.92)                 |
| One week mortality studies                                                  | No                                                 | Yes                                                                     | Yes                                                                                        |
| Number of tests                                                             | 7                                                  | 36                                                                      | 32                                                                                         |
| Screen mesh                                                                 | 1/4 (6.4 mm)<br>14 gage                            | 3/8 in. (9.5 mm)<br>11 gage                                             | 3/8 in (9.5 mm)<br>11 gage                                                                 |
| Flume dimensions<br>W by D by L, in feet<br>(meters)                        | 3 by 3 by 70<br>(0.91 by 0.91 by<br>21)            | 6 by 6 by 40<br>(1.8 by 1.8 by 12)                                      | 6 by 7 by 80<br>1.8 by 2.1 by 24)                                                          |
| Flume flow capacity, in<br>cfs (m <sup>3</sup> /sec)                        | 12<br>(0.34)                                       | 130<br>(3.68)                                                           | 110<br>(3.11)                                                                              |

Each test consisted of placing from 100 to 2,000 fish, ranging in length from 25 to 150 mm (1 to 6 in.), in a test flume under the desired conditions and allowing them to react naturally. After being diverted, the fish were removed from a bypass collection area and held for up to 1 week

for observations of latent mortality. A separate control group was held for comparison. In this way, differential (test minus control) mortalities were determined.

Initial studies for Niagara Mohawk were conducted in a flume that was 21.3 by 0.9 by 0.9 m (70 ft by 3 ft by 3 ft). These studies were designed to obtain a preliminary indication of the effectiveness of a 25 degree angled screen in diverting alewife (*Alosa pseudoharengus*) and rainbow smelt (*Osmerus mordax*) to a 152.4 mm (6 in.) wide bypass (Taft and Mussalli 1978). In seven tests with over 2,000 fish, diversion efficiencies for both species were nearly 100%. Therefore, it was decided to conduct a further evaluation of the concept with alewife in a large-scale flume in which all of the details of a prototype screen could be closely simulated.

The large-scale flume was approximately 12.2 by 1.8 by 1.8 m (40 by 6 by 6 ft) and incorporated a 3.7 m (12 ft) long angled screen leading to a 152.4 mm (6 in.) wide bypass. Simultaneously, a third flume with similar dimensions was constructed for Con Edison to determine the potential of the angled screen concept for effectively diverting Hudson River species.

Results of testing in both large-scale flumes were similar (Taft and Mussalli 1978). In most cases, the 25 degree angled screen was found to be 100% effective in diverting all test species (alewife [*Alosa pseudoharengus*], white perch [*Morone americana*], striped bass [*Morone saxatilis*], and Atlantic tomcod [*Microgadus tomcod*]) to the bypass under all test conditions. The results of latent mortality studies showed a mean differential mortality and 95% confidence limits of  $35.7 \pm 13.5\%$  for alewife (25 tests) and  $3.3 \pm 2.5\%$  for Hudson River species (32 tests).

The relatively high mortality observed among alewife was assumed to be largely attributable to the difficulty in handling this fragile species in the model facility. This assumption was verified in later studies in which the angled screen bypass was connected to a fish transportation system. The system consisted of a 54.9 m (180 ft) long, 25.4-cm (10-in.) diameter pipe and 30.5 cm (12 in.) diameter jet pump that discharged into a large stilling basin where mortality could be observed without handling. Since the pipe and jet pump were tested at velocities up to 2.8 m/sec and 15.2 m/sec (9 ft/sec and 50 ft/sec), respectively, it would be assumed that mortalities in the system would be higher than those observed in studies with the angled screen alone, due to the additional stresses imposed.

However, the results of 11 tests in the combined angled screen and fish transportation system model showed mean test and control mortalities of 11.8% and 7.8%, respectively, resulting in a mean differential mortality of only 4%. Therefore, this value is considered to be a better estimate of the most probable mortality that might be expected to occur in a prototype angled screen application.

Tests were also conducted to study the distribution of trash on the screen and to determine the percentage of trash entering the bypass. Three tests with approach and bypass velocities of about 0.31 and 0.15 m/sec (1.0 and 0.5 ft/sec) were performed. Test results indicated that the distribution of trash between the screen and the bypass follows the distribution of flow. The majority of the trash became lodged on the screen face at the point of initial contact.

Considering the high diversion efficiencies and low resultant mortalities obtained with the angled screen in the laboratory, Niagara Mohawk installed the full-scale angled screen and fish transportation system at the Oswego Steam Station on Lake Ontario, as we discussed previously.

### **Laboratory Study - California**

Early angled screen evaluations were conducted in an experimental flume for the Southern California Edison's San Onofre Station (Schuler 1973; Schuler and Larson 1975). In these studies, 1.6 cm (5/8 in.) mesh screens were found to yield poor-to-fair guidance (0 to 70%) of the Northern anchovy (*Engraulis mordax*), a primary test species. Moderate-to-good guidance (60 to 90%) of other test species was obtained with a screen set at 45 degrees to the approach flow, an approach velocity of 0.6 m/sec (2.0 ft/sec), and a bypass velocity of 0.45 to 1.2 m/sec (1.5 to 4.0 ft/sec) (higher efficiencies corresponded to higher bypass velocities). This was also the best setting for anchovies, which were guided with 30 to 70% efficiency. Further improvement of the angled screen design was not attempted since a decision was made to pursue louvers for this site. It is likely, however, that improved design and hydraulic conditions would have led to high diversion efficiencies, as witnessed by other investigators who developed the angled screen concept further.

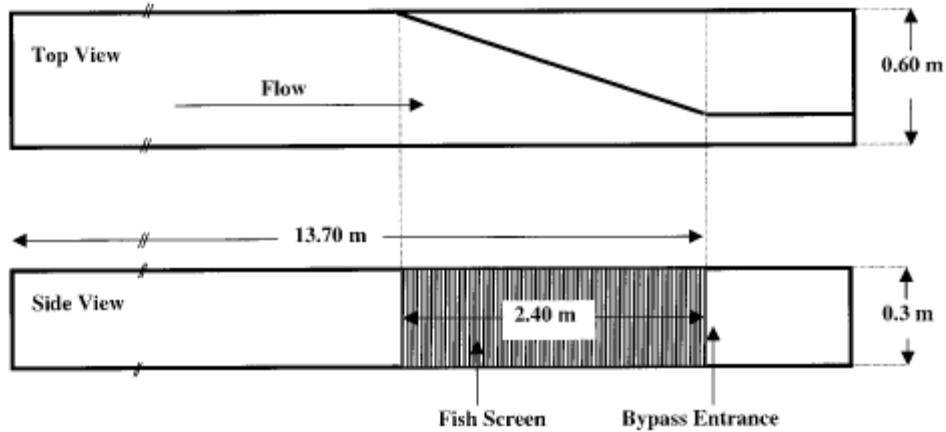
### **Laboratory Study – University of California, Davis**

Screening facilities were constructed at the State Water Project (SWP) and the Central Valley Project (CVP) to reduce their potential effects on San Joaquin Delta fish, particularly the Sacramento splittail (*Pogonichthys macrolepidotus*) (Swanson et al 1998). Fish are diverted away from the pumps through a series of bypass screens and louvers into holding tanks. Fish are then transported from the holding tanks to other regions of the southern delta.

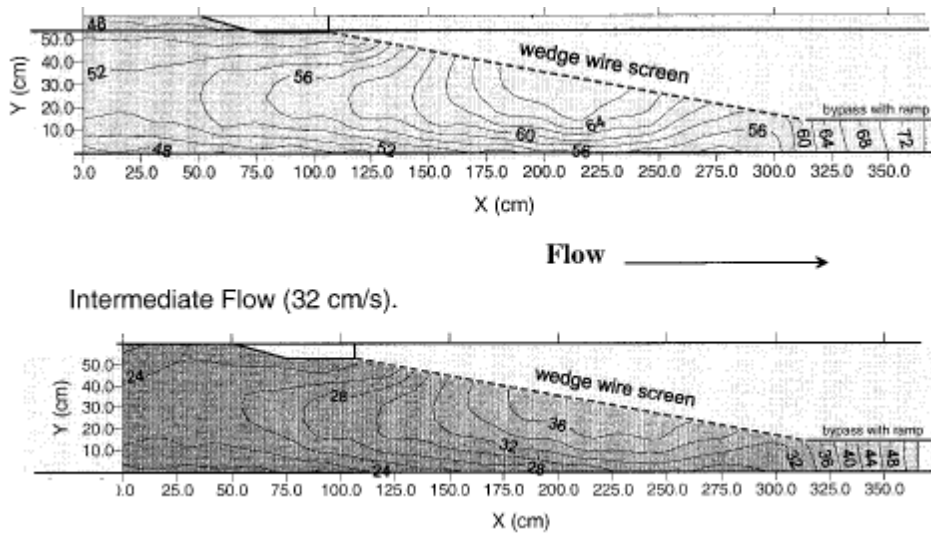
A study was conducted to investigate the swimming performance and physiological responses of small age-0 splittail exposed to a wedge-wire fish screen. Four velocity treatments, found to be common at the CVP and SWP diversions, were tested within a model water diversion facility flume. The objective was to determine if fish screen exposure contributed to increased sublethal effects (physical or physiological) and mortality, and whether these responses were a function of water velocities in front of the screen. It is hypothesized that this study would result in: (1) random rheotaxis, increased screen contacts, and losses of equilibrium; (2) elicit acute physiological changes (increased hematocit, plasma glucose, and plasma lactate); and (3) contribute to increased mortality.

The test flume was equipped with a stainless steel, vertical wedge-wire (0.12 cm bar interval) fish screen angled 10 degrees from the flume wall and bypass channel (Figure 10-12). Stainless steel wire mesh screens were also used to enclose the swimming chamber at both the upstream and downstream end. The mean depth was 15.4 cm (0.5 ft) and a mean water temperature of 12.4°C.

Splittail (mean SL= 5.9 ± 1.3 cm) were acclimated to the 12°C water chamber temperature for a period of 24-hrs. Fish were then subjected to a velocity acclimation within a 1.8- by 0.6-m (5.9 by 2 ft) section of the swimming chamber for 0.5 hrs. There was no flow for the first 0.25 hr and then velocities were increased to 25 cm/sec ± 5 cm/sec (9.8 in/sec ± 2 in/sec) for the second 0.25 hr (no flow again for controls). Fish were released into the test flume for 1.5 hrs within one of four water velocity treatments: control (0 cm/sec mean resultant velocity in front of the screen); intermediate (32 cm/sec [12.6 in/sec]); and two high velocity (60 cm/sec[23.6 in/sec]) treatments each with a different bypass entrance velocity (low = 50 cm/sec [19.7 in/sec], high = 72 cm/sec [28.3 in/sec]). Velocities varied depending on the position and location within the test flume (Figure 10-13). Three replicate experiments were conducted per treatment, each with 20 fish.



**Figure 10-12**  
**Diagram of the open-topped, glass water flume swimming chamber and bypass channel**



**Figure 10-13**  
**Flow maps of water velocities at middepth (8 cm) in the high-velocity, high-bypass (60 cm/s with a 72 cm/s bypass) and intermediate-velocity (32 cm/sec) treatments near the fish screen. The x-axis indicates distance along the length of the flume, the y-axis indicates width, and the contour lines indicate water velocities (cm/sec).**

Swimming performance observations during each experiment included, screen contacts, equilibrium loss, the number of fish entering the bypass, and survival. Screen contacts were measured in one of two ways: (1) tail touches (screen contact with the caudal fin and an angle of the body length to screen of  $>45$  degrees); (2) body touches (screen contact by greater than half of the body length and an angle of the body to the screen  $\leq 45$  degrees). Results were measured in the total number of screen contacts per experiment. Loss of equilibrium was defined as a body roll greater than 90 degrees. All swimming velocities were calculated using the following formula:

$$V = v_f + v_w \text{ or } V = v_f - v_w$$

Where  $V$  is the swimming velocity of the fish through the water,  $v_f$  is the swimming velocity of the fish over the ground, and  $v_w$  is the water velocity. Water velocities were added when fish were positively rheotaxic (swimming upstream), and subtracted when fish were negatively rheotaxic (swimming downstream).

Fish entering the bypass during a noncontrol test, were removed and 5 fish were randomly placed into one of four hematological groups: 0, 0.5, 2, and 24 hrs. Blood was collected immediately from 0 h fish, while the remaining sample groups were held in continuously water flowing tanks until the fish's respective post experimental sampling time. Fish not entering the bypass and control fish were bled or taken for hematological sampling immediately following the end of each experiment. Plasma samples held for analyses of plasma lactate and glucose concentrations using a glucose-lactate analyzer.

One-way analysis of variance (ANOVA) with treatment velocity as the single factor was used to compare treatments. A two-way ANOVA was used to test the physiological responses among treatments, with the physiological response and time as the two main factors.

Screen contacts, both tail and body did not differ significantly among treatments, averaging less than 1 fish/hr (Table 10-7). Swimming velocities were found to increase with water velocity, with splittail in high/low and high/high velocity treatments swimming significantly faster than splittail in medium or control treatments. Fish continued to swim at velocities slightly lower than actual water velocities for the intermediate and high velocity treatments. Mean splittail swimming velocities (up to 52.3cm/sec) were higher than the velocity found in earlier studies (~27 cm/sec). Differences in study design may be held accountable for these differences; this includes numbers of fish used per experiment and swimming chamber type. These results indicate the juvenile spittail can swim faster than velocities found at the SWP and CVP diversion facilities. Spittail were also found to adjust their swimming velocities with treatment while still avoiding the screen. 60-80% of fish were able to remain on the upstream end of the chamber and avoid the screen for the duration of the experiment. This station-holding ability and positive rheotaxis suggests the fish would have been able to completely avoid the screen had they not be restrained by the flume boundaries. 20–40% of the fish per experiment entered the bypass regardless of velocity treatment and may explain the high numbers (almost 10,000 in June 1997) of splittail collected at the SWP and CVP facilities in abundant years.

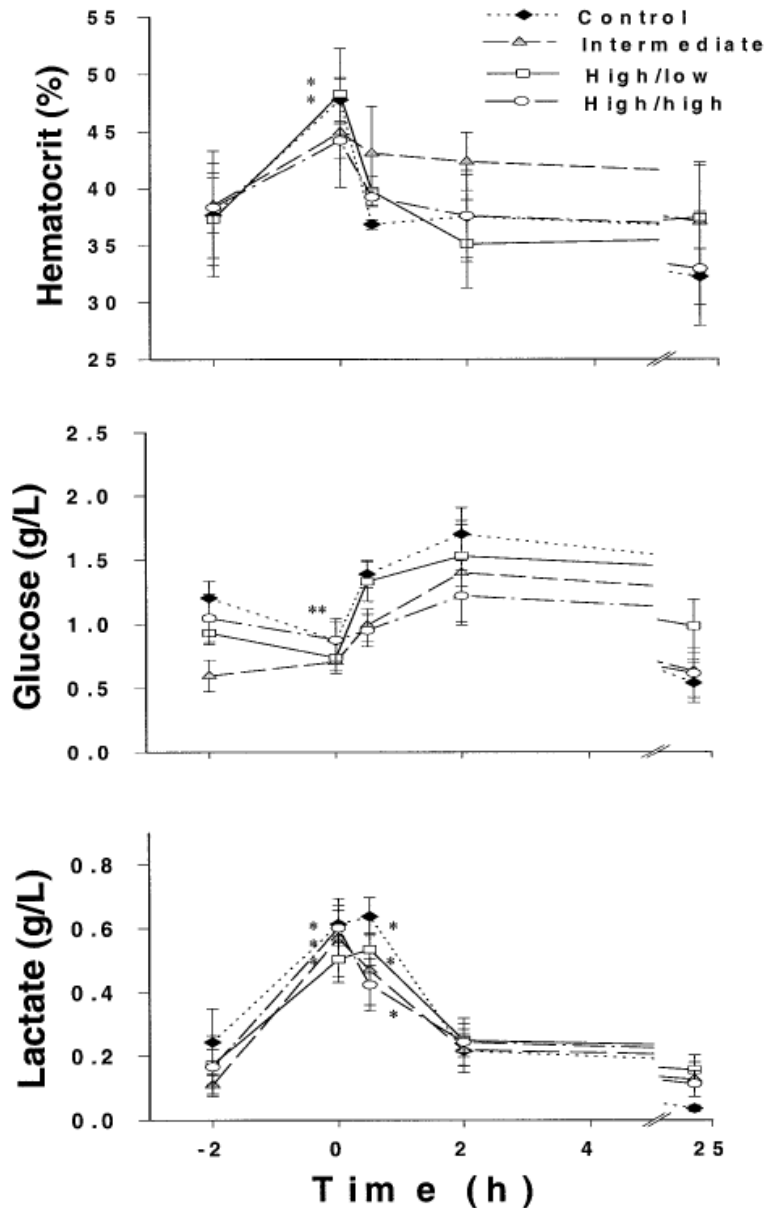
**Table 10-7**

**Total number of tail contacts (T), total number of body contacts (B), swimming velocity (cm/sec, V), total number of fish entering the bypass (E), and rheotaxis (angle of fish to flow, R) of age-0 splittail exposed to a linear, wedge-wire fish screen. Four velocity treatments were tested: control (0 cm/sec flume and bypass), intermediate (32 cm/sec flume and bypass), high-low (60 cm/sec flume and 50 cm/sec bypass), and high-high (60 cm/sec flume and 72 cm/sec bypass). Results are presented as the mean  $\pm$ SE of three replicates per treatment and are based on either direct observations of 20 fish (T, B, and E) or video analyses of 5 fish (V and R) per replicate. Response means followed by a common letter were not significantly different at  $P < 0.05$  using a one-way analysis of variance with 3 df.**

| <b>Treatment</b> | <b>T</b>     | <b>B</b>    | <b>V</b>        | <b>E</b>   | <b>R</b>      |
|------------------|--------------|-------------|-----------------|------------|---------------|
| Control          | 2 $\pm$ 2z   | 0 $\pm$ 0z  | 18.8 $\pm$ 3.5z |            | 122 $\pm$ 12z |
| Intermediate     | 5 $\pm$ 3z   | 3 $\pm$ 3z  | 26.5 $\pm$ 4.2z | 4 $\pm$ 3z | 62 $\pm$ 18y  |
| High-low         | 7 $\pm$ 2z   | 4 $\pm$ 4z  | 52.3 $\pm$ 1.2z | 7 $\pm$ 2z | 20 $\pm$ 6y   |
| High-high        | 28 $\pm$ 12z | 14 $\pm$ 9z | 47.1 $\pm$ 3.0z | 8 $\pm$ 4z | 18 $\pm$ 7y   |

Rheotaxis was found to be significantly different for all treatments compared to controls and positive for intermediate and high velocity treatments. Time-dependent physiological responses were detected among fish from all treatments, but no velocity-dependent differences were found. Stress responses among all treatments indicate that the responses must have arose from something other than the treatment, such as capture and handling at the end of the study. Hematocrit levels (%) increased following treatment and removal from the flume and were then found to decrease to near-resting levels by the end of the study (Figure 3). Plasma glucose levels (g/L) increased following velocity treatment and were significantly higher for the control treatment group at 2 h (Figure 3). Glucose responses displayed typical acute responses, consistently peaking at the 2-h sample before returning to near-resting levels at 24-h sample (Figure 3). Plasma lactate levels (g/L) increased immediately following velocity treatment and were significantly different from resting levels. The displayed lactate levels were the typical response to an acute stressor. These levels are can indicate the use of anaerobic metabolism due to fight-or-flight responses as would be expected with fish trying to avoid net capture.





**Figure 10-14**  
 Mean ( $\pm$ SE) splittail hematocrit (%), plasma glucose (g/L), and lactate concentrations (g/L) at rest and without flume exposure (-2 h), immediately after swimming in the flume (0 h), and during recovery (0.5, 2, and 24h) for each velocity treatment. Significant differences ( $P < 0.05$ ) are indicated by asterisks (\* = higher from -2 h; \*\* = control lower than 2 h).

Under the conditions explored in this study it does not appear that screen exposure is related to mortality at the diversion screening facilities. The experimental results did not find inadequate swimming performance, elicit a velocity-dependent stress response, or result in increased mortality.



# 11

## HIGH-VELOCITY SCREENS

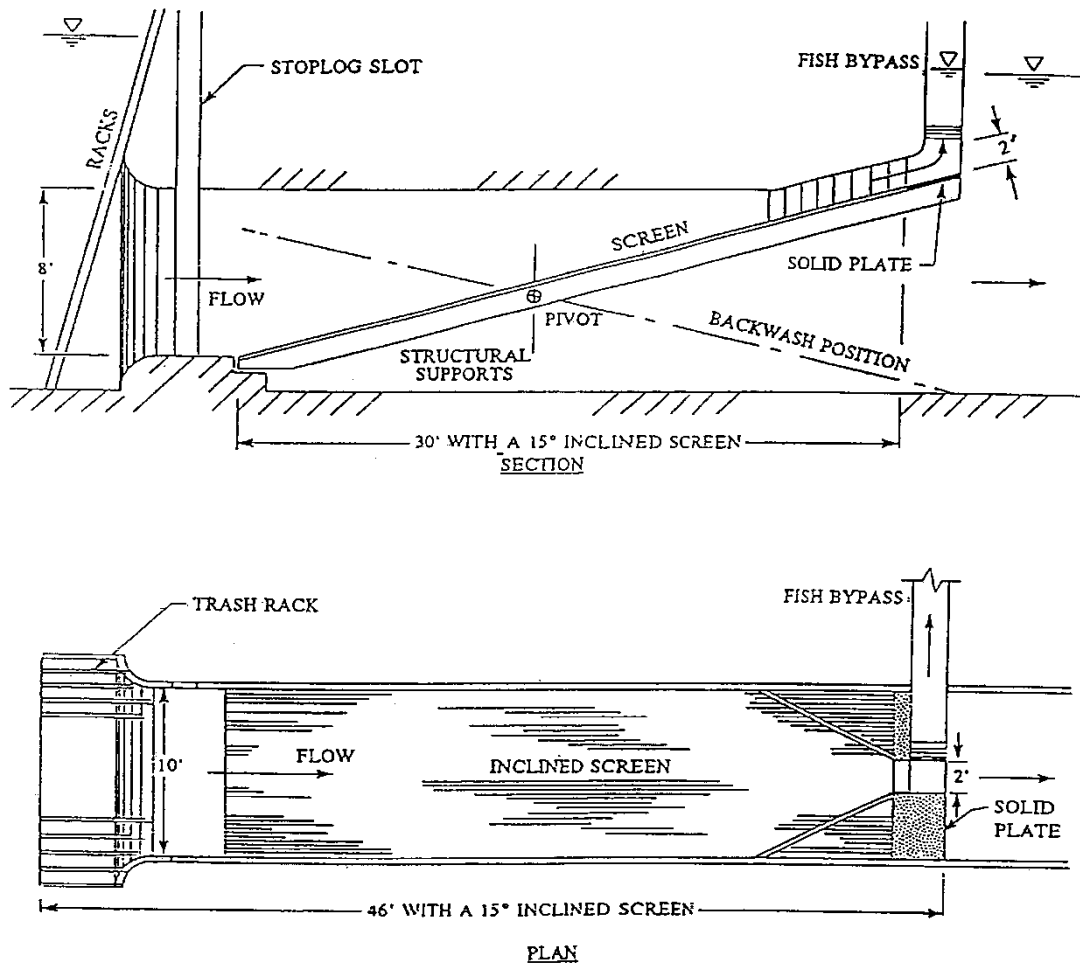
### Introduction

High-velocity screens include both the Modular Inclined Screen (MIS) and the Eicher screen. To date there has been no application of these types of screens at CWIS, but the Eicher screen has been used at several hydroelectric power plants.

### Modular Inclined Screens (MIS)

The MIS (Figure 11-1) was developed and tested in the 1990s (EPRI 1994b, 1996; Alden and SWEC 1996; Amaral 1999). The MIS is intended to protect juvenile and adult life stages of fish at all types of water intakes. An MIS module consists of an entrance with trash racks, dewatering stop logs in slots, an inclined screen set at a shallow angle (10 to 20 degrees) to the flow, and a bypass for directing diverted fish to a transport pipe. The module is completely enclosed and is designed to operate at relatively high water velocities ranging from 0.6 to 3.0 m/sec (2 to 10 ft/sec), depending on species and life stages to be protected. To date, the MIS has undergone extensive evaluation in the laboratory and at a prototype field site.

The MIS has yet to be used on a permanent basis to protect fish at water intakes. However, the combined results of laboratory and field evaluations of the MIS to date have demonstrated that this screen is an effective fish diversion device that has the potential for protecting juvenile and adult fish at water intakes. Given the large number of species that has been evaluated, covering a wide range of swimming capabilities and body shapes, it is reasonable to assume that juvenile and adult life stages of many species may be diverted and survive within the range of net passage survivals observed in the laboratory and field studies. Although the MIS screen material is constructed of narrow-bars closely spaced (2-mm bars spaced at 2 mm (0.08 in.)), the effect of the screen on eggs, larvae, and early juveniles with limited swimming capabilities has yet to be determined. Given the high velocities used in this screen design, non-motile life stages that cannot pass freely through the screen slots could be subject to impingement and injury. Therefore, prototype evaluations of the MIS are needed before the effectiveness of this technology for CWIS application can be determined.



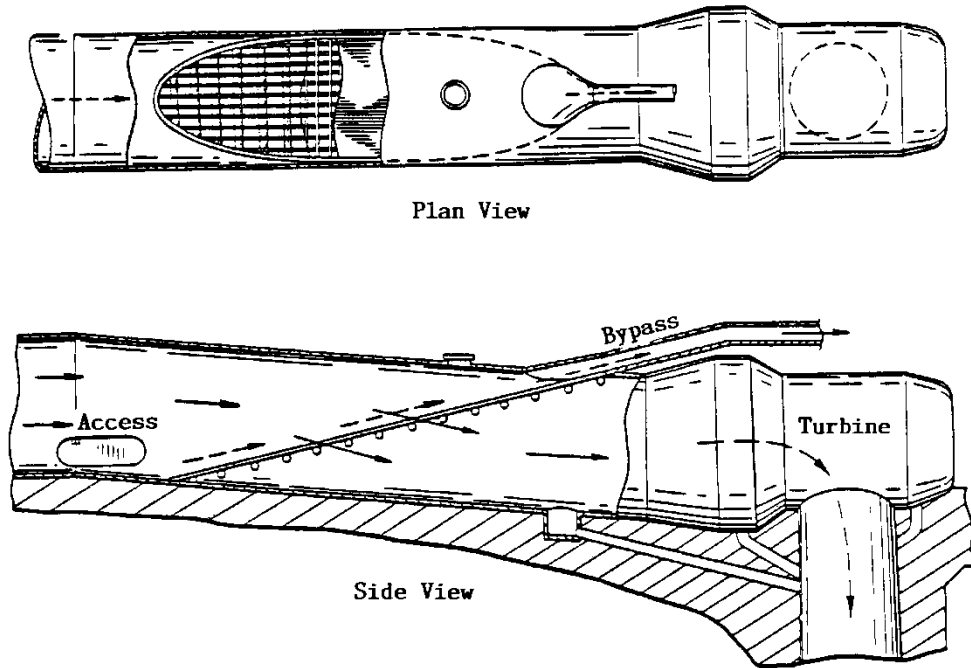
**Figure 11-1**  
**Modular inclined screen (Taft et al. 1995)**

## Eicher Screens

The Eicher screen is a passive-pressure screen designed for application at hydroelectric facilities with penstocks. The concept was patented in the United States and Canada by George Eicher and is, therefore, commonly referred to as the "Eicher Screen." While the technology is not applicable to CWIS, a brief review of its current status is provided. The available biological information is pertinent to fish diversion screens in general (particularly the MIS) and should be included in any review of fish protection technologies.

The first Eicher Screen was installed at the T. W. Sullivan Hydro Plant on the Willamette River, Oregon in 1980. The facility incorporated a screen constructed of smooth-surfaced wedgewire material that inclines upward toward a fish bypass. The screen is mounted on a frame and pivot axis that allows the screen to be rotated and back flushed for cleaning. The screen has been reported to be effective in bypassing spring and fall Chinook salmon and steelhead with little injury or scale loss (Cramer 1997).

The second Eicher Screen was constructed and installed in a 2.7-m (9-ft) diameter penstock at the former Elwha Hydroelectric Project on the Elwha River in Washington. Field testing of the screen completed in 1990 and 1991 (EPRI 1992a) demonstrated that it effectively diverted over 98% of the steelhead, coho, and Chinook smolts (Figure 11-2).



**Figure 11-2**  
**Eicher Screen (EPRI 1992a)**

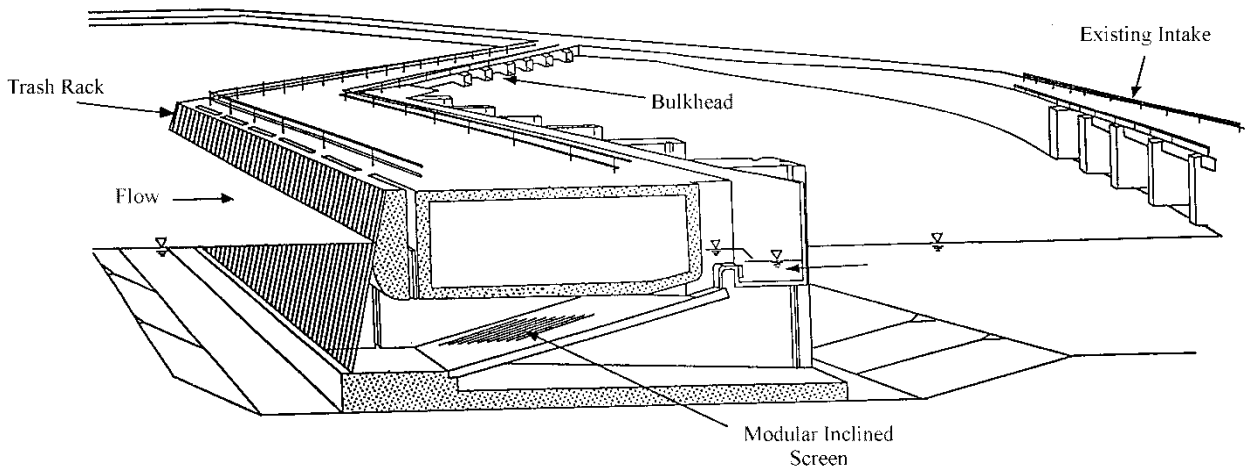
The Eicher Screen continues to be a viable option for protecting juvenile salmonids at hydroelectric projects. Given the similar results obtained during biological evaluations of the MIS (described above) with anadromous and potamodromous fish, it would appear that both screens have potential to divert a variety of species.

## **Case Studies – Hydroelectric Field Application**

### ***Green Island***

Based on previous laboratory results, a pilot-scale evaluation of the MIS (Figure 11-3) was conducted at Niagara Mohawk Power Corporation's Green Island Hydroelectric Project on the Hudson River near Albany, New York (EPRI 1996; Alden and SWEC 1996;). The results obtained in this field evaluation were similar to those obtained in laboratory studies. Golden shiners and rainbow trout showed diversion and survival rates approaching 100% under most test conditions. For blueback herring diversion efficiencies and extended survival values obtained were similar to laboratory results. In both cases, there was a relationship between diversion and survival and test velocity. Higher velocities resulted in lower diversion and survival rates.

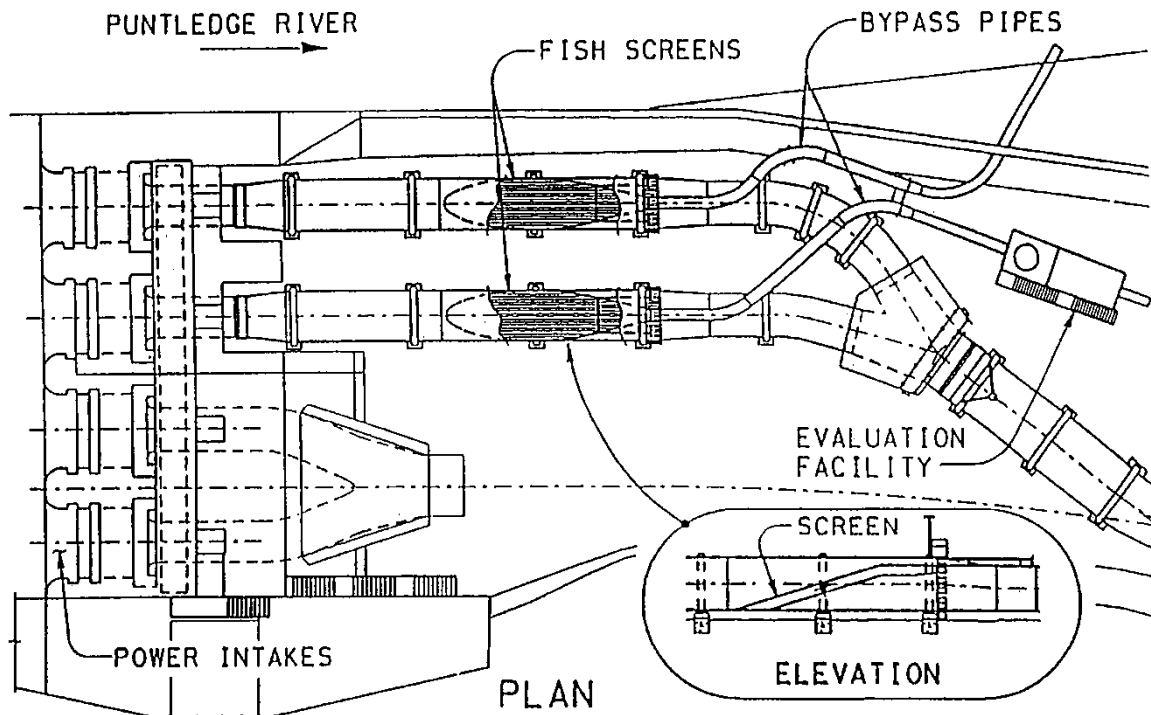
Additional studies at Green Island in 1996 showed high diversion efficiencies and low latent mortality of largemouth and smallmouth bass, yellow perch, and bluegill.



**Figure 11-3**  
**Schematic of modular inclined screens (Taft et al 1997)**

### ***Puntledge Hydroelectric Project***

At B.C. Hydro's Puntledge Hydroelectric Project on the Puntledge River, B.C., a number of past efforts to divert fish around the project's intake have proven largely unsuccessful. This situation led to the eventual installation of Eicher Screens (Smith 1997). The selection of the Eicher Screen was based on the excellent results of studies at the T. W. Sullivan Project (described above). Fish species of interest included steelhead trout, and Chinook, coho, pink, and chum salmon. A plan view of the Puntledge Eicher Screen System appears in Figure 11-4.



**Figure 11-4**  
**Puntledge Eicher Screen System (Smith 1997)**

The following criteria were applied during the design of the facility: the design fish were 37-mm (Chinook fry); the minimum hydraulic grade was 0.49 m; the design approach velocity was 1.8 m/sec (5.9 ft/sec), the ratio of screen sweeping velocity to normal velocity was 3:1; the maximum acceptable variation in velocity upstream of screen was 10%; the maximum acceptable variation in the normal velocity component was 20%; the screen angle was 16.5 degrees; the screen bar spacing was 2.5 mm; the bypass pipe had a diameter of 0.61 m; the velocity in the bypass pipe was 2.4 m/sec (8.0 ft/sec); and the minimum radius of the bypass pipe curvature was 6 diameters.

Biological evaluations of the Puntledge Eicher Screen System in 1993 and 1994 showed a bypass efficiency of 99% for coho and Chinook salmon smolts. Bypass efficiencies for steelhead trout, sockeye, and chum salmon fry were 100, 96, and 96%, respectively. From a reliability viewpoint, the screens performed well. There was little maintenance required for the Eicher Screen System. Routine trash rack cleaning and screen backwashing were the only common maintenance tasks.

### ***T. W Sullivan Plant***

Installation of a fish diversion screen inside of a closed penstock was first accomplished at the T.W. Sullivan Plant at Willamette Falls in October of 1980 (EPRI 1994b). The screen at the Sullivan Plant is located in a 3.3-m (11-ft) diameter penstock, is 6.4 m (21 ft) long and is inclined at a slope of 19 degrees to the flow. The wedgewire screen material has 2-mm (0.08-in.) bars and 2-mm (0.08-in.) openings between bars. The average water velocity through the

penstock is approximately 1.5 m/sec (5 ft/sec), and the average velocity normal to the screen face is approximately 0.45 m/sec (1.5 ft/sec). Only the inclined portion of the screen at the Sullivan Plant may be rotated for back flushing.

Despite poor hydraulic conditions imposed by the layout of the intake structure, evaluation studies conducted in 1981 with spring Chinook, fall Chinook, coho salmon, and steelhead trout smolts indicated that the screen had high diversion efficiencies. The percentage of marked fish recovered after passage through the facility ranged from 94.9 to 99.6% (Clark 1981). The investigator assumed that the few fish that were missing remained in the trapping facility.

Prior to 1991, accurate assessment of fish injury was precluded by injuries caused in the fish collection facility used for testing. In addition, roughness and obstructions in the penstock, transition, and fish bypass pipe may have been responsible for some of the injuries observed. Modifications have since been completed to reduce descaling potential from roughness and obstructions.

The collection facility was modified in the fall of 1991 and subsequent monitoring results have shown low injury and mortality rates. Injury data collected during 1991 and 1992 (Table 11-1) have not been adjusted for any scale loss present on the fish prior to passing through the screening facility.

**Table 11-1**  
**Number of fish and the percentage of fish descaled during observations made at the T.W. Sullivan Plant in 1991 and 1992 (Clark and Cramer 1993).**

| Species                 | Percent Descaled | Number Examined |
|-------------------------|------------------|-----------------|
| hatchery spring Chinook | 3.30             | 278,494         |
| wild spring Chinook     | 3.90             | 9,368           |
| hatchery steelhead      | 2.05             | 4,001           |
| wild steelhead          | 1.15             | 610             |
| coho                    | 1.41             | 71              |
| fall Chinook            | 3.11             | 2,144           |

In an update on the biological effectiveness of the Eicher Screen at the T.W. Sullivan Plant, Cramer (1997) reports that the screen continued to be effective in bypassing these species with little injury or scale loss.

### ***Elwha Hydroelectric Project***

Based on the encouraging results obtained during laboratory tests, the Electric Power Research Institute (EPRI) undertook a search for a suitable site to test a prototype Eicher Screen. In 1989, EPRI entered into an agreement to evaluate a full-scale installation of an Eicher Screen to be installed by James River II, Inc., in one of the 2.7-m (8.9-ft) diameter penstocks at the Elwha Hydroelectric Project (Elwha). The screen design was developed based on fish passage information gained during laboratory studies conducted by EPRI in 1984 and 1985 and a hydraulic model study conducted by James River II, Inc., in 1989 (EPRI 1991).



Two major refinements were made to the screen design during the hydraulic model studies. The design of the screen support structure was modified in order to reduce head loss and the porosity (percent open area) of the screen was reduced at the downstream end of the screen to provide a more uniform flow field over its entire length. Modifications to the screen support structure included removing two-thirds of the U-clips (provided to maintain even bar spacing), angling the U-clips and associated support bars into the direction of the flow, and removing excess material on the upstream side of the U-clips. These modifications were found to reduce head loss across the screen by more than 50%. During fabrication of the screen panels, "comb"-type spacers were installed mid-way between the remaining U-clips to maintain even spacing between the screen bars.

Using the refined design, the prototype was installed in one of the 2.7-m (9-ft) diameter penstocks at Elwha in the spring of 1990. The screen was installed as part of a 14.1-m (46.3-ft) long prefabricated penstock section. Screen panels of three different porosities were mounted on a steel frame designed to withstand the pressure differential that would result from a fully clogged condition. The inclined portion of the screen was comprised of two sections with uniform bar width (1.9 mm [0.1 in.]) but different bar spacing. The upstream section was 6.1 m (20 ft) in length and had a porosity of 63% with an opening between the bars of 3.2 mm (0.13 in.). The downstream screen section was 2.3 m (7.5 ft) in length and had a screen porosity of 32%, with an opening between the bars of 0.9 mm (0.04 in.). The section of screen in the bypass transition was 2.1 m (6.9 ft) in length and had a porosity of 8%, with a 2.4-mm (0.9-in.) bar width and a 0.2-mm (0.01-in.) opening between the bars. The entire screen, including the transition section, was mounted on a frame and pivot so that it could be cleaned by back flushing or put into a "neutral" position parallel to the penstock flow when not in use. The screen was protected from large debris by a trash rack with 5-cm (2-in.) spacing at the penstock intake.

Tests conducted in 1990 and 1991 demonstrated a passage survival (diversion efficiency adjusted for 96-hour survival) equal to or exceeding 98.7% for all three species of salmonid smolts tested (EPRI 1992a). Although the facility was not specifically designed to pass fish smaller than smolts, tests showed that passage survival averaged 99.2% for coho fingerling pre-smolts (average length: 102 mm [4 in.]), 99.9% for Chinook fingerling pre-smolts (average length: 73 mm [2.9 in.]), 97.1% for steelhead fry (average length: 52 mm [2 in.]), and 91.6% for coho fry (average length: 44 mm [1.7 in.]). Excluding tests conducted at penstock velocities of 2.1 m/sec (6.9 ft/sec) or higher, the passage survival of coho fry was 95.9%.

Injuries were generally rare in tests conducted at penstock velocities of 2.1 m/sec (6.9 ft/sec) or less. For all species and life stages tested except Chinook smolts, the proportion of fish with >16% scale loss on one side ("descaled" as defined in criteria used on the Columbia River) averaged less than 1% at velocities of 1.2 and 1.8 m/sec (3.9 and 5.9 ft/sec), less than 2% at 2.1 m/sec (6.9 ft/sec), and less than 6% at 2.3 m/sec (7.5 ft/sec). Descaling was most common on Chinook smolts, averaging 0.4% descaled at 1.2 m/sec (3.9 ft/sec), 2.8% at 1.8 m/sec (5.9 ft/sec), 6.7% at 2.1 m/sec (6.9 ft/sec), and 12.6% at 2.3 m/sec (7.5 ft/sec), respectively. Injury rates increased substantially when the screen was partially clogged with introduced debris. Debris accumulations that produced as little as one or two tenths of a foot of head loss resulted in a noticeable increase in injury, particularly at the higher penstock velocities. However, the screen was readily cleaned by rotating it approximately 8 degrees.

The injury and mortality rates observed at Elwha were generally comparable to those found at state-of-the-art screening facilities designed for much lower approach velocities (usually 0.1 to 0.15 m/sec [0.3 to 0.5 ft/sec]). Exceptions include somewhat higher scale loss for Chinook smolts (up to 12.6%) and increased mortality of coho fry (up to 11.1%) at the highest velocities tested (2.1 to 2.3 m/sec [6.9 to 7.5 ft/sec]). In contrast to the results obtained in tests at low velocity screening facilities, high diversion efficiencies were conclusively demonstrated at Elwha. The few fish that were not recovered were counted as non-diverted fish in the calculation of the passage survival rates. Non-recovery of test fish at other types of facilities frequently exceed 10 to 20%, with possible losses attributed to predation, loss of fish past screen seals, and delayed passage through the facility.

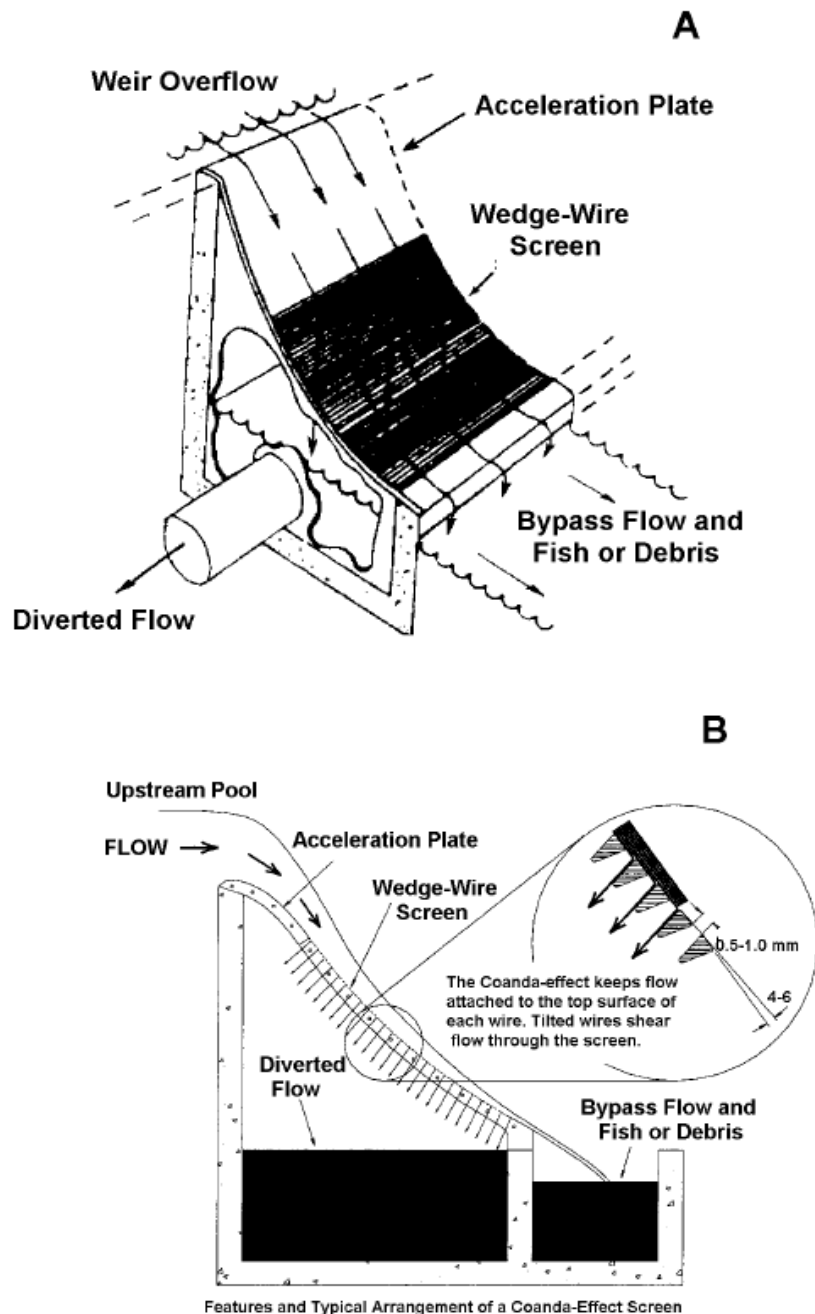
No operational problems were evident during testing, and head loss with a clean screen ranged from 0.15 m (0.5 ft) at 1.2 m/sec (3.9 ft/sec) to 0.58 m (1.9 ft) at 2.3 m/sec (7.5 ft/sec). Several possible design changes were identified for future applications, including: 1) use of a hydraulic operator to rotate the screen to increase the speed of screen cleaning and ensure more reliable seating of the screen, 2) possible changes to the porosity configuration to eliminate injury at the highest velocities, and 3) re-configuration of the bypass transition to enhance the velocity into the bypass at the downstream end of the screen.

## **Case Studies – Laboratory Studies**

### **Laboratory Study – Denver, CO**

A test was conducted at the Water Resources Research Laboratory in Denver, Colorado to evaluate the exclusion and survival efficiency of a high-velocity, inclined, profile-bar Coanda effect screen. Exclusion and survival rates of fathead minnow (*Pimephales promelas*) were assessed with different configurations of screens with 1.0- and 0.5-mm slot widths. The generalized body shape of the fathead minnow made it an ideal species for this application and allowed the test results to be generally applied to other species (Bestgen et al. 2004).

Inclined profile-bar screens consist of a flat or concaved surface, typically angled downward 46-60 degrees from horizontal (Figure 11-5). Water is delivered to the top of the screen via an overflow weir. Water continues onto an accelerator plate and across the screen face at a high velocity (2 to 3 m/sec [6.6 to 9.8 ft/sec]). Each individual bar is angled 5 degrees downstream, projecting the upstream edge of each bar slightly into the flow. A small proportion of the passing water is diverted through the screen. The high velocities limit screen exposure time for fish to 1 second or less, carrying them over the toe of the screen and into a bypass collection channel. These perpendicular screen velocities also aid in self-cleaning. In addition, the absence of moving parts minimizes the maintenance associated with operation. Unlike with traditional screen barriers, fish behavior, swimming performance, and approach and sweeping velocities are not considered in the design process or operation. Inclined profile-bar screens have a high filtration capacity, originating from the shearing effect caused by the bar tilt angle rather than from the screen porosity. Indications from other empirical and modeling data confirm this when comparing identical screens with different slot widths. It was shown that a change from 1.0-mm to 0.5-mm slot widths caused a reduction in screen porosity of 38%, but a reduction in filtration capacity of only 18% (Wahl 2001).



**Figure 11-5**  
**Main features and operation of a typical high-velocity inclined profile-bar screen (A). The section view (B) depicts the details of profile-bar position, arrangement, and function (Wahl 2001).**

Four screen and overflow configurations were tested with five different fish sizes (5.0, 7.5, 12.5, 22.5 and 45.0 mm [0.2, 0.3, 0.5, 0.9, and 1.8 in.]) (Bestgen et al. 2004). Fish were released at high and low positions in the water column (Table 11-2). The first configuration was with the screen inclined 45 degrees from horizontal with a 1.0-mm (0.04-in.) slot width set at a high (25%) overflow rate. For the second configuration, all factors remained the same except for a

decrease in the overflow rate to 10%. During the third configuration, the overflow rate and the slot width remained the same, but the angle was increased to 60 degrees from the horizontal. The fourth configuration was identical to the third with only the slot width decreased to 0.5 mm (0.02 in.). Control tests were also conducted to estimate mortality associated with handling, capture, and potential impingement on the toe of the screen.

**Table 11-2**

**Experimental design and number of replicates conducted for each screen type, overflow rate (high= 25%, low= 10%), experimental group (three control and two treatment groups), and nominal fish size-classes used to test survival and exclusion of fathead minnow by high-velocity inclined profile-bar screens (Bestgen et al. 2004).**

| Screen                 | Overflow rate | Experimental group   | Experimental replicates per nominal fish size-group (mm TL) |     |      |      |      |
|------------------------|---------------|----------------------|-------------------------------------------------------------|-----|------|------|------|
|                        |               |                      | 5.0                                                         | 7.5 | 12.5 | 22.5 | 45.0 |
| 45°; 1.0-mm slot width | High          | Background control   | --                                                          | 3   | 3    | --   | --   |
|                        |               | Net recovery control | --                                                          | 3   | 3    | --   | --   |
|                        |               | Screen control       | --                                                          | 5   | 5    | --   | --   |
|                        |               | High release         | 5                                                           | 5   | 5    | --   | --   |
|                        |               | Low release          | 5                                                           | 5   | 5    | --   | --   |
| 45°; 1.0-mm slot width | Low           | Background control   | --                                                          | 3   | 3    | --   | --   |
|                        |               | Net recovery control | --                                                          | 3   | 3    | 3    | 3    |
|                        |               | Screen control       | --                                                          | 5   | 5    | 5    | 5    |
|                        |               | High release         | 5                                                           | 5   | 5    | 5    | 5    |
|                        |               | Low release          | 5                                                           | 5   | 5    | --   | --   |
| 60°; 1.0-mm slot width | Low           | Background control   | --                                                          | 3   | 3    | --   | --   |
|                        |               | Net recovery control | --                                                          | 3   | 3    | --   | --   |
|                        |               | Screen control       | --                                                          | 5   | 5    | --   | --   |
|                        |               | High release         | 5                                                           | 5   | 4    | --   | --   |
|                        |               | Low release          | 5                                                           | 5   | 5    | --   | --   |
| 60°; 0.5-mm slot width | Low           | Background control   | --                                                          | 3   | --   | --   | --   |
|                        |               | Net recovery control | 3                                                           | 3   | 3    | --   | --   |
|                        |               | Screen control       | 5                                                           | 5   | 5    | --   | --   |
|                        |               | High release         | 10                                                          | 5   | 5    | --   | --   |
|                        |               | Low release          | 10                                                          | 5   | 5    | --   | --   |

To assess the difference in exclusion and survival rates of fish that approach the overflow weir at various depths, fish were released at either a high or low release point. High-released fish were introduced just above the water surface, while low-released fish were introduced through a 12.7-mm (0.1-in.) diameter plastic tube directly over the accelerator plate. Fish mortality was monitored daily for four days following testing. Survival rates were calculated by dividing the

number of screened fish that survived by the total number of excluded fish (entrained fish were not included). Abbott's formula was used in conjunction with screen control mortality data to adjust mortality rates of high and low releases.

**Abbott's formula:**  $p_c = (p_o - p)/(1 - p)$

Where  $p_c$ ,  $p_o$ , and  $p$  are the corrected, original, and screen control mortality proportions, respectively. Multifactor analysis of variance (ANOVA) was used to assess the differences in exclusion and survival rates among treatments. Least-squares means (LSM) were used to compare means of exclusion and survival data (Table 11-3).

**Table 11-3**  
**ANOVA results for models that assessed the effects of screen type, fish release position, and screen by release position interaction on exclusion and survival rates of various sizes of fathead minnow in tests of high-velocity, inclined, profile-bar screens (Bestgen et al. 2004).**

| Model                | Effect                    | df | Sum of Squares | F     | P       |
|----------------------|---------------------------|----|----------------|-------|---------|
| 12.5 mm TL; survival | screen                    | 2  | 0.82151        | 5.85  | 0.0089  |
|                      | release position          | 1  | 0.71078        | 10.12 | 0.0042  |
|                      | screen X release position | 2  | 0.75249        | 5.36  | 0.0123  |
| 7.5 mm TL; exclusion | screen                    | 2  | 1.76288        | 25.72 | <0.0001 |
|                      | release position          | 1  | 0.52799        | 15.40 | 0.0006  |
|                      | screen X release position | 2  | 0.77879        | 11.36 | 0.0003  |
| 7.5 mm TL; survival  | screen                    | 2  | 0.14131        | 0.91  | 0.4162  |
|                      | release position          | 1  | 2.25853        | 29.07 | <0.0001 |
|                      | screen X release position | 2  | 0.41200        | 2.65  | 0.0911  |
| 5.0 mm TL; exclusion | screen                    | 2  | 6.01255        | 68.40 | <0.0001 |
|                      | release position          | 1  | 2.50861        | 57.07 | <0.0001 |
|                      | screen X release position | 2  | 0.63383        | 7.21  | 0.0025  |

The survival rate of control and treatment fish increased with size. A similar trend was found with the exclusion and survival rates among all screen and treatment types (Table 11-4). Nearly 100% of 12.5-mm (0.5-in.) and larger fathead minnows were excluded, with survival rates  $\geq$  60%. High exclusion rates for this size group can be attributed to the 2.0-mm (0.08-in.) diameter of the fish, which is twice the size of the largest slot width tested. It can be generalized that fish larger than the size tested would also survive at high rates and be efficiently excluded by the screen. Exclusion rates for 5.0-mm (0-2 in.) fish exposed to screens with 1.0-mm (0.4-in.) slot width were low, ranging from 2–68%. However, for screens with a 0.5-mm (0.2-in.) slot width, the range was higher (0-100%). Exclusion of 5.0-mm (0.2-in.) fish (maximum diameter of these fish was 0.7 mm [0.03 in.]) was 68% for the 1.0-mm (0.04-in.) screen at the high release point. The lowest exclusion (12%) was observed with the 1.0-mm (0.04-in.) screen at the low release point, suggesting that encounters with screen slots larger than the fish's maximum diameter

increased entrainment. Rate of exclusion observed with 7.5-mm (0.3-in.) fish was 0 to 98% for all screen types and release points (Table 11-4).

**Table 11-4**

**Mean exclusion and survival rates (% SE and number of replicates in parentheses) of 12.5-, 7.5-, and 5.0-mm TL fathead minnow released over four different high-velocity inclined profile-bar screen configurations. Screen Control (SC) fish were released over the lower surface of the screen where the profile bars were covered by tape. High-release (HR) and Low-release (LR) fish entered the screen model at the surface and the bottom of the water column, respectively (Bestgen et al. 2004).**

| Fish Size (mm)  | Screen and Treatment type            |              |             |                                     |              |              |
|-----------------|--------------------------------------|--------------|-------------|-------------------------------------|--------------|--------------|
|                 | 45, 1.0-mm slot width, high overflow |              |             | 45, 1.0-mm slot width, low overflow |              |              |
|                 | SC                                   | HR           | LR          | SC                                  | HR           | LR           |
| Exclusion rates |                                      |              |             |                                     |              |              |
| 12.5            | 100                                  | 100          | 98 (2.5, 5) | 100                                 | 100          | 100          |
| 7.5             | 100                                  | 76 (2.3, 5)  | 16 (4.0, 5) | 98 (2.0, 5)                         | 90 (5.5, 5)  | 34 (9.1, 5)  |
| 5.0             |                                      | 48 (17.5, 5) | 2 (2.0, 5)  |                                     | 56 (6.8, 5)  | 2 (2.0, 5)   |
| Survival rates  |                                      |              |             |                                     |              |              |
| 12.5            | 56 (9.3, 5)                          | 36 (14.9, 5) | 4 (3.6, 5)  | 100                                 | 86 (9.3, 5)  | 62 (9.7, 5)  |
| 7.5             | 2 (2.0, 5)                           | 0            | 0           | 37 (8.6, 5)                         | 36 (10.1, 5) | 9 (9.1, 5)   |
| 5.0             |                                      |              |             |                                     |              |              |
| Fish Size (mm)  | 60, 1.0-mm slot width, low overflow  |              |             | 60, 0.5-mm slot width, low overflow |              |              |
|                 | SC                                   | HR           | LR          | SC                                  | HR           | LR           |
|                 | Exclusion rates                      |              |             |                                     |              |              |
| 12.5            | 100                                  | 98 (2.0, 5)  | 96 (2.5, 5) | 100                                 | 100          | 100          |
| 7.5             | 100                                  | 76 (2.5, 5)  | 68 (8.6, 5) | 100                                 | 98 (2.0, 5)  | 98 (2.0, 5)  |
| 5.0             |                                      | 68 (8.6, 5)  | 22 (8.6, 5) | 100                                 | 95 (2.7, 10) | 88 (2.5, 10) |
| Survival rates  |                                      |              |             |                                     |              |              |
| 12.5            | 100                                  | 62 (10.9, 4) | 71 (8.6, 5) | 80 (7.1, 5)                         | 66 (5.0, 5)  | 15 (4.7, 5)  |
| 7.5             | 52 (15.0, 5)                         | 26 (11.6, 5) | 4 (4.2, 5)  | 62 (8.1, 5)                         | 57 (3.3, 5)  | 0            |
| 5.0             |                                      |              |             | 56 (4.0, 5)                         | 28 (16.5, 5) | 0            |

Exclusion and survival rates of fish smaller than 12.5 mm (0.5 in.) were heavily dependent on release position and screen configuration. When released higher in the water column, these smaller fish were less likely to encounter the screen and therefore had higher exclusion rates than those released lower in the water column. Survival rates were much higher because fish

sustained less physical abrasion. Physical abrasion was the principal cause of mortality in the low-released fish that were dead. Low-released fish had the lowest survival, specifically in tests with the 0.5-mm (0.02-in.) screens. Narrower spacing per unit of screen length in the 0.5-mm (0.02 in.) screens effectively increased the frequency of screen contacts, thus adversely affecting the survival rate.

Exclusion and survival rates were not significantly affected by screen angle. However, exclusion rates were generally higher for the 60-degree screens than for the 45-degree screen. Conversely, survival rates were generally higher with the 45-degree screen than with the 60-degree screen. It was concluded that 0.5-mm (0.02-in) slot widths maximized the exclusion of 5.0- and 7.5-mm (0.2- and 0.5-in) fish. Slot width was the most significant factor affecting exclusion rate. Screen overflow rate had the greatest effect on survival and entrainment rates. Higher overflow rates could reduce the frequency of screen contact, and therefore reduce entrainment and mortality rates. While swimming ability typically plays an important role in the frequency of screen contact, fish pass too quickly over the high-velocity inclined profile bar screens for swimming ability to become a factor.

### **EPRI/Alden Laboratory Study**

The MIS was evaluated first in laboratory studies at Alden Research Laboratories, Inc. to determine: (1) the design configuration which yields the best hydraulic conditions for safe fish passage (1:6.6 scale hydraulic model), and (2) the biological effectiveness of the optimal design in diverting selected fish species to a bypass (1:3.3 scale biological test flume) (EPRI 1994b). Results from tests performed with the 1:6.6 model indicate that the MIS creates optimal hydraulic conditions for fish diversion. Biological tests were conducted in the 1:3.3 flume with juvenile walleye (*Sander vitreus*), bluegill (*Lepomis macrochirus*), channel catfish (*Ictalurus punctatus*), American shad (*Alosa sapidissima*), blueback herring (*Alosa aestivalis*), golden shiner (*Notemigonus crysoleucas*), rainbow trout (*Oncorhynchus mykiss*) (two size classes), brown trout (*Salmo trutta*), Chinook salmon (*Oncorhynchus tshawytscha*), coho salmon (*Oncorhynchus kisutch*), and Atlantic salmon (*Salmo salar*). Fish passage (diversion efficiency and latent mortality) was evaluated at water velocities ranging from 0.6 to 3.0 m/sec (2 to 9.8 ft/sec).

The range of mean lengths for all species tested was between 47 and 88 mm (1.9 and 3.5 in.), with the exception of Atlantic salmon, which averaged 169 mm (6.7 in.) in length. Diversion rates reached 98% or greater at water velocities up to 2.4 m/sec (7.9 ft/sec) for walleye and 1.83 m/sec (6 ft/sec) for bluegill. Diversion efficiencies of channel catfish, golden shiner, and brown trout exceeded 98% at all water velocities that were tested, including 3.0 m/sec (9.8 ft/sec). The diversion efficiency of rainbow trout fry and juveniles exceeded 99% at velocities up to 1.8 and 2.4 m/sec (5.9 and 7.9 ft/sec). Diversion rates exceeded 99% at all velocities for tests with coho salmon and at all velocities up to 2.4 m/sec (7.9 ft/sec) for tests with Chinook salmon. Atlantic salmon smolts demonstrated 100% diversion at all velocities tested, including 3.0 m/sec (9.8 ft/sec). Diversion efficiencies for American shad and blueback herring were lower and latent mortality was higher than observed for the other species. However, latent mortality was comparable between control and test fish of these species indicating that stress from capture, handling, and testing probably contributed to the lower diversion rates. Generally, latent mortality of test fish that was adjusted for control mortality was low (0 to 5%) for all other species evaluated.

### ***Hydraulic Model Study – Alden***

In order to assess the potential for improving the flow distribution of the Eicher Screen at Elwha, EPRI conducted a hydraulic model study in 1992 at Alden Research Laboratory (Alden). A 1:4.5 scale model of the Elwha Eicher Screen was constructed and several modifications to the screen's porosity configuration were evaluated (Winchell et al. 1993). These tests showed that using a more gradual transition in screen porosity in the downstream end of the screen resulted in a slightly more uniform flow distribution than the original configuration, reducing the maximum velocity normal to the screen by about 10%. In addition, the flow field upstream of the screen was measured to determine whether the hydraulic conditions at the Elwha Eicher Screen were affected by a 16-degree bend in the penstock located 4.6 m (15 ft) upstream of the screen. These measurements showed that the bend had no significant effect on the flow distribution measured at the upstream end of the screen. Further studies were conducted to evaluate a modified bypass design for the Eicher Screen that should simplify construction and improve hydraulic conditions for diverting and bypassing fish.

### ***EPRI/University of Washington Laboratory Study***

EPRI funded a laboratory study in 1984–85 that evaluated passage success of an Eicher Screen with rainbow trout and smolts of coho salmon, Chinook salmon, and steelhead trout at the Harris Hydraulics Laboratory, University of Washington (EPRI 1987, Wert 1988). A Plexiglas flume was constructed with a test section 2.4 by 0.15 m (7.9 by 0.5 ft), which was used primarily to evaluate the effect of bypass and channel water velocities on fish passage success. The effects of lighting, various screen types, and screen angle were examined to a lesser extent. The screen was found to be effective at diverting fish under a range of hydraulic conditions with little or no injury. Flume velocities ranging from 0.82 to 2.7 m/sec (2.7 to 8.9 ft/sec) were evaluated. Fish were most vulnerable to impingement in the area just upstream of the bypass entrance. Impingement occurred primarily when the water velocity approaching the bypass was less than the average velocity in the flume. The laboratory study also indicated that impingement was less likely under high flume velocities (over 1.5 m/sec [4.9 ft/sec]). Wedgewire screening material from two suppliers was tested. Both Hendrick and Johnson wedgewire type screens (with bars of 2 mm [0.08 in.] width and opening between bars of 2 mm [0.08 in.]) performed satisfactorily with respect to fish and debris passage. Impingement was reduced when the opening between bars was reduced from 2 to 1 mm (0.08 to 0.04 in.) in the downstream-most 0.45 m (1.5 ft) of the screen.

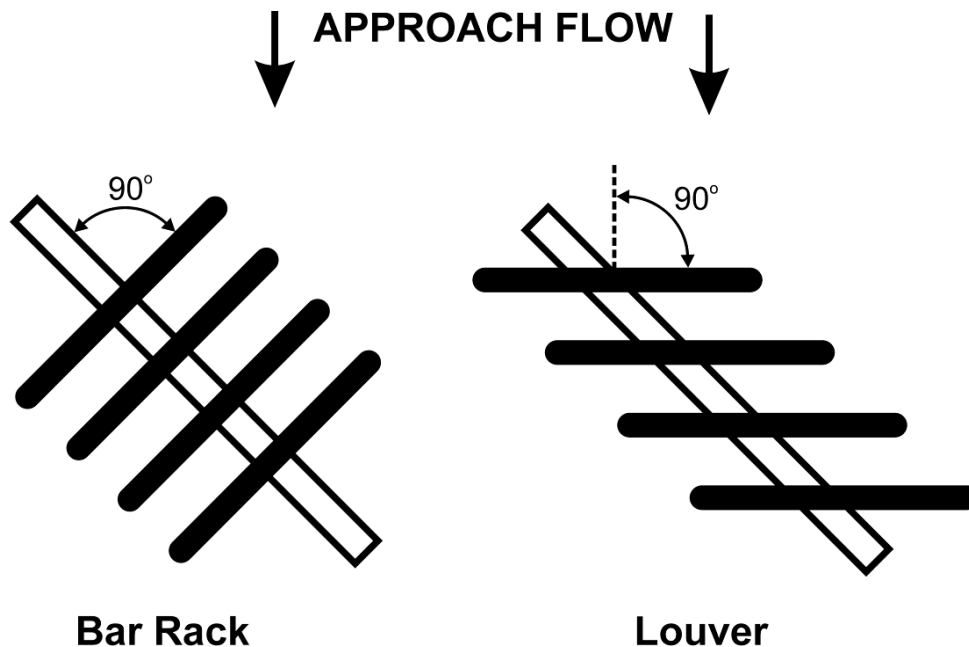


# 12

## ANGLED BAR RACKS AND LOUVERS

### Introduction

Angled bar racks and louvers consist of an array of evenly spaced vertical slats aligned across a channel at a specified angle and leading to a bypass. Louver slats are oriented 90 degrees to the flow while angled rack slats are angled 90 degrees to the rack frame and their orientation to the flow will be dependent upon the angle of the entire rack structure (Figure 12-1). Results of angled bar rack and louver studies to date have been variable by species and site. However, numerous studies have demonstrated that diversion efficiency of louvers can be on the order of 80 to 95% for a wide array of species and design and operational conditions (EPRI 1986b, 1994a, 2000; 2001).



**Figure 12-1**

**Orientation of angled bar racks and louvers slats. The structures depicted are angled at 45 degrees to the approach flow (EPRI 2001).**

Though typically classified as a diversion technology, the mode of action in the guidance of fish along these structures is believed to be behaviorally based. Using their lateral line sensory system, fish guiding along angled bar racks and louvers detect flow disturbances (turbulence) created by the slats and actively avoid the structure while moving downstream with the flow towards a bypass.

Louver systems have been used at one cooling water intake structure (CWIS) and have been applied successfully at several hydroelectric and irrigation facilities in the Northwest and Northeast. Laboratory studies that led to this application showed high diversion efficiencies for the Pacific marine species of importance at this CWIS (Schuler 1973). Other laboratory studies conducted for potential CWIS application on the East Coast showed reasonably high diversion efficiencies with striped bass (*Morone saxatilis*), white perch (*Morone americana*), and Atlantic tomcod (*Microgadus tomcod*) (Taft and Mussalli 1978). Studies of louver facilities at hydroelectric and irrigation facilities on both coasts have shown that salmonid and clupeid species were successfully diverted to bypasses. In all studies, louver effectiveness has been shown to be species-, life stage-, and site-specific and depends extensively on the swimming capabilities and behavior of target species, the angle and orientation of the louver array, approach and bypass velocities, and localized hydraulic conditions. While louvers may be considered for potential CWIS application, given the limited data available for such application to date, further studies with species of importance at CWISs are needed to define the full potential of this technology.

## **Case Studies – Hydroelectric and Water Diversion Applications**

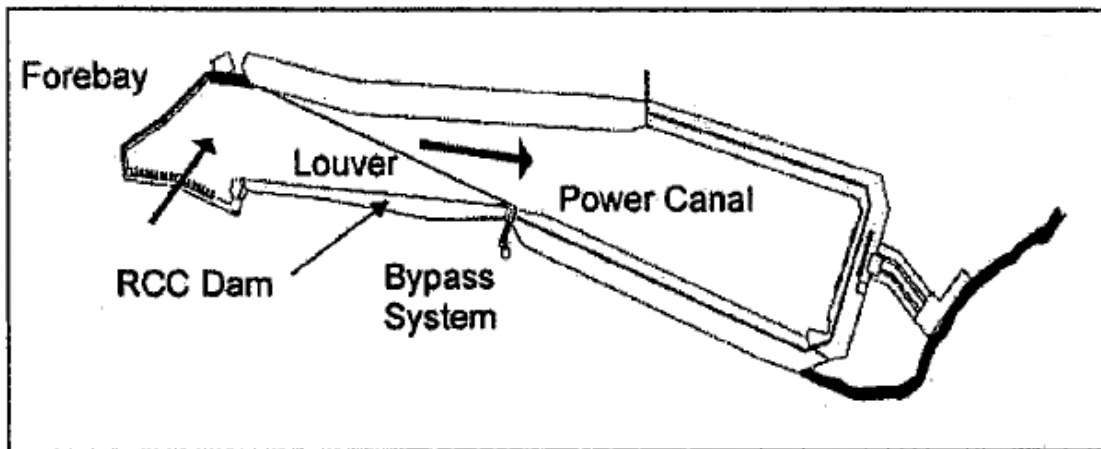
### ***Grand Falls – Windsor Hydroelectric Project***

Scruton et al. 2003 conducted a 5-year evaluation (1997–2001) of a louver system located in the power canal of the Grand Falls generating facility on the Exploits River in Newfoundland (Scruton et al. 2003). The power canal is 40 to 60 m (131.2 to 196.9 ft) wide, 450 m (1,476.4 ft) long, and 6.0 m (19.7 ft) deep and has an average velocity of 0.7 to 0.8 m/sec (2.3 to 2.6 ft/sec) (Figure 12-2). Water from the canal enters five Francis turbines through two submerged intake gates at an average rate of 183 m<sup>3</sup>/sec (6,462.6 cfs) ranging between 160 to 210 m<sup>3</sup>/sec (56,503 to 7,416.1 cfs). The louver bypass system consists of a series of floating sections measuring 2.4 m (7.9 ft) long, with two louvers panels on each. Each panel extends to a depth of 2 m (6.6 ft). The high density polyvinyl chloride slats measure 160 mm (6.3 in.) wide, 10 mm (0.4 in.) thick, and extend to a depth of 2 m (6.6 ft). The slats are set at 72 degrees to the frame and are spaced 10 cm (3.9 in.) apart. The whole louver array measures 187 m (163.5 ft) in total length when set at 18 degrees to the canal wall. The bypass at the downstream end of the louver array has a 1.0 m (3.3 ft) wide and 1.5 m (4.9 ft) deep entrance. The entire bypass system extends 26.5 m (86.9 ft) to its outfall, which is approximately 18 m (59.1 ft) above the plunge pool. Along its length, there is a 2.5 m (8.2 ft) long counting table to which Atlantic salmon (*Salmo salar*) smolts can be diverted by a 12.6 m (41.3 ft) long wedgewire screen for counting and examination.

The monitoring of the effectiveness of the louver bypass system had four original objectives: 1) to assess the fish guidance efficiency (FGE) of the system for Atlantic salmon smolts, 2) to assess the residency time of fish in the canal, 3) to assess fish condition, 4) and to monitor the hydraulic conditions of the canal, louver array, and bypass. This 5-year evaluation, however, focused mainly on FGEs and hydraulic conditions.

Trials began in 1997 with releases of passive integrated transponder (PIT) tagged and radio-tagged smolts. The movement and behavior of tagged fish was documented through the use of both fixed and hand held receivers. FGE (from the PIT-tagged smolts) over the 3 weeks of testing averaged 33.4% for nighttime releases and 9.1% for daytime releases. Radio-tagged fish held mainly near the surface indicating that smolts that were not diverted by the louvers likely

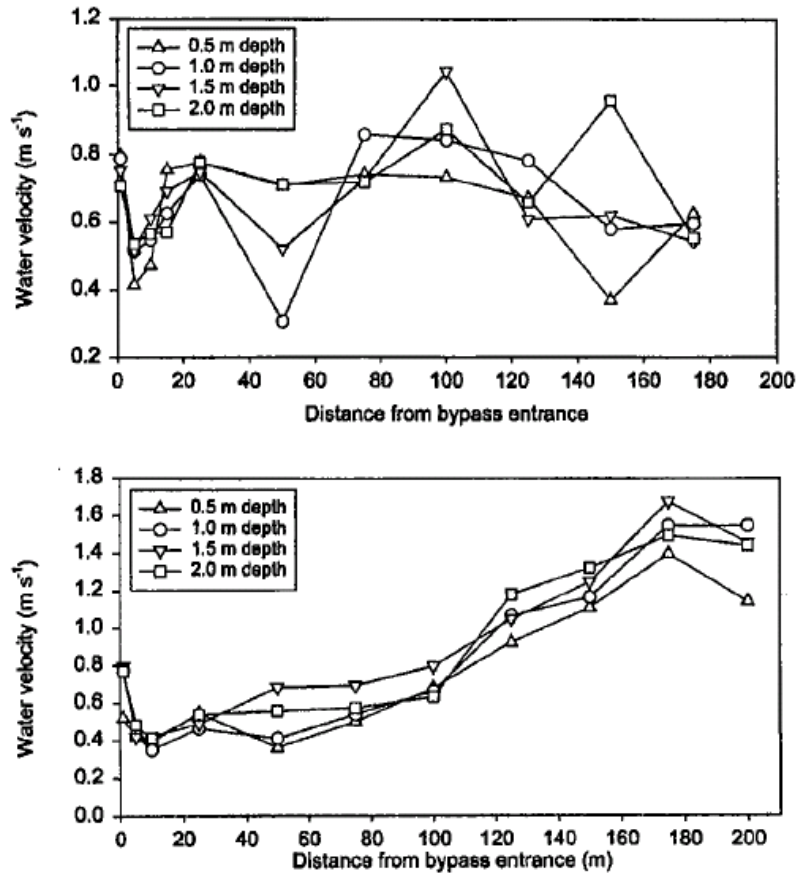
passed through the louver slats and beneath them. Low FGEs were attributed to suboptimal hydraulic conditions related to the design and operation of the louver facility.



**Figure 12-2**  
**Schematic diagram of the Grand Falls Power Canal, showing louver line, bypass, and dam**  
(Scruton et al. 2003)

Trials in 1998 consisted of 14 releases of radio-tagged smolts and two releases of streamer-tagged smolts. Tracking of these was done manually, with fixed antennae, and with the use of digital spectrum processors (DSP). A total of 14 antennae were spaced 18 m (59.1 ft) apart along the louver array giving full coverage of the entire louver array as well as the entrance to the bypass. The DSP system logged all detections, antennae positions, and signal strengths. Trials were run with the louver array set at 18 degrees and at 12 degrees (two trials). Velocities were measured at 0.5, 1.0, 1.5, and 2.0 m (1.6, 3.3, 4.9, and 6.6 ft) deep along the louver array. Trials conducted with the louver array at 12 degrees yielded an average FGE of 24.3%, which was comparable to the 1997 results with the louver array at 18 degrees. The DSP telemetry system proved extremely useful during the 1998 evaluations and indicated that smolts not successfully bypassed went through as opposed to under array.

Water velocity measurements along the louver array appeared to be suboptimal and likely led to the poor guidance efficiencies observed in 1997 and 1998 with the array at 18 degrees. With the change in angle of the array in 1998 to 12 degrees, velocities showed much less variability (Figure 12-3) but still had poor guidance characteristics (i.e., velocities decreasing along length of louver array with bypass entrance velocities well below design criteria).



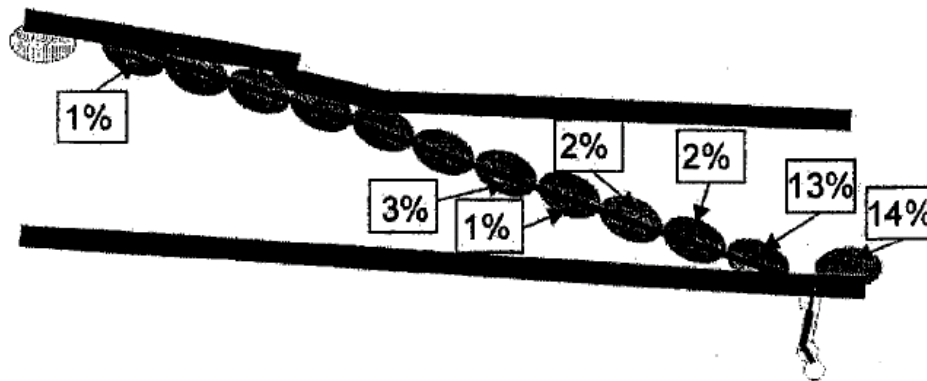
**Figure 12-3**  
**Water velocity profiles along the louver array at depths of 0.5, 1.0, 1.5, and 2.0m in 1998.**  
**Upper panel is for a louver angle of 18 degrees, after modifications to the bypass entrance.**  
**Lower panel is for a louver angle of 12 degrees (Scruton et al. 2003).**

In 1999, a hydraulic study was conducted in the hydraulics laboratory of the University of Waterloo in Ontario, Canada, using a 1:25 scaled model to identify hydraulic problems within the power canal and louver bypass system. This lab study helped identify needed modifications before the next field evaluation. The studies confirmed the existence of poor guidance conditions near the center of the array and at the bypass entrance, as well as the existence of reverse flow conditions and large vortex eddies. The laboratory study identified the old penstock bulkhead as a major source of flow perturbation. In addition to the removal of this abutment, the louver array was found to function more efficiently at 12 degrees instead of at 18 degrees. The laboratory study led to further modifications including: the addition of a vertical guide wall at the bypass entrance, ramping flows into the bypass entrance, installing a half pipe at the bypass entrance, and increasing the bleed-off capacity in the bypass.

After these modifications to the bypass system, field evaluations continued in 1999 with radio-tagged smolts. Poor guidance conditions were again identified near the center of the louver array, but data collected with the DSPs revealed more effective guidance along the louver compared to previous years. FGEs increased to an average of about 54% with an associated decrease in the loss of smolts in the vicinity of the bypass entrance (from 20% in 1998 to 3% in 1999).

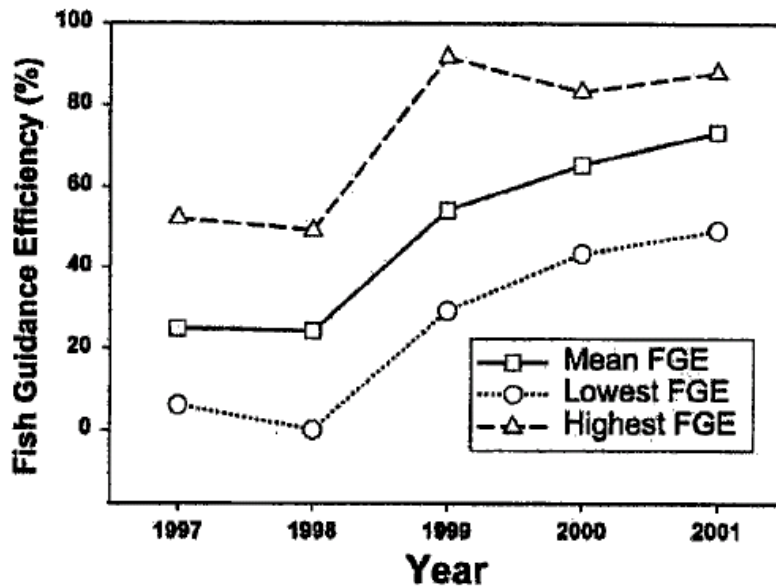
Prior to continued field evaluations in 2000, the concrete abutment separating the forebay from the power canal was removed based on the results of the laboratory studies conducted in 1999. Additionally, the louver array was returned to an angle of 18 degrees. Tagging studies then proceeded with the release of 668 streamer-tagged smolts and 200 radio-tagged smolts. Results of the velocity monitoring showed that the poor guidance conditions at the bypass entrance still existed (confirmed by the smolt loss data recorded by the DSP telemetry system [Figure 12-4]). The DSP telemetry showed improved guidance along the louver from that of previous years. The overall FGE averaged increased to 65.3% from the 54.0% observed in 1999. However, an increase in smolt loss (from 3% in 1999 to 14% in 2000) was noted at the bypass entrance.

Trials in 2001 consisted solely of radio-tagged smolts (24 trials, 2,180 smolts total). The goals of the releases in 2001 were to monitor FGE and canal hydraulics, conduct a count of smolt migration, and to document the level of entrainment of river fish into the power canal. Other than a slight improvement of the flow variability near the center of the array, guidance conditions remained similar to 2000. The average FGE was slightly higher (73.3%) than 2000.



**Figure 12-4**  
Schematic diagram of the louver line and bypass facility indicating detection cells (shaded circles) of 13 underwater antennae of the DSP telemetry system, as deployed in 2000. The Proportional losses of smolts at seven detection cells, as percentage of all fish released from all trials (percentage values in boxes), is indicated (Scruton et al. 2003).

Overall, there was an improvement of the hydraulic characteristics and FGE of the louver array at the Grand Falls project. Low mean FGEs in 1997 and 1998 were improved during each following years of study (Figure 12-5). The data collected during field evaluations and the hydraulic laboratory study were successful in defining the needed modifications to the louver and bypass system.



**Figure 12-5**  
 Fish guidance efficiencies (unadjusted) for Atlantic salmon smolts for the 5 years of monitoring, 1997 to 2001 (Scruton et al. 2003)

### ***T. W. Sullivan Hydroelectric Project***

Cramer (1997) provides an update of the effectiveness of the louvers that have been in operation at the T.W. Sullivan Project on Willamette River, Oregon, since 1992. The flow enters the forebay at 90 degrees, which enabled the plant to use the existing trash racks as the louver system. All sharp angles were eliminated and a training wall was added. The forebay has a depth of 6.7 m (22 ft). The last unit opening serves at the louver bypass. Bypassed fish are diverted to a bypass and return pipe via the Eicher screen. The system incorporates an evaluator that has been modified in a number of ways over time to reduce injury to fish. As currently operated, the louver system is estimated to be 92, 82, and 85% effective in diverting spring Chinook (*Oncorhynchus tshawytscha*), fall Chinook, and steelhead (*Oncorhynchus mykiss*), respectively. Examination of over 500,000 fish between 1991 and 1995 showed an average occurrence of injury and descaling of 0.44 and 1.81%, respectively (Cramer 1997).

### ***Vernon Hydroelectric Station***

In 1994, New England Power Company completed the installation of a louver guidance and bypass system for outmigrant juvenile clupeids (*Clupeidae*) and Atlantic salmon (*Salmo salar*) smolts at the Vernon Hydroelectric Project on the Connecticut River (Normandeau Associates 1996a). The station operates run-of-the-river and has a nominal generating capacity of 27 MW. The louver system is 47.5 m (155.8 ft) long and contains eleven 3.7 m (12.1 ft) wide by 3.0 m (9.8 ft) high removable louver panels. Each louver slat is made of stainless steel and measures 5 cm (2.0 in.) wide, 9.5 mm (0.4 in.) thick, and 3.0 m (9.8 ft) long. The slats are angled at 60 degrees to the structure and are spaced 7.6 cm (3 in.) apart. The louver system is installed in the inner forebay and is designed to intercept fish following prevailing flows created by operation of Units 9 and 10 and guide them to the bypass (called the “fish pipe”). The fish pipe is 25.1 m

(82.3 ft) in length and 1.2 m (3.9 ft) high throughout its length, and its width tapers from 2.3 m (7.5 ft) at the entrance to 0.80 m (2.6 ft) at the discharge to the tailrace. The fish pipe discharges 9.9 m<sup>3</sup>/sec (349.6 ft<sup>3</sup>/sec) at normal pond elevations.

A second fish passage facility was also installed in 1994 and is referred to as the “fish tube.” The fish tube makes use of an existing pipe that supplied attraction flow to the project’s fish ladder. A surface-fed entrance was constructed in order to attract and pass fish. The entrance is 2.4 m (7.9 ft) high by approximately 0.9 m (3.0 ft) wide. The passage pipe tapers from 1.2 m (3.9 ft) in diameter at the upstream end to 0.6 m (2 ft) in diameter, where it discharges into the tailrace below the powerhouse.

The behavior and movement of hatchery-reared Atlantic salmon smolts was monitored near Vernon to determine the guidance efficiency of the louver system, to monitor use of the fish tube, and to track passage through the turbines and down the fish ladder. Radio-tagged smolts were released in six groups upstream of the dam. A total of 173 (of 185 released) radio-tagged smolts were monitored as they passed via various possible routes.

Forty-one smolts (23.7%) passed via the louver fish pipe bypass, 68 smolts (39.3%) passed through the fish tube, and 60 (34.7%) passed through the turbines. Four fish (2.3%) had passage routes that were undetermined. The louver system was successful in excluding 42.1% of the smolts from the western forebay. However, most smolts resided in the eastern forebay for an average of 12 hrs before passing through the fish pipe. The authors suggested that the hesitation in passage was probably due to avoidance of the fish pipe entrance trash rack, which was periodically clogged with debris and altered attraction flows even when not clogged.

A separate evaluation of injury and survival was conducted on smolts passing via the fish tube (Normandeau Associates 1996a). Survival estimates for the test group were based on measures of injury and survival relative to a set of control group specimens. Seventy-five treatment specimens were passed through the fish tube and then recovered by netting the tailrace. They were then examined for injuries and held for 48 hrs for observation. Of the 75 test smolts, 70 (93.3%) were alive after 1 hr of capture. All of these fish survived the 48-hr holding period, thus the long term survival estimate was also 93.3%. Only 2 of the 70 (2.9%) smolts in the test group exhibited injuries. These injuries were scale losses of 10 and 20%.

### ***Tracy Fish Collection Facility***

A series of fish diversion studies have been conducted at the Tracy Fish Collection Facility (TFCF), which has a louver guidance system and is located on the San Joaquin River in California (Karp et al. 1995; Bowen et al. 1998). The TFCF collects fish from water that is diverted into the Delta Mendota Canal by the Tracy Pumping Plant. Passage studies conducted to date have evaluated the effectiveness of the TFCF, which comprises a louver-bypass-collection system that originally was installed in the 1950s. There are two louver arrays at the TFCF, a primary system and a secondary system. The primary louvers are 97.5 m (319.9 ft) in length and are oriented at a 15 degree angle to the flow. Four bypass openings are located at 22.9 m (75.1 ft) intervals along the array. Bypassed fish are diverted through 91.4 cm (36 in.) diameter pipes to the secondary louver system. The secondary louver array consists of two parallel panels that are 9.3 m (30.5 ft) long placed at a 15 degree angle to the flow. Fish diverted by the secondary system are passed through a common bypass pipe to holding tanks, where they are collected and returned to the river. All louver panels consist of vertical slats with 2.3 cm (0.9

in.) spacing. A surface trash deflector and trash racks with 5.3 cm (2.1 in.) bar spacing are located upstream of the louver system and are designed to collect large debris and prevent large fish from entering the system. The louvers are intended primarily to divert and collect juvenile Chinook salmon (*Oncorhynchus tshawytscha*) and striped bass (*Morone saxatilis*) greater than 25 mm (1 in.) in length.

In 1993, mark-recapture studies were conducted to evaluate the efficiency of the TFCF in diverting juvenile Chinook salmon and striped bass (Karp et al. 1995). Louver efficiency was estimated by releasing marked fish at several locations within the system (e.g., upstream of each louver array) and determining the proportion of fish re-captured in the bypass holding tanks. Twelve groups of striped bass and Chinook salmon were released at six different locations. Releases were conducted at several different flow, tide, and day/night conditions. The estimated louver diversion efficiencies were variable and differed between the primary and secondary systems. The diversion efficiency of the secondary louvers typically was higher than for the primary system and, for all conditions evaluated, ranged from 72 to 100% for Chinook salmon and 30 to 90% for striped bass. Primary louver efficiency ranged from 13 to 82% for Chinook salmon and 0 to 96% for striped bass. The lowest diversion efficiencies that were observed occurred with Chinook salmon during low flow/low velocity conditions (striped bass were not tested under these conditions) and with both species during periods when the louvers were clogged with debris or raised for cleaning. The highest diversion rates for Chinook salmon occurred in a test with moderately high flows and velocities during an incoming tide. The lower efficiency rates experienced during low flow/low velocity periods may have resulted, in part, from released fish moving upstream away from the collection facilities.

Bowen et al. (1998) describes studies conducted from 1993 through 1995 that evaluated fish collection and secondary louver efficiency at the TFCF. During these studies, the populations of fish collected in the bypass holding tanks and passing through the secondary louvers were characterized and diversion efficiency under a range of hydraulic and debris conditions was examined for key fish species (green and white sturgeon [*Acipenser medirostris* and *Acipenser transmontanus*], American shad [*Alosa sapidissima*], splittail [*Pogonichthys macrolepidotus*], white catfish [*Ameiurus catus*], delta smelt [*Hypomesus transpacificus*], Chinook salmon, and striped bass). The method used for these studies involved simultaneous sampling of the entire flow downstream of the louvers and the flow diverted to the bypass holding tanks. A sieve net was used to collect fish downstream of the louvers. A total of 254 paired samples were taken from the two locations. All fish recovered from the holding tanks and the sieve net were identified to the species and, when possible, measured for length. Secondary louver efficiency, referred to as salvage efficiency in the study report, was estimated by dividing the number of fish collected in the holding tanks by the total number of fish collected from both locations (i.e., holding tanks and sieve net). The effects of debris, time of day, and channel velocity on louver efficiency were evaluated using analysis of variance (ANOVA) statistical methods.

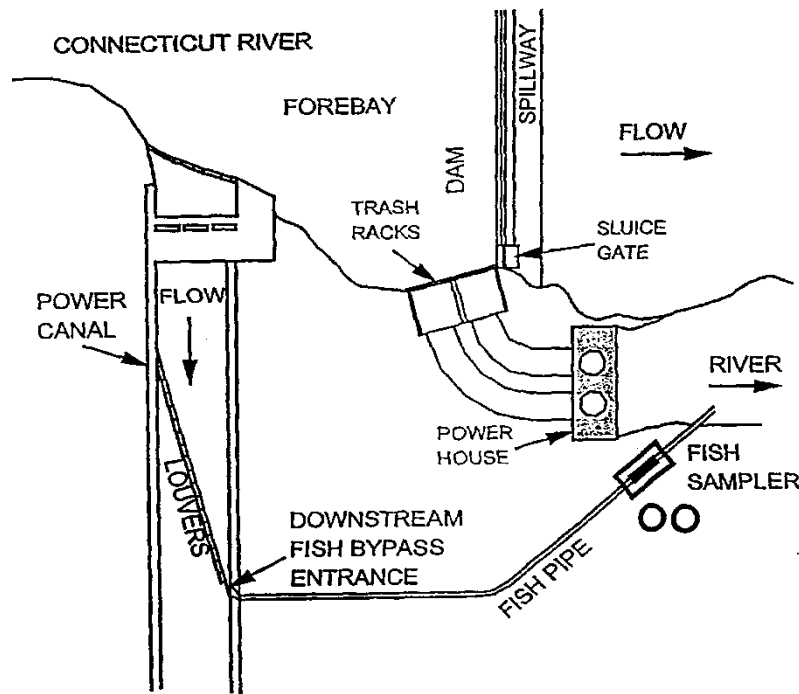
During the paired sampling, a total of 11,065 fish (28 species) was collected in the sieve net and 21,408 fish (33 species) were collected in the holding tanks. Splittail comprised over 50% of the fish collected from both locations and collection rates for all species combined were higher during daytime hours than during nighttime hours. For target species collected in adequate numbers (only two delta smelt and no green or white sturgeon were collected), the estimated mean efficiency of the secondary louvers ranged from 62.6 (splittail) to 88.7% (white catfish). Analysis of time of day, debris, and channel velocity effects revealed only two significant



relationships: a positive relationship between louver efficiency and time of day for all species and a negative relationship between efficiency and time of day for American shad. However, the analysis of these factors on louver efficiency was determined to be inconclusive due to limitations in the statistical model used, variability in louver efficiency estimates, and gaps in operational data that were collected (Bowen et al. 1998).

### **Holyoke Canal – Hadley Falls Hydroelectric Project**

Northeast Utilities Service Company conducted a major research effort evaluating the use of louvers for diverting juvenile and adult clupeids and Atlantic salmon smolts in the Holyoke Canal (part of the Holyoke Hydroelectric Project; Figure 12-6 and Figure 12-7) on the Connecticut River (Harza and RMC 1992; Harza and RMC 1993; Stira and Robinson 1997). An evaluation of louver effectiveness was performed with juvenile clupeids (American shad [*Alosa sapidissima*] and blueback herring [*Alosa aestivalis*]) at various canal flows. The study found that 76% of marked and recaptured test fish were guided, and 86% of naturally migrating fish were guided to a bypass that returned fish to the mainstem river (Harza and RMC 1993). A separate evaluation performed with Atlantic salmon (*Salmo salar*) smolts indicated an overall guidance effectiveness of between 85 and 90% (Harza and RMC 1992).



**Figure 12-6**  
Holyoke louver system (Stira and Robinson 1997)

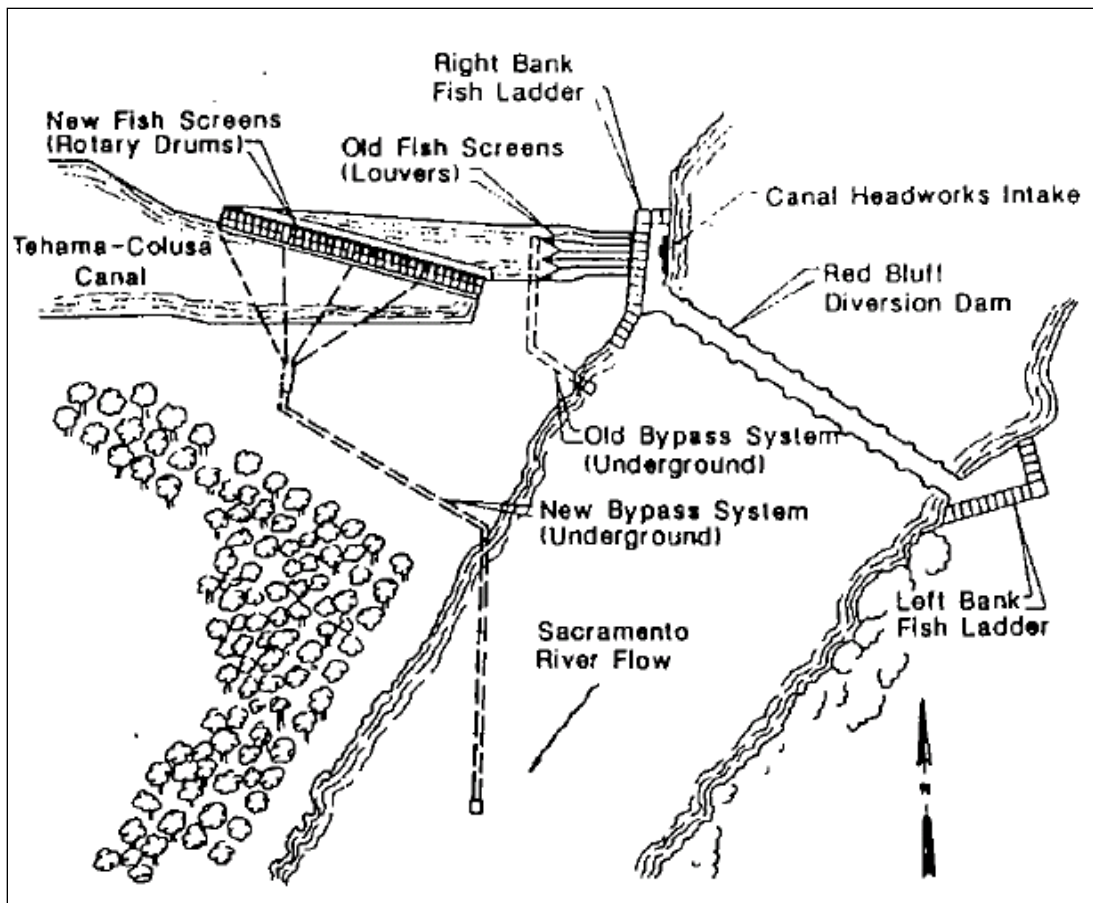


**Figure 12-7**  
**Holyoke louver system (photo courtesy of Alden)**

### ***Red Bluff Diversion Dam***

An evaluation of both the upstream and downstream passage facilities at the Red Bluff Diversion Dam (RBDD) was conducted from 1982 to 1987. The RBDD lies on the Sacramento River 243 river miles north of San Francisco Bay and was constructed to provide water to the Tehama-Colusa irrigation canal. The dam is comprised of 11 overflow weirs, each measuring 18.3 m (60 ft) wide. The discharge over the dam is controlled by wheel gates. Typical river flows are approximately 85.0 to 113.3 m<sup>3</sup>/sec (3,000 to 4,000 cfs).

The louver screen array and associated fish bypass system were installed during the original dam construction (Figure 12-8). The louver slats had a clear spacing of 3 cm (1.2 in.) and the array was set at 15 degrees to the flow. Fish were guided to one of five bypass entrances that led to 75 -cm (29.5-in.) diameter return pipes that returned outmigrant fish to the river downstream of the dam.



**Figure 12-8**  
**Red Bluff Diversion Dam and associated fish passage facilities (Vogel et al. 1990)**

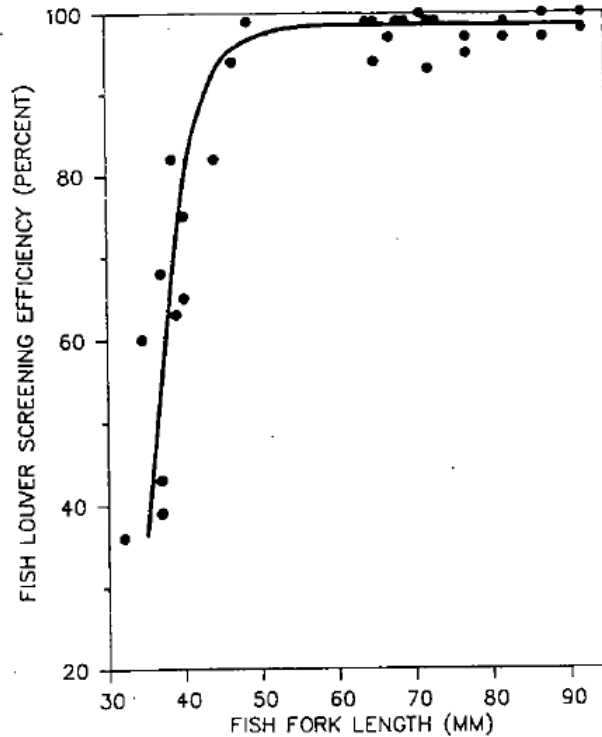
This evaluation of the louver array and bypass system at RBDD addressed four types of mortality possible to fish passing through the system:

1. Direct injury from passage below the dam gates or through the bypass facility,
2. Delay of downstream migration leading to abnormal smoltification and disruption of synchronization to seasonal temperatures and food production in the river and ocean,
3. Entrainment through the louver array and into the irrigation canal,
4. Increased predation in the impoundment and tailrace.

Thirty-three releases or marked juvenile Chinook salmon (*Oncorhynchus tshawytscha*) and steelhead trout (*Oncorhynchus mykiss*) were conducted to quantify injury and survival associated with downstream passage through the spill gates. When compared to controls, mortality of fish passing via the spill gates was at or near 0%. Thirty-four releases were conducted to discern the effects of passage through the louver bypass system and the results yielded a mortality of only 4%, though debris blockage of the return pipes leading to the tailrace may have had a negative effect on fish survival.

Tracking of 192 radio-tagged juvenile steelhead and Chinook salmon revealed that the delay in downstream migration in the impoundment was minimal. In addition to the radio tracking,

hatchery reared Chinook salmon were released 48.3 km (30 mi) upstream, passing into the tailrace in a few hours. Entrainment of juvenile Chinook salmon through the louver bypass system was monitored from January 1982 through November 1987. The number entrained yearly was approximately 333,333 within a range of 180,000 to 618,000 fish. Entrainment rates were highest at night. The screening efficiency of the louver system was about 98% for fish between 50 and 60 mm (2.0 and 2.4 in.), but less than 40% for the smallest fish (30 to 40 mm [1.2 to 1.6 in.]) (Figure 12-9). Estimates of overall mortality for emigrating salmon reached a high of 55% for fish released during the daytime and 16% for those released at night.



**Figure 12-9**  
**Louver screening efficiency for young Chinook salmon released into the Tehama-Colusa Canal Headworks (Vogel et al. 1990)**

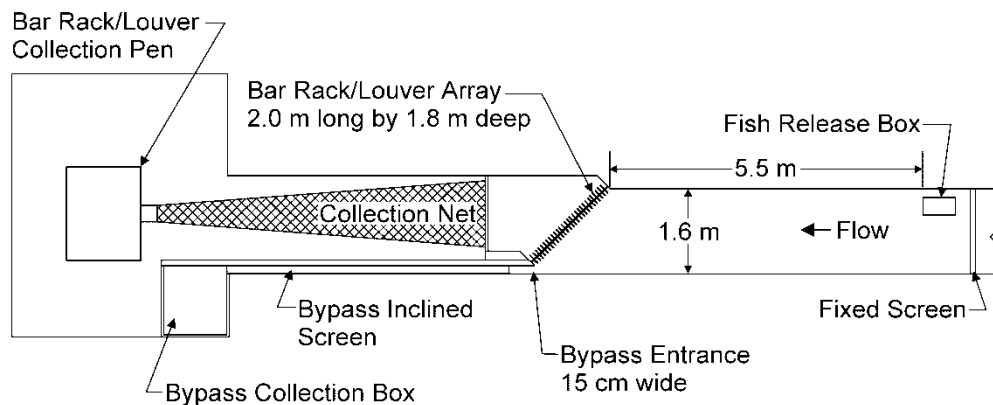
Though not measured directly, it is postulated that predation (principally by Sacramento pikeminnow [*Ptychocheilus grandis*]) had a significant effect on the survival of downstream migrant smolts. Downstream migrants also appeared to be disoriented by high velocities (6.1 to 9.1 m/sec [20 to 30 ft/sec]) and excessive air entrainment and turbulence associated with passage under the spill gates as well as through the louver system. Solutions offered to decrease predation included turning off the dam lights to decrease squawfish feeding efficiency, creating a commercial fishery to control squawfish populations, and developing a squawfish dispersal mechanism.

Due to inadequate performance, the louver array at the Red Bluff Diversion Dam was removed and replaced with an angled rotary drum screen.

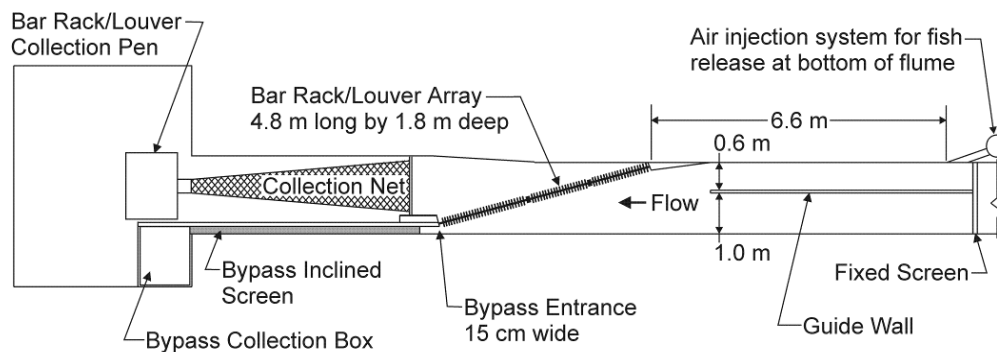
## Case Studies – Laboratory Evaluations

### EPRI

A laboratory study took place during 1999 and 2000 at Alden Research Laboratory to evaluate the ability of eight fish species to guide along various configurations of louvers and angled bar racks (EPRI 2001; Amaral et al. 2002a). The laboratory test facility was a 24.4 by 1.8 by 2.1 m flume (79 ft by 6 ft by 7 ft). The bar rack and louver arrays were angled 45 degrees to the flow in 1999 (Figure 12-10) and 15 degrees to the flow in 2000 (Figure 12-11). The major components of the test facility included an upstream fixed isolation screen, a fish release box, the bar rack/louver array, a collection net and pen downstream of the bar rack/louver, and a bypass with an inclined screen leading to a collection box. A bow thruster and motor were used to recirculate water through the closed loop system at the desired velocities. The flow rate in the flume ranged from about 0.8 m<sup>3</sup>/sec (28.3 cfs) at an approach velocity of 0.3 m/sec (0.4 ft/sec) to 2.5 m<sup>3</sup>/sec (88.3 cfs) at an approach velocity of 0.9 m/sec (3.0 ft/sec). Water depth in the test flume was maintained between 1.65 and 1.75 m (5.4 and 5.7 ft) (shallower depths were required for conditions that created more head, such as when the louvers were angled at 45 degrees).



**Figure 12-10**  
Plan view of fish testing facility configured for tests with the bar rack and louver arrays angled at 45 degrees to the approach flow (EPRI 2001)



**Figure 12-11**  
Plan view of fish testing facility configured for tests with the bar rack and louver arrays angled at 15 degrees to the approach flow (EPRI 2001)

The louver and bar rack were constructed of plastic using bar slats separated spacers held together by four horizontal cross members. Three sets of spacers were used to create the two spacings (25 and 50 mm [1 and 2 in.] spacing for the racks and 50 mm [2 in.] spacing for the louver array) between slats that were evaluated. The horizontal cross members were 50 mm [2 in.] in diameter, and the slats were 1.8 m by 100 mm by 12.5 mm (5.9 ft by 3.9 in. by 0.5 in.). The 45 degree bar rack and louver arrays were 2.0 m (6.6 ft) long, and the 15 degree array was 4.8 m (15.7 ft) long. A solid overlay was attached to the lower 30 cm (11.8 in.) of the 15 degree bar rack and louver arrays for most of the tests conducted in 2000 in an attempt to improve guidance of bottom-oriented species (e.g., lake sturgeon [*Acipenser fulvescens*] and American eel [*Anguilla rostrata*]).

The downstream end of each array terminated at the bypass entrance, which extended the full depth of the water column and was 15 cm (5.9 in.) wide. The bypass received about 10 to 12% of the total flume flow. A wedgewire screen angled at 16 degrees from the bottom passed most of the bypass flow while guiding fish to a bypass collection box. The collection system for fish entrained through the bar rack and louver arrays consisted of a net that tapered about 6 m (19.7 ft) to a funnel that delivered fish into a collection pen. The mouth of the collection net had a steel frame that was seated in a slot about 0.5 m (1.6 ft) from the downstream end of the rack.

Approach velocities were measured at various vertical transects upstream of the arrays. These velocities were within 10 to 15% of target velocities (i.e. 0.3, 0.6, and 0.9 m/sec [1, 2, and 3 ft/sec]). As expected velocities along the bar racks and louvers increased from the upstream end to the downstream end of the guidance structures. Bypass entrance velocities for the 45 degree arrays were slightly less than the velocities in front of the slats at the downstream end. For the 15 degree arrays, bypass entrance velocities generally were about the same or slightly higher than the velocities at the downstream end of each array. We were able to achieve bypass velocities that were about 1.2 to 1.5 times higher than the approach velocity for tests with the 45 degree structures and about 1.6 to 2.0 for tests with the 15 degree arrays. Head loss data were also collected for all conditions except the 25 mm (1 in.) spaced bar rack tested at 0.3 and 0.6 m/sec (1 and 2 ft/sec). Head loss was greatest for the 45 degree louvers and lowest for the 15 degree bar racks.

Depending on species, between 10 and 50 fish per trial were released between 5.5 and 6.6 m (18 and 21.7 ft) from the upstream end of the arrays. In 1999, the release point was at the surface along the wall opposite the bypass. In 2000, an air injection system released fish near the bottom of the flume and a guide wall directed them toward an interaction with the arrays. Trials ran from 1 to 5 hrs. The lengths of fish evaluated ranged from about 50 to 150 mm (2 to 6 in.) (Table 12-1). Three trials were conducted per approach velocity for most of the array configurations evaluated. Most trials were conducted at night in low-light conditions or complete darkness.

**Table 12-1**

**Fish length data (mm) for species tested with angled bar racks and louvers. Sample sizes (N) are the number of fish measured for length, not the number of fish that were tested (EPRI 2001).**

| Species                 | 1999 Tests |           |         | 2000 Tests |           |         |
|-------------------------|------------|-----------|---------|------------|-----------|---------|
|                         | N          | Mean (SD) | Range   | N          | Mean (SD) | Range   |
| smallmouth bass (small) | 635        | 59 (5)    | 49–86   | 437        | 72 (8)    | 31–108  |
| smallmouth bass (large) | 574        | 85 (11)   | 63–132  | 361        | 117 (13)  | 90–197  |
| largemouth bass         | --         | --        | --      | 1,006      | 73 (4)    | 55–88   |
| walleye                 | --         | --        | --      | 1,061      | 75 (5)    | 28–95   |
| channel catfish         | --         | --        | --      | 800        | 109 (13)  | 81–145  |
| golden shiner           | 1,072      | 79 (6)    | 50–96   | --         | --        | --      |
| lake sturgeon           | 517        | 153 (17)  | 82–194  | 639        | 132 (12)  | 91–161  |
| shortnose sturgeon      | --         | --        | --      | 29         | 319 (31)  | 243–389 |
| American eel            | 388        | 558 (46)  | 151–697 | 324        | 569 (76)  | 410–781 |

The parameters evaluated in 1999 were: (1) bar rack versus louver slat orientation (Figure 12-1); (2) bar slat spacings of 25 and 50 mm (1 and 2 in.) for the bar rack configuration and 50 mm (2 in.) for the louver array; (3) approach velocities of 0.3, 0.6, and 0.9 m/sec (1, 2, and 3 ft/sec) for the two bar rack spacings and 0.3, 0.6, and 0.75 m/sec (1, 2, and 2.5 ft/sec) for the louver configuration (0.9 m/sec [3ft/sec] was not tested with the louvers because of stress on the bow thruster motor and other test facility components); and (4) array angle of 45 degrees to the approach flow. In 2000, the parameters evaluated included: (1) bar slat spacing of 50 mm (2 in.) for both structure types; (2) bar rack array angles of 15 and 90 degrees to the approach flow, louver array angle of 15 degrees and no structure installed (i.e., an open flume); and (3) the presence of a solid bottom overlay placed on the lower 30 cm (11.8 in.) of each structure for most tests.

This evaluation also included a computational fluid dynamics (CFD) analysis. The five configurations chosen for the CFD analysis were: a bar rack at 45 degrees (50 and 25 mm (2 and 1 in.) clear spacing), a bar rack at 15 degrees (50 mm (2 in.) clear spacing), a louver at 45 degrees (50 mm (2 in.) clear spacing, and a louver at 15 degrees (50 mm (2 in.) clear spacing). Both global (for the entire array) and local (for a series of slats) simulations were run to define the flow fields created by the arrays and slats. The results of the CFD simulations indicate that: (1) all bar rack and louver configurations created velocity and pressure gradients that could elicit a directional avoidance response by fish; (2) the magnitude and related influence of the flow separation between consecutive louver or bar slats was the most distinct difference between the configurations simulated; (3) pressure gradients were not substantially different between the 15-degree and 45-degree bar rack configurations simulated; (4) the local pressure gradient near the leading edge of the 45-degree louver slat was higher than the local pressure gradient near the leading edge of the 15-degree louver slat; and (5) 45 degree bar rack and louver configuration simulations reveal hydraulic conditions favorable for fish guidance, however, laboratory estimated fish guidance was poor at this angle.

The results of the biological evaluation are presented in Table 12-2. Overall, tests conducted at the 0.6 m/sec (2 ft/sec) approach velocity demonstrated that the 15 degree angle (with and without the bottom overlay installed) produced the highest fish guidance efficiencies (FGEs) for the species that were evaluated with more than one angle. The next highest guidance rates were observed with the 45 degree arrays and the lowest guidance rates of all the arrays that were evaluated occurred with the 90-degree bar rack. When all test conditions are considered, the lowest FGEs were observed when there was no structure in the flume (i.e., control condition), indicating that all of the guidance array configurations that were evaluated produced some level of diversion to the bypass above what might result from random distribution of fish in the flume. It was also shown that the use of the overlay along the bottom of the 15-degree arrays increased FGEs at approach velocities of 0.6 m/sec (2 ft/sec).

Slat orientation had a negligible effect on FGEs. However, slat spacing did affect FGEs. Guidance efficiencies of American eel and freshwater species were lower for the 25 mm (1 in.) spacing than for the 50 mm (2 in.) spacing (45 degree angle) at a velocity of 0.3 m/sec (1 ft/sec), whereas lake sturgeon FGE was higher for the 25 mm (1 in.) spacing. At 0.6 m/sec (2 ft/sec), the FGEs of freshwater species and lake sturgeon were considerably higher for the 25 mm (1 in.) spacing; FGE of American eel at this velocity was nearly the same for the two spacings. At a velocity of 0.9 m/sec (3 ft/sec), the difference between the guidance rates for the two spacings (with guidance still being greater with the 25 mm (1 in.) spacing) increased even more for freshwater species. Lake sturgeon FGE at this velocity was 0% for both spacings.

Guidance efficiency rates exhibited an inverse relationship with approach velocity during tests with the 15- and 45-degree arrays. The highest FGEs for shortnose sturgeon (*Acipenser brevirostrum*), lake sturgeon, and potamodromous species occurred at an approach velocity of 0.3 m/sec (1 ft/sec) and the lowest efficiencies occurred at 0.9 m/sec (3 ft/sec); American eel FGE peaked at 0.6 m/sec (2 ft/sec) and was lowest at 0.9 m/sec (3 ft/sec). The differences in guidance rates between the lowest and highest velocities were greater for freshwater species and lake sturgeon than for shortnose sturgeon and American eel. These differences in FGE for the upper and lower velocities appeared to be related to fish size, as the freshwater species and lake sturgeon all averaged less than 200 mm (7.9 in.) in length and shortnose sturgeon and American eel averaged greater than 300 mm (11.8 in.) in length. In general, FGE increased with fish length for all three approach velocities regardless of rack angle.

The results of this study indicate that bar rack and louver arrays angled at 45 degrees to the approach flow do not effectively guide potamodromous fishes and silver American eels. Consequently, the application of these devices for fish protection purposes at hydro projects may be limited. Bar rack and louver arrays angled at 15 degrees appear to have potential for relatively high bypass diversion rates depending on approach velocities and species and sizes targeted for protection. However, the authors point out that these evaluations were conducted under ideal laboratory conditions using a full-depth bypass and relatively short lengths of bar racks and louvers and may have produced guidance efficiency estimates that are higher than would be expected for a field application.



**Table 12-2**

**Summary of guidance efficiencies for bar rack and louver tests. Slat clear spacing for each structure is listed in parentheses. Species codes are: SMB, smallmouth bass; WAL, walleye; LMB, largemouth bass; CHA, channel catfish; GSH, golden shiner; LAS, lake sturgeon; SNS, shortnose sturgeon; EEL, American eel (EPRI 2001).**

| Guidance Structure     | Bottom Overlay | Velocity (m/s) | Fish Guidance Efficiency (%) |      |      |      |      |      |       |      |
|------------------------|----------------|----------------|------------------------------|------|------|------|------|------|-------|------|
|                        |                |                | SMB                          | WAL  | LMB  | CHA  | GSH  | LAS  | SNS   | EEL  |
| 45° bar rack (25 mm)   | no             | 0.3            | 31.2                         | --   | --   | --   | 56.1 | 27.3 | --    | 65.1 |
|                        |                | 0.6            | 51.4                         | --   | --   | --   | 52.6 | 18.3 | --    | 56.8 |
|                        |                | 0.9            | 49.3                         | --   | --   | --   | 37.1 | 0.0  | --    | 65.9 |
| 45° bar rack (50 mm)   | no             | 0.3            | 49.6                         | --   | --   | --   | 51.3 | 20.4 | --    | 72.7 |
|                        |                | 0.6            | 30.8                         | --   | --   | --   | 27.9 | 10.0 | --    | 57.8 |
|                        |                | 0.9            | 20.3                         | --   | --   | --   | 13.1 | 0.0  | --    | 54.5 |
| 15° bar rack (50 mm)   | no             | 0.3            | --                           | --   | 67.8 | 94.2 | --   | --   | --    | --   |
|                        |                | 0.6            | 69.7                         | 57.1 | 58.3 | 75.6 | --   | 10.4 | --    | 83.3 |
|                        |                | 0.9            | --                           | --   | 58.3 | 73.5 | --   | --   | --    | --   |
| 15° bar rack (50 mm)   | yes            | 0.3            | 71.6                         | 79.2 | --   | --   | --   | 27.5 | 100.0 | 95.1 |
|                        |                | 0.6            | 80.4                         | 78.2 | --   | --   | --   | 17.4 | 100.0 | 95.0 |
|                        |                | 0.9            | 76.3                         | 63.2 | --   | --   | --   | 2.9  | 92.9  | 88.9 |
| 45° louver (50 mm)     | no             | 0.3            | 43.0                         | --   | --   | --   | 29.5 | 28.0 | --    | 34.9 |
|                        |                | 0.6            | 47.3                         | --   | --   | --   | 34.6 | 0.0  | --    | 61.9 |
|                        |                | 0.9            | 13.7                         | --   | --   | --   | 22.1 | 1.7  | --    | 45.1 |
| 15° louver (50 mm)     | no             | 0.3            | --                           | --   | 73.3 | 82.5 | --   | --   | --    | --   |
|                        |                | 0.6            | 55.7                         | 51.3 | 71.6 | 73.4 | --   | 16.2 | --    | 60.0 |
|                        |                | 0.9            | --                           | --   | 60.4 | 69.9 | --   | --   | --    | --   |
| 15° louver (50 mm)     | yes            | 0.3            | 88.0                         | 90.6 | --   | --   | --   | 36.8 | 100.0 | 88.6 |
|                        |                | 0.6            | 84.9                         | 75.4 | 87.3 | 93.8 | --   | 15.9 | 96.0  | 95.1 |
|                        |                | 0.9            | 88.8                         | 62.6 | --   | --   | --   | 7.4  | 93.3  | 90.2 |
| 90° bar rack (50-mm)   | yes            | 0.6            | 53.3                         | 8.4  | --   | --   | --   | 0.0  | --    | --   |
| no structure installed | --             | 0.6            | 29.1                         | 0.0  | --   | --   | --   | 0.0  | --    | --   |

### **Laboratory Evaluation – EPRI**

Many North American sturgeon populations have experienced considerable declines over the last century, including lake and shortnose sturgeon (*Acipenser fulvescens* and *Acipenser brevirostrum*). This study, which was conducted as part of the EPRI study described above, examined the ability of these species to guide along angled diversion structures and into a bypass entrance. Specifically, the study examined sturgeon guidance along angled bar racks (25 and 50 mm [1 and 2 in.] clear slat spacing) and louvers (50-mm [2-in.] clear spacing). The slats were oriented perpendicular to the flow to create the louver arrangement and perpendicular to the support structure to create the bar rack configuration. Other primary variables included rack and louver angle to the approach flow (90, 45, and 15 degrees) and approach flow velocity (0.3, 0.6, 0.75, and 0.9 m/sec [1, 2, 2.5, and 3 ft/sec]). Tests were conducted in a large, laboratory flume measuring 24.4 by 1.7 by 2.1 m (80.1 by 5.6 by 6.9 ft). The 15- and 45-degree louver arrays were set in the flume to guide fish to a 15.2 cm (6 in.) bypass at the downstream end of each array. In 2000, a solid bottom overlay covered the lower 30 cm (11.8 in.) of the 15-degree louver arrangements (Amaral et al. 2002b).

The average total length (TL) of young-of-the-year (YOY) lake sturgeon was 153 mm (6 in.) (1999) and 132 mm (5.2 in.) (2000). The average total length (TL) of age-1 lake sturgeon was 345 mm (13.6 in.). The average TL of age-1 shortnose sturgeon was 319 mm (12.6 in.). Mean guidance efficiency was low with YOY lake sturgeon for all 45 degree angle configurations and velocities tested in 1999, ranging from 0% to a high of 28%. Observations indicated that these fish had limited ability to avoid the guidance devices and passed through them with little effort to guide. In contrast, age-1 lake and shortnose sturgeon demonstrated excellent guidance efficiencies, exceeding 90% at all velocities with the 15-degree bar rack and louver. These data are summarized in Table 2-3 and Table 12-4 below (Amaral et al. 2002b). These results indicate that angled bar racks and louvers have potential for guiding larger sturgeon to bypasses.

**Table 12-3**

Summary of results from age-1 lake sturgeon tests with bar racks and louvers angled 15 degrees to the approach flow. Both structure types had 50-mm clear spacing between the slats and the bottom overlay was used in all tests (Amaral et al. 2002b).

| Approach Velocity (m/s)    | Number of trials (N) | Number of fish released | Number of fish entrained | Number of fish bypassed | Total recovered | Percent recovery | Mean guidance efficiency (%) (SE) |
|----------------------------|----------------------|-------------------------|--------------------------|-------------------------|-----------------|------------------|-----------------------------------|
| Bar rack (nighttime tests) |                      |                         |                          |                         |                 |                  |                                   |
| 0.3                        | 3                    | 97                      | 0                        | 65                      | 65              | 67.0             | 100.0 (0.0)                       |
| 0.6                        | 3                    | 98                      | 4                        | 85                      | 89              | 90.8             | 95.4 (3.2)                        |
| 0.9                        | 3                    | 98                      | 7                        | 89                      | 95              | 98.0             | 93.1 (5.2)                        |
|                            |                      |                         |                          |                         |                 |                  |                                   |
| Louver (nighttime tests)   |                      |                         |                          |                         |                 |                  |                                   |
| 0.3                        | 3                    | 98                      | 0                        | 66                      | 66              | 67.3             | 100.0 (0.0)                       |
| 0.6                        | 3                    | 96                      | 5                        | 90                      | 95              | 99.0             | 94.8 (0.9)                        |
| 0.9                        | 3                    | 100                     | 15                       | 83                      | 98              | 98.0             | 84.8 (2.5)                        |
|                            |                      |                         |                          |                         |                 |                  |                                   |
| Louver (daytime tests)     |                      |                         |                          |                         |                 |                  |                                   |
| 0.60                       | 3                    | 98                      | 1                        | 74                      | 75              | 76.5             | 98.8 (1.2)                        |

**Table 12-4**

**Summary of results from shortnose sturgeon tests with bar racks and louvers angled 15 degrees to the approach flow. Both structure types had 50-mm clear spacing between slats (Amaral et al. 2002b).**

| Approach Velocity (m/s)       | Number of trials (N) | Number of fish released | Number of fish entrained | Number of fish bypassed | Total recovered | Percent recovery | Mean guidance efficiency (%) (SE) |
|-------------------------------|----------------------|-------------------------|--------------------------|-------------------------|-----------------|------------------|-----------------------------------|
| Bar rack with bottom overlay  |                      |                         |                          |                         |                 |                  |                                   |
| 0.3                           | 3                    | 30                      | 0                        | 8                       | 8               | 26.7             | 100.0 (0.0)                       |
| 0.6                           | 3                    | 30                      | 0                        | 14                      | 14              | 46.7             | 100.0 (0.0)                       |
| 0.9                           | 3                    | 30                      | 2                        | 26                      | 28              | 93.3             | 92.6 (7.4)                        |
| Louver with bottom overlay    |                      |                         |                          |                         |                 |                  |                                   |
| 0.3                           | 3                    | 30                      | 0                        | 15                      | 15              | 50.0             | 100.0 (0.0)                       |
| 0.6                           | 3                    | 30                      | 1                        | 24                      | 25              | 83.3             | 95.2 (4.8)                        |
| 0.9                           | 3                    | 30                      | 2                        | 28                      | 30              | 100.0            | 93.3 (3.3)                        |
| Louver without bottom overlay |                      |                         |                          |                         |                 |                  |                                   |
| 0.6                           | 1                    | 10                      | 0                        | 3                       | 3               | 30.0             | 100.0 (-)                         |
| 0.9                           | 1                    | 10                      | 1                        | 5                       | 6               | 60.0             | 83.3 (-)                          |

**Laboratory Evaluation – EPRI**

Little information has been available on the ability of American eels (*Anguilla rostrata*) to guide along diversion systems that might prevent them from being injured or killed as a result of passage through hydroelectric facilities. This laboratory study, which was conducted as part of the larger EPRI study described previously, examined eel guidance along angled bar racks (25 and 50 mm [1 and 2 in.] clear slat spacing) and louvers (50 mm [2 in.] clear spacing) (Amaral et al. 2003). The slats were oriented perpendicular to the flow to create the louver arrangement and perpendicular to the support structure to create the bar rack configuration. The rack and louver arrays were tested at angles of 45 and 15 degrees to the approach flow and at velocities of 0.3, 0.6, 0.75, and 0.9 m/sec (1, 2, 2.5, and 3 ft/sec). The test flume was 24.4 by 1.7 m by 2.1 m (80.1 by 5.6 by 6.9 ft). The 15- and 45-degree louver arrays were set in the flume to guide fish to a 15.2-cm (6-in.) bypass at the downstream end of each array. In 2000, a solid bottom overlay covered the lower 30 cm (11.8 in.) of the 15-degree louver arrangements.

Test eels averaged 558 mm (22 in.) (1999) and 569 mm (22.4 in.) in length (2000). Because eels are sensitive to light, tests were conducted at night. Three trials were conducted per approach velocity for most bar rack and louver configurations. Mean E was greater than 50% for the two bar rack spacing (25 and 50 mm [1 and 2 in.]) at all test velocities and for tests at 0.6 m/sec (2 ft/sec) with the louver array. These data are summarized in Table 12-5 and Table 12-6 (Amaral et al. 2003). These results indicate that angled bar racks and louvers have potential for guiding downstream-migrating silver eels to a bypass, particularly with the array angles at 15 degrees to

the approach flow. Up to 75% of eels were diverted with the 45-degree racks and louvers, and up to 95% were diverted with the 15-degree array.

**Table 12-5**  
**Summary of results from American eel guidance trials with bar racks and louvers angled 45 degrees to the approach flow (Amaral et al. 2003).**

| Approach Velocity (m/s)         | Number of trials (N) | Number of fish released | Number of fish entrained | Number of fish bypassed | Total recovered | Percent recovery | Mean guidance efficiency (%) (SE) |
|---------------------------------|----------------------|-------------------------|--------------------------|-------------------------|-----------------|------------------|-----------------------------------|
| 45° Bar rack with 25-mm spacing |                      |                         |                          |                         |                 |                  |                                   |
| 0.3                             | 3                    | 45                      | 15                       | 28                      | 43              | 95.6             | 64.8 (8.0)                        |
| 0.6                             | 3                    | 45                      | 19                       | 25                      | 44              | 97.8             | 56.5 (7.0)                        |
| 0.9                             | 3                    | 45                      | 15                       | 29                      | 44              | 97.8             | 65.9 (12.0)                       |
| 45° Bar rack with 50-mm spacing |                      |                         |                          |                         |                 |                  |                                   |
| 0.3                             | 3                    | 45                      | 12                       | 32                      | 44              | 97.8             | 72.5 (5.0)                        |
| 0.6                             | 3                    | 45                      | 19                       | 26                      | 45              | 90.0             | 57.8 (4.0)                        |
| 0.9                             | 3                    | 45                      | 20                       | 24                      | 44              | 97.8             | 53.3 (3.0)                        |
| 45° Louver with 50-mm spacing   |                      |                         |                          |                         |                 |                  |                                   |
| 0.30                            | 3                    | 45                      | 28                       | 14                      | 42              | 93.3             | 33.3 (2.0)                        |
| 0.60                            | 3                    | 45                      | 16                       | 26                      | 42              | 93.3             | 62.1 (4.0)                        |
| 0.75                            | 3                    | 45                      | 24                       | 20                      | 44              | 97.8             | 45.4 (4.0)                        |

**Table 12-6**  
**Summary of results from American eel guidance trials with bar racks and louvers angled 15 degrees to the approach flow. The clear spacing of all 15 degree bar rack and louver configurations was 50 mm (Amaral et al. 2003).**

| Approach Velocity (m/s)             | Number of trials (N) | Number of fish released | Number of fish entrained | Number of fish bypassed | Total recovered | Percent recovery | Mean guidance efficiency (%) (SE) |
|-------------------------------------|----------------------|-------------------------|--------------------------|-------------------------|-----------------|------------------|-----------------------------------|
| 15° Bar rack with bottom overlay    |                      |                         |                          |                         |                 |                  |                                   |
| 0.3                                 | 3                    | 45                      | 2                        | 39                      | 41              | 91.1             | 95.1 (3.0)                        |
| 0.6                                 | 3                    | 45                      | 2                        | 38                      | 40              | 88.9             | 95.2 (24.0)                       |
| 0.9                                 | 3                    | 45                      | 5                        | 40                      | 45              | 100.0            | 88.9 (4.0)                        |
| 15° Bar rack without bottom overlay |                      |                         |                          |                         |                 |                  |                                   |
| 0.6                                 | 2                    | 30                      | 4                        | 20                      | 24              | 80.0             | 83.3 (0.00)                       |
| 15° Louver with bottom overlay      |                      |                         |                          |                         |                 |                  |                                   |
| 0.3                                 | 3                    | 45                      | 5                        | 39                      | 44              | 97.8             | 88.7 (4.0)                        |
| 0.6                                 | 3                    | 45                      | 2                        | 39                      | 41              | 91.1             | 95.2 (2.0)                        |
| 0.9                                 | 3                    | 45                      | 4                        | 37                      | 41              | 91.1             | 90.3 (2.0)                        |
| 15° Louver without bottom overlay   |                      |                         |                          |                         |                 |                  |                                   |
| 0.6                                 | 3                    | 45                      | 14                       | 21                      | 35              | 77.8             | 60.7 (4.0)                        |

**Laboratory Evaluation - Conte Anadromous Fish Research Center**

Bar racks and louvers were evaluated in a laboratory flume to determine guidance efficiency and behavior for shortnose and pallid sturgeon (*Acipenser brevirostrum* and *Scaphirhynchus albus*) (Kynard and Horgan 2001). The test flume was 5.4 by 1.5 m (17.7 by 4.9 ft) with a water depth of 37 cm (14.6 in.). One vertical bar rack configuration with slats spaced 3.9 cm (1.5 in.) apart (clear spacing) was tested. The bar rack slats were oriented parallel to the approach flow, and the structure was oriented at a 45 degree angle to the flow. Two louver array configurations were tested, one with slats spaced 3.9 cm (1.5 in.) apart and one with slats spaced 9.0 cm apart (3.5 in.) (clear spacing). The louver slats were oriented at a 90 degree angle to the flow, and the structure was oriented at a 20 degree angle to the approach flow. Mean approach velocity to both structures was 0.31 to 0.34 m/sec (1.02 to 1.12 ft/sec).

The total lengths (TL) of test fish were as follows (mean, SD, and range): shortnose sturgeon (275, 26, and 238 to 315 mm) and pallid sturgeon (216, 23, and 174 to 273 mm). The shortnose sturgeon were tagged with passive integrated transponders (PIT tags) to track their movements during each test. Eighteen shortnose and 24 to 38 pallid sturgeon were tested in each configuration. Each shortnose sturgeon individual was tested in all four configurations, whereas individual pallid sturgeon were tested in one bar rack and one louver configuration at most.

One-half of the shortnose sturgeon were tested first with the bar rack at night, and the other one-half were tested first with the bar rack during the day. Each group of shortnose sturgeon was then retested with the bar rack during the alternate time period. This sequence was chosen to detect effects of experience on guidance behavior. Pallid sturgeon were not individually marked. After each test, fish were measured for TL and shortnose sturgeon were checked for PIT tag number.

Both sturgeon species were guided efficiently by the louver array (96 to 100%) but less efficiently by the bar rack (58 to 80%). Shortnose sturgeon showed some behavioral differences due to experience with the bar rack, but experience did not affect the percent guided. Shortnose sturgeon were more likely to contact the bar rack at night than during the day; at night, they were more likely to contact the bar rack than the louver array. The bar racks guided fewer individuals at night than during the day. For pallid sturgeon, the guidance efficiency by day and night was 80 and 58%, respectively; for shortnose sturgeon, the efficiency was 80 and 67%.

### **Laboratory Evaluation - Conte Anadromous Fish Research Center**

An experimental louver bypass system was constructed and tested in a flume at the Conte Anadromous Fish Research Center (US Geological Survey) in Massachusetts (Kynard and Buerkett 1997). The laboratory system was used to evaluate guidance and passage efficiency and response of American shad (*Alosa sapidissima*) (juveniles and adults) to stimuli from physical structures, light intensity, and water velocity.

The test flume was 39.6 of 6.1 by 6.1 m (130 by 20 by 20 ft). Water enters the flume by gravity via a power canal. A 2.4 m (7.9 ft) high wooden weir (downstream end) and a barrier net (upstream end) restricted fish to 26 m (85 ft) long test area in the flume. Water level in the test area varied slightly between 2.1 and 2.3 m (6.9 and 7.5 ft). The vertical louver array was constructed of wood and positioned at 20 degrees to the flow. The array consisted of a series of vertical slats measuring 2.4 m by 14 cm by 1.3 cm (7.7 ft by 5.5 in. by 0.5 in.) thick. Spacing of the louvers could be adjusted from 7.6 to 15.2 cm (3 to 6 in.) by removing or replacing alternate louver slats. Louver slats were oriented 90 degrees to the approach flow and extended from the floor of the flume to above the water surface. Two types of bypass exits were evaluated: a sharp-crested weir type (122 cm [48 in.] wide by 91 cm [35.8 in.] deep) and a vertical-slot exit (46 cm [18.1 in.] wide by 183 cm [72 in.] deep).

A total of 436 fish were introduced into the flume during 40 trials. Test fish were collected from the Connecticut River and included juvenile and adult American shad, depending upon seasonal availability during testing of each set of conditions. There was no difference in the guidance efficiency between the two louver types: the narrow array prevented 100% of the fish from passing through the slats, and the wide array prevented 97% of the fish from passing. There also was no difference in results between the two bypass types. Adults avoided moving closer than 0.5 m to either exit type. However, there were some differences depending upon the lighting conditions. In general fish remained further upstream during daylight periods than at night.

### **Laboratory Study – Alden Research Laboratory**

Laboratory testing with louvers was conducted with alewife and smelt in a 0.91 by 0.91 m (3 ft by 3 ft) flume at Alden previously described in the Angled Screen chapter (Table 10-6). These tests were conducted for Niagara Mohawk (Taft and Mussalli 1978). Consolidated Edison

sponsored separate studies with striped bass (*Morone saxatilis*), white perch (*Morone americana*), and tomcod (*Microgadus tomcod*) (Taft and Mussalli 1978; Table 10-6). Tests were conducted in a manner similar to that described for the angled screen studies. However, mortality was not evaluated during louver testing. Therefore, efficiency of the louvers was defined as the number of fish that were successfully diverted to a bypass relative to the total number released upstream.

A total of 45 tests were conducted with alewife (*Alosa pseudoharengus*) and rainbow smelt (*Osmerus mordax*) in the 0.91 m (3 ft) flume. Based on past experience, an approach-to-bypass velocity ratio of 1.0:1.5 was established in all tests. Therefore, at the three test approach velocities of 0.31, 0.46, and 0.61 m/sec (1.0, 1.5, and 2.0 ft/sec), bypass velocities were set at 0.46, 0.70, and 1.07 m/sec (1.5, 2.3, and 3.5 ft/sec), respectively. Louver array angles of 90, 60, and 25 degrees to the flow and louver slat spacings of 25, 51, and 82.6 mm (1.0, 2.0, and 3.25 in.) were evaluated at these different velocities.

At angles of 90 and 60 degrees, average guidance efficiency was less than 80%. Therefore, more extensive studies were conducted with a 25 degree orientation. At this angle, with a louver slat spacing of 25 mm (1 in.) the average efficiency of the system in diverting alewife and smelt was 90 and 93%, respectively.

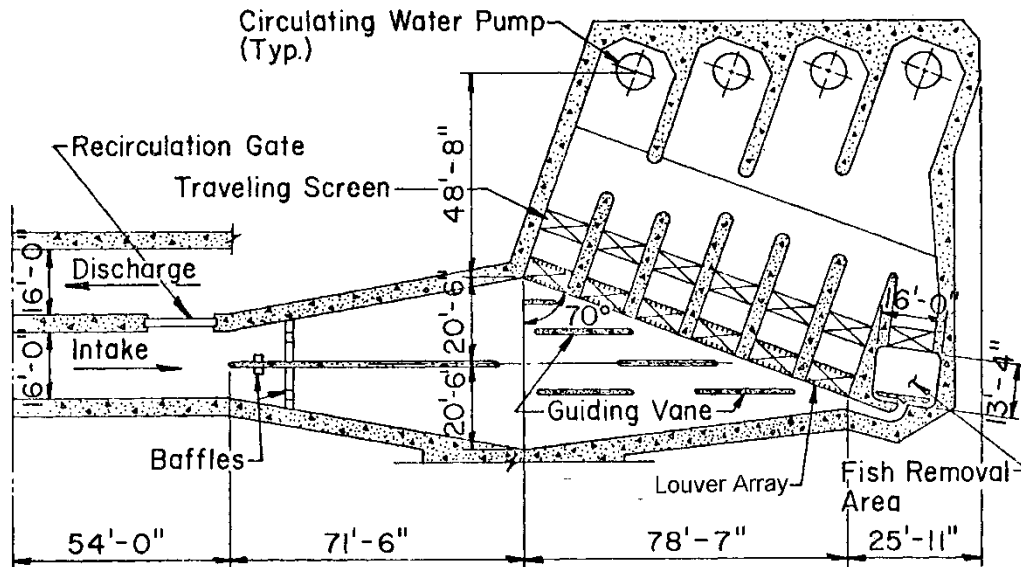
For tests conducted in the 1.83 m (6 ft) flume with striped bass, white perch, and tomcod, the louver system was evaluated with slat spacings of 25 mm (1 in.) and an orientation of 25 degrees only. The approach velocities were 0.31, 0.61, and 0.91 m/sec (1.0, 2.0, and 3.0 ft/sec), and the corresponding bypass velocities were 0.46, 0.91, and 1.37 m/sec (1.5, 3.0, and 4.5 ft/sec). The efficiency of the louvers was found to be species-specific, ranging from 50 to 80% for white perch, 56 to 97% for Hudson River striped bass, 68 to 99% for hatchery-reared striped bass, and 96 to 99% for tomcod (Taft and Mussalli 1978). The average efficiency for all species combined was 84.7%.

### **Laboratory Study – Redondo Beach Generating Station**

Schuler (1973) tested various louver configurations with 18 species of fish, including Northern anchovy (*Engraulis mordax*), queenfish (*Seriophilus politus*), white croaker (*Genyonemus lineatus*), walleye (*Sander vitreus*), surfperch (Embiotocidae), and shiner perch (*Cymatogaster aggregate*), in a test flume at Southern California Edison's Redondo Beach Station. Approach velocities ranged from 0.15 to 1.22 m/sec (0.5 to 4 ft/sec). The louvers were placed at angles ranging from 90 degrees to 20 degrees to the direction of flow. Maximum guidance (96 to 100%) occurred with louver slats spaced 2.5 cm (1 in.) apart, set at 20 degree orientation to the flow, with flow vanes normal (90 degrees) to the frame and an approach velocity of 0.6 m/sec (2 ft/sec). Schuler (1973) also determined that the configuration of the bypass channel was as important as louver and velocity settings to successfully divert fish. Test specimens would move into the bypass channel only if the flow in the bypass was free of turbulence. Bypass channel velocities should be at least 1.5 times the approach velocity and probably should be higher than the sustained swimming speed of target species and size classes. Schuler (1973) also presented the only data that indicate higher guidance efficiencies are achieved with louver slats placed normal to the frame rather than normal to the flow. In addition, it was found that the system worked equally well in light or in darkness (Schuler 1973; Schuler and Larson 1975).



This flume study led to the development and installation of a traveling louver system at Southern California Edison's San Onofre Nuclear Generating Station (SONGS). The station is located near the San Diego-Orange County line in California. Its once-through cooling system includes intake structures situated approximately 1 km (0.62 mi) from shore at a depth of 9 m (29.5 ft). The intakes have a wide lower lip and velocity cap and the plant relies on a fish return system to mitigate fish entrapment. The two units (served by four circulating water pumps) each have a capacity to draw water at 50.5 m<sup>3</sup>/sec (1,783 cfs). A system of guiding vanes and louvers direct fish away from the banks of traveling screens into a collection area (Figure 12-12). Velocity through the screens is 0.6 to 0.9 m/sec (2 to 3 ft/sec). Maximum velocity into the return system is 2.1 m/sec (7 ft/sec). Biological effectiveness data for this facility could not be found.



**Figure 12-12**  
**Louver system at SONGS (EPRI 1987)**



# 13

## LIGHTS

### Introduction

Several types of light have been investigated as a method for attracting or repelling fish. Results have varied depending largely upon light source and intensity, species, and water clarity. The majority of tests have been conducted with strobe and mercury light. The relative success of lights to illicit a behavioral response in juvenile and adult fish is discussed individually below by type of light.

### Strobe Lights

Strobe or flashing light has been intensively evaluated for repelling or guiding fish away from hydroelectric facilities and water intakes, and in many cases, toward bypasses for transport to a safe release location. Early studies with light examined the response of salmonids to both flashing and continuous sources (Brett and MacKinnon 1953; Craddock 1956). The results from these studies indicated that flashing light produced stronger avoidance reactions than continuous light, and that responses appeared to be affected by species tested, developmental stage (i.e., age or size of fish), and adaptation light level (Feist and Anderson 1991). More recent studies with salmonids have corroborated these findings (Puckett and Anderson 1988; EPRI 1990; Nemeth and Anderson 1992).

Examination of the deterrent potential of strobe light expanded considerably in the 1980s. Laboratory studies were conducted with anadromous salmonids and *Alosa* species, several potamodromous and estuarine species, and the catadromous American eel (*Anguilla rostrata*). These studies involved both controlled experiments (laboratory and cage tests) and field efforts. Extensive research with strobe lights has continued, including laboratory and/or cage test evaluations with Pacific salmon, American eel, and several freshwater species, open water tests with Kokanee salmon (*Oncorhynchus nerka*), and field tests with freshwater species and Atlantic salmon (*Salmo salar*).

The concept of strobe light as a fish protection technology is based on its potential to elicit an avoidance response from fish resulting in a change in behavior that prevents CWIS involvement or turbine entrainment. This concept is supported by the results of many laboratory and cage test strobe light studies that have demonstrated strong avoidance by several fish species. Taking the strobe light concept to the next level (i.e., successful field applications) has proven to be more difficult. Field studies have shown that some species and life stages can be repelled by strobe light, but results from these efforts have been less consistent and more difficult to interpret due to confounding factors associated with environmental conditions and plant design and operating parameters.

The design and manufacturing of strobe lights used in fish protection studies has varied, but most studies conducted since 1992 have used light systems supplied by Flash Technology Corporation. Other manufacturers of flash heads that have been used in past studies include

EG&G and Huey Philips. Off-the-shelf strobe lights modified for underwater applications were used in earlier studies conducted prior to 1992. Therefore, results from these earlier studies can be difficult to compare with results of more recent studies conducted with lights specifically designed for underwater use. Improvements to the nascent science of using strobe lights for fish protection have brought about more conclusive, more repeatable, and oftentimes more favorable results than some of these earlier studies. Flash Technology Corporation, for example, has developed strobe lighting systems designed specifically for fish protection applications to depths of 80 m (262.5 ft). A typical system consists of strobe light flash heads, associated wiring, power supplies, and a computer-operated control system.

Although many studies have evaluated strobe lights as a primary barrier system, they are often evaluated as part of an integrated fish protection and passage system that includes other devices such as screens, narrow-spaced bar racks, bypasses, and/or other behavioral systems (EPRI 1999). As a secondary system, strobe lights have the potential to incrementally increase fish protection effectiveness.

In designing a strobe light array for a specific site, careful consideration must be given to site physical, hydraulic, and environmental characteristics. The primary consideration is whether strobe light has been shown to be effective in repelling the species of concern. Most often, laboratory or field cage tests or small-scale pilot studies have been performed to verify fish response and determine optimum parameters for repulsion (e.g., flash rate, intensity, direction of light). Once these studies are completed, it is appropriate to move to larger-scale applications where other parameters that might affect performance can be evaluated (e.g., turbidity, flow velocity, bypass configuration). This approach generally has been followed in the many strobe light evaluations conducted to date, as presented in the following discussion.

Controlled experiments and field tests with potamodromous fish (e.g., basses [Centrarchidae], yellow perch [*Perca flavescens*], shiners, carps [Cyprinidae]) have produced mixed results with no clear trends related to species tested (EPRI 1992b). During two field efforts conducted at low-head hydro projects, one study demonstrated that strobe lights significantly reduced entrainment of bullhead (*Ameiurus spp.*) and shiner species, whereas the other study determined that strobe lights were ineffective at repelling juveniles of potamodromous species from one of the project's turbine intakes. Based on study results to date, strobe lights may not be appropriate for projects that require protection for certain potamodromous species.

While there has been a great deal of research conducted on the biological effectiveness of strobe lights, there are relatively few permanent installations to date. However, there are two sites that have effectively demonstrated the applicability of strobe lights as viable fish protection technologies: the Hiram M. Chittenden Locks in Washington and the Dworshak Dam in Idaho. At the Chittenden Locks, preliminary data analysis indicated that strobe lights had been effective in repelling juvenile Pacific salmon from a filling culvert. Consequently, a strobe light system was installed as a permanent protection measure for this site and was shown to significantly decrease the entrainment of juvenile salmonids.

Open water testing at Lake Pend Oreille and Spirit Lake demonstrated that free ranging Kokanee salmon were repelled up to a distance of 120 m (393.7 ft) from underwater strobe lights. In addition, preliminary results of recent evaluations of this strobe light system have shown a significant reduction in Kokanee densities near the turbine intakes (Maiolie pers. comm. 2004) at Dworshak Dam.

Results of evaluations at other sites remain somewhat inconclusive. For example, results from field tests at the Milliken Station were mixed in past years, with some species and age classes being repelled by strobe light and others being attracted. Due to the unclear results, confounded by small sample sizes, the strobe light system at this site has not undergone any recent evaluations. Similarly, the strobe light system installed at the Mattaceunk Project was part of an effort to develop permanent downstream passage facilities for Atlantic salmon smolts and kelts. Efficiency of the entire passage system (i.e., bypass collection box, strobe lights) has varied among study years. Comparison of results from control samples (1993 and 1994) to test samples (1995 and 1997) revealed an increase in guidance to the bypass entrance of 19% with the use of the strobe lights (Brown 1997).

Additional research is needed to expand the growing database on the species, life stages, and environmental conditions (e.g., flows, turbidity, and diel period) for which strobe lights are most applicable. While the potential of strobe lights has been demonstrated with various salmonid species, further research addressing the potential for use with non-salmonid species is needed. Field studies need to focus on determining important engineering (number of lights and location, project hydraulics) and environmental (water turbidity, ambient light conditions) parameters that may influence the success of strobe light systems. The sites where studies have been conducted are diverse, which makes comparative interpretation of results difficult.

**Table 13-1**  
**Summary of strobe light testing conducted during field, cage, and laboratory studies**

| Site and Reference                                                                                                       | Target/<br>Abundant<br>Species | Flash Rates<br>Evaluated<br>(fl/min)                                | Ambient<br>Light<br>Conditions | Turbidity<br>Conditions<br>(NTU) | General Study Conclusions                                                                                                                                                                                                         |
|--------------------------------------------------------------------------------------------------------------------------|--------------------------------|---------------------------------------------------------------------|--------------------------------|----------------------------------|-----------------------------------------------------------------------------------------------------------------------------------------------------------------------------------------------------------------------------------|
| <b>Cooling Water Intake Field Tests</b>                                                                                  |                                |                                                                     |                                |                                  |                                                                                                                                                                                                                                   |
| Milliken Station<br>Ichthyological Assoc. (1994,<br>1997)                                                                | freshwater spp                 | 300                                                                 | day, dusk,<br>night            | Not<br>Reported<br>(NR)          | Results from two study years were mixed; some species were attracted to the strobe light and others repelled. Species-specific responses varied with season and fish age.                                                         |
| Roseton Station<br>EPRI (1998b)<br>Matousek et al. (1988a, b)                                                            | riverine<br>anadromous<br>spp  | 400, 500,<br>600(EPRI<br>1998b)<br>200(Matousek<br>et al 1988a, b). | 24-hour<br>testing             | NR                               | Strobe light alone and in combination with a pneumatic popper and an air bubble curtain demonstrated an ability to reduce impingement of most fish species. Reductions in impingement were greater for combined device operation. |
| <b>Hydroelectric/Water Diversion Field Tests</b>                                                                         |                                |                                                                     |                                |                                  |                                                                                                                                                                                                                                   |
| Mattaceunk (Weldon Dam)<br>Georgia-Pacific Corp. (1989,<br>1990)<br>Great Northern Paper (1995,<br>1998)<br>Brown (1997) | Atlantic salmon                | 200 (1998-89)<br>NR (1993-98)                                       | 24-hour<br>testing             | NR                               | Strobe lights installed on the intakes of Units 1 and 2 appear to repel smolts into Units 3 and 4. Strobe lights on the lower half of Units 3 and 4 did not lead to increases in surface bypass use.                              |
| White Rapids<br>EPRI (1998b)<br>Michaud and Taft (2000)                                                                  | riverine spp                   | 400                                                                 | 24-hour<br>testing             | 3.92-9.34                        | No detectable reduction in fish entrainment during three sample periods (July, September, and October).                                                                                                                           |
| Four Mile Dam<br>GLEC (1994)<br>McCauley (1996)                                                                          | bullhead spp<br>shiner spp     | 60 (1994)<br>NR (1995)                                              | 24-hour<br>testing             | NR                               | During certain times of day, entrainment of bullhead and shiner species was lower when strobe lights were operating.                                                                                                              |

| Site and Reference                                                                               | Target/<br>Abundant<br>Species      | Flash Rates<br>Evaluated<br>(fl/min) | Ambient<br>Light<br>Conditions | Turbidity<br>Conditions<br>(NTU) | General Study Conclusions                                                                                                                                  |
|--------------------------------------------------------------------------------------------------|-------------------------------------|--------------------------------------|--------------------------------|----------------------------------|------------------------------------------------------------------------------------------------------------------------------------------------------------|
| Rolfe Canal<br>NDT and Lakeside Eng. (1995)                                                      | Atlantic salmon                     | 300                                  | 24-hour<br>testing             | NR                               | Strobe lights were tested as part of an integrated downstream passage system that was concluded to be ineffective in the configurations evaluated.         |
| Fort Halifax<br>ECS and Lakeside Eng. (1994)                                                     | alewife                             | 120                                  | day, dusk                      | NR                               | No identifiable response was exhibited by outmigrating alewife based on limited visual observations of fish movement near the strobe light.                |
| York Haven<br>Martin et al. (1991)<br>EPRI (1990, 1992b)<br>SWETS (1994)<br>Martin et al. (1994) | American shad                       | 300                                  | day, night                     |                                  | Passage of Juvenile American shad through a sluiceway adjacent to Unit 1 was greater during periods of strobe light operation than during control periods. |
| McNary Dam<br>Johnson and Ploskey (1998)                                                         | Pacific salmon                      | 150, 200                             | NR                             | NR                               | Strobe light was effective at repelling outmigrating smolts away from the dewatering screens in the juvenile bypass channel.                               |
| Rocky Reach Dam<br>Anderson et al. (1988)                                                        | Chinook<br>salmon,<br>rainbow trout | 78-780                               | day, night                     | NR                               | Strobe lights were tested in several configurations, none of which produced an increase in fish guidance efficiency of submerged traveling screens.        |
| Puntledge Generating Station<br>Benneyfield and Smith (1989)                                     | coho salmon                         | 60                                   | day, night                     | NR                               | A single strobe light used in combination with hanging chains did not reduce the number of coho smolts entering the station's penstocks.                   |
| Hadley Falls<br>EPRI (1990)                                                                      | American shad                       | 300                                  | day                            | NR                               | Strobe lights did not deter American shad adults from entering a branch canal.                                                                             |

| Site and Reference                                                                                              | Target/<br>Abundant<br>Species | Flash Rates<br>Evaluated<br>(fl/min) | Ambient<br>Light<br>Conditions | Turbidity<br>Conditions<br>(NTU) | General Study Conclusions                                                                                                                                                                    |
|-----------------------------------------------------------------------------------------------------------------|--------------------------------|--------------------------------------|--------------------------------|----------------------------------|----------------------------------------------------------------------------------------------------------------------------------------------------------------------------------------------|
| Burbank No. 3 Water Diversion<br>John Easterbrooks (pers. comm.)                                                | Pacific salmon                 | 300                                  | 24-hour<br>testing             | NR                               | Preliminary results indicate strobe lights may be repelling juvenile salmon, but additional testing and analysis is required.                                                                |
| Hiram H. Chittenden Locks<br>Brown (1999)                                                                       | Pacific salmon                 | NR                                   | day                            | NR                               | Outmigrating sockeye salmon smolts were repelled away from a lock-filling culvert.                                                                                                           |
| <b>Cage and Open Water Tests</b>                                                                                |                                |                                      |                                |                                  |                                                                                                                                                                                              |
| Kingsford<br>Winchell et al. (1997)<br>EPRI (1998b)<br>Michaud and Taft (2000)                                  | riverine spp                   | 200-600                              | day, night                     | NR                               | Mixed results. Avoidance most notable for walleye. Lesser responses by yellow perch, largemouth bass, and Northern pike.                                                                     |
| Roza Diversion Dam<br>Amaral et al. (1998)                                                                      | Chinook salmon                 | 300, 450                             | day, dusk,<br>night            | 3.3-6.5                          | Chinook smolts exhibited strong avoidance of strobe light during tests conducted under nighttime conditions, but no avoidance was observed during tests conducted during the day or at dusk. |
| Dworshak Dam<br>Brown (1999)                                                                                    | Kokanee                        | 300, 360, 450                        | day and night                  | NR                               | Kokanee salmon were repelled by strobe light during open water tests. Response distance was shown to be positively correlated with water clarity.                                            |
| Hiram M. Chittenden Locks<br>Ploskey and Johnson (1998)<br>Ploskey et al. (1998a)<br>Johnson et al (2001, 2004) | Pacific salmon                 | 300                                  | day                            | NR                               | Consistent displacement of test fish away from a strobe light was observed with the test cage oriented both horizontally and vertically in the water column.                                 |
| Seton Station<br>McKinley and Patrick (1988)                                                                    | sockeye salmon                 | >200                                 | dusk and<br>night              | NR                               | A floating trap without strobe lights collected 56% more smolts than a trap with strobe lights.                                                                                              |



| Site and Reference                                                | Target/<br>Abundant<br>Species                   | Flash Rates<br>Evaluated<br>(fl/min) | Ambient<br>Light<br>Conditions | Turbidity<br>Conditions<br>(NTU) | General Study Conclusions                                                                                                                                                                 |
|-------------------------------------------------------------------|--------------------------------------------------|--------------------------------------|--------------------------------|----------------------------------|-------------------------------------------------------------------------------------------------------------------------------------------------------------------------------------------|
| Pickering Station<br>Patrick et al. (1988a)<br>EPRI (1989)        | alewife                                          | >200                                 | NR                             | NR                               | Strobe lights were the least effective of three behavioral devices that were tested as fish deterrents at an open water experimental facility.                                            |
| R. H. Saunders<br>Patrick et al. (1982)                           | American eel                                     | 800                                  | dawn, dusk,<br>night           | NR                               | Based on fish ladder collection rates during treatment and control periods, strobe lights were 65– 95% effective at repelling eels from entering the ladder.                              |
| Ludington Pumped-Storage<br>EPRI (1990)                           | freshwater spp                                   | 300                                  | night                          | NR                               | Fish abundance near the test area was significantly lower during periods when the strobe lights were operated compared to periods when they were off.                                     |
| <b>Laboratory Tests</b>                                           |                                                  |                                      |                                |                                  |                                                                                                                                                                                           |
| Saimaa Fisheries Research Station<br>Königson et al. 2002         | whitefish                                        | 180                                  | dark                           | NA                               | Significant differences individual fish responses to strobe in terms of swim speed, direction of movement, and distance from light source.                                                |
| Pacific Northwest National<br>Laboratory<br>Mueller et al. (1999) | Chinook salmon<br>steelhead trout<br>brook trout | 300                                  | NR                             | NR                               | Responses observed during cage tests were categorized as strong for wild fall Chinook salmon and rainbow trout, moderate for hatchery Chinook salmon, and none to slight for brook trout. |
| Ontario Hydro<br>Patrick et al. (1982)                            | American eel                                     | 66, 220, 484,<br>770, 1,090          | night                          | NR                               | Eels demonstrated strong avoidance to all of the flash frequencies tested, with no acclimation observed during prolonged exposure.                                                        |

| Site and Reference                                                                                                    | Target/<br>Abundant<br>Species                                                                 | Flash Rates<br>Evaluated<br>(fl/min) | Ambient<br>Light<br>Conditions          | Turbidity<br>Conditions<br>(NTU) | General Study Conclusions                                                                                                                                                   |
|-----------------------------------------------------------------------------------------------------------------------|------------------------------------------------------------------------------------------------|--------------------------------------|-----------------------------------------|----------------------------------|-----------------------------------------------------------------------------------------------------------------------------------------------------------------------------|
| Lee County Hyacinth Control<br>District<br>John Cassani (pers. comm.)                                                 | grass carp                                                                                     | NR                                   | 24-hour                                 | NR                               | Measurable effects on grass carp behavior were observed during laboratory tests conducted in an indoor tank.                                                                |
| University of Washington<br>Puckett and Anderson (1988)<br>Nemeth (1989)<br>EPRI (1990)<br>Nemeth and Anderson (1992) | coho salmon<br>Chinook salmon<br>steelhead trout<br>Atlantic salmon                            | 300                                  | day, night                              | NR                               | All four species demonstrated some level of avoidance to strobe light. The type of behavioral reactions that were observed varied with ambient light conditions.            |
| University of Iowa<br>EPRI (1990)                                                                                     | gizzard shad<br>hybrid bass<br>largemouth<br>bass<br>sunfish spp<br>walleye<br>channel catfish | 300                                  | day, night<br>(channel<br>catfish only) | NR                               | All species tested, except largemouth bass, demonstrated some level of avoidance to strobe light. Juvenile walleye exhibited the strongest response.                        |
| University of Maryland<br>McInnich and Hocutt (1987)                                                                  | Atlantic<br>menhaden<br>ppot<br>white perch                                                    | 300                                  | indoor<br>lighting                      | 39-138                           | All species tested exhibited some level of avoidance to strobe light. Strength of avoidance varied with turbidity conditions, often increasing at higher turbidity levels.  |
| University of Maryland<br>Stauffer et al. (1983)<br>Sager et al. (2000)                                               | Atlantic<br>menhaden<br>spot<br>white perch                                                    | 300, 600                             | day and night                           | NR                               | All species tested demonstrated avoidance to strobe light. White perch and spot avoidance decreased and menhaden responses appeared to increase at higher water velocities. |
| Marine Biological Unit, Fawley,<br>U.K.<br>Haddingh and Smythe (1997)                                                 | European eel                                                                                   | 600                                  | NR                                      | NR                               | Eels were deflected by strobe lights at operated at two different illumination levels. The deflection rate was greater at the higher illumination level.                    |

| Site and Reference                                     | Target/<br>Abundant<br>Species                                                               | Flash Rates<br>Evaluated<br>(fl/min) | Ambient<br>Light<br>Conditions | Turbidity<br>Conditions<br>(NTU) | General Study Conclusions                                                                                                                                                          |
|--------------------------------------------------------|----------------------------------------------------------------------------------------------|--------------------------------------|--------------------------------|----------------------------------|------------------------------------------------------------------------------------------------------------------------------------------------------------------------------------|
| Ontario Hydro<br>Rodgers (1983)                        | alewife<br>rainbow smelt                                                                     | >200                                 | NR                             | NR                               | Strobe lights used in combination with other behavioral devices (the primary test device was mercury lights) significantly improved the collection efficiency of a Hidrostal pump. |
| San Onofre                                             | Northern<br>anchovy<br>white croaker<br>Pacific sardine                                      | 90                                   | NR                             | light and<br>dark                | White croaker was repelled by the strobe, Pacific sardine may have been attracted, and dark-adapted Northern anchovy showed a mixed reaction (attraction and repulsion)            |
| Grand Coulee Dam<br>Simmons (2002)                     | Kokanee<br>salmon<br>rainbow<br>trout                                                        | 360                                  | NR                             | NR                               | More fish present when lights on, 50% of detections made 22 m away or further. Avoidance behavior observed with lights on.                                                         |
| Lake Oahe<br>Hamel et al (2008)                        | rainbow smelt                                                                                | 450                                  | NR                             | Day and<br>night                 | Strobe lights were effective at deterring rainbow smelt at high water conditions during nighttime hours                                                                            |
| South Dakota State University<br>Richard et al. (2007) | largemouth<br>bass, fathead<br>minnow,channel<br>catfish, yellow<br>perch, Chinook<br>salmon | 86                                   | NR                             | NR                               | All species exhibited avoidance behavior compared to control groups except for fathead minnow.                                                                                     |

## Mercury Lights

Mercury lights have been considered primarily as an attractant device that may improve fish passage and protection by drawing fish to bypass entrances and/or away from intakes. Observed responses to mercury light have varied among species and size classes, with some fish demonstrating avoidance and others attraction. Generally, mercury lights have been evaluated or employed to draw outmigrating salmonid smolts to bypasses.

Mercury light typically has been evaluated as a means to attract fish, but some researchers have examined its ability to repel fish as well. As an attractant, mercury light can be used to direct fish away from intakes and toward bypasses or safe areas. As a deterrent, mercury light can be deployed to repel fish away from hydro projects. Similar to other behavioral technologies, mercury lights have been used as a secondary fish protection measure that enhances the effectiveness of a primary system designed to reduce entrainment. Mercury lights have been evaluated at many hydroelectric projects as means to improve downstream bypass efficiency of outmigrating anadromous fish (e.g., *Alosa* species, Atlantic salmon [*Salmo salar*], and Pacific salmon species). Few applications have been investigated at CWISs, most likely because mercury light has been considered primarily as an attractant and the use of deterrents provides a more efficient means for reducing entrainment and impingement at CWISs.

**Table 13-2**  
**Summary of mercury light testing conducted during field, cage, and laboratory studies**

| Site and Reference                                                     | Target/<br>Abundant<br>Species    | Mercury Light<br>Specifications                  | Ambient Light<br>Conditions | General Study Conclusions                                                                                                                                                                             |
|------------------------------------------------------------------------|-----------------------------------|--------------------------------------------------|-----------------------------|-------------------------------------------------------------------------------------------------------------------------------------------------------------------------------------------------------|
| <b>Cooling Water Intake Field Tests</b>                                |                                   |                                                  |                             |                                                                                                                                                                                                       |
| Bergum Station<br>Haddingh et al. (1988)<br>Haddingh and Smythe (1997) | European eel                      | 2 lights, 2,000W,<br>above water                 | Night                       | Mercury lights were tested in combination with underwater incandescent lights. Estimated deflection rates for the light system were 51 and 25% for yellow and silver eels, respectively.              |
| <b>Hydroelectric/Water Diversion Field Tests</b>                       |                                   |                                                  |                             |                                                                                                                                                                                                       |
| Mattaceunk (Weldon Dam)<br>Great Northern Paper (1995,<br>1998)        | Atlantic<br>salmon                | 50W                                              | 24-hour testing             | The use of the downstream passage system by outmigrating smolts appeared to increase when the surface inlets were backlit with mercury light.                                                         |
| Turners Falls<br>NUSCO (1997)                                          | Atlantic<br>salmon                | 400W, 2 ft above<br>water                        | Night                       | The overhead mercury light appeared to contribute to increased passage of smolts through a sluiceway. The positioning of the light was important to improving bypass efficiency.                      |
| York Haven<br>EPRI (1990, 1992b)                                       | American shad                     | 1988: 2 lights,<br>1,000W<br>1991: 1 light, 250W | Night                       | Mercury lights did not demonstrate a significant or consistent ability to alter the behavior of juvenile American shad.                                                                               |
| Priest Rapids Dam<br>Pock (1988)                                       | American shad                     | Hydro-Products<br>model L2, 2 lights,<br>1,000W  | 24-hour testing             | Mercury lights were deployed at submerged orifices of a fish ladder in attempts to increase adult shad passage.                                                                                       |
| Wapatox<br>EPRI (1990)                                                 | Pacific salmon<br>steelhead trout | Hydro-Products<br>model L2, 2 lights,<br>1,000W  | Night                       | Mercury lights attracted outmigrating smolts to a bypass entrance, but passage through the facility did not increase. Passage rates did increase during transitions between light on and off periods. |

| Site and Reference                                                             | Target/<br>Abundant<br>Species       | Mercury Light<br>Specifications                 | Ambient Light<br>Conditions | General Study Conclusions                                                                                                                                                                                                                                                                                         |
|--------------------------------------------------------------------------------|--------------------------------------|-------------------------------------------------|-----------------------------|-------------------------------------------------------------------------------------------------------------------------------------------------------------------------------------------------------------------------------------------------------------------------------------------------------------------|
| Wanapum<br>(EPRI 1990)                                                         | Pacific salmon<br>steelhead trout    | Hydro-Products<br>model L2, 1,000W              | Night                       | Mercury lights located on the spillway did not increase downstream passage of outmigrating salmonids. However, results from this study were considered inconclusive due to confounding factors associated with test conditions.                                                                                   |
| Hadley Falls<br>LMS (1989)                                                     | American shad<br>blueback<br>herring | Hydro-Products<br>model L2, 4 lights,<br>1,000W | day, night                  | Mercury lights were concluded to be ineffective at attracting fish to a bascule gate for downstream passage.                                                                                                                                                                                                      |
| Poutes Project<br>Larinier and Boyer-Bernard<br>(1992)                         | Atlantic<br>salmon                   | 4 lights, 400W (1),<br>125W (2), 80W (1)        | Night                       | Three to eight times more fish were bypassed during light-on periods compared to light-off periods. Maximum passage was observed more than one half hour after light activation. Illumination duration, light location, and intensity appeared to be important parameters related to mercury light effectiveness. |
| Annapolis Tidal Station<br>McKinley and Patrick (1988)                         | river herring<br>American shad       | NR                                              | Night                       | Adult and juvenile fish demonstrated slight attraction to mercury light.                                                                                                                                                                                                                                          |
| Hell's Gate<br>Toner (1988)                                                    | river herring                        | Positioned at<br>entrance to fish<br>bypass     | Night                       | Attracted alewife to bypass, however no passage of fish was observed                                                                                                                                                                                                                                              |
| Haandrik<br>Haddingh and Smythe (1997)                                         | European eel                         | above water                                     | Night                       | Mercury lights were tested in combination with underwater incandescent lights. The estimated deflection rate for the light was 66%.                                                                                                                                                                               |
| <b>Cage and Open Water Tests</b>                                               |                                      |                                                 |                             |                                                                                                                                                                                                                                                                                                                   |
| Kingsford<br>Winchell et al. (1997)<br>EPRI (1998a)<br>Michaud and Taft (2000) | riverine spp                         | 2 lights, 175W                                  | day, night                  | No responses to mercury light were observed for any of the species that were evaluated during cage tests.                                                                                                                                                                                                         |

| Site and Reference                                                                                                    | Target/<br>Abundant<br>Species                                                                 | Mercury Light<br>Specifications       | Ambient Light<br>Conditions             | General Study Conclusions                                                                                                                                                                                                               |
|-----------------------------------------------------------------------------------------------------------------------|------------------------------------------------------------------------------------------------|---------------------------------------|-----------------------------------------|-----------------------------------------------------------------------------------------------------------------------------------------------------------------------------------------------------------------------------------------|
| Ludington<br>EPRI (1990)                                                                                              | freshwater spp                                                                                 | Hydro-Products<br>model L2, 1,000W    | Night                                   | Fish abundance near the mercury lights was about twice as high when the lights were operated compared to control periods.                                                                                                               |
| <b>Laboratory Tests</b>                                                                                               |                                                                                                |                                       |                                         |                                                                                                                                                                                                                                         |
| University of Washington<br>Puckett and Anderson (1988)<br>Nemeth (1989)<br>EPRI (1990)<br>Nemeth and Anderson (1992) | coho salmon<br>Chinook<br>salmon<br>steelhead<br>trout<br>Atlantic<br>salmon                   | Hydro-Products<br>model L2, 1,000W    | day, night                              | Fish responses to mercury light were varied and inconsistent. Attraction was exhibited by steelhead trout fry and Chinook salmon, which avoided dim mercury light. Chinook salmon and coho salmon avoided full-intensity mercury light. |
| University of Iowa<br>EPRI (1990)                                                                                     | hybrid bass<br>gizzard shad<br>largemouth<br>bass<br>sunfish spp<br>walleye<br>channel catfish | Hydro-Products<br>model L2, 1,000W    | day, night<br>(channel<br>catfish only) | Little or no attraction to mercury light was observed for the species tested. Largemouth bass, channel catfish, and walleye exhibited avoidance reactions.                                                                              |
| Turners Falls<br>NUSCO (1986)                                                                                         | American shad<br>blueback<br>herring                                                           | 250W, with and<br>without blue filter | day, dusk,<br>night                     | Both species were attracted to blue-filtered and unfiltered mercury light. Attraction responses were observed during nighttime hours, but not during daylight hours.                                                                    |
| Ontario Hydro<br>Rodgers (1983)                                                                                       | alewife<br>rainbow smelt                                                                       | 250W with blue<br>plastic filter      | Dark                                    | Mercury light alone and in combination with other behavioral devices significantly improved the ability of a Hidrostral pump to collect fish.                                                                                           |

## Other Light Sources

Other light sources that have been evaluated as behavioral guidance devices include incandescent, fluorescent, overhead sodium vapor, and drop lights. Underwater incandescent lights have been examined as fish attractants and deterrents, and underwater fluorescent and drop lights have been tested as fish deterrents. Overhead sodium lights have been assessed as attractants. Existing station lighting also has been used in attempts to enhance bypass efficiencies. Most testing conducted to date with these types of lights has been done with anadromous salmonids and clupeids and the catadromous European eel (*Anguilla anguilla*).

Incandescent, fluorescent, and sodium vapor lights appear to have some potential to be applied at water intakes as a component of a fish passage or protection system. Underwater incandescent and fluorescent lights have demonstrated an ability to repel European eels, and incandescent lights have elicited avoidance responses from salmonids in some settings. The studies with European eel suggest that underwater incandescent and fluorescent lights may be applicable as a primary system depending on site design and operation and effectiveness goals. Overhead sodium lights have increased bypass efficiencies of Atlantic salmon (*Salmo salar*) smolts and juvenile clupeids, but do not appear to affect the behavior of several riverine fish species. Sodium lights may be considered as a secondary component to a fish passage or protection system based on their ability to attract outmigrating fish to bypasses or safe areas. The results from limited testing of drop lights with juvenile Chinook salmon (*Oncorhynchus tshawytscha*) do not support the use of this type of stimuli as a fish protection technology for salmonids.



**Table 13-3**

**Summary of tests conducted with other types of light sources during field, cage, and laboratory studies**

| Site and Reference                                                                                                  | Target/<br>Abundant<br>Species | Light System Description                                                                                                           | Ambient<br>Light<br>Conditions | General Study Conclusions                                                                                                                                                                              |
|---------------------------------------------------------------------------------------------------------------------|--------------------------------|------------------------------------------------------------------------------------------------------------------------------------|--------------------------------|--------------------------------------------------------------------------------------------------------------------------------------------------------------------------------------------------------|
| <b>Cooling Water Intake Field Tests</b>                                                                             |                                |                                                                                                                                    |                                |                                                                                                                                                                                                        |
| Amer<br>Haddingh and Smythe (1997)                                                                                  | European eel                   | 30 fluorescent lamps located on river bottom 8 m in front of intake                                                                | Night                          | The estimated deflection rates for the fluorescent lights were 62% and 74% for yellow and silver eels, respectively.                                                                                   |
| Bergum<br>Haddingh and Smythe (1997)                                                                                | European eel                   | incandescent lamps (tungsten filament, continuous spectrum) located on river bottom 5 m in front of intake                         | Night                          | The underwater incandescent lights were tested in combination with overhead mercury lights. Estimated deflection rates for the light system were 51% and 25% for yellow and silver eels, respectively. |
| <b>Hydroelectric/Water Diversion Field Tests</b>                                                                    |                                |                                                                                                                                    |                                |                                                                                                                                                                                                        |
| Richard B. Russell<br>Pickens (1992)<br>Ploskey et al. (1995a)<br>Nestler et al. (1995a,b)<br>Nestler et al. (1998) | blueback herring               | Sodium lights located on each bank of the tailrace to attract fish away from the turbine intakes during pumpback operation         | Night                          | Significantly higher densities of fish were found in the illuminated areas of the tailrace.                                                                                                            |
| Mattaceunk (Weldon Dam)<br>Great Northern Paper (1995)<br>Georgia-Pacific Corp. (1989, 1990)                        | Atlantic salmon                | Incandescent lights were used to illuminate the downstream bypass entrance: used in conjunction with strobe light repelling system | Night                          | Increased collection efficiencies of 37% and 82% for mercury light                                                                                                                                     |
| Pejepscot<br>NDT et al. (1997)                                                                                      | <i>Alosa</i> spp               | Backlit weirs with 50 W halide lights, and lit bypass entrance with 500 W quartz floodlights                                       | Night                          | Only 34% of the total emigrating alewives passed through the turbines with the behavioral deterrent system in place                                                                                    |

| Site and Reference                                                            | Target/<br>Abundant<br>Species | Light System Description                                                                                                        | Ambient<br>Light<br>Conditions | General Study Conclusions                                                                                                                                                                                                                                                                                             |
|-------------------------------------------------------------------------------|--------------------------------|---------------------------------------------------------------------------------------------------------------------------------|--------------------------------|-----------------------------------------------------------------------------------------------------------------------------------------------------------------------------------------------------------------------------------------------------------------------------------------------------------------------|
| Rolfe Canal<br>NDT and Lakeside Engineering<br>(1995)                         | Atlantic salmon                | 75W incandescent lights placed over downstream fishway entrance                                                                 | 24-hour testing                | During this study, incandescent lights were evaluated as part of an integrated downstream passage system that also included strobe lights and physical design features. Testing in 1993 and 1994 indicated that the integrated system designs that were evaluated were not effective at increasing bypass efficiency. |
| Dietfurt<br>Haddingh and Smythe (1997)                                        | European eel                   | 79 fluorescent lamps located on river bottom at a 20 degree angle; light array was 110 m long beginning 80 m upstream of intake | night                          | The estimated deflection rate of eels by the fluorescent lamps was 8%.                                                                                                                                                                                                                                                |
| Haandrik<br>Haddingh and Smythe (1997)                                        | European eel                   | 9 incandescent lamps (200W) located on river bottom 4 m in front of intake                                                      |                                | The underwater fluorescent lights were tested in combination with mercury lights. The estimated deflection rate of eels by the combined light system was 66%.                                                                                                                                                         |
| Rocky Reach Dam<br>Anderson et al. (1988)                                     | Pacific salmon                 | incandescent lights located downstream of trash rack and above submerged traveling screen                                       | 24-hour testing                | The backlighting of the trash rack with incandescent lights did not improve fish guidance efficiency of the submerged traveling screens.                                                                                                                                                                              |
| <b>Cage and Open Water Tests</b>                                              |                                |                                                                                                                                 |                                |                                                                                                                                                                                                                                                                                                                       |
| Roza Diversion Dam<br>Amaral et al. (1998)                                    | Chinook salmon                 | Single underwater drop light                                                                                                    | 24-hour testing                | No detectable response in species tested                                                                                                                                                                                                                                                                              |
| Kingsford<br>Winchell et al (1997)<br>EPRI (1998a)<br>Michaud and Taft (2000) | Riverine spp                   | Overhead sodium, underwater mercury lights in a test cage                                                                       | Night                          | No detectable response in species tested                                                                                                                                                                                                                                                                              |

| Site and Reference                                          | Target/<br>Abundant<br>Species | Light System Description                                                                                                   | Ambient<br>Light<br>Conditions | General Study Conclusions                                                                                                                                                                                                                                                                  |
|-------------------------------------------------------------|--------------------------------|----------------------------------------------------------------------------------------------------------------------------|--------------------------------|--------------------------------------------------------------------------------------------------------------------------------------------------------------------------------------------------------------------------------------------------------------------------------------------|
| River Vecht<br>River Regge<br>Hadderingh and Smythe (1997)  | European eel                   | Row of 9, 200 W incandescent lights on the river bottom and 2 (200 W) high pressure mercury lights above the water surface | Night                          | Up to 85% deflection of eel at Regge                                                                                                                                                                                                                                                       |
| <b>Laboratory Tests</b>                                     |                                |                                                                                                                            |                                |                                                                                                                                                                                                                                                                                            |
| San Onofre<br>Jahn and Herbinson (2000)                     | Marine spp                     | 2 and 3 tungsten incandescent lights (also used with strobes) located above test pool                                      | Dark- and light-adapted fish   | Significant attraction to the steady light source was exhibited by dark-adapted fish                                                                                                                                                                                                       |
| KEMA Environmental Services<br>Hadderingh and Smythe (1997) | European eel                   | 200 W continuous spectrum, 36 W incandescent, and strobe light                                                             | Dark                           | Deflection percentages of 57-86 % for three lamp types, no significant difference in deflection was detected between lamp types at low water velocities                                                                                                                                    |
| University of Washington<br>Puckett and Anderson (1988)     | Chinook salmon                 | 200W, 100W, 40W, and 20W lights located above water                                                                        | varied                         | Fish response to stimulus light was dependent on ambient light levels. Maximum attraction to the stimulus light was when its intensity was equal to ambient light intensity. Active avoidance was observed when the intensity of the stimulus light was 100 times ambient light intensity. |

## Case Studies – Strobe Light – CWIS Field Tests

### **Milliken Steam Electric Station**

New York State Electric and Gas Corporation installed a strobe light system at the Milliken Steam Electric Station in response to requests by the New York State Department of Environmental Conservation (NYSDEC) to determine the best technology available to reduce fish entrainment at the station's cooling water intake. An initial study was conducted in 1993 and 1994 to evaluate the effectiveness of the strobe lights as a deterrent (Ichthyological Associates 1994). A request for additional information by NYSDEC prompted a full year of study in 1995 and 1996 (Ichthyological Associates 1997).

Milliken Station is a coal-fired steam electric generating facility located on Cayuga Lake in Lansing, New York. The station has two generating units that are cooled by a once-through circulating water system that uses raw water drawn from Cayuga Lake. The cooling water intake is an open-ended pipe located about 158.5 m (520 ft) from shore at a depth of 12.2 m (40 ft). The pipe is covered with a very coarse bar grating to keep out large foreign objects. Circulating water is supplied by four pumps at a rate of approximately 10.7 m<sup>3</sup>/sec (380 cfs). Since the plant has no traveling water screens, fish entrainment was evaluated during both studies (i.e., 1993–1994 and 1995–1996) using a partial flow netting system deployed in the station's discharge structure. During the 1993–1994 study, sampling was conducted during the last 8 hrs of strobe-on and -off periods that were 48 hrs in length. In 1995 and 1996, sampling was conducted in a 3-week cycle, with the strobes off for 2 weeks and on for 1 week. The net system was sampled at 12-hour intervals. Strobe light effectiveness was determined by statistically comparing entrainment rates of strobe light on and off periods for significant differences.

Entrainment reductions during strobe-on periods varied with species and time of year, with greater entrainment reductions occurring during months when the intake water was cooler. A total of 29 paired strobe-on and strobe-off samples were collected during the 1993–1994 study. Young-of-year and juvenile rainbow smelt (*Osmerus mordax*) were the most abundant fish collected, followed by alewife (*Alosa pseudoharengus*), yellow perch (*Perca flavescens*), and adult rainbow smelt. An overall reduction in fish entrainment of 37% was observed with the strobe lights operating. Additionally, total fish entrainment increased when the strobe lights were operating in July and August.

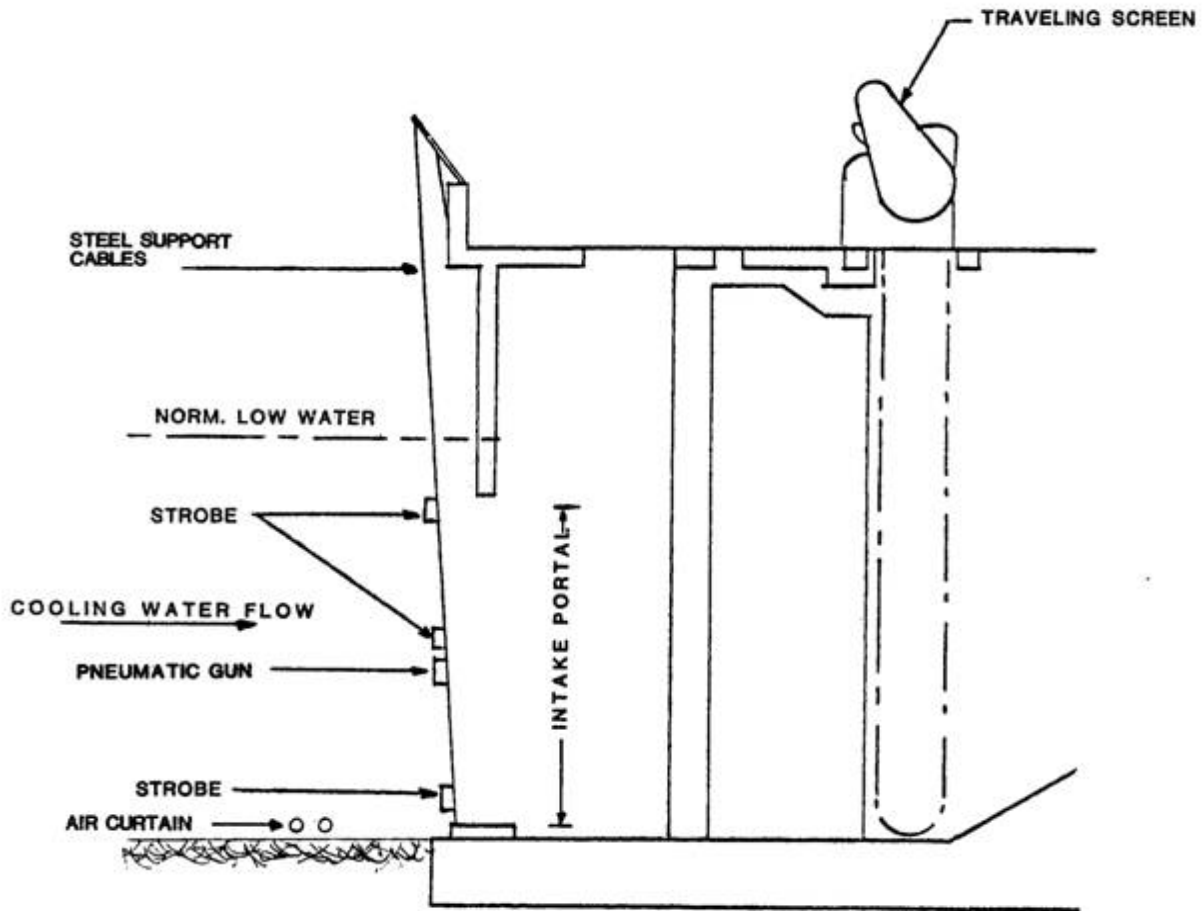
Species entrained during the 1995–1996 study at Milliken included alewife, rainbow smelt, yellow perch, and trout-perch (*Percopsis omiscomaycus*). The most commonly entrained fish was juvenile alewife, which comprised 73% of the total fish collected in the discharge nets. The strobe lights significantly reduced entrainment of adult alewife, white sucker (*Catostomus commersonii*), trout-perch, and slimy sculpin (*Cottus cognatus*), whereas juvenile rainbow smelt entrainment was significantly greater during strobe light periods for the entire study. Behavioral patterns with respect to the strobe lights were distinctly different during certain times of year. From December through mid-July, juvenile alewife, adult alewife, and yellow perch were significantly repelled by the strobe light system. During late summer and autumn, juvenile alewife and yellow perch were significantly attracted by the strobe lights. During October and November, very few species were caught unless the strobe lights were on. Results indicated that 38% more fish were entrained when the strobe lights were operating than when they were off (based on overall catch rate per hour). The overall increase in entrainment during strobe light

operation for the 1995–1996 study was mostly due to the large number of juvenile alewife collected during strobe-on periods in October and November. Based on times of year when certain species and size classes were repelled by the strobe light system, the project owners have requested that strobe light be considered as the BTA for reducing fishery impacts related to entrainment.

### ***Roseton Generating Station***

The Electric Power Research Institute (EPRI), along with several member utilities, sponsored a 4-year field study to evaluate the effectiveness of behavioral barriers at power plant CWISs. Central Hudson Gas & Electric Corporation's (CHGE) Roseton Generating Station on the Hudson River was selected to represent power plants with shoreline riverine intake systems. The effectiveness of strobe lights, a pneumatic air gun (popper), and an air bubble curtain (operated as fish deterrents in combination and singularly) was evaluated at Roseton in 1986 and 1987 (EPRI 1999; LMS 1989; Matousek et al. 1988a, b). Tests conducted with strobe lights are the focus of this review. Evaluations of other behavioral barriers are discussed later.

Roseton Generating Station is a fossil fuel stream electric generating station. Its two units have a total generating capacity of 1,200 MW. The total flow capacity is 41.4 m<sup>3</sup>/sec (1,461 cfs), drawn water from the Hudson River. The intake has eight vertical traveling screens that are mounted to face the river. The behavioral devices were mounted on steel support cables and placed in front of the station intake structure (Figure 13-1).



**Figure 13-1**  
**Roseton intake structure behavioral barriers — section (EPRI 1999)**

The strobe light units evaluated at the Roseton intake were manufactured by EG&G Electro-Optics. The system consisted of an FA-125 power supply and FA-107 flashhead. The strobe lights were operated at 200 flashes per min with a flash duration of 100  $\mu$ s. The strobe light system was located directly in front of the trash racks in front of the 10 intake openings. Three strobe lights were centered and evenly spaced at the top of the portal opening, at the center, and at approximately 0.6 m (2 ft) from the bottom of the eight intake portals.

Spring (March–April) and summer/fall (August–November) were selected as seasonal test periods because long-term fish impingement data suggested these were the times when seasonal impingement peaks occurred. Predominant species impinged during spring were white perch and pumpkinseed. During the summer/fall period, blueback herring (*Alosa aestivalis*), alewife (*Alosa pseudoharengus*), white perch (*Morone americana*), striped bass (*Morone saxatilis*), and bay anchovy (*Anchoa mitchilli*) were the predominantly impinged species.

A series of seven independent treatments were selected at random. During each 24-hour period, one of seven possible behavioral barrier devices or device combinations was tested. The treatment combinations included: pneumatic gun, strobe light, air bubble curtain; pneumatic gun and strobe light; pneumatic gun and air bubble curtain; strobe light and air bubble curtain; and

pneumatic gun, strobe light, and air bubble curtain. The order of treatments within each 7-day period was randomly assigned. Each 24-hr test period was subdivided into four, 6-hour blocks: day, night, dusk, and dawn. A 3-hour control block was paired with each 3-hour test block. The sequence of control and test block was randomly selected. Fish impingement data were collected during treatment tests (behavioral barriers operated) and control tests (behavioral barriers not operated) at 0.5 hour intervals. Water temperature, conductivity, turbidity, and tidal condition were measured at the beginning and end of each 3-hour collection interval. An Effectiveness Index (EI), the percentage reduction in impingement catch attributable to the operation of the behavioral deterrents, was calculated for each device and combination of devices that were tested. The effectiveness index was obtained by subtracting the sum of the fish collected during treatment periods from the sum of fish collected during control periods, divided by the sum of the fish collected during control periods. Statistical analyses were conducted on the effectiveness index measurements to determine significant differences in impingement rates among the treatment and control.

The overall results (both years combined) indicated that no device or combination of devices was effective as a behavioral barrier for all species at all times. Behavioral barrier effectiveness was species-specific and related to time of day. A total of 604 paired treatment and control tests were performed during the 2-year study. Dominant species that were collected from the traveling screens included white perch, bay anchovy, blueback herring, alewives, and American shad (*Alosa sapidissima*). When data from both years and all species are combined, strobe light had the second highest effectiveness index (3.0%). In 1986 and 1987, the overall effectiveness index for strobe light was 22.6 and 3.3%, respectively. In 1986, the effectiveness index of strobe light never exceeded 42.0% for individual species (except for bay anchovy; however, the abundance estimate of bay anchovy during strobe light tests in 1986 was one fish). Strobe light effectiveness indices exceeded 0.0% only for white perch (EI = 29.0%) in 1987. Generally, the effectiveness of strobe light combined with other devices also was low and variable for individual species and for all fish combined. The EI estimates for each device and combination of devices must be viewed with caution, because there was considerable variation in the estimates between years and among species and diel sampling periods. Confidence intervals often broadly overlapped zero, indicating that the observed results could have happened by chance (i.e., were not statistically significant). The observed variability for overall, annual, individual species, and diel estimates may have resulted from inter-annual differences in hydraulic conditions and species abundance and, specifically for all fish combined, physical and behavioral differences among species.

### **Pickering Generating Station**

Experiments were conducted with strobe lights, poppers, and an air-bubble curtain during 1985 and 1986 at the Pickering Generating Station as part of a multi-year research program developed by EPRI to evaluate behavioral systems for fish exclusion. The station is located on Lake Ontario approximately 25 km (15.5 mi) east of Toronto, Canada (Patrick et al. 1988a; Ontario Hydro and LMS 1989). The fish diversion system is 78 m (23 ft) offshore from the surface intake structure. Nine, 0.3 m (1 ft) diameter pilings were arranged in three rows within each of the two identical diversion structures. Support frames, attached to the pilings, had 3.8-cm (1.5-in.) mesh gill nets are stretched across them. Behavioral deterrents were fitted to the west (experimental) structure, while the east structure was used for a control. Six strobes (Super

Freeze Flash Model in 1985 and EG&G Model LS-158 in 1986) were mounted on the experimental test structure at mid-depth and facing offshore. The strobe lights were not synchronized and operated at flash rates greater than 200 flashes per min.

A total of 63 control and experimental tests were conducted randomly in 1985, while a total of 79 control and experimental tests were conducted randomly during 1986. To assess the effectiveness of each behavioral barrier and combination of barriers, sampling of alewife (*Alosa pseudoharengus*) was performed with nets mounted on two test structures (experimental and control) located near the entrance to the cooling water intake channel. Tests were conducted primarily at night when fish movement appeared to be greatest. Alewife catches from 2-hr sampling periods were compared between the experimental and control structures. Additionally, a 15.2 by 1.7 m (49.9 by 5.6 ft) gill net panel (wing net) with 3.2-cm (1.3-in.) mesh was, set at the bottom on the east and west sides of the system in order to identify fish movement on both sides of the experimental and control structures.

Strobe light effectiveness was 56.8% for inshore moving fish and 21.2% for offshore-moving fish. The authors hypothesized that reduced effectiveness for offshore-moving fish was due to diminished flash effect to the rear of the strobes. The effectiveness indices for the strobe light/air bubble combination (both years combined), strobe light/popper combination, and all three devices combined were 67.1, 70.9, and 54.1, respectively. The effectiveness index for the strobe light/air bubble curtain combination may not be accurate because there was substantial variation in effectiveness estimates between the 2 test years (90.1% in 1985 and 39.0% in 1986). Effectiveness varied considerably with depth, ranging from 76% in the surface and mid-water locations to less than 2% near the bottom of the test platform (about 3.7 to 6.1 m [12 to 20 ft] deep). The results from popper and air bubble curtain tests at Pickering are presented in later sections of this report.

## **Case Studies – Strobe Light – Hydroelectric/Water Diversion Field Tests**

### ***Hiram M. Chittenden Locks***

The Chittenden Locks are located at the outlet of Lake Washington in the state of Washington. The locks are a bottleneck to salmon and steelhead (*Oncorhynchus mykiss*) outmigration and may be a contributor to the decline of these species since the 1970s. Emigrants pass the locks through one of three routes: the spillway, the lock gates, or the lock-filling culverts. The culverts are injurious to fish.

Net pen studies of strobe lights at the locks in 1997 showed that yearling coho salmon (*Oncorhynchus kisutch*) and sub-yearling coho and Chinook salmon (*Oncorhynchus tshawytscha*) were strongly repelled (Ploskey and Johnson 2001). In 1998, 10 strobe lights placed around the perimeter of the north-filling culvert showed a 96% reduction in fish density before fills and an 87% decrease during fillings.

In 2001, 36 wall- and bottom-mounted AGL 901 series strobe lights were placed around the filling culverts. From May 3 to June 14, 2002, 101 pairs of strobe-on/strobe-off treatments were conducted during daylight hours. Two down-looking 6-degree split beam Precision Acoustic Systems transducers were used to monitor fish abundance.



Based on the results of 95 valid, paired treatments, the strobe lights were shown to greatly reduce the estimated number of fish entrained into the culvert. In 79% of the treatments, more fish were entrained with the strobe lights off (1,427) than with them on (350) (Johnson et al. 2004).

The strobe lights skewed vertical fish distribution preceding filling events. However, the distribution pattern did not differ much during filling events. The authors suggest that fish response to strobe lights is site-specific and that, where fish are to be repelled under continuous flow conditions, the flow may override the potential repelling effects of the lights.

### ***White Rapids Hydroelectric Project***

Field tests were conducted at the White Rapids Hydroelectric Project to evaluate the ability of strobe light and acoustic signals to repel fish away from a turbine intake (EPRI 1998a, b; Michaud and Taft 2000). The White Rapids Project is located on the Menominee River, which borders Wisconsin and the upper peninsula of Michigan. The project has three Francis turbines. Units 1 and 3 are rated at 3 MW each, with discharge rates of 43.7 m<sup>3</sup>/sec (1,543.3 cfs), and Unit 2 is rated at 2 MW, with a discharge of 25.8 m<sup>3</sup>/sec (911.1 cfs). Based on the results from cage tests conducted at the Kingsford Project (discussed previously), strobe lights and several distinct acoustic signals were selected for evaluation during intake tests conducted at White Rapids. The behavioral deterrents were mounted on two steel frames that were deployed over the trash racks of the two intake bays of Unit 1. Twenty-four strobe lights operated at 300 flashes per min were deployed at the Unit 1 intake. Effectiveness was measured by comparing entrainment numbers during treatment and control periods. Entrained fish were collected in full-flow tailrace nets that sampled the two discharge bays of Unit 1. The field evaluation was conducted during three test periods in July, September, and October of 1997. The following four test conditions were evaluated during the field evaluation: (1) strobe lights on; (2) acoustic system on; (3) both lights and sound on; and (4) control (no devices operating). An air bubble curtain also was evaluated during the October test period.

A wide variety of species were collected in the Unit 1 tailrace nets during the three sample periods. The majority of the fish were young-of-the-year, with mean lengths ranging from 45.5 to 85.3 mm (1.8 to 3.4 in.). There were no significant differences in entrainment numbers between strobe light and control periods for any species, family, or size group analyzed, or for all fish combined, during any of the three sample periods. The statistical analysis of the collection data accounted for diel differences in entrainment rates, which typically were greater during evening hours. Based on these results, it was concluded that strobe lights are not applicable to projects that are similar to White Rapids with respect to project design and fish species occurrence.

### ***Burbank 3 Intake Channel***

Strobe lights were evaluated as a means to reduce entrainment of juvenile Chinook salmon (*Oncorhynchus tshawytscha*) into the Burbank 3 intake channel located on the Columbia River (Brown 1999). A strobe light barrier system was installed at a highway overpass and was designed to exclude Chinook salmon from entering Casey Pond, to which water is diverted. To evaluate the effectiveness of the strobe light barrier, estimates of catch per unit efforts from electrofishing surveys conducted upstream and downstream of the barrier were compared. Preliminary results indicated that the light barrier might have reduced the number of salmon

entering Casey Pond through the intake channel (Brown 1999). Technical problems that may have impacted barrier effectiveness occurred during initial sampling events. Also, environmental conditions (e.g., water temperature) that influence fish behavior are being considered as potential factors that may reduce strobe light effectiveness at this site.

### **McNary Dam**

Strobe lights and infrasound were evaluated for their potential for redistributing migrant yearling and sub-yearling salmonids away from dewatering screens in the McNary Dam Juvenile Bypass System (Johnson and Ploskey 1998). McNary Dam is a low head, river-run hydroelectric facility located on the Columbia River in Umatilla, Oregon, approximately 322 km (200.1 mi) upriver from Portland, Oregon.

Three separate strobe light applications were tested. For the initial spring application, one strobe head (Flash Technologies AGL Series) was installed in mid-channel at the top of the screen panels and aimed toward the screen wall. Two strobe heads were deployed later in the spring and were affixed on the screen wall at 4.3 and 7.3 m (14.1 and 24.0 ft) up-channel from the downstream edge of the side-dewatering screens. For both the spring tests, the strobe heads were operated at an intensity of 400 watts and at a flash rate of 100 flashes per min (fpm; April) or 200 fpm (May). For the summer tests, two strobe heads were installed behind the dewatering screens 7.3 and 11 m (24.0 and 36 ft) up-channel, respectively, from the downstream edge of the side-dewatering screens. A flash rate of 400 fpm and a light intensity of 400 watts were employed for the summer tests. Strobe light performance was evaluated by comparing the difference in mean counts of smolts near the side-dewatering screen during hourly strobe on and off treatments ( $n=18$ ). High resolution underwater cameras were used to monitor distribution and counts of smolts during behavioral device tests.

The effectiveness of the strobe lights was evaluated by observing behavioral changes in smolts passing through areas that were back lit by the strobe flashes. Over 95% of all smolts from spring and summer strobe tests exhibited behavior modified from the normal behavior observed by underwater cameras during control periods. Ninety percent of smolts during spring treatments avoided strobe lights by turning downstream and/or toward the wall opposite of the dewatering screens. In summer tests, 80% of smolts avoided lights by turning downstream and/or toward the wall opposite the screens. The location of the strobe lights was important for successful application. Lights located on or behind the screens flashed light into the left eye of smolts that were backing down the channel. This usually resulted in avoidance of the screens. The authors propose that lights located mid-channel flashed smolts from a tail aspect and may have been an ambiguous stimulus. Factors including limited visibility (due to high water and turbidity during the 1997 tests) and a skewed lateral distribution of fish toward the east wall opposite side dewatering screens during both test and control treatments provided inconclusive results from underwater camera counts.

### **Mattaceunk Hydroelectric Project**

Strobe lights have been evaluated as a means to divert Atlantic salmon (*Salmon salar*) smolts and kelts (post-spawned adults) away from turbine intakes and into bypasses at the Mattaceunk Hydroelectric Project (FERC No. 2520) on the Penobscot River in Maine (Georgia-Pacific Corporation 1989, 1990; Great Northern Paper 1995; Brown 1997). The Mattaceunk Project

(also referred to as Weldon Dam) has four turbine intakes with surface bypasses located at the intakes to Units 3 and 4 (the two units closest to the shoreline). The bypasses are integral with the trash racks and measure approximately 1.2 by 2.0 m (3.9 by 6.6 ft). The design flow for each bypass is about 2 m<sup>3</sup>/sec (70.6 cfs) at normal pond elevation. The bypasses are covered with bars spaced 30 cm (11.8 in.) apart. The remaining trash rack sections on the turbine intakes have bar racks with 2.5 cm (1.0 in.) clear spacing to a depth of 4.9 m (16.1 ft). Fish that enter the surface bypasses are directed around the dam through a series of rectangular collection chambers and into a 1.1 m (3.6 ft) diameter pipe. At the terminus of the pipe is a monitoring facility.

Studies conducted since 1987 have assessed several configurations of strobe light arrays with varying levels of success in diverting smolts and kelts to the surface bypasses. Radio telemetry, the bypass monitoring facility, and underwater video have been used to determine the numbers of fish passing the project either through the downstream passage system or through the turbines. Hatchery-reared Atlantic salmon smolts and kelts were radio tagged and marked prior to their release upstream of Weldon Dam. Routes of passage of radio tagged fish would be monitored by scanning receivers. Additional wild and hatchery smolts were marked and released to supplement efficiency data. All the fish passing through the downstream bypass could be tallied at the monitoring facility.

The collection efficiency of the downstream passage facility for hatchery Atlantic salmon smolts was 59% in 1993 and 45% in 1994. For Atlantic salmon kelts, collection efficiency was either 73 or 82% (due to possible fish escape) in 1993. Additional strobe lights were installed before 1995 because evidence revealed that Atlantic salmon were continuing to enter turbine intakes 3 and 4 below the area of illumination created by a single flashhead. The strobe lights were positioned to provide Units 1 and 2 with complete light field coverage and Units 3 and 4 with coverage over the lower half of their intakes. The upper halves of the Unit 3 and 4 intakes, where the bypasses were located, are not illuminated with strobe light.

Results of studies using radio-tagged smolts in 1995 demonstrated that 15% of released fish that were entrained passed through Units 1 and 2 (18% less than during the 1994 study), and 85% went through Units 3 and 4 (an increase of 18% from the 1994 study) (Bernier 1995; Brown 1997). In 1997, 20% of entrained radio-tagged fish passed through Units 1 and 2 and 80% through Units 3 and 4 (Brown and Bernier 1997). Despite the apparent ability of the strobe lights to divert smolts away from the intakes of Units 1 and 2 and into the intakes of Units 3 and 4, fish capture efficiency did not increase. Radiotag data and underwater video indicated that an increased number of smolts were directed to the entrance of the bypass outlets. However, there was an apparent reluctance for fish to enter the bypasses. The percent of released fish that have used the surface bypasses has never exceeded 59%. The lowest bypass efficiency was observed during the most recent study in 1997, when 41% of released fish were recovered in the surface bypasses. The collection efficiency of the downstream passage facility for hatchery Atlantic salmon smolts was 52% in 1995 and 41% in 1997. For Atlantic salmon kelts, collection efficiency was 76% in 1995. No smolt studies were conducted in 1996, and no kelt studies were conducted in 1994, 1996, or 1997 due to high water levels.

### ***Four Mile Hydroelectric Project***

Field studies conducted at the Four Mile Hydroelectric Project in Michigan examined the ability of strobe lights to reduce entrainment of potamodromous fish (GLEC 1994; McCauley et al.

1996). The Four Mile Project is a run-of-the-river facility with three horizontal Francis turbines. Each unit has a generating capacity of 600 kW and a discharge volume of 13.5 m<sup>3</sup>/sec (476.7 cfs). In an effort to reduce fish passage through the turbines at this project, an evaluation of the strobe lights and an air bubble curtain was conducted by comparing fish entrainment rates for behavioral device operation periods and control periods. Full-flow tailrace netting was used to collect entrained fish during the behavioral device evaluations. The initial evaluation conducted in 1994 evaluated "off the shelf" strobe lights. The results from this study indicated that the behavioral devices had minimal or no impacts on entrainment rates. In 1995, a redesigned strobe light system was installed and evaluated. Test days were divided into four, 6-hr time periods: dawn, day, dusk, and night. Each time period was divided into 1.5-hr sample intervals. All three treatments (strobe light alone, air bubble curtain alone, and strobe/air combined) and the control were randomly tested during each 6-hr period. Twelve strobe lights were positioned near the six rectangular openings to the forebay. The strobe light was visible 4.5 to 9 m (14.8 to 29.5 ft) in front of the intake. To produce the air bubble curtain, three parallel perforated air lines were placed 15 cm (5.9 in.) apart along the bottom of the reservoir, 2 m (6.6 ft) in front of the forebay. The lines released air that formed a 30-cm (11.8-in.) wide curtain of air that extended from the bottom of the reservoir to the surface.

The 1995 study conducted with the redesigned strobe light system demonstrated significant reductions in entrainment for some fish species. The combination of strobe and air bubble barrier reduced turbine passage by an average of 81% for all species combined. The strobe lights operated alone reduced total turbine passage by an average of 77%, and the air treatment alone produced an average reduction in total entrainment of 43%. Mean percent reductions for bullhead (*Ameiurus* spp.), the most abundant species, were 82, 80, and 69% for strobe/air combined, strobe light alone, and air bubble curtain alone, respectively. For the second most abundant species, golden shiner (*Notemigonus crysoleucas*), mean percent reductions were 94, 86, and 55% for strobe/air, strobe light alone, and air bubble curtain, respectively. The reductions in entrainment for bullhead species were statistically significant. However, reductions for golden shiner were not statistically significant, most likely due to low numbers of shiners passing through the turbines. The effectiveness of the behavioral barriers used during this study was found to be dependent on the time of day. Dramatic reductions in the number of fish (primarily bullhead and shiners) passed during dawn, dusk, and nighttime periods were observed. None of the treatments were effective during the day time period with any of the species collected.

### **Rolfe Canal Hydroelectric Project**

A series of downstream fish passage studies, beginning in 1992, was conducted at the Rolfe Canal Hydroelectric Project as part of a FERC license article requiring upstream and downstream passage facilities for anadromous fish (Lakeside Engineering 1996). Strobe lights and incandescent lights were installed prior to the 1993 study, and modifications were made to the fishway entrance to improve attraction and passage efficiency of Atlantic salmon (*Salmo salar*) smolts. Bypass efficiency tests using strobe lights included only the 1993 and 1994 studies and will be the only studies we discuss here. We will report other technologies used in conjunction with strobe lights at the Rolfe Canal Project in the Hybrid Barrier chapter.

The Rolfe Canal Project is located on the Contocook River in New Hampshire. The project consists of a concrete spillway, a 1,220 m (4,003 ft) long canal, a 293 m (961.3 ft) long penstock,

a powerhouse, and a 366 m (1200.8 ft) long tailrace canal. The penstock intake structure has two 3.7 m (12.1 ft) wide, 12.2 m (40 ft) deep bar racks with 8.9 cm (3.5 in.) clear spacing. A bar rack with 1.9 cm (3/4 in.) clear spacing is located upstream of the wider-spaced racks and extends to a depth of 4.3 m (14.1 ft) at normal canal level. The project has a single horizontal Kaplan turbine with a runner diameter of 3 m (9.8 ft) and a rotational speed of 150 rpm. The hydraulic capacity of the unit is 58 m<sup>3</sup>/sec (2,048.3 cfs) at minimum net head. The downstream facilities consist of the narrow-spaced bar racks and a bypass facility with an entrance located next to the penstock intake.

Strobe lights were used as a means to repel fish away from the penstock intake and guide fish toward the bypass entrance. The strobes were operated at 300 flashes per min. For the 1993 study, a strobe light was installed on each side of the outer trash rack (1.9 cm [3/4 in.] spacing) at 2/3rds depth. A light-proof cover was installed over the trash rack frame to improve the day time effectiveness of the strobes. The strobe lights were lowered to the bottom of the trash rack in the 1994 study to discourage smolts from sounding under the trash rack.

A mark-recapture technique was employed to determine the percentage of fish using the bypass facility during the 1993 studies. A total of 861 marked and 450 unmarked fish were released into the canal upstream of the intake structure from April 29 to June 11. Recapture rates for all releases were low (ranging from 1.0% to 53.6%). Based on the 1993 study results, it was concluded that none of the fishway modifications or additional measures were successful in achieving an acceptable level of bypass efficiency.

Similar to the 1993 study, the effectiveness of the downstream passage facilities was evaluated by releasing lots of hatchery smolts into the power canal and collecting fish that passed through the fishway. Each lot consisted of about 520 fish, most of which were released into the canal. Any remaining fish were held as controls. The first lot of fish was released 914 m (2,998.7 ft) upstream of the penstock intake. Due to a low recapture rate of these fish, the next three lots were released within 152 m (498.7 ft) of the intake. The settings for the various fishway components (e.g., entrance weir setting) and diversion devices (e.g., barrier net in place, lights on or off) varied for each release group. The percent of released fish recaptured in the downstream fishway ranged from 0.4% for Lot 1 to 8.7% for Lot 4. Based on the low recapture rates, it was concluded that the effects of the different fishway components (entrance weir level, strobe and incandescent lights, barrier net) could not be reliably assessed. However, the low recapture rates indicate that the bypass modifications and additional measures employed for the 1994 study, in the various configurations that they were tested, were ineffective at increasing the efficiency of the downstream passage facilities at the Rolfe Canal penstock intake.

### ***Fort Halifax Hydroelectric Station***

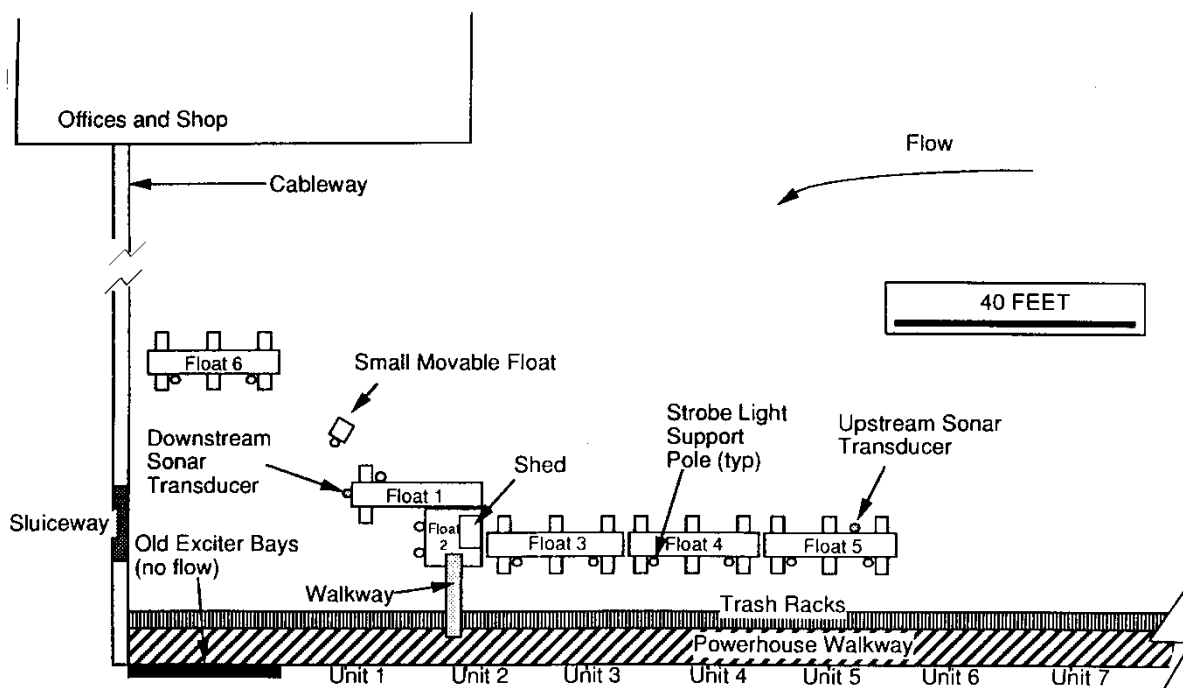
Strobe light was evaluated as part of the downstream fish passage facilities at the Fort Halifax Hydroelectric Project (Environmental Consulting Services and Lakeside Engineering 1994). Two sound devices also were examined during this study, and we discuss results from their evaluation in the chapter on sound technologies. The Fort Halifax Project is the lowermost dam on the Sebasticook River in Maine. The project has two vertical turbines, each with a maximum intake flow of 24.1 m<sup>3</sup>/sec (851.1 cfs). The average approach velocity to the trash rack is 0.50 m/sec (1.64 ft/sec), with both turbines at full capacity. Intake flows approach the trash rack at angle greater than 45 degrees, and the bar spacing is 3.8 cm (1.5 in.) clear. The bypass consists

of an automated floating crest weir entrance and a flume that carries fish to a tailrace pool. In lieu of the installation of bar racks with 2.5-cm (1.0-in) clear spacing, existing trash racks were modified with a 1.2 m (3.9 ft) plywood overlay. The downstream passage facilities are designed for use by Atlantic salmon (*Salmo salar*) and American shad (*Alosa sapidissima*) as well as alewife (*Alosa pseudoharengus*). Mark-recapture techniques were used to evaluate the ability of a strobe light to repel or guide juvenile alewife away from the turbine intakes and toward the bypass entrance. The strobe light was a 1,000 candela-seconds source operated at 120 flashes per min. Based on the estimated bypass efficiencies, the strobe light did not appear to affect alewife behavior. Limited water visibility (i.e., high turbidity) was cited as a possible reason for a lack of response to strobe light.

### **York Haven Hydroelectric Project**

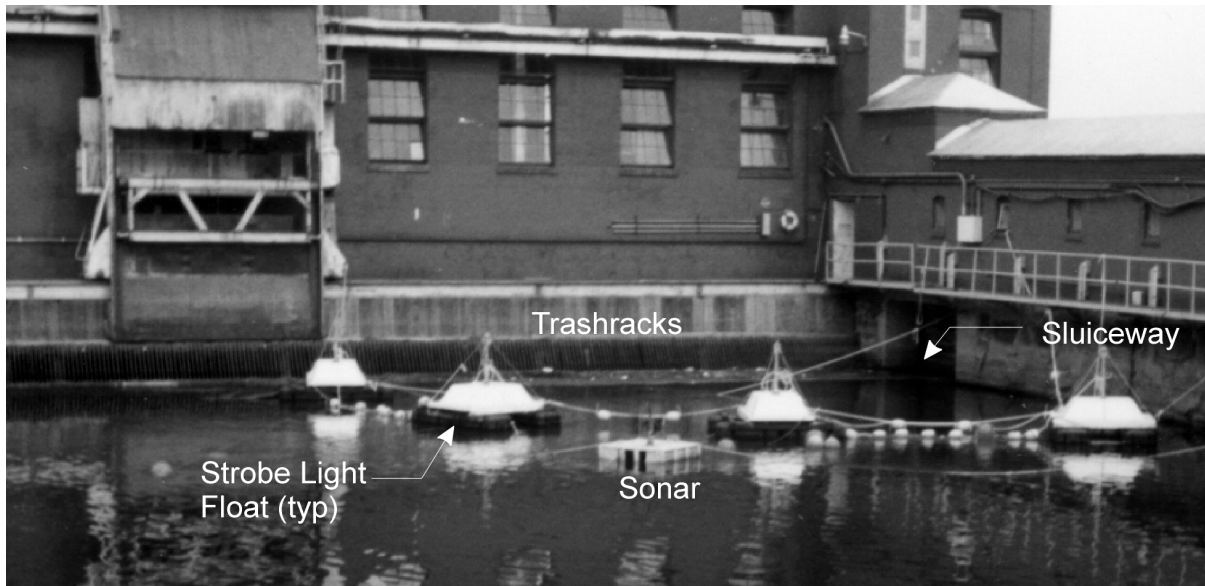
Juvenile American shad (*Alosa sapidissima*) demonstrated a strong avoidance response to strobe lights during field tests conducted over a 5-year period at the York Haven Hydroelectric Project (EPRI 1990, 1992b; Martin et al. 1991; Martin and Sullivan 1992). The project is located on the Susquehanna River 15 miles south of Harrisburg, Pennsylvania. It consists of a 2,438 m (7,998.7 ft) dam and powerhouse containing six Kaplan turbines and 14 Francis turbines, each with a capacity of approximately 22.7 m<sup>3</sup>/sec (801.6 cfs). Strobe lights were evaluated to determine their ability to divert juvenile shad away from the plant turbines and into an existing trash sluiceway.

From 1988 to 1991, various arrangements of strobe lights were evaluated (flash rate = 300 flashes per min). In all years, the lights were attached to various floats located in front of the intake trash racks upstream of an ice/trash sluiceway (considered a safe bypass route) at which the lights were aimed. The configuration tested in 1991 appears on Figure 13-2.



**Figure 13-2**  
**1991 forebay and float positions, York Haven Hydroelectric Project (Taft et al. 2001)**

This configuration was highly effective in preventing fish passage into Units 1 through 6 and repelling them to the sluiceway bypass. However, the float system created maintenance problems. Therefore, the system was redesigned for 1992 tests. Four newly designed floats were arranged in an arc around the sluiceway opening, with none positioned at the trash racks (Figure 13-3). Two Flash Technology strobe lights were fastened to steel poles under each of the floats at depths of 0.9 and 2.7 m (3 and 8.9 ft).



**Figure 13-3**  
**1992 forebay and float positions, York Haven Hydroelectric Project (Taft et al 2001)**

The strobe light system was evaluated by using scanning sonar and a netting program. The scanning sonar system (WESMAR Model SS390) was used to monitor fish responses and behavior to the strobe lights. Tailrace nets were used to quantify the passage of fish through the turbines and sluciceway. All tests were performed from dusk until early morning, when the juvenile shad were actively migrating.

The strobe lights strongly and consistently repelled fish in 1988 tests. When the strobes were turned on, large aggregations of fish were observed to pass immediately through the sluciceway. The effect of the lights did not diminish over time (up to 1 hr). The illuminated area remained void of fish as long as the strobes were in operation. When the strobes were turned off, fish avoiding the lights moved quickly into the previously lit area. Data collected during 1989 and 1990 were limited by the occurrence of major floods, which resulted in most outmigrants passing over the dam. During these years, however, hydroacoustic observations and limited net sampling indicated that the light array effectively deterred fish that were approaching the turbine intakes. In 1991, the new strobe light configuration was evaluated. Favorable flow conditions allowed extensive sampling to be conducted, including netting in the tailrace and at the slucic gate. During 156 paired tests (strobe light and control), juvenile American shad passage through the sluciceway averaged 1,712 fish for strobe light tests and 38 fish for control tests (estimates adjusted for volume of flow sampled). Passage through the turbine also increased during strobe light tests. However, the increase only represented about 6% of the fish passed out the sluciceway. The increase in turbine passage during strobe light illumination demonstrates the need to determine relationships between behavioral fish bypass systems and site-specific hydraulics in order to maximize bypass efficiency.

### ***Hadley Falls Hydroelectric Project***

In 1987, EPRI sponsored studies examining the use of strobe lights to repel adult American shad (*Alosa sapidissima*) at the Hadley Falls Hydroelectric Project located on the Connecticut River in Holyoke, Massachusetts (EPRI 1990). The project's powerhouse is located on the west side of



the dam. The dam also diverts water into a canal system that supplies flow to another hydroelectric project and various other water users. Adult and juvenile American shad encounter the Hadley Falls project during outmigrations in the spring and fall, respectively. Once in the canal system, fish can follow one of two passage routes: downstream to the Boatlock Hydro Station (where a fish bypass and return pipe transports them back to the river) or down a branch canal (where they become trapped).

The strobe lights were modified Fish Avoidance Xenon System (FAXS) designed by EG&G. All the strobe heads were synchronized and operated at a flash rate of 300 flashes per min (fpm). Strobe lights were suspended into the water from a canal bridge in attempts to repel adult shad away from a first level canal branch. The effectiveness of the strobe lights in excluding shad from the branch canal was evaluated by video monitoring. Strobes were sequenced on and off on an hourly basis for 8 hrs per day, and monitoring efforts were conducted during both on and off conditions. Video recordings were made during the first 15 min of each test period and for several min at 0.5-hour intervals throughout the test period.

The tests indicated that the strobe lights were ineffective in repelling adult shad during daylight hours, which was when most fish movement occurred. Although the point sources (flash tubes) were highly visible to the human eye, the level of illumination was minor compared to daylight illumination. This was true even when the photometer sensor was aimed directly at the strobe lights. Fish were observed moving in schools that reacted to the bridge's shadow by maintaining position upstream of the shadow. The addition of strobe lights had no apparent effect on the fish's behavior as they approached the bridge. Fish were observed swimming within a few inches of the light even though the light was flashing directly toward their eyes. The lack of reaction indicated that strobe light as an indirect or direct (point source) stimulus had no effect on adult American shad during daylight hours.

### **Puntledge Generating Station**

A study was conducted by B. C. Hydro to evaluate the effectiveness of strobe lights, an underwater hammer, and a hanging chain system in deterring coho salmon (*Oncorhynchus kisutch*) smolts from the penstock intakes at the Puntledge Generating Station (Benneyfield and Smith 1989). Puntledge Station is a hydroelectric project located about 6.5 km (4 mi) downstream of Comox Lake, Vancouver, B.C. Water enters the generating station through a 100 m (328 ft) long, 15 to 20 m (49.2 to 65.6 ft) wide, 3 to 5 m (9.8 to 16.4 ft) deep approach channel. The channel carries a minimum flow of 2.8 m<sup>3</sup>/sec (98.8 cfs). Fish passage is provided by a 2.4 m (7.9 ft) wide stoplog spillway. Total turbine discharges during the test periods were 20.4 and 27.2 m<sup>3</sup>/sec (709.8 and 960.6 cfs).

A single underwater strobe light was positioned beneath the upstream end of the logboom near the concrete wall and pointed diagonally downstream to illuminate the chain curtain. The strobe light operated at approximately 1-second intervals. All the behavioral devices were on for two nights and off for two nights each week and left on during weekends throughout the periods of fish migration. Strobe lights were not operated during daylight hours except on weekends.

The effectiveness of the behavioral devices (all devices were operated in unison) was evaluated by comparing the catch distribution of smolts in the bypass versus the catch distribution in the tailrace when the devices were on and off. Trapping of smolts was conducted simultaneously in the bypass and in the tailrace. Two 15 cm (5.9 in.) wide Wolf traps were used in the bypass, and

a single steel-mesh cone trap was used in the tailrace. From May 12 to June 23, 1989, both migration routes were systematically trapped. All of the catches were sorted by species, examined for marks, and counted. Additionally, a subsample of the smolt catches was measured for fork lengths. The Wolf traps sampled 14.3% of the bypass spill width. Combined catches from both Wolf traps were used in a regression formula to estimate the total number of smolts that moved through the bypass during the study period. Estimates for the number of smolts passing through the penstock were arrived at similarly. Tailrace trap numbers were recorded and entered into formulas to adjust for weekend catches, water discharge rates, and trap efficiency. A two sample t-test was used to compare the on and off sample observations.

The behavioral devices did not significantly increase the proportion of coho salmon smolts using the bypass. Results of the calculated t-value of 0.81 suggested that the difference in mean catches between on and off nights could have occurred by chance. Observations of coho smolt behavior did indicate reaction to one or more of the behavioral devices. The devices, however, failed to provide sufficient behavioral cues to divert or guide a significant number of fish away from the penstock and into the bypass. The authors suggest that better results may have been attained at sites with slower, near-laminar flow.

### **Rocky Reach Dam**

The Chelan County Public Utility District No. 1 funded a 2-year study to investigate the potential for strobe lights to improve fish guidance efficiencies (FGE) of a prototype submersible traveling screen (STS) at Rocky Reach Dam on the Columbia River (Anderson et al. 1988). From 1986 to 1987, strobe lights, incandescent lights, and a deflector projecting outward from the trash rack were deployed. The following discussion presents results of the strobe light evaluation at Rocky Reach Dam.

Two strobe lights were attached to the trash rack and aimed upward into the water column during spring of 1986 in an attempt to drive fish upward where they would be intercepted by the STS. Field tests and model studies suggested that fish could move horizontally away from the strobe beam, and therefore the configuration of the strobes (located on the trash rack and facing into the forebay) would not significantly improve guidance. In summer of 1986, the strobe lights were moved to provide illumination to the trash rack from below. It was postulated that fish moving down the trash rack face would encounter the strobe lights and escape through the trash rack and into the STS. Field tests indicated that lighting the trash rack did not improve passage of fish. A bar screen deflector was mounted immediately below the level of the STS, and strobe lights were attached just above the bar screen. The purpose of the deflector was to “box-in” fish between the strobe and the deflector so that passage through the trash rack was the only available escape route. The deflector strategy was proven ineffective in field tests. Fish were able to move around the front of the deflector with or without the strobe light operating.

### **Seton Creek**

Strobe lights, pneumatic poppers, and a hammer device were tested as means to divert downstream migrating sockeye salmon (*Oncorhynchus nerka*) smolts away from turbine intakes at the Seton Hydroelectric Station. The station is located on Seton Creek near the town of Lillooet in British Columbia (McKinley et al 1987; McKinley and Patrick 1988). The strobe lights used were Superfreeze flash unsynchronized units, operated at 200 flashes per min.

Tests were performed by sampling downstream migrants with fyke nets attached to two platforms (i.e., experimental and control) anchored in the forebay about 350 m (1148.3 ft) upstream of the project intake. The behavioral devices were mounted on one of the platforms (experimental platform) near the top of the water column. Testing was performed at night when peak diel migration occurs. Five to 10 paired control and experimental tests were conducted for each behavioral device. Additionally, 12 control replicates, with no behavior devices operating on either test structure, were conducted to correct any bias in fish distribution between the two platforms. The effectiveness of the behavioral devices was assessed by comparing the fyke net catches from each platform during 0.5-hour test periods. The difference in the number of fish caught between the control and experimental nets (effectiveness index) was calculated for each device.

The percent effectiveness for the strobe lights was approximately 56%. A lower catch of sockeye in the experimental structure was observed in all tests except the last one, during which it was noticed that one of the strobe lights was giving off less light, thereby reducing the area of influence. Earlier laboratory tests had indicated that the effectiveness of strobe lights would be reduced significantly at high water velocities, especially at velocities approaching about 1.0 m/sec (3.3 ft/sec). The maximum sustained swimming speed for sockeye smolts was estimated at about 0.4 m/sec (1.3 ft/sec). Because water velocities were relatively high at Seton, it was believed that the smolts would have to respond to the strobe lights within a certain distance if they were to avoid net capture. The area of influence of the strobe light was estimated to be approximately 4.9 m (16.1 ft). The results from popper and hammer tests are presented in the sound barrier section.

## **Case Studies – Strobe Light – Cage and Open Water Tests**

### ***Dworshak Dam***

Strobe lights have been evaluated as a potential means to reduce entrainment of Kokanee salmon (*Oncorhynchus nerka*) at Dworshak Dam in Idaho (Brown 1999). Exploratory tests were conducted at night at nearby lakes and in the project impoundment in 1997 and 1998 during spring, summer, and winter months. The tests consisted of anchoring a boat in an area of the study site with high densities of Kokanee salmon and then lowering four strobe lights to a predetermined depth. The lights (Flash Technologies, Franklin, TN) were pointed horizontally at 90 degree angles and turned on and off. Flash rates of 300, 360, and 400 flashes per min were evaluated and intensities at a Secchi depth of 9.5 m (31.2 ft) were between 59 and 56 lux at the 360 and 450 flash rates, respectively. Another boat equipped with a Simrad EY500 split-beam echosounder made multiple passes in the area of the light and recorded any change in the distribution of Kokanee when the lights were alternated on and off. Fish densities were estimated (EP500 software, v. 4.5 or 5.2) within 30 m (98.4 ft) in horizontally and 5 m (16.4 ft) vertically of the flash heads in all trials except during testing in October 1998 when they were estimated within 70 m (229.7 ft) horizontally of the flash heads. The experimental design was the same for all three tests with variations in strobe light depth, duration of the on/off intervals, and strobe light flash rates. The results of all trials are summarized in (Table 13-4).

The initial tests with Kokanee and strobe lights were conducted during the spring of 1997. In May, the strobe lights were tested at a depth of about 12 m (39.4 ft) in water that was 22 m (72.2 ft) deep, with flash rate 450 flashes per min. During treatment, fish mean fish distance and

density dropped significantly from 7 m (23 ft) and 814 fish/ha, respectively, during controls, to 30 m (98.4 ft) and 138 fish/ha. Similarly, during testing in June, mean fish distance and density dropped from 7 m (23 ft) and 1,200 fish/ha to 30 m (98.4 ft) and 235 fish/ha with the lights operating at 300 flashes per min. Additional tests were performed with the boat drifting to simulate fish approaching the lights. The distribution of Kokanee appeared unaffected when the lights were off. Fish were observed moving rapidly away from the strobe lights when they were activated. All flash rates tested appeared to be equally effective at repelling Kokanee to an average distance of 30.5 m (100 ft) for the entire duration (about 45 min) of each test. Summer tests were conducted in August 1997, with a flash rate of 360 flashes per min. The boat from which the strobe lights were deployed was kept in the same place the entire night to determine if salmon would habituate to the strobe over an extended period of time. During this test, Kokanee were repelled by the strobe light for the duration of the test (approximately 6 hrs) and maintained an average distance of about 40 m (131 ft) from the lights. Fish densities also decreased significantly by 94% within 30 m (98.4 ft) of the lights.

Testing conducted in Lake Pend Oreille yielded very similar results (Table 13-4). During June testing, a flash rate of 300 flashes per min yielded significant decreases in fish distance and density from 4 m (13.1 ft) and 751 fish/ha to 45 m (147.6 ft) and 120 fish/ha. A flash rate of 450 resulted in significant decreases in fish distance and density from 6m (19.7 ft) and 548 fish/ha to 45 m (147.6 ft) and 154 fish/ha.

The winter tests were conducted in February 1998 to determine the effectiveness of strobe lights during periods when water clarity was high (Secchi depth of 17.5 m [57.4 ft]) and at locations where depths exceeded 183 m (600.4 ft). During the winter tests, the strobe lights (360 flashes per min) were lowered to a depth of 20.1 m (65.9 ft). Kokanee were a mean distance of 14 m (45.9 ft) from the strobe lights when they were turned off. Fish moved an average of 120 m (393.7 ft) away from the strobe lights after they were activated. The densities of Kokanee within 30 m (98.4 ft) of the strobe lights decreased significantly from an average of 372 fish/ha to 4 fish/ha. The much greater avoidance distance that was observed during the winter tests (about three times as far as observed during spring and summer tests) was attributed to the higher level of water clarity. Tests conducted in Lake Pend Oreille in October of 1998 yielded similar results although the Secchi depth was substantially lower (9.9 m [32.5 ft]) (Table 13-4). Based on the results of these tests, the potential for effective application of strobe lights at Dworshak Dam was considered promising, but additional testing, including an on-site evaluation, was recommended.

Results of a recent onsite evaluation conducted by the Idaho Department of Fish and Game demonstrated the effectiveness of the lights in decreasing densities of fish near the turbine intakes.

**Table 13-4**  
**Strobe light testing results for Spirit Lake and Lake Pend Oreille. P-values are for paired t-tests between treatment and control groups (Maiolie et al. 2001).**

| Lake                     | Date     | Secchi depth (m) | Flash rate (flashes /min) | Mean distance to first group of fish (m) |      |         | Reduction in fish density within 30m |                    |
|--------------------------|----------|------------------|---------------------------|------------------------------------------|------|---------|--------------------------------------|--------------------|
|                          |          |                  |                           | control                                  | test | P-value | Percent                              | P-value            |
| Spirit Lake              | 5/29/97  | 3.7              | 450                       | 7                                        | 39   | 0.036   | 83                                   | 0.023              |
| Spirit Lake              | 6/17/97  | -                | 300                       | 7                                        | 30   | 0.006   | 80                                   | 0.071              |
| Spirit Lake <sup>a</sup> | 7/30/97  | 4.7              | 360                       | 1                                        | 40   | < 0.001 | 94                                   | 0.002              |
| Lake Pend Oreille        | 6/18/97  | 2.75             | 300                       | 4                                        | 45   | < 0.001 | 84                                   | 0.098              |
| Lake Pend Oreille        | 6/18/97  | 2.75             | 450                       | 6                                        | 45   | 0.009   | 72                                   | 0.084              |
| Lake Pend Oreille        | 2/25/98  | 17.5             | 360                       | 14                                       | 120  | 0.026   | 98                                   | 0.021              |
| Lake Pend Oreille        | 10/29/98 | 9.9              | 300,360,450 <sup>b</sup>  | 0                                        | 136  | 0.004   | 100                                  | 0.015 <sup>c</sup> |

<sup>a</sup> Testing July 30, was the habituation experiment

<sup>b</sup> Analysis of three flash rates were combined

<sup>c</sup> Kokanee density estimates were analyzed within 70m of the lights

### ***Kingsford Hydroelectric Project***

The response of potamodromous fishes to types of behavioral guidance devices was evaluated during cage tests conducted at the Kingsford Hydroelectric Project on the Menominee River in Wisconsin (Winchell et al. 1997; EPRI 1998a, b; Michaud and Taft 2000). The cage tests were designed to determine whether stimuli produced by the selected devices could elicit avoidance or attraction responses that may be useful for designing or enhancing the effectiveness of fish passage and protection systems. As part of this study, the ability of strobe lights to elicit avoidance reactions during cage tests and to reduce entrainment at a turbine intake was evaluated. The field evaluation was conducted at the White Rapids Hydroelectric Project and is discussed above in the section describing strobe light field evaluations. Similarly, we discuss tests with the other behavioral devices that were evaluated in their respective sections.

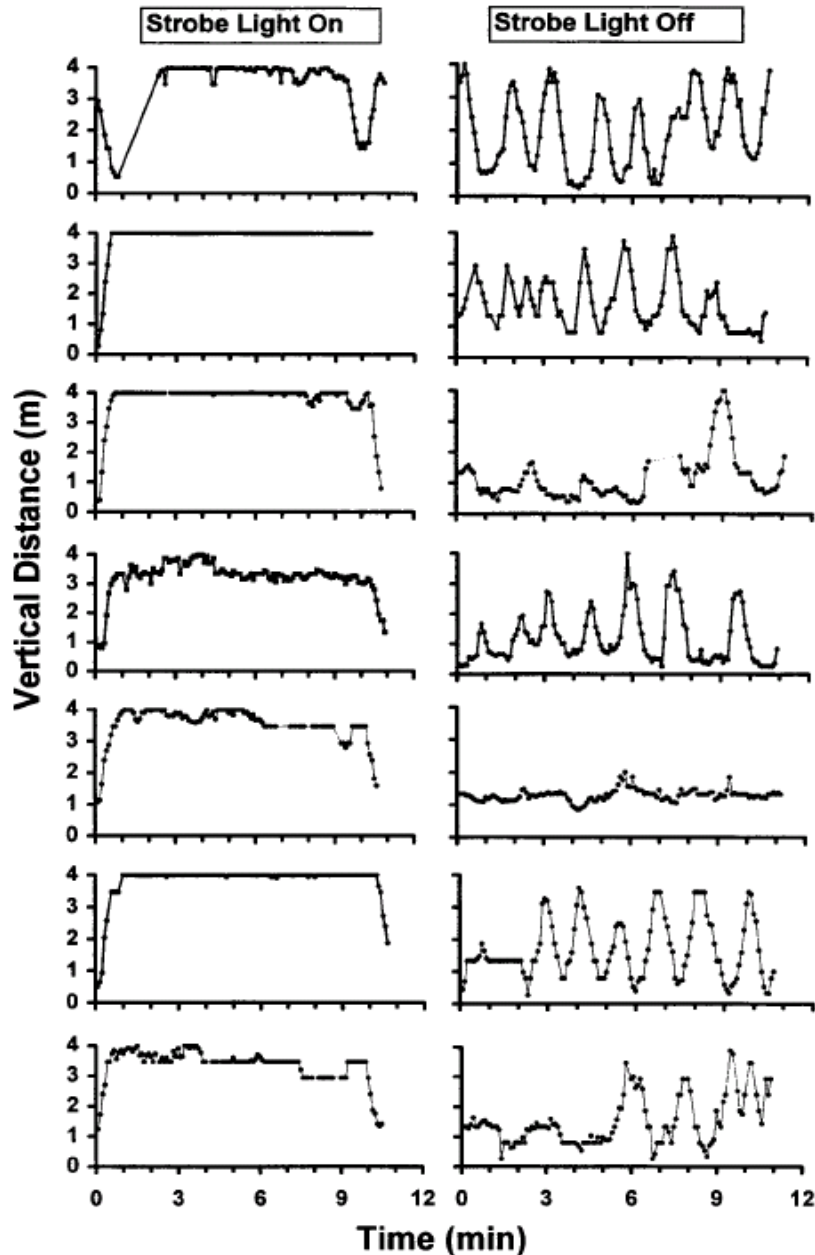
Fish response to strobe light was assessed by placing a group of fish in the test cage (3.6 by 1 by 1 m [11.8 by 3.3 by 3.3 ft]) and alternating the operation of single lights located at either end of the cage. Each light was activated for periods up to 10 min in duration. An underwater video system was used to observe fish during each test. Qualitative observations describing fish response were made based on spatial and temporal movements (i.e., distance, direction, and speed of movement). The species that were evaluated with strobe lights included walleye (*Sander vitreus*), largemouth bass (*Micropterus salmoides*), smallmouth bass (*Micropterus dolomieu*), yellow perch (*Perca flavescens*), sunfish species (Centrarchids), and rainbow trout (*Oncorhynchus mykiss*). The target size range for test specimens was 50 to 250 mm (2.0 to 9.8 in.) in length. Test fish were collected from the Menominee River and from private hatchery sources. During the cage tests conducted at Kingsford, strobe lights elicited consistent avoidance

reactions from walleye, and weak reactions from largemouth bass and yellow perch. No responses to strobe light were observed for smallmouth bass, sunfish species, and rainbow trout. Based on observations for the three species that exhibited avoidance, strobe lights were selected to be evaluated during the field study conducted at the White Rapids Project, as we discuss above.

### **Hiram M. Chittenden Locks**

Cage tests were conducted at the Chittenden Locks to evaluate the response of juvenile salmonids to strobe light and sound stimuli (Ploskey and Johnson 1998, 2001; Ploskey et al. 1998a; Johnson et al 2001). Experiments were conducted to evaluate the effectiveness of these devices in eliciting vertical avoidance in juvenile salmonids. Tests with sound devices are discussed later. The studies were conducted using a 4 m (13.1 ft) long, 1.5 m (4.9 ft) diameter net pen with 3.2-mm (0.1-in.) mesh webbing. Four underwater cameras were mounted at 1 m (3.3 ft) intervals on the net pen frame to monitor fish behavior. The strobe lights used in this study consisted of three flash heads mounted together on a single frame. Each light was operated at 300 flashes per min. Tests were conducted with the long axis of the cage oriented vertically and horizontally. The lights were located below the pen for vertical tests and within 1.5 m (4.9 ft) of one end of the pen during horizontal tests. All tests were conducted during daylight hours due to difficulty of monitoring with the video system at night. Groups of 10 to 25 fish were placed into the net pen approximately 30 to 60 min before a test was initiated. Each camera's field of view was divided into two parts, producing a total of eight zones. The number of fish located in each zone was used to assess fish movement during each test by calculating a center of school position at specified time intervals.

Avoidance responses were observed during most of the strobe light tests. The maximum range of effectiveness for the strobe light was estimated at approximately 4.5 m (14.8 ft). If the ambient light intensity was weak (i.e., greater contrast between strobe light and ambient light), the strobe light had a greater effectiveness distance. The frequency of vertical avoidance by juvenile salmonids was 90 to 100% when the strobe lights were located within 0.5 m (1.6 ft) of the bottom of the pen. Avoidance frequency decreased to about 45% for yearling coho salmon (*Oncorhynchus kisutch*) when the pen was moved 2.5 m (8.2 ft) away from the lights. When the lights were moved 4.5 to 6.5 m (14.8 to 21.3 ft) away, avoidance frequency decreased to about 19%. Thirty-second reactance tests demonstrated initial avoidance responses, whereas 10-min exposures revealed prolonged changes in movement patterns. During these 10-min trials, the fish that received the strobe light treatment moved quickly at least 3 m (9.8 ft) away from the light source and eventually to the uppermost portion of the net pen furthest from the light until the lights were shut off and the fish slowly began to redistribute. We present results of the 10-min trials in Figure 13-4. Observations indicated that horizontal and 45 degree upward aiming of strobe lights into the bottom 1 m (3.3 ft) of the pen were effective in eliciting strong and consistent avoidance.



**Figure 13-4**  
**Vertical distance of yearling coho salmon above strobe lights that were flashing five times/sec for 0 to 10 min (left) and the same distances for schools during control treatments without strobe light (right) (Ploskey and Johnson 2001).**

An open water study produced similar results in May 1998 when 10 strobe light flash heads at flash rates of 300 flashes per second were installed around the perimeter and in the front of the north-filling culvert. (Johnson et al 2001). This study compared paired strobelight on/off densities of juvenile salmon before and during fill event at the lock during daylight hours. Fish densities at the depth of the culvert (8 to 13 m [26.2 to 32.8 ft]) decreased by 96% with the strobe lights on during daylight hours.

This experimental strobe light system was consequently accepted as a permanent installation based on its effectiveness in deterring the passage of juvenile salmonids. Since then, an evaluation of the strobe light system was conducted and concluded that, on average, significantly less fish were entrained during periods when the lights were on at all strata ( $P = <0.0001$ ). It was not determined whether or not strobe lights enhanced passage at the locks by vertically displacing juvenile salmon, however tests showed that fish were displaced closer to the surface when strobe lights were used (Johnson et al. 2004).

### **Roza Diversion Dam**

The response of Chinook salmon (*Oncorhynchus tshawytscha*) smolts to strobe lights was evaluated during cage tests conducted at the Roza Diversion Dam screening facilities located on the Yakima River in Washington (Amaral et al. 1998). The tests were conducted to determine if strobe lights could be used to guide outmigrating smolts to the screening facilities and increase bypass use. A drop light and an infrasound generator also were evaluated during this study. We describe the response of Chinook salmon to these devices later. In addition to Chinook salmon, a limited series of tests were conducted with Northern pikeminnow (*Ptychocheilus oregonensis*) and smallmouth bass (*Micropterus dolomieu*) to assess the potential of strobe lights to be used as a predator deterrent.

Behavioral deterrent tests at Roza were conducted using a cage (3.7 by 0.9 by 0.9 m [12.1 by 3 by 3 ft]) suspended from a floating test facility (modified pontoon boat). A test channel (0.4 by 3.4 by 0.6 m [1.3 by 11.2 by 2 ft]) was constructed within the cage and was supplied with a continuous flow of water that created velocities of about 0.12 m/sec (0.4 ft/sec) during most tests. Both the cage and the test channel were enclosed with transparent plastic sheeting. An underwater video system with four cameras was used to monitor fish behavior in the test channel during each test. Strobe lights were mounted on aluminum poles and deployed at either end of the test facility deck (i.e., upstream and downstream of the cage). Three different light positions relative to the ends of the cage were evaluated. The strobe light flash heads were aimed perpendicular to the length-wise axis of the test channel. This positioning created a light gradient across the length of the test channel that varied in intensity depending on ambient light levels and the position of the lights relative to the end of the cage.

Two series of tests were conducted with strobe lights and Chinook salmon. The first series consisted of exposing fish to strobe light from one end of the cage for 1 to 2 min periods. The second series consisted of alternating the operation of the lights at either end of the cage for 10-min exposure periods during a total test period of 60 min (i.e., each light was operated for three 10-min periods). Flash rates of 300 and 450 flashes per min were evaluated during both test series. A group of 12 to 25 Chinook salmon smolts were used in each test. Northern pikeminnow also were evaluated during two 60-min nighttime tests with four fish (one test was conducted at 300 flashes per min and the other at 450), and four smallmouth bass were evaluated during one test at 450 flashes per min.

Fish responses were evaluated by calculating a center of school position at 15-second intervals during 1-min exposure tests, at 30-second intervals during 2-min tests, and at 1-min intervals during 60-min exposure tests. Tests were conducted during daytime, dusk, and nighttime hours to assess fish responses under different ambient light conditions. Supplemental lighting was used within the test cage during 1-min nighttime tests to allow for video observations. This



lighting was not used during 2-min and 60-min tests, during which observations of fish movement were made by a biologist positioned above the cage (this also prevented the use of control periods because fish could not be seen without any lights on). Fish movement during 1-min exposure tests was compared to movement during control periods. Fish movements during 2-min and 60-min tests were assessed for speed and distance of movement away from the active light source based on the center of school position over time.

Chinook salmon did not demonstrate any obvious or consistent avoidance responses to strobe light during the 1-min test periods. Movement of fish during treatment periods generally was similar to movements observed during control periods. Fish responses during the 2-min exposure tests (which were conducted at night without supplemental lighting) also were limited, but there was some movement away from the active light source. Movement of fish during these tests was constrained by their location at the beginning of a test. During the 60-min tests conducted at night, Chinook salmon strongly and consistently avoided the strobe lights. Avoidance reactions were characterized by movement from the end of the cage nearest the active source to the end furthest away, where fish remained until the light source was switched to the end at which fish were holding position. This pattern of behavior was observed during the entire duration of nighttime tests, although the strength of response when the upstream light was activated appeared to diminish with time. No discernible reactions to strobe light were noted during 60-min daytime and dusk tests. A lack of response during these periods of the day most likely was due to little or no contrast between ambient light and the strobe light within the test channel.

Northern pikeminnow exhibited moderate directional responses to 300 flashes per min but not 450 flashes per min. Smallmouth bass reactions were similar to those observed for Chinook salmon during 60-min tests. Strong directional avoidance to the end of the cage opposite the active source was observed each time light operation was switched. Because a limited number of tests with only a few fish were conducted with Northern pikeminnow and smallmouth bass, it was recommended that further studies be conducted to verify the observations that were made during this study.

### ***Ludington Pumped Storage***

The effects of strobe lights, mercury lights, and hammers on fish densities were examined at the Ludington Pumped Storage Project (EPRI 1990). The devices were tested as potential means to reduce entrainment of Lake Michigan fish into the reservoir during pumpback operation. The project is located near Ludington, Michigan, on the east shore of Lake Michigan. The powerhouse consists of six turbine units that also serve as pumpback units. Flows are 1,869 m<sup>3</sup>/sec (66,003.1 cfs) during pumpback operation.

A boat, secured by piles on both side, served as a work platform in the test zone. Four strobe lights were used, two set at a depth of 1.5 m (4.9 ft) and two set at a depth of 4.6 m (15.1 ft), with 9.1 m (29.9 ft) of horizontal distance between the pairs. The strobe lights used were modified Fish Avoidance Xenon System (FAXS) designed by EG&G. The 1,000 W mercury lights were set in a similar configuration. Ontario Hydro supplied the two hammers that were tested.

Over a 4-month period in 1987, the behavioral devices were evaluated during nighttime hours near one of the project's intake jetties (where fish were known to congregate). Each test lasted for 2 hrs. During this time, three test conditions or two test conditions and one control were

evaluated. When the plant was operating in pumpback mode, fish abundance was monitored using hydroacoustic techniques during periods with and without test devices operating. Gill net sampling was performed during testing to identify fish species in the test area.

Statistical procedures were used to determine the influence of the test devices and test periods on fish abundance. For all three of the months in which strobe lights were tested, fish abundance was lower during periods of strobe light illumination than periods with the lights off. When the monthly data are combined, the average fish abundance during strobe light illumination periods [abundance index (A.I.) = 2.99] was significantly less than the average abundance for the control condition (A.I. = 8.03). The mercury lights achieved a consistent attraction of resident fish. The average abundance of fish present with the mercury lights on (A.I. = 15.38) was nearly twice that of the control condition (A.I. = 8.03). The difference in fish abundance between test and control conditions was significantly different in all test months. The results of hammer tests were considered inconclusive. Overall, the mean abundance of fish in the test area with the hammers operating was less than the control condition. However, the results for individual months were variable. In 1 month, the mean abundance of fish was greater when the hammers were operating (EPRI 1990).

### **R. H. Saunders Generating Station**

American eels (*Anguilla rostrata*) showed strong avoidance response to strobe lights in both laboratory tests and in the field (Patrick et al. 1982). Field test with strobe lights were conducted at the entrance to an eel ladder at the R. H. Saunders Generating Station. The station is located on the St. Lawrence River in Cornwall, Ontario. The study objective was to determine the feasibility of using strobe lights to exclude migrating eels from the turbine housing at R. H. Saunders GS.

American eels were netted at the R. H. Saunders GS dam in August of 1979 and placed in 2.4 m (7.9 ft) circular diameter tanks for the laboratory investigations. The eels used ranged in length from 30 to 50 cm (11.8 to 19.7 in.). The tank was divided into three areas approximately 1.5 m<sup>2</sup> (16.1 ft<sup>2</sup>) each. One of the chambers was illuminated with white strobe light (1 watt flash power, Tandy Electronics). Varying degrees of light intensities and flash rates (66, 220, 484, 748, and 1,090 flashes per min) were tested. Nine replicates, using 15 eels per replicate, were conducted at 5- and 15-min test intervals. After each test interval, the number of eels in each chamber was recorded, and observations on the distribution of eels (relative to the light source) were noted. A closed circuit TV was used to monitor eels during laboratory tests to determine if eels were exhibiting behavioral adaptations to the strobe light.

Field studies used the existing eel ladder, with modifications, as a collection facility. A collecting trough was installed at the terminus of the ladder. The trough led into a collection tank with sizing chambers. Strobe lights were located at the entrance to the eel ladder. Two strobe light intensities were tested. One configuration included three strobes: two small (1-watt flash power, Tandy Electronics) strobes and one large (40 watt flash power, York Instruments) strobe pointed toward the entrance of the ladder. The alternative configuration employed an additional strobe light (York Instruments) at the mouth of the eel ladder. The number of eels passing over the ladder was recorded for both test (strobe lights operating) and control (strobe lights off) conditions.

Results for the laboratory tests reported that the mean number of eels was at least six times lower in the illuminated chamber for all strobe frequencies. There was no statistical difference between strobe frequencies ( $F_{2,49}=0.87$ ,  $p>0.05$ ), which suggested that the rate of strobe flashing did not influence eel avoidance. Behavioral monitoring in laboratory tests indicated that eels showed a strong avoidance to the lit area. There was a 94% reduction in the total number of eels in the lit zone compared to chamber occupancy under uniform light conditions.

Field studies resulted in high variability in numbers of eels collected in control and test periods. The lower intensity strobe configuration produced reductions of 66.9, 77.0, and 65.3% in eel numbers passing the ladder (relative to control numbers). The higher intensity tests achieved reductions of 89.1 and 91.6% in eel ladder passage. The experimental test number of eels collected was statistically lower than that recorded from the control tests.

### **Lake Oahe**

A field study was conducted to test the effectiveness of strobe lights deterring rainbow smelt (*Osmerus mordax*) in Lake Oahe, South Dakota (Hamel et al. 2008). Lake Oahe is the largest of four main stem, multi-purpose reservoirs on the Missouri River in South Dakota. By volume, it is the 14th largest reservoir in the world. The Oahe Dam has seven intake structures that transport water through 7.3-m (24-ft) diameter, steel-line concrete tunnels to the powerhouse that consist of seven Francis turbines. Intakes are located at mid-depth of the dam to facilitate deep-water releases.

Night testing of strobe lights was conducted from June through September of 2004 and 2005. During 2004 tests, a model AGL-FH 901 flash-head consisting of four horizontal lights positioned at 90 degrees was used. It flashed at 450 flashes per min and 2,634 lumens per flash. A model AGL-FH 920 omni-directional flash-head was used during 2005 testing. This model has a single vertical light tube that is able to produce flashes in a full 360 degrees range. It flashed at 360 flashes per min and 6,585 lumens per flash.

From 1996-1999, the South Dakota Department of Game, Fish, and Parks conducted hydroacoustic and mid-water trawl surveys in lower Lake Oahe. This survey was dominated by rainbow smelt (*Osmerus mordax*), comprising 90-100% of the trawl catches. From this data, fish were assumed to be rainbow smelt during the 2004-2005 study. The strobes were deployed in the lacustrine zone at the thermocline (i.e., the area of high rainbow smelt abundance during the period of testing). An anchored boat with a hydraulic winch was used to lower and raise the strobes out of the water. Behavior and abundance of rainbow trout was monitored using a separate boat, equipped with radar, GPS, and hydroacoustic equipment. To determine the position to deploy the device, hydroacoustic transects were undertaken to determine locations and depths of high abundances. Once deployed, behavior and abundances were tracked using a hydroacoustic transducer housed in a buoyant PVC platform. The platform was positioned and re-positioned every 5 min along a transect starting at 3 m (9.8 ft) out from the strobes and increasing at intervals 3 m (9.8 ft) to maximum distance of 21 m (68.9 ft). Data collection was first conducted with the strobes turned off to serve as a control. After the control data collection, the strobes were activated and the transect was repeated. Once completing the transect, the hydroacoustic transducer was turned off while the strobes remained on. After 4 hrs, the transducer was reactivated and the transect was repeated. The EchoShape post processing program was used to estimate rainbow smelt densities and determine difference between time

and depth interval. The effectiveness of the strobes was evaluated by comparing densities at exposures of 1 hr and 4 hrs to control densities.

Testing of the FH-901 model was conducted on September 7th and 16th in 2004. On September 7th, water depth was 45 m (147.6 ft) and the depth of the thermocline was 25 m (82 ft). The strobe was deployed at 24 m (78.7 ft), the maximum allowable depth because of the length of the cord. Density of rainbow smelt in the area was approximately 5 fish/100 m<sup>3</sup>. There was a significant decrease densities by 51% (P<0.01) after 1 hr and 46% after 4 hrs (P<0.01) compared to control densities. Upon activation, a significantly higher portion of fish densities (89% (P<0.01)) occupied the bottom strata below the strobe light. Because of such high densities at the bottom strata, there was no significant difference between time intervals and depth (P= 0.87).

On September 16th, water depth and strobe depth were comparable to the prior test and rainbow smelt density was 4 fish/100 m<sup>3</sup>. The 4 hr waiting period after the transect was not carried out because of inclement weather. There was a significant decrease of densities by 78% (P <0.01) after 1 hr compared to the control group. Densities were significantly larger at the bottom strata (P<0.01) upon activation. There were significant differences between time intervals and depth (P=0.02).

In 2005, tests for the FH-920 were conducted on August 11, 15; and September 24. On August 11, water depth was 44 m (144.4 ft) and the thermocline depth was 21 m (68.9 ft). Densities of rainbow smelt in the area were 7 fish/100 m<sup>3</sup>. Before activation, fish densities were significantly higher at the top strata than the bottom (P<0.01). Once activated, densities at the bottom strata were greater than the top strata (P<0.01). However, there was no significant difference in densities at the bottom strata between control and treatment fish (P>0.5). It was suggested that fish present at the top strata before activation were deterred beyond the furthest distance of measure. Identical densities were seen after the 4 hr waiting period, suggesting no acclimation behavior. Testing on August 15 was conducted at a similar water depth with fish densities of 5 fish/100 m<sup>3</sup>. Testing during this period produced almost identical results to the previous day of testing.

Testing conducted on September 26th was at water depths of 35 m (115 ft) at fish densities of fish/100 m<sup>3</sup>. Densities between treatments and controls demonstrated a significant shift to the bottom strata (P=0.04). After the 4 hr waiting period, densities significantly increase compared to controls (P<0.01), however the distribution remained greater in the bottom strata.

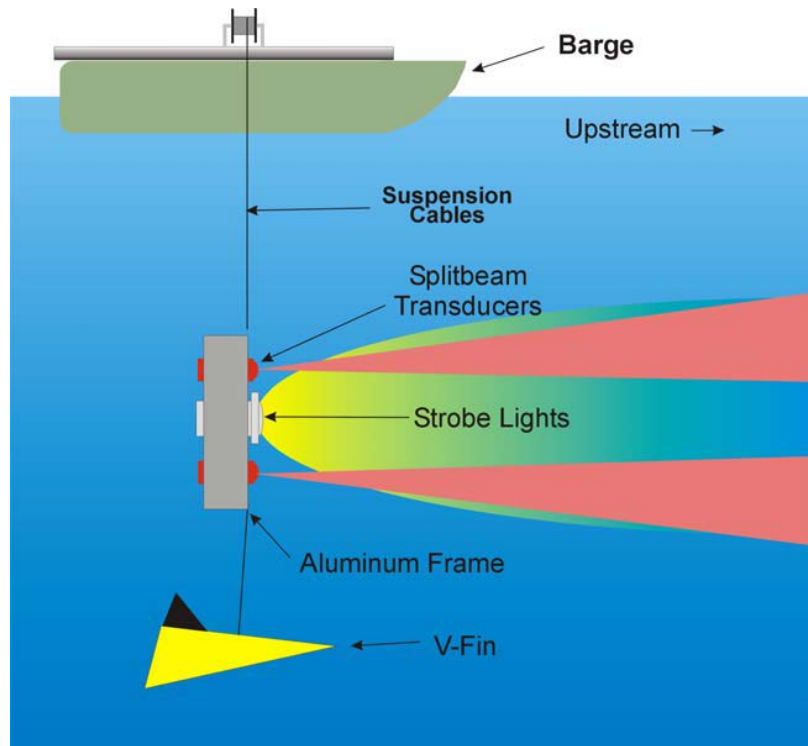
Results collected from this study determined that strobe lights would reduce entrainment of rainbow smelt at high water conditions during nighttime hours. With this being said, not all potential factors effecting success of strobe lights as a deterrent were tested.

### **Grand Coulee Dam**

Grand Coulee Dam is located on the Columbia River, Washington. The dam consists of four power plants and a spillway. Thirty-three generators have a total generating capacity of 6,809 MW. The spill way is 498 m (1,635 ft) long, located in the middle of the dam and consists of 11 spill gates.

Fish distribution and behavioral analyses were conducted to determine the effectiveness of strobe lights at eliciting negative phototactic response by Kokanee (*Oncorhynchus nerka*) and rainbow trout (*Oncorhynchus mykiss*) (Simmons et al. 2002). Testing was conducted at the entrance of

the forebay of the third power plant from June 30 through August 1 2001. Strobes were aimed at a restricted region directly upstream of the barge location. Three strobe lights, each produced a maximum of 20,000 lumens/flash at a flash rate of 360 flashes/min, were mounted on an aluminum frame and deployed from the barge at a depth of approximately 9 m (29.5 ft) (Figure 13-5). Four splitbeam hydroacoustic transducers were used to track fish movements, two directed upward in the water column and two directed downward. Treatment scenarios for fish distribution testing were lights on 24 hrs, lights off 24 hrs, and alternating lights on/off every hour for 24 hrs. A fixed barge was set upstream of the power plant. Fish behavior was observed during 24 hour on/off periods. Swim speed and amount of turning behavior determined avoidance behavior.



**Figure 13-5**  
**Deployment of strobe lights and hydroacoustic transducers from fixed barge (Simmons et al. 2002)**

In comparing 24-hr lights on/off conditions, 19,485 and 15,869 were present with the lights on and off respectively. Fish were more evident in downward looking transducers than upward looking transducers. A total of 15,329 fish were detected during the 1-hr on/off treatments. In general, more fish were detected while lights were on during the 1-hr on/off treatments, but there was no significant trend. As with the 24-hr on/off conditions, more fish were evident by the downward looking transducers. Substantial factors affecting the fish distribution analysis included power plant discharge, distance from lights, and test date.

Behavioral tests demonstrated that fish attempted to avoid the lights within a distance of 14 m (49.5 ft) by swimming across the lighted region or upstream. Swimming behaviors were found to be faster and straighter while the lights were on. These behaviors were more pronounced by medium and large sized fish during night conditions.

Although more fish were present during lights on conditions, 50% of the detections were beyond 22 m (72.2 ft). Behavior evaluations indicate negative phototactic responses to lights. The authors indicate that this is first complex hydroacoustic study conducted at the third power plant forebay of Grand Coulee and recommended a number of modifications and enhancements for a follow-up study. Further studies providing additional data will help merit future strobe light installation.

## **Case Studies – Strobe Light – Laboratory Studies**

### ***Laboratory Study - Saimaa Fisheries Research and Aquaculture Station, Finland***

To evaluate the effect of strobe light on the behavior of whitefish (*Coregonus lavaretus*), field and laboratory experiments were carried out in 1999. The response of whitefish to strobe light had not been previously studied. While most other studies of fish response to strobe light focused on groups of fish, this study examined the responses of individual fish. Fish behavior was characterized by both swimming speed and swimming direction to determine if they exhibit an avoidance response to strobe light and if it is possible to guide fish in a certain direction using strobe light (Königson et al. 2002).

Both the field and laboratory efforts used a bank of three strobe lights (3 by 20 W, 100  $\mu$ s pulse) set to flash independently about three times per second. The field study was conducted during darkness in an 8,000 m<sup>2</sup> (86,111 ft<sup>2</sup>) rectangular net enclosure located at Birkö, an island on the Swedish coast of the Baltic Sea. The maximum depth in the enclosure was 8 m (26.2 ft). Wild whitefish (850 g mean weight) were externally tagged with ultrasonic transmitters and released in the enclosure. The fish were given up to 20 hrs to recover before testing commenced. Three hydrophones were used to triangulate the position of fish in the enclosure and monitor their movement at 30 second intervals. The strobe light device was suspended from a small row boat at 1.5 m (4.9 ft) below the water surface aiming horizontally towards the front of the boat. Prior to activating the strobe light, the boat was moved closer to the tagged fish. After the strobe light was activated, the boat was rotated for 10 seconds to ensure that the fish was subjected to the light. To determine whether the movement of the boat was responsible for the fish's behavior rather than the strobe light, five control trials were conducted in which the boat was maneuvered in the same manner but without activating the strobe light.

The laboratory study was conducted at the Saimaa Fisheries Research and Aquaculture Station in Finland in a 2.5 by 1.4 by 0.5 m (8.2 by 4.6 by 1.6 ft) rectangular tank. The test facility was surrounded by a black tarpaulin to create a darkened environment. The strobe light device was positioned in the middle of the tank on one side in a vertical orientation. A shield was installed over the strobe light device to create a 25-degree wide beam when activated. An infrared lamp illuminated the tank and an infrared sensitive video system was used to monitor fish. Forty-six hatchery reared fish of wild stock (17 to 24 cm [6.7 to 9.4 in.] total length) were separately introduced to the tank and allowed to acclimate for a minimum of 4 hrs before a trial began. Fish movement was monitored for 5 to 10 min before and after the strobe light was activated, and during the 5 to 10 seconds the strobe light was on. To determine if strobe light could be used to guide fish in a certain direction, the stimulus was applied in three different manners: just ahead of, directly at, or directly behind each fish. Any change in swimming direction that resulted was quantified as a turning angle.

Results from the field study showed that swimming speed increased after exposure to strobe light for all nine fish tested (Table 13-5), and the increase was statistically significant. In addition, all fish increased their distance from the strobe light. In contrast, control tests did not result in a change in swimming speed after the boat had maneuvered near the fish.

**Table 13-5**  
**Median swimming speed (v) of experimental fish before and after the strobe light was switched on.**

| Fish | v before light (m/sec) | v after light (m/sec) | Difference (m/sec) |
|------|------------------------|-----------------------|--------------------|
| 1    | 0.11                   | 0.13                  | +0.02              |
| 2    | 0.04                   | 0.09                  | +0.05              |
| 3    | 0.03                   | 0.22                  | +0.19              |
| 4    | 0.04                   | 0.1                   | +0.06              |
| 5    | 0.13                   | 0.24                  | +0.11              |
| 6    | 0.28                   | 0.48                  | +0.20              |
| 7    | 0.07                   | 0.2                   | +0.13              |
| 8    | 0.11                   | 0.12                  | +0.02              |
| 9    | 0.04                   | 0.06                  | +0.02              |

Results from the laboratory study also demonstrated significant differences in swimming speed before and after fish were exposed to strobe light for all three types of light application (Table 13-6). All fish increased their swimming speed after being subjected to the stimulus. The turning angles of fish subjected to strobe light from the side and in front were significantly different than those of undisturbed fish. However, there was no significant difference when light was applied behind the fish. Eight of sixteen fish demonstrated a sudden change in swimming direction when light was applied from the side of the fish. Fifty-four percent of these fish swam away from the light source, while 46% swam toward it. When light was applied in front of the fish, 12 of 15 fish suddenly changed direction. Of these, 57% turned away from the light source while 43% turned toward it. No change in swimming direction was observed when light was applied behind the fish.

**Table 13-6**

Mean swimming speed (v) and standard deviation for experimental fish before and after exposure to light in the different rounds. Significant differences ( $P < 0.05$ ) between swimming speed are indicated by \*\*.

|      | v before light behind (m/sec) | v after light behind (m/sec) | v before light in front (m/sec) | v after light in front (m/sec) | v before light at the side (m/sec) | v after light at the side (m/sec) |
|------|-------------------------------|------------------------------|---------------------------------|--------------------------------|------------------------------------|-----------------------------------|
| Mean | 0.03                          | 0.07                         | 0.05                            | 0.09                           | 0.05                               | 0.09                              |
| S.D. | 0.01                          | 0.04                         | 0.04                            | 0.03                           | 0.02                               | 0.04                              |
| n    | 15                            | 15                           | 15                              | 15                             | 16                                 | 16                                |
| P    | **                            |                              | **                              |                                | **                                 |                                   |

**Table 13-7**

Number of observations, mean and standard deviation of the fish's turning angle (in degrees) after exposure to light. Significant differences ( $P < 0.05$ ) between turning angles from the different treatments in the aquarium experiments, and normal behaviour turning angles is indicated by \*\*.

|      | Light behind | Light in front | Light on the middle | Normal behavior |
|------|--------------|----------------|---------------------|-----------------|
| Mean | 36           | 113            | 93                  | 21              |
| S.D. | 39           | 43             | 49                  | 26              |
| n    | 15           | 15             | 16                  | 353             |
| P    |              | **             | **                  |                 |

The field study demonstrated that whitefish subjected to strobe light increased their swimming speed and increased their distance from the light source. This indicated a behavior that can be classified as a fright and avoidance response. In addition, based on where strobe light is applied relative to the position of a fish, the laboratory study showed that fish can be guided in a certain direction. Possible physical factors that may influence the effectiveness of strobe light include the absorption coefficient, transmission properties, scattering, and depth as well as biological factors such as fish age, physiological condition, and motivation.

### **Laboratory Study – Pacific Northwest National Laboratory (PNNL)**

The effectiveness of strobe lights and infrasound as behavioral barriers for use at diversion facilities was evaluated at the Pacific Northwest National Laboratory (PNNL) (Mueller et al. 1999). The strobe lights tested by PNNL were Flash Technology AGL 901 Aquatic Guidance Lights. Initially, tests were conducted with a single strobe light positioned at the end of the net pen. An additional strobe light was acquired about halfway through the test period. The lights were mounted on an aluminum pole and positioned approximately 0.8 m (2.6 ft) from the end of the net pen. The strobe lights were operated at a rate of 300 flashes per min (fpm) at 400W.



Rainbow trout (*Oncorhynchus mykiss*), brook trout (*Salvelinus fontinalis*), and wild and hatchery fall Chinook salmon (*Oncorhynchus tshawytscha*) were evaluated for avoidance responses to strobe lights during the PNNL study. The average size of each group of fish tested was less than 50 mm (2.0 in.), with the exception of larger brook trout that averaged between 80 and 100 mm (3.1 and 3.9 in.).

Testing was conducted in a large tank with test fish contained in a net pen (1.5 by 1 by 2 m [4.9 by 3.3 by 6.6 ft]). Gridlines were included along the walls, floor, and ceiling to facilitate recording the fish responses. Testing was run in three cycles each day: morning (0700–0900 h), late morning through early afternoon (1100–1300 h), and late afternoon (1400–1600 h). Test groups of 20 fish were exposed to 10, 3-min light-on events during a 1-hour period. Fish behavior during 10, 3-min control periods was also monitored. The light-on and control periods during each 1-hour test were randomly selected. Fish behavior was monitored and recorded on videotape using three underwater cameras. The strength of fish responses was determined by the distances that fish moved during strobe light exposure periods. Responses were classified as follows: (1) none, no movement; (2) slight, 0.15 to 0.3 m (0.5 to 1.0 ft); (3) moderate, 0.3 to 0.8 m (1.0 to 2.6 ft); and (4) strong, >0.8 m (2.6 ft). Responses also were classified based on type of reaction (startle, avoidance, and habituation).

The results from this study indicate variability in fish responses depending upon the species tested. Wild Chinook salmon were more likely to demonstrate avoidance and startle responses when exposed to strobe lights than hatchery Chinook salmon. Activation of the strobe lights caused a startle response followed by a flight path away from the strobe. Rainbow trout fry demonstrated strong avoidance to the strobes. A startle response was followed by flight away from the light source. Very little habituation to the strobe lights was observed. Eastern brook trout exhibited no observable startle response or avoidance to the strobe lights.

### **Laboratory Study – University of Maryland**

Laboratory tests were conducted at the University of Maryland to determine behavioral responses of white perch (*Morone americana*), Atlantic menhaden (*Brevoortia tyrannus*), and spot (*Leiostomus xanthurus*) to different light wavelengths, strobe lights, and a strobe light/air bubble curtain combination (Stauffer et al. 1983 and Sager et al. 1999). Investigations involving behavioral devices, other than strobe light, are discussed elsewhere.

The test facility was a rectangular chamber that could deliver water at regulated flow rates (diffusers and baffles were used to maximize flow evenness). It was 1.8 by 1.2 m (5.9 by 3.9 ft), with a barrier running down the middle of the chamber to within 25.4 cm (10 in.) of the upstream fish barrier. Strobe lights were mounted underwater in the channels created by the barrier. The strobe lights could be controlled individually and could operate at various flash frequencies. Flash rates used were 120, 300 and 600 flashes per min. The water flow rates used for the experiments were 0.2, 0.3, and 0.5 m/sec (0.7, 1.0, and 1.6 ft/sec). Specimens were kept in one of two acclimation rooms on a 12:12 hour day:night cycle, 12 hrs out of synchronization from each other.

Five previously untested specimens were used for each experiment. The fish were allowed to acclimate for 20 min after being introduced into the test tank. After 20 min, the video camera was turned on and the water velocity was initiated. Fish were kept in the chamber with the flow on for 1 hour (without test light stimulus activated). A strobe light was then operated in one of

the test channels and fish behavior was recorded for 1 hour. Replicates were run four times for all test conditions. Videotapes were reviewed and fish positions were plotted at 5-min (2.5-min for white perch) intervals. Observations were made on fish occurrence before and after strobe lights were activated.

White perch, in general, exhibited avoidance behavior to strobe light. Avoidance to strobe light was increased at lower water velocity. Highest avoidance behavior was exhibited by white perch when strobe lights were operated at 300 flashes per min under low light conditions. Spot exhibited avoidance to strobe lights under all conditions, but greatest avoidance was observed for experiments conducted on dark-acclimated specimens at a flash rate of 600 flashes per min. Spot also showed greater avoidance at the lower flow rate. Atlantic menhaden consistently avoided strobe lights under all test conditions. Little difference in avoidance was observed between flash rates, but avoidance was greater under dark conditions and at the higher flow rate.

### ***Laboratory Study – San Onofre Nuclear Generating Station***

Laboratory tests were conducted with strobe lights and overhead incandescent flood lights to determine the feasibility of their application at the San Onofre Nuclear Generating Station (SONGS) in increasing the proportion of fish that enter a fish salvage system (Jahn and Herbinson 2000) (see also discussion on San Onofre louver system in Chapter 12).

The laboratory tests were conducted in three phases from June to December 1995. Strobe lights were used along with a steady light source in the Phase I experiments only. The strobe experiments were conducted with a variable-speed xenon wide-angle strobe light (realistic Catalog number 42-3009A) with an R. S. 272-1146 bulb. The testing apparatus consisted of a box 2.4 by 1.2 by 0.8 m (7.9 by 3.9 by 2.5 ft). The downstream end of the box was divided and led to a 20 cm (8 in.) diameter exit pipe on each side. The upstream chamber could be isolated from the divided portion by lowering a moveable screen. The exit pipes led into fish collection troughs. Water flow was supplied by gravity from a head tank and was introduced into the chamber through a 20 cm (8 in.) diameter down spout directed into a 30.5 cm (12 in.) perforated standpipe.

For the Phase I experiments, a Y-maze with high flows to simulate the conditions near the SONGS traveling screens was employed. Batches of fish were given a choice between exiting the apparatus on a lighted side or a dark side. Fish were transported in a bucket and introduced into the experimental chamber through a large pipe. The pipe was then capped with a light-tight cover for 7 min (the approximate transportation time through the SONGS intake conduits). The light stimulus was then switched on, and the moveable screen was raised so that fish could exit the chamber. After 20 to 30 min, the moveable screen was lowered and a flood light illuminated the chamber. The difference in the number of fish ending up on the north and south sides of the apparatus was recorded. The difference was always computed as north-south, so that a selection by fish for the north side would be a statistically significant positive number and a selection by fish for the south side would be a negative number. It was expected that in the absence of a light stimulus, fish would show no preference for either side. All the data for dark control sets were tested in a one-sample t-test with the null hypothesis  $H_0$  that the mean (n-s) difference = 0. Treatment and dark control test were replicated, up to 10 times each. The number of fish evaluated per test was either six (white croaker) or eight (other species) fish.

Three species, Northern anchovy (*Engraulis mordax*), white croaker (*Genyonemus lineatus*), and Pacific sardine (*Sardinops sagax*), were tested in Phase I. For strobe light tests with white croaker, there was no indication of bias toward one or the other side of the apparatus in either light- or dark-adapted controls. Light-adapted fish reacted negatively to the strobe light presented on the south side but not on the north. Dark-adapted white croaker were repelled by the strobe on both sides, however, the north treatment had a marginal probability and lower power (56%).

Because of their limited quantity, only four experiments were conducted with Pacific sardine. Dark adapted-fish reacted positively to the strobe ( $p < 0.05$ ). No firm conclusions could be drawn from strobe light tests with Pacific sardine because the stimulus was only presented on one side, and a dark-adapted control was not conducted.

Problems were encountered in testing Northern anchovy in late summer and fall since the test fish were scarce and were small enough to swim through the 1.3 cm (0.5 in.) mesh panels in the experimental chamber. The authors report that fish size, as well as day length and season, may have accounted for the difference in behavior in the summer and fall batches of fish. Dark-adapted Northern anchovy showed a mixed reaction (attraction or repulsion) to strobe light, depending on which side of the apparatus the strobe was presented.

### **Laboratory Study – Lee County Hyacinth Control District**

Studies are being conducted by the Lee County Hyacinth Control District (LCHCD) to determine the potential for using strobe lights to control grass carp (*Ctenopharyngodon idella*) movements in Florida waterways (Cassani pers. comm. 1998). Although the purpose of these studies was not to develop methods for reducing fish entrainment, the results have implications for the use of strobe lights at water intakes. Preliminary laboratory tests conducted by the LCHCD were completed in 1998. Testing was conducted in 4.9 m (16 ft) diameter pools using a Flash Technology AGL 901 Strobe system. The study was designed to assess the differences in grass carp swimming behavior and movement between strobe on/off periods.

The experimental design consisted of testing the minimum and maximum strobe light flash rates during four 3-day trials (two trials per flash rate). The strobe light flash head was attached to the pool wall at mid-depth. Water depth in the test pool was about 0.6 m (2.0 ft) and an opaque sheet of plastic (1.0 by 0.5 m [3.3 by 1.6 ft]) was placed in the pool opposite the strobe light to provide a visual refuge. Five grass carp (a pond-cultured, triploid strain) were placed in the pool and acclimated for 3 days before a test was initiated. Response to the strobe lights was assessed by comparing the ambient behavior of a fish group to their behavior during strobe light exposure periods. Ambient behavior was characterized by counter-clockwise swimming around the pool. The time that it took the lead fish to swim completely around the pool was recorded and defined as the "swim interval." The swim interval was the variable that was used to detect differences between ambient behavior and behavior observed during strobe light exposure periods.

The initial behavioral responses of grass carp when the strobe light was activated varied among trials but differed from the counter-clockwise swimming behavior observed during strobe-off periods. Immediate response behaviors included erratic back and forth movement, formation of smaller groups (two or three fish per group versus all fish in one group), and momentary positioning behind the visual barrier. These behaviors were classified as disorientation and typically lasted from 10 to 35 min after the strobe light was activated. When fish resumed

counter-clockwise swimming, the swim interval was decreased from that observed during ambient conditions (i.e., swim speed around the circumference of the pool increased during strobe-on periods), even after 20 hrs of strobe light exposure. Because only preliminary data analyses have been conducted, no information was available with respect to flash rate effects. The general conclusion based on the preliminary analysis of the laboratory data was that strobe light had a measurable effect on grass carp behavior. Further testing was recommended to evaluate grass carp responses under more turbid conditions with natural light and with a refuge where fish could completely avoid the light field.

### **Laboratory Study - Marine Biology Unit at Fawley, U.K.**

Strobe lights were evaluated during laboratory tests at the Marine Biology Unit at Fawley, U.K. to assess their ability to repel or deflect European eels (*Anguilla anguilla*) from water intakes (Haddingh and Smythe 1997). Incandescent and fluorescent lights also were evaluated during this study, and we discuss tests with these lights later. The strobe light used in the evaluation was a 30 W source operated at 600 flashes per min. Tests were conducted in a variable speed flume with an experimental area that was 6.3 by 1.4 by 2.6 m (20.7 by 4.6 by 8.5 ft). Two compartments were located at the downstream end of the test area: one compartment was illuminated from above, the other was not. Infrared cameras and lights were used to observe response of eel to the strobe source. Two tests were conducted with strobe light, one at an illumination level of  $3.1^{-3}$  lux and the other at  $80.1^{-3}$  lux. The flume velocity during each test was set at 0.11 m/sec (0.4 ft/sec). A deflection percentage (i.e., percent of eels entering the non-illuminated compartment) was calculated to assess the deterrent effectiveness. The deflection percentage was 45% at the lower illumination level and 86% at the higher level. The results were statistically significant for both tests. It was concluded that strobe light had potential for successful field application given deployment configurations and illumination levels that allowed downstream migrants adequate time to respond before becoming entrained into an intake.

### **Laboratory Study – EPRI/University of Washington**

Laboratory experiments were conducted at the University of Washington fish hatchery to determine behavioral avoidance and attraction responses of hatchery-reared sub-yearling Chinook salmon (*Oncorhynchus tshawytscha*), coho salmon (*Oncorhynchus kisutch*), Atlantic salmon (*Salmo salar*) and steelhead (*Oncorhynchus mykiss*) to strobe and mercury vapor lights (EPRI 1990). Experiments were performed in an 8.8 by 1.6 by 1.2 m (28.9 by 5.2 by 3.9 ft) outdoor cement raceway. The tests were conducted under no flow conditions at a water depth of 0.65 m (2.1 ft) and ranging in temperature from 12 to 17.5°C (53.6 to 63.5°F). An EG&G model SS-122 underwater strobe light was installed at both ends of the raceway. The strobe was operated at 300 flashes per min. Video cameras were suspended above the raceway to monitor and record behavioral responses.

Fifty fish of one species were used for each test. The fish were introduced into the raceway and allowed to acclimate for 30 min. After the adaptation period had ended, light stimulus was turned on and behavior was monitored. Testing was conducted by using a paired sampling design. At any point in time, only one strobe or one mercury light was operating. The following sequences were evaluated: upstream strobe on followed by downstream strobe on; downstream strobe on followed by upstream strobe on; upstream mercury light on followed by downstream mercury light on; and downstream mercury light on followed by upstream mercury light on.

A test involved illuminating one light for 30 min, then illuminating the other light of the same type (i.e., strobe or mercury) on the opposite ends of the raceway for the same period of time. To ensure that prior exposure to one type of light did not influence the behavioral response to the second light, separate groups of test fish were used in each pair of experiments. Four “trials” (the response of each fish group to a pair of lights) were completed per day. Five replicates of each trial set were completed for each species under daytime (0900 to 1900 hr) and nighttime (1800 to 0300 hr) conditions. Three types of information were obtained from the direct observation data: qualitative observations, attraction and repulsion responses verses time, and the equilibrium response to light.

All species, except for steelhead tested during the day, hid from or avoided the strobe light. During strobe light tests, most fish sought shelter at the far end of the test tank for the duration of each test. These results are consistent with the avoidance responses shown by other species to strobe light both in the laboratory and in the field.

The strobe light avoidance demonstrated by Chinook and coho salmon during the daytime tests was unexpected; it was anticipated that the reduced contrast between ambient day light and test light would decrease avoidance. The very high contrast at night (due to the small test space and the white walls of the tank) appeared to stun fish, and consequently, strobe light avoidance could have been impeded. In contrast, fish were not stunned during the day and swam immediately away from the light. As a result, fish were better able to avoid strobe light during the day than at night. This situation may not occur in the field since natural turbidity and open space would allow fish to respond before they become stunned. Therefore, the authors concluded that strobe lights could be effective in repelling these species under nighttime field conditions. During the day, lack of contrast in the natural environment might render the lights less effective than they were in laboratory tests.

Steelhead trout fry tested under nighttime conditions demonstrated the greatest attraction to mercury lights. Approximately 80% of steelhead fry congregated at the end of the 9.1 m (29.9 ft) long test tank that had an active mercury light. Responses of Chinook and coho salmon to mercury lights were variable.

In experiments conducted by Nemeth and Anderson (1992), fish were tested under four experimental treatment conditions:

- Normal day: fish adapted to ambient daytime conditions (which ranged from full sunlight to heavy cloud cover)
- Normal night: fish adapted to ambient nighttime lighting (which ranged from dusk to complete darkness)
- Reversed day: daytime tests conducted with dark adapted fish
- Reversed night: nighttime tests conducted with fish adapted to an artificial light intensity

The fish were allowed to acclimate for 30 min to natural lighting (in normal day and normal night tests), 30 min to artificial lighting of the reversed night tests, and 60 min to darkness in the reversed day tests. Direct observations were made for the first 5 min and at 5-min intervals thereafter till the end of the 30-min test period. A total of eight replicates were conducted for each of the four experimental conditions with strobes lights for each species. Video monitoring and direct observations were made during the test replicates. Fish behavioral responses were

categorized into primary or secondary behaviors. Primary behaviors occurred throughout a test period, whereas secondary behaviors were sudden or infrequent responses. Both primary and secondary behaviors were further broken down into sub-categories.

Strobe lights caused normal night-adapted coho salmon to hide. Under reversed conditions, there was no clear response of coho to the strobes. In ambient daylight, there was a strong cover-seeking reaction. Chinook salmon, adapted to darkness, showed little or no response to strobe lights. In general, the introduction of strobe lights usually startled both species and occasionally stunned fish, especially under dark conditions. Coho salmon kept a greater distance from the strobe lights than did Chinook. Both species moved to the darkest areas after the initial response and remained in areas away from the lights.

### **Laboratory Study – EPRI/University of Iowa**

In laboratory studies conducted at the University of Iowa, behavioral responses to strobe lights and mercury lights were examined with bluegill (*Lepomis macrochirus*), channel catfish (*Ictalurus punctatus*) (adults and juveniles), walleye (*Sander vitreus*), hybrid striped/white bass, and largemouth bass (*Micropterus salmoides*) (EPRI 1990). The equipment and experimental design were similar to those described above for the University of Washington studies. Bluegill, channel catfish, juvenile walleye, and hybrid bass avoided the strobe light. Juvenile catfish avoided only the brightest sections of the test flume. Largemouth bass exhibited no distinct response. With mercury light, largemouth bass, channel catfish, and walleye were repelled by the light. Other species showed little or no response.

### **Laboratory Study, McIninch and Hocutt**

Laboratory tests conducted by McIninch and Hocutt (1987) examined behavioral responses of three estuarine species to strobe lights, an air bubble curtain, and a combination of the two devices. Tests were conducted at three different turbidity levels (clear, low, and high). The three species evaluated were Atlantic menhaden (*Brevoortia tyrannus*), spot (*Leiostomus xanthurus*), and white perch (*Morone americana*). Atlantic menhaden were not evaluated at the high turbidity level due to unavailability of test specimens. The rectangular indoor test chamber was designed to simulate a cooling water intake system, measuring 7.9 by 2.4 m (25.9 by 7.9 ft) with a water depth of 45.7 cm (18.0 in.). The strobe light sources had a flash power of approximately one watt, a flash duration of about 80 microseconds, and were operated at a flash rate of 300 flashes per min. Light intensity in the test chamber was measured at approximately 4 to 6 microeinsteins per 1 m<sup>2</sup>/sec during the low turbidity tests and 1 to 2 microeinsteins per 1 m<sup>2</sup>/sec high turbidity tests. The strobe light and/or air bubble curtain were activated for 30-min test periods for white perch and 60 min for spot and Atlantic menhaden. The distribution of fish in the tank was recorded at 2.5-min intervals for white perch and 5-min intervals for spot and menhaden. Fish were acclimated to the test chamber prior to behavioral device operation and fish distribution during this period was used as the control condition. Avoidance was measured as the percentage decrease in use of the area affected by a behavioral device.

All three species demonstrated a statistically significant avoidance of strobe light. Avoidance varied among turbidity level and species and, unexpectedly, avoidance was greatest at the high turbidity level for white perch and spot. Fish demonstrated greater avoidance of the strobe light/air bubble barrier than for either barrier tested alone, except for spot tested with highly

turbid water. Because spot and white perch avoided strobe light at high turbidity levels, it was suggested that near- and far-field fish reactions must be considered when deploying strobe lights for fish protection purposes. Increased light scattering due to high turbidity levels may affect near-field reactions and decreases in light transmission may influence far field reactions.

### **Laboratory Study – Ontario Hydro**

Low success rates directing fish into a Hidrostral pump prompted laboratory investigations of behavioral devices to improve collection efficiencies (Rodgers 1983). Laboratory studies were conducted to evaluate strobe lights, mercury vapor lights, electric fields, and a bubble curtain in improving the efficiency of a Hidrostral pump for capturing smelt and alewife (*Alosa pseudoharengus*). Tests involving strobe lights are discussed here. We examine other behavioral devices later.

Tests were performed in a rectangular concrete pool 12 by 6 by 1 m (39.4 by 19.7 by 3.3 ft). The Hidrostral pump (model H5) was mounted on a divider wall. Intake and discharge pipes of the pump extended 2 m (6.6 ft) on either side of the divider wall. A 1 cm (0.4 in.) square mesh fence extended from the side walls and angled to the pump intakes. Strobe lights were attached to the angled walls of the mesh fence at approximately 1.5 m (4.9 ft) from the pump intake. The lights were operated at a frequency of 200 flashes per min and at duration of less than 100  $\mu$ s.

A batch of 25 smelt or alewife were used in each test. Fish were introduced to the intake side of the pool 18 hrs before the pump was started. The pump was run at 600 rpm for 3 hrs. Fish that were discharged into the receiving cage were counted and transferred to a holding cage for 24-hour mortality observations. Strobe lights and other treatments were tested in conjunction with mercury vapor lights over a 3-hour test interval. Treatments were applied for 3-min intervals and repeated every 15 min throughout the test interval. A minimum of two replicates were conducted for each treatment. Data were analyzed using the fixed-effects analysis of variance (ANOVA) model.

The Hidrostral pump alone was ineffective at capturing smelt or alewife. Capture efficiency improved significantly ( $p \leq 0.05$ ) when the pump was used with the mercury light and other treatments. Significant differences were not observed in tests using the mercury light alone. The authors propose that the inability to discriminate between tests using different treatments could have been caused by the high variability in capture efficiency among replicate trials. This may, in turn, have been due to fish schooling behavior.

### **Laboratory Study - Simon Fraser University**

While considerable research has been conducted on the use of strobe light as a behavioral barrier at hydroelectric projects and cooling water intake structures, little research has been conducted on how the light may affect the visual system of the species exposed to it. Therefore, laboratory trials were conducted to evaluate both the behavioral and physical effects of strobe light on fish. Kokanee were collected from a Kakawa Lake feeder creek in Hope, British Columbia, while hatchery-reared sockeye were obtained from an aquaculture supplier (LSL Life Seafoods, Ltd., Langley, British Columbia). All fish were held a minimum of one day prior to testing (Flamarique et al. 2006).

Eight replicate Kokanee (*Oncorhynchus nerka*) were subjected to each treatment duration (1 min-exposure, 5 min-exposure, and controls). Between 8 and 11 replicate sockeye salmon were subjected to each treatment duration (1 min-exposure, 3 hr-exposure, and controls). Kokanee were between 231 g ± 10.7 g and 233 g ± 17.6 g in weight and between 28.5 cm ± 1.51 cm (11.2 in. ± 0.6 in.) and 29.0 cm ± 1.31 cm (11.4 in. ± 0.5 in.) in length with lens diameters between 5.10 ± 0.25 mm and 5.15 mm ± 0.12 mm. Sockeye were between 226 g ± 42.9 g and 236 g ± 45.9 g in weight and between 30.2 cm ± 3.33 cm and 30.9 cm ± 3.04 cm in length with lens diameters between 5.00 mm ± 0.27 mm and 5.11 mm ± 0.34 mm (Flamarique et al. 2006).

Fish receiving the 1-min and 5-min strobe light exposure were anesthetized and placed in an out-of-water fish holding system. During treatment, fish were respired with anesthetically-treated water. Fish were positioned 1 m (3.3 ft) away from the light with the centers of both the fish eye and light aligned. The 3-hr treatments were conducted in the water in a 100-L (26.4-gal) tank. Fish were confined by netting to ensure exposure to the submerged light. For all treatments, the strobe light (AGL-4100B, Flash Technologies, Franklin, Tennessee) was operated at a frequency of 0.167 Hz. Radiance and dose were calculated through the use of a spectroradiometer positioned 1 m (3.3 ft) from the light center (Table 13-8).

**Table 13-8**  
**Integrated power for various regions of the spectrum emitted by the strobe light. Also shown is dosage in the UV-B range (300-320 nm). By comparison, the integrated power for the spectrum reaching the gravel of a clear section of a salmonid nursery stream is in the range of 3.21 x 10<sup>-2</sup> to 4.78 x 10<sup>-2</sup> W/cm<sup>2</sup>/sr (Flamarique et al. 2006).**

| Strobe emission       |                         | Treatment dosage      |           |                         |
|-----------------------|-------------------------|-----------------------|-----------|-------------------------|
| Wavelength range (nm) | W/cm <sup>2</sup> /sr   | Wavelength range (nm) | Treatment | J/cm <sup>2</sup> /sr   |
| 300-320               | 2.67 x 10 <sup>-5</sup> | 300-320               | 1 min     | 1.65 x 10 <sup>-3</sup> |
| 300-400               | 8.99 x 10 <sup>-4</sup> | 300-320               | 5 min     | 8.27 x 10 <sup>-3</sup> |
| 300-700               | 4.25 x 10 <sup>-3</sup> | 300-320               | 3 hr      | 9.98 x 10 <sup>-2</sup> |

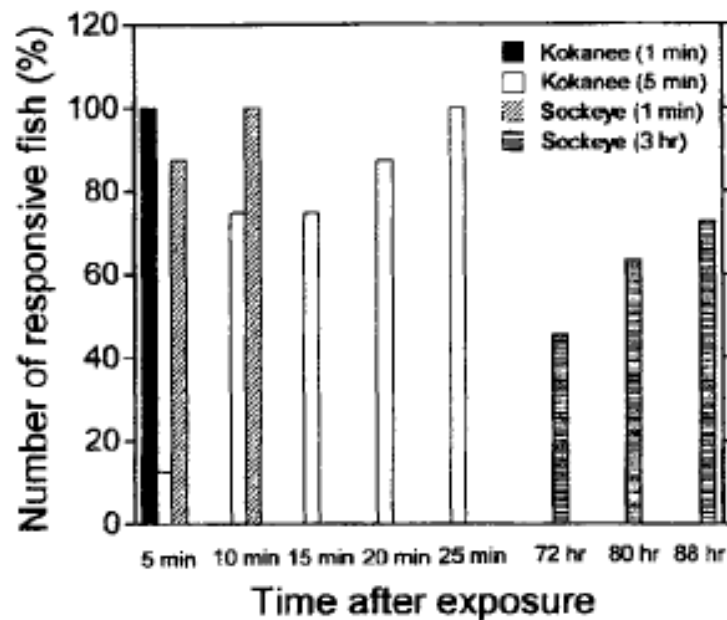
After recovery from the strobe treatments, response to a simulated predator shadow (cardboard on a stick) was evaluated. For fish that had received the 1- or 3-min treatments, the shadow was passed over the tank every 5 min; for fish that had received the 5 hr treatment, the shadow was passed over the tank every 8 hr.

Subsequent histological examinations were conducted to determine the level of physical damage to the retina and photoreceptors. Kokanee were euthanized 3-5 days after treatment and the sockeye 90-92 days after treatment. Retinas were removed, flattened, cut into quadrants, sectioned (tangentially and radially), and stained in order to quantify cone densities and areas. A total of five eyes (left eye) were analyzed per treatment.

Results of the behavioral trials are presented in Figure 13-6. In the 1-min treatment, all of the Kokanee displayed an avoidance response to the simulated predator shadow within 5 min post-treatment, while all of the sockeye responded within 10 min. In the 5-min treatment group, all Kokanee responded within 25 min post-treatment (one responded within 5 min). In the 3-hr



treatment group, three sockeye died within one week; while the remaining eight responded within 88 hr post-treatment (controls responded immediately).



**Figure 13-6**  
**Percentage of Kokanee and sockeye salmon that responded to an overhead shadow after strobe light exposure for various amounts of time as a function of time after exposure. Note that 3 sockeye salmon in the 3-hr-exposure group died before any reaction was detected; hence, the cumulative bar graph never attains 100% from this treatment (Flamarique et al. 2006).**

No significant differences were noted between cone densities and areas of control or treatment fish. Furthermore, no irregularities were noted in the lenses of any of the fish other than the three sockeye that died after the 3-hr treatment. These fish displayed lens damage and internal eye hemorrhages.

It was concluded that short-term exposure to strobe light (<5 min) does not cause retinal damage. Therefore, intermittent exposure to strobe lights installed at hydro projects or cooling water intake structures is not likely to cause retinal damage to Kokanee or sockeye salmon.

## **Case Studies – Mercury Light – Hydroelectric Field Tests**

### ***Weldon Dam, Mattaceunk Project***

Mercury lights have been evaluated as part of integrated fish protection systems at two hydro sites in New England. At the Mattaceunk Project (Weldon Dam), mercury lights were used in attempts to improve bypass collection efficiency of outmigrating Atlantic salmon (*Salmo salar*) smolts (Great Northern Paper 1995, 1998). The Mattaceunk Project also has partial bar rack overlays that reduce spacing to 2.5 cm (1 in.) clear to a depth of 5 m (16.4 ft), and strobe lights have been evaluated at the intake as a deterrent device, as we previously discussed. The mercury lights were marginally effective in increasing the passage of smolts into the bypass.

## ***Various Dutch Stations and Water Bodies***

In attempts to reduce entrainment of migrating European eels into water intakes, various light devices were evaluated at the Bergum, Haandrik, Amer, and Dietfurt power stations located in the Netherlands (Haddingh and Smythe 1997). Bergum and Amer are cooling water intakes, while Haandrik and Dietfurt are hydroelectric project intakes. Underwater incandescent and overhead mercury lights were evaluated at the Bergum and Haandrik stations, while underwater fluorescent lights were tested at the Amer and Dietfurt stations. Additionally, field studies were conducted on the Vecht and Regge rivers at commercial fishery sites to evaluate the ability of underwater incandescent lights to guide migrating eels to fyke nets located near one side of the river. We provide a brief description of the light barriers, sampling design, and results from studies at each site below.

At the Bergum thermal power station, a light barrier consisting of incandescent lights mounted on the river bottom and mercury lights suspended 1 m (3.3 ft) above the water surface was placed 5 m (16.4 ft) upstream of one of the station's two CWISs. Entrainment at the two units was compared to evaluate the ability of the lights to repel eels. Deflection percentages were calculated based on the assumption that eel entrainment into each unit was the same in the absence of lights. Tests were conducted on 10 nights in 1987. The estimated deflection rate was 51% for yellow eels and 25% for silver eels.

The light barrier evaluated at the Haandrik hydropower station consisted of underwater incandescent and above-water mercury lights deployed 4 m (13.1 ft) in front of powerhouse intake. Nine incandescent lights were mounted on the river bottom at a depth of about 2.6 m (8.5 ft), and two mercury lights were suspended 1.5 m (4.9 ft) above the water surface. A bypass weir was located next to the intake. The effectiveness of the lights was determined by comparing the number of turbine-entrained eels collected during nights with the lights on and off. Sampling was conducted on nine nights during September and October in 1988. The estimated deflection percentage of the Haandrik light barrier was 66%.

At the Amer thermal power station, a light barrier consisting of 30 fluorescent lamps was deployed on the river bottom about 8 m (26.2 ft) upstream from the plant's cooling water intake. Sampling was conducted over 17 nights in September and October 1995. The estimated deflection rates for yellow and silver eels were 62 and 74%, respectively.

An angled array of 79 fluorescent lights was evaluated at the Dietfurt hydropower station in 1996. The lights were deployed on the river bottom at an angle of 20 degrees to the flow about 80 m (262 ft) upstream of the turbine intake. Based on one night of sampling data, the deflection rate of eels was estimated to be 8%.

Eel diversion studies with incandescent lights were conducted on the Vecht and Regge rivers between 1988 and 1990. At the study sites on both rivers, a row of incandescent lights (200 W) extending about two-thirds of the width of the channel were mounted on the river bottom. The illumination level was 10 lux at a distance of 1.5 m (4.9 ft) upstream of the light barriers. Deflection percentages were calculated using eel collection data from nets deployed behind the barriers. At the River Regge site, sampling was conducted on 52 nights in 1988 and on 12 nights in 1989. Sampling on the River Vecht was conducted on 126 nights in 1990. The deflection rate for the River Regge barrier was 85% in 1988 and 76% in 1989. The deflection percentage of the River Vecht barrier was 73%.

### **York Haven Hydroelectric Project**

In addition to the strobe light studies described previously, mercury lights were evaluated to determine whether they could improve the passage of juvenile American shad (*Alosa sapidissima*) through the sluiceway bypass at the York Haven Hydroelectric Project (EPRI 1990, 1992b; Martin et al. 1991; Martin and Sullivan 1992). Mercury lights were evaluated to determine their ability to guide juvenile shad into an existing trash sluiceway. Two 1,000 watt mercury lights were positioned about 0.6 m (2 ft) below the water surface on opposite sides of an ice/trash sluiceway. The lights were arranged to illuminate the area immediately in front of the sluiceway gate. Poor results in the first tests prompted changes in the mercury light arrangement. Only one light was used and was lowered to a depth of 1.5 m (5 ft). Later on, the light was lowered again to a depth of 4.3 m (14 ft). In 1991, a lower-intensity mercury light was evaluated. The 250 watt light was set 3.0 m (10 ft) in front of the sluiceway at a depth of 0.9 m (3 ft).

The mercury lights were evaluated by using scanning sonar and a netting program. The scanning sonar system (WESMAR Model SS390) was used to monitor fish response to the various test devices. The mercury lights caused a reduction of fish in the immediate vicinity of the light, however, fish acclimated to the light and the effect was not sustained. The 250 watt mercury light did not strongly attract American shad. Gizzard shad (*Dorosoma cepedianum*), on the other hand, were very strongly attracted to mercury light and were observed to rapidly pass through the sluice gate when opened.

### **Poutès Dam**

Studies were conducted in 1989 at Poutès dam on the Allier River to evaluate the effectiveness of mercury lights in modifying behavioral responses of Atlantic salmon (*Salmo salar*) smolts at a fish bypass structure (Larinier and Boyer-Bernard 1992). Visual observations and video recording of hourly and daily passage rates were used to evaluate mercury light effectiveness.

Mercury lights significantly increased passage rates of smolts. Three to eight times more fish were bypassed with the lights on than with the lights off. The effect of the lights was not immediate: Passage rates did not reach their maximum until more than a half an hour following the activation of the lights. Illumination duration, light location, and light intensity, were determined by visual observations to be important parameters in effective application of mercury lights for attraction.

### **Wanapum Dam**

Studies were conducted at Wanapum Dam to determine the potential effectiveness of mercury lights in improving the passage of outmigrating salmon via the spillway gates (EPRI 1990). The project is located on the Columbia River in Grant County, Washington and consists of 10 turbines, 12 bottom-spill tainter gates, and one top-spill sluice gate.

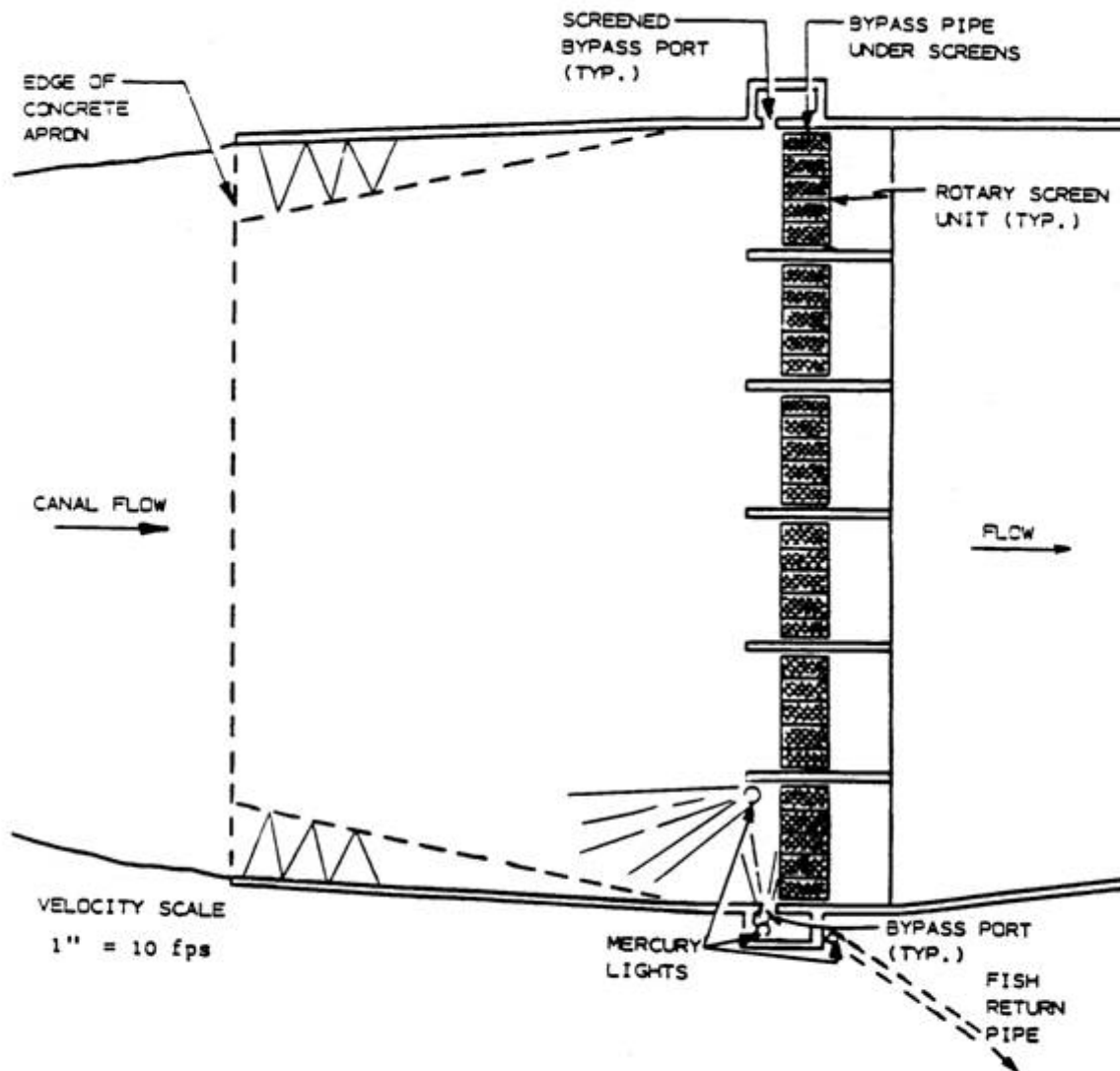
The mercury lights were installed on two adjacent pier noses on one spillway gate. Lights were set at two depths: 3.0 m (10 ft) for the first half of the test period and 6.1 m (20 ft) for the second. Hydroacoustic techniques were used to monitor fish passage. Monitoring the spill 7 days prior to initiation of the mercury light treatment generated baseline data. The lights were tested in a paired design within each day. An on/off (test/control) sequence was alternated from one night

to the next. The on and off periods were of equal lengths of time on a given night when fish were actively migrating.

Results showed great variability in passage rates from day to day over the 29 days of sampling. Statistical analysis indicated that the lights had no effect on fish passage rates. The authors suggest that the results should be considered inconclusive due to a short outmigration period and the fact that the light illuminated a relatively small area relative to the total spillway area.

### ***Wapatox Canal Fish Screening Facility***

Mercury lights were evaluated to assess their effectiveness at maximizing the number of juvenile salmon and steelhead trout using the diversion system at the Wapatox Canal Fish Screening Facility (EPRI 1990). The canal is located on the Naches River one-half mile from the confluence of the Naches and Tieton River in Washington. Flow rate in the canal ranged from 8.5 to 14.2 m<sup>3</sup>/sec (300 to 500 cfs). Water from the diversion is used for irrigation and hydroelectric power. The diversion system was made up of six drum screens oriented perpendicular to the river flow (Figure 13-7).



**Figure 13-7**  
**Modified light orientation Wapatox — plan view (EPRI 1990)**

Five of the six screens were covered with 0.64 cm (0.25 in.) mesh. The sixth was covered in 0.32 cm (0.13 in.) mesh. Vertical slot fish bypass entrances were located on the left and right banks of the canal.

A fish return pipe transported the diverted fish to the river 366 m (1,200 ft) downstream of the canal diversion. A 1,000 watt underwater mercury light was located on the left side of the canal at the left bypass entrance. An additional mercury light was located inside the left bypass entrance in order to illuminate the bypass slot.

Mercury light effectiveness was determined by comparing estimated fish passage rates for the bypass during periods with the lights on and off. Paired testing strategy was employed. Fish movement was monitored in several ways. Rate of passage was monitored by removing and counting fish collected in the smolt trap every 10 to 15 min. Impingement on the drum screens was also monitored occasionally, and observations of fish behavior were recorded.

During spring tests, overall fish bypass rates did not differ between light and dark conditions. Based on increases in passage rates immediately after a light condition change, it was believed that the fish were attracted to the mercury light but were avoiding the area of brightest illumination at the bypass openings. Typically, when the mercury lights were turned on fish were attracted to, but would not enter, the bypass. When the lights were turned off fish would move into the bypass. Consequently, the mercury light orientation and operation scheme were modified for fall tests. Test and control periods were alternated between the first and last half of each night, and during the test periods the light was cycled off for 5 min each hour in order to "pulse" fish into the bypass. A substantial increase in outmigrant (Chinook salmon [*Oncorhynchus tshawytscha*] and Kokanee salmon [*Oncorhynchus nerka*]) passage rates was observed during fall tests with the new array and operation scheme. Nearly twice as many fish were bypassed with the lights on (863 fish) than with the lights off (451 fish).

The drum screens were eventually replaced with fixed-panel, angled wedgewire diversion screens.

### **Hadley Falls Hydroelectric Project**

Studies were conducted examining the use of mercury light to modify behavioral responses of American shad (*Alosa sapidissima*) and blueback herring (*Alosa aestivalis*) at the Hadley Falls Hydroelectric Project located on the Connecticut River in Holyoke, Massachusetts (LMS 1989). A generating station and a power canal are located on the west side of the dam. Several additional hydroelectric units operate within the canal system. Two units (1 and 2) are located 37 m (121.4 ft) downstream of the canal gatehouse. The combined power generating capacity of units 1 and 2 is approximately 33 MW. Each unit has a maximum flow of 119 m<sup>3</sup>/sec (4,200 cfs).

The mercury light system was a 1,000-watt Hydro-Products model L2 underwater mercury light. The output was 54,000 lumens, and it was rated to a 1,200 m (3,937 ft) depth. Two lights were mounted on the west side of the bascule exit, and two were located on the east. Both were set at a depth of approximately 1 m (3.2 ft) below the water. The lights were turned on or off for each 90-min sampling period. The turbine tailrace and bascule gate discharges were netted simultaneously, and catches were compared. ANOVA statistical analysis was used to compare the bascule passage rates between lighted and unlighted conditions.

There was no significant difference in passage rates of American shad and blueback herring under either the lighted or unlighted condition. A total of 11,943 fish were collected. The majority of the catch (97%) was comprised of American shad (7,140 fish) and blueback herring (4,457 fish). An analysis of lights-on versus lights-off within a night resulted in 63.4% of shad and 58.6% of blueback herring passing during the unlighted periods. An analysis of lights-on versus lights-off across nights revealed the passage of 65.0% of shad and 59.5% of blueback herring during unlighted periods.

### **Annapolis Tidal Generating Station**

Mercury lights, a fishdrone, and a fishpulsar (hammer) were evaluated as fish protection devices at the Annapolis Tidal Generating Station (McKinley and Kowalyk 1989). The fishdrone and mercury lights were tested as fish attractants, and the fishpulsar was tested as a deterrent. The tests performed with only the sound devices are discussed in later sections. Mercury light was evaluated for its ability as an attractant for alewife (*Alosa pseudoharengus*), blueback herring (*Alosa aestivalis*), and American shad (*Alosa sapidissima*). The station is located on the Annapolis River estuary near Annapolis Royal, Nova Scotia. The station houses a STRAFLO turbine that generates 20 MW during ebb tide.

A two-phase study was conducted at the Annapolis Project to examine the behavioral responses of adult (Phase 1) and juvenile fish (Phase 2) to the three devices (alositids appeared to be the dominant fish species occurring at the project). Each protection device was tested alone, and mercury lights also were tested with each sound device. Several filtered mercury vapor lights were used in the experiments conducted at Annapolis. The filter was employed to obtain light in the blue-green wavelengths. Mercury lights were used to attract fish toward a Hidrostral pump. The lights were estimated to penetrate the water approximately 3 m (9.8 ft). All tests were conducted at night between the hours of 1700–0600. Replicates were conducted several times, and each had a duration of at least 5 min. Three fixed acoustical transducers were used to monitor fish distribution at the fish bypass, turbine, and sluiceway areas. Surface gill netting was also employed to supplement hydro acoustic data.

The results from Phase 1 tests indicated that adult fish were slightly attracted to the mercury lights. Hydro acoustics data indicated that fish activity increased slightly in the area in front of the fish bypass when the mercury lights were turned on. Visual observations revealed only a few fish entered the higher light intensity zones created by the mercury lights. Few fish were observed during Phase 2 tests. Tests conducted with juvenile fish were similar to the previous tests with adult fish, showing only a slight attraction to mercury lights.

### **Bellows Falls Hydroelectric Project**

Mercury lights (overhead and underwater) were deployed at the Bellows Falls Hydroelectric Project in attempts to guide Atlantic salmon (*Salmo salar*) smolts to a sluiceway for downstream passage (Saunders and Mudre 1988). The mercury lights were placed on two sections of a log boom in the powerhouse forebay (overhead configuration) and at the sluiceway entrance (underwater configuration). Several flow scenarios also were evaluated as means to increase smolt passage through the sluiceway.

The primary method of evaluation involved radio telemetry techniques; netting was conducted and evaluated as an alternative sluiceway sampling method. Hydroacoustic techniques also were used to monitor fish movement through the sluiceway. Radio tagged smolts were released into the power canal, and downstream movement of fish was assessed for passage route use (i.e., sluiceway, turbines, or a fish bypass pipe). Controlled smolt releases were used to evaluate the efficiency of sluiceway netting.

Data collected from four radio telemetry experiments and from ambient netting indicated that the use of mercury lights did not increase smolt passage through the sluiceway. In contrast, the results of from the controlled release sampling indicated that the lights improved smolt use of the

sluiceway. Also, sluiceway flow regimes apparently did not influence the effectiveness of the mercury lights. It was concluded that the mercury lights at Bellow Falls were not an effective fish attractant or guidance system. Subsequently, an angled barrier wall was installed to guide fish to the sluiceway.

### **Priest Rapids Dam**

An investigation was conducted at Priest Rapids Dam to evaluate the effectiveness of mercury vapor lights in facilitating shad passage (Pock 1988). The effect of the mercury light on the upstream migration of salmonids was also evaluated. Ten Hydro Products Model L2, 130 degree beam angle, 1,000 watt mercury vapor lamps were installed above the submerged openings of the five control weirs.

Passage of shad above the control structures was based on visual observations of shad moving through the Denil fishway and on counts of incidental collection of shad in Coded Wire Tag (CWT) traps. The light system was operated from June 9 to July 27, 1988. Light configurations, with respect to timing, duration, orientation, and intensity were varied based on observations. For the first 6 days, the lights were operated from 0900 to 1900 at 100% intensity. Intensity of the lights was lowered to 50% because no movement of shad was observed in the ladder sections or through the Denil. The lights were kept at 50% for the next 7 days with some variations in timing and duration. Lights were then operated from 2100 to 1000 at variable intensities: 50% for 5 days, 25% for 4 days, 100% for 6 days, 75% for 2 days, and 12.5% for the last 12 days of operation. The light beam pattern was rotated 90 degrees in order to direct more light into the entrances of the fishways. The lights were operated at 50% intensity for 5 days and at 100% intensity for 2 days from 2100 to 0900 hrs in this configuration. The CWT began operation on April 19, 1988, and ran through August 27 from 0900–1900 hrs.

Mercury lights did not promote or enhance shad passage through the ladder control structures. The only shad that were observed in the upper control structures were proposed to have passed as a result of sheer numbers and not voluntary passage.

### **Cabot Station**

The feasibility of using filtered and unfiltered underwater mercury vapor lights for attracting American shad and blueback herring juveniles to a bypass facility was examined at Cabot Station (NUSCO 1986). Cabot Station is part of the Turners Falls Hydroelectric Project located on the Connecticut River in Massachusetts. Experiments were conducted in an enclosed section of a fish ladder that is adjacent to Cabot Station.

Two 250-watt underwater mercury lights were installed on movable fixtures, one each at the upstream and downstream ends of the test enclosure. The amount of color tint provided by blue filters (Roscolux #80 and #69) and distance between the two lights were varied among tests. After 1 or 2 hrs during each of the tests, the position of the fish relative to the light was recorded. Each test was recorded on video tape to document behavioral responses. Control tests (no lights) were performed to determine fish behavior in the absence of mercury light and to determine if fish exhibited a diurnal behavior pattern.

Juvenile American shad (*Alosa sapidissima*) and blueback herring (*Alosa aestivalis*) (n = 60) were introduced into the test flume and allowed to acclimate for a 2-hour period prior to testing.



Positions of fish were recorded on an hourly basis while a single light was operating. The light was on for 1 to 2 hrs then turned off; the opposite light was then turned on. The alternation of the on/off scheme continued for the duration of the test.

Preliminary study results indicated that juveniles of both alosid species were attracted to the mercury lights only during periods of darkness. This response was attributed to the level of background illumination (13,000 lux) during daylight, compared with the maximum light intensity (4,355 lux) created by the mercury lights. Fish response was considerably stronger when the lights were placed about 3 m (10 ft) apart than when they were about 4.9 m (16 ft) apart. Attraction to unfiltered lights appeared to be at least as strong, if not stronger, than attraction to the blue-filtered lights.

An overhead mercury light was used to illuminate a new type of bypass weir (NU-Alden weir) at the Turners Falls Hydroelectric Project (Cabot Station; NUSCO 1997). An evaluation of the weir and light system at Cabot station was conducted to determine the bypass efficiency of Atlantic salmon (*Salmo salar*) smolts. To encourage fish movement toward the weir, overlays are placed over the existing bar racks to reduce the spacing during the migratory period. The overhead mercury light appeared to contribute to increased passage of smolts through a sluiceway. The positioning of the light was important to improving bypass efficiency. The positioning of the light was important to improving bypass efficiency.

## **Case Studies – Mercury Lights – Cage Studies**

### ***Kingsford Hydroelectric Station***

Cage tests were conducted at the Kingsford Hydroelectric Project in Wisconsin to evaluate the response of potamodromous fish species to several behavioral devices, including mercury light (Winchell et al. 1997; EPRI 1998a, b; Michaud and Taft 2000). A detailed description of study methods was provided previously in the discussion of strobe light experimental evaluations.

Species evaluated during the mercury light cage tests included bluegill (*Lepomis macrochirus*) and pumpkinseed (*Lepomis gibbosus*), walleye (*Sander vitreus*), rainbow trout (*Oncorhynchus mykiss*), largemouth bass (*Micropterus salmoides*) and smallmouth bass (*Micropterus dolomieu*). Testing involved exposing groups of fish to mercury light from sources located at either end of the cage. Each light source was operated for 5 min during 10-min exposure periods. None of the fish that were tested exhibited any discernible response to mercury light. Based on the results, it was concluded that mercury light was not a viable fish protection technology for use with the species that were evaluated.

## **Case Studies – Mercury Lights – Laboratory Studies**

### ***Laboratory Study – EPRI/University of Washington***

Laboratory experiments were conducted at the University of Washington fish hatchery to determine behavioral avoidance and attraction responses of hatchery-reared subyearling Chinook salmon (*Oncorhynchus tshawytscha*), coho salmon (*Oncorhynchus kisutch*), and Atlantic salmon (*Salmo salar*) and steelhead trout (*Oncorhynchus mykiss*) to strobe and mercury vapor lights (EPRI 1990; Puckett and Anderson 1988). Tests were performed using both light and dark

adapted juvenile Chinook, coho, and Atlantic salmon and steelhead trout. The facility used was the same as that described previously for the strobe light studies conducted at this site.

Fifty fish of one species were used for each test. The fish were introduced into the raceway and allowed to acclimate for 30 min. After the adaptation period had ended, light stimulus was turned on and behavior was monitored. Testing was conducted by using the paired sampling design described previously for strobe light studies. The greatest attraction to mercury lights was demonstrated by steelhead trout fry tested under nighttime conditions. Approximately 80% of steelhead fry congregated at the end of the 9.1 m (30 ft) test tank that had an active mercury light. Responses of Chinook and coho salmon to mercury lights were variable. Steelhead were attracted to the light, but all other species failed to respond. The number of steelhead within 2.7 m (9 ft) of the light increased with time for the first 15 min, and they swam relatively quickly toward the second test light when activated. The attraction appeared to be a function of exposure time. Chinook and coho tended to swim up and down the length of the raceway during the mercury light tests, indicating a complex behavioral response to the lights.

In additional experiments conducted by Nemeth and Anderson (1992), fish were tested under four experimental treatment conditions:

1. Normal day: fish adapted to ambient daytime conditions (which ranged from full sunlight to heavy cloud cover)
2. Normal night: fish adapted to ambient nighttime lighting (which ranged from dusk to complete darkness)
3. Reversed day: daytime tests conducted with dark adapted fish
4. Reversed night: nighttime tests conducted with fish adapted to an artificial light intensity

The fish were allowed to adapt for 30 min to natural lighting (in normal day and normal night tests), 30 min to artificial lighting of the reversed night tests, and 60 min to darkness in the reversed day tests. Direct observations were made for the first 5 min and at 5-min intervals thereafter till the end of the 30-min test period. A total of eight replicates were conducted for each of the four experimental conditions with mercury light for each species. Video monitoring and direct observations were made during the test replicates. Fish behavioral responses were categorized into primary or secondary behaviors. Primary behaviors occurred throughout a test period, whereas secondary behaviors were sudden or infrequent responses. Both primary and secondary behaviors were further broken down into sub-categories.

The greatest and most consistent changes observed in coho salmon were from exposure to mercury light at night. No clear response was noted under reverse conditions. Chinook salmon increased their activity when exposed to mercury light. Under normal conditions during daylight hours, however, Chinook salmon were relatively inactive. Little or no changes in response were observed during reversed treatments.

### ***Laboratory Study – Ontario Hydro***

Low success rates in directing fish into a Hidrostral pump prompted laboratory investigations in the use of behavioral devices to improve collection efficiencies (Rodgers 1983). Laboratory studies were conducted to evaluate strobe lights (as we discussed previously), mercury vapor

lights, electric fields, and a bubble curtain in improving the efficiency of a Hidrostral pump for capturing smelt and alewife.

Tests were performed in a rectangular concrete pool measuring 12 by 6 by 1 m (39.3 by 19.7 by 3.2 ft). The Hidrostral pump (model H5) was mounted on a divider wall. Intake and discharge pipes of the pump extended 2 m (6.6 ft) on either side of the divider wall. A 1 cm (0.4 in.) square mesh fence extended from the sidewalls, then angle to the pump intakes. A filtered mercury vapor light was placed directly behind the pump intake.

A batch of 25 smelt or alewife was used in each test. Fish were introduced to the intake side of the pool 18 hrs before the pump was started. The pump was run at 600 rpm for 3 hrs. Fish that were discharged into the receiving cage were counted and transferred to a holding cage for 24-hour mortality observations. All of the treatments were tested in conjunction with mercury vapor lights over a 3-hour test interval. Treatments were applied for 3-min intervals and repeated every 15 min throughout the test interval. Two replicates were conducted for each treatment. Data were analyzed using the fixed-effects analysis of variance model.

The Hidrostral pump alone was ineffective at capturing smelt or alewife. Capture efficiency improved significantly ( $p \leq 0.05$ ) when the pump was used with the mercury light. Significant differences were not observed between tests using the mercury light alone or in combination with other devices.

## **Case Studies – Other Light – Hydroelectric Field Tests**

### ***Richard B. Russell Pumped Storage Project***

Overhead, high-pressure sodium lights have been evaluated as part of an integrated fish protection system employed at the Richard B. Russell Pumped Storage Project located on the Savannah River between South Carolina and Georgia (Pickens 1992; Ploskey et al. 1995; Nestler et al. 1995b, 1998). The sodium lights were evaluated mainly for their ability to attract blueback herring to low-velocity tailrace areas where they would be less likely to become entrained during pumpback operations. The effectiveness of the lights was determined by comparing densities of fish in lit and unlit tailrace areas using hydroacoustic sampling techniques. In tests using fixed-aspect hydroacoustics, mean densities of fish under a single sodium light were shown to be significantly higher than densities in an adjacent unlit area with a similar depth. Data collected from transects sampled with mobile hydroacoustics also demonstrated that mean densities of fish were significantly greater in tailrace areas illuminated with sodium lights. Based on these results, the use of overhead sodium lights has been incorporated into the final design of the integrated fish protection system that has been proposed for use at this site.

### ***Halsou Hydroelectric Plant***

Exploratory tests were conducted with halogen and mercury lights during the evaluation of a downstream bypass for Atlantic salmon smolts at Halsou Hydroelectric Plant, on the Nive River in southwest France (Larinier and Boyer-Bernard 1992). Daily, diurnal, and hourly passage was determined by video recording and trapping. Tests with marked fish indicated that between 42 and 95% of the smolts used the surface bypass. Passage rates increased significantly when the bypass discharge was increased. Visual observations also revealed that fish were attracted to the

lights, but avoided the point source. When the bypass lights were shut off, the rate of passage through the bypass increased.

### ***Various Hydroelectric Projects in the Northeast – Weldon Dam, Mattaceunk Hydroelectric Project, Rolfe Canal, Pejepscot Hydroelectric Project, Cabot Station***

Overhead and/or underwater lights (i.e., other than mercury or strobe lights) have been evaluated during field studies as means to attract fish to surface bypasses at several hydro projects in the Northeast. Most of the bypasses where lights were installed were part of downstream passage facilities designed for anadromous outmigrants (e.g., Atlantic salmon [*Salmo salar*] smolts and juvenile American shad [*Alosa sapidissima*] and river herring). Overhead lights usually were located above and/or immediately downstream of bypass weirs to backlight the entrance. Evaluations of passage facilities that included overhead lights had produced mixed results. Marginal increases in bypass efficiency were demonstrated in some studies, whereas others showed no increase in passage rates. Many of these studies, however, were not subjected to rigorous analyses that might have quantified the actual effect of overhead lighting (i.e., the use of bypasses with and without overhead lights was not statistically compared during most studies). Other parameters that affect bypass efficiency (e.g., hydraulic conditions, project operation, bypass configuration and location) may have overridden the ability of overhead lights to increase passage. In some cases, fish may have been attracted by the lights, but would not enter the bypass due to unfavorable hydraulic conditions. Even if increases in bypass efficiency are relatively low (e.g., 5 to 10%), the use of overhead lights may be justified at some sites because the costs of installation, operation, and maintenance are low.

### ***Rosa Diversion Dam***

The response of Chinook salmon (*Oncorhynchus tshawytscha*) smolts to a drop light was evaluated during cage tests conducted at the Roza Diversion Dam located on the Yakima River in Washington (Amaral 1998). During this study, several behavioral devices were examined for their potential to guide outmigrating smolts to the screening facilities at Roza. A detailed description of the study methods and test facilities was described in the section on strobe lights. The drop light was evaluated during 12 separate tests, nine of which were conducted with a 1-min exposure period and three with a 2-min exposure period. The 1-min tests were conducted during daytime, dusk, and nighttime hours (three tests per time of day), and the 2 min tests were all conducted at night. A new group of fish (between 12 and 25 fish) was used for each test. Fish were exposed to drop light stimuli that included continuous light operation and turning the light on and off at one and 15 second intervals. Responses to the drop light were assessed by comparing fish school positions during control and treatment periods. Although some movement of fish away from the light source was noted during several of the drop light tests, the distance moved was minimal (less than 1.0 m [3.3 ft]) and speed of movement was slow. Also, there was no indication that time of day affected fish response to the drop light. Based on the lack of response exhibited by Chinook salmon during most tests, it was concluded that drop lights should not be considered for application at Roza.

## **Case Studies – Other Light – Cage Tests**

### ***Kingsford Hydroelectric Project***

Cage tests were conducted at the Kingsford Hydroelectric Project in Wisconsin to evaluate the response of potamodromous fish species to several behavioral devices, including overhead high-pressure sodium lights. A detailed description of study methods was provided previously in the discussion of strobe light experimental evaluations. Species evaluated during the sodium light cage tests included bluegill (*Lepomis macrochirus*), pumpkinseed (*Lepomis gibbosus*), walleye (*Sander vitreus*), rainbow trout (*Oncorhynchus mykiss*), and smallmouth bass (*Micropterus dolomieu*). Testing involved exposing groups of fish to light from sources located above either end of the cage. Each light source was operated for 5 min during 10-min exposure periods. None of the fish that were tested exhibited any discernible response (attraction or repulsion) to the illumination from the sodium lights. Based on the results, it was concluded that high-pressure sodium lights do not have potential for use as a fish protection technology with the species that were evaluated.

## **Case Studies – Other Light – Laboratory Studies**

### ***Laboratory Study – University of Maryland***

Laboratory tests were conducted at the University of Maryland to determine behavioral responses of white perch (*Morone americana*), Atlantic menhaden (*Brevoortia tyrannus*), and spot (*Leiostomus xanthurus*) to different light wavelengths, strobe lights (discussed previously), and a strobe light/air bubble curtain combination (Stauffer et al. 1983 and Sager et al. 1999). The test facility was a rectangular chamber that could deliver water at regulated flow rates (diffusers and baffles were used to maximize flow evenness). It was 1.8 by 1.2 m (6 by 4 ft), with a barrier running down the middle of the chamber to within 25.4-cm (10-in.) of the upstream fish barrier. Eleven Kodak 600H Carousel projectors, with quartz-halogen dichroic reflector lamps, were focused into a series of eleven baffle chambers in the test trough. The halogen lights could be controlled individually and could operate at various intensities. Electromagnetic band widths were separated using narrow band interference filters. Wavelength transmissions of 460, 480, 500, 520, 560, 580, 600, 620, 640, and 660 nm were used in the experiments. The water flow rates used for the experiments averaged either 0.5 m/sec (1.5 ft/sec) or 0.2 m/sec (0.6 ft/sec). Specimens were kept in one of two acclimation rooms on a 12:12 hour day:night cycle, 12 hrs out of synchronization from each other.

Five new (previously untested) specimens were used for each experiment. The fish were allowed to acclimate for 20 min after being introduced into the test tank. After 20 min, the video camera was turned on and the water velocity was initiated. Fish were kept in the chamber with the flow on for one hour without test light stimulus. Test specimens could be introduced into the test trough at either end of the spectrum. All the species were tested at three light intensities, but the number of test replicates varied. Ten spot and white perch were tested under all conditions for a total 60 tests. Twenty menhaden were also tested under all conditions for a total of 120 tests. The light wavelength preference data were statistically analyzed using a Chi-square analysis.

White perch exhibited an escape rather than the expected preference behavior. They did not exhibit a preference for any wavelength of light used in the tests. Spot exhibited great variability in light wavelength preference between individual specimens. In general, spot tended to prefer shorter wavelengths. No preference was clearly indicated by spot.

### **Laboratory Study - Marine Biology Unit, Fawley, UK**

Laboratory tests with various light devices were conducted to assess their ability to repel or deflect European eels (*Anguilla anguilla*) from water intakes (Haddingh and Smythe 1997). The light sources that were evaluated included incandescent lights (200 W, continuous spectrum), fluorescent lights (36 W with spectrum peaks at 440, 550, and 610 nm), and strobe lights (30 W, 600 flashes per min). Evaluations of eel responses to each light were conducted in a variable speed flume with an experimental area that was 1.4 by 6.3 m (4.6 by 20.7 ft) long with a water depth of 2.6 m (8.5 ft). Two compartments were located at the downstream end of the test area; one compartment was illuminated from above, the other was not. Infrared cameras and lights were used to observe response of eel to each light device. Illuminations that were evaluated for each light type included 1.4 and 10.4 lux for incandescent light,  $7.1^{-3}$  and 1.5 lux for fluorescent light, and  $3.1^{-3}$  and  $80.1^{-3}$  lux for strobe light. Flume water velocity ranged from 0.1 to 0.44 m/sec (0.3 to 1.4 ft/sec) during testing, depending on the light type being evaluated. Between 19 and 70 silver eels (320 to 720 mm [12.6 to 28.3 in.] in length) were used for each combination of light source, illumination level, and velocity evaluated. A deflection percentage (i.e., percent of eels entering the non-illuminated compartment) was calculated for each test to assess the effectiveness of the light types.

Deflection percentages ranged from 27% to 80% for incandescent light (six tests), 28 to 82 percent for fluorescent light (five tests), and 45% to 86% for strobe light (two tests). The results were statistically significant for all tests, with the exception of two incandescent light tests. Deflection rates for each light type typically were lower at the higher velocities evaluated. Also, the highest deflection rates observed for each light occurred at the highest illumination level. There were no statistical differences in deflection percentages among the three light types. It was concluded that each of the light devices had potential for successful field application given deployment configurations and illumination levels that allowed downstream migrants adequate time to respond before becoming entrained into an intake.

### **Laboratory Study – EPRI/University of Washington**

When juvenile salmon encounter a sudden decrease in ambient light intensity, they may become attracted to light. This response was investigated in a laboratory study by adapting age 0 Chinook salmon (*Oncorhynchus tshawytscha*) to a constant ambient light intensity followed by simultaneously reducing ambient light and producing a small spot of light at the center of the test tank (Puckett and Anderson 1988; EPRI 1990). The tests were based on the assumption that attraction to light would be proportional to the difference between perceived intensity of the stimulus light and the perceived intensity of the adaptation light.

Two-month-old juvenile Chinook salmon were used in the incandescent light tests. Fish were raised under artificial and natural light at the University of Washington hatchery and had an average length of 53 mm (2.0 in.). Experiments were conducted in an experimental tank, 2.4 by 0.9 m (8.0 by 3.0 ft). The tank was enclosed with black plastic to reduce outside light

interference. The tank was filled with 10°C (50°F) water, approximately 0.2 m (0.7 ft) deep. The lights used over the tank for adapting fish were two, 100-W incandescent bulbs, controlled by a rheostat. Stimulus light was a 200-, 40-, or 15-W incandescent bulb located inside a 0.18-m (0.6-ft) diameter, 0.6-m (2.0-ft) long, black stove pipe. The pipe created a cylinder of light through the water and a 0.27-m (0.9-ft) diameter spot of light at the bottom of the tank.

Fifteen salmon were placed in the experimental tank for 20 min to acclimate to the specified light intensity. The adaptation lights were then turned off and the stimulus light was turned on at the desired intensity. Fish behavior was recorded by a video camera for 2 min. Six replicates were completed for each of the light combinations. Video tapes were reviewed at slower speeds to determine specific behavior, and counts of salmon entering the light stimulus affected area. The tests examined the ratio of ambient light intensity ( $I_a$ ) to physical stimulus light intensity ( $I_s$ ). Maximum attraction to the stimulus light, as evidenced by the number of fish above the light spot, was observed when  $I_s = I_a$ . It was determined that fish responded to the ratio of  $I_a$  and  $I_s$ , not to the individual light intensities. Chinook actively avoided the light spot when  $I_s$  was 100 times  $I_a$  and attraction was greatest when  $I_a/I_s = 1$ . The study indicates that ambient light levels must be considered when attempting to guide fish with lights.

### **Laboratory Study – San Onofre Nuclear Generating Station**

Laboratory tests were conducted with overhead incandescent flood lights and strobe lights (described previously) to determine the potential for future application at the San Onofre Nuclear Generating Station (SONGS) in increasing the proportion of fish that enter a fish bypass and salvage system (Jahn and Herbinson 2000; see Chapter 12, Louvers). The laboratory tests were conducted in three phases from June to December 1995 using methods identical to those previously described for the strobe light tests. The steady light tests employed a 60-watt tungsten bulb used with a light blue filter (Kodak #80) to correct for the red spectrum.

Summer tests with steady light indicated no preference reaction by light-adapted anchovy. Dark-adapted fish, however, showed a statistically significant bias ( $p=0.013$ ) toward the north side of the apparatus. Compared to controls, dark-adapted fish showed an even greater attraction ( $p=0.018$ ) to the north side when the steady light stimulus was operating. The authors report that fish size, as well as day length and season, may have accounted for the difference in behavior in the summer and fall batches of fish.

Phase II tests used a simpler apparatus consisting of a round tank 3.7 m (12 ft) in diameter and 1.2 m (4 ft) deep. Water depth was approximately 0.9 m (3 ft). The tank was divided by two plastic curtains (46 cm [18 in.] apart). The curtains formed a 2.4-m (8-ft) long corridor. Fish were introduced into the tank at least 4 hrs before testing and were acclimated to relative darkness. For Phase II tests, topsmelt, kelp bass, California sheepshead, and walleye surfperch were tested in addition to anchovy. The tests involved switching on the light and video recording the number of fish on the lighted side. Tests lasted approximately 20 min, and fish counts were made at 5 min intervals for the duration of each test. After each test, fish were allowed to acclimate to relative darkness for at least one hour, then the light on the opposite side of the tank was switched on and the testing procedure continued.

The 141 responses displayed by the 109 Phase II multiple-species tests included: 67 attraction responses, 50 neutral responses, and 24 repulsion responses. Northern anchovy (*Engraulis mordax*), topsmelt (*Atherinops affinis*), Pacific sardine (*Sardinops sagax*), and white croaker

(*Genyonemus lineatus*) all showed a tendency to move toward the light. California sheephead (*Semicossyphus pulcher*) and kelp bass (*Paralabrax clathratus*) remained in the corridor. Walleye surfperch tended to move toward the dark side.

Phase III tests used the same apparatus and testing procedure as Phase II experiments, except that the light source used was three tungsten bulbs (with a total rating of 630 lumens). Only Pacific sardine, acquired in two batches, were used as test fish for Phase III. Equal numbers of fish were tested under each of the three light conditions. A voltage controller was used to obtain data at lower light levels. Nine to sixteen fish were used in each of the 66 test runs. Attraction to the lighted side was exhibited by 64 of the 66 fish (no change in the remaining 2).

### **Laboratory Study – South Dakota State University**

A laboratory test was conducted to evaluate the effects of strobe lights on plasma cortisol concentrations and avoidance behavior at South Dakota State University (Richard et al. 2007). Plasma cortisol concentrations were measured to determine stress levels, giving a better understanding of sensitivity to strobe lights. A broad range of fish taxa were used in this study including Centrarchidae (largemouth bass [*Micropterus salmoides*]), Cyprinidae (fathead minnow [*Pimephales promelas*]), Ictaluridae (channel catfish [*Ictalurus punctatus*]), Percidae (yellow perch [*Perca flavescens*]), and Salmonidae (Chinook salmon [*Oncorhynchus tshawytscha*]).

Six, 900-L circular tanks were used during plasma cortisol experiments, three for control groups and three for treatment groups. Treatment tanks were equipped with two cylindrical strobe lights each with a flash rate of 86 flashes per min, submerged 0.3 m (1.0 ft) below the water surface. Tanks were all covered with black polyethylene plastic to remove light transmission from the tanks. Two trials per species were conducted, totaling six replicates per treatment. Healthy fish were dip netted from holding tanks and randomly put into treatment or control tanks. For fathead minnow tests, 18 fish were added to each of the six tanks while four fish were added to each tank for the other species. Fish were allowed to acclimate to the test tanks for 24 hrs before the experiment began. Experiments were conducted in the dark between 2000 and 0600 hrs. Strobe lights ran for an hour, after which two to three individuals were randomly collected from the control and treatment tanks, anesthetized, and had blood samples taken. Additional fish were tested for an additional 6 hrs under control and treatment conditions. Blood samples were taken from the secondary group, put into a centrifuge, and plasma separated was stored at -80°C (-112°F) for analysis.

Avoidance behavior was evaluated in an experimental raceway under no flow conditions at a water temperature of 17 to 24°C (62.6 to 75.2°). Four strobe lights were installed at one end of the flume. Fish were introduced and allowed to acclimate to the raceway for 12 hrs in darkness. Each trial consisted of either fathead minnow (n = 20), channel catfish (n = 10), yellow perch (n = 10), largemouth bass (n = 10), or Chinook salmon (n = 6). Each trial consisted of paired control (lights off) and treatment (lights on) groups. The test started by turning the overhead lights on for 10 sec and determining where the fish were at the start of each trial. Then the overhead lights were turned off and fish were held for an additional 60 min. After the 60 min the overhead lights were turned back on and fish location recorded again. Fish were allowed to acclimate to the darkness for an additional 30 min and then the strobe lights were turned on for test groups. Fish location was recorded after 2 and 60 min in the same fashion as initial location



was recorded. Measurements from the strobe lights were taken in the video recordings and compared to species-specific plasma cortisol concentrations.

After 1-hr of strobe light exposure in test tanks, plasma cortisol levels were significantly higher in channel catfish, yellow perch and Chinook salmon compared to the control groups, while there was no significant differences between groups for fathead minnow and largemouth bass. Plasma cortisol concentrations were similar between treatment and control groups after 7-hrs of exposure.

During behavioral tests conducted in the raceway, treatment Chinook salmon, largemouth bass, and yellow perch displayed significant avoidance responses to strobe lights, moving a significant distance from them after 2 min compared to the control groups. After 60 min, treatment largemouth bass, channel catfish, yellow perch and Chinook salmon all exhibited avoidance responses to the strobe lights, moving a significant distance from the strobe lights compared to the control groups. The strobe lights had little influence on fathead minnows during either duration of time.



# 14

## SOUND

### Introduction

The focus of fish protection studies involving underwater sound technologies has been on the use of various types of low and high-frequency acoustic systems that have not previously been available for commercial use. High-frequency sound (>100 kHz; also referred to as ultrasound) has been shown to effectively repel members of the genus *Alosa* (American shad, alewife, and blueback herring) at several sites in the US (Ploskey et al. 1995; Dunning 1997; Consolidated Edison 1994). Other studies have not shown low-frequency sound (100 Hz to 20 kHz) to be consistently effective in repelling species such as largemouth bass (*Micropterus salmoides*), smallmouth bass (*Micropterus dolomieu*), yellow perch (*Perca flavescens*), walleye (*Sander vitreus*), rainbow trout (*Oncorhynchus mykiss*), gizzard shad (*Dorosoma cepedianum*), Atlantic herring (*Clupea harengus*), and bay anchovy (*Anchoa mitchilli*) (EPRI 1998b; Consolidated Edison 1994). Given the species-specific responses to different frequencies that have been evaluated and the variable results that often have been produced, additional research may be warranted at any sites where there is little or no data to indicate that a species of concern may respond to sound.

In the first practical application of infrasound (frequencies below 100 Hz) for repelling fish, Knudsen and colleagues (Knudsen et al. 1992, 1994) found a piston-type particle motion generator operating at 10 Hz to be effective in repelling Atlantic salmon (*Salmo salar*) smolts in a tank and in a small diversion channel. Following this success, there was a general belief in the scientific community that infrasound could represent an effective fish repellent since there was a physiological basis for understanding the response of fish to particle motion. The potential for currently available infrasound sources to effectively repel fish has been brought into question by the results of more recent studies. Given these results, it appears that infrasound sources need to be further developed and evaluated before they can be considered an available technology for application at cooling water intake structures (CWISs).

### Sound

The use of underwater sound to repel (and in some cases attract) fish has been investigated for over 50 years (Table 14-1). Over the last 20 years, the focus of fish passage and protection studies involving underwater sound has shifted from evaluations of low-frequency, mechanical sound generators (e.g., poppers, hammers, and fish drones) to evaluations of acoustic transducer systems that cover a wide range of frequencies and signal types.

Declassification of US Navy technologies has led to the commercial availability of underwater sound "projectors" with features that facilitate their use as fish deterrent technologies (e.g., size, cost, operating specifications, and reliability). Transducer-based systems are capable of producing a variety of sound signals with different waveforms over a wide range of frequencies and amplitudes.

Mechanical sound generators of various types have been developed or adapted from other uses. The hammer (also referred to as a fishpulser) is an impact device. It uses a spring-driven mass to excite the resonant modes of a structure that is in direct coupling with the water. It produces a high-energy low frequency sound, the duration of which is approximately 200 ms. The hammer can be easily modified (i.e., changing the end plate) to vary its output frequency. Impact sound generators have been evaluated for fish protection purposes in recent years. Earlier research had shown some promise for effective use of these devices, but impact sound generators generally have not been shown to effectively and consistently repel any species in actual field applications. At this time, it does not appear that impact sound generators have the potential for effective application at CWISSs.

Poppers are pneumatic devices that produce sound energy through the explosive release of air from a pressurized chamber. Poppers were developed for underwater exploration purposes. The fishdrone is a device that uses sonic vibrations to excite metallic structures. Frequencies ranging from 20 to 1,000 Hz can be generated without modifications to this device. The fishdrone can be operated continuously or intermittently and can produce regular or irregular pulses. Similar to impact sound generators, the effectiveness of poppers and fishdrones in repelling fish has been variable and these devices currently are not considered as viable technologies for reducing entrainment of fish at water intakes.

The effectiveness of transducer-based sound systems in eliciting avoidance behaviors from fish has also been variable. Low frequency systems (100 Hz to 20 kHz) have elicited responses from a wide range of species during cage tests and some pilot-scale field evaluations, but limited success has been achieved in field trials at water intakes. Based on the results of studies conducted with several freshwater fish species (Winchell et al. 1997; EPRI 1998b) and with juvenile salmonids (Ploskey et al. 1998b; Goetz et al. 1998), the use of low frequency sound systems does not appear to be a viable alternative for protecting fish at water intakes unless future research demonstrates otherwise. In contrast to low-frequency systems, high-frequency systems (>100 kHz) have been effective in eliciting avoidance responses from several clupeid species (shad and herring) during both cage test and field trials. Field studies conducted at the James A. Fitzpatrick Plant clearly demonstrated that when site-specific biological, environmental, and hydraulic characteristics were considered, a high-frequency sound system effectively repelled alewife near plant's cooling water intake (Dunning et al. 1992; Ross et al. 1993, 1996; Dunning 1997). A similar development process produced a high-frequency sound system for deterring blueback herring (*Alosa aestivalis*) at the Richard B. Russell Project.

**Table 14-1**  
**Summary of tests conducted with sound devices during field, cage, and laboratory studies**

| Site and Reference                                                                                  | Target / Abundant Species                                                                                          | Sound Device Tested                  | Frequencies Evaluated | General Study Conclusions                                                                                                      |
|-----------------------------------------------------------------------------------------------------|--------------------------------------------------------------------------------------------------------------------|--------------------------------------|-----------------------|--------------------------------------------------------------------------------------------------------------------------------|
| Doel Nuclear Power Plant (Belgium)<br>Maes et al. 2004                                              | herring, sprat, white bream, rainbow smelt, common sole, European flounder, and gobies                             | 20 FGS Mk II 30-600 sound projectors | 20 to 600 Hz          | Authors attribute greater avoidance behavior to species with swim bladders                                                     |
| James A. Fitzpatrick Power Plant<br>Dunning et al. 1992;<br>Ross et al. 1993, 1996;<br>Dunning 1997 | Alewife                                                                                                            | electric fish startle system         | 110 and 125 kHz       | Alewife impingement reduced by 85% while plant was in operation mode and 88% in non-operation mode.                            |
| Salem Generating Station<br>Taft et al. 1996;<br>Taft and Brown 1997                                | striped bass, spot, Atlantic croaker, bay anchovy, American shad, blueback herring, alewife, white perch, weakfish | hammer device                        | 0.1 to 145 kHz        | No signal consistently elicited avoidance responses. Deployment of a hybrid signal demonstrated some reduction in impingement. |
| Arthur Kill Generating Station<br>Consolidated Edison Company<br>1994                               | bay anchovy, bay anchovy, alewife, blueback herring, Atlantic herring, gizzard shad, and American shad             | narrow- and wide-beam transducers    | 18 and 198 Hz         | Strong deterrence in blueback herring and alewife; ineffective for gizzard shad, Atlantic herring, and bay anchovy             |

| <b>Site and Reference</b>                                                                                                                                 | <b>Target / Abundant Species</b>                                                                                     | <b>Sound Device Tested</b>  | <b>Frequencies Evaluated</b>                     | <b>General Study Conclusions</b>                                                                |
|-----------------------------------------------------------------------------------------------------------------------------------------------------------|----------------------------------------------------------------------------------------------------------------------|-----------------------------|--------------------------------------------------|-------------------------------------------------------------------------------------------------|
| Crescent and Visher Ferry Hydroelectric Project<br>Ross 1999;<br>Ross 2002;<br>FERC 2005;<br>Dunning and Gurshin 2012)                                    | blueback herring                                                                                                     | ultrasonic system           | 122 and 128 kHz                                  | Considerable number of fish were not deterred by the barrier                                    |
| Kingsford Hydroelectric Project<br>Winchell et al. 1997;<br>EPRI 1998a,b;<br>Michaud and Taft 2000                                                        | rainbow trout, walleye, yellow perch, golden shiner, bullhead, black crappie, sunfishes, largemouth, smallmouth bass | acoustic sound system       | 283, 600, 673, 2,000, 2,500, 2,990, and 5,500 Hz | Avoidance responses were species- and size-specific                                             |
| White Rapids Hydroelectric Project<br>Winchell et al. 1997;<br>EPRI 1998a, b;<br>Michaud and Taft 2000                                                    | rainbow trout, walleye, yellow perch, golden shiner, bullhead, black crappie, sunfishes, largemouth, smallmouth bass | acoustic sound system       | 283, 600, 673, 2,000, 2,500, 2,990, and 5,500 Hz | Avoidance responses were species- and size-specific                                             |
| Hiram M. Chittenden Locks<br>Ploskey et al. 1998b<br>Goetz et al. 1998<br>Goetz et al. 2001                                                               | coho salmon, Chinook salmon, sockeye salmon                                                                          | Model 220 transducers       | 300 to 400 Hz                                    | Barriers showed to be ineffective                                                               |
| Richard B. Russell Pumped Storage Project<br>Pickens 1992;<br>Ploskey et al. 1995;<br>Nestler et al. 1992, 1995a, 1995b, 1998;<br>Schilt and Ploskey 1997 | Blueback herring                                                                                                     | high-frequency sound system | 118 to 130 kHz                                   | The results of these tests demonstrated a substantial reduction in blueback herring entrainment |
| Pejepscot Hydroelectric Project<br>NDT et al. 1997                                                                                                        | alewife                                                                                                              |                             | 120 kHz                                          | The sound system was ineffective at increasing bypass                                           |

| Site and Reference                                                                                                                             | Target / Abundant Species                                        | Sound Device Tested               | Frequencies Evaluated           | General Study Conclusions                                                                                                                                                                                                                       |
|------------------------------------------------------------------------------------------------------------------------------------------------|------------------------------------------------------------------|-----------------------------------|---------------------------------|-------------------------------------------------------------------------------------------------------------------------------------------------------------------------------------------------------------------------------------------------|
| Racine Hydroelectric Plant<br>Loeffelman et al. 1991a, 1991b;<br>Klinect et al. 1992                                                           | basses,<br>catfishes, shad                                       | projectors                        | 120, 240,<br>360, and 720<br>Hz | Paired sound on/sound off experiments, 66% warmwater fish, 70% all other fish other than gizzard shad ( <i>Dorosoma cepedianum</i> ), and approximately 55% of the shad in the forebay approaching the sound field were repelled from the area. |
| Berrien Springs Hydroelectric Project and Buchanan Hydro Project<br>Loeffelman et al. 1991a, 1991b;<br>Klinect et al. 1992                     | steelhead trout and Chinook salmon                               | projectors                        | 120, 240,<br>360, and 720<br>Hz | 94% fewer steelhead and 81% fewer Chinook smolts were caught when the sound system was on                                                                                                                                                       |
| Georgiana Slough<br>Hanson Environmental, Inc., 1993;<br>SLDMWA and Hanson 1996;<br>Hanson et al. 1997                                         | Chinook salmon, juvenile striped bass, Sacramento splittail      | 10 to 12 Argotec Model 215 or 220 | 300 to 400<br>Hz                | Overall effectiveness varied with testing Phase.                                                                                                                                                                                                |
| Wilkins Slough Pumping Station<br>Cramer et al 1993                                                                                            | Chinook salmon                                                   | 10 to 12 Argotec Model 215 or 220 | 300 to 400<br>Hz                | Fyke net catches of fish naturally entering the forebay and fish monitoring data close to the sound barrier with sound on and off are reported to corroborate the results from the marked fish tests.                                           |
| Institute of Freshwater Ecology's River Laboratories, Frome River, Dorset, UK and Blantyre Hydroelectric Station<br>Nedwell and Turnpenny 1997 | Atlantic salmon and sea trout                                    | Bioacoustic Fish Fence            | 100 to 500<br>Hz                | Visual observations in 1996 indicated that nearly 100% of the smolts were diverted into the mill leat versus the main river channel                                                                                                             |
| Bonneville Dam<br>Ploskey et al. 1996                                                                                                          | Chinook salmon, coho salmon, sockeye salmon, and steelhead trout | 25 Argotec Model 215              | 300 to 400<br>Hz                | The sound array should to be ineffective                                                                                                                                                                                                        |

| Site and Reference                                                                                    | Target / Abundant Species                                                                      | Sound Device Tested                                                       | Frequencies Evaluated          | General Study Conclusions                                                                                                           |
|-------------------------------------------------------------------------------------------------------|------------------------------------------------------------------------------------------------|---------------------------------------------------------------------------|--------------------------------|-------------------------------------------------------------------------------------------------------------------------------------|
| Fort Halifax Hydroelectric Project<br>Environmental Consulting Services and Lakeside Engineering 1994 | Atlantic salmon, American shad, and alewife                                                    | 1)underwater alert system; 2)Fishfinder/depthsounder hydroacoustic system | 4 kHz; 192 kHz                 | 1)no discernible response from alewife was observed ;2)device produced a startle reaction in alewife                                |
| York Haven Hydroelectric Project<br>SWETS 1994                                                        | American shad                                                                                  | FishStartle                                                               | 100 and 150 kHz                | Exhibited avoidance responses but were not strong and did not displace fish a great distance away from the source                   |
| Vernon Hydroelectric Project<br>RMC and Sonalysts 1993                                                | American shad                                                                                  | FishStartle                                                               | 100 and 150 kHz                | Appeared to effectively move shad back and forth along the station intake structure                                                 |
| Hadley Falls Hydroelectric Project<br>Kynard and O'Leary 1990, 1993                                   | American shad                                                                                  | Wesmar SS-165 scanning sonar                                              | 161.9 kHz                      | Radio-tagged fish appeared to be initially repelled by the acoustic field, but would eventually pass through the barrier            |
| Lennox Generating Station                                                                             | alewife, yellow perch, pumpkinseed, black crappie, rock bass, rainbow trout, and golden shiner | fishdrone                                                                 | 27, 64, 99, and 153 Hz         | Results of testing with the fishdrone in the Lennox forebay indicated very little directional movement of fish away from the device |
| Seton Hydroelectric Station<br>McKinley & Patrick 1988a                                               | sockeye salmon                                                                                 | hammer device                                                             | 52 Hz                          | Sockeye salmon smolt catches in the Seton forebay were significantly reduced by the hammer device                                   |
| Allegheny Reservoir<br>Smith and Anderson 1984                                                        |                                                                                                | G34 transducer                                                            | 200 to 3,000 Hz                | The G34 transducer found to be ineffective for test fish.                                                                           |
| Arthur Kill Generating Station<br>Consolidated Edison Company 1994                                    | bay anchovy<br>alewife                                                                         | low and high-frequency sound systems                                      | 18 to 198 kHz;<br>75 to 500 Hz | Both species demonstrated avoidance responses                                                                                       |



| <b>Site and Reference</b>                                    | <b>Target / Abundant Species</b>                                                                      | <b>Sound Device Tested</b>              | <b>Frequencies Evaluated</b> | <b>General Study Conclusions</b>                                                                                                                                      |
|--------------------------------------------------------------|-------------------------------------------------------------------------------------------------------|-----------------------------------------|------------------------------|-----------------------------------------------------------------------------------------------------------------------------------------------------------------------|
| Cage Tests – NYPA and ESEERCO<br>NYPA et al. 1991            | alewife, striped bass, white perch, Atlantic tomcod, golden shiner, and spottail shiner               | hydroacoustics HLF-6; HX-29 transducers | <200Hz; 100 to 1000 Hz       | Avoidance responses were species- and size-specific                                                                                                                   |
| Pickering Nuclear Generating Station<br>Patrick et al. 1988a | alewife                                                                                               | hammer device                           |                              | Results indicated a consistent negative response from adult alewife to the hammer                                                                                     |
| Manimota Bay, Japan                                          |                                                                                                       | speaker system                          | 300 and 900 Hz               | Estimated to be approximately 70% effective; was difficult to assess because of low fish densities during the testing period.                                         |
| Laboratory Study - Kinectrics                                | American eels                                                                                         | sound generator                         | < 1,000 Hz                   | Results of the sound attraction trials reveal that both juvenile and adult eels were attracted toward the sound projector                                             |
| Annapolis Tidal Generation Station<br>Gibson and Myers 2002  | Atlantic silver side, Atlantic herring, Northern pipefish, blackspotted stickleback, blueback herring | model 3406 transducers                  | 122 and 128 kHz              | The results demonstrated that the sound barrier was partially effective for Alosa spp. At deterring fish from the tailrace, but was ineffective for all other species |

## ***Infrasound***

Research with sound deterrent systems generally has involved devices that transmit frequencies above 100 Hz. Several recent studies have focused on the ability of infrasound (frequencies less than 100 Hz) to repel fish based on the results of studies conducted with Atlantic salmon smolts (Knudsen et al. 1992, 1994). Extensive basic research on fish sensory systems has demonstrated that fish response to sound stimuli in the near field is probably more related to particle motion than acoustic pressure. Designs of infrasound sources have varied, but most have used some type of oscillating piston driven at frequencies less than 50 Hz. An alternative design, which has been evaluated with potamodromous fish and anadromous salmonids, generates frequencies between 10 and 60 Hz by driving water through a rotating valve with openings in it. The speed of rotation controls the frequency being emitted, and the flow rate controls the amplitude of the signal.

Until recently, research with sound deterrent systems generally has concentrated on frequencies above 100 Hz based on the assumption that observed fish responses were a result of stimulation of sensory organs to the acoustic pressure generated by sound sources. There is extensive literature on fish hearing. Various authors have presented models for fish audition that address the relative importance of the sensory receptors believed to be most important in "hearing" (e.g., the otolith organs, the lateral line and the air bladder), the importance of vectorial components (particle velocity, acceleration, and displacement) versus scalar components (acoustic pressure) in "sound perception" and behavioral response, and the ability of fish to determine the phase of the pressure signal relative to the particle displacement signal and thereby determine the direction of "sound" movement. It is becoming clear that, in the near field, fish response to "sound" is more related to particle motion than acoustic pressure.

Following the success of Knudsen et al. (1992, 1994), there was a general belief in the scientific community that infrasound could represent an effective fish repellent since there was a physiological basis for understanding the response of fish to particle motion. The potential for currently available infrasound sources to effectively repel fish has been brought into question by the results of more recent studies. Given these results, it appears that infrasound sources need to be further developed and evaluated before they can be considered for full-scale application.

Information on laboratory, cage, and field studies conducted with infrasound is presented in Table 14-2.

**Table 14-2**  
**Summary of tests conducted with infrasound devices during field, cage, and laboratory studies**

| Site and Reference                                                            | Target / Abundant Species                      | Infrasound Device Tested                                                | Frequencies Evaluated            | General Study Conclusions                                                                                           |
|-------------------------------------------------------------------------------|------------------------------------------------|-------------------------------------------------------------------------|----------------------------------|---------------------------------------------------------------------------------------------------------------------|
| McNary Dam<br>Johnson and Ploskey (1998)                                      | Pacific salmon                                 | Piston; PMG                                                             | <20 Hz                           | Inconclusive results due to limited visibility                                                                      |
| Sandvikselven River (Norway)<br>Knudsen et al. (1994)                         | Atlantic salmon                                | Piston                                                                  | 10 Hz and 150 Hz                 | 10 Hz revealed potential effectiveness as a deterrent, 150 Hz had no repelling affect                               |
| Roza<br>Amaral et al. 1998                                                    | Chinook salmon                                 | PMG                                                                     | 10–50 Hz                         | No response detected                                                                                                |
| Hiram M. Chittenden Locks<br>Ploskey et al. 1998b                             | Pacific salmon                                 | Piston; PMG                                                             | 10 Hz (piston)<br>10-50 Hz (PMG) | Piston caused mild avoidance in sub-yearling chinook salmon, PMG was ineffective at eliciting an avoidance response |
| Kingsford<br>Winchell et al. (1997)<br>EPRI (1990)<br>Michaud and Taft (2000) | freshwater spp                                 | PMG                                                                     | 5–60 Hz                          | Mild initial avoidance response for some species, ineffective in all others tested                                  |
| Rolfe Canal<br>Lakeside Engineering (1996)                                    | Atlantic salmon                                | 7 infrasound generators (air-driven pneumatic oscillators)              | 15 Hz                            | Mild avoidance behavior was observed                                                                                |
| Sommaroyhamn<br>Holand and Walso (1988)                                       | cod                                            | Low-frequency transducer (details on model or design were not reported) | ~30 Hz                           | Initial deterrent effect, reduced over time and exposure                                                            |
| PNNL<br>Mueller et al. (1999)                                                 | rainbow trout<br>Chinook salmon<br>brook trout | VDS opposable piston                                                    | 10 Hz                            | Initial avoidance response, significant habituation after fifth exposure                                            |
| PNNL<br>Mueller et al. (1998)                                                 | rainbow trout<br>Chinook salmon                | Opposable piston (Simrad); piston (EESCO)                               | 10-14 Hz (Simrad)                | Ineffective at eliciting a continuous flight and avoidance response, some initial                                   |

| Site and Reference                               | Target / Abundant Species       | Infrasound Device Tested | Frequencies Evaluated             | General Study Conclusions                                               |
|--------------------------------------------------|---------------------------------|--------------------------|-----------------------------------|-------------------------------------------------------------------------|
|                                                  |                                 | prototype)               | piston)<br>7 Hz<br>(EESCO piston) | responses were observed                                                 |
| Oregon State University<br>Knudsen et al. (1997) | Chinook salmon<br>rainbow trout | Piston                   | 10 Hz                             | Initial flight response decreasing to steady avoidance after repetition |
| University of Oslo<br>Knudsen et al. (1992)      | Atlantic salmon                 | Piston                   | 10 Hz                             | Initial avoidance response                                              |

## Case Studies – Sound – CWIS Field Trials

### ***Doel Nuclear Power Plant, Scheldt Estuary, Belgium***

The Doel nuclear power plant is located in the brackish water portion of the Scheldt Estuary in Belgium, an important nursery area for young-of-the-year marine and fresh water fish species. The plant has an offshore intake that withdraws 25.1 m<sup>3</sup>/sec (886.4 cfs) for cooling. Water travels to an onshore screenwell through a 540-m (1,771.7-ft) long pipe. Vertical traveling water screens with 4-mm (0.2-in.) square mesh collect fish and debris.

In 1997, an acoustic fish deterrent (AFD) system was installed to study its efficacy in reducing the number of fish entering the intake (Maes et al. 2004). A total of 20 FGS Mk II 30-600 sound projectors (Fish Guidance Systems LTD, Southampton, UK) were installed near the five 4.0 by 2.4 m<sup>2</sup> (43 by 25.8 ft<sup>2</sup>) intake openings. A signal generator was used to produce eight different sound signals in the 20 to 600 Hz range at a nominal output of 174 dB re: 1µPa. The signals were repeated once every 0.2 seconds.

Previous residence time studies with goldfish (*Carassius auratis*) using release/recapture techniques demonstrated that fish pass from the offshore intake to the onshore screenwell quickly (88% recaptured after 1 hour). Therefore, a day on/day off sampling strategy was employed to determine the efficacy of the AFD system. Preliminary results in 1997-98 indicated no significant reductions in fish passage. Therefore, the sound projectors were relocated and installed directly in the intake openings. Efficacy sampling occurred between October 1998 and October 2001.

Data were analyzed using a *t*-test of the log<sub>10</sub>-transformed data to identify statistically significant differences (P<0.05) in total numbers of fish caught during test (sound ON) and control (sound OFF) days. The minimum sample size used for analysis was a total of 50 individuals over each 48-hour on/off evaluation period. The reduction rate, R, was expressed as a percentage:  $R = 100 - 100 n_{\text{on}} n_{\text{off}}^{-1}$ , where  $n_{\text{off}}$  is the total catch of the control sample and  $n_{\text{on}}$  is the total catch of the test samples. In addition, the effects of salinity and temperature on species-specific efficacy were analyzed.

A total of 350,000 fish representing 24 families and 41 species was collected over the 3-year evaluation period. Total fish impingement decreased by 59.6% with the ADF in operation. The predominant fish collected represented several species of marine gobies; these species comprised 78% of the total catch. The differences in impingement between test and control was significant for nine species/taxa: herring, sprat, white bream (*Abramis bjoerkna*), rainbow smelt (*Osmerus eperlansus*), European seabass (*Dicentrarchus labrax*), yellow perch (*Perca fluviatilis*), common sole (*Solea solea*), European flounder (*Platichthys flesus*), and gobies of the genus *Pomatoschistus*. The AFD was particularly successful in reducing the number of herring impinged, with a total average reduction of 94.7%. The reduction of sprat averaged 87.9%, while that of Percidae averaged 51.2%. Reductions of *Stizostedion lucioperca*, *Limanda limanda*, pipefishes, sticklebacks, and mullets were not statistically significant. Multiple regression analyses of temperature and salinity showed no significant effect of these parameters on the percentage reduction in impingement in the nine species that reacted in a significant manner to the AFD.

The authors attribute species-specific differences in response to the AFD system, in part, to differences in hearing capabilities. Species with swim bladders showed clear avoidance of the system. Small movements of the swim bladder can be transmitted to the inner ear directly and via anatomical structures such as ducts. Such connections increase the fish's ability to detect sound. The authors also attribute AFD efficiency to fish size and associated swimming performance. The intake velocity at Doel is 0.52 m/sec (1.7 ft/sec), while ambient currents are 0.65 m/sec (2.1 ft/sec). It is logically suggested that larger fish can avoid the intake better than smaller ones. They offer examples of higher impingement of small-sized herring and sprat than other larger species when the AFD system was operating.

### **James A. Fitzpatrick Power Plant**

A multi-phase study approach was used to evaluate the use of a sound projection system to deter fish from the offshore intake of the James A. Fitzpatrick Power Plant (JAF) located on Lake Ontario near Oswego, New York (Dunning et al. 1992; Ross et al. 1993, 1996; Dunning 1997). Cooling water for JAF is withdrawn from Lake Ontario through a single submerged intake structure located about 300 m (980 ft) offshore. A series of traveling water screens are located onshore in a forebay to remove fish and debris that enter the intake. About 80% of the fish that are impinged annually at JAF are alewife (*Alosa pseudoharengus*). The estimated annual impingement of alewife has ranged from 66,124 to 522,672 fish. A phased approach was employed to develop a sonic deterrent system for reducing alewife entrainment. This approach included cage tests, a demonstration field evaluation, and full-scale system tests.

Results from cage tests demonstrated that alewife consistently avoided several high-frequency sounds at higher sound pressure levels. A strong avoidance response was observed during daytime hours with pulsed tones of 110 and 125 kHz at sound pressure levels of 175 and 180 dB, respectively, and with pulsed broadband sounds of 117 to 133 kHz at 157 dB. Following cage tests, a full-scale high-frequency system was developed and installed at the JAF intake. The system was evaluated during a short-term (10-day) demonstration test. The sound system encompassed (i.e., ensonified) the entire JAF intake at a minimum sound pressure level of 190 dB in a frequency band from 122 to 128 kHz. An 87% decrease in alewife impingement was observed with the plant at full power and the sound system operating. However, with the circulating water system in operation and the plant in a non-operating mode, impingement with the sound system operating decreased by only 27%. Lowered efficiency of the deterrent system during plant shutdown appeared to be caused by fish approaching from the non-ensonified backside of the intake due to changes in water temperatures between the shore and the intake.

Based on the results of the demonstration study, five additional transducers were placed on the backside of the intake structure to expand the area of coverage. An evaluation of the modified system indicated that it was effective, both when the plant was operating at full power and when the plant was shut down. Alewife impingement was reduced by about 85% during periods of full power and full cooling water flow and by about 88% when the plant was in a non-operating mode with only two intake pumps operating. Following the completion of the field studies, New York Power Authority recently installed and evaluated a permanent sound system at the JAF intake for minimizing alewife entrainment. The permanent system includes nine wide-beam transducers and no narrow-beam transducers. The final design of the sound system has been accepted by the New York State Department of Environmental Protection as the best technology

available (BTA) for reducing mortality of alewife and it has been incorporated into the project's NPDES permit.

### **Salem Generating Station**

Public Service Electric and Gas Company conducted a sound deterrent study at the Salem Generating Station located on Delaware Bay (Taft et al. 1996; Taft and Brown 1997). Salem has a flow capacity 140 m<sup>3</sup>/sec (4,956 cfs). Modified traveling screens and a fish return system are used to collect entrained fish and transfer them back to the river. The evaluation of the sound deterrent system was part of the station's permitting program and was being considered as a means to reduce impingement of selected target species on the traveling screens by repelling them from the intake. The Salem studies included both cage and intake testing. Response data collected from the cage tests were used to select sound signal parameters (frequencies, waveforms, pulse rates) for evaluation at the intake.

Species that were evaluated during cage tests in 1994 and 1998 included weakfish (*Cynoscion regalis*), spot (*Leiostomus xanthurus*), Atlantic croaker (*Micropogonias undulates*), bay anchovy (*Anchoa mitchilli*), American shad (*Alosa sapidissima*), blueback herring (*Alosa aestivalis*), alewife (*Alosa pseudoharengus*), white perch (*Morone americana*), and striped bass (*Morone saxatilis*). A wide-range of 1/2 octave sound signals that varied in frequency, amplitude, pulse duration, and duty cycle were evaluated during cage tests. The 1994 cage tests evaluated a wide range of frequencies extending from 0.1 to 145 kHz. The 1998 cage tests focused on a narrower range of frequencies (0.2 to 5.0 kHz) with the goal of refining a signal to deter fish other than the three *Alosa* species. Responses were evaluated by placing a group of fish in the test cage and exposing them to sound signals for a minimum of 30 seconds and up to 20 minutes. Fish behavior during ambient and sound exposure periods was observed using an underwater video system. Real-time observations of fish behavior were recorded during a test, and a secondary review of videotapes from each test was performed. Species-specific responses were produced over the frequency range evaluated. In general, weakfish, Atlantic croaker, and bay anchovy demonstrated various types of weak or moderate agitation or avoidance responses to at least one 1/2 octave frequency band, whereas spot, striped bass, and white perch exhibited weaker and less consistent responses. The *Alosa* species demonstrated repeated and strong avoidance to the 1/2 octave band centered at 121.8 kHz. These observations are consistent with results from previous studies that have evaluated the response of *Alosa* species with similar sound signals in the range of 120 to 130 kHz.

None of the signals evaluated during the 1994 or 1998 cage tests were found to consistently elicit avoidance responses from the other finfish RIS. While no sounds were very effective in changing behavior of non-*Alosa* species, it was hypothesized that there may be very different responses to sounds by fish in the cage tests versus fish tested at the CWIS where there is an open water environment in which fish are not handled. The lack of response in cage tests could potentially be attributed to factors such as stress due to handling, changes in behavior due to confinement in the test channel, or irregularities in the sound field caused by reflections.

Since no single signal showed a substantial degree of promise for deterring all of the non-*Alosa* species in cage tests, a hybrid signal was developed that included short segments of three low frequency signals. Two of the sounds were selected based on fish responses observed during the 1994 cage tests, and the third sound was developed in 1998 based on the logical argument that

fish are most likely to respond to sounds that are biologically meaningful to them. The selected signal consisted of 0.25-second periods of the 0.476 kHz 1/2 octave FM chirp, the 2.7 kHz 1/2 octave FM chirp, and another signal that was simulated to mimic sounds produced by Atlantic croaker. These three signals were played back-to-back (total pulse length of 0.75 seconds) with a 1.5 second sound-free interval between pulses.

ITC Model 3406 transducers were used to produce the ultrasonic signal during in situ testing at the Salem CWIS. The ITC-3406 transducer has a 45 degree beam width. Five of these transducers were deployed in an array designed to ensonify the area in front of the Unit 1 side of the CWIS. The transducers were mounted on three poles attached to every other pier at an elevation 11 ft (3.4 m) below mean tide. The axis of each transducer was oriented horizontally. On each pole, one transducer was mounted at 90 degrees relative to the face of the CWIS. On the Northernmost pole, a second transducer was mounted facing upstream at an angle of 22.5 degrees relative to the CWIS. A matching transducer was mounted on the southernmost pier oriented at the same angle in the downriver direction. This configuration was designed to achieve a minimum SPL of 154 dB //  $\mu\text{Pa}$  across the face of the intake based on acoustic modeling. Cage test results from 1994 indicated that an SPL of 154 dB (measured in the center of the cage) elicited strong avoidance responses in *Alosa* species.

Three G34 transducers were used to transmit the hybrid low-frequency signal at the CWIS. These omni-directional transducers were placed in the same three locations as the ultrasonic transducers, but only one transducer was mounted on each pole. All three transducers were mounted at an elevation 10 ft (3.0 m) below mean tide. This configuration was designed to achieve a minimum SPL of 165 dB across the face of the intake based on acoustic modeling. This sound pressure level appeared to elicit avoidance responses for most species during some of the 1994 cage tests. The 1998 cage tests found few responses for weakfish or bay anchovy even though SPLs were comparable to those that were tested in 1994.

Testing was conducted during the period from July 16 through August 23. During this period, 84 paired test/control experiments were conducted. Each of these sound-off and sound-on pairs is referred to as a block. Each block consisted of one 3-hour “on” period and one 3-hour “off” period. Therefore, the total test block was 6 hours in duration. During a single 24-hr period, up to four paired experiments could be conducted. The four daily blocks were scheduled such that tests were conducted at dawn, day, dusk, and night.

The study design called for testing only low frequency sound throughout the summer. High frequency sounds were thought to be effective primarily for *Alosa*, and they were not expected to be present in adequate numbers until the fall. By August 15, 1998, it was apparent that the effectiveness of the low frequency sound was far less than the targeted 50%. Under this circumstance, demonstrating statistical significance was not possible under the current study design. Given this limitation, it was decided that subsequent summer testing would explore combined operation of the high frequency and low frequency deterrent systems.

Testing was also conducted during the period October 10 through December 2. During this period, 120 paired test/control experiments were conducted. Both low and high frequency sounds were tested throughout the period. The same basic experimental design was used in the fall as during the summer, i.e., randomized 3-hour “on” and 3-hour “off.”



During the summer test periods, 22,960 fish representing 33 taxa were collected. Of these, 12,117 were collected in sound-off tests while 10,843 were collected during sound-on tests. The eight most abundant species — weakfish, blue crab, hogchoker (*Trinectes maculatus*), Atlantic croaker, striped bass, striped cusk-eel (*Ophidion marginatum*), bay anchovy, and Atlantic silverside (*Menidia menidia*) — accounted for 22,708 individuals or 98.9% of the total collected. Remaining species were not collected in sufficient numbers to calculate meaningful Effectiveness Indices.

During the fall control and test periods, 23,113 fish representing 48 taxa were collected. Of these, 11,198 were collected in sound-off tests while 11,915 were collected during sound-on tests. Blue crab, Atlantic croaker, blueback herring, hogchoker, striped cusk-eel, bay anchovy, Atlantic silverside, alewife, white perch, weakfish, and striped bass accounted for 22,481 individuals or 96.9% of the total collected. All other species were not collected in sufficient numbers to calculate meaningful Effectiveness Indices.

Sound deterrents were found to reduce bay anchovy impingement by approximately 30 to 35% during the summer low frequency sound period and during the fall. Of these two test periods, only the fall test period (when both low and ultrasonic frequencies were used) was statistically significant. While results for the later summer test period indicated even higher effectiveness levels (and marginal statistical significance), the wide bootstrap confidence intervals suggest that the results are not significantly different than those obtained during the earlier summer and fall test periods.

A statistically significant reduction in the impingement of Atlantic silverside was observed during the fall. During sound-on periods, the impingement rate of Atlantic silverside was approximately 20% lower than it was during sound-off periods. A statistically significant increase in the impingement of blue crab was observed during the fall. During sound-on periods, the impingement rate of blue crab was approximately 20 to 25% higher than it was during sound-off periods. Results for the *Alosa* species were equivocal. Alewife demonstrated a positive, but non-significant, repulsion. Blueback herring results were also positive, with one of the three analyses indicating a statistically significant effect (i.e., reduced entrainment with sound on). There was no evidence of residual (carry-over) effects within the sampling design, i.e., the effect of one test did not influence subsequent tests.

### **Arthur Kill Generating Station**

High-frequency sound was examined as a fish deterrent during studies conducted at the Arthur Kill Station located on Staten Island in New York (Consolidated Edison Company 1994). Cage tests examining the responses of bay anchovy (*Anchoa mitchilli*) to high- and low-frequency sound also were conducted during this study, and are discussed in the section on controlled experiments with sound. The Arthur Kill Station has two fossil fuel units (Units 20 and 30). Unit 20 is rated at 335 and Unit 30 at 491 MW. Both units are serviced by a once-through cooling water system with a flow capacity of 15.4 m<sup>3</sup>/sec (544 cfs) for Unit 20 and 13.2 m<sup>3</sup>/sec (468 cfs) for Unit 30. Cooling water passes through eight intake bays, each equipped with dual-flow traveling screens. High-frequency sound transducers were mounted on four of the station's eight intake bays. The sound system comprised both narrow- and wide-beam transducers. The sound system was evaluated for its ability to repel bay anchovy, alewife (*Alosa pseudoharengus*), blueback herring (*Alosa aestivalis*), Atlantic herring (*Clupea harengus*), gizzard shad (*Dorosoma*

*cepedianum*), and (*Alosa sapidissima*). Based on the seasonal abundance of each species, tests were conducted during November and December in 1993 and during April and May in 1994.

The effectiveness of the sound system was evaluated by comparing the number of fish impinged on the traveling screens of the intakes on which the transducers were installed during sound-off and sound-on periods. Treatment and control periods were 24 hours in duration for tests targeting each species except alewife. Because some alewife were capable of residing within the intake for several hours, treatment and control periods were extended to 48 hours for tests with this species to minimize bias associated with delayed impingement. Fish collections from the intake screens generally were conducted every 2 hours during each treatment and control period.

Impingement rates from sound-on and -off periods indicated strong deterrence of blueback herring. The impingement rate of blueback herring over the course of the study was more than 20 times higher during control periods than it was during treatment periods. Impingement rates declined immediately when the sound was activated, and there were rapid increases when it was de-activated. Alewife impingement rates demonstrated a similar but less distinct pattern of reduced and increased impingement when the sound system was activated and de-activated. American shad were excluded less effectively than blueback or alewife but showed an overall impingement rate three times higher when the system was off than when it was on. The sound system was ineffective in reducing impingement of gizzard shad, Atlantic herring, and bay anchovy.

## **Case Studies – Sound – Other Applications**

### ***Crescent and Visher Ferry Hydroelectric Project***

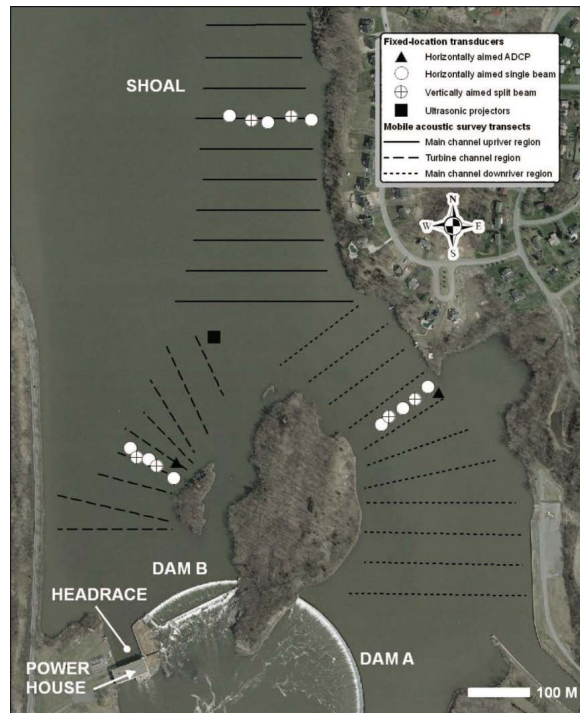
High-frequency sound was evaluated as a means to guide outmigrating blueback herring (*Alosa aestivalis*) (juveniles and adults) away from turbine intakes and toward bypasses at the Crescent and Visher Ferry Hydroelectric Projects located on the Mohawk River in New York (Ross 1999). Field studies were conducted at each site during 1997 and 1998, with additional testing conducted in 2001, 2002, and 2008 at Crescent (Dunning and Gurshin 2012). The Crescent Project is the lower most project on the Mohawk River, located 4.8 km (3 mi) upstream from the Mohawk's confluence with the Hudson River. The Crescent project has two dams that are separated by a rock island and that have total length of 438 m (1,436 ft). The Crescent powerhouse has two Kaplan and two Francis turbines that each generate about 3 MW. The operating head for the project is about 8.4 m (27.5 ft) and the maximum flow at rated output is about (42.5 m<sup>3</sup>/sec [1,500 cfs]) per unit. The Visher Ferry Project is located about 16 km (10 mi) upstream of the Crescent Project. The Visher Ferry Project has a 585 m (1,919 ft) long dam and a powerhouse with four turbines that are identical to the units at Crescent.

The high-frequency sound systems (described below) that were evaluated at each project were designed to deflect downstream-migrating fish away from the headraces of each powerhouse and toward bypasses located on the dams. The bypasses were created by removing a small section of flashboards from each dam at the periphery of effective sound field. Hydroacoustic techniques were used to monitor the distributions of blueback herring schools as they approached each project. Fish movement was evaluated with sound on and off with the bypasses open and closed (i.e., with and without the flashboard sections in place). Preliminary assessment of the hydroacoustic data indicate that the high-frequency sound systems employed at both projects

were effective in deflecting fish toward the bypasses. Additionally, preliminary observations suggested that the behavior of adult and juvenile blueback herring differed, with adults traveling deeper in the water column. This observation has implications with respect to the location and depth of a bypass. Also, it was determined that preventing outmigrants from entering the entraining flow to a powerhouse (i.e., deflecting them away from a path that would take them toward an intake) was important to successful guidance.

An additional field study was conducted in 2008 to determine the effectiveness of ultrasonic barriers on deterring juvenile blueback herring from entering the turbine channel of the Crescent Project (Dunning and Gurshin 2012).

The ultrasonic system installed at Crescent was designed to create an avoidance barrier, diverting fish to the main channel. To accomplish this, the system was designed to output a band-limited ultrasound pressure level between 122 and 128 kHz at an ambient sound pressure level of at least 163 dB from surface to bottom and across the entrance of the turbine channel. An array of eight projectors was placed in the turbine channel, 487 m (1,597.8 ft) from the tailrace (Figure 14-1). This location was selected to avoid higher velocity flows, assuming higher flows would make it difficult for juvenile blueback herring to avoid entrainment.



**Figure 14-1**  
**Locations of eight ultrasonic (122–128 kHz) projectors, a horizontally aimed, 500-kHz acoustic Doppler current profilers (ADCPs), 420-kHz, horizontally-aimed single-beam transducers and vertically-aimed split-beam transducers (mounted from the river bottom), and mobile hydroacoustic survey transects used for the 2008 evaluation of high-frequency sound at the Crescent Project (Dunning and Gurshin 2012).**

The ultrasonic barrier was on during the entire of the entire 2008 study period (i.e., sound-off periods were not incorporated into the experimental design). This was done because:

- there was only limited information on the temporal pattern of downriver migration by juvenile blueback herring in the Mohawk River;
- state and federal regulatory agencies wanted confirmation that most juvenile blueback herring migrated downriver through the main channel rather than through the turbine channel, regardless of the reason for this behavior; and
- it seemed unlikely that most juvenile blueback herring would migrate downriver through the main channel under existing conditions because more water generally flows through the turbine channel than through the main channel due to power generation.

Hydroacoustic sampling techniques were used to monitor movements of blueback herring through the main channel. Fixed-monitoring stations, located upstream and downstream of the ultrasonic array, continuously tracking movement passed the array. Mobile hydroacoustics supplemented fixed stations, providing spatial distribution of fish in the study area and helped to confirm the presence and the relative abundance of juvenile blueback herring that were seen in and near the Crescent headrace.

Fish sampling of pelagic habitats was conducted using a 4.8-m (15.75-ft) diameter 12-mm (0.5-in.) mesh cast net to monitor species presence in the testing area. The fish sampling effort was dominated by blueback herring, accounting for 98% of the sample. The average length was 73 mm (2.9 in.) ranging from 53 to 88 mm (2.1 to 3.5 in.). Mobile hydroacoustics indicated that a considerable number of fish were using the turbine channel (i.e., they were not deterred by the ultrasonic barrier). Fixed hydroacoustic results demonstrated an increase in the proportion of fish at the downstream section of the main channel from 11.5 to 31.1%. This corresponds to a decrease in the proportion of fish entering the turbine channel from 88.5 to 68.7%, resulting in a diversion rate of 23%.

### ***Kingsford Hydroelectric Project***

An acoustic sound system was evaluated for its ability to repel potamodromous fishes during cage tests conducted at the Kingsford Hydroelectric Project located on the Menominee River (Winchell et al. 1997; EPRI 1998a, b; Michaud and Taft 2000). Several light devices and an infrasound generator also were evaluated during this study. A description of the study design and methods was provided previously in the section on strobe lights. Behavioral stimuli that elicited avoidance responses during cage tests were considered for evaluation during field studies conducted at the White Rapid Hydroelectric Project (discussed previously). Species that were evaluated for response to acoustic signals included rainbow trout (*Oncorhynchus mykiss*), walleye (*Sander vitreus*), yellow perch (*Perca flavescens*), golden shiner (*Notemigonus crysoleucas*), bullhead (*Ameiurus* spp.), black crappie (*Pomoxis nigromaculatus*), sunfishes (*Lepomis* spp.), and largemouth (*Micropterus salmoides*) and smallmouth bass (*Micropterus dolomieu*).

With the exception of golden shiner and black crappie, each species demonstrated some level of avoidance to various acoustic signals. Avoidance reactions of bullhead, sunfish, and smallmouth bass were classified as weak. Avoidance behaviors exhibited by rainbow trout, walleye, yellow perch, and largemouth bass were classified as moderate. The center frequency of signals that

produced avoidance reactions from rainbow trout was 6,000 Hz. Center frequencies for signals that elicited avoidance from walleye included 566, 673, 1,350, and 2,990 Hz. Effective signals for yellow perch were centered at 673, 953, 1,000, and 2,000 Hz. Largemouth bass demonstrated avoidance to signals with center frequencies of 283, 600, 673, 2,000, 2,500, 2,990, and 5,500 Hz. Based on these results, sound signals with center frequencies of 673, 2,000, 2,990, and 5,000 Hz were selected for evaluation during field studies at the White Rapids Project.

### ***White Rapids Hydroelectric Project***

An acoustic sound system was evaluated as a fish deterrent during field tests at the White Rapids Hydroelectric Project located on the Menominee River, bordering Wisconsin and the upper peninsula of Michigan (Winchell et al. 1997; EPRI 1998a, b; Michaud and Taft 2000). Strobe lights and an air bubble curtain also were evaluated during this study and are discussed in their respective sections. A description of sampling design and methods is provided in the strobe light section. Acoustic transducers and strobe lights were deployed on the trash racks of Unit 1 in attempts to repel fish from the intake. The number of fish collected in full-flow tailrace nets that sampled the entire discharge of Unit 1 was used to estimate fish entrainment during periods when sound and either lights or the air curtain were operated together or alone and during control periods (i.e., no devices operating). Tests were conducted during sampling periods in July, September, and October. Statistical analysis of entrainment data from treatment and control periods showed that the signals tested, whether transmitted alone or in combination with strobe light or an air bubble curtain, did not produce a significant reduction in total fish entrainment through Unit 1. Similarly, significant reductions in entrainment were not detected when data were analyzed by species, family, and size class.

### ***Hiram M. Chittenden Locks***

The response of Pacific salmon smolts to underwater sound was evaluated during cage tests conducted at the Hiram M. Chittenden Locks located in Seattle, Washington (Ploskey et al. 1998b). Strobe lights and infrasound generators also were evaluated during this study. Tests with each of these devices is discussed in their respective sections. The evaluation of behavioral devices conducted at the Chittenden locks was designed to identify stimuli that have potential for guiding fish to bypasses or collection systems at hydropower projects. Sound tests were conducted with an EESCO model 215 transducer emitting 300 and 400 Hz blended signals (crescendos). Test fish included sub-yearling Chinook (*Oncorhynchus tshawytscha*), coho (*Oncorhynchus kisutch*), and sockeye salmon (*Oncorhynchus nerka*). The transducer was placed 0.3 m (1 ft) from the end of the net pen, which was 4 m (13 ft) long with a diameter of 1.5 m (4.9 ft). The net pen was oriented horizontally in the water column. Groups of 10 to 25 fish were placed in the net pen 30 to 60 minutes before a test was conducted. Fish exposed to sound signals during 30 to 60 second stimulation periods and during a prolonged period of 5 to 10 minutes. Control periods were conducted in a similar manner as treatment periods. Fish behavior was monitored using four underwater cameras mounted on the net pen at 1-m (3.3-ft) intervals. Based on the results of a rigorous statistical analysis, none of the species demonstrated any discernible responses to the 300 and 400 Hz crescendos.

A study was conducted in the spring of 1997 at Hiram M. Chittenden Locks to evaluate the efficacy of a low-frequency sound array to guide juvenile salmonids away from a lock and

navigation channel (Goetz et al. 1998). The entrance to the lock chamber is 45.7 m (149.9 ft) long and 24.4 m (80.0 ft) wide and averages 11.6 m (38.1 ft) in depth. The chamber itself is 243.9 m (800.2 ft) long, 24.4 m (80.0 ft) wide, and 15.2 m (50.0 ft) deep. It is divided into two half-chambers (upper and lower) by an intermediate gate. The intake to the system is a pair of 4.3 m (14.1 ft) by 4.9 m (16.1 ft) culverts located upstream of the miter gates. The culverts connect to 4.3 m (14.1 ft) by 4.9 m (16.1 ft) conduits that run longitudinally along each side of the lock. Flow through each conduit is gravity fed and controlled by three independently operating stony gate valves. A surface overflow weir located on a spillway adjacent to the locks was installed to provide passage for salmon smolts.

The sound system that was evaluated consisted of EESCO Model 220 transducers that generated 300 and 400 Hz crescendo sounds. Two transducers were installed at the entrance to the large lock chamber. Four daily treatments (4-hour periods) of sound-on sound-off were determined by a randomized block design. The performance of the EESCO sound array was evaluated in two ways. First, smolt passage into the lock during sound on treatments was compared to smolt passage during sound-off treatments. Second, passage rates of smolts over the spillway overflow weir surface collector during sound-on treatments and sound-off treatments were collected by above water video cameras. Additionally, testing was conducted in a net pen installed in Salmon Bay adjacent to the locks. Smolt density in the lock chamber was estimated using a splitbeam mobile hydroacoustics with species verification using a deep-draft purse seine. Surveys were conducted once per treatment.

The results of the two sample t-test concluded that there was no significant difference in the mean density of smolts between sound treatments. The acoustic average smolt density varied by period and day. Species composition was verified by purse seine two to three times per week. A total of 340 fill events (lockages) were performed during the 29 days of the study. Mobile hydroacoustic surveys were performed during 106 of the 116 planned surveys (58 sound-on 58 sound-off). The number of hours of videotaped overflow weir counts ranged from 8 to 17 hours per day. Density of smolts with the transducers on was 0.046 smolts/m<sup>3</sup> and was 0.057 smolts/m<sup>3</sup> with the transducers switched off. Analysis of variance (ANOVA) was used to evaluate other factors that may have confounded the analysis of treatment effects. The ANOVA failed to detect a significant difference among additional factors, including survey periods (time of day), periods of spill, and periods of varying up-lockages. The final week of sound-on sound-off treatments also was analyzed separately because of an apparent change in signal frequency which may have influenced density estimates. No evidence of a change in frequency to the sound array was discovered. The sound treatment did not impact the density of salmonids measured within the lock chamber. Also, testing of the EESCO transducer in the net pen produced similar results to the field studies. The 300 and 400 Hz sounds failed to elicit startle responses or directional avoidance by hatchery sub-yearling coho (*Oncorhynchus kisutch*) and Chinook salmon (*Oncorhynchus tshawytscha*) or by wild yearling sockeye salmon (*Oncorhynchus nerka*).

An open water study evaluated the response of Chinook and sockeye salmon smolts to a low frequency underwater sound transducer (Goetz et al 2001). The objective of the study was to determine the efficacy of the sound transducers at guiding the smolts away from the lock and navigation channel. The sound system deployed consisted of two 104.5-kg traducers that were anchored at the bottom of the channel at the entrance of the large lock chamber 24.4 m apart. These traducers emitted 300 and 400 Hz blended signals (crescendos) with maximum source

levels at 170-180 dB//1  $\mu$ Pa at 1 m (3.3 ft). Testing lasted 29 days with four daily treatments of sound/on and sound/off from 0530 to 2130. Smolt densities in the lock chamber were estimated using acoustic data collected by a spilt-beam echo sounder. Species composition was verified by purse seining. As with cage tests, the sound system proved to be ineffective at guiding salmon smolts, not impacting the density of salmoids in the lock chamber.

### **Richard B. Russell Pumped Storage Project**

High-frequency sound was evaluated as a fish protection measure for reducing blueback herring (*Alosa aestivalis*) entrainment during pumpback operation at the Richard B. Russell Pumped Storage Project (RBR) located on the Savannah River between South Carolina and Georgia (Pickens 1992; Ploskey et al. 1995; Nestler et al. 1992, 1995a, 1995b, 1998; Schilt and Ploskey 1997). The RBR project has four reversible turbines and four conventional turbines with a combined generating capacity of 640 MW and total discharge of 1,700 m<sup>3</sup>/sec (60,000 cfs). The combined pumpback flow capacity is about 850 m<sup>3</sup>/sec (30,000 cfs). A series of studies was conducted at RBR to develop an effective sound deterrent. Initial studies examined blueback herring response to low- and high-frequency sound signals during net pen tests (Nestler et al. 1992). Follow-up studies with a high-frequency sound system were conducted in the project tailrace using hydroacoustic techniques to assess fish densities during sound-on and -off periods (Pickens 1992). The most recent studies evaluated entrainment rates of blueback herring during pumpback operations with the sound on and off (Ploskey et al. 1995; Nestler 1995a, 1995b, 1998).

Net pen tests with blueback were conducted in a cove of RBR Lake. The effect of low-and high-frequency sound signals on fish distribution in the pens was used to determine the potential for a particular frequency to deter fish. Blueback herring did not demonstrate a considerable or consistent response to low-frequency sound (<1,000 Hz). Avoidance responses were greatest to signals with frequencies between 110 to 140 kHz at sound pressure levels greater than 190 dB //  $\mu$ Pa. Subsequently, sounds in this frequency range were evaluated during tailrace tests. The tailrace study assessed sound deterrent effectiveness by comparing hydroacoustic surveys along twelve transects during sound-on and -off sampling periods. Results indicated that high-frequency sound reduced fish densities near the RBR tailwater. Hydroacoustic surveys showed a maximum distance of effectiveness from about 24 to 50 m (80 to 165 ft) from the dam at a source level of 187 dB //  $\mu$ Pa and a maximum effectiveness distance between 50 and 75 m (165 and 250 ft) at a source level of 200 dB //  $\mu$ Pa.

Following net pen and tailrace studies, tests with an improved system configuration were conducted during pumpback operations. The transducers produced signal bursts (118 to 130 kHz) of 5 ms every 50 ms at a sound pressure of 200 to 212 dB. They were fired sequentially and signal frequency was automatically changed by 10% every 15 minutes to minimize acclimation. Netting of entrained fish was performed during random periods with the sound system operating and not operating. A 55 m (180.5 ft) long net in the forebay was used to sample the entire volume of the pumpback jet. Additionally, acoustic counts of fish passage into all afterbay draft tubes during pumpback operation were made using fixed-aspect hydroacoustic techniques. Pumpback net catches were regressed upon acoustic counts from afterbay draft tubes of the same unit to derive an equation for predicting passage through unnetted units from the acoustic counts.

The results of these tests demonstrated a substantial reduction in blueback herring entrainment into the units during pumpback when the sound system was operating; approximately 56% fewer fish were entrained with the sound system on. Based on the results from the extensive testing program, the high-frequency sound system has been installed at the RBR project as a part of an integrated fish protection system, which also includes the use of bar rack overlays and high-pressure sodium lights.

### ***Pejepscot Hydroelectric Project***

A high-frequency sound deterrent system was evaluated as part of the downstream fish passage facilities employed at the Pejepscot Hydroelectric Project located on the Androscoggin River in Maine (NDT et al. 1997). The passage facilities at Pejepscot were installed to pass alewife (*Alosa pseudoharengus*) during periods of outmigration. The project has two adjacent powerhouses identified as A and B. Powerhouse A has a vertical Kaplan turbine rated at 12.5 MW, and Powerhouse B has three horizontal Francis turbines, two rated at 500 kW and one rated at 600 kW. The Kaplan unit has a flow capacity of 201 m<sup>3</sup>/sec (7,100 cfs) and the three Francis units have a combined capacity of about 28 m<sup>3</sup>/sec (1,000 cfs). The Kaplan turbine operates near continuously because of its large flow capacity. The three Francis units usually are operated during periods of spring run-off when the capacity of the Kaplan unit is exceeded. The downstream fish passage facilities comprise two bypasses with adjustable weirs (referred to as north and south bypasses) located on either side of the Powerhouse A trash rack. Steel pipes transport fish from the bypass to the project's tailrace. The sound deterrent system was installed as a means to reduce alewife entrainment into the turbine intake and increase the use of the bypasses. The system included three transducers operated at a frequency of 120 kHz.

The sound system was evaluated as a secondary component of the project's downstream passage facilities and its effectiveness was assessed relative to bypass efficiencies that were calculated from mark-recapture studies conducted in 1996. One to three high-frequency transducers were operated during bypass efficiency tests. Releases of marked fish were conducted with one transducer located near one of the bypasses. During these tests the recapture rates of marked fish were compared between the two bypasses (i.e., one without sound and one with sound). Tests also were conducted with the three transducers placed at the center of intake trash rack. During these tests either one or all three transducers were operating. When a transducer was located and operated near one of the bypasses, more fish were collected in the bypass on the opposite side of the intake. During these tests, the number of fish collected in the bypass without sound was between 50 and 90% lower than the bypass with sound. The bypass efficiency of marked fish ranged from 14.9 to 19.0%, with three transducers operating at the center of the intake and between 13.0 and 40.9% with one transducer operating. During a test without sound, the bypass efficiency of marked fish was 23.9%. These results indicate that the sound system was ineffective at increasing bypass use in the configuration that it was tested. Conversely, the results from tests with the transducers located near one of the bypasses demonstrated that the high-frequency system did repel alewife.

### ***Racine Hydroelectric Plant***

Studies conducted by American Electric Power (AEP) at its Racine Hydroelectric Plant on the Ohio River, near Pomeroy, Ohio, indicated that fish were repelled by a low frequency (<1 kHz), high amplitude (approximately 150 dB //  $\mu$ Pa) sound produced by a submerged generator in the



intake to the project's horizontal Kaplan units (Loeffelman et al. 1991a, 1991b; Klinect et al. 1992). Coincident side-scan sonar observations of forebay fish distributions and sound measurements suggested that the sound was influencing fish distribution and limiting entrainment of fish into the turbine. Sound frequencies that were measured when the units were operating were predominantly in the 120, 240, 360, and 720 Hz frequencies, with harmonics of 60 Hz. Based on the findings, a sound system was developed and tested at Racine in fall of 1987.

Guidance signals used in the fall testing period were created from characteristics of sounds produced by fish. Frequencies used by fish were determined by creating a listening chamber. The chamber consisted of a large plastic bag suspended from a cross-arm. Water and fish were introduced into the bag, and recordings were made using a hydrophone. The fish were also monitored by video to ensure that the sounds being recorded were sounds generated by fish and not made by incidental bumps or splashes. The fishes' sounds were recorded in a portable recording studio (that can be transported to a test site) and technically analyzed for such features as frequency content, duration, and amplitude. The most sensitive portion of the fishes' hearing was determined, and a new signal was synthesized that duplicated these frequencies. Recorded frequencies were then analyzed and synthesized using a wave form generator. Two Argotech sound projector models were used to produce the sound pressure for the field tests. The model 219 had a sound pressure level rating of 160 dB //  $\mu$ Pa at a frequency of 100 Hz. The model 220 was rated at 180 dB //  $\mu$ Pa at a frequency of 100 Hz. In paired sound on/sound off experiments, 66% of all the warmwater fish, 70% of the fish other than gizzard shad (*Dorosoma cepedianum*) (e.g., basses and catfish), and approximately 55% of the shad in the forebay approaching the sound field were repelled from the area.

### **Berrien Springs Hydroelectric Project and Buchanan Hydro Project**

Using sound systems similar to the one evaluated at Racine, testing was conducted at Berrien Springs Hydroelectric Project on the St. Joseph River in southwestern Michigan and Buchanan Hydro Plant (located 19.3 km [12 mi] from Berrien Springs). Tests conducted at each facility were designed to target specific fish communities. Studies at Racine had focused on warm water game fish, whereas cold water game fish, like steelhead trout (*Oncorhynchus mykiss*) and Chinook salmon (*Oncorhynchus tshawytscha*), were the target at Berrien Springs and Buchanan.

Initial studies conducted at the Berrien Springs Hydroelectric Project showed that adult steelhead trout were reluctant to pass up a fish ladder when sounds "tuned" from that species were projected into the second pool of the ladder (Loeffelman et al. 1991a, 1991b; Klinect et al. 1992). Seventy-two percent fewer adult steelhead ascended the ladder when the sound was on compared to when the sound was off. Counts of adult Chinook salmon and total fish were not statistically influenced by the sound when counts of fish with sound on and off were compared. However, the authors concluded that the effect on Chinook salmon might have been greater if a higher sound pressure had been used, particularly because of the masking effect of the noise inside the concrete fish ladder. The trials did show, however, that customizing the signal for Chinook was important to overcome the natural stimuli for their movement. Statistical analyses of the data showed that salmon were influenced ( $p < 0.1$ ) by water temperature when the steelhead trout signal was on but not when the new signal developed for the Chinook salmon was on.

In 1990, the tuning process was tested as a method to divert steelhead trout and Chinook salmon smolts from the headrace of the Buchanan Hydroelectric Project (Loeffelman et al. 1991a, 1991b; Klinect et al. 1992). Several signals were synthesized based on sounds recorded from the two species of smolts. The response of fish to these signals was assessed in an observation chamber to determine which signal was most effective in repelling each species. Signals were customized to best fit the hearing abilities of the fish, and other signals were designed to be less precisely tuned to the fish to evaluate AEP's theory on signal development. Signals believed to be the best customized to their hearing abilities were most effective in changing the fishes' swimming behavior. Prior to outplanting of smolts upstream of the project, sound projectors were deployed at the headrace in an angled configuration to prevent fish from entering the power canal. Two trap nets were set downstream of the projectors to monitor movement of fish into the canal. The sound system was activated for the first or last half of each night on an alternating basis over a 2-month period. Although few fish were caught in each net, the number of smolts caught was significantly lower ( $p=0.0042$ ) when the sound system was activated. Overall, 94% fewer steelhead and 81% fewer Chinook smolts were caught when the sound system was on. The highest diversion rate achieved was 100% for steelhead and 83% for Chinook in these trials.

### **Georgiana Slough**

A sound deterrent system was deployed at the mouth of the Georgiana Slough to evaluate its ability to prevent outmigrating Chinook salmon (*Oncorhynchus tshawytscha*) from entering either waterway, both of which divert water from the Sacramento River for irrigation purposes (Hanson Environmental, Inc., 1993; SLDMWA and Hanson 1996; Hanson et al. 1997). The deployment of the sound system at the Georgiana Slough consisted of a 243.8 m (800 ft) long linear array of acoustic transducers suspended from buoys that were located beginning about 304.8 m (1,000 ft) upstream of the slough entrance. The acoustic signals used to repel migrating Chinook salmon were customized to the fish and site conditions using the concepts developed from the research conducted at the Racine, Berrien Springs and Buchanan Hydroelectric Projects Sacramento River (see case study descriptions for Loeffelman et al. 1991a, 1991b; Klinect et al. 1992).

Biological evaluations of the effectiveness of the acoustic barrier were designed to determine changes in ratio of juvenile fall-run Chinook salmon capture within Georgiana Slough and the Sacramento River during both test (barrier on) and control (barrier off) periods, expressed as catch-per-unit-effort (CPUE). Sampling was performed 10 to 24 hours per day. The CPUE was based on the number of salmon captured per minute and the number of salmon per 1,000 m<sup>3</sup> (35,315 ft<sup>3</sup>) of water sampled. The study was conducted in four phases from spring of 1993 through spring 1996.

The objectives for Phase I, which was conducted in the spring of 1993, were to test the feasibility of installing and operating the underwater acoustical guidance system, measure the sound parameters to optimize array frequencies, and generate CPUE ratios to develop an index of guidance efficiency (Hanson Environmental, Inc., 1993; Hanson et al. 1997). The acoustical barrier array was composed of 10 to 12 Argotec Model 215 or 220 transducers at 300 to 400 Hz, each suspended (1.8 m [6 ft]) below the surface. The deterrent system was tested above the confluence of the Georgiana Slough and the Sacramento River. Its ability to repel Chinook salmon smolts was evaluated, and the array configuration was adjusted to achieve the maximum level of repulsion. A guidance efficiency index, calculated using the change in the relative

number of salmon entering the Georgiana Slough when the barrier was in service. The indices were lower if the barrier was effective at repulsing fish, demonstrating less fish were collected in the Georgiana Slough than the Sacramento River. The Kodiak trawls were found to be effective at generating CPUE estimates, however, floating fyke nets proved to be ineffective. Frequent Kodiak trawl catches over approximately two months with sound on and sound off showed the barrier to be increasingly effective as the angle and length was adjusted. Guidance efficiency indices ranged from -156 to +74 through the five weekly test periods. Results from tests conducted in 1993 have indicated that the signal sound system was greater than 50% effective in preventing Chinook salmon smolts from entering the slough.

Guidance efficiency evaluated in 1993 was primarily determined by comparing the catch rate of 17,000 marked fish (released 0.8 km [0.5 mi] upstream) in three fyke nets deployed behind the diversion pumps. Based on preliminary results from sound on/sound off tests conducted over four months in 1993, the consultants performing the evaluation studies reported that the signal sound system had a guidance efficiency of 83% (Cramer et al 1993). Fyke net catches of fish naturally entering the forebay and fish monitoring data close to the sound barrier with sound on and off were reported to corroborate the results from the marked fish tests.

Phase II of the sound barrier tests was conducted in the spring and fall of 1994 and involved a more rigorous evaluation of the sound system's guidance efficiency, as well as an evaluation of blockage or delay of the upstream migration of adult Chinook salmon (SLDMWA and Hanson 1996; Hanson et al. 1997). Delayed effects of acoustic exposure on fish was also investigated. The barrier was operated on a randomized 2-day-on/2-day-off schedule. Efficiency of the acoustic barrier averaged 57.2%. The guidance efficiency varied significantly with the tide, weekly test period, and on a diel basis. Fish moved freely up and downstream when the barrier was operating. Some delay in migration appeared to be associated with the sound system. However, it was suggested that more data was needed to fully support this observation. No evidence of acute or delayed mortality due to exposure to the sound system was determined.

In Phase III, which was conducted in the fall of 1995, test objectives were reduced due to flood flows and equipment problems (Hanson et al. 1997). The objectives of Phase III testing included: evaluation of the sound system on delta smelt and Sacramento splittail egg development and hatching success; evaluation of the potential of increased susceptibility of juvenile fall-run Chinook salmon, juvenile striped bass (*Morone saxatilis*), and other fish to predation due to exposure to the sound system; the evaluation of acute and delayed mortality of fish as a result of exposure to the acoustic signal; and a more thorough evaluation of potential blockages or delays in the migratory passage of fish. Twenty-one transducers were included in the sound system array for the Phase III evaluation. Tests were conducted in a randomized 3-day-on/3-day-off cycle. Delayed and acute mortality in fish did not increase with exposure to the sound system. No meaningful delay or blockage in passage due to the sound system was indicated. Studies of increased predation after exposure to the sound system were unsuccessful.

In Phase IV tests, which were conducted in the spring of 1996, guidance efficiency was evaluated under higher flows and potential delays in fish passage due to the acoustic barrier were re-evaluated (Hanson et al. 1997). Originally, 21 transducers were to be used for the Phase IV studies. However, only 18 transducers were functional after a submerged tree struck the array in late May. Studies were conducted in a 2-day-on/5-day-off cycle. Guidance efficiency for Phase IV was 15% (not significantly less than zero). Two mark-recapture studies were conducted with

salmon to evaluate 24 hour guidance efficiency and to determine if the acoustic barrier delayed downstream passage. Guidance efficiency from data on a single marked fish was -8; it was -1 for unmarked fish collected during a 24-hour period. Movements of marked salmon did not indicate there were any delays in passage due to the sound system.

### ***Wilkins Slough Pumping Station***

Sound projectors were tested as a possible means to prevent outmigrating Chinook salmon (*Oncorhynchus tshawytscha*) from entering the forebay of the Wilkins Slough Pumping Station (maximum capacity 25.5 m<sup>3</sup>/sec [900 cfs]). The acoustic guidance system, consisting of eight advanced sonar speakers, was deployed in a 76.2 m (250 ft) linear array in the river in front of the entrance to the forebay, roughly parallel to the main flow of the Sacramento River.

Guidance efficiency was evaluated primarily by comparing the catch rate of 17,000 marked fish (released 0.8 km [0.5 mi] upstream) in three fyke nets deployed behind the diversion pumps. Based on results from sound on/sound off tests conducted over 4 months in 1993, the consultants performing the evaluation studies report that the signal sound system has a guidance efficiency of 83% (Cramer et al 1993). Fyke net catches of fish naturally entering the forebay and fish monitoring data close to the sound barrier with sound on and off are reported to corroborate the results from the marked fish tests. However, these results were considered to be preliminary, as the fisheries agencies reviewing the draft report have questioned some of the assumptions used to estimate the effectiveness of the sound system. Additional testing and verification of the system's guidance efficiency was not performed.

### ***Institute of Freshwater Ecology's River Laboratories, Frome River, Dorset, UK and Blantyre Hydroelectric Station***

A Bioacoustic Fish Fence (BAFF) was tested at the Institute of Freshwater Ecology's River Laboratories on the Frome River, in Dorset, UK, and at the Blantyre Hydroelectric Station on the Clyde River, Scotland (Nedwell and Turnpenney 1997). The BAFF system uses a curtain of air bubbles to slow the speed of sound through water, in effect creating a barrier where generated sounds can be "contained" (i.e., a wall of sound). Sound is generated by transducers located at the base of the bubble plume and travels to the surface of the water where it is reflected back.

Experiments conducted at the Institute of Freshwater Ecology's River Laboratories employed the BAFF in attempt to divert outmigrating Atlantic salmon (*Salmo salar*) smolts and sea trout (*Salmo trutta*) into a mill leat that was fitted with a glass-sided fluvium and counting facility. The system was comprised of a 24 m BAFF barrier angled 12 degrees to the river flow. In 1995, 88% of the smolts were counted passing into the mill leat. Visual observations in 1996 indicated that nearly 100% of the smolts were diverted into the mill leat versus the main river channel.

Similar tests were conducted at the 575 kW Blantyre Hydroelectric Station. At this site, a 24 m (78.7 ft) BAFF array was created. The barrier was angled 18 degrees to the river bank and was intended to guide fish into a bypass adjacent to the turbine powerhouse. Hatchery-reared smolts were marked and released upstream of the project. Nets and traps were used to determine the percentage of fish passing the station via the bypass and the turbines. Results indicated that 75.2% fewer smolts passed through the turbines while the BAFF was operating.

## **Bonneville Dam**

The ability of sound stimuli to guide outmigrating juvenile salmonids away from turbine intakes was evaluated at the Bonneville Dam on the Columbia River (Ploskey et al. 1996). The Bonneville Dam hydro facility consists of two powerhouses, a spillway, and a navigation lock, as well as two islands which separate some of these structures. Sound system tests were conducted at the north end of Powerhouse I, where an array of 25 Argotec Model 215 sound transducers were installed in front of Units 9 and 10. The array was 122 m (400 ft) in length and angled from an upstream anchor point downstream to a pier separating Units 8 and 9. The depth of transducers ranged from 1.5 m to 6.0 m (4.9 ft to 19.7 ft) in the upstream half of the array and alternated between 6 m and 12 m (19.7 ft and 39.4 ft) in the downstream half. Sound signals that were evaluated comprised 300 Hz and 400 Hz crescendos that were developed from recordings of noises produced by hatchery-reared Chinook salmon (*Oncorhynchus tshawytscha*) smolts. Fish targeted for diversion included sub-yearling and yearling Chinook salmon and yearling coho salmon (*Oncorhynchus kisutch*), sockeye salmon (*Oncorhynchus nerka*), and steelhead trout (*Oncorhynchus mykiss*).

Testing of the sound deterrent system involved two series of tests conducted in June 1995. In the first series of tests, response of fish was monitored during single sound-on and -off periods that were 4 hours in duration. These tests were conducted over a 20-day period. The sequence of treatment and control periods was alternated daily. Hourly fish counts from hydroacoustic sampling were used to evaluate fish movement past the sound array. The second series of tests extended 10 days at the end of June and consisted of 24-hour treatment and control periods. The extended sample periods were intended to determine if treatment duration had an effect on the estimated effectiveness of the sound array. Mean hourly counts from treatment and control periods were compared to assess the ability of the sound system to repel juvenile salmonids during the 24-hour periods.

No significant difference was detected between fish counts collected during the 4-hour sound-on and sound-off periods. Fish counts collected during the 24-hour tests, which were separated into daytime and nighttime counts due to diel differences in passage rates, also demonstrated no significant differences between sound-on and sound-off periods. Several experimental and biological factors were examined for effects on the lack of response exhibited by smolts to the sound stimuli. These included: (1) lack of statistical power to detect differences; (2) other fish species that do not respond to sound were counted and biased the results; (3) smolts could not avoid the sound array due high water velocities (about 1.1 m/sec [3.6 ft/sec] ); and (4) smolts did not respond to the sound field. Based on an assessment of each of these considerations, it was concluded that the data analysis was statistically adequate, bias in counts by inclusion of non-smolts was unlikely, and flow velocities probably would not prevent an avoidance response from the target species and size classes. Consequently, the ineffectiveness of the sound array was attributed to a lack of innate behavioral response combined with an inability of salmonids to adequately detect the signals that were evaluated.

## **Fort Halifax Hydroelectric Project**

Two sound systems were evaluated as part of the downstream fish passage facilities at the Fort Halifax Hydroelectric Project (Environmental Consulting Services and Lakeside Engineering 1994). Strobe lights also were examined during this study, and we discussed results from their

evaluation previously. A description of the project and associated bypass facilities was provided in the description of strobe light tests. The downstream passage facilities are designed for use by Atlantic salmon (*Salmo salar*), American shad (*Alosa sapidissima*), and alewife (*Alosa pseudoharengus*). Mark-recapture techniques were used to evaluate the ability the two sound devices to repel or guide juvenile alewife away from the turbine intakes and toward the bypass entrance. The first sound device that was evaluated was an underwater alert system which emitted 4 kHz sounds at an amplitude of 110 dB. During several tests conducted under daylight conditions, no discernible response from alewife was observed based on estimated bypass efficiencies. The second sound device tested was a standard fishfinder/depthsounder hydroacoustic system, which operated at 192 kHz. This device produced a startle reaction in alewife and repelled them to a radius of about 1.8 to 2.4 m (6 to 8 ft) around the source.

### **York Haven Hydroelectric Project**

Limited testing of two sound projection systems was performed at the York Haven Hydroelectric Project in 1993 (SWETS 1994). The project is located on the Susquehanna River, 24.1 km (15 mi) south of Harrisburg, Pennsylvania. It consists of a 2,438 m (8,000 ft) dam and powerhouse containing six Kaplan turbines and 14 Francis turbines each with a capacity of approximately 22.7 m<sup>3</sup>/sec (800 cfs). The sound devices were tested as potential means for repelling juvenile American shad (*Alosa sapidissima*) away from turbine intakes and guiding them into a trash sluiceway for downstream passage.

A FishStartle system was used to produce high-frequency sound to repel shad at York Haven. Sound spectra, both pure and pulsed tones, from various fish noises were projected from speakers located on a raft in the forebay. Two narrow-beam and one wide-beam transducers were mounted on the raft. An additional wide-beam and two additional narrow-beam transducers were mounted on light floats or against the powerhouse. The position of the sound raft in front of the trash rack could be manipulated for different configurations. Distances, locations, type, and number of transducers were varied for the sound system tests. Large congregations of fish present at the time of testing allowed fish response to be assessed visually as well as hydroacoustically. A scanning sonar system (WESMAR Model SS390) was used to monitor fish response to the various test configurations. Tailrace nets were used to quantify the passage of fish through turbines adjacent to the sluiceway and through the sluiceway. Sampling was conducted at dusk on each sample day. Test conditions and control conditions lasted 1 hr. Twelve hydroacoustic samples were collected during the 1-hr treatment period. A total of 17 high-frequency sound tests were conducted over 11 days of sampling using nine different sound configurations.

Results from the sound tests revealed that aggregations of milling fish exhibited a startle response and avoidance to several of the sounds that were projected. However, the avoidance responses were not strong and did not displace fish a great distance away from the source. Furthermore, the displacements were not sustained: Fish rapidly acclimated to the condition and were observed moving back into the area.

### **Vernon Hydroelectric Project**

A FishStartle sound system was evaluated as a means to repel juvenile American shad (*Alosa sapidissima*) away from turbine intakes at the Vernon Hydroelectric Project (RMC and Sonalysts

1993). The project is located on the Connecticut River in the towns of Hinsdale, NH, and Vernon, VT. The facility consists of a concrete gravity-type dam, six tainter gates, and a log/ice boom. The ice/log boom diverts trash and ice into a sluice at the eastern end of the powerhouse. Flow varies from 1.2 to 78.4 m<sup>3</sup>/sec (43 to 2,770 cfs). The plant is a run-of-the-river type and has ten Francis turbines with a total generating capacity of 27 MW.

Two series of tests were conducted with the FishStartle system. The response of juvenile shad to sound with frequencies between 100 and 150 kHz was observed in a floating cage (set in the station forebay) to determine the optimal sound characteristics for repelling shad. A 1.5 by 2.1 by 3.0 m (5 by 7 by 10 ft) cage was constructed from PVC and plastic mesh, supported by a raft. Transducers were mounted on a metal frame attached to the raft approximately 3 m (10 ft) from the cage. Approximately 50 juvenile shad were introduced into the cage for testing. Video cameras and visual observations were used to determine the responses of fish during cage testing. Based on the results of the cage tests, a sound system was developed for testing in open water at Vernon.

The original study plan called for outmigrating shad to be repelled from entering the powerhouse forebay and guided to a sluiceway for downstream passage. Initial tests were inconclusive because the skimmer gate that regulates flow through the sluiceway malfunctioned and remained stationary at a level that was not conducive to downstream fish passage. Consequently, additional testing of the FishStartle system was conducted in the station forebay where the sound system was evaluated for its ability to repel juvenile shad from the turbine intakes and into a fish bypass pipe.

During field tests, several combinations of transducer types (i.e., wide beam and narrow beam) and locations were evaluated. At first, one wide beam and one narrow beam transducer were placed at each end of the station intake structure. The next array that was tested included additional transducers along the intake structure. The final scenario that was evaluated had transducers mounted on the log boom in addition to the locations mentioned previously. Besides the different deployment arrays, several operating modes were also tested (i.e., alternating sound emissions from opposing wide-beam transducers or modifying signal levels with narrow beam transducers). An underwater video system and scanning sonar were used to monitor fish movements during the testing of each sound system configuration. Fish movements in the forebay and fish exiting the bypass pipe were observed during test (sound on) and control (sound off) periods.

During field tests at Vernon, the FishStartle system appeared to effectively move shad back and forth along the station intake structure. As water temperatures decreased, visual observations indicated that increasing numbers of shad used the bypass pipe during sound on periods. However, few shad were observed using the bypass pipe during sound off periods. A total of 15 tests were conducted between October 5 and 26. Although the results of this study were limited to visual and scanning sonar observations in the forebay and visual observations at the bypass pipe exit, they supported the conclusion that the FishStartle system has potential for diverting juvenile American shad at hydropower stations.

### ***Hadley Falls Hydroelectric Project***

A high-frequency acoustic field was evaluated as a fish barrier in the Holyoke canal system (Hadley Falls Hydroelectric Project) located on the Connecticut River (Kynard and O'Leary

1990, 1993). Outmigrating American shad (*Alosa sapidissima*) enter the canal system through a gatehouse directly upstream of the Hadley Falls powerhouse. A fish bypass is located downstream of the gatehouse at Boatlock Station.

The sound system was deployed in a side canal located between Boatlock Station and the gatehouse. The acoustic field was produced by a sonic transducer (Wesmar SS-165 scanning sonar) with a transmission of 161.9 kHz. The sound system was evaluated by monitoring the movement of adult shad that had been radio-tagged and released into the canal. Spent American shad were captured and transported 27 m (88.6 ft) below the gatehouse, where they were tagged with radio transmitters and released. Fish were located about every hour by stationary receivers. As fish approached the bypass they were monitored more closely. The number of American shad that passed through the facility was estimated by visual counts or by an electronic counter.

Radio-tagged fish appeared to be initially repelled by the acoustic field, but would eventually pass through it. Visual observations revealed a similar behavior pattern exhibited by adult shad schools in the area of the acoustic field. Also, it was observed that the acoustic field was effective in concentrating fish in the canal, often restricting movement of shad schools. Based on the observed movements of adult shad schools and radio-tagged fish, the authors concluded that high-frequency acoustic fields may be useful for preventing turbine entrainment or concentrating fish at fishway entrances.

### ***Lennox Generating Station***

Controlled field studies using the fishdrone and hammer were conducted at Lennox Generating Station on the north shore of Lake Ontario, in eastern Ontario, Canada (2,100 MW). Tests were conducted in the forebay while the station was not in operation. The forebay was separated from the lake by 1.0 cm (0.4 in.) mesh netting. Fish species, including alewife, yellow perch, pumpkinseed, black crappie, rock bass, rainbow trout, and golden shiner, were collected nearby and transported to the forebay for testing. Hydroacoustics were used to determine fish distribution in front of each device at distances of 5, 9, 13, 17, 21, and 28 m (16.4, 29.5, 42.7, 55.8, 69, and 91.9 ft). Fish responses to the fishdrone were recorded at four frequencies: 27, 64, 99, and 153 Hz. The fishdrone was operated using a pulsed signal of 3 sec on, 1 sec off. The hammer was evaluated while operating at a frequency of 28 Hz and using a firing rate of 15–20 pops per minute.

Results of testing with the fishdrone in the Lennox forebay indicated very little directional movement of fish away from the device at frequencies of 27, 64, and 99 Hz. At 153 Hz, however, fish movement away from the walls was more noticeable and occurred in all replicates. Responses were not instantaneous; fish did not begin to move until the device was operating for a few minutes. The hammer elicited a negative response from alewife. No marked response was observed from the other fish species.

### ***Seton Hydroelectric Station***

The evaluation of a hammer device in a riverine environment was conducted in the forebay of the Seton Hydroelectric Station, Lillooet, British Columbia, Canada. The Seton facility is comprised of two major dams and four powerhouses for a total generating capacity of 470 MW. The principal species evaluated for their responses to the hammer stimulus were sockeye and pink salmon. Fish were sampled using a modified fyke net with a floating collection box at the



cod end. The nets were positioned below the surface on opposite ends of the forebay. The hammer was deployed in front of the fyke net on the south side of the forebay. It was operated 20 times per minute at a frequency of 52 Hz. Paired control and experimental tests were replicated and had a duration of 0.5 hours. Experimental tests were conducted during the peak daily migration period (between 1800 and 0400 hours). Sockeye salmon (*Oncorhynchus nerka*) smolt catches in the Seton forebay were significantly reduced by the hammer device, which averaged 75.5% effectiveness (McKinley & Patrick 1988a).

### **Allegheny Reservoir**

Studies were conducted at the Allegheny Reservoir to evaluate the effectiveness of a low frequency sound system in reducing fish losses through the bottom sluices of the dam (Smith and Anderson 1984). The Allegheny Reservoir is located on the western border of Pennsylvania and New York. The project is managed for flood control, pumped storage power generation, downstream water quality control, downstream water augmentation, and recreation. During generation the turbines can discharge up to 113.3 m<sup>3</sup>/sec (4,000 cfs) each.

The sound system employed a G34 transducer to generate sound in frequencies from 200 to 3,000 Hz. Preliminary tests at the dam site and at the Tionesta State Fish Hatchery used a J11 transducer that operated at 20 to 12,000 Hz. The J11 transducer was deployed beginning on April 23, 1980, 18.3 m (60 ft) below the water surface in the Allegheny Reservoir. Pure tone with a frequency of 500 Hz was used. In August of 1980, laboratory tests were conducted to determine the reaction of walleyes to pure tones. Tests were conducted in a 9.1 m (30 ft) long concrete raceway divided into two 4.6 m (15 ft) long sections. The transducer was submerged at the outflow end of the raceway. Frequency levels of 100, 200, 300, 400, 500, 600, 700, 800, 900, and 1,000 Hz were used. Fish behavior was recorded at each test interval by a video camera.

Ambient background noises at the reservoir were recorded and analyzed. The J11 and the use of pure tones were abandoned because they failed to elicit the desired avoidance responses from test fish under laboratory conditions. A modified sound delivery system was tested in December 1981, using the G34 transducer and recorded sound effects. The G34 was positioned 4.6 m (15 ft) above the top of sluice number 5. The output was evenly dispersed above the bottom of the six bottom sluices. An automatic timer was set to deliver sounds to the transducer for 5-minute intervals on the hour during the first 11 weeks of testing. In the 12th week of testing, the 5-minute operational sequences were randomized. Underwater sound broadcasts were found to be ineffective in reducing fish mortality at Allegheny Reservoir. The pure tones used in laboratory tests and the playback of recorded sound in the reservoir did not elicit the avoidance responses need to effectively deter fish from entering the intake structure. The authors suggest that a low frequency (500 to 600 Hz) background noise generated by water passing through the sluice may have been attracting fish toward the dam.

### **Arthur Kill Generating Station**

High- and low-frequency sound were evaluated during cage tests as part of a study that assessed the ability of a sound system to reduce impingement of bay anchovy (*Anchoa mitchilli*) and several herring and shad species at the Arthur Kill Station (Consolidated Edison Company 1994). The cage tests were conducted with young-of-the-year bay anchovy (less than 60 mm [2.4 in.]

TL) and alewife (*Alosa pseudoharengus*). High frequency signals that were evaluated ranged from 18 to 198 kHz, and low frequency signals ranged from 75 to 500 Hz. Bay anchovy were collected from the Hudson River using beach seines and a mid-water trawl and alewife were obtained from a local bait dealer. The test cage (2.4 by 1.0 by 1.2 m [8 by 3 by 4 ft]) had an aluminum frame that supported a vinyl pool cover and was suspended from a floating work platform. The transducers (directional high-frequency and omni-directional low-frequency units) were located as close to the cage as possible to maximize sound levels. Both transducers were oriented toward open water to reduce reflection of signals. A video system was used to record fish response to each signal that was evaluated.

During 66 tests conducted under daylight and nighttime conditions, the high-frequency signals did not elicit any discernible responses from bay anchovy. Alewife also were evaluated with bay anchovy during 38 of these tests and demonstrated consistent avoidance responses to signals with frequencies greater 120 kHz. In 10 tests conducted during daylight hours and three under nighttime conditions, the initial pulses of low-frequency signals produced startle responses from bay anchovy, but these reactions diminished with time and were not directional (i.e., no avoidance demonstrated by movement away from the sound source). Alewife were not evaluated for response to low-frequency signals.

### **Cage Tests – NYPA and ESEERCO**

Cage tests were conducted in a flooded rock quarry to determine avoidance responses of alewife (*Alosa pseudoharengus*), striped bass (*Morone saxatilis*), white perch (*Morone americana*), Atlantic tomcod (*Microgadus tomcod*), golden shiner (*Notemigonus crysoleucas*), and spottail shiner (*Notropis hudsonius*) to low and high frequency sound (NYPA et al. 1991). The study goal was to develop an acoustic system to deter fish from entering the cooling water intake structures (CWISs) of power plants. The quarry is located near the east shore of the Hudson River near Verplanck, New York. It has a surface area of approximately 14 hectares (34.6 acres) and a maximum depth of over 60 m (197 ft). Testing took place where the depth was 6 to 18 m (19.7 to 59.1 ft).

The fish used in testing were all young-of-the-year and yearling stock acquired from various sources (wild and commercial). The cage was a 1.5 by 1.5 by 3.9 m (5 by 5 by 12.8 ft) perforated PVC pipe structure. Behavior was monitored by two underwater cameras mounted 2.1 m (6.9 ft) from the side of the experimental fish enclosure. A hydroacoustics HLF-6 transducer was used to generate the sound stimulus in the experiments. The transducer was capable of producing sounds at sound pressure levels over 200 dB //  $\mu\text{Pa}$  at 1 m (3.3 ft) below 200 Hz. An HX-29 transducer was also used to produce sounds up to 160 dB //  $\mu\text{Pa}$  at 1 m (3.3 ft) between 100 and 1,000 Hz.

Fish were exposed to low and high frequency sounds under both day and night conditions. Sounds above 100 kHz were defined as high frequency, and low frequency sounds were those below 1,000 Hz. Immediate responses of fish were determined by reaction tests. Exclusion tests were also conducted to determine if fish could be kept out of an ensonified portion of the test cage for an extended period. Reaction tests involved a single pulse of sound over a wide range of frequencies. Based on the results of the reaction tests, potentially effective frequencies were then employed in the exclusion tests. Exclusion tests used a minimum of 900 pulses for interval durations of 15 minutes.

Responses of fish to high frequency sounds were determined by direct observation through underwater video cameras and evaluation of underwater video recordings. Exclusion tests with high frequency sound were conducted with alewife only (the most reactive species). Fifteen-minute exclusion tests were conducted day and night. During daytime tests, the cage was divided into four quadrants. Quadrants 3 and 4 were fully ensonified, and quadrants 1 and 2 were ensonified to a lesser degree.

Results of reaction tests indicated that alewives showed the strongest avoidance response to frequencies of 110 and 125 kHz during daylight testing. Exclusion tests indicated that alewife were effectively excluded in low light conditions using pulsed broadband sound between 117 and 133 kHz at 157 dB //  $\mu\text{Pa}$  due to some experimentation done with the playback of recorded sound. Extended exclusion results revealed that a strong avoidance response was not exhibited at these frequencies during the daytime. Nighttime ensonification effectively reduced the use of ensonified quadrants (a reduction of up to 52% compared to control). However, it did not produce exclusion.

Separate groups of white perch had variable responses to the different frequency ranges of sound. Group D white perch responded strongly to broadband sound between 100 and 500 Hz. Group D did not respond to single tones between 110 and 150 kHz. White perch from Group I responded strongly during the day to a single tone of 25 Hz and the recorded sound of a rock entering the water (163 to 183 dB //  $\mu\text{Pa}$ ).

Striped bass were also exposed to the recorded sound of a rock entering the water (164 dB) and a broadband sound between 110 and 150 kHz. They did not respond to single tones at these frequencies or to a single tone of 200 kHz. Striped bass were not exposed to nighttime trials at frequencies less than 1,000 Hz due to poor condition of test fish.

Spottail shiners did not respond to tones at frequencies of 110 and 150 kHz during daytime tests. They were not exposed to these frequencies at night. Broadband sound at frequencies between 117 and 133 kHz did not elicit a response from spottail shiners. In general, spottail shiners exhibited weak avoidance responses and few startle responses to the high frequency sound tests. Spottail shiners did, however, exhibit active avoidance to frequencies between 20 and 200 Hz at night and mild avoidance to recorded sound of thunder (191 dB //  $\mu\text{Pa}$ ).

Golden shiners did not respond to single tones between 110 and 200 kHz in daytime tests. At tones of 110 kHz weak lateral and sounding responses were observed, but no active avoidance response was observed to single tones between 120 and 150 kHz.

Atlantic tomcod elicited no response to single tones between 110 and 150 kHz or to broadband sound between 117 to 133 kHz. Six daytime and six nighttime tests were conducted with the recorded rock sound. No avoidance response occurred during the day, and only moderate active avoidance response was exhibited during nighttime tests.

### **Pickering Nuclear Generating Station**

Open lake tests were conducted at an experimental open water test facility (Pickering Diversion System) to evaluate the biological effectiveness of a hammer device (Patrick et al. 1988b). Two hammers were positioned on either end of the middle pilings at a depth of 3 m (9.9 ft). The hammer's effectiveness was evaluated by comparing the number of adult alewife (*Alosa pseudoharengus*) caught at both structures with no hammers operating and those caught during

the operation of two hammers per structure. Experiments were conducted between 2200 and 0200 hours, when fish movement was greatest. The duration of each experimental interval was two hours. Percent reduction of a particular deterrent was defined as the difference in the number of alewife caught between test and control periods. Results from the Pickering study indicated a consistent negative response from adult alewife to the hammer. Eighty-five percent of adult alewife exhibited a significant reduction in inshore movement.

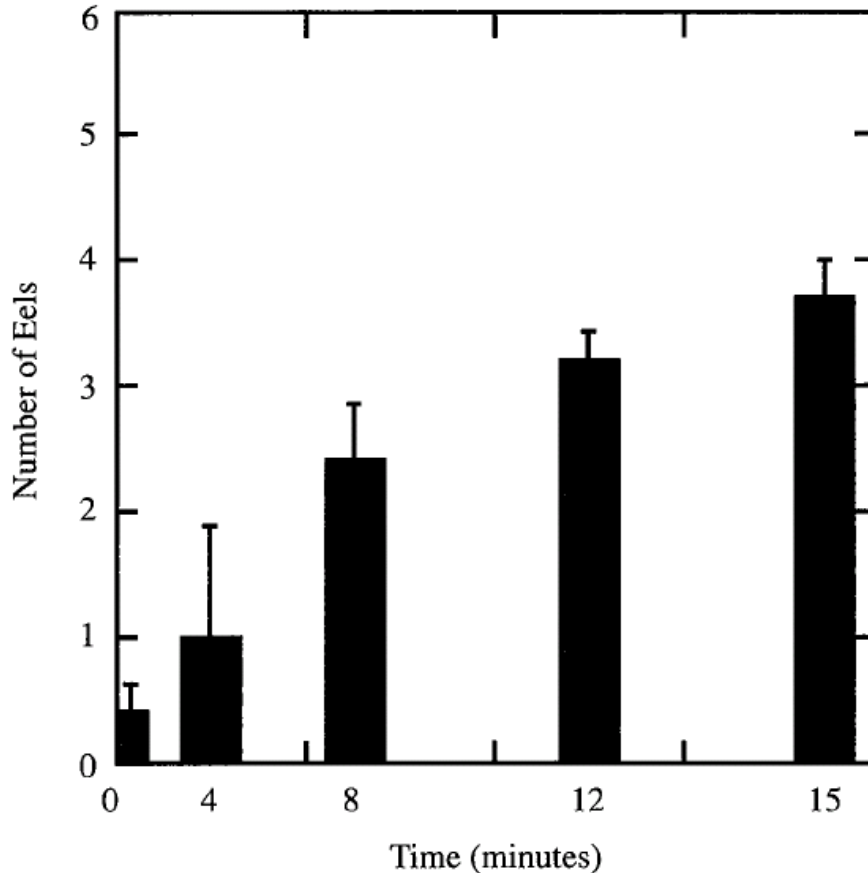
### ***Manimota Bay, Japan***

A speaker system was the subject of a large-scale study of sonic deterrents in Manimota Bay, Japan. A large net blocked the opening of the bay with the exception of a 220 m (722 ft) section for shipping. A total of six speaker assemblies were installed at the bottom, 36 m (118 ft) from the surface, on both sides of the shipping entrance. Previously taped sound stimulus of killer whales and dolphins (range of frequencies between 300 and 900 Hz) was played over the speaker system. Fish were monitored before and after the speakers operation with a laser beam. The speaker system was also used at a large power plant in Japan to prevent the movement of anchovy into the power plant intakes. It was installed at the inlet of a large bay, 100 m (328 ft) in width. The dolphin and killer whale sounds were played continuously at a sound pressure level of less than 0.5 kPa. The speaker system was estimated to be approximately 70% effective at repelling fish in Manimota Bay. According to the authors, the effectiveness of the speaker system at the power plant was difficult to assess because of low fish densities during the testing period.

### ***Laboratory Study - Kinectrics***

The effect of strobe lights and sound on the behavior of American eels (*Anguilla rostrata*) was evaluated at the Kinectrics laboratory in Ontario (formerly Ontario Hydro). American eel test fish for these studies were obtained from the R.H. Saunders Dam and the St Lawrence River. The testing facility consisted of a 5.5 m (18.0 ft) diameter tank in which sound was evaluated as both an attractant and as a conditioning agent for adult and juvenile American eels. The sound generator used was capable of creating complex resonant frequencies (< 1,000 Hz) up to 190  $\mu$ Pa at 1 m (3.3 ft) from the source. For each sound signal evaluated, five replicates and five controls were conducted. Each trial included 10 eels and lasted approximately 15 min. Conditioning trials were also conducted with walleye (*Sander vitreus*) and lake sturgeon (*Acipenser fulvescens*) fingerlings. Test fish were stocked in 1,000 L (264 gal) circular holding tanks at densities of 100 to 500 per tank and conditioned to feed upon the application of the sound stimulus. Food was delivered at 30 minute intervals during each day. Test fish were assumed to be effectively conditioned when the majority of the fish in the tanks approached the feeding mechanism when the sound stimulus was applied but before the food was delivered.

Results of the sound attraction trials reveal that both juvenile and adult eels were attracted toward the sound projector, with an average of 3.7 eels showing a clear orientation to the projector (Figure 14-2) and an additional three eels orienting toward the projector within 2 m (6.6 ft). In total, approximately 70% of the eels displayed an attraction toward the sound source. Control trials revealed a maximum of one eel within 1 m (3.3 ft) of the projector throughout the trial, with most test fish orienting away from the sound source.



**Figure 14-2**  
**Mean number of adult eels within 1 m of the experimental sound projector during attraction tests (Patrick et al. 2001)**

Results of the sound conditioning trials reveal that walleye and lake sturgeon were conditioned to feed within 10 days. Conditioned fish showed significant increases in growth (21 to 29%) and survival (3 to 50%) over controls. Additional studies of retention of the conditioned response reveal that the conditioning could last up to 3 weeks. The authors suggest that his conditioning technique could be applied at hatcheries that release reared fish as part of fisheries enhancement programs. Sound conditioning could therefore be used to increase the passage efficiencies of other technologies that may be performing poorly. The authors were careful to point out the preliminary nature of their results.

### **Case Studies – Infrasonic – CWIS Application**

#### ***Lake Borrevann, Norway; Tihange Nuclear Power Plant, River Muese, Belgium***

The avoidance response of various European fish species to intense infrasound was studied in a Norwegian lake and a Belgian power plant intake (Sonny et al. 2006). The infrasound source consisted of two symmetrical pistons in an air-filled chamber. The cylinder fronts are fitted with 25-cm (9.8-in.) diameter flexible rubber membranes that have a peak-to-peak amplitude of 5 cm (2.0 in.). In these tests, the driver motor was run at 960 rpm, resulting in a sound frequency of

16 Hz. At a distance of 4 m (13.1 ft), the particle acceleration was about 0.03 m/sec (0.1 ft.sec) (rms) (Sonny et al. 2006).

The effectiveness of the infrasound generator in repelling fish was monitored with a Simrad EY 60 echosounder (7 deg. split beam, 200 kHz). In Lake Borrevann tests, the infrasound generator was suspended 1 m (3.3 ft) below a raft in a water depth of 3 to 4 m (9.8 to 13.1 ft). Fishes showed a pronounced vertical diurnal migration at this location, with densities peaking after dusk. To study repulsion and possible habituation to the infrasound source, three different procedures were used: (1) 30-second sound repeated every 2 to 4 minutes during periods of peak fish activity; (2) sound not started until fish had redistributed after previous stimulus during period of low fish activity; and (3) sound source either running continuously or turned off for whole nights between 1600 and 0800 hours.

Strong avoidance responses were noted every time the infrasound source was activated. Fish rapidly returned to the area when the sound was turned off. Maximum reaction range was 10 m (32.8 ft). Late at night when fish were less active, similar acute avoidance was noted; however, fish did not redistribute around the sound source until after 5 to 10 min. The sustained avoidance indicates that habituation to the infrasound does not occur.

At the Tihange Power Plant, two infrasound units were placed in the center of one of twelve inlets that comprise the 72- by 5.2-m (236- by 17-ft) water intake structure. Mean water velocity ranged from 0.17 to 0.28 m/sec (0.6 to 0.9 ft/sec). The Simrad echosounder beam was aimed across the downstream side of the intake structure, with maximum coverage occurring at and around the ensonified inlet. The sound was turned on and off for 20 minute periods from 1 hour before dusk to 2 hours after sunset. Sixteen on-off test sequences were run in late January 2004. The number of fish entering the intake during sound-on periods was significantly lower than during sound-off periods; reductions of 44 to 86% were observed in the ensonified and adjacent inlets. The mean reduction across all units monitored (8 of 12 inlets for a total width of 54 m [177.2 ft]) was 47.9% ( $P < 0.001$ ).

The authors conclude from these two studies that infrasound is an effective deterrent for cyprinids and that habituation is not an issue.

### ***Annapolis Tidal Generation Station***

The effectiveness of a high-frequency sound diversion system was evaluated at the Annapolis Tidal Generation Station (Annapolis). Annapolis is located in the Annapolis River estuary in southwestern Nova Scotia, Canada. The one unit station uses a low-head propeller StraFlo turbine with an output of 17.8 MW at a 5.5 m (18 ft) head with a discharge of 408 m<sup>3</sup>/sec (14,408 cfs). Two fishways, located 12.0 m (39.4 ft) and 300 m (984.3 ft) from the forebay, were installed to facilitate fish passage.

The model 3406 transducers (4 International Transducer Corporation) were mounted across the top of the turbine intake, angled downward at 15 degrees and sideways at 30 degrees. The transducers projected band-limited, random-noise signals between 122 and 128 kHz.

Between September 7 and October 22, 1999 fish passage was monitored. Nets were deployed in the two fishways and at two locations in the tailrace before the turbine to monitor fish deterrence and diversion from the turbine intake. The barrier was tested on or off during a full generating period for 48 generating cycles.

A total of 53,000 fish representing 27 taxa were collected during the study (Table 14-3). Nine species made up 99% of the sample, Atlantic silverside (*Menidia menidia*) accounting for 90%. The results demonstrated that the sound barrier was partially effective for *Alosa* spp. At deterring fish from the tailrace, but was ineffective for all other species. Effects of environmental variables were consistent with past studies (Ross et al. 1993; Nestler et al. 1992; Popper and Carlson 1998).

**Table 14-3**  
**Number of fish collected by species at the four collection sites.**

| Species                  | Tailrace (north side) |     | Tailrace (south side) |     | New Fishway |        | Old Fishway |       | Total  | Number of Cycles |
|--------------------------|-----------------------|-----|-----------------------|-----|-------------|--------|-------------|-------|--------|------------------|
|                          | On                    | Off | On                    | Off | On          | Off    | On          | Off   |        |                  |
| Atlantic silver side     | 479                   | 304 | 464                   | 115 | 17,214      | 18,706 | 4,183       | 6,534 | 47,999 | 47               |
| Atlantic herring         | 232                   | 387 | 107                   | 165 | 317         | 561    | 50          | 38    | 1,857  | 42               |
| Northern pipefish        | 55                    | 75  | 27                    | 55  | 89          | 343    | 57          | 346   | 1,047  | 41               |
| blackspotted stickleback | 18                    | 28  | 19                    | 11  | 260         | 341    | 78          | 95    | 850    | 44               |
| blueback herring         | 70                    | 68  | 42                    | 28  | 43          | 50     | 10          | 0     | 311    | 33               |
| mummichog                | 2                     | 0   | 2                     | 2   | 22          | 75     | 12          | 54    | 169    | 14               |
| alewife                  | 8                     | 12  | 3                     | 11  | 85          | 39     | 2           | 0     | 160    | 23               |
| sea lamprey              | 10                    | 8   | 2                     | 0   | 18          | 18     | 52          | 50    | 158    | 4                |
| hake                     | 19                    | 38  | 14                    | 24  | 7           | 16     | 2           | 3     | 123    | 24               |
| All Other Species        | 49                    | 64  | 19                    | 45  | 106         | 150    | 8           | 35    | 463    | 160              |



## **Case Studies – Infrasound – Other Applications**

### ***Kingsford Hydroelectric Project***

An infrasound generator was evaluated for its ability to repel potamodromous fishes during cage tests conducted at the Kingsford Hydroelectric Project, which is located on the Menominee River between Wisconsin and the upper peninsula of Michigan (Winchell et al. 1997; EPRI 1998a, b; Michaud and Taft 2000). Several light devices and a transducer-based sound system also were evaluated during this study, and tests with each of these devices were described previously in their respective sections. Devices that produced effective stimuli during cage tests were selected for a field evaluation at the White Rapids Hydroelectric Project. A description of the study design and methods was provided in the section on strobe lights. The infrasound device consisted of a rotating valve that had openings through which water was driven by a pump. The frequency of infrasound signals (5 to 60 Hz) was determined by the speed of the rotating valve, and the amplitude was determined by the flow rate supplied by the pump. Results from tests showed little or no response by largemouth (*Micropterus salmoides*) and smallmouth bass (*Micropterus dolomieu*), yellow perch (*Perca flavescens*), walleye (*Sander vitreus*), and sunfish (*Lepomis* spp.) species to the infrasound stimulus. Rainbow trout (*Oncorhynchus mykiss*) displayed agitation but no directional avoidance. Due to the limited response observed in cage tests, the infrasound generator was not included in the subsequent field evaluation that was conducted with strobe lights and higher frequency sounds at the White Rapids Project.

### ***McNary Dam***

Infrasound and strobe lights were evaluated for their potential in redistributing migrant yearling and sub-yearling salmonids away from dewatering screens in the previously described McNary Dam Juvenile Bypass System (Johnson and Ploskey 1998). Two devices were used to generate the infrasound stimuli: a pump with a rotary valve and a reciprocating piston device. The pump was operated at 20 Hz during hourly sound on and sound off treatments (n=20). The piston device was operated at 8 Hz in summer near side dewatering screens during hourly sound on and sound off treatments (n=9).

Sound surveys were conducted in a stationary smolt transport barge and in the McNary fish separator to measure and characterize ambient infrasound. Sound fields were present in both locations. Sound pressure levels were found to be strong enough to be detected by smolts. Distributions and counts of smolts were monitored by underwater cameras. Factors including limited visibility (due to high water and turbidity during the 1997 tests) and a skewed lateral distribution of fish toward the east wall opposite side dewatering screens during both test and control treatments, provided inconclusive results from underwater camera counts. Tracking of radio-tagged smolts by the National Biological Service indicated that the behavioral devices neither increased passage time of smolts through the channel nor caused significant holding of smolts above the bypass.

### ***Roza Dam***

An infrasound generator was one of three behavioral barriers evaluated at the Roza Dam (Amaral et al. 1998, 2001). The dam is located on the Yakima River in Washington. It is approximately 208 km upstream from the confluence of the Yakima and Columbia River. The facility consists

of an irrigation canal, a concrete dam, and a screening facility that diverts outmigrating salmon into a bypass system. The bypass system returns fish to the mainstem river below the dam. Tests were conducted to determine if behavioral devices could be effective increasing the passage rate of wild Chinook salmon (*Oncorhynchus tshawytscha*) smolts into the Roza Dam screening and collection facilities.

A single particle motion generator (PMG) was used to create the infrasound stimulus for the study. The PMG is capable of producing frequencies ranging from 10 to 60 Hz (frequencies that were evaluated were between 10 to 50 Hz) and was operated at full power to maximize the area of coverage during the tests. The PMG consisted of a rotary valve, an air-filled expansion chamber, and a submersible pump.

The test facility was comprised of a floating test platform (modified pontoon boat). A 3.7 by 0.9 by 0.9 m (12 by 3 by 3 ft) aluminum frame test cage was fitted with a vinyl exterior and contained separate test channels for evaluation of behavioral responses. Fish behavior was monitored by underwater cameras positioned in the cage outside of the test channel. Responses to behavioral stimuli were assessed during treatment and control periods by introducing a group of test fish into the test channel and observing their reactions and movements. Environmental parameters were recorded throughout the test program, including ambient light, water temperature, water velocity, turbidity, and weather conditions.

Infrasound frequencies of 10, 20, 30, 40, and 50 Hz were evaluated during the PMG tests. The tests consisted of 2-minute exposure periods for each frequency. A randomized order was used for determining the emission of the five frequencies. A 13-minute period of ambient sound was used between treatments. A total of six tests were conducted during daytime and two during nighttime hours using chinook salmon. One test using pikeminnow (*Ptychocheilus oregonensis*) was conducted during the day. Real-time estimates of center of school movements were recorded by an observer during the tests to determine the response of Chinook salmon and pikeminnow to infrasound. Nighttime PMG tests employed the use of supplemental underwater lighting, as there was no other means of determining fish position during these tests.

Results of the infrasound tests indicated that no avoidance or startle response was exhibited by Chinook salmon to any of the five PMG test frequencies during day or nighttime tests. Three pikeminnow demonstrated moderate to strong avoidance to all the test frequencies except 20 Hz (no response was observed at 20 Hz). Only three pikeminnow were used for the test and no replicates were conducted, therefore, the authors suggest that the results of daytime tests with pikeminnow be viewed with caution.

### ***Rolfe Canal Hydroelectric Project***

The use of an infrasound deterrent system was evaluated as a means to increase downstream bypass efficiency at the Rolfe Canal Hydroelectric Project (Lakeside Engineering, Inc. 1996). The Rolfe Canal Project is the most upstream of three projects located on the Contocook River in New Hampshire. The project consists of a concrete spillway, a 1,220 m (4,002.6 ft) long canal, a 293 m (961.3 ft) long penstock, a powerhouse, and a 366 m (1,200.8 ft) long tailrace canal. There also is a spillway adjacent to the penstock intake structure. The penstock intake structure has two 3.7 by 12.2 m (12 by 40 ft) bar racks with 8.9 cm (3.5 in.) clear spacing. A bar rack with 1.9 cm (0.75 in.) clear spacing is located upstream of the wider-spaced racks and extends to a depth of 4.3 m (14 ft) at normal canal level. The project has a single horizontal Kaplan turbine

with a runner diameter of 3 m (9.8 ft) and a rotational speed of 150 rpm. The hydraulic capacity of the unit is 58 m<sup>3</sup>/sec (2,052 cfs) at minimum net head 9.1 m (30 ft). Anadromous species targeted for upstream and downstream passage include Atlantic salmon (*Salmo salar*) and American shad (*Alosa sapidissima*). Downstream facilities at the Rolfe Canal Project consist of narrow-spaced bar racks and a bypass with an entrance located next to the penstock intake.

In 1996, a sound deterrent system consisting of infrasound generators was installed at the entrance to the power canal of the Rolfe Canal Project. The infrasound sources developed for the canal entrance were composed of a float, a steel plate, an air-driven pneumatic oscillator (i.e., piston), and a plywood plate (the driven element). Each infrasound generator had an air filter/regulator set at 16 kg/cm<sup>2</sup> (90 psi) to provide a 57 kg (125 lb) force at 15 Hz. The canal entrance generators were attached to 12.5 cm (0.5 in.) cable anchored at the two shorelines. An evaluation of this system has not been conducted. However, cage tests were performed to assess the avoidance responses of Atlantic salmon smolts to the sound stimuli produced by the generators.

Cage tests were conducted by placing hatchery-reared Atlantic salmon smolts in a net pen and exposing them to the infrasound stimuli. Three separate series of cage tests were conducted to assess fish responses and to determine the effectiveness range of the infrasound generator. The distance at which fish were repelled from the sound source was measured to determine the effectiveness range. The net pen in which fish were observed was 0.9 m (3.0 ft) deep by 1.4 m (4.5 ft) wide by 3.7 m (12.0 ft) deep. During the first series of tests, 24 smolts were exposed to infrasound stimuli with the source located at distances ranging from 2 to 3 m (6.6 to 9.8 ft) from the upstream end of the pen. Under ambient conditions, the smolts were randomly oriented at the upstream end of the net pen (this area was shaded from sunlight). With the infrasound generator located on the centerline of the pen, fish oriented to the flow but did not move away from the source when it was activated. Similarly, fish remained in the upstream end of the cage when the source was positioned off-axis, but they moved to the side of the cage away from the generator when the infrasound was activated. To determine if smolts could be held at the far end of the cage by the infrasound, the source was activated after the test fish were forcibly crowded into the downstream end of the cage. When the sound was deactivated, 20 of the 24 fish moved back to the upstream end of the cage.

During the second series of tests, the net pen was moved toward and away from the infrasound generator to simulate movement of salmon smolts approaching the entrance of the power canal. Fourteen smolts were used during these tests, and the pen was positioned upstream of the infrasound source. All of the test fish remained about 7.6 m (25 ft) from the infrasound generator as the net pen was moved toward it from a distance of 6.7 m (22 ft) to a distance of 4.9 m (16 ft; i.e., distance from the downstream end of the pen to the source). At a distance of 2.4 m (8 ft), all but two fish were at the upstream end of the cage, which was about 20 ft from the infrasound generator. These tests were repeated after the cage was rotated 180 degrees. With the net pen positioned at distances of 6.1 and 4.9 m (20 and 16 ft) from the sound source, most fish remained at a distance of more than 6.1 m (20 ft) from the source.

In the third series of tests, the net pen was located 8 ft downstream of the infrasound source and fish position was observed before, during, and after a sound-on period. The 14 smolts that were used in the second series of tests were also used for this series. Prior to sound activation, seven fish were located at the upstream end of the net pen, and seven were located at the downstream

end. The fish in the upstream end of the pen moved downstream after the infrasound generator was activated (10 smolts were located at the downstream end of the cage). All fish moved to the upstream end of the pen when the infrasound was deactivated.

### ***Small Hydroelectric Intake, Sandvikselven, Norway***

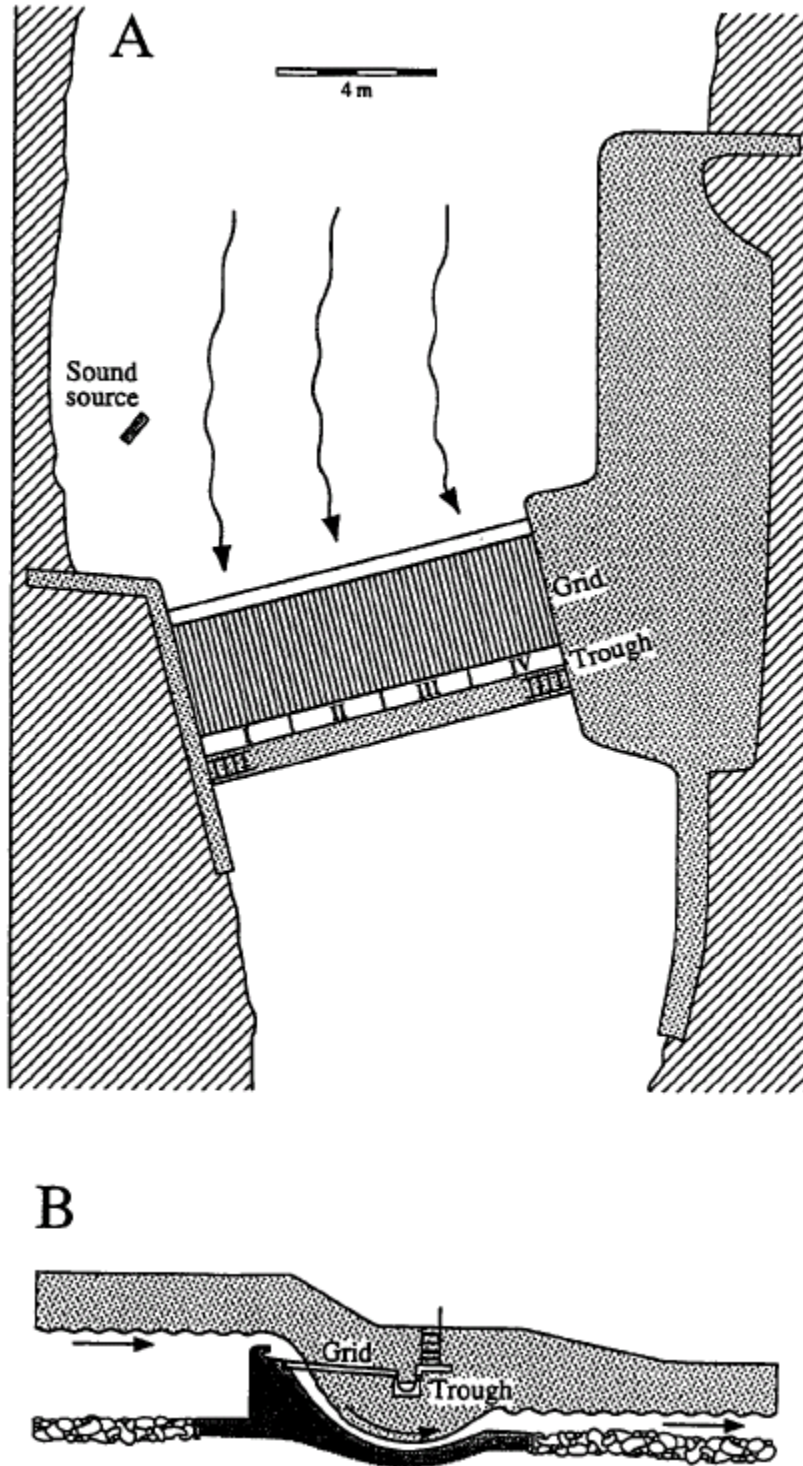
An infrasound source was evaluated for its ability to repel Atlantic salmon (*Salmo salar*) smolts from a small hydroelectric intake on a river in Norway (Knudsen et al. 1994). The device used to generate infrasound was a piston that produced a 10 Hz pulsed stimuli (this is the same device that was evaluated in laboratory experiments by Knudsen et al (1992)). Tests were conducted at an intake located on a side channel of a small river. The intake was 4 by 0.7 m (13.1 by 2.7 ft). The number of fish collected in a trap adjacent to the intake was compared between periods of sound and no sound. Observations of fish movement demonstrated that smolts turned away and moved upstream after encountering the 10 Hz stimuli. Additionally, during samples of equal time duration, 338 fish were collected in the trap during sound-off periods versus six during sound-on periods. It was concluded that infrasound generated at 10 Hz should be an effective deterrent for repelling Atlantic salmon, but that the effective range was small (about 3 m [10 ft]) and related to the near-field distance of the stimulus.

### ***Laboratory and Field Study, River Imsa, Norway***

Laboratory studies were conducted to evaluate the physiological and behavioral response of Atlantic salmon (*Salmo salar*) smolts to infrasound in the 5 to 150 Hz range (Sand et al. 2000, 2001). It was concluded that the lowest frequencies (5 to 10 Hz) elicited the strongest responses. Additional laboratory testing was then conducted in a pool with an infrasound generator constructed of a 19-cm (7.5-in.) diameter piston driven by an electric motor. The generator was placed 20 cm (7.9 in.) deep in the pool. During the pool trials, juvenile salmon (Atlantic salmon and Pacific species) displayed the strongest avoidance responses to 10 Hz signals while displaying no avoidance response to 150 Hz signals. These laboratory evaluations revealed habituation of the test fish to the stimulus, but the authors noted that in the field, habituation becomes less likely with migratory species.

The results of laboratory testing led to the design of a fully submersible infrasound generator that increased its usefulness. The new design had a cylinder diameter of 21 cm (8.27 in.) and a piston amplitude of 5 cm (1.97 in.). The eccentrically coupled motor runs at 705 rpm and produces a frequency of 11.8 Hz. Testing of this new submersible infrasound generator was conducted on silver European eels (*Anguilla anguilla*) in the laboratory to establish the proof of concept.

Once strong responses were elicited in the lab to intense infrasound, the generator was evaluated in the field in the River Imsa. The river discharge during the testing was 7 to 14 m<sup>3</sup>/sec (247 to 494 cfs) and the flow velocity was 0.9 to 1.3 m<sup>3</sup>/sec (32 to 46 cfs). An inclined trap screen with 10 mm (0.4 in.) spacings was constructed to filter all of the river flow. This screen incorporated a fish collection trough that was divided into four equal quadrants (Figure 14-3). The infrasound generator was positioned pointing downstream at an angle of 45 degrees to the trap screen at a depth of 0.7 to 1.0 m (2.3 to 3.3 ft), 3 m (9.9 ft) from the right bank, and 4.5 m (14.8 ft) upstream of the trap screen.



**Figure 14-3**  
 Sketch of the River Imsa at the site of the fish trap. (A) Horizontal view showing the position of the infrasound source relative to the trap. The collecting trough of trap was separated into four equal sections (I–IV). (B) Longitudinal section of the trap, which catches all of the descending fish (Sand et al. 2000).

Sampling was conducted during the peak of the silver eel run. A total of 370 eels was collected during periods of no stimulus (infrasound generator off). Of these, 28% were captured in section I, which was closest to the generator, and 18% in section IV, which was furthest from the generator. A total of 296 eels was collected during application of the stimulus (infrasound generator on). Of these, only 12% were captured in section I (a 57% reduction from the control numbers) and 26% were captured in section IV (a 44% increase from the control numbers). The authors indicated that the shifts in distribution during the application of the infrasound stimulus were highly significant and, therefore, represented a distinct avoidance response to the stimulus.

### **Hiram M. Chittenden Locks**

The ability of infrasound to repel juvenile salmonids was evaluated during cage tests at the Hiram M. Chittenden Locks located in Seattle, Washington (Ploskey et al. 1998b). The purpose of the infrasound evaluation was to evaluate promising behavioral devices that could potentially guide juvenile salmonids toward existing fish bypass structures and collection systems at Columbia River dams by driving them upward toward entrances. Strobe lights were also evaluated during this study. Infrasound devices that were evaluated included a particle motion generator (PMG) developed by Alden Research Laboratory, Inc., and a piston device supplied by Argotec, Inc. The PMG consists of a pump that drives water through a rotary valve with three 5 cm (2 in.) by 10 cm (4 in.) openings. The valve speed determines the frequency of water particle acceleration, and the amplitude is controlled by the flow rate supplied by the pump. The PMG was located within 30 cm (11.8 in.) of the bottom of the test pen, which was vertically oriented. Water particle accelerations were measured with a tri-axial accelerometer. The piston infrasound device had 20.3-cm (8-in.) diameter pistons, each with a 6.4 cm (2.5 in.) stroke at a speed of 500 rpm. The piston device positioned at the distance from the net pen as the PMG. The piston device was evaluated with the net pen in both vertical and horizontal positions.

Groups of 10 to 25 juvenile salmonids were placed in the net pen approximately 30 to 60 minutes before a test was initiated. Four video cameras mounted on the perimeter of the pen were used to monitor fish behavior and position. To assess fish response, center of school positions during treatment and control periods were calculated for specified time intervals. The resulting temporal and spatial patterns in the center of school position were used to determine the ability of each device to elicit avoidance reactions. Tests with juvenile salmonids produced no distinguishable behavioral reactions to PMG signals between 10 and 30 Hz. Possible explanations for the lack of responses to PMG stimuli included background noise and poor sinusoidality in the fundamental waveform. Piston tests with the pen positioned horizontally produced mild avoidance from the sub-yearling Chinook (*Oncorhynchus tshawytscha*) and coho salmon (*Oncorhynchus kisutch*). Fish within 1.2 m (3.9 ft) of the piston often turned and moved away from the source. Similarly, fish moving toward the device changed direction as they approached within about 1.2 m (3.9 ft) of the source. Piston tests conducted with the pen in a vertical orientation produced some upward avoidance when fish were within 1 m (3.3 ft) of the net bottom. However, there were not considerable differences in swimming behavior during treatment and control periods.

### **Sommaroyhamn, Norway**

A low-frequency sound barrier was tested for its ability to repel cod. Experiments were performed in a net pen at Sommaroyhamn, Norway, in 1988 (Holand and Walso 1988). The

tests were conducted in a 50,000 m<sup>2</sup> (1,765,500 ft<sup>2</sup>) tidal pool with a narrow, shallow inlet. The bottom is relatively flat and has a minimum depth of 0.5 to 1.0 m (1.6 to 3.3 ft) and a maximum depth of 7 m (23 ft) at low tide.

The sound barrier generated low frequency sound (about 30 Hz) with large particle speed. It was comprised of four pairs of transducers mounted on a float deployed across the middle of a net pen. One transducer of each pair was placed at a depth of about 1.5 m (5 ft) and the other at a depth of about 4.5 m (15 ft). The transducers created a quadruplex field with high particle speed movement. Particle speed movement slowed a short distance from the transducer plane, creating a barrier field that decreased with distance.

Two tests (Test I and Test II) were conducted during the study. For each test, attempts by fish to pass through, and actual passage through, the barrier were recorded for observation periods with the sound barrier activated and deactivated. Fish behavior was monitored by two systems: an acoustical positioning system and an underwater video camera. During the two tests, cod demonstrated an avoidance response to the sound barrier immediately after it was activated. In the first test, no cod were recorded passing through the sound barrier while it was activated. Fish were reported to turn away from the barrier when they reached a distance from the transducers where the sound was audible. Of 12 passage attempts during no sound periods, six passages across barrier location were recorded. The second test was conducted over an expanded time period. Fish responses to the sound barrier during the first 24 hours of the second test were similar to responses observed during the first test. However, during the second test, cod avoidance decreased with exposure time. The reduced avoidance response was attributed to either fish becoming conditioned to the sound or demagnetization of the transducers.

### **Laboratory Study – Pacific Northwest National Laboratory (PNNL)**

The response of juvenile salmonids to an infrasound source was evaluated during laboratory tests conducted at the Pacific Northwest National Laboratory (PNNL) (Mueller and Neitzel 1998; Mueller et al. 1999). The infrasound device tested by PNNL was described as a volume displacement source (VDS), and was similar to the piston device developed at the University of Oslo that has demonstrated an ability to repel Atlantic salmon (*Salmo salar*) smolts and juvenile Pacific salmon (Knudsen et al. 1992, 1994, 1997). The VDS consists of two pistons, each with a diameter of 10 cm (4 in.) and a peak to peak displacement of 4.5 cm (1.8 in.) (Mueller and Neitzel 1998). The pistons are located at opposite ends of the device and are driven within a frequency range of 10 to 14 Hz. The major component of an infrasound signal produced by the VDS, as well as by other infrasound generators, which is believed to elicit responses from fish, is particle acceleration.

Rainbow trout (*Oncorhynchus mykiss*), brook trout (*Salvelinus fontinalis*), and wild and hatchery fall Chinook salmon (*Oncorhynchus tshawytscha*) were evaluated for avoidance responses to infrasound during the PNNL study. The average size of each group of fish tested was less than 50 mm (2 in.), with the exception of larger brook trout that averaged between 80 and 100 mm (3.2 and 4.0 in.). Testing was conducted in a large tank with test fish contained in a net pen (1.5 by 1 by 2 m [4.9 by 3.3 by 6.6 ft]) and the VDS located 0.8 m (2.6 ft) from one end of the pen. Gridlines were included along the walls, floor, and ceiling to facilitate recording the fish responses. Testing was run in three cycles each day: morning (0700 to 0900 hours), late morning through early afternoon (1100 to 1300 hours), and late afternoon (1400 to 1600 hours). Test

groups of 20 fish were exposed to ten 3-minute sound-on events during a 1-hour period. Fish behavior during 10 3-minute control periods also was monitored. The sound-on and control periods during each 1-hour test were randomly selected. Fish behavior was monitored and recorded on videotape using three underwater cameras. The strength of responses was determined from the distances that fish moved during sound exposure periods. Responses were classified as follows: (1) none, no movement; (2) slight, 0.15 to 0.3 m (0.5 to 1.0 ft); (3) moderate, 0.3 to 0.8 m (1.0 to 2.6 ft); and (4) strong, 0.8 m (2.6 ft) or greater. Responses also were classified based on type of reaction (startle, avoidance, and habituation).

Results from laboratory tests indicated that responses of fish to infrasound stimulus were variable and depended upon species and age. Wild Chinook were more likely to respond to the VDS than hatchery-reared fish. Test fish would habituate to the infrasound stimulus after repeated exposure. Wild Chinook fry avoidance responses dropped off nearly 50% after the fourth exposure. Hatchery Chinook salmon had a high initial response, but avoidance decreased to near 20% after the fourth exposure. A startle response was observed in 16% of the first five test exposures of rainbow trout to infrasound, however, no significant avoidance behavior was exhibited by rainbow trout fry. Eastern brook trout showed the least response to infrasound. Movement of brook trout was classified as slight or none for all test groups. No startle or expansion behavior was observed.

### **Laboratory Study, Oregon State University**

A laboratory evaluation was conducted to evaluate the use of a 10-Hz frequency piston device on juvenile Chinook salmon (*Oncorhynchus tshawytscha*) and rainbow trout (*Oncorhynchus mykiss*) (Knudsen et al. 1997). Fish used in these experiments were raised and maintained at the Fish Genetics and Performance Laboratory of Oregon State University, where the experiments also were conducted. The fish were introduced into a circular tank with a diameter of 3 m (9.8 ft) and a depth of 1.1 m (3.5 ft). Water temperature was maintained at 10°C (50° F). The low frequency sound source consisted of a 1 m (3.3 ft) long, 25-cm (9.8-in.) diameter aluminum tube with a piston in the front. The piston was driven by eccentric coupling to an electric motor.

The experiments were conducted by turning on the sound source for 5 seconds and observing the reaction (an underwater video camera also recorded this behavior) of the fish in the tank. The sound source was positioned at 40 cm (15.7 in.) below the surface and behind a curtain (to avoid visual detection of the piston's movement). Two test series were conducted with eight groups. Both species of fish reacted similarly to the sound stimuli. Chinook salmon and rainbow trout in all eight groups exhibited a strong flight response during the first sound stimulation. Flight response gradually changed to avoidance over the first five sound stimulations. Avoidance did not seem to decrease, even after 20 trials. The second series of tests was conducted 1 hour after the final trial of the first series. Flight responses were evoked during the first trials followed by a change to avoidance responses in successive trials. Habituation was reached after 12 trials.

### **Laboratory Study, Norway**

The response of Atlantic salmon (*Salmo salar*) smolts to infrasound was evaluated during laboratory and field tests conducted in Norway (Knudsen et al. 1992, 1994). Fish response to 150 Hz sounds also was evaluated during the laboratory study, which is discussed in a previous section. Laboratory tests with infrasound involved evaluation of awareness retains elicited from



fish placed in an acoustic tube, and an evaluation avoidance reactions by fish placed in a concrete pool. During both the laboratory and field tests infrasound was generated using a piston device that operated at 10 Hz. The piston consisted of a 1.2 m (3.9 ft) long aluminum tube with a 19 cm (7.5 in.) diameter piston that had a peak-to-peak movement of 4 cm (1.6 in.).

During the acoustic tube tests, frequencies of 5 to 10 Hz elicited the strongest awareness reactions from test fish based on observations related to hearing thresholds, changes in heart rate, and the degree of habituation. Signals of 150 Hz also elicited responses but to a lesser degree. Based on these results, a 10 Hz signal produced by the piston device and 150 Hz signal generated by a standard transducer were evaluated with hatchery-reared and wild Atlantic salmon during tests conducted in the concrete pool. During all tests with the piston device, the 10 Hz signal produced spontaneous avoidance response for fish within 2 m (6.6 ft) of the source. Avoidance was observed even after 20 tests with the same fish during a 3- to 4-hour period. Sound signals emitted at 150 Hz did not elicit any behavioral responses from test fish during the pool tests.



# 15

## AIR BUBBLE CURTAINS

### Introduction

Air bubble curtains are created simply by pumping air through a diffuser of specific design to create a continuous, dense curtain of bubbles. The principle behind the air curtain is to elicit an avoidance response in fish. This stimulus can be visual, tactile, or both depending on lighting conditions and how close to the curtain the fish approaches. It is also possible that the noise generated by the air curtain contributes to its capability for repelling the fish.

The most extensive investigations of air bubble curtains have been conducted at steam electric stations to block the passage of fish into CWISs but could potentially be used to prevent the passage of fish into turbines. For example, an air curtain was not effective in reducing impingement of white perch (*Morone americana*), striped bass (*Morone saxatilis*), and clupeids (Family Clupeidae) at the Indian Point Generating Station on the Hudson River (Vanderwalker 1967). After several years of operation, the air curtain was removed. In addition, air bubble curtains have been evaluated for their ability to divert fish at hydropower turbine inlets. The success of these devices at all water intakes has been variable but generally poor and appears to be affected by such factors as species, temperature, light intensity, water velocity, and orientation within the waterbody.

Similarly, at the Commonwealth Edison Company Quad-Cities Generating Station, located on the Mississippi River, an air bubble curtain was not found to be effective in reducing fish impingement [primarily gizzard shad (*Dorosoma cepedianum*)] when placed across the entrance to the intake canal (Latvaitis 1976). At the Prairie Island Nuclear Generating Plant on the Mississippi River, small decreases in impingement were achieved for crappie (*Pomoxis* spp.) and freshwater drum (*Aplodinotus grunniens*) when an air curtain was placed across the intake canal. However, the number of individuals of other species [carp (*Cyprinus carpio*), silver chub (*Hybopsis storeriana*) and white bass (*Morone chrysops*)] entering the canal actually increased (Grotbeck 1975). The air curtain was therefore removed.

At the Monroe Power Plant, an air bubble curtain was installed across the mouth of the intake canal in 1972. The curtain created a continuous stream of air bubbles from bottom to surface. On the basis of daily fish counts made with the system either on or off during 7-day periods, it was concluded that an air bubble curtain was not effective in preventing yellow perch (*Perca flavescens*), walleye (*Sander vitreus*), gizzard shad, freshwater drum, alewife (*Alosa pseudoharengus*), or smelt (*Osmerus* spp.) from entering the intake canal (Detroit Edison 1975).

Although not a power plant application, air bubble curtains have been used successfully in diverting Atlantic herring (*Clupea harengus*) to fish traps and in directing them to shallow areas where they can be more easily seined by commercial fishermen. Experimental applications in the United States and Canada from 1958–1960 led to the installation of permanent air curtain systems by fishermen (Smith 1961) with effective results.

The use of an air bubble curtain to exclude alewife from the Milwaukee River was investigated (Kupfer and Gordon 1966). An air bubble curtain was installed in the Milwaukee River just

north of its confluence with the Menomonee River. Data obtained from gill net samples and observations of dead alewife above and below the curtain indicated that the air curtain was somewhat successful in stopping the alewife from migrating up the Milwaukee River (Kupfer and Gordon 1966). However, the effectiveness of the barrier could not be quantified.

Stewart (1982) was successful in confining roundfish in sea cages with the use of an air bubble curtain. Studies in Canada have also shown that the effectiveness of the air bubble curtain in excluding fish passage can be relatively high (70–98%) under artificial, low-level light conditions (Patrick 1982b).

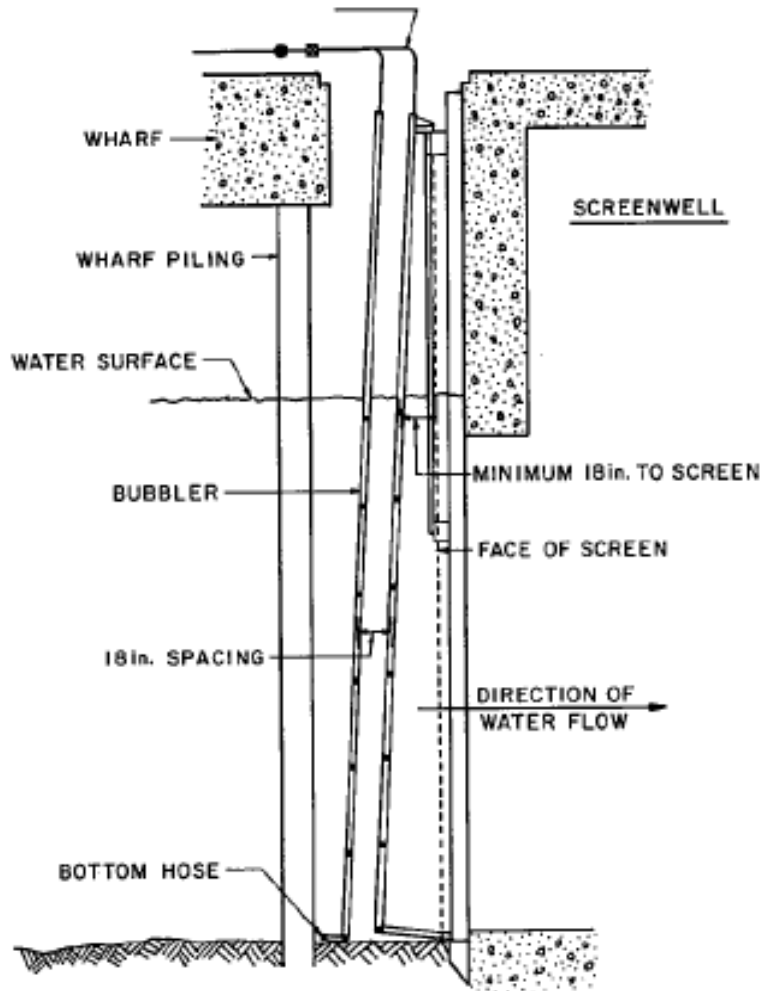
When used in conjunction with strobe lights, the device appears to have potential for reducing fish passage under various conditions of turbidity. For example, when evaluated, the combination of an air bubble curtain with sound was shown to hold potential for diverting salmon smolts (Welton et al. 2002; see Case Study below).

The effectiveness of air bubble curtains may be highly species-specific, however, some species have actually been attracted to the device. Variables which appear to influence performance of the device include water velocity, turbidity, and illumination (illumination appears to be a key factor influencing effectiveness).

## **Case Studies – CWIS Field Tests**

### ***Indian Point Generating Station***

An experimental air bubble array was tested in front of an intake forebay at the Indian Point nuclear generating station, which is located on the Hudson River in New York. Fixed, fine-mesh screens had previously been installed that successfully reduced the impingement of larger fish. However, large numbers of smaller fish such as young-of-the-year white perch (*Morone americana*), Atlantic tomcod (*Microgadus tomcod*), and herrings (*Alosa* spp.) were still collected on the fine-mesh screens. In an attempt to repel fish from the intakes, the air bubble array was installed in 1972. The array was comprised of two vertical rows of horizontal bubblers, with the bubblers spaced 1.2 m (4 ft) apart in each row as shown in Figure 15-1. The outer row of bubblers was placed 91.4 cm (36 inches) in front of the screen, while the inner row was 45.7 cm (18 inches) in front of the screen. Air bubbles were discharged from the bubblers through holes that were 0.8 mm (1/32 in.) in diameter and spaced 12.7 mm (1/2 in.) apart (Alevras 1974).



**Figure 15-1**  
**Cross section of air bubbler array in front of intake bay 12 at Indian Point Unit 1. Side extensions of bubblers not shown (Alevras 1974).**

Initial tests were conducted in February 1972 in which 25.5 m<sup>3</sup>/min (900 ft<sup>3</sup>/min) of air were released from the bubbler array. However, this volume of air distorted the flow pattern in front of the screens causing hydraulic problems in the intake. A model test was conducted that indicated an optimal flow rate of 11.3 m<sup>3</sup>/min (400 ft<sup>3</sup>/min) which was implemented in subsequent testing. Tests were conducted at bay 12, which is one of four intake bays (bays 11 through 14) at Unit 1 of Indian Point Station. The bubbler was operated over a 10-day period and the number of fish collected from the screens in bay 12 was compared to the other three bays in which a bubbler was not installed. During the periods before and after the bubbler was operated, 30% of all fish collected on the screens at Unit 1 were collected from bay 12. During the period in which the bubbler was operated, the percentage of fish collected from bay 12 decreased to 5.7% (Table 15-1) (Alevras 1974). However, over the same period the percentage of fish collected from bays 13 and 14 increased while the percentage of fish collected from bay 11 decreased. This suggested that the presence of the bubbler caused a significant change in the distribution of fish collected at Unit 1.

**Table 15-1**

**Total number of fish, average number per day and percent of total collected from the four intake bays at Indian Point Unit 1 for three time intervals.**

| Time interval                               | Bay 11 | Bay 12 | Bay 13 | Bay 14 | Total  |
|---------------------------------------------|--------|--------|--------|--------|--------|
| 2-5 Feb 72 (No air bubbler):                |        |        |        |        |        |
| Total Number                                | 2,044  | 1,908  | 1,013  | 1,385  | 6,350  |
| Average / Day                               | 511    | 477    | 253    | 346    | 1,588  |
| Percent of Total                            | 32.2   | 30.0   | 15.9   | 21.8   |        |
| 17-29 Feb 72* (air bubbler on Bay 12 only): |        |        |        |        |        |
| Total Number                                | 3,779  | 1,440  | 8,403  | 11,679 | 25,301 |
| Average / Day                               | 378    | 144    | 840    | 1,170  | 2,530  |
| Percent of Total                            | 14.9   | 5.7    | 33.2   | 46.2   |        |
| 6-15 Mar 72 (No air bubbler):               |        |        |        |        |        |
| Total Number                                | 2,005  | 2,736  | 2,147  | 532    | 7,420  |
| Average / Day                               | 201    | 274    | 215    | 53     | 742    |
| Percent of Total                            | 27.1   | 36.9   | 29.0   | 7.1    |        |

\*excluding days 21-23 Feb 72

During the test period, the average number of fish collected per day at Unit 1 was greater than the average number collected per day before and after the test period. However, while it appeared that this increase was attributable to the presence of the air bubbler affecting fish behavior in front of the screens, it was also possible that it was due to an increase in the density of fish near the intake during testing.

Additional testing took place with the air bubbler system installed at bay 12 during the summer of 1972. However, during these tests the fixed screens at bays 11 and 12 were removed and those at bays 13 and 14 were raised once daily for cleaning. This complicated the evaluation of the bubbler system. Nonetheless, this testing tentatively showed that the air bubbler at bay 12 did not repel fish when the fixed screen was absent. Testing also showed that the number of fish collected with the air bubbler operating significantly increased during nighttime, whereas the number of fish collected during daylight hours was the same with the air bubbler operating as without. The air bubbler did not appear to repel fish and may have actually attracted fish during nighttime.

Testing in February and the summer of 1972 did not conclusively demonstrate the effectiveness of the air bubbler system. Thus, by December 1972, a temporary air bubbler system had been installed across all four intake bays at Unit 1. The bubbler system was operated continuously during the month. Although this precluded a comparison between the numbers of fish collected during periods of bubbler operation and not in operation, the daily counts of fish collected over this period were less than expected based on previous fish collections during this time of year.

In June 1973, after Unit 1 was taken out of service, Unit 2 began operation with a complete air bubbler system in place that incorporated the design of the original test system. Impingement rates were low throughout the summer. During the early fall when impingement rates typically increased dramatically, the number of fish collected remained at an all-time low for that time of year. However, because comparisons of fish counts with and without the air bubbler system in operation were not made, it was not possible to determine if the reduced impingement rates were due to the air bubbler system or natural causes.

### ***Roseton Generating Station***

Field tests with strobe lights, poppers, and an air bubble curtain were conducted at the Roseton Generating Station. The results demonstrated that certain combinations of the three barriers were more effective at repelling fish than any of the devices tested alone (Matousek et al. 1988). At Roseton, however, no single device or combination of devices was an effective behavioral barrier for all fish species under all conditions. Strobe lights performed best when combined with either of the other two devices, although the popper and the air bubble curtain were ineffective when tested alone and together. In addition, the estimated effectiveness index for a barrier system comprising all three devices indicated that fish were attracted, not repelled, by the hybrid system. The results of the Roseton study may be considered inconclusive because considerable variation existed between study years and among species. The variability in effectiveness estimates may have been related to annual variations in species abundance and environmental conditions or species-specific behavioral responses to the devices that were tested.

### ***Pickering Nuclear Generating Station***

Tests conducted at an offshore facility at the Pickering Nuclear Generating Station examined the same devices that were evaluated at Roseton, and depending on the device or combination of devices tested, produced either similar and contrasting results (Patrick et al. 1988a,b; Ontario Hydro and LMS 1989; EPRI 1989). Poppers were the most effective device tested at Pickering with effectiveness indices that exceeded 70% when they were tested alone and in combination with either strobe lights or the air bubble curtain. The results from the studies that were conducted at Roseton and Pickering were probably strongly influenced by local environmental conditions (i.e., Pickering is located on Lake Ontario and Roseton on the Hudson River) and the fish species that were exposed to the test devices. Subsequent differences between the Roseton and Pickering results underscore the general conclusion that the effectiveness of behavioral fish protection technologies can be highly site- and species-specific. However, different research methodologies (e.g., fish capture techniques and equipment) can introduce varying levels of sampling error and, consequently, results may differ as well. Also, the Pickering study, like the Roseton study, experienced high variability in effectiveness estimates between study years and among species.

## **Case Studies – Hydroelectric Field Tests**

### ***White Rapids Hydroelectric Project***

An air bubble curtain was evaluated as means to repel potamodromous fish species during field studies at the White Rapids Hydroelectric Project (EPRI 1998b). Strobe lights and a sound system also were evaluated during this study, and the effectiveness of these devices was

discussed previously. A description of the study design and methods and project design were provided in the section on strobe lights. The air bubble curtain was evaluated alone and in combination with each of the other two devices. During two weeks of sampling, the number of fish entrained through Unit 1 was not significantly reduced when the air bubble curtain was operated either alone or with one of the other devices. Based on these results, it was concluded that air bubble curtains may not be appropriate for sites with potamodromous fish assemblages similar to that of White Rapids.

### **Four Mile Hydroelectric Project**

During a study conducted at the Four Mile Hydroelectric Project in Michigan, an air bubble curtain was evaluated as a fish deterrent along with strobe lights (discussed previously; GLEC 1994; McCauley et al. 1996). Entrainment of bullhead (*Ameiurus* spp.) and shiner (Family Cyprinidae) species was reduced from control levels by 43% and 81% when the air bubble curtain was operated alone and in combination with strobe lights, respectively (McCauley et al. 1996). The results of this study indicate that air bubble curtains should be considered as a potentially effective fish protection technology when used in combination with strobe lights.

### **Seton Hydroelectric Station**

Tests conducted at the Seton Hydroelectric Station examined strobe lights, a popper, a hammer, and an air bubble curtain for their ability to repel outmigrating sockeye salmon (*Oncorhynchus nerka*) smolts (McKinley and Patrick 1988). Each device was evaluated alone, and strobe lights were also paired with the popper and with the air bubble curtain. Individually, the popper demonstrated greater effectiveness for repelling sockeye smolts than the strobe lights did. When combined, the hybrid strobe light/popper system was more effective than the strobe lights alone, but the hybrid effectiveness was only about 2% greater than the estimated effectiveness of the popper alone. The combined strobe light/air bubble curtain barrier demonstrated low effectiveness (about 11%), however, it was more effective than the air bubble curtain alone. The Seton test results support the conclusion that air bubble curtains are not a viable behavioral barrier and also indicate that air bubble curtains may not be appropriate as a hybrid system component if salmonids are the targeted species. It was suggested that the greater effectiveness of the sound devices compared to the strobe light resulted from larger areas of influence exerted by the hammer and popper. High water velocities were identified as a factor that may prevent the effective deployment of a hybrid behavioral system because fish reaction distances are reduced in higher water flows rendering one or more of the devices ineffective. At Seton, high water velocities may explain why effectiveness was not considerably greater for the strobe light/popper combination than for the popper alone, i.e., fish had time to react to the popper but not to the strobe light.

### **Heysham 1 and 2 Power Stations**

Turnpenny (1993) evaluated the effectiveness of an air bubble curtain diverting fish away from Cooling Water Intake Structures (CWIS) at Heysham 1 and 2 Power Stations on Port Heysham, Liverpool, England. An air bubble curtain was installed in front of the Heysham 1 and 2 Power Stations to divert organisms from their CWIS. The bubble curtain was 80 m (262.5 ft) long with 1-mm (0.04-in.) drilled air outlet holes. A testing program was conducted to evaluate the effectiveness of the air bubble curtain.



Testing was conducted from February 4-27, 1993. Sampling was carried out every other day where the air-bubble curtain was turned on or off on alternating days. Collections of impinged fish and shrimp were made at 6-hr increments using 6-mm mesh bags placed into the screen backwash gulleys. After collection, organisms were sorted by species and species of interest were enumerated and weighed. Daily totals were taken for other species.

Totals of 53,589 fish, weighing 352 kg (776 lbs) and representing 42 species and 16,000 shrimps weighing 15 kg (33 lbs) were collected in the 24-day study. Clupeids dominated the collection, comprising 87% of the total collection.

Overall reduction of impingement for all species when the air bubbler was in operation was 30% (Table 15-2). Clupeids showed the greatest reduction in impingement while gadoids (cods and hakes) demonstrated a slight increase in impingement. Data supports that the air bubble curtain more effectively excludes fish at night. The results demonstrated that the air bubble curtain is effective enough in its current configuration at the power station and any further improvements would involve an addition of other behavioral stimuli.

**Table 15-2**  
**Heysham 2 bubble curtain percent impingement reduction**

| Species    | Percent Impingement Reduction |
|------------|-------------------------------|
| Flatfish   | 6.0%                          |
| Clupeids   | 31.0%                         |
| Gadoids    | -1.0%                         |
| Others     | 41.0%                         |
| Total Fish | 30.0%                         |
| Shrimps    | 28.0%                         |

## Case Studies – Laboratory Studies

### *River Frome, UK*

The efficacy of sound coupled with bubble screens was tested for its ability to divert Atlantic salmon (*Salmo salar*) smolts on the Frome River in Britain (Welton et al. 2002). Testing facilities were installed on a millstream that leaves 25 m (82.0 ft) upstream of a gauging weir, returns 2 km (1.2 mi) downstream, and carries one-third of the total drainage flow of the River Frome. Experiments were conducted in two glass-sided channels built in a tank house.

Welton et al. used a Bio-Acoustic Fish Fence (BAFF) commercially available through Fish Guidance Systems (FGS) Ltd, c/o Marine and Freshwater Biology Unit, Fawley, Southampton, UK. This system generated sound pneumatically at a pressure level of 170 dB at 1  $\mu$  Pa and a frequency of 200 Hz, which was selected based on earlier research by Hawkins and Johnstone (1978) that determined that this was the optimal sensitivity of Atlantic salmon hearing. Measured pressure levels decayed to a level of 20 dB at 5 m (16.4 ft) from the bubble sheet. The bubble curtain used approximately 1 L/s per meter of barrier length.

Migrating smolts were counted using time-lapse video recording equipment operated at 6-frames per second. Red lights provided illumination at night. Video images were taken against a white

background. Mechanical screens were used to guide fish to within 30 cm (11.8 in) of the glass that allowed visualization in all but the most turbid conditions. Velocity measurements and mean discharge levels were recorded throughout testing.

Tests were conducted in both 1995 and 1996. Prior to testing, the distribution of smolts between the north and south channel was anticipated to be 1:1. As such, the facility was designed to allow screening of the north channel only, and results were to be compared with the unprotected south channel. However, smolts ran predominantly through the south channel (6:1 during the day and 1.5:1 during the night). Air bubble alone, sound only, and the BAFF were tested. Preliminary results of these tests (142, 4-hr replicates; n = 4,159 smolts) showed significant deflections of smolts at night for all screens and only the BAFF at during daytime. Based on these results, Welton et al. (2002) decided to focus their research in 1996 on the BAFF only.

In 1996, two BAFF were installed 10 m (32.8 ft) upstream of the entrance to the channels to form a downstream pointing V that lined up with the central pillar that separated the two channels. Mesh screening (5 mm [0.2 in.]) kept smolts from passing from one channel to the other after passing the BAFF. Additional screens were used to guide fish toward the video equipment. Each BAFF was 12 m (39.4 ft) long (4 units) and angled 12 degrees to the flow. Both units were independent so that one of the following operating conditions could be run: 1) North BAFF only on, 2) South BAFF only, or 3) neither BAFF operating. Testing was conducted during both night and day with a total of 235 replicates run continuously during April/May except during occasional breakdowns or adverse (flooding) conditions (Table 15-3). During testing, dawn was approximately at 0500 hrs, and dusk was at 1900 hrs. Daylight hours were considered to be between 0500 and 2100 hrs. Hours of darkness were considered to be between 2100 and 0500 hrs. Screens were cleaned between replicates. Only a few seconds were required to change between conditions. For analysis, the 4-hour replicates were divided at the mid-way point.

Efficiency estimates were calculated as the proportion of smolts moving down one channel when the BAFF is on relative to the portion of smolts going down the same channel when screens were off. We give efficiencies with 95% confidence intervals in Table 15-4.

**Table 15-3**  
**Number of replicates at each time period for each operating system (Welton et al. 2002)**

| Time         | Deflection System |               |          |       |
|--------------|-------------------|---------------|----------|-------|
|              | North BAFF on     | South BAFF on | Both off | Total |
| 0700–1100    | 13                | 14            | 14       | 41    |
| 1100–1500    | 10                | 14            | 13       | 37    |
| 1500–1900    | 10                | 13            | 12       | 35    |
| 1900–2300    | 11                | 12            | 14       | 37    |
| 2300–0300    | 14                | 15            | 15       | 44    |
| 0300–0700    | 10                | 17            | 14       | 41    |
| <b>Total</b> | 68                | 85            | 82       | 235   |

**Table 15-4**  
**Efficiencies of BAFFs with 95% CL during hours of daylight (0500–2100 hrs) and darkness**  
**(2100–0500 hrs) (Welton et al. 2002)**

| Operating Regimen | South | North | $P_{on}$ | Efficiency (%) | Lower 95% CL | Upper 95% CL | z        |
|-------------------|-------|-------|----------|----------------|--------------|--------------|----------|
| <b>Daylight</b>   |       |       |          |                |              |              |          |
| South BAFF on     | 103   | 211   | 0.3280   | 43.8           | 37.1         | 48.5         | 6.66***  |
| North BAFF on     | 232   | 115   | 0.3314   | 20.3           | 10.7         | 34.4         | 2.35*    |
| BAFFs off         | 213   | 152   |          |                |              |              |          |
| <b>Darkness</b>   |       |       |          |                |              |              |          |
| South BAFF on     | 74    | 482   | 0.1331   | 73.8           | 67.0         | 79.1         | 13.07*** |
| North BAFF on     | 447   | 69    | 0.1337   | 72.9           | 65.6         | 78.6         | 12.32*** |
| BAFFs off         | 248   | 241   |          |                |              |              |          |

$P_{on}$  = Proportion through the screened channel; z – test statistic for difference in proportions ( $P_{on}$  vs.  $P_{off}$ ).  
 \*, \*\*\* Denote statistically significant differences at  $P < 0.05$  and  $P < 0.001$ , respectively.

During testing, the mean discharge of the millstream was 1.68 m/sec (5.5 ft/sec) or ~30% of the total Frome River flow. During testing, 2,587 smolts were identified via the video system. Of these, a greater number migrated during the night than during the day (1,561 vs. 1,026). Nearly equal numbers of fish were present regardless of BAFF mode of operation (i.e., north BAFF on, south BAFF on, or both BAFFs off) or time of day and ranged from 314 to 365 in daylight and 489 to 556 in the dark. There was also a fairly uniform distribution of smolts in both the north and south channel when both BAFFs were turned off with slightly greater numbers choosing the south channel (1.4:1 in the daylight and 1.03:1 in darkness).

Estimates of effectiveness were greater for both the north and south BAFFs during darkness than during daylight hours (Table 15-5). There were significant deflections of smolts for both BAFFs during daylight and darkness. The values in Table 2 were calculated assuming that the efficiency of the BAFFs did not change during the smolt migration period and that the fish responded independently. The variations in the efficiencies of the BAFF during testing appear in Table 15-4 and Table 15-5. Only the south BAFF during daylight hours showed any statistically significant variation in smolt passage. Data were corrected for temporal variation in average efficiencies (using Mantel-Haenszel weighted averages), and the resulting values indicate no statistically significant differences in the efficiency of the two BAFFs.

**Table 15-5**  
**Estimated efficiencies of the BAFFs over the smolt season during daylight and darkness hours**  
**(Welton et al. 2002)**

| Period          | Proportion of Smolts (out of Total) Passing Through the North Channel When                                 |               |                | Efficiency of BAFF (%) |                    |
|-----------------|------------------------------------------------------------------------------------------------------------|---------------|----------------|------------------------|--------------------|
|                 | North BAFF on                                                                                              | South BAFF on | Both BAFFs off | North                  | South              |
| <b>Daylight</b> |                                                                                                            |               |                |                        |                    |
| 4-1 to 4-27     | 0.175 (80)                                                                                                 | 0.571 (84)    | 0.271 (155)    | 35.4                   | 41.2               |
| 4-28 to 5-3     | 0.184 (38)                                                                                                 | 0.821 (56)    | 0.324 (34)     | 43.1                   | 73.6               |
| 5-4 to 5-10     | 0.450 (151)                                                                                                | 0.626 (131)   | 0.529 (119)    | 14.9                   | 20.5               |
| 5-11 to 5-31    | 0.333 (78)                                                                                                 | 0.814 (43)    | 0.632 (57)     | 47.2                   | 49.5               |
|                 | Breslow-Day $\chi^2$ with 3 d.f. and test probability ( <i>P</i> ) for equality of deflection efficiencies |               |                | $\chi^2 = 4.44$        | $\chi^2 = 12.94$   |
|                 |                                                                                                            |               |                | <i>P</i> = 0.218       | <i>P</i> = 0.005   |
|                 | Weighted average deflection efficiency using Mantel-Haenszel estimation method (95% CL)                    |               |                | 29.7 (15.2 – 41.8)     | 40.5 (29.6 – 49.7) |
| <b>Darkness</b> |                                                                                                            |               |                |                        |                    |
| 4-1 to 4-27     | 0.114 (289)                                                                                                | 0.840 (418)   | 0.455 (279)    | 74.9                   | 70.6               |
| 4-28 to 5-3     | 0.108 (74)                                                                                                 | 0.971 (34)    | 0.505 (111)    | 78.6                   | 94.1               |
| 5-4 to 5-10     | 0.256 (86)                                                                                                 | 0.936 (78)    | 0.646 (65)     | 60.4                   | 81.9               |
| 5-11 to 5-31    | 0.090 (67)                                                                                                 | 0.962 (26)    | 0.471 (34)     | 81.0                   | 92.7               |
|                 | Breslow-Day $\chi^2$ with 3 d.f. and test probability ( <i>P</i> ) for equality of deflection efficiencies |               |                | $\chi^2 = 1.03$        | $\chi^2 = 5.11$    |
|                 |                                                                                                            |               |                | <i>P</i> = 0.794       | <i>P</i> = 0.164   |
|                 | Weighted average deflection efficiency using Mantel-Haenszel estimation method (95% CL)                    |               |                | 73.3 (67.0 -78.3)      | 75.5 (69.8 – 80.2) |

The estimated efficiencies were much higher at night and may be indicative of smolts using visual cues during daylight to locate gaps in the curtain. In addition, Welton et al. indicate that silting of the perforated pipe was problematic during times when the BAFF was not operational. Continuous operation may be necessary for such an installation to be effective especially in waterbodies with mobile sediments. At this site, background noise levels were low and did not interfere with projected signals. A bubble curtain may not maintain integrity in substantially higher flow velocities.

### **Laboratory Studies, Various Locations**

In laboratory studies, Patrick et al. (1985) demonstrated that a combined strobe light/air bubble curtain barrier had a higher level of effectiveness for deterring alewife (*Alosa pseudoharengus*) than an air bubble curtain used alone. Effectiveness of the combined barrier ranged from 90 to

98% depending on water velocity and turbidity level. The effectiveness of the air bubble curtain alone ranged from 38 to 73%.

Similar results were obtained in another laboratory study that examined the behavioral responses of spot, Atlantic menhaden (*Brevoortia tyrannus*), and white perch (*Morone americana*) to strobe light, an air bubble curtain, and a combined strobe light/air bubble curtain barrier under three levels of turbidity (McNinch and Hocutt 1987). In this study, the combined barrier demonstrated a greater ability to repel fish than did either barrier tested alone, except for spot (*Leiostomus xanthurus*). The ability of an air bubble curtain alone to repel fish was considerably different between these two laboratory studies. Patrick et al. (1985) found the air bubble curtain to be highly effective (>90%) for gizzard shad (*Dorosoma cepedianum*) and smelt (*Osmerus* spp.) and McNinch and Hocutt (1987) determined air bubble effectiveness to be less than 50% for white perch, menhaden, and spot (*Leiostomus xanthurus*). The differences in study results may have resulted from species-specific responses or dissimilar research methodologies and subsequent effectiveness (avoidance) calculations. It should be noted that air bubble curtain barriers generally have been discounted as a viable fish protection device because of poor fish deterrent capabilities when used alone (EPRI 1986a). However, because air bubble curtains have demonstrated an ability to improve the effectiveness of other behavioral devices, they continue to be tested.

### **Laboratory Study – Alden**

Model studies were conducted to determine the effectiveness of an air bubble curtain in reducing fish entrainment (Stone and Webster 1976). Tests were conducted in a large basin model that incorporated two identical intake segment structures. The air bubble curtain device consisted of a 0.91 m (3 ft) long, 1.3-cm (0.5-in.) inside diameter stainless steel pipe, with eighteen 0.87 mm (1/32 in.) holes drilled evenly along the pipe at 5.1-cm (2-in.) intervals. A compressor supplied air to the pipe via flexible plastic tubing.

Tests were conducted with rainbow smelt (*Osmerus mordax*) (6.3 to 10.2 cm [2.5 to 4.0 in.]) and alewife (*Alosa pseudoharengus*) (6.0 to 11.5 cm [2.4 to 4.5 in.]) at velocities of 0.15, 0.37, and 0.69 m/sec (0.5, 1.2, and 2.0 ft/sec). The air bubble curtain was effective in reducing fish entrainment relative to the control. The mean number of fish entrained per test (200 fish tested at a time), was 66 with the air bubble curtain and 151 for the control. In addition, there was no relationship between entrainment and velocity (i.e., entrainment did not increase with increasing velocity). Preliminary results did, in fact, suggest a decrease in entrainment at the higher velocities (Stone and Webster 1976).



# 16

## HYBRID BEHAVIORAL BARRIERS

Hybrid behavioral guidance and deterrent systems have been evaluated extensively during past studies (EPRI 1999). Hybrid systems generally are designed to take advantage of two or more effective devices in attempts to achieve a greater level of success than would occur with any of the selected devices used alone. Also, because the effectiveness of behavioral devices can be species- and size-specific, the use of multiple devices may afford protection to a wider range of species and age classes. Often, devices that have been evaluated as an integrated fish protection system take advantage of different behavioral responses to enhance effectiveness. Many systems have been designed with behavioral deterrents (e.g., strobe lights, sound) and attractants (underwater mercury lights, overhead lights). Deterrent devices typically are placed at a location to repel or guide fish from an intake, and attractants are deployed near safe areas or at bypasses. Behavioral technologies also may be used in combination with other types of fish protection devices (e.g., screens, narrow-spaced bar racks).

The results of hybrid behavioral system evaluations have been equivocal: in some cases efficiency is improved while in others efficiency is decreased. Generally, the gains in effectiveness when two or more devices have been combined as a fish protection system have not been substantial (EPRI 1999). Though some evaluations have illustrated the potential of hybrid barriers, a study conducted with sound, strobe lights, and an air bubble curtain demonstrated that these systems, used in combination or alone, did not reduce entrainment of potamodromous fishes at a hydroelectric project (Winchell et al. 1997; EPRI 1999). Fish protection systems that incorporate the use fish deterrent and attractant devices may be more appropriate than systems with multiple deterrents. At the Richard B. Russell Project, the use of high-frequency sound to repel blueback herring (*Alosa aestivalis*) from pump back intakes and overhead lights to attract them to low-velocity safe areas proved to be very effective.

Several case studies describing the evaluations of hybrid systems are presented in Chapters 13, 14, and 15. In many cases, while individual behavioral barriers have demonstrated limited effectiveness on their own, when evaluated as part of a hybrid system, their contribution toward the effectiveness of the collective system is unclear. Case studies highlighting recent studies on hybrid systems are presented in this chapter.

### Case Studies – Field Evaluations

#### ***Delaware Bay – PSEG/Alden Research Laboratory***

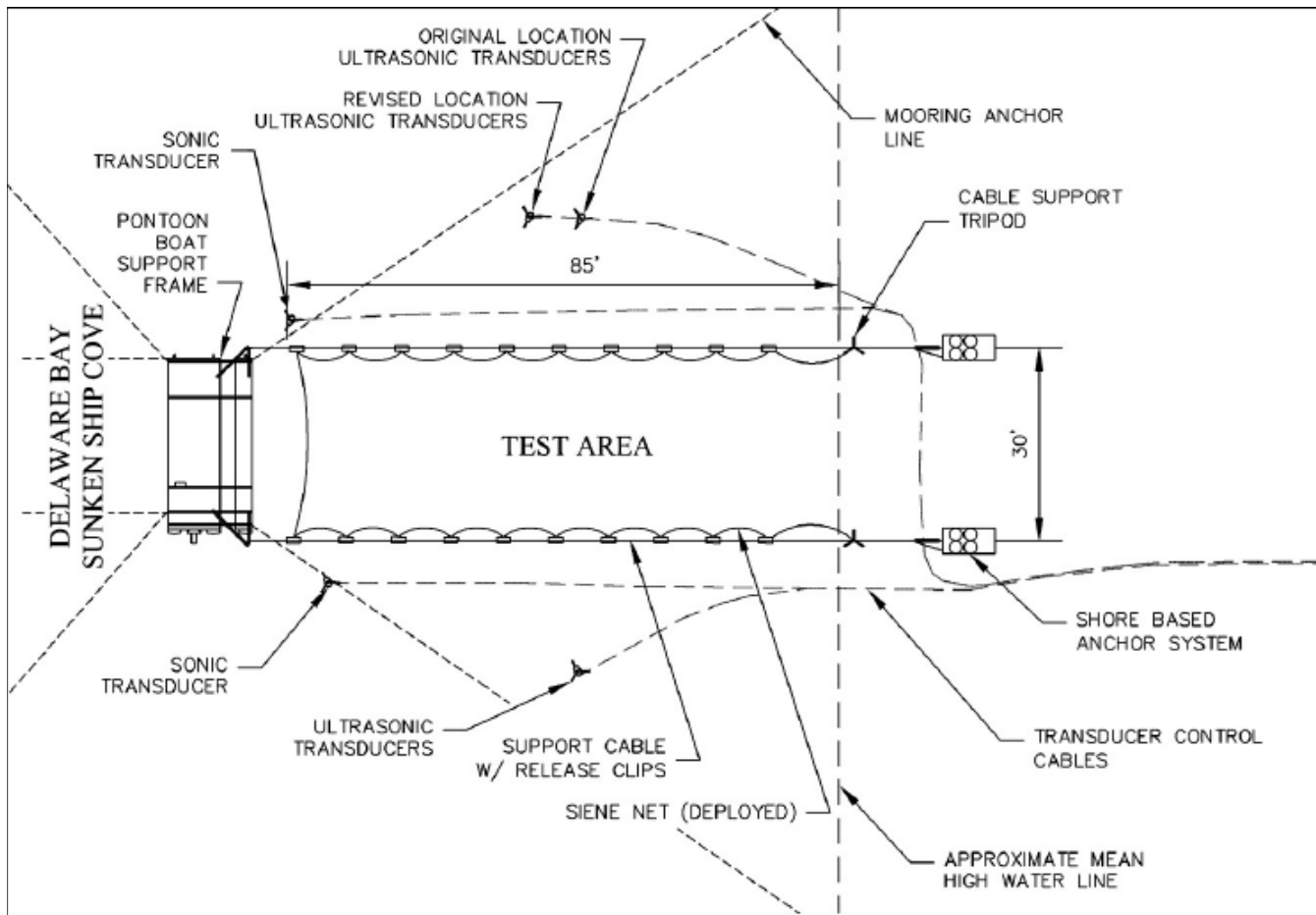
Based on results obtained during laboratory testing of hybrid systems (see case study below), an eight-month field evaluation of a proposed sound system was conducted as the second phase of a three-phase study at the Salem Nuclear Generating Plant (Salem). During Phase 1 laboratory testing at Alden Research Laboratory, it was concluded that sound had potential to elicit avoidance responses from a number of commonly impinged species at the Salem intake. Both strobe lights and air bubbles were eliminated for further consideration due to engineering constraints and lower biological effectiveness. The objective of the Phase 2 field evaluation was to determine the deterrence potential of a sound system installed at a shoreline location

approximately 1 km (0.6 mi) from the Salem intake. A discreet test area was ensounded for a period of time and differences in catch data between sound-on and sound-off treatments were compared (PSEG 2005).

The field site was a protected cove located downstream of the Salem intake on the Delaware River. Collection of fish from within the test area was accomplished with a modified seine net that was capable of being set, deployed, and retrieved from shore. The system was comprised of a pontoon boat and two on-shore tripods that supported the net. The net was deployed and retrieved via a system of pulleys and sliding clips. The rectangular sampling area measured 25.9 by 9.1 m (85 by 30 ft) (Figure 16-1) and the maximum water depth was approximately 2.7 m (9 ft) at normal high tide. The seine net measured 61.0 by 3.0 m (200 by 10 ft) and had round mesh measuring 9.5 mm (3/8 in.) in diameter.

The sound system consisted of two sonic (low frequency) and four ultrasonic (high frequency) transducers. The sonic transducers (U.S. Navy J-11 amplified by a QSC Model USA 1310 amplifier) were mounted on short tripods near the bow and stern of the pontoon boat at a high tide-depth of 2.4 m (8 ft) and 0.3 m (1 ft) off of the river bottom. The ultrasonic transducers (International Transducer Corporation Model 3406 amplified by an L6 amplifier, Instruments, Inc.) were mounted in pairs on tripods positioned 12.2 m (40 ft) from the shore and 6.1 m (20 ft) on either side of the sampling area. At high tide, the ultrasonic transducers were positioned about 0.6 m (2 ft) off of the river bottom. A schematic of the sampling area and transducer locations is provided in Figure 16-1 (PSEG 2005).





**Figure 16-1**  
**Plan view of the sampling equipment and test area (PSEG 2005)**

The low frequency sound transducer delivered a signal with the following components:

- 100-400 Hz broadband sound
- 100-400 Hz sweep
- Synthetic croak
- Authentic Atlantic croaker croak
- 500-3,000 Hz broadband noise
- 500-3,000 Hz sweep

The high frequency transducer (International Transducer Corporation Model 3406 amplified by an L6 amplifier, Instruments, Inc.) delivered a signal with the following components:

- 80 kHz
- 90 kHz
- 100 kHz
- 120 kHz

During both low and high frequency testing, each signal component was 300-ms long with a 40-ms pause between signals. The entire signal sequences were repeated continuously with a 1-sec pause between transmissions. The sound field was mapped before and after the testing was conducted. Measurements were made along 5 transects with points inside and outside the sampling area.

Sampling of fish during sound-on and sound-off treatments was conducted during daylight at high tide (one hour before and one hour after) over a period of 8 months from April-November, 2004. Sampling followed a randomized block design with one control and one treatment per block. Each block was completed in two days with one day for treatment collection and the other for control collection. Two samples were collected per day one hour on either side of high tide. Collected fish were sorted by species, enumerated, and measured for length. Post-processed fish were released downstream of the sampling site. Analysis of deviance (ANODEV) was used to statistically analyze the effects treatments as well as collection time (one hour before or after high tide).

A total of 48,910 fish was collected representing 41 species and 23 families. Bay anchovy (*Anchoa mitchilli*), Atlantic menhaden (*Brevoortia tyrannus*), Atlantic silverside (*Menidia menidia*), white perch (*Morone americana*), and blueback herring (*Alosa aestivalis*) comprised 79.2, 12.2, 5.9, 0.5, and 0.5%, respectively, of the total catch. The biggest catches occurred during October and November and the smallest in April. Most fish were less than 125 mm (4.9 in) in length.

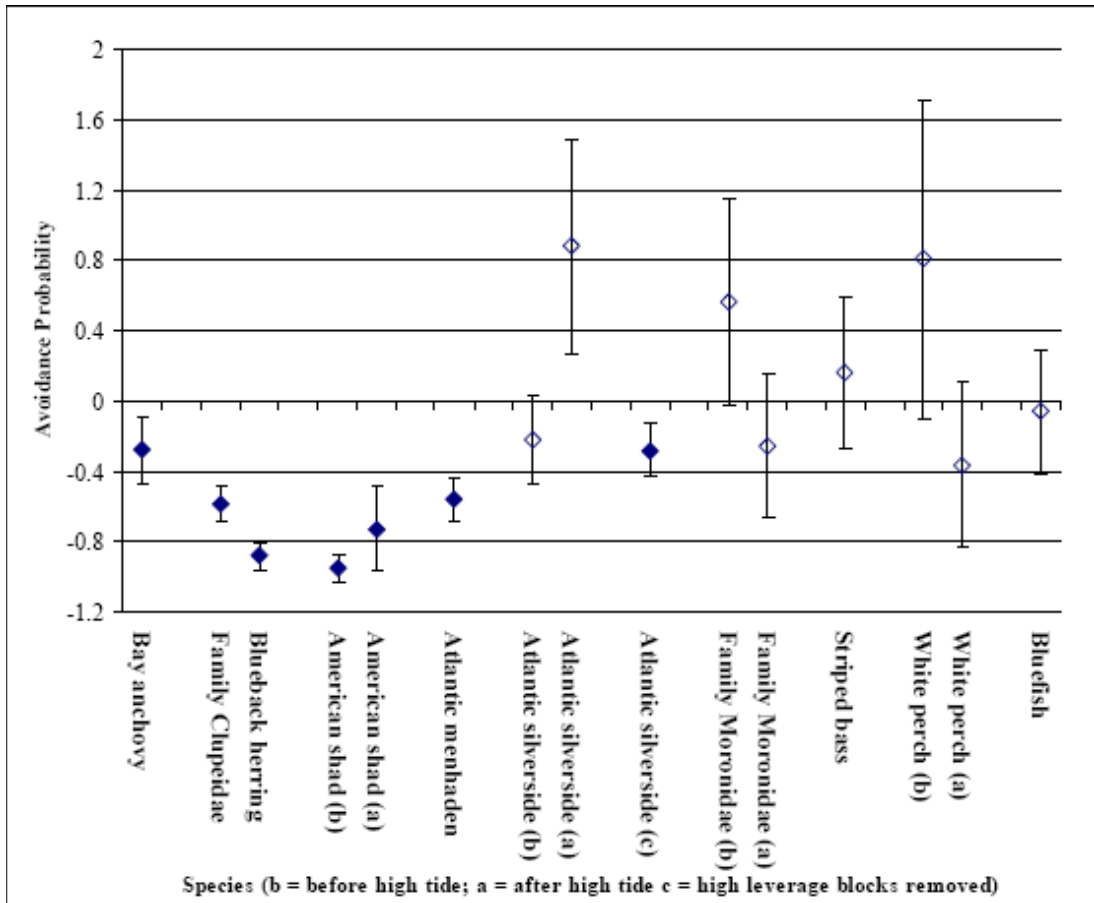
Five of the eight species for which analyses were conducted displayed significant avoidance responses to the sound system (Figure 16-2, Table 16-1). Statistical analysis revealed that significantly fewer bay anchovy were collected during the sound-on treatment (avoidance probability of -0.280); 28% fewer anchovy were collected during the sound-on treatments. Extrapolation from the numbers of fish collected during this study estimates that impingement

numbers of bay anchovy could potentially be reduced by 20-30% at the Salem intake through the use of this sound system.

Clupeids as a group (blueback herring, alewife, Atlantic herring [*Clupea harengus*], American shad, gizzard shad [*Dorosoma cepedianum*], and Atlantic menhaden) displayed a strong avoidance to the sound system. The overall avoidance probability for this family of fishes was -0.587. Specifically, blueback herring, American shad, and Atlantic menhaden displayed significant avoidance probabilities of -0.883, -0.957 (before high tide and -0.730 after), and -0.562 respectively. Therefore potential impingement reductions of 50 to 90% could be realized for clupeids.

Statistical analysis revealed a significant interaction between treatment condition and sample time for Atlantic silverside with an avoidance probability of -0.219 before high tide and an avoidance probability of 0.880 (attraction to sound) after high tide. After adjusting for the effect of two large samples that may have confounded the results, the overall adjusted avoidance probability was -0.283. Therefore, results of these field studies indicate that impingement of Atlantic silversides could be reduced by 20 to 30%.

Though there was some apparent attraction to sound, no significant difference in avoidance was seen with Moronidae species (striped bass and white perch). Similarly, bluefish (*Pomatomus saltatrix*) did not display any significant avoidance during sound-on treatments.



**Figure 16-2**  
**Avoidance probabilities (with 95% confidence intervals) by species and family. Separate probabilities are presented for each sample time if a significant interaction was detected between test condition (sound on and off) and sample time (one hour before and after high tide). Statistically significant avoidance probabilities are indicated with solid symbols. Positive values indicate attraction and negative values indicate repulsion (PSEG 2005).**

**Table 16-1**

**Summary of avoidance probabilities (95% confidence limits in parentheses) for species and families with sufficient data for conducting statistical analyses. For cases where a significant interaction between test condition and sample time was detected, avoidance probabilities were estimated separately for each sample time. Overall probability estimates represent combined sample data (i.e. no interaction effect). Statistically significant probabilities (p,0.05) are indicated by an asterisk.**

| Species/family                   | Before high tide         | After high tide         | Overall                   |
|----------------------------------|--------------------------|-------------------------|---------------------------|
| bay anchovy                      | -                        | -                       | -0.280 (-0.464, -0.095) * |
| Family <i>Clupeidae</i>          | -                        | -                       | -0.587 (-0.686, -0.489) * |
| blueback herring                 | -                        | -                       | -0.883 (-0.962, -0.804) * |
| American shad                    | -0.957 (-1.04, -0.877) * | -0.730 (-0.974, -0.485) | -                         |
| Atlantic menhaden                | -                        | -                       | -0.562 (-0.684, -0.441)   |
| Atlantic silverside <sup>1</sup> | -0.219 (-0.475, 0.036)   | 0.880 (0.273, 1.488)    | -                         |
| Atlantic silverside <sup>2</sup> | -                        | -                       | -0.283 (-0.435, -0.130)   |
| Family <i>Moronidae</i>          | 0.560 (-0.029, 1.150)    | -0.256 (-0.666, 0.153)  | -                         |
| striped bass                     | -                        | -                       | 0.160 (-0.591, 0.269)     |
| white perch                      | 0.807 (-0.101, 1.715)    | -0.364 (-0.832, 0.105)  | -                         |
| bluefish                         | -                        | -                       | -0.062 (-0.410, 0.287)    |

<sup>1</sup> Statistical analysis includes data from blocks during which large numbers of Atlantic silversides were collected during sound-on periods (i.e. possible outliers).

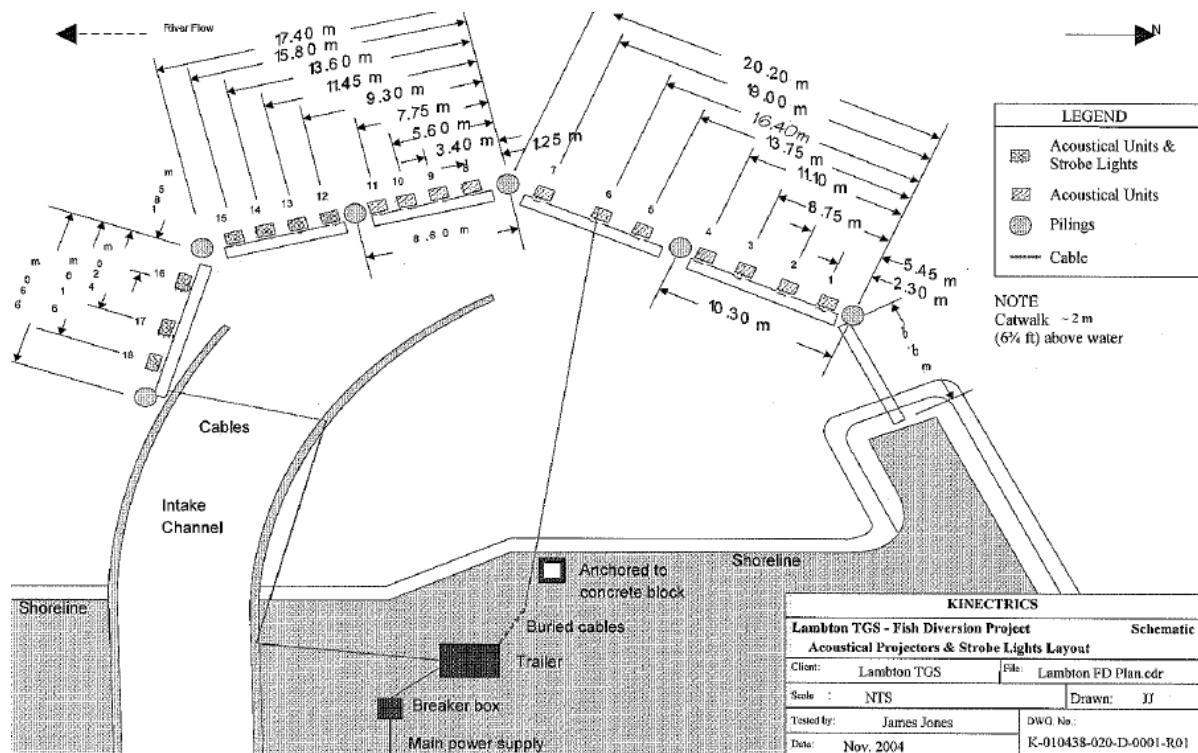
<sup>2</sup> Statistical analysis excluded data from blocks during which large numbers of Atlantic silversides were collected during sound-on periods.

It was generally concluded that a sound deterrence system designed to deliver sonic (100 to 5,000 Hz) and ultrasonic (80 to 120 kHz) signals has the potential to reduce the impingement of some of the representative important species (RIS) at the Salem intake. Specifically, sound may successfully reduce impingement of bay anchovy, clupeids, and Atlantic silversides. However, the cost of installation would need to be weighed relative to the potential benefits of impingement reductions.

### ***Lambton Generating Station***

Past operational issues occurring with gizzard shad (*Dorosoma cepedianum*) impingement prompted Lambton Generating Station to install and evaluate a hybrid barrier system at the entrance of its cooling water intake channel (Patrick et al 2005, Cord et al 2007). Lambton Station is located on the St. Clair River, 26 km (16.2 mi) south of Sarnia, Ontario, Canada. It is a two unit thermal generating station capable of producing 950 MWe. A demonstration hybrid barrier (Figure 16-3) consisting of 18 acoustic devices and nine strobe lights was evaluated for effectiveness from November 2004 through April 2005 (Patrick et al 2005). Because of its success (73% reduction relative to controls [Patrick 2005]), the system was put into full service

for the months of November through April, from November 2005 through April 2007 (Cord et al. 2007).



**Figure 16-3**  
**Layout of the strobe light-acoustic hybrid system installed at Lambton (Cord et al 2007)**

The hybrid barrier system was installed and operational by November 25, 2005. Prior to installation, high numbers of fish were being impinged. Through December 2005 and early January 2006, impingement numbers were 25 fish or less per day. However there was a spike in impingement from the middle to the end of February 2006, where impingement was up to 200 fish per day. The majority of fish collected during the high impingement event were observed to be young-of-year gizzard shad. The lack of effectiveness during this period was attributed to a 5 to 10 m (16.4 to 32.8 ft) gap in the barrier at the north end of the intake. Deterrents were not installed at the north end because the barrier was designed to deter fish that were attracted to the thermal discharge of the discharge plume (south of the CWIS) from entering the south end of the intake. This was the first incident that fish were observed approaching the intake from the north. After the event, consistent low impingement numbers were observed through April 2006.

The hybrid barrier was reinstalled and operational by November 10, 2006. It was fully operation until December 4, 2006, when units were shut down due to ice damage. Lambton has assessed various options to mitigate this issue, but there is no immediate cost justification at this time. On February 26, 2007, the system was confirmed fully operational. Lowest impingement was observed from November 2006 through February 2007, where average impingement was 0.14 fish per day and there was never more than five fish impinged in a day. The highest impingement occurred during the month of March, but the highest impingement events observed were 10 fish impinged on March 19 and March 26. No fish were observed entering the north end of the intake as in February 2006.

## ***Plant Barry Generating Station***

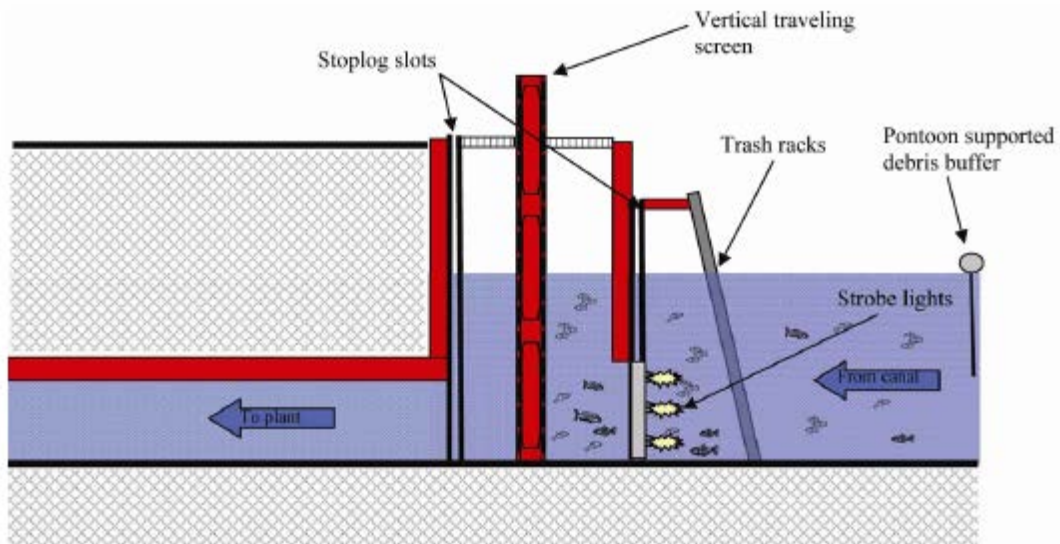
A field evaluation was conducted to examine the effectiveness of an underwater hybrid (light and sound) behavioral fish deterrent system for reducing impingement of freshwater fish at a cooling water intake structure (CWIS) located at an Alabama Power Company (APC) Plant Barry Generating Station (Mobile River, Mobile County, Alabama) (EPRI 2008; Baker 2008).

This field study evaluated the effectiveness of a hybrid (light and sound) and sonic (sound only) deterrent system at APC's Plant Barry Generating Station CWIS on the tidal freshwater section of the Mobile River from the spring to the winter of 2006. The study compared impingement rates when the deterrent systems were on (treatment) or off (control) at both CWIS 1-3 (spatial control) and CWIS 4-5 (hybrid or sonic frequency pulse deterrent equipped). Only CWIS 4-5 was equipped with the deterrent systems. The types of sound signals and strobe light flash rates were chosen based on the responses of representative fish species that exist in the literature along with the advice of other researchers.

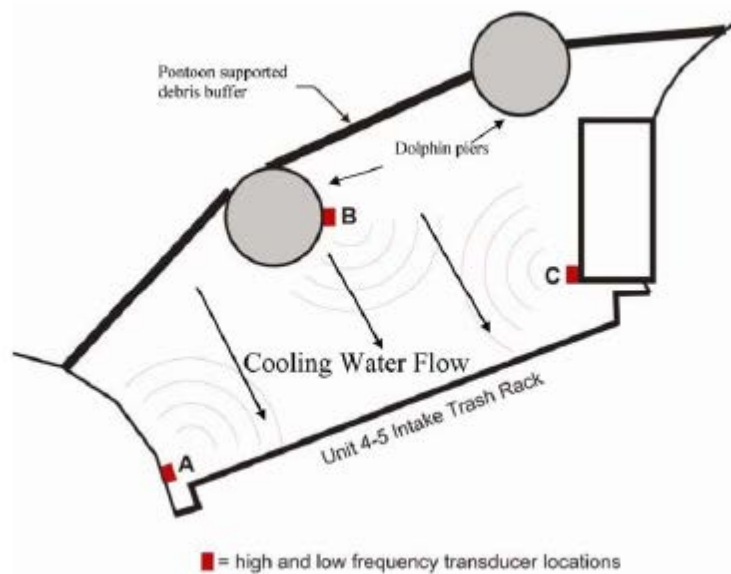
- The hybrid deterrent system combined strobe lights (300 flashes per min), sonic (0.4–4.0 kHz), and ultrasonic sound frequencies (120–130 kHz).
- The sonic or low frequency sound burst deterrent consisted of random tones at 0.40, 0.63, 1.00, 2.50, and 3.15 kHz.

Impingement sampling was used to determine the effectiveness of these deterrent systems. In addition, split-beam (200 kHz, Biosonics DTX) and multi-beam (1.8 MHz, DIDSON) hydroacoustics sonar allowed monitoring of fish abundance or density in the immediate vicinity of the deterrent system. Various environmental parameters were also monitored to ensure that these variables were not interfering with the evaluation of the deterrent systems.

Evaluation of the Hybrid Deterrent system began in May 2006 and ended November 2006 at the Units 4-5 intakes. Evaluation of the low frequency sound burst deterrent began November 2006 and ended in December 2006. The sound (Figure 16-4) and light (Figure 16-5) were projected into the forebay of the cooling water intake structure. For the sound component, deterrent sound pressure and background noise levels were measured to ensure deterrent sound pressures were sufficiently greater than background pressures to affect fish behavior.



**Figure 16-4**  
**Location of the strobe light frames within the stoplog slots of Units 4-5 CWIS**



**Figure 16-5**  
**Locations of the 3 sonic and 5 ultrasonic sound frequency transducers inside the intake forebay of the Units 4-5 CWIS. One sonic and two ultrasonic transducers are located on each side of the intake structure (A and C). Location B is equipped with only one sonic and one ultrasonic transducer.**

The strobe light portion of the hybrid deterrent system was very problematic and required intensive, unexpected maintenance on the strobe lights and on the power converters. Almost biweekly repair or replacement of flash-heads and power converters was required. On average 88% (range of 73-100%) of the lights were operational throughout this evaluation. For the hybrid deterrent, the sound pressure levels were approximately 160 dB for the sonic component



and 145 dB for the ultrasonic component. For the sonic deterrent, the sound pressure levels ranged from 147 to 168 dB. Except for the sonic component of the hybrid deterrent, the deterrent sound pressure levels were greater than 30 dB over background noise levels.

Over 12,000 fish and 9,000 non-fish organisms were collected during 268, 4-hour impingement samples while evaluating the hybrid deterrent system. Over 29,000 fish and 800 non-fish organisms were collected during 73, 4-hour impingement samples while evaluating the sonic deterrent system. Twenty-six species of fish were collected throughout both evaluations. Predominant species collected during each evaluation are presented in Table 16-2.

**Table 16-2**  
**Common name, scientific name and percent collected of the predominant fish species collected during each evaluation type**

| <b>Evaluation Type</b> | <b>Common Name</b> | <b>Scientific Name</b>       | <b>Percent Collected</b> |
|------------------------|--------------------|------------------------------|--------------------------|
| Hybrid Deterrent       | bay anchovy        | <i>Anchoa mitchilli</i>      | 57.9                     |
|                        | freshwater drum    | <i>Aplodinotus grunniens</i> | 10.6                     |
|                        | blue catfish       | <i>Ictalurus furcatus</i>    | 8.9                      |
|                        | hogchoker          | <i>Trinectes maculatus</i>   | 7.3                      |
|                        | channel catfish    | <i>Ictalurus punctatus</i>   | 4.2                      |
|                        | silverside minnow  | <i>Menidia sp.--</i>         | 3.2                      |
|                        | threadfin shad     | <i>Dorosoma petenense</i>    | 2.6                      |
|                        | skipjack herring   | <i>Alosa chrysochloris</i>   | 1.9                      |
| Sonic Deterrent        | threadfin shad     | <i>Dorosoma petenense</i>    | 54.1                     |
|                        | blue catfish       | <i>Ictalurus furcatus</i>    | 19.1                     |
|                        | freshwater drum    | <i>Aplodinotus grunniens</i> | 17.3                     |
|                        | channel catfish    | <i>Ictalurus punctatus</i>   | 4.7                      |
|                        | gizzard shad       | <i>Dorosoma cepedianum</i>   | 2.1                      |
|                        | bay anchovy        | <i>Anchoa mitchilli</i>      | 1.2                      |

A split-plot analysis was performed on impingement data for total fish, individual, fish and non-fish species with sufficient numbers. This analysis included the sequential treatment (deterrent on) and control (deterrent off) sampling events within each weekly test period. Similar analyses were performed on the hydroacoustic monitoring data set. Temporal and environmental variables were considered and accounted for through paired evaluations during individual weeks.

Significant reductions in impingement were not shown by the split-plot analysis for both the paired treatment evaluation of the total and the individual species while either deterrent system was in operation (Table 16-3). Furthermore, hydroacoustic monitoring within the CWIS during the hybrid deterrent evaluation confirmed that these behavioral stimuli had no effect on movement of fish immediately upstream from CWIS trash racks or inside screen pits. Environmental variables appeared to influence the overall impingement rates. Rates generally increased with higher dissolved oxygen, lower temperatures, and night time hours, however no analysis of impingement rates between these variables and the deterrent systems operation (on and off treatment periods) was conducted.

The results of the hybrid and sonic fish deterrent testing demonstrated that none of the behavioral stimuli evaluated (strobe lights, sonic sound, or ultrasonic sound) was capable of reducing the impingement of freshwater organisms could not be used as an effective technology option for reducing impingement at Plant Barry.

**Table 16-3**  
**Results of the MLE Split-Plot analyses of the transformed (natural log) impingement rates using the SPSS mixed procedure.**

| Type III Tests of Fixed Effects |                         |              |                |         |       |
|---------------------------------|-------------------------|--------------|----------------|---------|-------|
| Deterrents                      | Source                  | Numerator df | Denominator d1 | F       | Sig.  |
| Hybrid Deterrent Evaluation     | Intercept               | 1            | 16.009         | 201.352 | 0.000 |
|                                 | INTAKE                  | 1            | 15.875         | 3.908   | 0.066 |
|                                 | TREATMENT               | 1            | 30.733         | 1.186   | 0.285 |
|                                 | Sample                  | 3            | 186.308        | 70.882  | 0.000 |
|                                 | INTAKE*TREATMENT        | 1            | 30.733         | 0.071   | 0.791 |
|                                 | INTAKE*Sample           | 3            | 186.308        | 4.863   | 0.003 |
|                                 | Sample*TREATMENT        | 3            | 186.321        | 0.148   | 0.931 |
|                                 | INTAKE*Sample*TREATMENT | 3            | 186.322        | 2.002   | 0.005 |
| Sonic Deterrent Evaluation      | Intercept               | 1            | 4.035          | 132.885 | 0.000 |
|                                 | INTAKE                  | 1            | 4.143          | 13.083  | 0.021 |
|                                 | TREATMENT               | 1            | 7.274          | 3.447   | 0.104 |
|                                 | Sample                  | 3            | 41.190         | 2.170   | 0.106 |
|                                 | INTAKE*TREATMENT        | 1            | 7.190          | 0.025   | 0.878 |
|                                 | INTAKE*Sample           | 3            | 41.320         | 0.625   | 0.603 |
|                                 | Sample*TREATMENT        | 3            | 41.165         | 4.185   | 0.011 |
|                                 | INTAKE*Sample*TREATMENT | 3            | 41.315         | 0.136   | 0.938 |

## Case Studies – Laboratory Evaluations

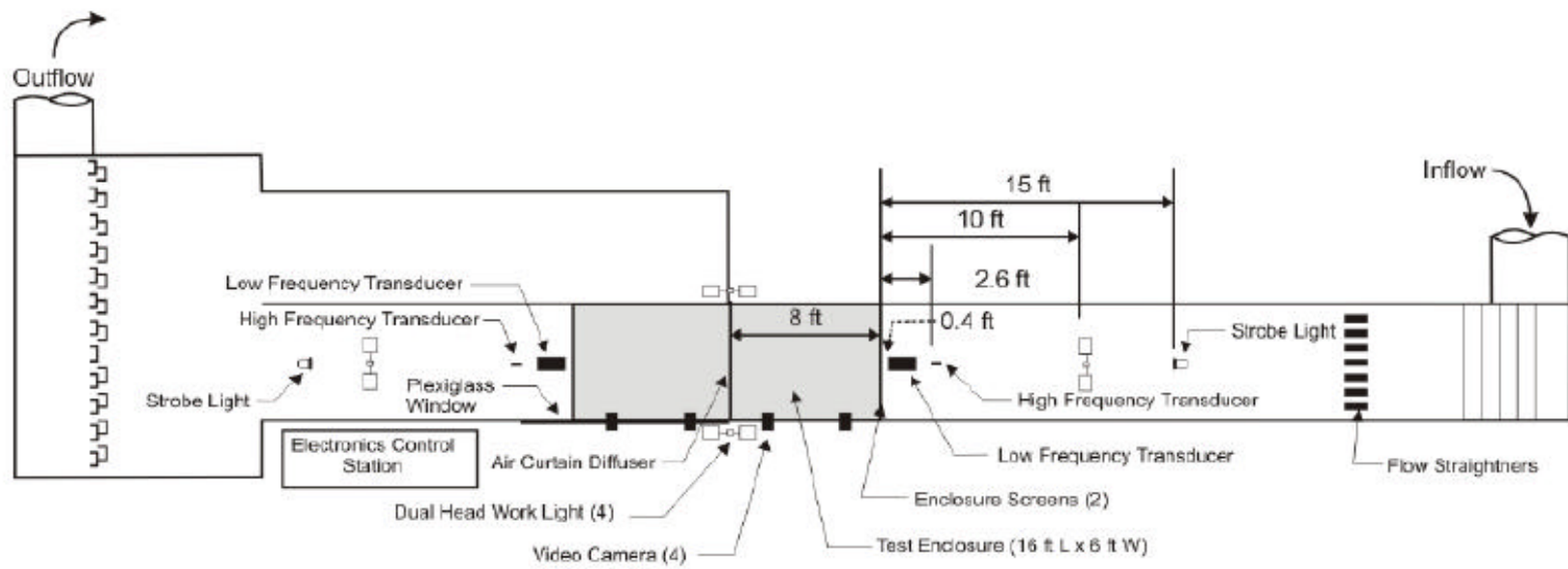
### ***Laboratory Study – PSEG/Alden Research Laboratory***

A comprehensive laboratory evaluation was conducted to investigate the effectiveness of behavioral deterrent technologies on commonly impinged species from the Delaware Bay in the vicinity of the Salem Nuclear Generating Station (Salem) (PSEG 2003). This laboratory study was the first phase of a three-phase study proposed by Salem in fulfillment of an NPDES permit requirement. Results of the Phase 2 field study are presented in a subsequent case study in this section.

A literature review encompassing hearing and vision capabilities of fish and the deterrent potential of strobe lights, sound, and air bubbles was conducted to aid in proper experimental

design. Based the results of this review and with input from experts in the field of sensory biology, the specific variables were selected.

Testing was conducted at Alden Research Laboratory in 2002 and 2003. Trials were conducted in a steel flume in flowing water (0.07 to 0.12 m/sec [0.25-0.40 ft/sec]). The test enclosure measured 4.9 by 1.8 m (16 by 6 ft) with water depths of 1.8 to 2 m (6 to 6.5 ft) (Figure 16-6) and was delineated by upstream and downstream isolation screens (500  $\mu$ m nylon mesh). The test enclosure was divided into four 1.2-m (4-ft) quadrants by painting lines on the floor and walls of the flume. The air bubble curtain was mounted on the floor in the middle of the enclosure between quadrants 2 and 3. The low frequency sound transducers were positioned outside of the test enclosure 12.2 cm (4.8 in) from the upstream and downstream isolation screens and at mid-depth in the water column. The high frequency sound transducers were positioned outside of the test enclosure 0.8 m (2.6 ft) from the upstream and downstream isolation screens and at mid-depth in the water column. The strobe lights were positioned 4.6 m (15 ft) from either isolation screen at mid-depth. Locations of the equipment are presented in Figure 16-6.



**Figure 16-6**  
**Overhead schematic of the test facility (PSEG 2003)**

The air bubble curtain was a Bio-Weave medium bubble diffuser with a pore size of 140  $\mu\text{m}$  and an operating range of 0.2 to 6.0  $\text{ft}^3$  air/min. The low frequency sound transducer (U.S. Navy J-11 amplified by an L6 amplifier, Instruments, Inc.) delivered a signal to weakfish (*Cynoscion regalis*), Atlantic croaker (*Micropogonias undulates*), and bay anchovy (*Anchoa mitchilli*) with the following components:

- 100-400 Hz broadband sound
- 100-400 Hz sweep
- Synthetic croak
- Authentic Atlantic croaker croak
- 500-3,000 Hz broadband noise
- 500-3,000 Hz sweep

The high frequency transducer (International Transducer Corporation Model 3406 amplified by an L6 amplifier, Instruments, Inc.) delivered a signal to blueback herring (*Alosa aestivalis*) with the following components:

- Dolphin click
- 80 kHz
- 90 kHz
- 100 kHz
- 120 kHz

During both low and high frequency testing, each signal component was 300 ms long with a 40-ms pause between signals. The entire signal sequences were repeated continuously with a 1-sec pause between transmissions.

The strobe lights (Flash Technology) were operated at a frequency of 300 flashes per min for all species except weakfish which received 360, and 450 flashes per min-treatments as well.

All of the fish for these trials were collected from the wild in Delaware Bay, temporarily held in tanks in Delaware, and transported to Alden Research Laboratory.

Groups of approximately 50 fish were allowed to acclimate to the test enclosure for 15 hrs before trials were conducted. Each trial consisted of four consecutive periods: a 10-min pretest baseline (without crowding), a 15-min pretest baseline (with crowding), a 15-min treatment, and a 10-min post-treatment. A pre-trial assessment was made regarding a groups' preferred location within the test enclosure. Then fish were crowded away from their preferred location before application of the treatment. The response to treatments was measured as the probability of a fish being deterred by a treatment from returning to its preferred location within the test enclosure. Each group of fish was exposed to a total of 8 treatments:

- Control
- Strobe light

- Sound
- Air bubble curtain
- Air and strobe
- Air and sound
- Air, strobe, and sound

Six replicates were conducted per treatment.

Fish positions were recorded in real time at 1-min intervals by counting numbers of fish in each quadrant. Additionally, fish positions were recorded with underwater digital cameras onto a hard drive for subsequent analysis. Video data were used to make counts of fish positions and distributions during three general time intervals. Immediate, extended, and prolonged responses were gleaned from counts made at 15 to 60 sec, 1 to 5 min, and 11 to 15 min, respectively. Maximum likelihood estimations (MLE) were used to estimate the probability of fish avoidance of each treatment condition.

Results with weakfish indicate that crowding may have had an effect on fish behavior in that fish tended to stay on the side of the enclosure to which they were crowded. During the 15 to 60-sec interval, weakfish displayed significant probabilities of avoidances (relative to control) to all treatments except the air only and air/sound treatments. During the 1 to 5-min interval, weakfish displayed significant probabilities of avoidance (relative to control) to air only and air/sound treatments. During the 11 to 15-min interval, weakfish displayed significant probabilities of avoidance (relative to control) to all treatments except strobe only. In fact, during the 1 to 5-min and 11 to 15-min intervals, weakfish displayed an attraction to the strobe light during strobe only treatments. Throughout all time intervals, no significant differences were noted among treatments. Rankings of the most effective treatments during each time interval are presented in Table 16-4.

Blueback herring generally exhibited avoidance behavior in the presence of combined stimuli. During the 15 to 60-sec interval, blueback herring displayed significant probabilities of avoidance (relative to control) to sound only, air/sound, and air/sound/light. During the 1 to 5-min interval, sound only, air/strobe, and air/sound/strobe treatments were significantly different from the control. During the 11 to 15-min treatments, strobe only and air/sound/strobe treatments were significantly different from the control. There were no significant differences among treatments in each interval except during the 1 to 5-min interval in which strobe/sound and air/sound/strobe treatments were significantly different from the four least effective treatments. Rankings of the most effective treatments during each time interval are presented in Table 16-4.

Atlantic croaker exhibited an avoidance behavior that did not diminish over time in the presence of the air bubble curtain. During the 15 to 60-sec interval, probabilities of avoidance in all treatments were significantly different from the control, but not significantly different from each other. During the 1 to 5-min and the 11 to 15-min intervals, croaker displayed avoidance probabilities significantly higher than the control for air only, strobe only, and sound/strobe treatments. Again, there were no significant differences in avoidance among the treatments in either of these time intervals. Rankings of the most effective treatments during each time interval are presented in Table 16-4.

Results of trials with bay anchovy indicate that there was a crowding effect. No data were recorded during the first 15 to 60-sec interval due to poor visibility. During the 1 to 5-min and 11 to 15-min intervals, anchovy displayed significant avoidance probabilities (relative to control) to the four treatments that included air. The treatments that did not include air did not elicit avoidance responses that were significantly different from the control. Data indicate that anchovy may have been attracted to the strobe only and strobe/sound treatments. Rankings of the most effective treatments during each time interval are presented in Table 16-4.

Additional tests were conducted to investigate the effect of strobe light intensity on the behavior alewife (*Alosa pseudoharengus*). Low, high and mid-intensity levels were accomplished by positioning the strobe lights as far as possible from the test enclosure, at the same location as the previous testing (4.6 m [15 ft] from the enclosure), and at the midpoint between the low and high positions, respectively. Alewife were initially disoriented by the strobe light and displayed a non-directional startle response. Probabilities of avoidance did not exceed 0.3 for any of the three intensity levels.

**Table 16-4**  
**Treatment effectiveness (i.e. ability to elicit avoidance) ranked from highest (1) to lowest (7) based on avoidance probabilities estimated for the three time intervals. Asterisks indicate statistically significant avoidance compared to the control probability of zero avoidance (P<0.05) (PSEG 2003).**

| Species          | Rank | 15-60 sec | 1-5 min | 11-15 min | Species          | Rank | 15-60 sec | 1-5 min | 11-15 min |
|------------------|------|-----------|---------|-----------|------------------|------|-----------|---------|-----------|
| weakfish         | 1    | S*        | ALS*    | AS*       | blueback herring | 1    | AS*       | ALS*    | S*        |
|                  | 2    | L*        | LS*     | LS*       |                  | 2    | L*        | LS*     | ALS*      |
|                  | 3    | LS*       | ALS*    | S*        |                  | 3    | ALS*      | AL*     | LS        |
|                  | 4    | AL*       | AS*     | A*        |                  | 4    | S*        | S*      | AL        |
|                  | 5    | ALS*      | ALS     | ALS*      |                  | 5    | AL*       | L       | L         |
|                  | 6    | AS        | S       | AL*       |                  | 6    | A*        | AS      | AS        |
|                  | 7    | A         | L       | L         |                  | 7    | LS*       | A       | A         |
| Atlantic croaker | 1    | AS*       | AS*     | AS*       | bay anchovy      | 1    | -         | AS*     | ALS*      |
|                  | 2    | L*        | ALS*    | ALS*      |                  | 2    | -         | ALS*    | AL*       |
|                  | 3    | ALS*      | AL*     | AL*       |                  | 3    | -         | AL*     | AS*       |
|                  | 4    | S*        | A*      | A*        |                  | 4    | -         | A*      | A*        |
|                  | 5    | AL*       | L*      | LS*       |                  | 5    | -         | S       | S         |
|                  | 6    | A*        | S       | S         |                  | 6    | -         | L       | LS        |
|                  | 7    | LS*       | LS      | L         |                  | 7    | -         | LS      | L         |

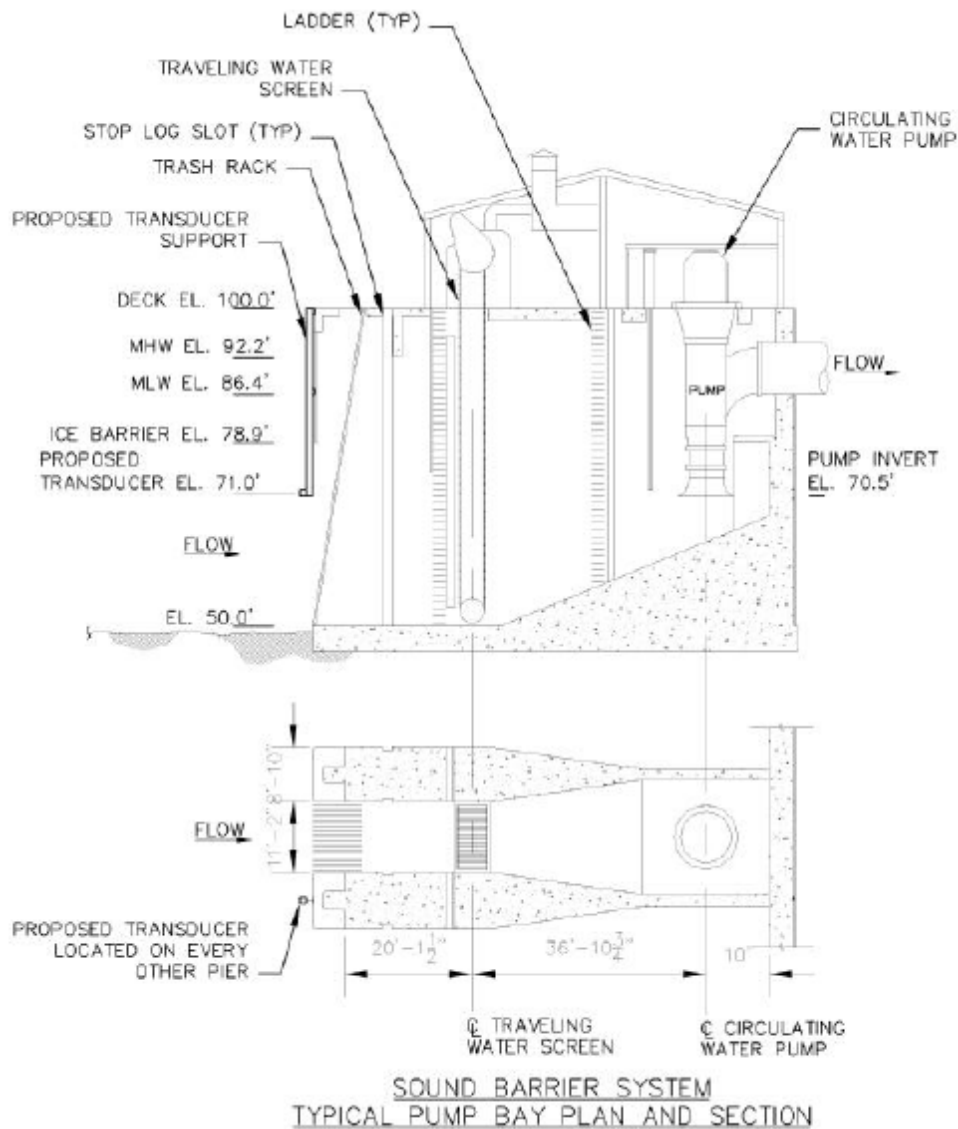
A = air; S = sound; L = strobe light; AS = air/sound; AL = air/strobe light; LS = strobe light/sound; and ALS = air/strobe/sound

It was concluded that each of the technologies displayed at least some deterrent potential for at least one of the species tested. Weakfish displayed the strongest avoidance response to air bubbles and low frequency (sonic) sound. Blueback herring displayed the strongest avoidance response to high frequency (ultrasonic) sound and strobe light. Atlantic croaker displayed the strongest avoidance response to air bubbles (alone and in combination with strobe light and sound) and strobe light. Bay anchovy displayed the strongest avoidance response to air bubbles (alone and in combination with strobe light and sound), and low frequency (sonic) sound. Efficacy of the particular technologies in the field, however, depends on a number of factors including ambient environmental conditions, cost, operation and maintenance.

The feasibility and potential biological efficacy of full-scale installations at the Salem CWIS were assessed. It was concluded, based on light transmissivity data, that high turbidity (<50 NTU) along with high approach velocities in the vicinity of the intakes would decrease the efficacy of a strobe light system. The feasibility of the air bubble curtain was assessed through the use of computational fluid dynamics (CFD). It was concluded that at high tidal velocities (~0.6 m/sec [2 ft/sec]), the integrity of the curtain would be compromised and could potentially allow the passage of fish. The design, installation, and operation of a sound system at the Salem intake would not be limited by the site-specific environmental conditions. Additionally, the sound system proved to be biologically effective, with all test fish displaying at least some response to sound treatments in the laboratory. Therefore, based on the engineering feasibility and potential biological effectiveness of each technology, the sound system was the only technology further considered in the detailed engineering feasibility assessment for use at the Salem intakes.

Proposed conceptual design for a sound system for the Salem intake would consist of 6 arrays with two transducers on each (low frequency and high frequency) positioned 12.2 m (40 ft) apart on every other intake pier (Figure 16-7). This sound system would not have any effect on the operation of the plant and would present a negligible amount of additional head loss in the system.





**Figure 16-7**  
**Section and overhead view of the proposed sound system at Salem (PSEG 2003)**

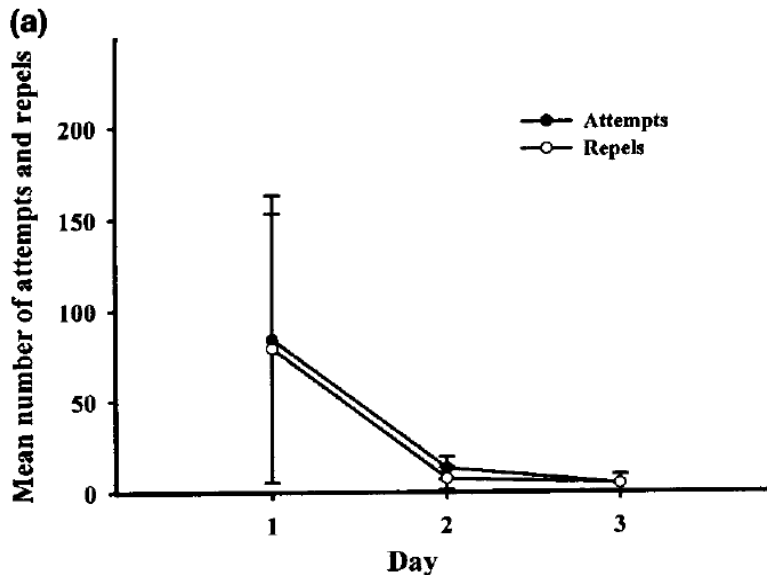
**Laboratory/Hatchery Facility, Illinois Department of Natural Resources**

A pneumatic sound generator coupled with an air bubble curtain (BioAcoustic Fish Fence – BAFF) was tested in outdoor raceway for its ability to prevent the passage of bighead carp (*Hypophthalmichthys nobilis*), a non-indigenous species that is establishing populations in the mid-western US. Tests were conducted in three concrete-sided raceways that were 24.7 by 2.4 by 1.8 m (81.0 by 7.9 by 5.9 ft). Each raceway contained one of the following: 1) a fully functional BAFF centered in the middle of the raceway, 2) a non-functioning BAFF centered in the middle of the raceway (to determine if any observed behavioral responses of the carp were a

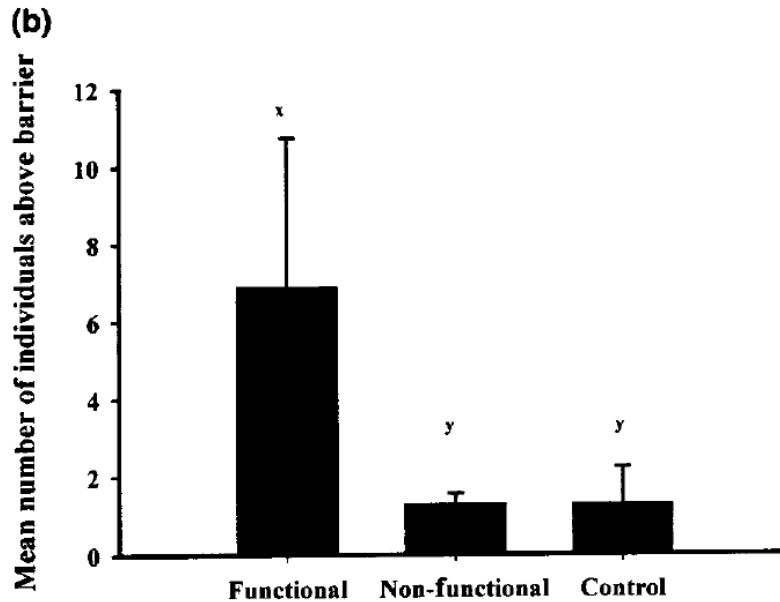
result of the presence of sound and air bubble equipment), or 3) a control raceway lacking any equipment.

Eleven bighead carp were introduced into each raceway and allowed to swim freely for 24-hrs before the beginning of each trial. At the beginning of each trial, the fish were physically contained at one end of the raceway. During the three-day trials, carp movements were observed for 6 hrs daily and the number of attempts to pass the barrier was recorded. During the course of the study, three replicates of each condition were tested. There was no flow in the raceways during testing. The sound signals used during the trials were random bursts in the 20 to 2,000 Hz range. Observed interactions with the barrier were classified as a repel (fish entered the array, then turned around and exited) or as a pass-through (fish entered the array, then crossing through the barrier). In addition to the numbers of repels and pass-throughs observed, the total number of fish on each side of the barrier was recorded every 15 min during the 6-hour observation period. Fish remaining on the initial side of the barrier were considered “above” the barrier, while those that passed through were considered “below” the barrier.

In the raceway with the functional array, 33 carp made 284 attempts to cross, but 95% were repelled. The number of attempts to pass the barrier decreased on the second and third day of testing as compared to the first day (Figure 16-8). The authors speculate that this reduction could have been a result of a learned avoidance behavior among the carp. The mean number of fish observed above the functional barrier was significantly greater than both the non-functioning barrier and the control ( $p < 0.001$ ), which were not significantly different from one another (Figure 16-9).



**Figure 16-8**  
Mean number ( $\pm$ SD) of bighead carp attempts and repels observed in the raceway with the activated sound and air system averaged across the three trials (adapted from Figure 1 in Taylor et al. 2005).



**Figure 16-9**

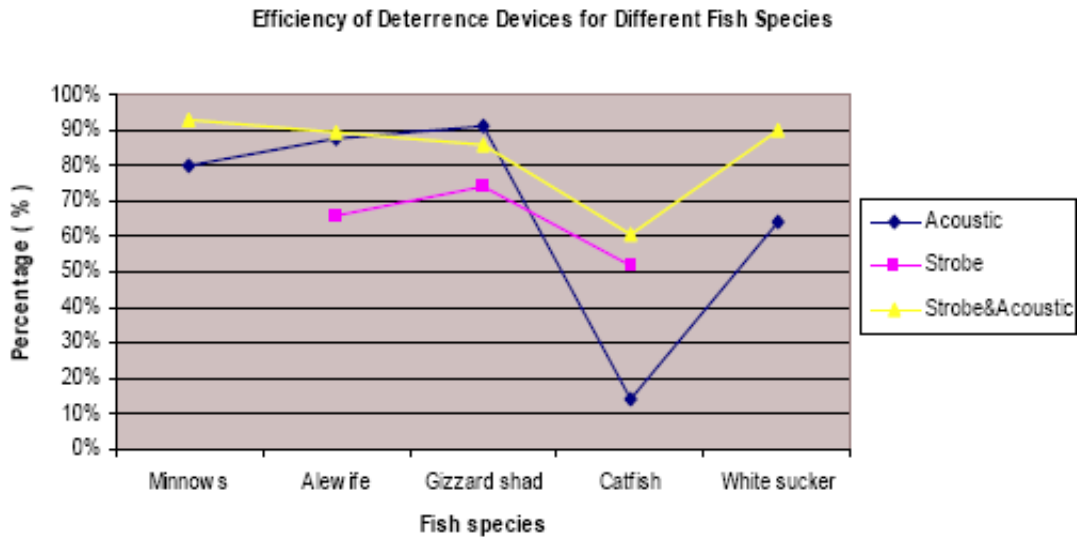
Mean number ( $\pm$ SD) of bighead carp found above the barrier. Different letters above the bars indicate significant differences in the analysis of variance (adapted from Figure 1 in Taylor et al. 2005).

### **Laboratory Study - Kinetics**

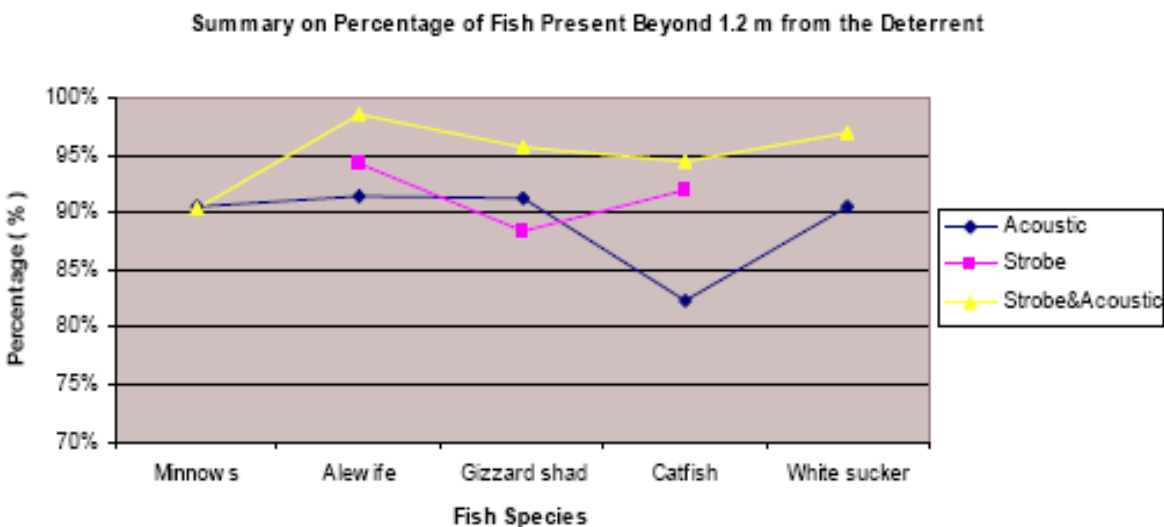
Laboratory experiments were conducted to evaluate the efficacy of an updated acoustic system (FGS, UK) both alone and in combination with strobe lights (Flash Technology, US). Testing was conducted in a 7 by 7 by 1.5 m (23 by 23 by 4.9 ft) test tank with a defined experimental zone of 3 to 4 m (9.8 to 13.1 ft) in length. Deterrent technologies were evaluated at two different flow rates, 0.1 and 0.5 m/sec. The flow was relied upon to bring fish into contact with the deterrent technologies. All test fish were collected from Lake Ontario, Lake Erie, or the St. Clair River. Fish were allowed to acclimate to the test tank for 48 hour before being released from an enclosure to begin the trial. Five replicate trials were conducted for each of the three conditions (sound alone, strobe alone, and sound and strobe together). Trials were 15 min in length and the number of fish per trial ranged from 15 individuals for the larger fish, such as gizzard shad (*Dorosoma cepedianum*), to 50 individuals for the smaller fish, such as minnows. Ambient light levels were low ( $<0.01 \mu\text{E}/\text{m}^2/\text{sec}$ ). Deterrence was measured as the number of times fish passed or avoided the deterrent equipment. Avoidance responses were also categorized based on the distance over which the response was elicited (0.6 or 1.2 m [2.0 or 4.0 ft]) (Patrick et al. 2006b).

Results of these trials are presented in Figure 16-10. The deterrent technologies were found to be species-specific with the pelagic species such as gizzard shad, alewife (*Alosa pseudoharengus*), and minnows being more consistently deterred by the acoustic system (over 80% effective), while demersal species such as brown bullhead (*Ameiurus nebulosus*) and white sucker (*Catostomus commersonii*) were less well deterred (15 and 64%, respectively). Although the strobe light system performed better than the sound system as a multi-species deterrent, species-specific effectiveness was consistently lower for many of the commonly impinged

species such as alewife, gizzard shad, and catfish. The highest effectiveness was achieved with the hybrid sound/strobe system in which combined species-effectiveness averaged 84%. Additional data were gathered on the effective deterrence distance provided by each technology. These data revealed that the hybrid system elicited a behavioral response that occurred over 1.2 m (3.9 ft) from the equipment 90% of the time (Figure 16-11) versus the shorter distance over which either individual technology elicited a behavioral response.



**Figure 16-10**  
Efficiency comparisons for deterrence devices for five species (Patrick et al. 2006b)



**Figure 16-11**  
Comparison of fish (5 species) positions beyond 1.2 m-zone from deterrence devices (Patrick et al. 2006b)

# 17

## OTHER FISH PROTECTION TECHNOLOGIES

### Introduction

There are other fish protection technologies that have had limited application at cooling water intake structures (CWIS). These technologies may be relatively new or ones that have been developed for other applications and have not yet been modified for installation at CWIS. The potential for future development of these technologies is uncertain.

### Inclined Plane Screen

The intent of the inclined plane screen is to divert fish upward in the water column and into bypasses. Several types of inclined plane screens have been investigated for diverting fish (primarily salmonids) upward to bypasses at hydroelectric facilities. In some cases, the screens are used to “skim” downstream migrants from surface waters of power pools. Once concentrated, the fish are transported to a release point. Their usefulness as part of a larger surface bypass and collection system is clear. Inclined screens have been reasonably successful in several applications at hydroelectric projects. However, this technology has not been used in a large-scale application to date and has not been considered available for application at CWISs.

### Filtrex Candles

The Filtrex Filter System (FFS) consists of filter elements approximately 12.7 cm (5 in.) long, 3.8 cm (1.5 in.) in diameter and made of plastic wafers stacked and fastened together with a central spring. Grooves between the stacked wafers provide filtration of 40  $\mu\text{m}$  (0.04 mm) and the flow capacity of each candle is approximately 18.9 lpm (5 gpm) at a headloss of 0.46 m (1.5 ft). Filter elements are assembled on tube sheets 0.61 by 0.61 m (2 by 2 ft) and separated by 0.91 m (3 ft) spacing rods. A total of 48 filter elements are arranged on each tube sheet and two tube sheets with spacer rods is considered an intake module (IMOD). The FFS is a relatively new fish protection technology that has not been applied to a CWIS. The biological efficacy of the FFS has been evaluated in the laboratory and in the field for possible application at the Taunton River desalination project in Dighton, MA.

### Case Studies – Field Applications

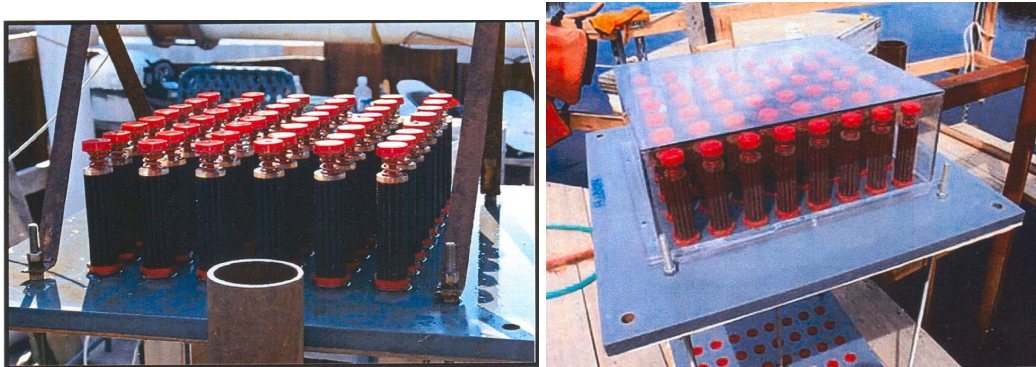
#### *Taunton River, Dighton, MA*

A field evaluation of the Filtrex Filter System (FSS) was conducted at the site of the desalination facility for which it has been proposed. The site is located on a tidally-influenced section of the Taunton River in Dighton, MA (Normandeau 2007).

The test facility was comprised a single intake module (IMOD) that contained 96 filter candles (Figure 17-1). Each filter candle was 11.7 cm (4.6 in.) long and was comprised of stacked plastic wafers with a pore size of 40  $\mu\text{m}$ . The candles are designed to operate at a through-pore velocity of 0.06 m/sec (0.2 ft/sec). The candles are also designed to be cleaned by either

stopping withdrawal or by backflushing. The proposed intake structure for the desalination facility will require 30 IMODs of 96 candles each (a total of 2,880 candles) to provide the 79,494 lpm (21,000 gpm) necessary to operate the facility.

The IMOD used for this study included a top and bottom sheet, each with an array of 48 candles installed. These sheets were inserted into an open receiver box such that they composed the top and bottom of the IMOD and were lowered into the river at a depth of two feet below mean low water. Entrainment samples were collected from the water drawn through the FSS in a 333- $\mu$ m plankton net. Impingement samples were collected by stopping flow through the filter array and capping the top 48 candles of the IMOD with an enclosure box to prevent the escape of impinged organisms (Figure 17-1). After being capped, the IMOD was raised out of the water and impinged organisms were rinsed into a collection tray. The bottom 48 candles remained uncapped during retrieval of the IMOD. Comparison between the number of organisms in the top (capped) sample and the bottom (uncapped) sample allowed the determination of how many impinged organisms are released when flow is stopped. Control samples were collected from an open port adjacent to the IMOD.



**Figure 17-1**  
Top candle array of IMOD shown with (left) and without (right) the impingement enclosure box (Normandeau 2007).



**Figure 17-2**  
**Filtrex receiver box of IMOD (Normandeau 2007)**

During entrainment sampling, a number of amphipods and five fish larvae were collected. The authors state that these entrained organisms likely entered the filter system through either leaks in the joints among various filter system components or by entering the common intake pipe during the times when the IMOD was removed for impingement sampling.

During impingent sampling, a total of 17 fish larvae and many amphipods were collected. No fish eggs were collected. The density of amphipods collected from the top and bottom candle arrays were 47,901 and 8,259 per  $m^3$  (1,691,608 and 29,1664 per  $ft^3$ ) of withdrawn water. This ratio of 5.8 to 1 in amphipod densities indicated that impinged, live invertebrates were released when flow was stopped.

A total of 15 species of ichthyoplankton were collected in control sampling. Fish eggs were only collected on two of the twenty-five sampling dates. The egg species were identified as river herring (*Alosa* spp.), white perch (*Morone americana*), and labrids (cunner and tautog). Total egg densities were 8.9 per  $m^3$  (314 per  $ft^3$ ) of withdrawn water. Total larval densities were 297 per  $m^3$  (10,489 per  $ft^3$ ) of withdrawn water. The most abundant larvae collected were seaboard goby (*Gobiosoma ginsburgi*) (29%), hogchoker (*Trinectes maculatus*) (20%), anchovy species (18%), river herring species (16%), and Northern pipefish (*Syngnathus fuscus*) (4%).

Sampling of ambient ichthyoplankton in the Taunton River near the desalination site was conducted in 2006. River herring and white perch accounted for 91% of the eggs and larvae collected between March and June. Based on ambient sampling data and impingement rates generated in a concurrent laboratory evaluation (see Alden 2007), a total of 7,271 herring eggs, 28,515 herring yolk-sac larvae, and 2,410 herring post yolk-sac larvae would potentially be lost to impingement (Table 17-1). A total of zero white perch eggs, 18,225 white perch yolk-sac larvae, and 471 post yolk-sac larvae would potentially be lost to impingement (Table 17-1).

**Table 17-1**  
**Impingement estimates for eggs, yolk-sac larvae (YSL), and post yolk-sac larvae (PYSL) of river herring and white perch (Normandeau 2007).**

| Life Stage           | Period Observed | Season Duration (days) | Geometric Mean Density per 100 m <sup>3</sup> | Total Number Encountering Intake in 6 hrs | Estimated Number Impinged (Daily) | Estimated Number Impinged (Season) |
|----------------------|-----------------|------------------------|-----------------------------------------------|-------------------------------------------|-----------------------------------|------------------------------------|
| <u>River Herring</u> |                 |                        |                                               |                                           |                                   |                                    |
| Egg                  | 04/27 - 06/08   | 42                     | 5.7                                           | 1,255                                     | 124                               | 7,271                              |
| YSL                  | 05/07 - 06/01   | 32                     | 4.3                                           | 955                                       | 636                               | 28,515                             |
| PYSL                 | 05/09 - 06/13   | 35                     | 0.4                                           | 79                                        | 49                                | 2,410                              |
| <u>White Perch</u>   |                 |                        |                                               |                                           |                                   |                                    |
| Egg                  | NA              | --                     | 0                                             | 0                                         | 0                                 | 0                                  |
| YSL                  | 05/07 - 06/15   | 39                     | 6                                             | 701                                       | 467                               | 18,225                             |
| PYSL                 | 05/07 - 06/15   | 39                     | 0.1                                           | 19                                        | 12                                | 471                                |

The general conclusions from this field evaluation included:

- Biofouling did not decrease the filtering capacity of the IMOD
- The number of impinged larvae collected was approximately 4% of the number collected in control samples
- The number of impinged amphipods collected was approximately 6% of the number collected in control samples
- Amphipod data indicated that live organisms impinged during filter operation were likely released when the filter flow was stopped
- It was calculated that the in-river filtering surface area encountered by eggs and larvae was 2.8% of the cross sectional area of the river
- It was estimated that equivalent adult losses of four age-one river herring and less than one age-one white perch would occur due to operation of the Filtrex Filter System

## **Case Studies – Laboratory**

### ***Alden Research Laboratory***

A laboratory study was conducted by Inima/Aquaria to investigate the impingement and subsequent survival of early life stages of fishes contacting Filtrex Filter Candles (FFS). This evaluation was a step in determining whether the FFS was an appropriate intake technology for a desalination facility. The FFS is composed of individual filter candles (Figure 17-3). The candles are designed with a pore size of 40 µm, a through-pore velocity of 0.06 m/sec (0.2 ft/sec), and a flow rate of approximately 35 lpm (9.25 gpm) (Alden 2007).



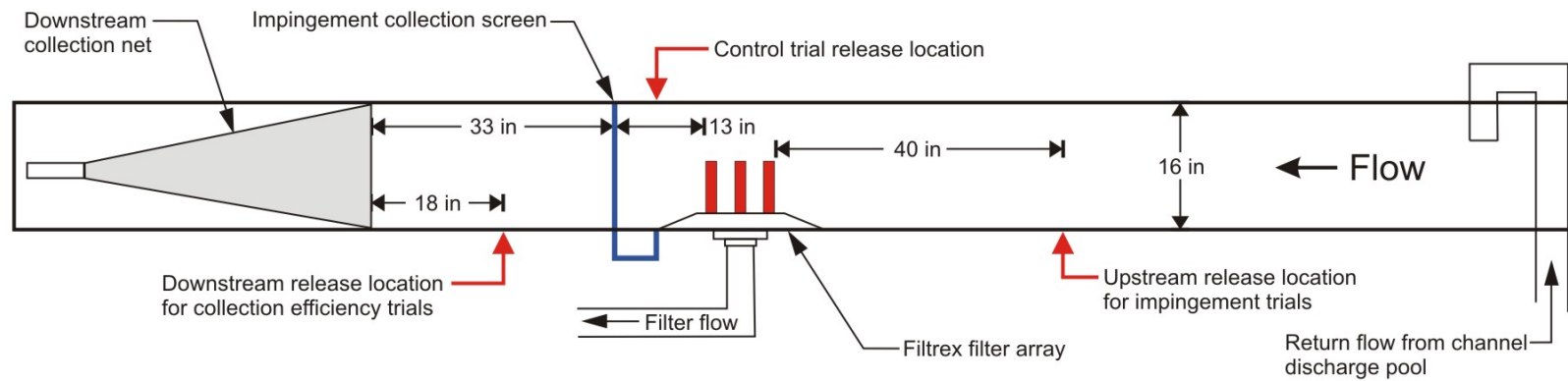


**Figure 17-3**  
**Six individual Filtrex filter candles installed in the laboratory test facility.**

The test facility was an acrylic flume measuring 20.3 cm (8 in.) wide, 40.6 cm (16 in.) deep, and 5.5 m (18 ft) long (Figure 17-4). An array of 6 Filtrex candles (two rows of three) was installed towards the downstream end of the flume. Water was pumped from a sump to supply the test flume. Channel velocity was set at 0.34 m/sec (1.1 ft/sec) for the majority of the trials. Flow was withdrawn through the filter candles by a separate pump at a total intake rate of 210.1 lpm (55.5 gpm). Eggs and larvae not impinging on filter candles were collected downstream in a 200- $\mu$ m mesh plankton net. Impinged organisms were collected in a 200- $\mu$ m collection box immediately downstream of the filter candle array. Two separate collections of impinged eggs and larvae were made. The first collection of impinged organisms was made after filter flow was ceased and the second collection was made when candles were back flushed. Water withdrawn by the filters was discharged through a 335- $\mu$ m plankton net to sample for any entrained organisms.

The species and life stages tested during this evaluation included blueback herring (*Alosa aestivalis*) (eggs and post yolk-sac larvae), alewife (*Alosa pseudoharengus*) (yolk-sac larvae), and American shad (*Alosa sapidissima*) (eggs and post yolk-sac larvae).

Trials were conducted by releasing 100 eggs or larvae upstream of the candle array and collecting impinged and bypassed organisms downstream. All impinged organisms were held for 48 hrs to assess latent impingement mortality. All treatment conditions were evaluated under clear water conditions. Additional trials with blueback herring eggs and larvae were conducted under turbid conditions (10 to 15 NTU) to determine the effects of debris and suspended solids on the impingement and survival of organisms.



**Figure 17-4**  
**Schematic with approximate distances between system components and egg and larvae release and collection locations and photograph of Filtrex Test Facility (Alden 2007)**

American shad eggs measured 3.1 mm (0.12 in.) in diameter and post yolk-sac larvae averaged 10.2 mm (0.4 in.) in length (mean) with a mean head capsule depth of 1.0 mm (0.04 in.). The mean impingement rate for shad eggs was 7.4% (includes fish not accounted for after trial), indicating that 92.6% of eggs passed downstream without impinging. All impinged eggs were recovered after filter flow was ceased, none after backflushing. Immediate survival of impinged eggs was 100% (Table 17-2). Immediate survival of eggs collected downstream was 99.2%. Forty eight-hour latent survival for impinged eggs and those collected downstream were 90.9 and 68.7%, respectively (Table 17-2). Survival of controls indicated that collection in the downstream net was most likely responsible for the higher mortality observed.

**Table 17-2**

**Survival rates for American shad eggs. Collection locations are downstream net (DSN) and impingement collection screen (ICS) with no filter flow (NF). Trial types are impingement (I), control (C), and handling control (HC). Downstream net controls were released between the candles and the net and impingement collection screen controls were released between the candles and the screen with the filter flow off. Survival rates include hatched larvae and live eggs. Total survival is calculated by multiplying immediate survival by 48-hour survival.**

| Collection Location | Trial Type | Immediate Survival (%) | 48-hr Survival (%) | Total Survival (%) |
|---------------------|------------|------------------------|--------------------|--------------------|
| DSN                 | I          | 99.2                   | 68.7               | 68.1               |
| DSN                 | C          | 97                     | 40.6               | 39.4               |
| ICS - NF            | I          | 100                    | 90.9               | 90.9               |
| ICS                 | C          | 100                    | 99                 | 99                 |
| --                  | HC         | --                     | 95                 | 95                 |

The mean impingement rate for post yolk-sac shad larvae was 10.1%, indicating that 89.9% of larvae passed downstream without impinging. Of the impinged larvae, 64% were recovered after the filter flow was ceased and 36% after backflushing. Immediate survival of post yolk-sac shad larvae was 0% (Table 17-3). Immediate survival of larvae collected downstream and in the impingement collection net were 0 and 77.8%, respectively. Forty eight-hour latent survival for impinged larvae and those collected downstream were 13 and 0%. Total survival of impinged larvae was 10.1% (Table 17-3).

**Table 17-3**

**Survival rates for American shad larvae. Collection locations are downstream net (DSN) and impingement collection screen (ICS) with no filter flow (NF). Trial types are impingement (I), control (C), and handling control (HC). Downstream net controls were released between the candles and the net; impingement collection screen controls were released between the candles and the screen with the filter flow off. Total survival is calculated by multiplying immediate survival by 48-hour survival.**

| <b>Collection Location</b> | <b>Trial Type</b> | <b>Immediate Survival (%)</b> | <b>48-hr Survival (%)</b> | <b>Total Survival (%)</b> |
|----------------------------|-------------------|-------------------------------|---------------------------|---------------------------|
| DSN                        | I                 | 11.4                          | 3.2                       | 0.4                       |
| DSN                        | C                 | --                            | --                        | 0                         |
| ICS - NF                   | I                 | 0                             | --                        | 0                         |
| ICS - BF                   | I                 | 0                             | --                        | 0                         |
| ICS                        | C                 | 77.8                          | 13                        | 10.1                      |
| --                         | HC                | --                            | 73                        | 73                        |

Blueback herring eggs used in this evaluation measured 1.1 mm (0.04 in.) in diameter. The mean impingement rates for blueback herring eggs during clear and turbid water trials were 7.8 and 5.8%, respectively (includes fish not accounted for after trial). For clear water trials, 18% of impinged eggs were recovered after the filter flow was ceased and 82% after backflushing. Immediate survivals of bypassed and impinged fish were 95.1 and 100%, respectively during clear water trials (Table 17-4). Immediate survivals of bypassed and impinged fish in turbid water trials were lower than in clear water trials (Table 17-4). The impingement data indicated that suspended solids and debris does not increase impingement rates.

**Table 17-4**

Survival rates for blueback herring eggs tested with clear and turbid water. Collection locations are downstream net (DSN) and impingement collection screen (ICS) with no filter flow (NF). Trial types are impingement (I), control (C), and handling control (HC). Downstream net controls were released between the candles and the net; impingement collection screen controls were released between the candles and the screen with the filter flow off. Total Survival is calculated by multiplying immediate survival by 48-hour survival. Survival data was not recorded for downstream net controls (i.e., only collection efficiency numbers were recorded).

| Collection Location               | Trial Type | Immediate Survival (%) | 48-hr Survival (%) | Total Survival (%) |
|-----------------------------------|------------|------------------------|--------------------|--------------------|
| <i><u>CLEAR WATER TRIALS</u></i>  |            |                        |                    |                    |
| DSN                               | I          | 95.1                   | 98.8               | 93.9               |
| DSN                               | C          | --                     | --                 | --                 |
| ICS - NF                          | I          | 100                    | 0                  | 0                  |
| ICS - BF                          | I          | 100                    | 77.8               | 77.8               |
| ICS                               | C          | 97                     | 87.5               | 84.8               |
| --                                | HC         | --                     | 87                 | 87                 |
| <i><u>TURBID WATER TRIALS</u></i> |            |                        |                    |                    |
| DSN                               | I          | 94.4                   | 96.6               | 91.2               |
| DSN                               | C          | --                     | --                 | --                 |
| ICS - NF                          | I          | 50                     | 100                | 50                 |
| ICS - BF                          | I          | 88.9                   | 87.5               | 77.8               |
| ICS                               | C          | 98.8                   | 97.6               | 96.4               |
| --                                | HC         | --                     | 87                 | 87                 |

Alewife larvae were only tested in clear water. These yolk-sac alewife larvae measured 3.9 mm in length and had a head capsule depth of 0.6 mm. Collection efficiency trials indicated that a large proportion of the yolk-sac alewife larvae were impinging on the candles during testing and not dislodging effectively during backflushing. The resulting impingement rate was, therefore, high (58.1%)0

Blueback herring larvae were tested in both clear and turbid water. The post yolk-sac blueback herring larvae averaged 5.6 and 6.7 mm in length (mean) during clear water trials and 6.9 mm during turbid water trials. Head capsule depths were 0.5 and 0.6 mm for the larvae used in the clear and turbid water trials, respectively. The mean impingement rates for blueback herring larvae tested in clear water were 15.3 and 11.1%, respectively, for the 5.6-mm fish and the 6.7-mm fish. For turbid water trials, the mean impingement rate was 13.1%. Considering the high impingement rate for yolk-sac alewife (58.1%), these data indicated that larger post yolk-sac

river herring would likely be impinged at a substantially lower rate. In these trials with river herring (blueback herring and alewife combined), 39% of impinged fish were recovered after filter flow was ceased and 61% after backflushing. Immediate survival for bypassed fish did not exceed 1.7% for either species (Table 17-5). Controls indicated that mortality of bypassed fish was likely caused by collection in the downstream net. Total survival of impinged larvae was 0% for blueback herring larvae under all testing conditions and 33% for alewife larvae (Table 17-5). Controls indicated that alewife mortality was likely caused by impingement, while two-thirds of blueback herring mortality was likely caused by the collection process. Testing under both water conditions indicated that suspended solids and debris did not affect egg or larval impingement rates.

**Table 17-5**

**Survival rates for alewife and blueback herring larvae tested with clear and turbid water.**

**Collection locations are downstream net (DSN) and impingement collection screen (ICS) with no filter flow (NF). Trial types are impingement (I), control (C), and handling control (HC). Downstream net controls were released between the candles and the net; impingement collection screen controls were released between the candles and the screen with the filter flow off. Total Survival is calculated by multiplying immediate survival by 48-hr survival. A handling control trial was not conducted for alewife larvae.**

| Collection Location                                                         | Trial Type | Immediate Survival (%) | 48-hr Survival (%) | Total Survival (%) |
|-----------------------------------------------------------------------------|------------|------------------------|--------------------|--------------------|
| <b>ALEWIFE YOLK-SAC LARVAE - CLEAR WATER TRIALS</b>                         |            |                        |                    |                    |
| DSN                                                                         | I          | 1.7                    | 0                  | 0                  |
| DSN                                                                         | C          | 0                      | --                 | 0                  |
| ICS - NF                                                                    | I          | 33.3                   | 100                | 33.3               |
| ICS - BF                                                                    | I          | 0                      | --                 | 0                  |
| ICS                                                                         | C          | 100                    | 99                 | 99                 |
| <b>BLUEBACK HERRING POST YOLK-SAC LARVAE (5.6 MM) - CLEAR WATER TRIALS</b>  |            |                        |                    |                    |
| DSN                                                                         | I          | 0                      | --                 | 0                  |
| DSN                                                                         | C          | 0                      | --                 | 0                  |
| ICS - NF                                                                    | I          | 0                      | --                 | 0                  |
| ICS - BF                                                                    | I          | 0                      | --                 | 0                  |
| ICS                                                                         | C          | 32.9                   | 14.8               | 4.9                |
| --                                                                          | HC         | --                     | 65                 | 65                 |
| <b>BLUEBACK HERRING POST YOLK-SAC LARVAE (6.7 MM) - CLEAR WATER TRIALS</b>  |            |                        |                    |                    |
| DSN                                                                         | I          | 0                      | --                 | 0                  |
| DSN                                                                         | C          | 0                      | --                 | 0                  |
| ICS - NF                                                                    | I          | 0                      | --                 | 0                  |
| ICS - BF                                                                    | I          | 0                      | --                 | 0                  |
| ICS                                                                         | C          | 36.1                   | 65.7               | 23.7               |
| --                                                                          | HC         | --                     | 84                 | 84                 |
| <b>BLUEBACK HERRING POST YOLK-SAC LARVAE (6.9 MM) - TURBID WATER TRIALS</b> |            |                        |                    |                    |
| DSN                                                                         | I          | 0                      | --                 | 0                  |
| DSN                                                                         | C          | 0                      | --                 | 0                  |
| ICS - NF                                                                    | I          | 0                      | --                 | 0                  |
| ICS - BF                                                                    | I          | 0                      | --                 | 0                  |
| ICS                                                                         | C          | 39.1                   | 80.6               | 31.5               |
| --                                                                          | HC         | --                     | 89                 | 89                 |

The author suggested that the FSS performed well in this laboratory study. Low impingement rates for most species/life stages may have resulted from a high channel velocity to through-pore velocity ratio, which has been shown to increase the biological performance of other intake screens such as cylindrical wedgewire screens. It was also noted that only a small portion of the entire population of individuals will encounter the system and even a smaller portion will be impinged, therefore, the overall impact of impingement mortality on fish populations should be minimal.

## **Guidance Walls**

Guidance walls are used as physical means to divert fish and usually consist of concrete structures that are partially submerged and angled toward a bypass. The concept generally is designed for anadromous out-migrants that travel in the upper portions of the water column in hydroelectric project forebays.

The use of guidance wall structures can be an effective means to divert anadromous out-migrants to bypasses. Diversion effectiveness will be dependent on fish behavior and local hydraulic conditions. A guidance wall installed at the Vernon Project on the Connecticut River has been shown to be very effective in diverting Atlantic salmon (*Salmo salar*) smolts to a surface bypass (i.e., log/ice sluice). A similar guidance wall at the Bellows Falls Project on the Connecticut River achieved a guidance efficiency of 94.4% for a group of 144 radio-tagged fish (Normandeau 1996a, b). Guidance walls have only been used at hydroelectric projects. Additional research associated with fish behavior and hydraulic conditions in relation to the ability of guidance walls to successfully divert fish may increase the use of such structures at both hydroelectric projects and potentially cooling water intake structure (CWIS).

## **Turbulence**

A relatively new development in behavioral barrier guidance is the potential use of turbulent attraction flows to guide fish. The concept, though designed primarily for use in guiding out-migrating salmon smolts in hydroelectric project forebays, has implications for application at any water intake where the protection of fish has become a concern (i.e., CWISs). The concept is based upon the successful use of attraction flows to guide migrating fish to fishway entrances. The reasoning then followed that turbulent flows could be induced and used to guide fish in other situations. Coutant (2001) gives an overview account of the inception and theoretical development of turbulence as a guidance device.

The induction of turbulent flows can be achieved either actively or passively. Active induction involves the generation of turbulence through the use of technologies such as submerged water jets or propellers. Passive induction makes use of natural velocities to generate turbulence by placing structures (e.g., submerged vanes and berms, pilings, concrete cylinders) in strategic locations in the existing flow field. The approach taken to induce flows would depend on the site-specific flow characteristics of the waterbody being considered. If the flows maintain a relatively high velocity, a passive turbulence induction device may be used, whereas if relatively low velocity flows are present, an active induction device would be necessary.

Currently, this behavioral guidance technology is considered theoretical and has not undergone extensive laboratory or field testing. The few studies that have been conducted have revealed the potential for induced turbulence to effectively guide fish. An evaluation of the use of induced



turbulence to improve the bypass efficiency of a surface bypass collector at the Penacook Hydroelectric Project on the Contoocook River was conducted in 1997 and 1998 (Truebe and Truebe, 1997 and 1998). Low surface bypass efficiencies were caused by the absence of adequate surface flow into the bypass entrance. Two 2 hp outboard motors with 1 m diameter propellers were used to generate a turbulent flow that was directed toward the surface bypass entrance. With the use of the induced turbulent flow, bypass efficiencies were calculated to be 80 and 93% (stated to be an improvement over past bypass efficiencies).

Another evaluation of induced turbulence in guiding Pacific salmon was conducted in 1999 at the Cowlitz Falls Dam in Washington (Darland et al. 2001). Using a similar propeller setup, juvenile salmon were successfully guided from the north to the south side of the project forebay. Tracking with radio telemetry and split-beam hydroacoustics during propeller on/propeller off testing supports this conclusion.

Initial reluctance to the use of induced turbulence for fish guidance was based on research describing the damaging effects of intense turbulence (i.e., sheer stress) generated by high-pressure water jets. However, research with angled bar racks and louver arrays indicate the potential for turbulence to successfully guide fish to bypasses (EPRI 2001). Current theoretical designs of turbulence guidance systems attempt to create a trail of turbulent flow along which fish would guide. The use of current computer modeling programs such as computational fluid dynamics (CFD) could facilitate the development and design of turbulent attraction flows for fish guidance.

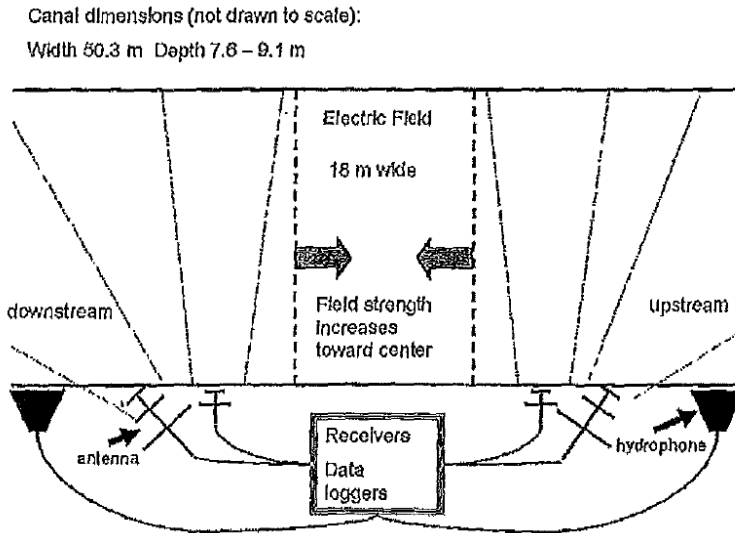
## **Electric Barriers**

Electric barriers have been shown to effectively prevent the upstream passage of fish. However, attempts to divert or deter the downstream movement of fish have met with limited success (Bengeyfield 1990; Kynard and O'Leary 1990). Consequently, past evaluations have not lead to permanent applications. Electric screens that use DC current have been used to prevent passage of fish at relatively low flow intakes (e.g. irrigation canals) and to prevent upstream passage of invasive fish species. The potential effectiveness of these barriers for application at cooling water intake structures (CWISs) is unknown. Given their past ineffectiveness and hazard potential, electric screens are not considered a viable technology for application at CWISs.

## **Case Studies – Field Evaluation**

### ***Chicago Sanitary and Shipyard Canal***

The U.S. Army Corps of Engineers (USACE), authorized by the National Invasive Species Act of 1996, conducted a feasibility investigation of an electric barrier at the Chicago Sanitary and Shipyard Canal to determine its effectiveness in dispersing nuisance species (Sparks et al 2010; Moy et al 2011; and Savino et al. 2001). Multiple barriers were screened by considering installation constraints, cost-effectiveness, environmental impact, use of available technology, and the need to operate continuously. Barrier approaches considered included filtration, ultraviolet light, heating, electricity, electromagnetic field, bubble screens, acoustic arrays, low dissolved oxygen, habitat alteration, and operation and flow changes. The electric barrier best represented the criteria for this site. A demonstration barrier was created and evaluated for effectiveness of deterring upstream movements of common carp (*Cyprinus carpio*).



**Figure 17-5**  
**Arrangement of antennas and hydrophones at the barrier (Sparks et al. 2010)**

A total of 130 common carp were used in this study, all greater than 30 cm (11.8 in.) in total length and 950 g (2.1 lbs) in weight. They were equipped with surgically implanted radio/acoustic transmitters and released 20 m (65.6 ft) downstream of the electrical barrier. Radio antennas at the site of the barrier were installed to detect the approach of the carp. To detect acoustic signals, holes were drilled into the canal wall and fitted with hydrophones.

Of the 130 common carp released, only one was found crossing the barrier and 118 stayed well downstream of the barrier and above the Lockport Lock and Dam. Although these results seem favorable, the crossing occurred during the transitioning of a tow boat past the barrier, which brings into question the effects of navigation on the integrity of the barrier.

### **Lake Seminole, Georgia**

A monitoring program evaluating the effectiveness of two physical barriers and an electric barrier was conducted at two embayments in the Seminole River, Georgia (Maceina et al 1999).

Two V-shaped barriers were installed at the entrances of Fish Pond Drain and two gate barriers were installed at the entrance of Cypress Pond. A total of 272 triploid grass carp (*Ctenopharyngodon idella*) ranging from 362 to 915 mm (14.3 to 36 in.) were fitted with radio tags and periodically released throughout the study of the physical barriers. Tests were conducted from December 1995 through September 1997 to determine the effectiveness of these physical barriers. A total of 119 and 64 fish were released at Fish Pond Drain and Cypress Pond, respectively.

An electric barrier was installed in December 1997 at one of the V-shaped barriers in Fish Pond Drain. It was designed by Smith-Root Company, set at a peak current output of 12 A at a 10-ms pulse over a 500-ms duty cycle for an average current of 1.44 A. A total of 84 tagged fish were released in December 1997. Movements were monitored for 13 months.

The average annual confirmed escape rate for the V-shaped funnel barriers and the gated barriers were 9% and 23%, respectively. These percentages were based on the mean monthly fish remaining alive and accounted for within the confined areas. Missing or dead fish and tag

malfunctions during physical barrier evaluations were high throughout, accounting for 46% of fish released in Fish Pond Drain and 76% in Cypress Pond. During the evaluation of the electric barrier, all but one fish was successfully monitored. There was no observed escapement by the electrical barrier.

The authors concluded that the electric barrier was more effective than the physical barriers at confining triploid grass carp in embayments of Lake Seminole. Although effective during this application, the electric barrier may not be applicable at cooling water intake structures where velocities are likely higher.

### ***Jordan River, Michigan***

A field study evaluating the effectiveness of a pulse-DC electrical barrier at blocking migration of sea lamprey (*Petromyzon marinus*) was conducted in the Jordan River, Michigan (Swink 1999).

Mark and recapture methods were used to track movement passed the barrier. The settings of the barrier was initially set to a 1-ms pulse width at a pulse rate of 10 pulses/sec, but was increased to a 2-ms pulse width after the collection of a lamprey passing the barrier. Captured migrating female sea lamprey (*Petromyzon marinus*) were tagged with a Dennison tag and a coded wire tag in the dorsal musculature. Lamprey were then released at two locations, one 50 to 200 m (164 to 656.2 ft) upstream of the barrier and one at Rodger's bridge, about 1.1 km (0.68 mi) downstream of the barrier. A fyke net was deployed 3.2 km (2 mi) upstream of the barrier to capture any upstream moving fish. Collections were recorded with the barrier on and the barrier off. Two portable assessment traps were also set downstream of a dam on Deer Creek, a tributary of the Jordan River, to capture lamprey blocked by the barrier looking downstream for a spawning location, a behavior labeled "straying."

There were a total of 14 releases of about 300 fish, seven releases at each site. Of the 2,093 fish released at the upstream site, 446 were collected upstream while the barrier was on and two were collected upstream with the barrier off. Of the 2,094 fish released at the downstream site, one was collected upstream while the barrier was on at the lower power setting and eight were collected while the barrier was off. Straying behavior was observed in 39 lamprey being captured in the traps in Deer Creek.

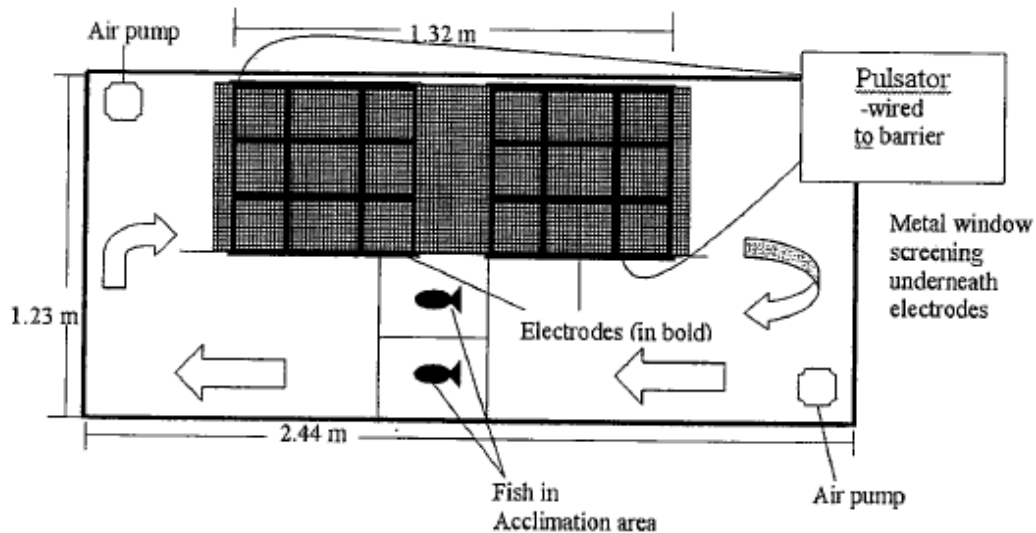
The authors conclude that the electrical barrier successfully blocked the migration of spawning phase sea lamprey. The pulse-DC barrier would be preferable to small, low-head barriers, limiting impoundment.

### ***Case Studies – Laboratory Evaluation***

A laboratory study was conducted at the Eastern Michigan University Aquatic Research Facility to evaluate the efficacy of electric and air bubble barriers on the movement of Eurasian ruffe (*Gymnocephalus cernuus*). Experimental fish were collected by bottom trawling from Duluth Harbor in Lake Superior, transported to the test facility, and held in 100-L (26.4 gal) tanks for acclimation. Experimental fish for the electric barrier trials were 10 to 14 cm (4 to 5.5 in.) in length, while those for the bubble barrier were 6.0 to 9.9 cm (2.4 to 3.9 in.) (Dawson et al. 2006).

Electric barrier trials were held in tanks measuring 244 cm (96 in.) long by 123 cm (48.4 in.) wide by 61 cm (24 in.) deep with a water depth of 41 cm (16.1 in.). A caged acclimation area

was separated from the electric barrier by a plastic wall and was sufficiently sized to allow acclimation of two fish at once. Water temperature and conductivity were 10 degree Celsius (50 degrees Fahrenheit) and 500  $\mu\text{S}/\text{cm}$ , respectively. Pumps provided a circular flow through the test tank. The electric barrier consisted of zinc-plated steel bars arranged in two 51 by 56 cm (20.1 by 22 in.) crosshatch patterns that were covered with metal window screening (Figure 17-6). An electric pulsator (Smith-Root, Inc.) was used to deliver the charges. Computer interface software allowed control of the pulse frequency, duration, and voltage (upper voltage limit of 100 V).



**Figure 17-6**  
**Overhead schematic of electric barrier test facility (Dawson et al. 2006)**

Initial trials were run to identify the most effective of four electrical settings. The four pulse duration/pulse frequency settings evaluated were 3 ms/6 Hz, 5 ms/6 Hz, 10 ms/6 Hz, and 20 ms/4 Hz, all of which had an output of 100 V. Fish that had been acclimated to the test facility for 24 hour were released from the cage and the barrier was energized. Trials ran for 90 min and all interactions with the barrier were recorded as “pass”, “repel”, or “stun”. A minimum of 12 replicates were run for each barrier setting and for the control (electric barrier off).

Subsequent trials evaluated the efficacy of this barrier with fish motivated to migrate across the barrier by the presence of food or shelter. Motivation with food was accomplished by presenting a small amount of food (bloodworms and rainbow trout eggs [*Oncorhynchus mykiss*]) on the opposite side of the barrier from the fish. Fish were starved for two weeks prior to this experimental treatment. Motivation with shelter was accomplished by presenting a shaded area on the side (approximately one quarter the ambient light intensity) of the barrier opposite the fish. Each of these 90-min heightened motivation treatments was replicated 12 times; controls 4 times.

The efficacy of an air bubble barrier was also evaluated in a tank that was divided by screening into three enclosures measuring 225 cm (88.6 in.) long by 30.5 cm (12 in.) wide by 61 cm (24 in.) deep with a water depth of 41 cm (16.1 in.). Air was pumped through 6.4 mm (0.25-in.) diameter PVC pipe to supply 25 cm<sup>3</sup>/sec to produce the bubble barrier. Two hole sizes (0.4 and

1.0 mm [0.02 to 0.04 in.]) and two hole densities (15.9- and 31.8-cm spacing [6.25- and 12.5-in. spacing]) were evaluated. Fish were acclimated for a minimum of 12 hour prior to testing. Trials ran for 90 min and all interactions with the barrier were recorded as “pass” or “repel”. Each experimental condition was replicated eight times; controls 4 times.

The initial trials revealed that the most effective electric barrier setting was 5 ms/6 Hz which produced significantly more “repels” than the other settings or the control. Additionally, the higher settings of 10 ms/6 Hz and 20 ms/4 Hz “stunned” significantly more fish than the lower settings. It was therefore concluded that the 5 ms/6 Hz setting would be used for the heightened-motivation trials. The inclusion of motivation (food or shelter) in the electric barrier trials did not result in any significant differences in deterrence over the non-motivated fish. The bubble barriers did not significantly repel fish over controls (no bubble treatments). Additionally, there were no significant differences in the number of “repels” among the different hole size and density combinations.

Based on the results of this study, it was concluded that neither the electric barrier nor the bubble barriers evaluated in this study were effective in controlling the movement of European ruffe.



# 18

## REFERENCES

Adams, C. 2006. Personal communication between C. Adams, Entergy and G. Allen, Alden Research Laboratory, Inc.

AKRF, Inc. 2010. Assessment of the efficacy of a small-scale 2.0-mm cylindrical wedgewire screen unit for reducing entrainment densities of fish larvae in Haverstraw Bay. Prepared for United Water New York, Inc.

Alden Research Laboratory, Inc. (Alden). 1976. Hydraulics of Flow through Porous Gravel Structures New England Power Service Company. Prepared for New England Power Service Company.

Alden Research Laboratory, Inc. (Alden). 2000. Preliminary Study Results Improving the Debris Handling Capabilities of the Salem Traveling Water Screens. Prepared for Public Service Electric and Gas Company.

Alden Research Laboratory, Inc. (Alden). 2006. Laboratory Evaluation of Hydrolox Screens.

Alden Research Laboratory, Inc. (Alden). 2007. Laboratory Evaluation of Filtrex Filter System for Protecting Ichthyoplankton at a Desalination Facility intake.

Alden Research Laboratory and Stone & Webster Engineering Corporation. 1996. Evaluation of the Modular Inclined Screen (MIS) at the Green Island Hydroelectric Project: 1996 Test Results. Prepared for Niagara Mohawk Power Corporation and New York State Energy Research and Development Authority.

Alden Research Laboratory, Inc. 2010. Evaluation of the biological efficacy of 2.0-mm wedgewire screens in the Hudson River. Prepared for AKRF, Inc.

Alden Research Laboratory, Inc. 2012a. Laboratory evaluation of the Beaudrey WIP screen for protection of early life stages of fish at the Taunton River Desalination Plant. Prepared for Aquaria Water, LLC.

Alden Research Laboratory, Inc. 2012b. Phase II laboratory evaluation of the Beaudrey WIP screen for protection of early life stages of fish at the Taunton River Desalination Plant. Prepared for Aquaria Water, LLC.

Alevras, R.A. 1974. Status of air bubble fish protection system at Indian Point Station on the Hudson River. From: Second National Workshop on Entrainment and Impingement, 1974.

Amaral, S. V., F. C. Winchell, B. J. McMahon and E. P. Taft. 1998. Evaluation of Behavioral Guidance Technologies for Diverting Chinook Salmon Smolts at the Roza Dam Screening Facility. Prepared for the Yakima/Klickitat Fisheries Project.

Amaral, S. V., E. P. Taft, F. C. Winchell, A. Plizga, E. Paolini, and C. W. Sullivan. 1999. Fish Diversion Effectiveness of a Modular Inclined Screen. Pages 61-78 *in* M. Odeh, editor. Innovations in Fish Passage Technologies. American Fisheries Society, Bethesda, Maryland.

- Amaral, S. V., F. C. Winchell, and T. N. Pearsons. 2001. Reaction of Chinook Salmon, Northern Pike, and Smallmouth Bass to Behavioral Guidance Stimuli. Pages 125-144 *in* C. Coutant, editor. Behavioral Technologies for Fish Guidance. American Fisheries Society, Symposium 26, Bethesda, MD.
- Amaral, S. V., J. L. Black, and D. A. Dixon. 2002a. Assessing Guidance Efficiency of Angled Bar Racks and Louvers. Hydro Review, June 2002, HCI Publications, St. Louis, Missouri.
- Amaral, S. V., J. L. Black, B. J. McMahon, and D. A. Dixon. 2002b. Evaluation of Angled Bar Racks and Louvers for Guiding Lake and Shortnose Sturgeon. Pages 197-210 *in* W. Van Winkle, P. J. Anders, D. H. Secor, and D. A. Dixon, editors. Biology, Management, and Protection of North American Sturgeon. American Fisheries Society, Symposium 28, Bethesda, Maryland.
- Amaral, S. V., F. C. Winchell, B. J. McMahon, and D. A. Dixon. 2003. Pages 367-376 *in* D. A. Dixon, editor. Biology, Management, and Protection of Catadromous Eels. American Fisheries Society, Symposium 33, Bethesda, Maryland.
- Ameren. 2011. Osage fish protection plan: annual report #2, Osage Project FERC No. 459. 20110329 FERC.
- Anderson, J. J., K. J. Puckett, and R. S. Nemeth. 1988. Studies on the Effect of Behavior on Fish Guidance Efficiency at Rocky Reach Dam: Avoidance to Strobe Light and Other Stimuli. University of Washington, Fisheries Research Institute.FRI-UW-8801.
- Applied Science Associates (ASA). 1999. Ichthyoplankton Monitoring Study Deployment of a Gunderboom System at Lovett Generating Station Unit 3 1998. Orange and Rockland Utilities, Inc.
- Applied Science Associates (ASA). 2001. Ichthyoplankton Monitoring Study. Deployment of the Gunderboom MLES™ at Lovett Generating Station Unit 3 2000. Final Report. Prepared for Mirant, New York (In LMS 2001).
- Applied Science Associates (ASA). 2004. Gunderboom MLES™ Evaluation Study at the Lovett Generating Station. Results of 2004 Biological Monitoring. Final Report. Prepared for Mirant Lovett, LLC.
- Applied Science Associates (ASA). 2006a. Gunderboom MLES™ Evaluation Study at the Lovett Generating Station. Results of 2005 Biological Monitoring. Final. Prepared for Mirant Lovett, LLC.
- Applied Science Associates (ASA). 2006b. Gunderboom MLES™ Evaluation Study at the Lovett Generating Station. Results of 2006 Biological Monitoring. Final Report. Prepared for Mirant Lovett, LLC.
- ASA Analysis & Communication, Inc. 2008. Evaluation of impingement survival on the hydrolox traveling water screen at the E. F. Barrett Generating Station October 2007 – June 2008. Prepared for National Grid Environmental Engineering Department and Intralox.
- Applied Science Associates (ASA). 2011. Hudson generating station 316(b) study report Prepared for PSEG Fossil LLC.



Ayres Associates. 2001. Elkhead Dam/Reservoir Fish Separation Preliminary Design Report. Prepared for City of Craig. Ayres Project No. 35-0119.00.

Bailey, D. E. 2005. Effectiveness, Operation and Maintenance, and Costs of a Barrier Net System for Impingement Reduction at the Chalk Point Generating Station. In: Proceedings of Symposium on Technologies for Protecting Aquatic Organisms from Cooling Water Intake Structures. May 6 - 7, 2003, Arlington, Virginia. Sponsored by the U. S. Environmental Protection Agency.

Baker, J. K. 2008. The effects of strobe light and sound behavioral deterrent systems on impingement of aquatic organisms at Plant Barry, Alabama. A thesis submitted to the Graduate Facility of Auburn University in partial fulfillment of the requirements for the Degree of Master of Science.

Basham, L. R., M. R. Delarm, J. B. Athern, and S. W. Pettit. 1982. Fish Transportation Oversight Team Annual Report, FY 1981: Transport Operations on the Snake and Columbia Rivers. NOAA Technical Memorandum NMFS F/NNR-2. Environmental and Technical Services Division, Northwest Regional Office, National Oceanic and Atmospheric Administration, National Marine Fisheries Service, Portland, OR.

Beak Consultants, Inc. 1988. Dunkirk Station Biological Studies Final Report January - December 1987. Prepared for Niagara Mohawk Power Corporation.

Beak Consultants, Inc. 2000a. Post-Impingement Fish Survival Dunkirk Steam Station, Winter, Spring, Summer, and Fall 1998–1999. Prepared for NRG Dunkirk Power L.L.C.

Beak Consultants, Inc. 2000b. Post-Impingement Fish Survival at Huntley Steam Station, Winter and Fall 1999. Final Report. Prepared for Niagara Mohawk Power Corporation.

Bell, M. C., R. E. Nece, and R. G. Porter. 1974. A Report on the Laboratory Examination of a Permeable Dyke as a Fish Barrier. Prepared for Consumers Power Company.

Bengeyfield, W. 1992. Evaluation of a Temporary Screen to Divert Fish at Puntledge GS. Prepared by Global Fisheries Consultants, Ltd. for B.C. Hydro, Vancouver, B.C.

Bengeyfield, W. 1993. Evaluation of a Temporary Screen to Divert Fish at Puntledge GS: Year 2 (1992). Prepared by Global Fisheries Consultants, Ltd. for B.C. Hydro, Vancouver, B.C.

Bengeyfield, W. 1990. Evaluation of electrical field to divert coho salmon smolts from the penstock intake at Puntledge Generating Station. Prepared for B.C. Hydro Environmental Resources, Vancouver B.C.

Bengeyfield, W. and H. A. Smith. 1989. Evaluation of Behavioral Devices to Divert Coho Salmon Smolts from the Penstock Intake at Puntledge Generating Station. B.C. Hydro Environmental Resources.

Bernier, K. 1995. 1995 Report on the Effectiveness of the Permanent Downstream Passage System for Atlantic Salmon at Weldon Dam Mattaceunk Project FERC No. 2520.

Bestgen KR; JM Bundy; KA Zelasko. 2004. Effectiveness of high-velocity profile-bar fish screens measured by exclusion and survival of early life stages of fathead minnow. North American Journal of Fisheries Management. 24: 1228-1239.

- Bigbee, D. L., R. G. King, K. M. Dixon, D. A. Dixon, and E. S. Perry. 2010. Survival of fish impinged on a rotary disk screen. *North American Journal of Fisheries Management* 30: 1420-1433.
- Black, J.L., T.W. Hogan, G.S. Allen, E.S. Perry, and K.D. Zammit. 2008. "Laboratory Evaluation of an Aquatic Filter Barrier (AFB) for Protecting Early Life Stages of Fish," Pages 217-230 in S.V. Amaral, D. Mathur, and E.P. Taft, III, editors. *Advances in Fisheries Bioengineering*. American Fisheries Society, Symposium 61, Bethesda, MD.
- Blanton, S. L., D. A. Neitzel, and C. S. Abernethy. 1998. Washington Phase II Fish Diversion Screen Evaluations in the Yakima River Basin, 1997. U.S. Department of Energy Bonneville Power Administration Environment Fish and Wildlife.
- Bowen, M. D., S. M. Siegfried, C. Liston, L. Hess, and C. Karp. 1998. Tracy Fish Collection Facility Studies, Volume 7: Fish Collections and Secondary Louver Efficiency at the Tracy Fish Collection Facility: October 1993 to September 1995. U.S. Bureau of Reclamation.
- Breitburg, D. L. & D. A. Reiher. 1988. Finfish and bluecrab impingement and survival at H. A. Wagner Generating Station for Baltimore Gas and Electric Company final report. The Academy of Natural Sciences Benedict Estuarine Research Laboratory. Report No. 88 – 7.
- Brett, J.R. and D. McKinnon. 1953. Preliminary Experiments Using Lights and Bubbles to Deflect Migrating Young Spring Salmon. *Journal of the Fisheries Research Board of Canada* 10 (8): 548-556.
- Brown, R. E. 1997. Utilization of Strobe Lighting as a Cost Effective Deterrent for Fish Turbine Mortality. In: *Fish Passage Workshop*, Milwaukee, WI, May 6–8, 1997. Sponsored by Alden Research Laboratory, Conte Anadromous Fish Research Laboratory, Electric Power Research Institute, and Wisconsin Electric Power Company.
- Brown, R. E. 1999. The Potential of Strobe Lighting as a Cost-Effective Means for Reducing Impingement and Entrainment. *Environmental Science and Policy* 3: S405-S416.
- Brown, R. E. and K. Bernier. 1997. The Use of Aquatic Guidance Strobe Lighting System to Enhance the Safe Passage of Atlantic Salmon Smolts. In: *American Fisheries Society Annual Meeting*, Monterey, CA, August 25, 1997. Sponsored by American Fisheries Society.
- Browne, M. E. 1979. Preliminary Engineering and Environmental Evaluation of Fine-Mesh Profile Wire as Powerplant Intake Screening. Pages 17–38. In: *Passive Intake Screen Workshop*, Chicago, Illinois, December, 1979.
- Browne, M. E., L. B. Glover, D. W. Moore, and D. W. Ballengee. 1981. In-situ biological and engineering evaluation of fine-mesh profile-wire cyliders as powerplant intake screens. *Advanced Intake Technology for Power Plant Cooling Water System*. Proceeding of the Workshop on Advanced Intake Technology. April 22-24, 1981.
- Brueggemeyer, V. D., D. Cowdrick, and K. Durell. 1988. Full-Scale Operational Demonstration of Fine-Mesh Screens at Power Plant Intakes. In: *Fish Protection at Steam and Hydroelectric Power Plants*, San Francisco, California, October 28–31, 1987. Sponsored by Electric Power Research Institute (EPRI). CS/EA/AP-5663-SR.

Bureau of Reclamation. 1976. Final Environmental Statement Anadromous Fish Passage Improvements, Savage Rapids Dam. Grants Pass Diversion, Rogue River Basin Project, Oregon. Prepared by Bureau of Reclamation, Pacific Northwest Region, Boise, Idaho, Department of the Interior.

Bureau of Reclamation. 1979. Formulation Working Document, Grants Pass Diversion, Rogue River Basin Project, Oregon. Prepared by Bureau of Reclamation, Pacific Northwest Region, Salem, Oregon, Department of the Interior.

Carolina Power & Light Company. 1985a. Brunswick Steam Electric Plant 1984 Biological Monitoring Report. Biology Unit Environmental Services Section.

Carolina Power & Light Company. 1985b. Brunswick Steam Electric Plant Cape Fear Studies Interpretive Report. Biology Unit Environmental Services Section.

Cassani, J. 1998. Personal Communication between J. Cassani, Lee County Hyacinth Control District and Alden, 27 July, 1998.

Christie, A.E. 1990. A Synopsis of Ontario Hydro Advances to Protect and Guide Fish. Proceedings of the International Symposium on Fishways, Gifu, Japan, October 8–10, 1990.

Clark, D. E. 1981. The Wedge-wire Screen: A Part of the Sullivan Plant Downstream Migrant Bypass System. Manuscript. Portland General Electric Company, Portland, Oregon.

Clark, D. E. and D. P. Cramer. 1993. Evaluation of the Downstream Migrant Bypass System - T. W. Sullivan Plant, Willamette Falls. Portland General Electric, Portland, Oregon.

Consolidated Edison Company of New York, Inc. 1975. First Progress Report Indian Point Flume Study. Prepared by Stone and Webster Engineering Corporation.

Consolidated Edison Company of New York, Inc. 1994. Evaluation of Underwater Sound to Reduce Impingement at the Arthur Kill Station. Consolidated Edison Company of New York, Inc.

Consolidated Edison Company of New York, Inc. 1996. Arthur Kill Generating Station Diagnostic Study and Postimpingement Viability Substudy Report. Pursuant to December 23, 1993 Order of Consent. Report number R2-2985-90-04.

Consolidated Edison Corporation of New York, Inc. 1986. Biological Evaluation of a Ristroph Screen at Indian Point Unit 2. Consolidated Edison Corporation of New York, Inc.

Consumers Energy Company and The Detroit Edison Company. 2005. Ludington Pumped Storage Project: 2005 Annual Report of Barrier Net Operation. Project No. 2680.

Consumers Power Company (CPC). 1984. 1984 Report of Deterrent Net Performance, J. R. Whiting Plant. Presented to the Michigan Water Resources Commission, June 1984.

Consumers Power Company (CPC). 1985. 1985 Report of Deterrent Net Performance, J. R. Whiting Plant. Presented to the Michigan Water Resources Commission, June 1985.

Cord, I. and G. P. Arron. 2007. Operational fish deterrent system at Lambton November 2005-April 2007. Prepared for Ontario Power Generation, Inc.

- Coutant, C.C. 2001. Turbulent Attraction Flows for Guiding Juvenile Salmonids at Dams. Pages 57–77 in C. Coutant, editor. Behavioral Technologies for Fish Guidance. American Fisheries Society, Symposium 26, Bethesda, MD.
- Craddock, D.R. 1956. A Review of Studies in Guiding Downstream Migrating Salmon with Light. In: Progress Report on Fisheries Engineering Research Program. U.S. Army, North Pacific Division, Corps of Engineers, Portland, Oregon, p. 1-13.
- Cramer, D. P. 1997. Evaluation of a Louver Guidance System and Eicher Screen for Fish Protection at the T.W. Sullivan Plant in Oregon. In: Fish Passage Workshop, Milwaukee, WI, May 6-8, 1997. Sponsored by Alden Research Laboratory, Conte Anadromous Fish Research Laboratory, Electric Power Research Institute, and Wisconsin Electric Power Company.
- Cramer, S. P., D. Demko, and E. Van Dyke. 1993. Evaluation of the Latest Technology Electrical and Acoustic Fish Guidance Systems at Reducing Entrainment of Down Migration Juvenile Chinook Salmon at Reclamation District 108's Main Pumping Station. Prepared by S. P. Cramer & Associates. 300 S. E. Arrow Creek Land, Gresham, OR 97080.
- Cumbie P. M. and J. B. Banks. 1997. Protection of Aquatic Life in Design and Operation of the Cope Station Water Intake and Discharge Structures. The Environmental Professional 19: 178–184.
- Darland T.J., S.D. Evans, D.W. Rondorf, G.L. Rutz, D.H. Feil, N.S. Adams, C.F. Merrill, and J.D. Serl. 2001. Test of Concept to Improve Fish Guidance Using Induced Water Currents at Cowlitz Falls Dam, Washington. Annual Report for 1999. U.S. Geological Survey, Columbia River Research Laboratory, Cook, Washington.
- Davis, R. W., J. A. Matousek, M. J. Skelly, and M. R. Anderson. 1988. Biological Evaluation of Brayton Point Station Unit 4 Angled Screen Intake. In Proceedings: Fish Protection at Steam and Hydroelectric Power Plants, San Francisco, California, October 28–31, 1987. Sponsored by Electric Power Research Institute (EPRI). CS/EA/AP-5663-SR.
- Dawson, H.A., U.G. Rheinhardt, and J.F. Savino. 2006. Use of Electric or Bubble Barriers to Limit the Movement of Eurasian Ruffe (*Gymnocephalus cernuus*). J. Great Lakes Res. 32:40-49.
- Decoto, R. J. 1978. 1974 Evaluation of the Glenn-Colusa Irrigation District Fish Screen. California Department of Fish and Game, Anadromous Fisheries Branch. Administrative Report No. 78-20.
- Detroit Edison Company. 1975. Progress Report on Best Available Technology for the Monroe Power Plant. Prepared for submission to the Chief Engineer of the Michigan Water Resources Commission, February 1975.
- Dorratcague, D., W. Porter, and L. Swenson. 1996. White River Fish Screen Project-Hydraulic Modeling . In: North American Water and Environmental Congress, New York, NY, 1996. Sponsored by American Society of Civil Engineers.
- Dunning, D. 1997. Ultrasound Deterrence: Alewife at a Nuclear Generating Station in New York. In: Using Sound to Modify Fish Behavior at Power-Production and Water-Control Facilities: A Workshop, 1997. Sponsored by U.S. Department of Energy and Bonneville Power Administration, DOE/BP-62611-11.

- Dunning, D. J. and C. W. D. Gurshin. 2012. Downriver passage of juvenile blueback herring near an ultrasonic field in the Mohawk River. *North American Journal of Fisheries Management* 32 (2): 365-380.
- Dunning, D. J., Q. E. Ross, P. G. Geoghegan, J. J. Reichle, J. K. Menezes, and J. K. Watson. 1992. Alewives Avoid High-Frequency Sound. *North American Journal of Fisheries Management* 12: 407-416.
- Easterbrooks, J. 1998. Personal Communication between J. Easterbrooks, Dept. of Fish and Wildlife, WA and Alden, 09 September, 1998.
- EA Science and Technology. 1986. Results of entrainment and impingement monitoring studies at the Westchester RESCO Facility, Peekskill, New York.
- Ecological Analysts, Inc. 1977. Preliminary Investigations into the Use of a Continuously Operating Fine Mesh Traveling Screen to Reduce Ichthyoplankton Entrainment at Indian Point Generating Station. Consolidated Edison Company of New York, Inc.
- Ecological Analysts, Inc. 1979. Evaluation of the Effectiveness of a Continuously Operating Fine Mesh Traveling Screen for Reducing Ichthyoplankton Entrainment at the Indian Point Generating Station. Prepared for Consolidated Edison Company of New York, Inc.
- Ecological Analysts, Inc. 1982. A Biological Evaluation of Modified Vertical Traveling Screens. Central Hudson Gas and Electric Corporation.
- EA Engineering, Science, and Technology, Inc. 2011. Geiger screen impingement monitoring at the Fort Calhoun Station. Prepared for Omaha Public Power District.
- Ehrler, C. and C. Raifsnider. 2000. Evaluation of the Effectiveness of Intake Wedge Wire Screens. *Environmental Science and Policy* 3
- Eisele, P. J. and J. F. Malaric. 1977. A Conceptual Model of Causal Factors Regarding Gizzard Shad Runs at Steam Electric Power Plants. In: Fourth National Workshop on Entrainment and Impingement, Chicago, IL, December 5, 1977. Sponsored by Ecological Analysts, Inc.
- Electric Power Research Institute (EPRI). 1986a. Assessment of Downstream Migrant Fish Protection Technologies for Hydroelectric Application. EPRI AP-4711
- Electric Power Research Institute (EPRI). 1986b. Research Coordination for Field Testing of Cooling Water Intake Systems - Annual Report. EPRI RP2214-4 1985.
- Electric Power Research Institute (EPRI). 1987. Hydraulic Model Evaluation of the Eicher Passive Pressure Screen Bypass System. RP-1745-18.
- Electric Power Research Institute (EPRI). 1989. Field Testing of Behavioral Barriers for Fish Exclusion at Cooling-Water Intake Systems, Ontario Hydro Pickering Nuclear Generating Station. EPRI, Palo Alto, CA. GS-6246.
- Electric Power Research Institute (EPRI). 1990. Fish Protection Systems for Hydro Plants; Test Results. EPRI GS-6712.
- Electric Power Research Institute (EPRI). 1991. Evaluation of the Eicher Screen at Elwha Dam: Spring 1990 Test Results. GS/EN-7036.

Electric Power Research Institute (EPRI). 1992a. Evaluation of the Eicher Screen at Elwha Dam: 1990 and 1991 Test Results.

Electric Power Research Institute (EPRI). 1992b. Evaluation of Strobe Lights for Fish Diversion at the York Haven Hydroelectric Project. EPRI TR-101703.

Electric Power Research Institute (EPRI). 1994a. Research Update on Fish Protection Technologies for Water Intakes. EPRI TR-104122.

Electric Power Research Institute (EPRI). 1994b. Biological Evaluation of a Modular Inclined Screen for Protecting Fish at Water Intakes. EPRI TR-104121.

Electric Power Research Institute (EPRI). 1996. Evaluation of the Modular Inclined Screen (MIS) at the Green Island Hydroelectric Project: 1995 Test Results. EPRI. TR-106498.

Electric Power Research Institute (EPRI). 1998a. Review of Downstream Fish Passage and Protection Technology Evaluations and Effectiveness. EPRI TR-111517.

Electric Power Research Institute (EPRI). 1998b. Evaluation of Fish Behavioral Barriers. EPRI TR-109483.

Electric Power Research Institute (EPRI). 1999. Fish Protection at Cooling Water Intakes: Status Report. EPRI TR-114013.

Electric Power Research Institute (EPRI). 2000. Technical Evaluation of the Utility of Intake Approach Velocity as an Indicator of Potential Adverse Environmental Impact under Clean Water Act Section 316(b). 1000731. Prepared by Oak Ridge National Laboratory (C. Coutant, M. Bevelhimer, and G. Cada).

Electric Power Research Institute (EPRI). 2001. Evaluation of Angled Bar Racks and Louvers for Guiding Fish at Water Intakes. EPRI TR-1005193.

Electric Power Research Institute (EPRI). 2003. Laboratory Evaluation of Wedge Wire Screens for Protecting Early Life Stages of Fish at Cooling Water Intakes. EPRI 1005339.

Electric Power Research Institute (EPRI). 2004. Laboratory Evaluations of an Aquatic Filter Barrier (AFB) for Protecting Early Life Stages of Fish. EPRI, Palo Alto, CA. 1005534.

Electric Power Research Institute (EPRI). 2005. Field Evaluation of Wedgewire Screens for Protecting Early Life Stages of Fish at Cooling Water Intakes. EPRI, Palo Alto, CA: 2005. 1010112.

Electric Power Research Institute (EPRI). 2006a. Laboratory Evaluation of Modified Ristroph Traveling Screens for Protecting Fish at Cooling Water Intakes. EPRI, Palo Alto, CA: 2006. 1013238.

Electric Power Research Institute (EPRI). 2006b. Field Evaluation of Wedgewire Screens for Protecting Early Life Stages of Fish at Cooling Water Intake Structures: Chesapeake Bay Studies. EPRI, Palo Alto, CA: 2006. 1012542.

Electric Power Research Institute (EPRI). 2006c. Design Considerations and Specifications for Fish Barrier Net Deployment at Cooling Water Intake Structures. 1013309.

Electric Power Research Institute (EPRI). 2007. Latent Impingement Mortality Assessment of the Geiger Multi-disc™ Screening System at the Potomac River Generating Station. EPRI 1013065.

Electric Power Research Institute. 2008. Evaluation of Strobe Light and Acoustic Fish Deterrent System: Plant Barry: 316(b) Technology Option. EPRI, Palo Alto, CA and Alabama Power Company, Birmingham, Alabama: 2008. 1014022.

Electric Power Research Institute. 2009. Beaudrey Water Intake Protection (WIP) screen pilot-scale impingement survival study. EPRI, Palo Alto, CA and OPPD, Omaha, NE: 2009. 1018490.

Electric Power Research Institute. 2009. Laboratory Evaluation of Fine-mesh Traveling Water Screens for Protecting Early Life Stages of Fish at Cooling Water Intakes: Research Progress Update Through 2008. 1015578. EPRI, Palo Alto, CA.

Electric Power Research Institute. 2010. Laboratory Evaluation of Fine-mesh Traveling Water Screens. EPRI, Palo Alto, CA. 2010, 1019027.

Electric Power Research Institute. 2010. Evaluation of factors affecting juvenile and larval fish survival in fish return systems at cooling water intakes. EPRI, Palo Alto, CA. 2010, 1021372.

Electric Power Research Institute 2011a. Fine-mesh Traveling Screen and WIP Screen: Supplemental Laboratory Studies, EPRI, Palo Alto, CA. 2012, Technical Update 1023769.

Electric Power Research Institute. 2011b. Laboratory Evaluation of Beaudrey WIP Screen for Protecting Early Life Stages of Fish at Cooling Water Intake Structures. EPRI, Palo Alto, CA. 2011. 1019864.

Electric Power Research Institute. 2011c. Effects of fouling and debris on larval fish within a fish return system. Electric Power Research Institute. 2011, 1024999.

EPRI 2012. *Drum Screen Filtration of Cooling Water in Fossil-Fired and Nuclear Power Plants: The Electricité de France (EDF) Experience*. EPRI, Palo Alto, CA: 2012. 1026715.

Empire State Electric Energy Research Corporation (ESEERCO). 1981a. Laboratory Evaluation of Fine-Mesh Screening for the Protection of Fish Larvae at Intakes. EP 8–6. Prepared by Alden Research Laboratory and Stone & Webster Engineering Corporation.

Empire State Electric Energy Research Corporation (ESEERCO). 1981b. Laboratory Evaluation of Fish Protection Devices at Intakes. EP 8–6. Prepared by Alden Research Laboratory and Stone & Webster Engineering Corporation.

Envirex, Inc. 1996. Fish Survival Enhancement with Envirex Non-Metallic Fish Baskets and Improved Fish Spray Wash Design. Envirex, Inc., Waukesha, WI.

Environmental Consulting Services, Inc. (ECS) and Inc. Lakeside Engineering. 1994. 1993 Studies of Downstream Fish Passage at Fort Halifax Hydro-Electric Station Sebasticook River, Maine. Kennebec Hydro Developers Group.

Environmental Protection Agency (EPA). 2002. Federal Water Pollution Control Act (“Clean Water Act”), 33 U.S.C. 1251 et seq., November 27, 2002.

Environmental Protection Agency (EPA). 1972. Federal Water Pollution Control Act, §316 (b), 33 U.S.C §1326(b).

Environmental Protection Agency (EPA). 2001. 40 CFR Parts 9, 122, et al., National Pollutant Discharge Elimination System: Regulations Addressing Cooling Water Intake Structures for New Facilities; Final Rule; Federal Register, Vol. 66, No. 243, 65256, December 18, 2001.

Environmental Protection Agency (EPA). 2004. 40 CFR Parts 9, 122 et al., National Pollutant Discharge Elimination System: Final Regulations To Establish Requirements for Cooling Water Intake Structures at Phase II Existing Facilities; Final Rule; Federal Register, Vol. 69, No. 131, 41576, July 9, 2004.

Environmental Protection Agency (EPA). 2011. 40 CFR Parts 122 and 125, National Pollutant Discharge Elimination System: Cooling Water Intake Structures at Existing Facilities and Phase I Facilities; Proposed Rules; Federal Register, Vol. 76, No. 76, 22174, April 20, 2011.

Environmental Protection Agency (EPA) 2012. 40 CFR Parts 122, 123, 124, and 125, National Pollutant Discharge Elimination System—Proposed Regulations to Establish Requirements for Cooling Water Intake Structures at Existing Facilities; Notice of Data Availability Related to Impingement Mortality Control Requirements, Federal Register, Vol. 77, No. 112, 34315, June 11, 2012.

Environmental Resource Associates, Inc (ERA). 1984. Lake Erie Barrier Net, A Feasibility Study. Technical Report 61, Report to Cleveland Electrical Illuminating Company.

Federal Energy Regulatory Commission (FERC). 1997. Order Approving Downstream Fish Passage. FERC Issuance dated August 21, 1997, 80 FERC 62,166.

Feist, B.A. and J.J. Anderson. 1991. Review of Fish Behavior Relevant to Fish Guidance Systems. Fisheries Research Institute, FRI-UW-9102. University of Washington, Seattle, WA.

Federal Energy Regulatory Commission (FERC). 2001a. Order Approving Final Barrier Net Effectiveness Report. Project No. 2431-050. FERC Issuance dated February 2, 2001.

Federal Energy Regulatory Commission (FERC). 2001b. Order Approving Barrier Net Operating Protocol Pursuant to Article 405. Project No. 11402-038. FERC Issuance dated March 16, 2001, FERC 62,222.

Flamarique, I.N.N., S. Hiebert, and J. Sechrist. 2006. Visual Performance and Ocular System Structure of Kokanee and Sockeye Salmon Following Strobe Light Exposure. North American Journal of Fisheries Management 26: 453-459.

Fletcher, I. R. 1990. Flow Dynamics and Fish Recovery Experiments: Water Intake Systems. Transactions of the American Fisheries Society. 119: 393-415.

Freshwater Physicians, Inc. 1991. Belle River Power Plant Fish Entrainment and Impingement Study, 1990-1991. Detroit Edison Company.

Frizell, K. W., C. R. Liston, and S. Atkinson. 1996. Engineering Features of the Red Bluff Research Pumping Plant. In: North American Water and Environmental Congress, New York, NY, 1996. Sponsored by American Society of Civil Engineers.



- Georgia-Pacific Corporation. 1989. 1989 Report on Downstream Passage of Atlantic Salmon Smolts and Kelts at Weldon Dam. Mattaceunk Project. FERC NO. 2520.
- Georgia-Pacific Corporation. 1990. 1990 Report on Downstream Passage of Atlantic Salmon Smolts and Kelts at Weldon Dam. Mattaceunk Project. FERC NO. 2520.
- Gibson, A. J. F. and R. A. Myers. 2002. Effectiveness of a high-frequency-sound fish diversion system at the Annapolis Tidal Hydroelectric Generating Station, Nova Scotia. *North American Journal of Fisheries Management* 22: 770-784.
- Goetz, F. A., J. J. Dawson, T. Shaw, and J. Dillon. 1998. Evaluation of Low-Frequency Underwater Sound Emitters for Guiding Salmon and Steelhead Smolts away from a Navigation Lock at the Hiram Chittenden Locks, Seattle, Washington. Portland District, USACE and Lake Washington Ecological Studies Group. SBC-96-6.
- Goetz, F. A., J. J. Dawson, T. Shaw, and J. Dillon. 2001. Evaluation of low-frequency sound transducers for guiding salmon smolts away from a navigation lock. *American Fisheries Society Symposium* 26:91-104.
- Great Lakes Environmental Center (GLEC). 1994. Report on Fish Diversion at Four Mile Dam Using Strobe Lighting and Air Bubble Curtain Techniques.
- Great Northern Paper Company. 1995. The Effectiveness of Permanent Downstream Passage Facilities for Atlantic Salmon at Weldon Dam. Mattaceunk Project, FERC No. 2520.
- Great Northern Paper Company. 1998. Report on Downstream Fish Passage Studies Mattaceunk Hydroelectric Project. Great Northern Paper Company.
- Grotbeck, L.B. 1975. Evaluation of an Air Curtain as a Fish Deterrent device at Prairie Island Generating Plant Cooling Water Intake. Northern States Power (NSP), 1975 Annual Report, Environmental Monitoring and Ecological Studies Program, Prairie Island Nuclear Generating Plant, Vol II. P. 2.8-1 to 2.8-25.
- Guilfoos, E. R., R. W. Williams, T. E. Rourke, P. B. Latvaitis, J. A. Gulvas, and R. H. Reider. 1995. Six Years of Monitoring the Effectiveness of a Barrier Net at the Ludington Pumped Storage Plant on Lake Michigan. In: *Waterpower '95, Proceedings of the International Conference on Hydropower*, San Francisco, California, July 25-28, 1997. Sponsored by American Society of Civil Engineers.
- Gulvas, J. A. and I. H. Zeitoun. 1979. Cylindrical Wedge Wire Screen Investigations in Offshore Lake Michigan for the J. H. Campbell Plant, 1979. From: *Passive Intake Screen Workshop 1979*.
- Gunderboom, Incorporated. 2006. Lovett Generating Station Gunderboom® Marine Life Exclusion System™ (MLES) 2004-2005 Comprehensive Report. Prepared for Mirant. February 2006.
- Hadderingh, R. H., F. B. J. Koops and J. W. Van der Stoep. 1988. Research on fish protection at dutch thermal and hydropower stations. *Kema Scientific & Technical Reports* 6(2): 57-68.
- Hadderingh, R. H. and A. G. Smythe. 1997. Deflecting Eels from Power Stations with Light. In: *Fish Passage Workshop*, Milwaukee, WI, May 6-8, 1997. Sponsored by Alden Research

Laboratory, Conte Anadromous Fish Research Laboratory, Electric Power Research Institute, and Wisconsin Electric Power Company.

Haider, T.R. and P.H. Nelson. 1987. Protection of Juvenile Anadromous Fish. *Waterpower '87*, Proceedings of the International Conference on Hydropower.

Hamel, M. J., M. L. Brown, and S. R. Chipps. 2008. Behavioral responses of rainbow smelt to in situ strobe lights. *North American Journal of Fisheries Management* 28: 394-401.

Hanson Environmental, Inc. 1993. Demonstration Project to Evaluate the Effectiveness of an Acoustic (underwater sound) Behavioral Barrier in Guiding Juvenile Chinook Salmon at Georgiana Slough: Results of 1993 Phase I Field Tests. San Luis & Delta-Mendota Water Authority, State Water Contractors, California Department of Water Resources, and U.S. Bureau of Reclamation.

Hanson, B. N., W. H. Bason, B. E. Beitz, and K. E. Charles. 1977. A Practical Intake Screen which Substantially Reduces Entrainment and Impingement of Early Life Stages of Fish. In: Fourth National Workshop on Entrainment and Impingement, Chicago, IL, December 5, 1977. Sponsored by Ecological Analysts.

Hanson, B. N., W. H. Bason, B. E. Beitz, and K. E. Charles. 1978. Practicality of Profile-Wire Screen in Reducing Entrainment and Impingement. In: Larval Exclusion Systems for Power Plant Cooling Water Intakes. Argonne National Laboratory Report. ANL/ES-66.

Hanson, C. H., D. Hayes, and K. A. F. Urquhart. 1997. Biological Evaluations of the Georgiana Slough Experimental Acoustical Fish Barrier, Phases I-IV During 1993-1996. In: Fish Passage Workshop, Milwaukee, WI, May 6-8, 1997. Sponsored by Alden Research Laboratory, Conte Anadromous Fish Research Laboratory, Electric Power Research Institute, and Wisconsin Electric Power Company.

Harza Engineering Company and Inc. RMC Environmental Services. 1992. Response of Atlantic Salmon Smolts to Louvers in the Holyoke Canal, Spring 1992. New England Power Company.

Harza Engineering Company and Inc. RMC Environmental Services. 1993. Response of Juvenile Clupeids to Louvers in the Holyoke Canal, Fall 1992. New England Power Company.

Hawkins, A. D. and D. F. Johnstone. 1978. The Hearing of the Atlantic Salmon, *Salmo salar*. *Journal of Fish Biology*. 13: 655-673.

Heimbuch, D. E. 1999. Biological Efficacy of Intake Structure Modifications. PSE&G Renewal Application Salem Generating Station. Permit No. NJ0005622.

Helfrich, L.A., C.R. Liston, B. Mefford, and R. Bark. 2001. Survival and Injury of Splittail and Chinook Salmon Passed Through a Large Hydrostatic Pump. *North American Journal of Fisheries Management*. 21:616-623.

Henderson, P.A., R.M. Seaby, C. Cailes, and J.R. Somes. 2001. Gunderboom Fouling Studies in Bowline Pond. Prepared by Pisces Conservation, Ltd.

Holand, B. and O. Walso. 1988. Sound Barrier: Experiments with Cod at Sommaroyhamn. SINTEF Rapport for Myre Havbruk.

- Horwitz, R. J. 1987. Impingement Studies. In: *Ecological Studies in the Middle Reach of the Chesapeake Bay*, Heck, Kenneth L. Jr., ed. Springer-Verlag, New York. 1987.
- Hutchinson Jr. J.B., Matousek, J.A. 1988. Evaluation of a Barrier Net used to Mitigate Fish Impingement at a Hudson Power Plant Intake. *American Fisheries Society Monograph*. p. 4:280-285.
- Ichthyological Associates. 1994. An Evaluation of the Effectiveness of the Strobe Light Deterrent System at Milliken Station Cayuga Lake, Tomkins County, New York. New York State Electric and Gas Corporation.
- Ichthyological Associates. 1997. An Evaluation of Fish Entrainment and Effectiveness of the Strobe Light Deterrent System at Milliken Station Cayuga Lake, Tomkins County, New York. New York State Electric and Gas Corporation.
- Jahn, A.E. and K.T. Herbinson. 2000. Designing a Light-Mediated Behavioral Barrier to Fish Impingement and a Monitoring Program to Test its Effectiveness at a Coastal Power Station. *Environmental Science and Policy* 3.
- Jarrett, D. P. and F. C. Winchell. 1989. Hydraulic Evaluation of Traveling Belt Screens at Weeks Falls. Presented at the 9th Annual meeting of the Northwest Hydroelectric Association, Portland Oregon, October 1989.
- Jasperson, S. 2005 and 2006. Personal email between S. Jasperson Minnesota Power and Light and N. Olken, Alden Research Lab, Inc.
- Johnson, C. and R. Ettema. 1988. Passive Intake System for Shallow Sand-Bed River. *Journal of Hydraulic Engineering* 114: 662–674.
- Johnson, P.L. 1988. Hydraulic Design of Angled Drum Fish Screens. In: *Electric Power Research Institute, Conference on Fish Protection at Steam and Hydro Plants, San Francisco, October 28-30, 1987, EPRI CS/EA/AP-5663-SR, March 1988.*
- Johnson, P. L. and G. R. Ploskey. 1998. Behavioral Technologies for Bypass Channels, Phase 2: Evaluation of Infrasound and Strobe Lights for Redistributing Migrant Salmon Smolts in the McNary Juvenile Bypass.
- Johnson, Peter N., K. Bouchard, and F.A. Goetz. 2004. Effectiveness of Strobe Lights for Reducing Juvenile Salmonid Entrainment into a Navigation Lock. *North American Journal of Fisheries Management* 25: 491–501.
- Johnson, P. N, F. A. Goetz, and G. R. Ploskey. 2001. Evaluation of strobelsights for vertically displacing juvenile salmon near a filling culvert intake at the Hiram M. Chittenden Locks, Seattle, Washington.
- Karp, C., L. Hess, and C. Liston. 1995. Tracy Fish Collection Facility Studies, Volume 3: Re-evaluation of Louver Efficiencies for Juvenile Chinook Salmon and Striped Bass, 1993. U.S. Bureau of Reclamation.
- Kehring, K. 2006. Personal communication between K. Kehring, Exelon Corporation and G. Allen, Alden Research Lab, Inc. February 10, 2006.

- Ketschke, B. A. 1981. Field and Laboratory Evaluation of the Screening Ability of a Porous Dike. In: P. B. Dorn and Johnson (eds.), *Advanced Intake Technology for Power Plant Cooling Water Systems*, pg. 84-90.
- King, L. R., J. B. Jr. Hutchinson, and T. G. Huggins. 1978. Impingement Survival Studies on White Perch, Striped Bass, and Atlantic Tomcod at Three Hudson River Power Plants. In: *Fourth National Workshop on Entrainment and Impingement*, Chicago, IL, December 5, 1977. Sponsored by Ecological Analysts, Inc.
- Klinect, D. A., P. H. Loeffelman, and J. H. Van Hassel. 1992. A New Signal Development Process and Sound System for Diverting Fish from Water Intakes. In: *Proceedings of the American Power Conference*, Chicago, IL, April 13–15, 1992. 54: 427–432.
- Knudsen, F. R., P. S. Enger, and O. Sand. 1992. Awareness Reactions and Avoidance Responses to Sound in Juvenile Atlantic Salmon, *Salmo salar* L. *Journal of Fish Biology*. 40: 523–534.
- Knudsen, F. R., P. S. Enger, and O. Sand. 1994. Avoidance Responses to Low Frequency Sound in Downstream Migrating Atlantic Salmon Smolt, *Salmo salar*. *Journal of Fish Biology*. 45: 227–233.
- Knudsen, F.R., C.B. Shreck, S.M. Knapp, P.S. Enger, and O. Sand. 1997. Infrasound Produces Flight and Avoidance Responses in Pacific juvenile salmonids. *Journal of Fish Biology* 51, 824–829.
- Königson, S., A. Fjälling, and S. Lunneryd. 2002. Reactions in individual fish to strobe light. Field and aquarium experiments performed on whitefish (*Coregonus lavaretus*). *Hydrobiologia* 483: 39-44.
- Kuhl, G. H. and K. N. Mueller. 1988. Prairie Island Nuclear Generating Plant Environmental Monitoring Program 1988 Annual Report Fine Mesh Vertical Traveling Screens Impingement Survival Study. Northern States Power Company.
- Kupfer, G. A. and W. G. Gordon. 1966. An Evaluation of Air Bubble Curtain as a Barrier to Alewives. *Commercial Fisheries Review* 28(9): 1-9.
- Kynard, B. and C. Buerkett. 1997. Passage and Fish Behavior of Adult American Shad in an Experimental Louver Bypass System. *North American Journal of Fisheries Management*. 17: 734–742.
- Kynard, B. and J. O'Leary. 1990. Behavioral Guidance of Adult American Shad Using Underwater AC Electrical and Acoustic Fields. In: *Proceedings of the International Symposium on Fishways '90*, Gifu, Japan, October 8–10, 1990.
- Kynard, B. and J. O'Leary. 1993. Evaluation of a Bypass System for Spent American Shad at Holyoke Dam, Massachusetts. *North American Journal of Fisheries Management*. 13: 782–789.
- Kynard, B. and M. Horgan. 2001. Guidance of yearling shortnose sturgeon and pallid sturgeon using vertical bar rack and louver arrays. *North American Journal of Fisheries Management* 21:561-570.
- Lakeside Engineering, Inc. 1996. Summary Report for Rolfe Canal Project. Essex Hydro.

Larinier, M. and S. Boyer-Bernard. 1992. La Devalaison des Smolts de Salmon Atlantique au Barrage De Poutes sur L'allier (43): Utilisation de Lampes a Vapor De Mercure en vue D'optimiser L'Efficacite de L'exutoire de Devalaison. Bull. Fr. Peche Piscic. 323: 129-148.

Latvaitis, R. W., H. F. Bernhard, and D. B. McDonald. 1976. Impingement Studies at Quad-Cities Station, Mississippi River. In: Jensen, L. D. (Ed.) Proceedings of the Third National Workshop on Entrainment and Impingement, New York, NY, February 24, 1976.

Lawler, Matusky & Skelly Engineers (LMS). 1978. 1977 Hudson River Aquatic Ecology Studies at The Bowline Point Generating Station. Prepared for Orange and Rockland Utilities, Inc., Pearl River, New York.

Lawler, Matusky & Skelly Engineers LLP (LMS). 1981. Southern California Edison Company Larval Exclusion Study, Final Report February 1981. Prepared for Southern California Edison Company.

Lawler, Matusky & Skelly Engineers LLP (LMS). 1984. Evaluation of the Angled Screen Fish Diversion System at Oswego Steam Station Unit 6: Research Project No. EC104 April 1981-March 1983. Prepared for Niagara Mohawk Power Corporation

Lawler, Matusky & Skelly Engineers LLP (LMS). 1985. Fish Protective Intake Test Facility: Angled Screen Diversion Study. Prepared for Empire State Electric Energy Research Corporation (ESEERCO).

Lawler, Matusky & Skelly Engineers LLP (LMS). 1987. Brayton Point Station Unit No. 4 Angled Screen Intake Biological Evaluation Program. Prepared for New England Power Company, October 1987.

Lawler, Matusky & Skelly Engineers LLP (LMS). 1989. Exposure of Emigrating Juvenile Shad (*Alosa Sapidissima*) to Turbine Passage at the Hadley Falls Project, 1988, Holyoke, Massachusetts. Northeast Utilities Service Company and Holyoke Water Power Company.

Lawler, Matusky & Skelly Engineers LLP (LMS). 1991. Intake Debris Screen Postimpingement Survival Evaluation Study Roseton Generating Station 1990. Central Hudson Gas & Electric Corporation.

Lawler, Matusky & Skelly Engineers LLP (LMS). 1992. Intake Technology Review Oswego Steam Station Units 1--6. Niagara Mohawk Power Corporation. 191-115.

Lawler, Matusky & Skelly Engineers LLP (LMS). 1994. Effectiveness Evaluation of a Fine Mesh Barrier Net Located at the Cooling Water Intake of the Bowline Point Generating Station. Orange and Rockland Utilities, Inc.

Lawler, Matusky & Skelly Engineers LLP (LMS). 1996a. Effectiveness Evaluation of a Fine Mesh Barrier Net Located at the Cooling Water Intake of the Bowline Point Generating Station 1994 Barrier Net Evaluation Program Report. Orange and Rockland Utilities, Inc.

Lawler, Matusky & Skelly Engineers LLP (LMS). 1996b. Lovett Generating Station Gunderboom Evaluation Program 1995. Prepared for Orange and Rockland Utilities, Inc.

Lawler, Matusky & Skelly Engineers LLP (LMS). 1997. Lovett Generating Station Gunderboom Evaluation Program 1996. Prepared for Orange and Rockland Utilities, Inc.

Lawler, Matusky & Skelly Engineers LLP (LMS). 1998a. Lovett Generating Station Gunderboom System Evaluation Program 1997. Prepared for Orange and Rockland Utilities, Inc.

Lawler, Matusky & Skelly Engineers LLP (LMS). 1998b. Lovett Generating Station Gunderboom System Evaluation Program 1998. Prepared for Orange and Rockland Utilities, Inc.

Lawler, Matusky & Skelly Engineers LLP (LMS). 2001. Lovett Generating Station Gunderboom Deployment Program 2000. Prepared for Mirant, New York, Inc.

Lee, D. 2011. A Porous Dike Structure for Reducing Fish Impingement at a Power Plant. Presented at the 141st Annual Meeting of the American Fisheries Society, Washington State Convention Center, Seattle, WA, September 4-8, 2011.

Lew, A. 2012. Pickering Barrier Net. EPRI Debris Management Workshop, July 2012.

Lifton, W. 1979. Biological Aspects of Screen Testing on the St. Johns River, Palatka, Florida. Prepared for Passive Intake Screen Workshop, Chicago, IL, December, 1979.

Lindsay, B. P. 1991. Preliminary Dunkirk Steam Station post-impingement survival evaluation information. Letter report prepared for Niagara Mohawk Power Corporation. March 25, 1991.

Loeffelman, P. H., D. A. Klinec, and J. H. Van Hassel. 1991a. Fish Protection at Water Intakes Using a New Signal Development Process and Sound System. In: Proceedings of the International Conference on Hydropower, Denver, Colorado, July 24–26, 1991. Sponsored by American Society of Civil Engineers.

Loeffelman, P. H. and K. M. Tamms. 1991b. Environmental Aspects and Compliance Costs of Hydropower Regulation. In: Proceedings of the Specialty Conference on Energy in the 90's, Pittsburgh, Pennsylvania, March 10–13, 1991. Sponsored by American Society of Civil Engineers.

Loos, J. L. 1986a. Evaluation of Benefits to PEPCO of Improvements in the Barrier Net and Intake Screens at Chalk Point Station Between 1984 and 1985. Prepared for Environmental Affairs Group Water and Land Use Department Potomac Electric Power Company Washington, D. C.

Loos, J. L. 1986b. Evaluation of Benefits to PEPCO of Improvements in the Barrier Net and Intake Screens at Chalk Point Station Between 1984 and 1985. Prepared for Environmental Affairs Group Water and Land Use Department Potomac Electric Power Company Washington, D. C.

Loos, J.L. 1987. Chalk Point Station Intake Liability Values Computed After Deployment of a Second Barrier Net at the Mouth of the Intake Canal and After Discontinuation of Auxiliary Tempering Pump Usage. Prepared for Environmental Affairs Group Water and Land Use Department Potomac Electric Power Company Washington, D. C.

Maccina, M. J., J. W. Slipke, J. M. Grizzle. 1999. Effectiveness of three barrier types for confining grass carp in embayments of Lake Seminole, Georgia. *North American Journal of Fisheries Management* 19:968-976.

- Maes, J., A. W. H. Turnpenny, D. R. Lambert, J. R. Nedwell, A. Parmentier, and F. Ollevier. 2004. Field Evaluation of a Sound System to Reduce Estuarine Fish Intake Rates at a Power Plant Cooling Water Inlet. *Journal of Fish Biology* 64: 938-946.
- Malolie, M. O., B. Harryman, and B. Ament. 2001. Response of Free-Ranging Kokanee to Strobe Light. *American Fisheries Society Symposium* 26: 27-35.
- Maiolie, M. 2004. Personal communication between M. Maiolie, Idaho Department of Fish and Game (IDFG) and T.Hogan, Alden Research Laboratory, Inc. March 19, 2004.
- Marine Research, Inc. 1997. Post-impingement survival study Machester Street Station January 1996-February 1997. Prepared for Narragansett Electric and New England Power Company.
- Martin, P. and C. Sullivan. 1992. Guiding American Shad with Strobe Lights. *Hydro Review* (July Issue).
- Martin, P., J. Downing, E. P. Taft, and C. Sullivan. 1991. A Demonstration of Strobe Lights to Repel Fish. In: *Waterpower '91 Proceedings of the International Conference on Hydropower*, Denver, Colorado, July 24–26, 1991. Sponsored by American Society of Civil Engineers. TP 91-5.
- Martin, P., E. P. Taft, and C. Sullivan. 1994. Reducing Entrainment of Juvenile American Shad Using a Strobe Light Diversion System. In: *Anadromous Alosa Symposium*, Virginia Beach, Virginia, January 14-15, 1993. Sponsored by American Fisheries Society.
- Matousek, J. A., A. W. Wells, and P. M. McGroddy. 1988a. Field Testing of Behavioral Barriers for Fish Exclusion at Cooling-Water Intake Systems Central Hudson Gas & Electric Roseton Generating Station. Electric Power Research Institute (EPRI). RP 2214-6.
- Matousek, J.A., A.W. Wells, P.M. McGroddy, M.W. Daley, and W.C. Micheletti. 1988b. Biological Evaluation of Behavioral Barrier Devices at a Power Plant Intake Located on the Hudson River. In: *Proceedings: Fish Protection at Steam and Hydroelectric Power Plants*, San Francisco, CA, October 28–30, 1987. Electric Power Research Institute (EPRI). CS/EA/AP-5663-SR.
- McCauley, D. J., L. Montuori, J. E. Navarro, and A. R. Blystra. 1996. Using Strobe Lights, Air Bubble Curtains for Cost-Effective Fish Diversion. *Hydro Review* (April 1996): 42–51.
- McGroddy, P.M., J.E. Edwards, and P. Dorn. 1981. Diversion of marine fish larvae with angled louvers and fine-mesh screens. In: *Workshop on Advanced Intake Technology*, San Diego, California, April 22-24, 1981.
- McIninch, S. P. and C. H. Hocutt. 1987. Effects of Turbidity on Estuarine Fish Response to Strobe Lights. *Journal of Applied Ichthyology* 3: 97–105.
- McKinley, R. S. and P. H. Patrick. 1988. Use of Behavioral Stimuli to Divert Sockeye Salmon Smolts at the Seton Hydro-Electric Station, British Columbia. In: *Proceedings: Fish Protection at Steam and Hydroelectric Power Plants*. Electric Power Research Institute (EPRI). CS/EA/AP-5663-SR.
- McKinley, R. S., P. H. Patrick, and Y. G. Mussalli. 1987. Influence of Three Sonic Devices on Fish Behaviour. In: *Waterpower '87, Proceedings of the International Conference on*

- Hydropower, Portland, Oregon, August 19–21, 1987. Sponsored by American Society of Civil Engineers.
- McKinley, R.S. and H. Kowalyk. 1989. Effectiveness of a Fish Protection Scheme in Repelling or Diverting Fish in the Intake-Forebay of the Annapolis Tidal Power Station. Ontario Hydro and Nova Scotia Power Corporation. Report number 89–110-P.
- McLaren, J. B. and L. R. Tuttle Jr.. 2000. Fish Survival on Fine Mesh Traveling Screens. *Environmental Science and Policy* 3: S369-S374.
- McMahon, B., N. Olken, J. L. Black and D. Bailey. 2008. Potential alternative fish protection options for the H. A. Wagner Power Plant with respect to §316(b) BPJ compliance. Prepared for Constellation Energy.
- McMillen, M. D. and C. W. Smith. 1996. Comparison of Water Backwash and Brush Cleaning Systems for Vertical Panel Fish Screens. In: North American Water and Environmental Congress, New York, NY, 1996. Sponsored by American Society of Civil Engineers.
- McMillen, M. D. and W. Porter. 1996. White River Fish Screen Project Planning and Design. In: North American Water and Environmental Congress, New York, NY, 1996. Sponsored by American Society of Civil Engineers.
- McNabb, C. D., C. R. Liston, and S. M. Borthwick. 1998. In-Plant Biological Evaluation of the Red Bluff Research Pumping Plant on the Sacramento River in Northern California: 1995 and 1996. U.S. Bureau of Reclamation Red Bluff Fish Passage Program.
- McNabb, C.D., C.R. Liston, and S.M. Borthwick. 2003. Passage of Juvenile Chinook Salmon and Other Species Through Archimedes Lifts and a Hidrostral Pump at Red Bluff, California. *Transactions of the American Fisheries Society*. 132:326–334.
- Mesa et al. 2012. Field-based evaluations of horizontal flat-plate fish screens, II: Testing of a unique off-stream channel device - the Farmers Screen. *North American Journal of Fisheries Management* 32 (3) 604-612.
- Michaud, D. T. 1981. Wisconsin Electric's Experience with Porous Dike and Leaky Dam Intake Structures on Lake Michigan. In: P. B. Dorn and J. T. Johnson (Eds.) *Proceedings of the Workshop of Advanced Intake Technology*. San Diego, CA, April 22–24, 1981.
- Michaud, D. T. 1999. Personal communication between D. Michaud, WEPCO and E. P. Taft, Alden Research Laboratory, Inc. October 14, 1999.
- Michaud, D. T. and E. P. Taft. 2000. Recent Evaluations of Physical and Behavioral Barriers for Reducing Fish Entrainment at Hydroelectric Plants in the Upper Midwest. *Environmental Science and Policy* 3.
- Miller, E. F. 2007. Post-impingement survival and inferred maximum thermal tolerances for common nearshore marine fish species of Southern California. *Southern California Academy of Sciences*. 106(3): 193-207.
- Moy, P. B., I. Polls and J. M. Dettmers. 2011. The Chicago Sanitary and Ship Canal aquatic nuisance species dispersal barrier. *American Fisheries Society Symposium* 74: 121-137.



- Mueller, R. P. and D. A. Neitzel. 1998. Preliminary Findings: Evaluation of Infrasound and Strobe Lights to Elicit Avoidance Behavior in Juvenile Salmon and Char. *Aquatic Ecology*.
- Mueller, R. P., D. A. Neitzel, and B. G. Amidan. 1999. Evaluation of Infrasound and Strobe Lights to Elicit Avoidance Behavior in Juvenile Salmon and Char. U.S. Department of Energy.
- Murray, L. S. and T. S. Jinnette. 1978. Survival of Dominant Estuarine Organism Impinged on Fine Mesh Traveling Screens at the Barney M. Davis Power Station. Central Power and Light Company.
- Mussalli, Y. G., E. P. Taft, and P. Hofmann. 1978. Engineering Implications of New Fish Screening Concepts. In: Fourth National Workshop on Entrainment and Impingement, Chicago, IL, December 5, 1977. Sponsored by Ecological Analysts, Inc.
- Nedwell, J. and A. Turnpenny. 1997. The Bioacoustic Fish Fence: Fish Guidance by Evanescent Sound.
- Neitzel, D. A., C. S. Abernethy, E. W. Lusty, and L. A. Prohammer. 1985. A Fisheries Evaluation of the Sunnyside Canal Fish Screening Facility, Spring 1985: Annual Report. U.S. Department of Energy Contract DE-AC06-76RLO 1830.
- Neitzel, D. A., C. S. Abernethy, E. W. Lusty. 1986. A Fisheries Evaluation of the Richland and Toppenish/Satus Canal Fish Screening Facilities, Spring 1986. Prepared for The Bonneville Power Administration under a Related Services Agreement with the U.S. Department of Energy.
- Neitzel, D.A., T.J. Clune, and C.S. Abernathy. 1990. Evaluation of Rotary Drum Screens Used to Project Juvenile Salmonids in the Yakima River Basin, Washington, U.S.A. Proceedings of the International Symposium on Fishways '90 in Gifu, Japan, October 8-10, 1990.
- Nemeth, R. S. and J. J. Anderson. 1992. Response of Juvenile Coho and Chinook Salmon to Strobe and Mercury Vapor Lights. *North American Journal of Fisheries Management* 12: 684–692.
- Nemeth, R. S. 1989. The Photobehavioral Responses of Juvenile Chinook and Coho Salmon to Strobe and Mercury Lights. Thesis, University of Washington.
- Nestler, J. M., G. R. Ploskey, J. Pickens, J. Menezes, and C. Schilt. 1992. Responses of Blueback Herring to High-Frequency Sound and Implications for Reducing Entrainment at Hydropower Dams. *North American Journal of Fisheries Management*. 12: 667–683.
- Nestler, J. M., G. R. Ploskey, C. Schilt, and G. Weeks. 1995a. Evaluation of an Integrated Fish-Protection System. In: Proceedings of the International Conference on Hydropower, New York, NY, 1995. Sponsored by American Society of Civil Engineers.
- Nestler, J. M., G. R. Ploskey, L. T. Schneider, and G. Weeks. 1995b. Development of an Operational, Full-Scale Fish Protection System at a Major Pumped-Storage Hydropower Dam. In: Proceedings of the International Conference on Hydropower, New York, NY, 1995. Sponsored by American Society of Civil Engineers.
- Nestler, J. M., G. R. Ploskey, L. T. Schneider, and G. Weeks. 1998. Fish Protection at a Major Pumped-Storage Hydropower Dam. *HydroVision* 98.

New York Power Authority, Inc. (NYPA), Normandeau Associates, and Sonalysts, Inc. 1991. Responses of White Perch, Striped Bass, Alewives, Spottail Shiners, Golden Shiners, and Atlantic Tomcod in a Cage to High and Low Frequency Underwater Sounds Generated by an Electronic Fish Startle System. Empire State Electric Energy Research Corporation.

New York State Electric and Gas Corporation (NYSEG), Stone & Webster Engineering Corporation, and Auld Environmental Associates. 1990. Kintigh/Somerset Aquatic Monitoring Program 1989 Annual Report. New York State Electric and Gas Corporation.

Normandeau Associates, Inc. 1996a. Efficiency of the Louver System to Facilitate Passage of Emigrating Atlantic Salmon Smolts at Vernon Hydroelectric Station, Spring, 1995. New England Power Company.

Normandeau Associates, Inc. 1996b. The Vernon Bypass Fishtube: Evaluation of Survival and Injuries of Atlantic Salmon Smolts. New England Power Company.

Normandeau Associates, Inc.. 2000. Final Report Barrier Net Effectiveness Study at the Brule Hydroelectric Project, Florence County, Wisconsin. FERC Project No. 2431. Prepared for Wisconsin Electric Power Company. August 2000.

Normandeau Associates, Inc. (Normandeau). 2007. Filtrex Filter System, Taunton River Field Test Program.

Normandeau Associates, Inc. and Applied Science Associates (ASA). 2011a. 2010 IPEC wedgewire screen laboratory study. Prepared for Indian Point Energy Center.

Normandeau Associates, Inc. and Applied Science Associates (ASA). 2011b. 2011 IPEC wedgewire screen laboratory study. Prepared for Indian Point Energy Center.

Northeast Utilities Service Company (NUSCO). 1986. The Evaluation of Filtered and Unfiltered Underwater Mercury Vapor Lights to Attract Juvenile Alosids. Northeast Utilities Service Company.

Northeast Utilities Service Company. 1987. The effectiveness of the Millstone Unit 3 fish return. NPDES Permit No. CT003263.

Northeast Utilities Service Company Environmental Services (NUSCO). 1997. Downstream Passage of Atlantic Salmon (*Salmo salar*) Smolts at Cabot Station, Turners Falls, Massachusetts, 1997.

Northrup, D. & T. Inc. and Lakeside Engineering (NDT). 1995. Report of Results of the Third Year Study of the Effectiveness of Fish Passage Facilities at the Rolfe Canal Hydroelectric Project. Briar Hydro Associates.

Northrup, D. & T. Inc., Charles Ritzi Associates, Inc. Lakeside Engineering, and Aqua-Bio Tech. 1997. Evaluation of Downstream Fish Passage Facility for Juvenile Clupeids 1991 Through 1996 Final Report. Topsham Hydro Partners, Chrysler Corporation Utilco Group Inc. FERC Project No. 4784-ME.

Odeh, M. and C. Orvis. 1997. Status of Downstream Fish Passage at Hydroelectric Projects in the Northeast, USA. In: Waterpower '97, Proceedings of the International Conference on Hydropower, Atlanta, Georgia, August 5-8, 1997. Sponsored by American Society of Civil Engineers.

- Odenweller, D. B. and R. L. Brown. 1982. Delta Fish Facilities Program Report. Through June 30, 1982. Interagency Ecological Study Program for the Sacramento San Joaquin Estuary. Technical Report 6, 1982.
- Office of Technology Assessment (OTA). 1995. Fish Passage Technologies: Protection at Hydropower Facilities. U. S. Government Printing Office, Washington, D. C., September 1995. OTA-ENV-641.
- Ontario Hydro and Lawler, Matusky, & Skelly Engineers, Inc. (LMS). 1989. Field testing of behavioral barriers for fish exclusion at cooling water intake systems (Ontario Hydro Pickering Nuclear Generating Station). EPRI GS-6246.
- Oswald, R. 1999. Personal communication between R. Oswald, Wisconsin Public Service and E. P. Taft, Alden Research Laboratory, Inc., September 16, 1999.
- Ott, R. F., J. J. Strong, and H. E. Finch. 1988. Arbutle Mountain Hydro Vertical-Axis Fish Screens. Electric Power Research Institute (EPRI). CS/EA/AP-5663-SR.
- Otto, R. G., T. I. Hiebert, and V. R. Kranz. 1981. The effectiveness of a remote profile-wire screen intake module in reducing the entrainment of fish eggs and larvae. Advanced Intake Technology for Power Plant Cooling Water System. Proceeding of the Workshop on Advanced Intake Technology. April 22-24, 1981.
- Page, T. L., D. A. Neitzel, and R. H. Gray. 1977. Comparative Fish Impingement at Two Adjacent Water Intakes on the Mid-Columbia River. In: Fourth National Workshop on Entrainment and Impingement, Chicago, Illinois, December 5, 1977. Sponsored by Ecological Analysts, Inc.
- Patrick, P. H. 1982a. Effectiveness of a Hidrostral Pump and Transport System in the Live Transfer of Fish. Ontario Hydro Research Division, Report No. 82-295-K.
- Patrick, P.H. 1982b. Responses of Fish to Air Bubble Barriers. Ontario Hydro Research Division. Report number 82-362-K.
- Patrick, P.H. and B. Sim. 1985. Effectiveness of a Hidrostral pump in the live transfer of American eels. *Hydrobiologia* 128:57–60.
- Patrick, P. H. and R. S. McKinley. 1987. Field Evaluation of a Hidrostral Pump for Live Transfer of American Eels at a Hydroelectric Facility. *North American Journal of Fisheries Management*. Vol 7.
- Patrick, P. H., R. W. Sheehan, and B. Sim. 1982. Effectiveness of a Strobe Light Eel Exclusion Scheme. *Hydrobiologica*. 94: 269–277.
- Patrick, P.H., A.E. Christie, D. Sager, C. Hocutt, and J. Stauffer Jr. 1985. Responses of Fish to a Strobe Light/Air- Bubble Barrier. *Fisheries Research* 3: 157–172.
- Patrick, P. H., R. S. McKinley, and W. C. Micheletti. 1988a. Field Testing of Behavioral Barriers for Cooling Water Intake Structures — Test Site I — Pickering Nuclear Generating Station — 1985/86. Electric Power Research Institute (EPRI). CS/EA/AP-5663-SR.
- Patrick, P. H., R. S. McKinley, A. E. Christie, and J. G. Holsapple. 1988b. Fish Protection: Sonic Deterrents. In: Conference on Fish Protection at Steam and Hydro Plants, San Francisco,

CA, October 28–30, 1987. Sponsored by Electric Power Research Institute. EPRI. CS/EA/AP-5663-SR.

Patrick, P.H., J.S. Poulton, and R. Brown. 2001. Responses of American Eels to Strobe Light and Sound (Preliminary Data) and Introduction to Sound Conditioning as a Potential Fish Passage Technology. Pages 1–11 in C. Coutant, editor. Behavioral Technologies for Fish Guidance. American Fisheries Society Symposium 26, Bethesda, MD.

Patrick, P., S. Filipovic, I. Cord, R. Tsang, J. Jones. 2005. Fish Protection at Lambton November 2004-April 2005. Kinectrics Report K-010438-001-RA-0001-R00 (2005) or more recent biological data, if they are available.

Patrick, P.H., S. Filipovic, and H.J. Werksma. 2006a. Modified Porous Dike for Fish Exclusion. Hydrovision Paper and Presentation, August, 2006.

Patrick, P.H., S. Filipovic, I. Cord, and C. Tasker-Shaw. 2006b. A Hybrid Acoustic/Strobe System for Fish Exclusion. Hydrovision Paper and Presentation, August, 2006.

Pearce and Lee. 1991. Some Design Considerations for Approach Velocities at Juvenile Salmonid Screening Facilities. In: Fisheries Bioengineering Symposium. American Fisheries Society Symposium 10. J. Colt and R. J. White (eds.). Bethesda, MD.

Pickens, J. L. 1992. Instrumentation Services Division Effort to Develop Fish Barrier at Richard B. Russell Dam, Georgia. U.S. Army Engineer District, Savannah, Georgia.

Plante, T., Feldhausen, M., Olsen, D. and Michaud, D. 1997. Maintenance Requirements of a Fish Barrier Net System. In: Fish Passage Workshop, Milwaukee, WI, May 6-8, 1997. Sponsored by Alden Research Laboratory Inc., Conte Anadromous Fish Research Laboratory, Electric Power Research Institute, and Wisconsin Electric Power Company.

Ploskey, G. R. and P. N. Johnson. 1998. Effectiveness of Strobe Lights for Eliciting Vertical Avoidance by Juvenile Salmon. Proceedings of Hydrovision 1998.

Ploskey, G. R. and P. N. Johnson. 2001. Effectiveness of Strobe Light and an Infrasound Device for Eliciting Avoidance by Juvenile Salmon. American Fisheries Society Symposium 26: 37-56.

Ploskey, G. R., J. M. Nestler, G. Weeks, and C. Schilt. 1995. Evaluation of an Integrated Fish-Protection System. Waterpower '95, Proceedings of the International Conference on Hydropower.

Ploskey, G. R., P. N. Johnson, and T. J. Carlson. 1996. Evaluation of an Array of Low-Frequency, Sound Pressure Transducers for Guiding Salmon Smolts Away from Turbines at Bonneville Dam, Columbia River.

Ploskey, G. R., P. N. Johnson, M. G. Burczynski, J. M. Nestler, and T. J. Carlson. 1998a. Effectiveness of Strobe Lights, Infrasound Devices, and A Sound Transducer for Eliciting Avoidance by Juvenile Salmon. U.S. Army Engineer District, Portland Oregon.

Ploskey, G. R., P. N. Johnson, and T.J. Carlson. 1998b. Evaluation of a Low-Frequency Sound –Pressure System for Guiding Juvenile Salmon away from Turbines at Bonneville Dam, Columbia River. North American Journal of Fisheries Management 20: 951-967.

- Pock, J. D. 1988. Efficacy of Using Submerged High Intensity Mercury Vapor Lights To Improve Shad Passage at Priest Rapids Dam. Public Utility District No. 2 of Grant County.14/B9.
- Popper, A. N. 1995. Fish Sensory Responses: Prospects for Developing Behavioral Guidance Technologies. In: Fish Passage Technologies: Protection of Hydropower Facilities, Office of Technology Assessment, OTA-ENV-641 (Washington, D. C.), NTIS PB96107677.
- Popper, A. N. and T. J. Carlson. 1998. Application of Sound and Other Stimuli to Control Fish Behavior. Transactions of the American Fisheries Society. Vol. 127: 673-707.
- Public Service Enterprise Group (PSEG). 2003. Phase 1 Report Custom Requirement G.5 Multi-sensory Hybrid Intake Protection Technology Feasibility Study Section 316(b) Special Condition. Prepared by Alden Research Laboratory and Skalski Statistical Services.
- Public Service Enterprise Group (PSEG). 2004. Special Study Report, Salem Generating Station, Estimated Latent Impingement Mortality Rates: Updated Pooled Estimates Using Data From 1995, 1997, 1998, 2000, and 2003. Prepared for PSEG by Allee, King, Rosen, and Fleming, 7250 Parkway Drive, Suite 210, Hanover, MD 21076. June 18, 2004.
- Public Service Enterprise Group (PSEG). 2005. Phase 2 Report Custom Requirement G.5 Multi-sensory Hybrid Intake Protection Technology Feasibility Study Section 316(b) Special Condition. Prepared by Alden Research Laboratory and Skalski Statistical Services.
- Puckett, K. J. and J. J. Anderson. 1988. Behavioral Responses of Juvenile Salmonids to Strobe and Mercury Lights. Prepared for Stone & Webster Engineering Corporation. Report number FRI-UW-8717.
- Puget Sound Energy. 2002. Initial Consultation Document: Baker River Project, FERC No. 2150 2-6. March 2002.
- Radle, E. W. 1999. Personal communication between E. W. Radle, New York Department of Environmental Conservation and G. N. Garnett, Alden Research Laboratory, Inc. November 2, 1999.
- Radle, E. 2001. Technical memorandum: experiments with exposure of American shad eggs and larvae to the Gunderboom Marine Exclusion System. July 25:2001. New York State Department of Environmental Conservation Gunderboom File.
- Rainey, S. 1985. West Coast Fish Passage Technology Trends.
- Reider, R. H., D. D. Johnson, P. B. Latvaitis, J. A. Gulvas, and E. R. Guilfoos. 1997. Operation and Maintenance of the Ludington Pumped Storage Project Barrier Net. In: Fish Passage Workshop, Milwaukee, WI, May 6–8, 1997. Sponsored by Alden Research Laboratory, Conte Anadromous Fish Research Laboratory, Electric Power Research Institute, and Wisconsin Electric Power Company.
- Ringger, T. G. 2000. Investigations of Impingement of Aquatic Organisms at the Calvert Cliffs Nuclear Power Plant, 1975–1995. Environmental Science and Policy 3.
- Richards, N. S., S. R. Chipps, M. L. Brown. 2007. Stress response and avoidance behavior of fishes as influenced by high-frequency strobe lights. North American Journal of Fisheries Management 27: 1310-1315.

- RMC Environmental Services, Inc (RMC). and Sonalysts, Inc. 1993. Effect of Ensonification on Juvenile American Shad Movement and Behavior at Vernon Hydroelectric Station, 1992.
- Roarabaugh, D. B., J. L. Gill, and G. R. Finni. 1979. An evaluation of cylindrical wedge-wire screens at cooling water intakes in Lake Michigan: Final report. Prepared for Consumers Power Company.
- Rodgers, D. W. 1983. Methods of Attracting Fish to a Hidrostral Pump. Ontario Hydro Research Division.83-142-K.
- Ronafalvy, J. P., R. R. Cheesman, and W. M. Matejek. 2000. Circulating Water Traveling Screen Modification to Improve Impinged Fish Survival and Debris Handling at Salem Generating Station. *Environmental Science and Policy* 3: S377-S382.
- Ross, Q. E. 1999. Studies to Determine the Feasibility of Using High Frequency Sound in Conjunction with Bypasses Located outside of the Sound Field to Provide Protection for Young-of-the-Year and Adult Blueback Herring at the Crescent and Vischer Ferry Hydroelectric Projects. Prepared for New York Power Authority.
- Ross, Q. E., D. J. Dunning, R. Thorne, J. K. Menezes, G. W. Tiller, and J. K. Watson. 1993. Response of Alewives to High-Frequency Sound at a Power Intake on Lake Ontario. *North American Journal of Fisheries Management* 13: 291-303.
- Ross, Q.E., D.J. Dunning, J.K. Menezes, M.J. Kenna Jr., and G. Tiller. 1996. Reducing Impingement of Alewives with High Frequency Sound at a Power Plant on Lake Ontario. *North American Journal of Fisheries Management* 16: 548-559.
- Sager, D. R., C. H. Hocutt, and J. R. Jr. Stauffer. 2000. Avoidance Behavior of *Morone americana*, *Leiostomus xanthurus* and *Brevoortia tyrannus* to Strobe Light as a Method of Impingement Mitigation. *Environmental Science and Policy* 3.
- San Luis & Delta-Mendota Water Authority (SLDMWA) and C. H. Hanson. 1996. Georgiana Slough Acoustic Barrier Applied Research Project: Results of 1994 Phase II Field Tests. Department of Water Resources and Bureau of Reclamation.
- Sand, O., P.S. Enger, H.E. Karlson, and F.R. Knudsen; T. Kvernstuen. 2000. Avoidance Responses to Infrasonic in Downstream Migrating European Silver Eels, *Anguilla anguilla*. *Environmental Biology of Fishes*. 57: 327-336. 2000.
- Sand, O., P.S. Enger, H.E. Karlson, and F.R. Knudsen. 2001. Detection of infrasound in fish and behavioral responses to intense infrasound in juvenile salmonids and European silver eels: a minireview. Pages 183-193 in C.C. Coutant, editor. *Behavioral technologies for fish guidance*. American Fisheries Society, Symposium 26, Bethesda, MD.
- Saunders, W. P. and J. M. Mudre. 1988. An Evaluation of the Effectiveness of Fish Bypass Modifications of the Log and Ice Sluiceway at Bellows Falls Station. Prepared by International Science and Technology, Inc., for New England Power Service Company. December 1, 1988.
- Savino, J. F., D. J. Jude, and M. J. Kostich. 2001. Use of electrical barrier to deter movement of round goby. *American Fisheries Society Symposium* 26: 171-182.
- Schilt, C. and G. Ploskey. 1997. Ultrasound deterrence: blueback herring at a pumped storage facility in Georgia. In: *Using Sound to Modify Fish Behavior at Power-Production and Water-*

- Control Facilities: A Workshop, 1997. Sponsored by U.S. Department of Energy and Bonneville Power Administration, DOE/BP-62611-11.
- Schimmoller, B. K. 2005. Power-Gen International Preview: The Worm Has Turned. *Power Engineering*. October 2005. p. 62-66.
- Schuler, V. J. 1973. Experimental Studies in Guiding Marine Fishes of Southern California with Screens and Louvers. Prepared for Southern California Edison by Ichthyological Associates, Inc.
- Schuler, V. J. and L. E. Larson. 1975. Improved fish Protection at Intake Systems. *Journal of the Environmental Engineering Division: Proceedings of the American Society of Civil Engineers* 101 (EE6): 897-910.
- Scruton, D.A., R.S. McKinley, N. Kouwen, W. Eddy, and R.K. Booth. 2003. Improvement and optimization of fish guidance efficiency (FGE) at a behavioral fish protection system for downstream migrating Atlantic salmon (*Salmo salar*) smolts. *River Research and Applications*. 19:605-617.
- Simmons, M.A, C. A McKinstry, C.S. Simmons, R. LeCaire, R.L. Johnson, S.M. Angela, S.L. Thorsten, S. Francis. Strobe light deterrent efficiency test and fish behavior determination at Grand Coulee Dam third power plant forebay. Prepared for the Bonneville Power Association U.S. Department of Energy. PNNL-13777.
- Smith, K. A. 1961. Air-Curtain Fishing for Maine Sardines. *Commercial Fisheries Review*. 23:3, 1-14.
- Smith, E. J. and J. K. Anderson. 1984. Attempts to Alleviate Fish Losses from Allegheny Reservoir, Pennsylvania and New York, Using Acoustics. *North American Journal of Fisheries Management*. 4: 300-307.
- Smith, H. 1997. Operating History of the Puntledge River Eicher Screen Facility. In: *Fish Passage Workshop*, Milwaukee, WI, May 6-8, 1997. Sponsored by Alden Research Laboratory, Conte Anadromous Fish Research Laboratory, Electric Power Research Institute, and Wisconsin Electric Power Company.
- Sonny, D., F.R. Knudsen, P.S. Enger, T. Kvernstuen, and O. Sand. 2006. Reactions of Cyprinids To Infrasound in a Lake at the Cooling Water Inlet of a Nuclear Power Plant. *Journal of Fish Biology* 2006 (69): 735-748.
- Sparks, R. E., T. L. Barkley, S. M. Creque, J. M. Dettmers and K. M. Stainbrook. 2010. Evaluation of an electric fish dispersal barrier in the Chicago and Ship Canal. *American Fisheries Society Symposium* 74: 139-161.
- Springfield City, Water, Light and Power Company (SCWLP). 2004. Net Gains. SCWLP website: <http://www.cwlp.com> accessed December 2004.
- Stauffer, J. R. Jr., C. H. Hocutt, and D. R. Sager. 1983. Light as a Possible BAT for Reducing Impingement of Estuarine Fishes at Water Intake Structures of Electric Generating Facilities.
- Stewart, P.A.M. 1982. An Investigation into the Reactions of Fish to Electrified Barriers and Bubble Currents. *Fisheries Research* 1: 3-22.

Stira, R. J. and D. A. Robinson. 1997. Effectiveness of a Louver Bypass System for Downstream Passage of Atlantic Salmon Smolts and Juvenile Clupeids in the Holyoke Canal, Connecticut River, Holyoke, Massachusetts. In: Fish Passage Workshop, Milwaukee, WI, May 6-8, 1997. Sponsored by Alden Research Laboratory, Conte Anadromous Fish Research Laboratory, Electric Power Research Institute, and Wisconsin Electric Power Company.

Stober, Q. J., Tyler, R. W., Petrosky, C. E. 1983. Barrier Net to Reduce Entrainment Losses of Adult Kokanee from Banks Lake, Washington. American Fisheries Society, North American Journal of Fisheries Management, 1983, Volume 3, Number 4.

Stone & Webster Engineering Corporation (SWEC). 1976. Studies to Alleviate Fish Entrapment at Power Plant Cooling Water Intakes, Final Report. Prepared for Niagara Mohawk Power Corporation and Rochester Gas & Electric Corporation.

Stone & Webster Engineering Corporation (SWEC). 1977. Studies to Alleviate Potential Fish Entrapment Problems –Final Report, Nine Mile Point Nuclear Power Station — Unit 2 . Prepared for Niagara Mohawk Power Corporation (May 1977).

Stone & Webster Engineering Corporation (SWEC). 1979. Alternative Intake Designs for Reducing Fish Losses, Mystic Station, Unit 7. Prepared for Boston Edison Company, 1979.

Stone & Webster Engineering Corporation (SWEC). 1980. Studies to Develop an Intake Design for Reducing Entrainment Losses Unit No. 4 Big Bend Station. Prepared for Tampa Electric Company.

Stone & Webster Engineering Corporation (SWEC). 1981. Final Report Biological Evaluation of a Modified Traveling Screen Mystic Station — Unit No. 7. Prepared for Boston Edison Company.

Stone & Webster Engineering Corporation (SWEC). 1996. Evaluation of the modular inclined screen (MIS) at the Green Island Hydroelectric Project: 1996 results. Prepared for Niagara Mohawk Power Corporation and New York State Energy Research and Development Authority.

Stone & Webster Environmental Services (SWES). 1991. Evaluation of a Barrier Net for Preventing Turbine Passage at the Pine Hydroelectric Project. Prepared for Wisconsin Electric Power Company.

Stone & Webster Environmental Technology & Services (SWETS). 1994. 1993 Evaluation of Behavioral Fish Protection Technologies at the York Haven Hydroelectric Project. Prepared for Metropolitan Edison Company.

Swanson, C., P. S. Young, and J. J. Cech Jr. 1998. Swimming performance, behavior, and physiology of delta fishes in complex flows near a fish screen: biological studies using the fish treadmill. Interagency Ecological Program for the Sacramento-San Joaquin Estuary Newsletter 11:38–42.

Swink, W. D. 1999. Effectiveness of an Electrical Barrier in Blocking a Sea Lamprey Spawning Migration on the Jordan River, Michigan. North American Journal of Fisheries Management 19:397–405

Taft, E. P. and Y. G. Mussalli. 1978. Angled Screens and Louvers for Diverting Fish at Power Plants. Journal of the Hydraulics Division, May 1978. 13731: HY5.



- Taft, E. P., T. J. Horst, and J. K. Downing. 1981a. Biological Evaluation of a Fine-Mesh Traveling Screen for Protecting Organisms. In: Workshop on Advanced Intake Technology, San Diego, California, April 22–24, 1981.
- Taft, E. P., R. H. Berger, J. Larsen, J. G. Holsapple, and L. Eberley. 1981b. Laboratory Evaluation of Larval Fish Impingement and Diversion Systems. In: Proceedings of the Workshop of Advanced Intake Technology, San Diego, California, April 22–24, 1981.
- Taft, E.P. and J.S. Isakson. 1983. Study of fish protection methods related to a potential Alaskan hydropower development. Presented at the 34th AAAS Conference, Whitehorse, Yukon, Canada, Sept. 28–31, 1983.
- Taft, E.P., Y. G. Mussalli, F. ASCE, J. K. Downing, and J. O’Neil. 1986. Use of a Modified Traveling Screen for Improving Fish Survival. *Journal of Hydraulic Engineering*, 112.3: 239-242.
- Taft, E. P., F. C. Winchell, A. W. Plizga, E. M. Paolini, and C. W. Sullivan. 1995. Proceedings of the International Conference of Hydropower (Waterpower '95). American Society of Civil Engineers, J.J. Cassidy, (ed.), pp. 1742-1751.
- Taft, E. P., T. C. Cook, N. A. Brown, J. P. Ronafalvy, and M. W. Haberland. 1996. Developments in the Use of Infrasound for Protecting Fish at Water Intakes. In: North American Water and Environmental Congress, Anaheim, CA, June 22–28, 1996.
- Taft, E. P. and N. Brown. 1997. Sonic Fish Deterrence: EPRI/Alden Laboratory's Experience. In: Using sound to modify fish behavior at power-production and water-control facilities: a workshop (phase II), Portland State University, Portland, Oregon, December 12–13, 1995. Sponsored by Bonneville Power Administration, U.S. Army Corps of Engineers, and Empire State Electric Energy Research Corporation.
- Taft, E.P. 2000. Fish protection technologies: a status report. *Environmental Science & Policy*. 3: S349-359.
- Taft, E.P., D. Dixon, and C. Sullivan. 2001. Electric Power Research Institute’s (EPRI) Research on Behavioral Technologies. Pages 115–124 in C. Coutant, editor. Behavioral technologies for fish guidance. American Fisheries Society, Symposium 26, Bethesda, MD.
- Taft, E.P., F.C. Winchell, S.V. Amaral, T.C. Cook, A.W. Plizga, E.M. Paolini, and C.W. Sullivan. 1997. Field Evaluations of the New Modular Inclined Fish Diversion Screen. Pages 665 – 671 in: Waterpower '97, Proceedings of the International Conference on Hydropower, Atlanta, Georgia, August 5–8, 1997.
- Tatham, T. R., D. L. Thomas, and G. J. Miller. 1978. Survival of Fishes and Macroinvertebrates Impinged at Oyster Creek Generating Station. In: Fourth National Workshop on Entrainment and Impingement, Chicago, IL, December 5, 1977. Sponsored by Ecological Analysts, Inc.
- Taylor, R.M., M. A. Pegg, and J.H. Chick. 2005. Response of bighead carp to a bioacoustic behavioural fish guidance system. *Fisheries Management and Ecology* 12: 283-286.
- Tenera. 2007. Marin Municipal Water District Desalination Facility Intake Effects. Prepared by Tenera. Appendix C of Final Environmental Impact Report (EIR) Marin.

Tennessee Valley Authority (TVA). 1980. Evaluation of Two Concepts for Protection of Fish Larvae at Cooling Water Intakes. Prepared for U.S. Environmental Protection Agency. Report No. EPA-600/7-80-094, May 1980.

Texas Instruments Incorporated (TI). 1978. Initial and Extended Survival of Fish Collected from a Fine Mesh Continuously Operating Traveling Screen at the Indian Point Generating Station. Consolidated Edison Company of New York, Inc.

Thomas, D. L. and G. J. Miller. 1976. Impingement Studies at the Oyster Creek Generating Station, Forked River, New Jersey, from September to December 1975. Pages 317-341 in Jensen, L. D., editor. Proceedings of the Third National Workshop on Entrainment and Impingement, New York, NY, February 24, 1976.

Thompson, T. 2000. Intake Modifications to Reduce Entrainment and Impingement at Carolina Power and Light Company's Brunswick Steam Electric Plant, Southport, North Carolina. Environmental Science and Policy 3: S417-S424.

Thompson, A.M., J. Glasgow, T. Buehrens, and E.G. Drucker. 2011. Mortality in juvenile Salmonids passed through an agricultural Hidrostral pump. Fisheries Management and Ecology 18(4): 333-338.

Tomljanovich, D. A., J. H. Heuer, and C. W. Voigtlander. 1977. Investigations on the Protection of Fish Larvae at Water Intakes Using Fine-Mesh Screening. Division of Forestry, Fisheries and Wildlife Development Tennessee Valley Authority. No. B22.

Toner, T. P. 1988. Fish Diversion Studies (1987) for Black River Hydro System. Nova Scotia Power Corporation. Report No. 88-EP-5.

Truebe J.P. and E.P. Truebe. 1997. Current Inducer and Downstream Bypass System at Upper Penacook Hydroelectric Plant, July 1997. Prepared by Lakeside Engineering, Inc. Mirror Lake, New Hampshire, for Essex Hydro Associates, Boston.

Truebe J.P. and E.P. Treube. 1998. 1998 Fish Passage Report For Upper Penacook Falls. Prepared by Lakeside Engineering, Inc. Mirror Lake, New Hampshire, for Essex Hydro Associates, Boston.

Turnpenny, A. W. H. 1993. Bubble curtain fish exclusion trials at Heysham 2 Power Station February 1993. Fawley Aquatic research Laboratories, Ltd. FCR 037/93.

Turnpenny, A. W. H, and C. J. L. Taylor. 2000. A assessment of the effect of the Sizewell power stations of fish populations. Hydroecology Applications Tome 12 Vol. 1-2, 87-134.

Union Electric Company. 1982. Evaluation of the Sioux Power Plant Fish Return System. Prepared by Union Electric Company, Environmental Services Department, St. Louis, Missouri.

Vanderwalker, J.G. 1967. Response of Salmonids to Low Frequency Sound. Bureau of Commercial Fisheries Fish-Passage Research Program, Seattle, Washington.

Veneziale, E. J. 1991. Design of a Wedge Wire Screen Intake System to Replace Traveling Intake Screens at Eddystone Generating Station. In: Proceedings of American Power Conference.

- Vogel, D.A., K.R. Marine, and J.G. Smith. 1990. A summary of evaluations of upstream and downstream anadromous salmonid passage at Red Bluff Diversion Dam on the Sacramento River, California, USA. In: Proceedings of the International Symposium on Fishways, Gifu, Japan, October 8–10, 1990.
- Wahl, T.L. 2001. Hydraulic performance of Coanda-effect screens. *Journal of Hydraulic Engineering* 127(6):480-488.
- Weber, E.D., S.M. Borthwick, and L.A. Helfrich. 2002. Plasma Cortisol Stress Response of Juvenile Chinook Salmon to Passage Through Archimedes Lifts and a Hidrostal Pump. *North American Journal of Fisheries Management*. 22:563–570.
- Weisburg, S. B., W. H. Burton, F. Jacobs, and E. A. Ross. 1987. Reductions in Ichthyoplankton Entrainment with Fine-Mesh, Wedge Wire Screens. *North American Journal of Fisheries Management* 7: 386–393.
- Welton, J. S., W. R. C. Beaumont, and R. T. Clarke. 2002. The Efficacy of Air, Sound and Acoustic Bubble Screens in Deflecting Atlantic Salmon, *Salmo salar* L., Smolts in the River Frome, UK.
- Wert, M. A. 1988. Hydraulic Model Evaluation of the Eicher Passive Pressure Screen Fish Bypass System. In: Proceedings of the Electric Power Research Institute Conference on Fish Protection at Steam and Hydro Plants, San Francisco, CA., Oct. 28–30, 1987. EPRI CS/EA/AP-5663-SR.
- W.F. Baird & Associates Ltd. 2012. Bailey Generating Station: Porous Dike Cooling Water Intake Structure Fish Impingement and Entrainment Control Feasibility Study Summary. Prepared for Northern Indiana Public Services Company (NIPSCO). 101815.202.
- White, J. C. and M. C. Brehmer. 1977. Eighteen-Month Evaluation of the Ristroph Traveling Fish Screens. Virginia Electric and Power Company.
- Winchell, F. C., E. P. Taft, S. V. Amaral, L. Everhart, D. Michaud, and C. W. Sullivan. 1997. Evaluation of Behavioral Devices for Attracting/ Repelling Fishes Commonly Entrained at Mid-West Hydro Projects. In: Fish Passage Workshop, Milwaukee, WI, May 6-8, 1997. Sponsored by Alden Research Laboratory, Conte Anadromous Fish Research Laboratory, Electric Power Research Institute, and Wisconsin Electric Power Company.
- Winchell, F., N. Taft, T. Cook and C. Sullivan. 1993. Research Update on the Eicher Screen at Elwha Dam. *Waterpower '93*. p. 344-353.
- Zeitoun, I. H., J. A. Gulvas, and D. B. Roarabaugh. 1981. Effectiveness of fine mesh cylindrical wedge-wire screens in reducing entrainment of Lake Michigan ichthyoplankton. *Canadian journal of Fisheries and Aquatic Sciences* 38: 120-125.
- Zydlewski, G.B. and J.R. Johnson. 2002. Response of Bull Trout Fry to Four Types of Water Diversion Screens. *North American Journal of Fisheries Management* 22: 1276-1282.





## **Export Control Restrictions**

Access to and use of EPRI Intellectual Property is granted with the specific understanding and requirement that responsibility for ensuring full compliance with all applicable U.S. and foreign export laws and regulations is being undertaken by you and your company. This includes an obligation to ensure that any individual receiving access hereunder who is not a U.S. citizen or permanent U.S. resident is permitted access under applicable U.S. and foreign export laws and regulations. In the event you are uncertain whether you or your company may lawfully obtain access to this EPRI Intellectual Property, you acknowledge that it is your obligation to consult with your company's legal counsel to determine whether this access is lawful. Although EPRI may make available on a case-by-case basis an informal assessment of the applicable U.S. export classification for specific EPRI Intellectual Property, you and your company acknowledge that this assessment is solely for informational purposes and not for reliance purposes. You and your company acknowledge that it is still the obligation of you and your company to make your own assessment of the applicable U.S. export classification and ensure compliance accordingly. You and your company understand and acknowledge your obligations to make a prompt report to EPRI and the appropriate authorities regarding any access to or use of EPRI Intellectual Property hereunder that may be in violation of applicable U.S. or foreign export laws or regulations.

**The Electric Power Research Institute, Inc.** (EPRI, [www.epri.com](http://www.epri.com)) conducts research and development relating to the generation, delivery and use of electricity for the benefit of the public. An independent, nonprofit organization, EPRI brings together its scientists and engineers as well as experts from academia and industry to help address challenges in electricity, including reliability, efficiency, affordability, health, safety and the environment. EPRI also provides technology, policy and economic analyses to drive long-range research and development planning, and supports research in emerging technologies. EPRI's members represent approximately 90 percent of the electricity generated and delivered in the United States, and international participation extends to more than 30 countries. EPRI's principal offices and laboratories are located in Palo Alto, Calif.; Charlotte, N.C.; Knoxville, Tenn.; and Lenox, Mass.

Together...Shaping the Future of Electricity