

Prepared For:



**Post Construction Stormwater
Management Plan**

Massachusetts Army National Guard

**Automated Multipurpose
Machine Gun Range**

Camp Edwards, Massachusetts

Project No – 250194
FY 19

Prepared by

Michael Baker
INTERNATIONAL

Date: February 2020

**Massachusetts Army National Guard
Automated Multipurpose Machine Gun (MPMG) Range**

Camp Edwards, Massachusetts

Post-Construction Storm Water Management Plan

TABLE OF CONTENTS

1.0 PROJECT NARRATIVE	1
1.1 Introduction	1
2.0 SITE DESCRIPTION.....	1
2.1 Location & Characteristics	1
2.2 Existing and Proposed Conditions	3
2.3 Project Area Runoff and Site Soils.....	4
2.3 Stormwater Management Facility Design (To be provided in next submittal)	8
2.4 Nearest Receiving Water Bodies.....	10
3.0 DESIGN BASIS AND ASSUMPTIONS.....	10
4.0 INSPECTION/MAINTENANCE FREQUENCY	11
4.1 Inspection	11
4.2 Maintenance.....	11

APPENDICES

- APPENDIX A: USGS Location Map
- APPENDIX B: Aerial Map
- APPENDIX C: NRCS Soil Survey
- APPENDIX D: Post-Construction Stormwater Management Calculations
- APPENDIX E: Existing and Proposed Drainage Area Maps

LIST OF ABBREVIATIONS

NPDES	National Pollutant Discharge Elimination System
EPA	Environmental Protection Agency
FEMA	Federal Emergency Management Agency
FIRM	Flood Insurance Rate Map
NRCS	Natural Resource Conservation Service
NOAA	National Oceanic and Atmospheric Administration
USDA	United States Department of Agriculture
cfs	Cubic Feet per Second
MAARNG	Massachusetts Army National Guard
MPMG	Multipurpose Machine Gun
CP/MPFQC	Combat Pistol/Military Police Firearms Qualification Range
JMTC	Joint Military Training Center
MP	Military Police
SWM	Stormwater Management

1.0 PROJECT NARRATIVE

1.1 Introduction

The Massachusetts Army National Guard (MAARNG) Automated Multipurpose Machine Gun (MPMG) Range is located at Camp Edwards Joint Base Cape Cod (JBCC). Camp Edwards JBCC covers 22,000 acres of land and is the largest training area in the Northeast. It serves as the primary pre-mobilization training site for the Massachusetts Army National Guard and Reserve Component units in the Northeast. The Base's 15,000-acre training area hosts units from Massachusetts and throughout the region. It is located on federal land approximately 67 miles south of Boston, Massachusetts. Please refer to **Appendix A** for the USGS Location map.

The MPMG 800m Range training component provides the MAARNG and other users of Camp Edwards JBCC with the ability to qualify for use of these strategic weapons: Light Machine Gun M249 SAW, Medium Machine Gun M240B and the Automatic Rifle M249. The MPMG Range consists of eight (8) firing lanes used to train and test soldiers on the skills necessary to zero, detect, identify, engage, and defeat Stationary Infantry Targets in a tactical array.

The new range will be fully supported by the Range Operations Control Area (ROCA). The ROCA consists of a Range Tower, Operations/Storage Building, Ammunition Breakdown Building, open latrine area with portable toilet facilities, Covered Mess Shelter, Bleacher Enclosure, and General Classroom Building. New gravel paths will provide access throughout the ROCA and new utilities and grading will be necessary to accommodate the new range. The configuration of the MPMG Range and ROCA follows the guidance provided in the USACE Design Guide for the Sustainable Range Program – Multipurpose Machine Gun (MPMG) Volume, CEHNC 1110-1-23 and Training Circular 25-8. The project also includes demolition of existing on-site structures and existing range impact berms.

This Post-Construction Storm Water Management Plan is prepared to provide storm water management for the above-mentioned project as required by the State of Massachusetts and National Pollutant Discharge Elimination System (NPDES) permit.

2.0 SITE DESCRIPTION

2.1 Location & Characteristics

The site identified for the proposed MPMG Range is the existing KD Range on Forestdale-Pocasset Road, approximately 0.20 miles (1,100 feet) northwest of the intersection of Greenway Road, Mt. Bond Road and Forestdale-Pocasset Road. Access to the site will be from Forestdale-Pocasset Road.

The site is predominantly flat with slopes on the order of one (1) to two (2) percent within the existing firing line and tower area. The existing range consists of a cleared existing firing range with an approximately total area of 41.5 acres. This site also includes some down range impact berms and target emplacements as well as some minor infrastructure at the firing line. The remainder of the site consist of uncleared areas.

The proposed MPMG range is significantly larger than the existing KD range and will require significant clearing. Based on the environmental review, prepared by the MAARNG in support of the project, it does not contain any wetland areas. Please refer to **Appendix A** for the USGS location map and **Appendix B** for the project aerial map

There are two existing buildings on-site; the range tower (approximately 200 SF) which is shown in **Figure 1** below and the existing ammunition breakdown building (approximately 385 sf) which is shown in **Figure 2** below. Both buildings are wood frame construction and will be demolished in preparation for the new range.



Figure 1: Existing control tower structure



Figure 2: Existing ammunitions breakdown building

The Federal Emergency Management Agency (FEMA) has not completed a study to determine flood the hazard for the selected location; therefore, a flood map has not been published at this time. As identified within the DD1390/1391, the Project has been evaluated for flood hazards in compliance with Executive Order 11988, and the facility is not sited in an area known to be subjected to flooding.

Also identified within the DD1390/1391, the Project has been reviewed and it has determined to follow the State's Coastal Zone Plan in accordance with provisions of Section 102(2)(c) of the National Environmental Policy Act of 1969.

All information and details regarding MEPA (Massachusetts Environmental Policy Act) and NEPA (National Environmental Policy Act) for this project can be found in MPMG Environmental Assessment which is under separate cover and not included in this report.

As noted above, there are no known wetland areas within the proposed MPMG site.

2.2 Existing and Proposed Conditions

The MPMG Range and ROCA area will be accessed from Forestdale-Pocasset Road using either of the existing driveway access points. The range will be oriented on a south-north trajectory with the ROCA being located behind and to the south of the firing line. The Range Operations Tower and Bleacher Enclosure will be located immediately behind the firing line to maximize the line of sight down-range. The Operations Storage Building, Classroom Building, Covered Mess Shelter, Ammunition Breakdown Building, and the open latrine area with portable toilet facilities will be located to the south of the Range Operations Tower and Bleacher Enclosure. The Ammunitions Breakdown Building has been sited to provide a minimum standoff distance of 50 feet.

A Privately-Owned Vehicle (POV) parking area has been provided to support the site operations for 20 vehicles. A bus parking area has been provided to allow parking for three (3) trucks or busses. The POV and bus parking areas have been located east of the existing access road. An access drive to the firing positions has been provided to allow truck mounted weapons to position at each firing line.

The proposed MPMG Range provides access roads for each firing lane to service the individual target emplacements as well as new service drives to connect the new firing line and ROCA area to Forestdale-Pocasset Road. To minimize drainage impacts, the proposed sidewalks, range access roads, service drives and parking areas will be gravel. Additionally, the existing parking lot areas will be reclaimed and returned to pervious area.

The firing line and corresponding emplacements with impact berms have been graded to minimize the grading necessary for the project while ensuring that the line of site for all the targets can be achieved. This grading approach also allows the site to maintain the existing drainage and runoff patterns to the greatest extent possible with two pipe culverts added where needed to maintain the existing runoff patterns.

2.3 Project Area Runoff and Site Soils

The project is located in the Cape Cod watershed, see **Figure 3** below.

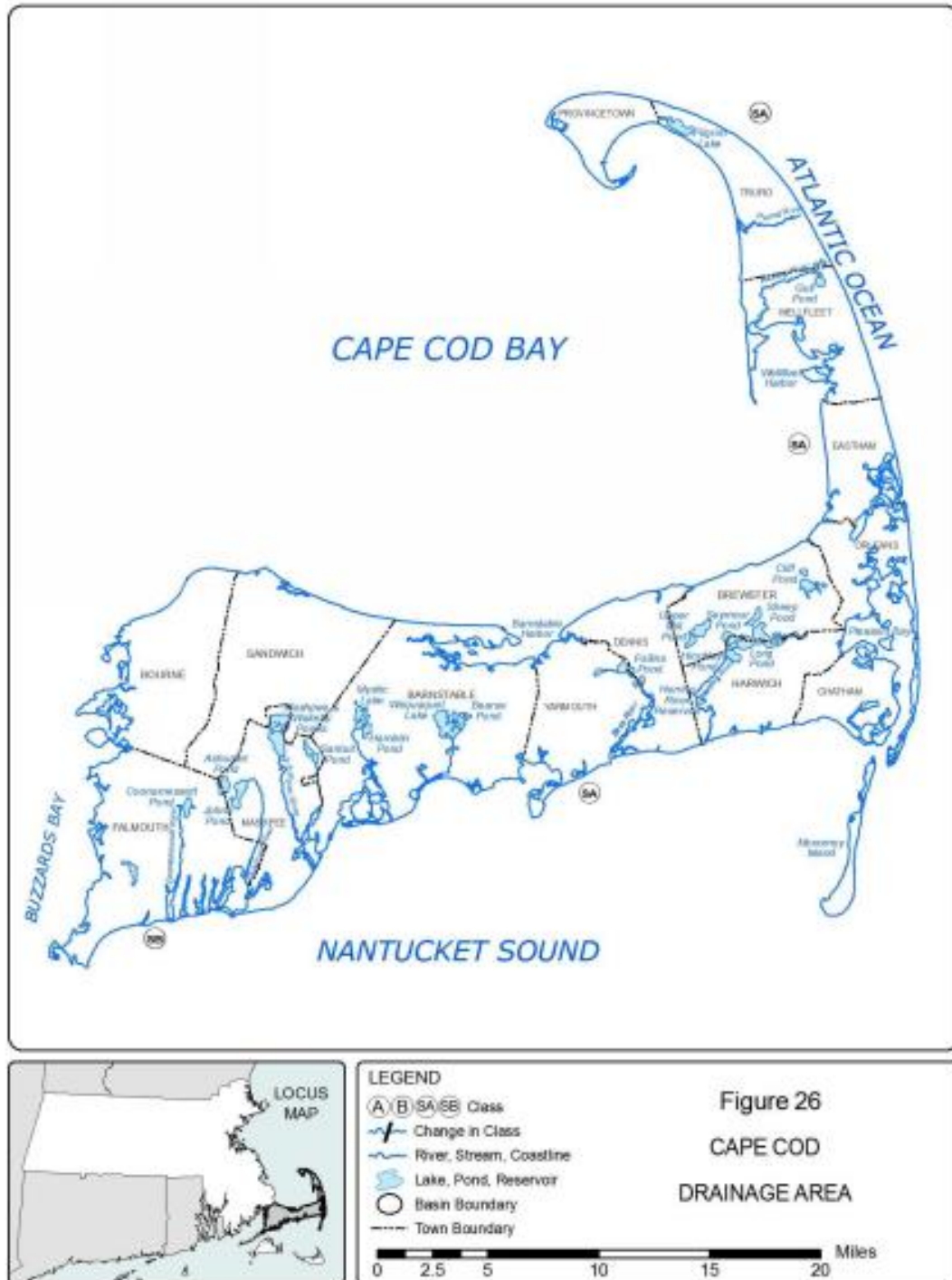

Figure 3: Cape Cod Drainage Area (Source: 314 CMR 4.00 Massachusetts Surface Water Quality Standards)

The project site is relatively flat and partially wooded.

Site soils information was obtained from the following web site: <http://websoilsurvey.nrcs.usda.gov>
See **Figure 4** and **Appendix C**. The soils located on the site are listed in Table 2.1, below.

Table 2.1 -- Hydrologic Soils Information

Soil Name	Slope	HSG Classification
254A – Merrimac fine sandy loam	0% to 3%	A
254B – Merrimac fine sandy loam	3% to 8%	A
254C – Merrimac fine sandy loam	8% to 15%	A
265A – Enfield silt loam	0% to 3%	B
435B – Plymouth loamy coarse sand	3% to 8%	A
435C – Plymouth loamy coarse sand	8% to 15%	A
435D – Plymouth loamy coarse sand	15% to 35%	A
665 – Udipsamments, smoothed	--	--

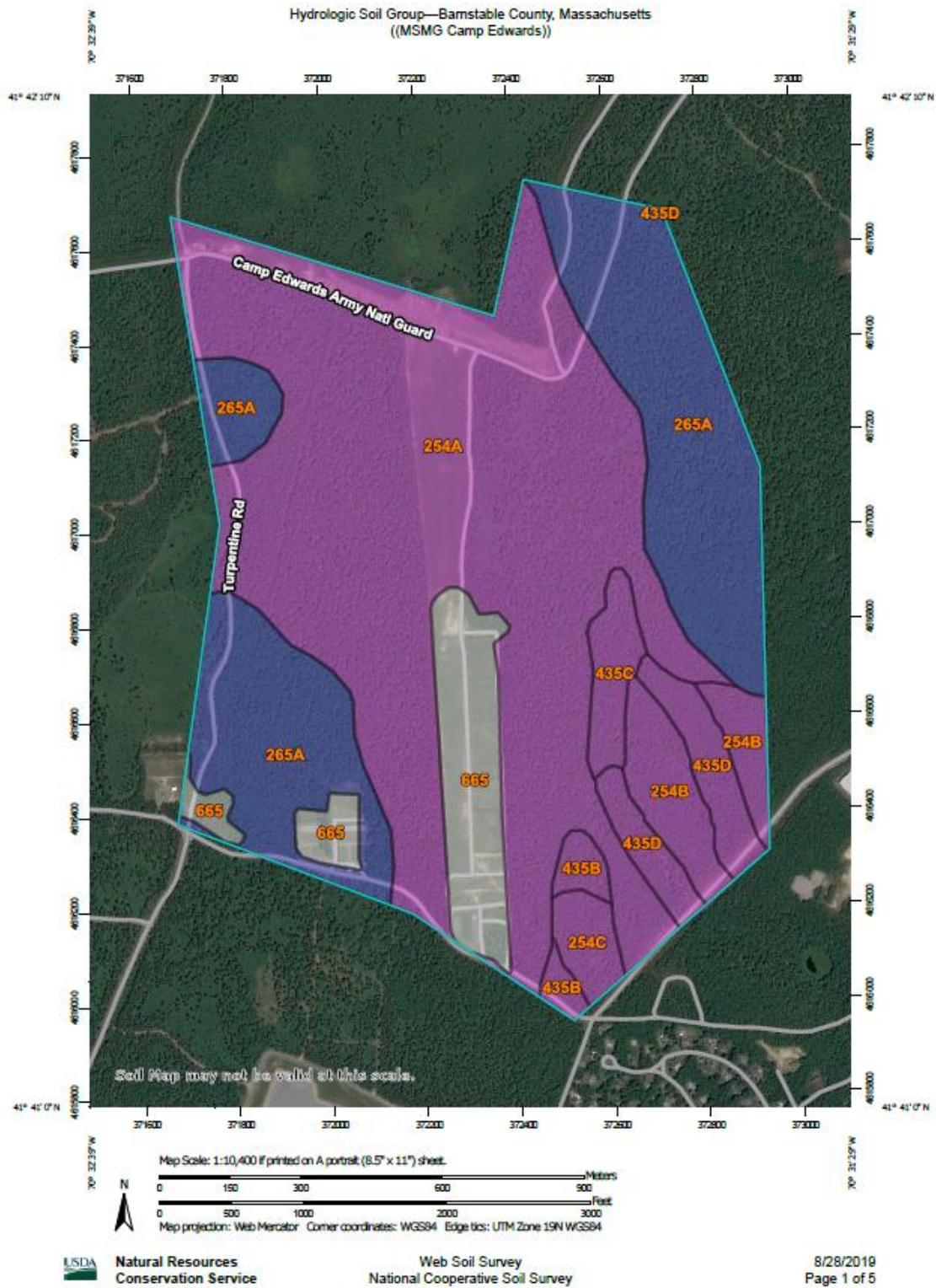

Figure 4: Camp Edwards Web Soil Survey (Source: <http://websoilsurvey.nrcs.usda.gov>)

In the area where the project will remove trees and brush to accommodate construction, the ground cover conditions will change from wooded to meadow. Two stormwater management facilities will be constructed to control runoff from this area. One extended detention basin will be constructed south of the ROCA area and handle runoff from the ROCA area. A second larger extended detention basin will be constructed east of the ROCA area and will handle runoff from the fan area. This project falls under the definition of a redevelopment project, per the Massachusetts stormwater handbook; “development rehabilitation, expansion and phased projects on previously developed sites, provided the redevelopment results in no net increase in impervious area”. The stormwater management facilities will ensure that the total rate of runoff from the post development project site will not be greater than the pre-development conditions.

Runoff calculations were performed in order to compare pre-development to post-development stormwater impacts. The methodology used for this peak discharge comparison is the United States Department of Agriculture (USDA) Natural Resources Conservation Service (NRCS) *Urban Hydrology for Small Watersheds*, Technical Release 55 (TR-55). The calculations and input parameters are found in **Appendix D** and a summary of the results are listed in the tables below.

As indicated on the Existing and Proposed Drawing Area Maps, DA-1 and DA-2, respectively (See **Appendix E**) the pre-developed site has three drainage subareas and the pre-development peak runoff rates are summarized in Table 2.2.

Table 2.2 -- Summary of Pre- Development Subarea Runoff Rates

Drainage Subarea	Time of Conc. (hrs.)	Area (acres)	Peak Runoff from Design Storm, cfs					
			2-Yr, 24-Hr.	5-Yr, 24-Hr.	10-Yr, 24-Hr.	25-Yr, 24-Hr.	50-Yr, 24-Hr.	100-Yr, 24-Hr.
A	1.52	126.44	2.72	3.42	5.70	13.38	21.75	32.99
B	1.46	126.68	2.57	3.23	3.77	4.52	5.23	8.39
C	1.27	132.29	1.95	2.49	6.16	16.21	27.03	41.38

With the construction of the MPMG range, the existing drainage areas will be altered slightly when the current range embankments are removed to accommodate the larger range fan. The embankment removal will reduce Subarea A, and slightly increase Subareas B and C.

The post-development runoff flows from the subareas are developed to the corresponding pre-development Points of Interest (POI) in the watershed. The POIs for the subareas will be the same as in the existing condition. The post-development runoff rates for Subareas A, B and C are summarized in Table 2.3 below.

Table 2.3 -- Summary of Post-Development Subarea Runoff Rates without Detention

Drainage Subarea	Time of Conc. (hrs.)	Area (acres)	Peak Runoff from Design Storm, cfs					100-Yr, 24-Hr.
A	1.51	117.03	2.62	3.35	6.37	14.97	24.05	35.94
B	1.38	133.96	1.26	1.58	1.85	2.59	5.68	11.07
C	1.26	134.46	1.67	2.14	5.99	16.04	27.00	41.52

Post development discharges for the more frequent storm events, (2, 5, 10, and 25 year) result in a net decrease in peak runoff rates overall due to the removal of the existing impervious surfaces. The post development runoff rates for the larger storm events (50 and 100) show a slight increase over the pre development rates due to the proposed clearing of woods and the addition of the gravel pathways.

The net changes in pre-development to post-development runoff rates for the drainage subareas and project area are summarized in Table 2.4.

Table 2.4 -- Summary of Net Change in Runoff Rates without Detention

Drainage Subarea	Change in Peak Runoff from Design Storm, cfs					100-Yr, 24-Hr.
A	-0.10	-0.07	0.67	1.59	2.30	2.95
B	-1.31	-1.65	-1.92	-1.93	0.45	2.68
C	-0.28	-0.35	-0.17	-0.17	-0.03	0.14
Total	-1.69	-2.07	-1.42	-0.51	2.72	5.77

The runoff from the proposed development in Subarea B will be conveyed to SWM Facilities #1 and #2 by overland flow and pipes. The stormwater management facilities will treat a drainage area of 90 acres of runoff (including meadow, gravel, and offsite impervious) to ensure flows will be released at a rate no greater than the pre-developed rate.

2.3 Nearest Receiving Water Bodies

Snake Pond is located adjacent to Camp Edwards and receives stormwater runoff from all subareas.

2.4 Stormwater Management Facility Design

Two stormwater extended detention basins are proposed to decrease the post-development peak runoff rates. One small basin will control runoff from the ROCA area and some of the fan area and is located south of the ROCA parking area. The larger basin will control runoff from most of the fan area and is located east of the ROCA, past the gravel driveway. Stormwater runoff will be conveyed over the gravel driveway crossings. Riprap will be provided at crossings to alleviate potential erosion of the access roads.

SWM Facility #1 (ROCA)

- Location: South of ROCA Area
- Top of basin elevation 156.50 ft
- Bottom of basin elevation 154.50 ft
- 18" RCP low-head pressure outlet pipe at invert elevation 154.50 ft
- Outlet control structure with:
 - 6-inch orifice at elevation 154.6 ft
 - Riser with a top elevation 156.5 ft
- Sediment forebay
- Designed freeboard of 0.65 ft for the 100-year storm event

SWM Facility #2 (FAN)

- Location: East of ROCA Area
- Top of basin elevation 157.00 ft
- Bottom of basin elevation 154.25 ft
- 18" RCP low-head pressure outlet pipe at invert elevation 154.25 ft
- Outlet control structure with:
 - 6-inch orifice at elevation 154.35 ft
 - 2-foot rectangular weir at elevation 156.00 ft
 - Riser with a top elevation 156.50 ft
- Sediment forebay
- Designed freeboard of 0.68 ft for the 100-year storm event

2.4.1. Stormwater Quantity

In accordance with Standard 2 in Massachusetts Stormwater Handbook, Volume 1, post development peak discharge rates cannot exceed pre-development post discharge rates for the 2 and 10-year 24-hour storm events. Additionally, the discharges from the 100-year 24-hour storm cannot increase off-site flooding to the maximum extent practicable. A summary of the net change in runoff peak rates with the stormwater detention basin are summarized in Table 2.6 below.

Table 2.5 -- Summary of Post-Development Subarea Runoff Rates with Detention

Drainage Subarea	Time of Conc. (hrs.)	Area (acres)	Peak Runoff from Design Storm, cfs					
			24-Hr.	24-Hr.	24-Hr.	24-Hr.	100-Yr, 24-Hr.	
A		117.03	2.62	3.35	6.37	14.96	24.05	35.94
B	1.38	133.96	0.13	0.17	0.42	1.48	2.53	4.20
C	1.26	134.46	1.67	2.14	5.99	16.04	27.00	41.52

Table 2.6 -- Summary of Net Change in Peak Runoff Rates with Detention

Drainage Subarea	Peak Runoff Reductions Summary, cfs					
	2-Yr, 24-Hr.	5-Yr, 24-Hr.	10-Yr, 24-Hr.	25-Yr, 24-Hr.	50-Yr, 24-Hr.	100-Yr, 24-Hr.
A	-0.10	-0.07	0.67	1.58	2.30	2.95
B	-2.44	-3.06	-3.35	-3.04	-2.70	-4.19
C	-0.28	-0.35	-0.17	-0.17	-0.03	0.14
Total	-2.82	-3.48	-2.85	-1.63	-0.43	-1.10

The overall peak runoff rates have been reduced in the total combined watershed for all storm events with the addition of the dry detention basins in Subarea B.

2.4.2. Stormwater Recharge

Standard 3 in Volume 1 of Massachusetts Stormwater Standards states that loss of annual recharge shall be eliminated or minimized by utilizing stormwater best management practices. There is a net decrease impervious area for all drainage subareas. Stormwater recharge is increasing from pre-construction to post-construction conditions, thus complying with Standard 3.

2.4.3. Stormwater Quality

Standard 4 in Volume 1 of Massachusetts Stormwater Standards requires 80% Total Suspended Solids (TSS) removal for the total impervious area within the post development site. The majority of the impervious areas within the project site are to be removed and replaced with gravel or reverted to pervious land. Therefore, standard 4 for is not applicable for this project.

3.0 DESIGN BASIS AND ASSUMPTIONS

In order to model the existing and proposed site conditions, as well as to estimate the approximate amount of storage that will be required by the development, the following design methods were/will be used:

- SCS and TR 55 methods, as implemented by Hydraflow Hydrographs, used for storage estimation, storm routing, and hydrograph creation.

The computer program listed above requires input data consisting of several different constants and variables. In order to obtain all the information required by the programs, certain assumptions are made concerning both existing and proposed site conditions. The IDF curves were created for the region using rainfall data obtained from The National Oceanic and Atmospheric Administration (NOAA) Atlas 14 (https://hdsc.nws.noaa.gov/hdsc/pfds/pfds_map_cont.html?bkmrk=ma). The storm event rainfall depth totals were also obtained from NOAA.

Several assumptions were incorporated in order to model the existing and proposed site conditions.

The following is a summary of the assumptions used:

- The proposed earthwork will not exceed 5' feet of cut or fill for any location within the project area, therefore the hydrologic soil groups will remain the same from pre to post development in accordance with Chapter 4.6 of the Hydrology Handbook for Conservation Commissioners.
- Wooded and meadow areas are in good condition (see Tables 2-2a and 2-2c **Appendix D**)
- Areas designated as Udipsamments, smoothed and not assigned a hydrologic soil group by the NRCS websoil survey, have been assumed to be the same hydrologic soil group as the immediate surrounding soils.

Any other assumptions used for the design of the stormwater management plan are discussed in the specific areas of the report where they apply.

4.0 INSPECTION/MAINTENANCE FREQUENCY

Stormwater treatment practices require regular maintenance to perform successfully. Failure to perform adequate maintenance can lead to reductions in pollutant removal efficiency or increase pollutant loadings and aggravate downstream impacts.

4.1 Inspection

Inspections should be performed at regular intervals to ensure proper operation of stormwater treatment practices. Inspections should be conducted at least annually, with additional inspections following large storms. Inspections should include a comprehensive visual check for evidence of the following:

- Accumulation of sediment or debris at inlet and outlet structures
- Erosion, settlement, or slope failures
- Deterioration of pipes or conduits
- Seepage at the toe of the basin

4.2 Maintenance

Any above ground detention systems need to be cleaned and maintained periodically. Inspect the extended detention basins after the first large storm to determine whether desired residence time has been achieved. Additionally, the following typical maintenance activities and frequencies are to be applied:

- Schedule semiannual inspection for the beginning and end of the wet season for standing water, slope stability, sediment accumulation, trash and debris, and presence of burrows.
- Remove accumulated trash and debris in the basin and around the outlet pipe during the semiannual inspections. The frequency of this activity may be altered to meet specific site conditions.

- Trim vegetation at the beginning and end of the wet season and inspect monthly to prevent establishment of woody vegetation and for aesthetic reasons.
- Remove accumulated sediment and regrade about every 10 years or when the accumulated sediment volume exceeds 10 percent of the basin volume. Inspect the basin each year for accumulated sediment volume.

Appendix A USGS Location Map



Produced by the United States Geological Survey
North American Datum of 1983 (NAD83)
World Geodetic System of 1984 (WGS84) Projection and
1 000-meter grid Universal Transverse Mercator, Zone 19T
This map is not a legal document. Boundaries may be
generalized for this map scale. Private lands with government
reservations may not be shown. Obtain permission before
entering private lands.

Imagery: NIP, July 2016 - September 2016
Roads: U.S. Census Bureau, 2016
Names: GNS, 1974 - 2018
Hydrography: National Hydrography Dataset, 2005 - 2015
Contours: National Elevation Dataset, 2012
Boundaries: Multiple sources; see metadata file 2016 - 2017
Wetlands: FWS National Wetlands Inventory 2008 - 2011

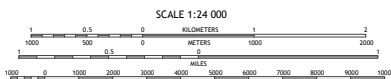
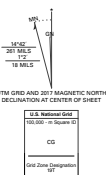

1	2	3
4	5	6
7	8	9

Adjacent Quadrangles



1 Washam
2 Segamon
3 Sandwich DE W
4 Otis
5 Sandwich
6 Woods Hole
7 Falmouth
8 Cotuit

POCASSET, MA
2018

7643016369620
NSN 7540-01-700-0000
GPO : 2018 : U.S. GOVERNMENT PRINTING OFFICE : 2018 : 7643016369620

Appendix B Aerial Map

Camp Edwards Joint Base Site Overview

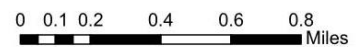
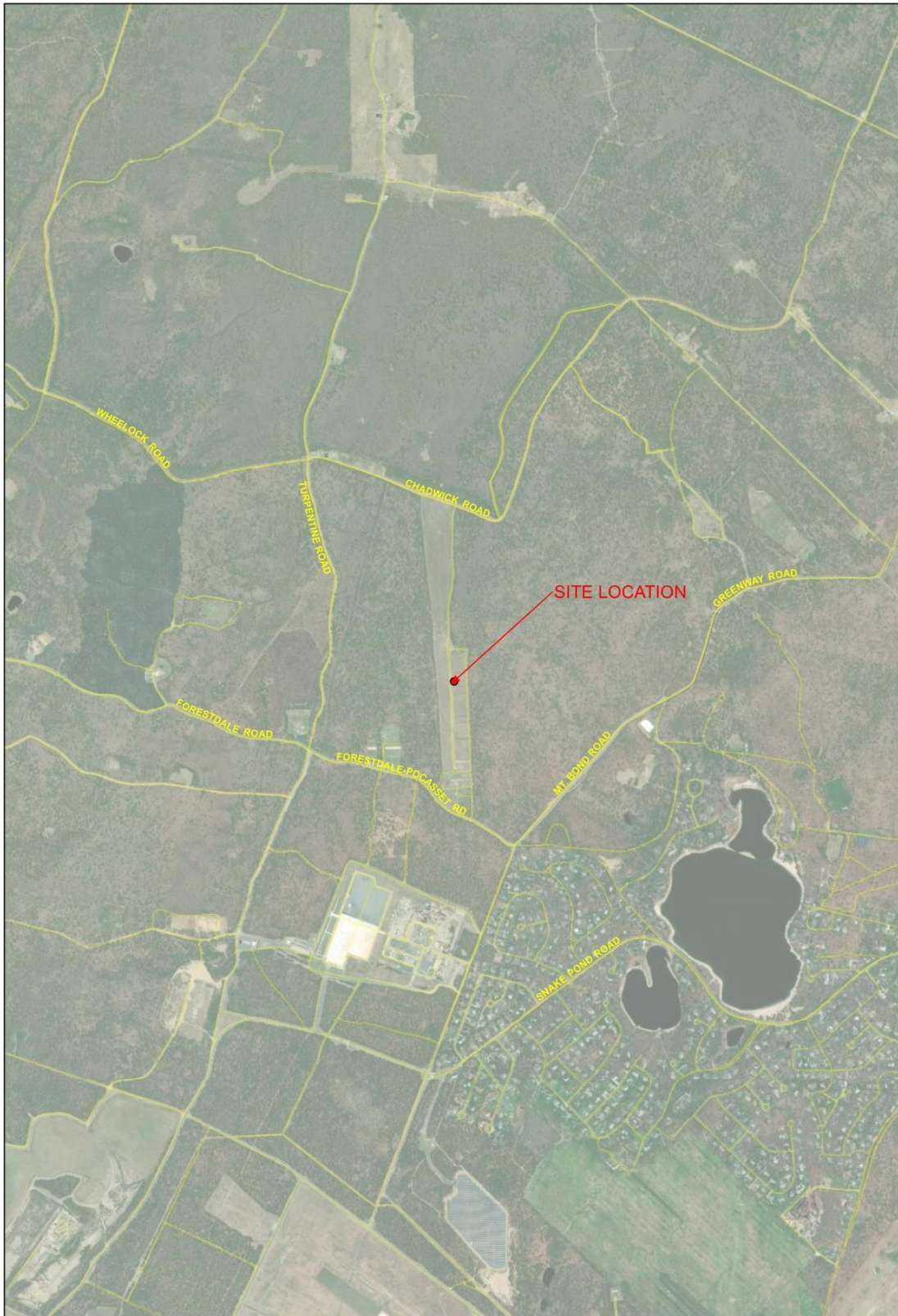

INTERNATIONAL



Appendix C NRCS Soil Report

Hydrologic Soil Group—Barnstable County, Massachusetts
((MSMG Camp Edwards))

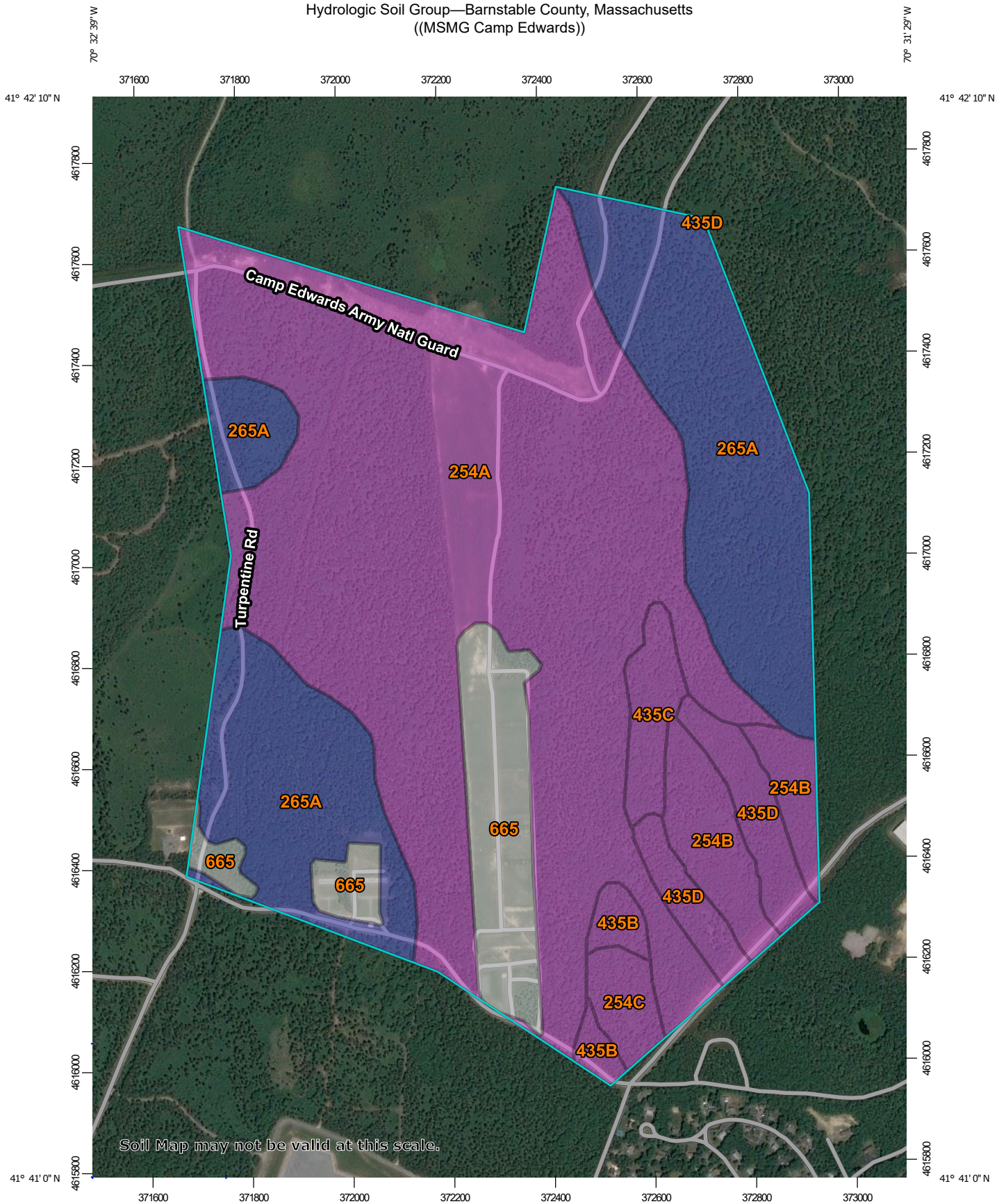

Soil Map may not be valid at this scale.

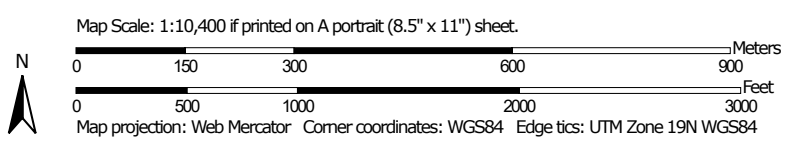

MAP LEGEND

Area of Interest (AOI)









 Area of Interest (AOI)

Soils

Soil Rating Polygons





 A
 A/D
 B
 B/D
 C
 C/D
 D
 Not rated or not available

Soil Rating Lines

 A
 A/D
 B
 B/D
 C
 C/D
 D
 Not rated or not available

Soil Rating Points





 A
 A/D
 B
 B/D

 C
 C/D
 D
 Not rated or not available

Water Features

 Streams and Canals

Transportation

 Rails
 Interstate Highways
 US Routes
 Major Roads
 Local Roads

Background

 Aerial Photography

MAP INFORMATION

The soil surveys that comprise your AOI were mapped at 1:25,000.

Warning: Soil Map may not be valid at this scale.

Enlargement of maps beyond the scale of mapping can cause misunderstanding of the detail of mapping and accuracy of soil line placement. The maps do not show the small areas of contrasting soils that could have been shown at a more detailed scale.

Please rely on the bar scale on each map sheet for map measurements.

Source of Map: Natural Resources Conservation Service
 Web Soil Survey URL:
 Coordinate System: Web Mercator (EPSG:3857)

Maps from the Web Soil Survey are based on the Web Mercator projection, which preserves direction and shape but distorts distance and area. A projection that preserves area, such as the Albers equal-area conic projection, should be used if more accurate calculations of distance or area are required.

This product is generated from the USDA-NRCS certified data as of the version date(s) listed below.

Soil Survey Area: Barnstable County, Massachusetts
 Survey Area Data: Version 15, Sep 5, 2018

Soil map units are labeled (as space allows) for map scales 1:50,000 or larger.

Date(s) aerial images were photographed: Jul 10, 2018—Nov 17, 2018

The orthophoto or other base map on which the soil lines were compiled and digitized probably differs from the background imagery displayed on these maps. As a result, some minor shifting of map unit boundaries may be evident.

Hydrologic Soil Group

Map unit symbol	Map unit name	Rating	Acres in AOI	Percent of AOI
254A	Merrimac fine sandy loam, 0 to 3 percent slopes	A	223.9	53.7%
254B	Merrimac fine sandy loam, 3 to 8 percent slopes	A	18.8	4.5%
254C	Merrimac fine sandy loam, 8 to 15 percent slopes	A	6.4	1.5%
265A	Enfield silt loam, 0 to 3 percent slopes	B	106.3	25.5%
435B	Plymouth loamy coarse sand, 3 to 8 percent slopes	A	5.3	1.3%
435C	Plymouth loamy coarse sand, 8 to 15 percent slopes	A	8.5	2.0%
435D	Plymouth loamy coarse sand, 15 to 35 percent slopes	A	16.3	3.9%
665	Udipsamments, smoothed		31.2	7.5%
Totals for Area of Interest			416.7	100.0%

Description

Hydrologic soil groups are based on estimates of runoff potential. Soils are assigned to one of four groups according to the rate of water infiltration when the soils are not protected by vegetation, are thoroughly wet, and receive precipitation from long-duration storms.

The soils in the United States are assigned to four groups (A, B, C, and D) and three dual classes (A/D, B/D, and C/D). The groups are defined as follows:

Group A. Soils having a high infiltration rate (low runoff potential) when thoroughly wet. These consist mainly of deep, well drained to excessively drained sands or gravelly sands. These soils have a high rate of water transmission.

Group B. Soils having a moderate infiltration rate when thoroughly wet. These consist chiefly of moderately deep or deep, moderately well drained or well drained soils that have moderately fine texture to moderately coarse texture. These soils have a moderate rate of water transmission.

Group C. Soils having a slow infiltration rate when thoroughly wet. These consist chiefly of soils having a layer that impedes the downward movement of water or soils of moderately fine texture or fine texture. These soils have a slow rate of water transmission.

Group D. Soils having a very slow infiltration rate (high runoff potential) when thoroughly wet. These consist chiefly of clays that have a high shrink-swell potential, soils that have a high water table, soils that have a claypan or clay layer at or near the surface, and soils that are shallow over nearly impervious material. These soils have a very slow rate of water transmission.

If a soil is assigned to a dual hydrologic group (A/D, B/D, or C/D), the first letter is for drained areas and the second is for undrained areas. Only the soils that in their natural condition are in group D are assigned to dual classes.

Rating Options

Aggregation Method: Dominant Condition

Aggregation is the process by which a set of component attribute values is reduced to a single value that represents the map unit as a whole.

A map unit is typically composed of one or more "components". A component is either some type of soil or some nonsoil entity, e.g., rock outcrop. For the attribute being aggregated, the first step of the aggregation process is to derive one attribute value for each of a map unit's components. From this set of component attributes, the next step of the aggregation process derives a single value that represents the map unit as a whole. Once a single value for each map unit is derived, a thematic map for soil map units can be rendered. Aggregation must be done because, on any soil map, map units are delineated but components are not.

For each of a map unit's components, a corresponding percent composition is recorded. A percent composition of 60 indicates that the corresponding component typically makes up approximately 60% of the map unit. Percent composition is a critical factor in some, but not all, aggregation methods.

The aggregation method "Dominant Condition" first groups like attribute values for the components in a map unit. For each group, percent composition is set to the sum of the percent composition of all components participating in that group. These groups now represent "conditions" rather than components. The attribute value associated with the group with the highest cumulative percent composition is returned. If more than one group shares the highest cumulative percent composition, the corresponding "tie-break" rule determines which value should be returned. The "tie-break" rule indicates whether the lower or higher group value should be returned in the case of a percent composition tie. The result returned by this aggregation method represents the dominant condition throughout the map unit only when no tie has occurred.

Component Percent Cutoff: None Specified

Components whose percent composition is below the cutoff value will not be considered. If no cutoff value is specified, all components in the database will be considered. The data for some contrasting soils of minor extent may not be in the database, and therefore are not considered.

Tie-break Rule: Higher

The tie-break rule indicates which value should be selected from a set of multiple candidate values, or which value should be selected in the event of a percent composition tie.

Appendix D Post-Construction Stormwater Management Calculations



NOAA Atlas 14, Volume 10, Version 3
 Location name: Sandwich, Massachusetts, USA*
 Latitude: 41.6983°, Longitude: -70.5289°
 Elevation: 168.85 ft**
 * source: ESRI Maps
 ** source: USGS



POINT PRECIPITATION FREQUENCY ESTIMATES

Sanja Perica, Sandra Pavlovic, Michael St. Laurent, Carl Trypaluk, Dale Unruh, Orlan Wilhite

NOAA, National Weather Service, Silver Spring, Maryland

[PF tabular](#) | [PF graphical](#) | [Maps & aeriels](#)

PF tabular

PDS-based point precipitation frequency estimates with 90% confidence intervals (in inches)¹										
Duration	Average recurrence interval (years)									
	1	2	5	10	25	50	100	200	500	1000
5-min	0.287 (0.235-0.350)	0.358 (0.292-0.437)	0.474 (0.388-0.580)	0.570 (0.460-0.700)	0.703 (0.549-0.897)	0.802 (0.612-1.04)	0.908 (0.673-1.22)	1.03 (0.717-1.39)	1.22 (0.812-1.69)	1.38 (0.894-1.94)
10-min	0.406 (0.332-0.498)	0.507 (0.414-0.619)	0.672 (0.546-0.822)	0.808 (0.653-0.993)	0.996 (0.778-1.27)	1.14 (0.868-1.48)	1.29 (0.954-1.73)	1.46 (1.01-1.97)	1.73 (1.15-2.39)	1.96 (1.27-2.74)
15-min	0.478 (0.391-0.583)	0.597 (0.487-0.728)	0.791 (0.644-0.968)	0.951 (0.769-1.17)	1.17 (0.915-1.50)	1.34 (1.02-1.74)	1.51 (1.12-2.03)	1.72 (1.19-2.32)	2.04 (1.35-2.81)	2.30 (1.49-3.23)
30-min	0.690 (0.564-0.842)	0.860 (0.703-1.05)	1.14 (0.925-1.39)	1.37 (1.11-1.68)	1.69 (1.32-2.15)	1.92 (1.47-2.50)	2.18 (1.62-2.92)	2.48 (1.72-3.34)	2.93 (1.95-4.05)	3.32 (2.15-4.65)
60-min	0.903 (0.738-1.10)	1.12 (0.918-1.37)	1.49 (1.21-1.82)	1.79 (1.45-2.20)	2.20 (1.72-2.81)	2.51 (1.92-3.26)	2.84 (2.11-3.81)	3.24 (2.24-4.36)	3.83 (2.55-5.30)	4.34 (2.81-6.08)
2-hr	1.24 (1.02-1.50)	1.54 (1.26-1.86)	2.03 (1.66-2.46)	2.43 (1.98-2.97)	2.99 (2.36-3.80)	3.41 (2.63-4.40)	3.86 (2.90-5.15)	4.40 (3.08-5.88)	5.23 (3.51-7.17)	5.95 (3.89-8.28)
3-hr	1.47 (1.21-1.77)	1.81 (1.50-2.19)	2.38 (1.96-2.88)	2.85 (2.33-3.46)	3.49 (2.76-4.41)	3.97 (3.08-5.11)	4.49 (3.39-5.97)	5.12 (3.60-6.80)	6.08 (4.11-8.28)	6.90 (4.55-9.54)
6-hr	1.92 (1.59-2.30)	2.33 (1.94-2.80)	3.01 (2.49-3.62)	3.58 (2.94-4.32)	4.35 (3.47-5.44)	4.93 (3.85-6.27)	5.55 (4.21-7.28)	6.29 (4.47-8.28)	7.39 (5.05-9.98)	8.33 (5.55-11.4)
12-hr	2.42 (2.03-2.88)	2.89 (2.42-3.44)	3.66 (3.05-4.37)	4.29 (3.56-5.15)	5.17 (4.14-6.40)	5.83 (4.57-7.32)	6.52 (4.97-8.42)	7.31 (5.26-9.54)	8.45 (5.84-11.3)	9.39 (6.33-12.7)
24-hr	2.91 (2.45-3.44)	3.44 (2.89-4.07)	4.30 (3.61-5.10)	5.01 (4.18-5.97)	6.00 (4.84-7.35)	6.74 (5.32-8.38)	7.51 (5.75-9.57)	8.36 (6.08-10.8)	9.55 (6.68-12.6)	10.5 (7.17-14.1)
2-day	3.36 (2.85-3.95)	3.96 (3.35-4.65)	4.93 (4.17-5.81)	5.74 (4.82-6.79)	6.86 (5.57-8.34)	7.70 (6.13-9.49)	8.57 (6.62-10.8)	9.52 (7.00-12.2)	10.9 (7.68-14.2)	11.9 (8.23-15.9)
3-day	3.68 (3.14-4.30)	4.30 (3.66-5.03)	5.31 (4.51-6.23)	6.15 (5.19-7.25)	7.31 (5.97-8.85)	8.19 (6.55-10.0)	9.10 (7.06-11.4)	10.1 (7.46-12.9)	11.5 (8.16-14.9)	12.6 (8.73-16.6)
4-day	3.96 (3.38-4.61)	4.59 (3.91-5.35)	5.62 (4.78-6.57)	6.47 (5.47-7.59)	7.65 (6.27-9.22)	8.54 (6.88-10.4)	9.46 (7.37-11.8)	10.5 (7.77-13.3)	11.8 (8.47-15.4)	12.9 (9.04-17.0)
7-day	4.67 (4.01-5.42)	5.32 (4.57-6.17)	6.38 (5.46-7.42)	7.27 (6.18-8.48)	8.48 (6.99-10.1)	9.41 (7.60-11.4)	10.3 (8.10-12.8)	11.3 (8.51-14.3)	12.7 (9.17-18.4)	13.7 (9.70-18.0)
10-day	5.33 (4.60-6.16)	6.01 (5.17-6.95)	7.11 (6.10-8.24)	8.02 (6.85-9.33)	9.28 (7.68-11.0)	10.2 (8.30-12.3)	11.2 (8.81-13.8)	12.2 (9.22-15.3)	13.5 (9.85-17.4)	14.6 (10.3-18.9)
20-day	7.32 (6.35-8.40)	8.08 (7.01-9.28)	9.34 (8.07-10.7)	10.4 (8.93-12.0)	11.8 (9.84-13.9)	12.9 (10.5-15.4)	14.0 (11.1-17.0)	15.1 (11.5-18.7)	16.4 (12.1-20.8)	17.3 (12.5-22.3)
30-day	9.00 (7.85-10.3)	9.85 (8.58-11.3)	11.2 (9.78-12.9)	12.4 (10.7-14.2)	14.0 (11.7-16.4)	15.2 (12.5-18.0)	16.4 (13.0-19.7)	17.5 (13.5-21.6)	18.9 (14.0-23.8)	19.8 (14.3-25.3)
45-day	11.1 (9.76-12.7)	12.1 (10.6-13.8)	13.7 (11.9-15.6)	14.9 (13.0-17.1)	16.7 (14.1-19.5)	18.1 (14.9-21.3)	19.5 (15.5-23.2)	20.6 (16.0-25.3)	22.0 (16.5-27.6)	22.9 (16.7-29.2)
60-day	13.0 (11.4-14.7)	14.0 (12.3-15.9)	15.7 (13.7-17.9)	17.1 (14.9-19.5)	19.1 (16.1-22.1)	20.6 (17.0-24.1)	22.0 (17.6-26.1)	23.3 (18.1-28.5)	24.7 (18.6-30.8)	25.6 (18.8-32.4)

¹ Precipitation frequency (PF) estimates in this table are based on frequency analysis of partial duration series (PDS). Numbers in parenthesis are PF estimates at lower and upper bounds of the 90% confidence interval. The probability that precipitation frequency estimates (for a given duration and average recurrence interval) will be greater than the upper bound (or less than the lower bound) is 5%. Estimates at upper bounds are not checked against probable maximum precipitation (PMP) estimates and may be higher than currently valid PMP values. Please refer to NOAA Atlas 14 document for more information.



NOAA Atlas 14, Volume 10, Version 3
 Location name: Sandwich, Massachusetts, USA*
 Latitude: 41.6977°, Longitude: -70.5304°
 Elevation: 167.81 ft**
 * source: ESRI Maps
 ** source: USGS



POINT PRECIPITATION FREQUENCY ESTIMATES

Sanja Perica, Sandra Pavlovic, Michael St. Laurent, Carl Trypaluk, Dale Unruh, Orlan Wilhite

NOAA, National Weather Service, Silver Spring, Maryland

[PF tabular](#) | [PF graphical](#) | [Maps & aerials](#)

PF tabular

PDS-based point precipitation frequency estimates with 90% confidence intervals (in inches/hour) ¹										
Duration	Average recurrence interval (years)									
	1	2	5	10	25	50	100	200	500	1000
5-min	3.44 (2.82-4.20)	4.30 (3.50-5.24)	5.69 (4.63-6.96)	6.84 (5.53-8.42)	8.44 (6.59-10.8)	9.61 (7.34-12.5)	10.9 (8.08-14.6)	12.4 (8.59-16.7)	14.6 (9.74-20.2)	16.5 (10.7-23.2)
10-min	2.44 (2.00-2.98)	3.04 (2.48-3.71)	4.03 (3.27-4.93)	4.85 (3.92-5.96)	5.98 (4.67-7.62)	6.81 (5.21-8.84)	7.71 (5.72-10.3)	8.77 (6.09-11.8)	10.4 (6.89-14.3)	11.7 (7.60-16.4)
15-min	1.92 (1.56-2.34)	2.39 (1.95-2.92)	3.16 (2.57-3.87)	3.80 (3.07-4.67)	4.68 (3.68-5.98)	5.34 (4.08-6.93)	6.05 (4.49-8.10)	6.88 (4.78-9.26)	8.14 (5.41-11.2)	9.19 (5.96-12.9)
30-min	1.38 (1.13-1.69)	1.72 (1.41-2.10)	2.28 (1.85-2.79)	2.74 (2.22-3.37)	3.37 (2.63-4.30)	3.85 (2.94-4.99)	4.35 (3.23-5.83)	4.95 (3.44-6.67)	5.86 (3.90-8.09)	6.63 (4.30-9.28)
60-min	0.903 (0.738-1.10)	1.13 (0.918-1.37)	1.49 (1.21-1.82)	1.79 (1.45-2.20)	2.20 (1.72-2.81)	2.51 (1.92-3.26)	2.84 (2.11-3.81)	3.23 (2.24-4.35)	3.83 (2.55-5.28)	4.33 (2.81-6.06)
2-hr	0.618 (0.508-0.749)	0.768 (0.631-0.932)	1.01 (0.830-1.23)	1.22 (0.990-1.49)	1.50 (1.18-1.90)	1.70 (1.32-2.20)	1.93 (1.45-2.57)	2.20 (1.54-2.94)	2.62 (1.76-3.58)	2.97 (1.95-4.12)
3-hr	0.488 (0.403-0.589)	0.603 (0.498-0.729)	0.792 (0.651-0.959)	0.948 (0.775-1.15)	1.16 (0.921-1.47)	1.32 (1.03-1.70)	1.50 (1.13-1.99)	1.71 (1.20-2.26)	2.02 (1.37-2.75)	2.30 (1.52-3.17)
6-hr	0.320 (0.266-0.383)	0.389 (0.323-0.467)	0.503 (0.416-0.605)	0.597 (0.491-0.721)	0.727 (0.579-0.909)	0.823 (0.643-1.05)	0.927 (0.704-1.22)	1.05 (0.748-1.38)	1.23 (0.844-1.67)	1.39 (0.929-1.90)
12-hr	0.201 (0.168-0.239)	0.240 (0.200-0.286)	0.303 (0.253-0.362)	0.356 (0.295-0.427)	0.429 (0.344-0.531)	0.483 (0.379-0.607)	0.541 (0.412-0.698)	0.606 (0.438-0.791)	0.701 (0.485-0.936)	0.779 (0.526-1.06)
24-hr	0.121 (0.102-0.143)	0.143 (0.121-0.169)	0.179 (0.150-0.212)	0.209 (0.174-0.249)	0.250 (0.202-0.306)	0.281 (0.222-0.349)	0.313 (0.240-0.399)	0.348 (0.254-0.450)	0.398 (0.279-0.527)	0.438 (0.299-0.588)
2-day	0.070 (0.059-0.082)	0.082 (0.070-0.097)	0.103 (0.087-0.121)	0.120 (0.101-0.141)	0.143 (0.118-0.174)	0.161 (0.128-0.198)	0.179 (0.138-0.226)	0.199 (0.146-0.254)	0.226 (0.160-0.297)	0.249 (0.172-0.331)
3-day	0.051 (0.044-0.060)	0.060 (0.051-0.070)	0.074 (0.063-0.087)	0.086 (0.072-0.101)	0.102 (0.083-0.123)	0.114 (0.091-0.140)	0.127 (0.098-0.159)	0.140 (0.104-0.179)	0.159 (0.114-0.208)	0.175 (0.122-0.231)
4-day	0.041 (0.035-0.048)	0.048 (0.041-0.056)	0.059 (0.050-0.068)	0.067 (0.057-0.079)	0.080 (0.065-0.096)	0.089 (0.072-0.109)	0.099 (0.077-0.123)	0.109 (0.081-0.138)	0.124 (0.088-0.160)	0.135 (0.094-0.178)
7-day	0.028 (0.024-0.032)	0.032 (0.027-0.037)	0.038 (0.033-0.044)	0.043 (0.037-0.051)	0.051 (0.042-0.060)	0.056 (0.045-0.068)	0.062 (0.048-0.076)	0.068 (0.051-0.085)	0.076 (0.055-0.098)	0.082 (0.058-0.107)
10-day	0.022 (0.019-0.026)	0.025 (0.022-0.029)	0.030 (0.025-0.034)	0.033 (0.029-0.039)	0.039 (0.032-0.046)	0.043 (0.035-0.051)	0.047 (0.037-0.058)	0.051 (0.038-0.064)	0.057 (0.041-0.073)	0.061 (0.043-0.079)
20-day	0.015 (0.013-0.018)	0.017 (0.015-0.019)	0.019 (0.017-0.022)	0.022 (0.019-0.025)	0.025 (0.021-0.029)	0.027 (0.022-0.032)	0.029 (0.023-0.035)	0.031 (0.024-0.039)	0.034 (0.025-0.043)	0.036 (0.026-0.047)
30-day	0.013 (0.011-0.014)	0.014 (0.012-0.016)	0.016 (0.014-0.018)	0.017 (0.015-0.020)	0.019 (0.016-0.023)	0.021 (0.017-0.025)	0.023 (0.018-0.027)	0.024 (0.019-0.030)	0.026 (0.019-0.033)	0.027 (0.020-0.035)
45-day	0.010 (0.009-0.012)	0.011 (0.010-0.013)	0.013 (0.011-0.014)	0.014 (0.012-0.016)	0.016 (0.013-0.018)	0.017 (0.014-0.020)	0.018 (0.014-0.022)	0.019 (0.015-0.023)	0.020 (0.015-0.026)	0.021 (0.015-0.027)
60-day	0.009 (0.008-0.010)	0.010 (0.009-0.011)	0.011 (0.010-0.012)	0.012 (0.010-0.014)	0.013 (0.011-0.015)	0.014 (0.012-0.017)	0.015 (0.012-0.018)	0.016 (0.013-0.020)	0.017 (0.013-0.021)	0.018 (0.013-0.023)

¹ Precipitation frequency (PF) estimates in this table are based on frequency analysis of partial duration series (PDS). Numbers in parenthesis are PF estimates at lower and upper bounds of the 90% confidence interval. The probability that precipitation frequency estimates (for a given duration and average recurrence interval) will be greater than the upper bound (or less than the lower bound) is 5%. Estimates at upper bounds are not checked against probable maximum precipitation (PMP) estimates and may be higher than currently valid PMP values. Please refer to NOAA Atlas 14 document for more information.

Table 2-2a Runoff curve numbers for urban areas ^{1/}

Cover description	Average percent impervious area ^{2/}	Curve numbers for hydrologic soil group			
		A	B	C	D
Fully developed urban areas (vegetation established)					
Open space (lawns, parks, golf courses, cemeteries, etc.) ^{3/} :					
Poor condition (grass cover < 50%)		68	79	86	89
Fair condition (grass cover 50% to 75%)		49	69	79	84
Good condition (grass cover > 75%)		39	61	74	80
Impervious areas:					
Paved parking lots, roofs, driveways, etc. (excluding right-of-way)		98	98	98	98
Streets and roads:					
Paved; curbs and storm sewers (excluding right-of-way)		98	98	98	98
Paved; open ditches (including right-of-way)		83	89	92	93
Gravel (including right-of-way)		76	85	89	91
Dirt (including right-of-way)		72	82	87	89
Western desert urban areas:					
Natural desert landscaping (pervious areas only) ^{4/}		63	77	85	88
Artificial desert landscaping (impervious weed barrier, desert shrub with 1- to 2-inch sand or gravel mulch and basin borders)		96	96	96	96
Urban districts:					
Commercial and business	85	89	92	94	95
Industrial	72	81	88	91	93
Residential districts by average lot size:					
1/8 acre or less (town houses)	65	77	85	90	92
1/4 acre	38	61	75	83	87
1/3 acre	30	57	72	81	86
1/2 acre	25	54	70	80	85
1 acre	20	51	68	79	84
2 acres	12	46	65	77	82

Developing urban areas

Newly graded areas
(pervious areas only, no vegetation) ^{5/}

	77	86	91	94
--	----	----	----	----

Idle lands (CN's are determined using cover types
similar to those in table 2-2c).

^{1/} Average runoff condition, and $I_a = 0.2S$.

^{2/} The average percent impervious area shown was used to develop the composite CN's. Other assumptions are as follows: impervious areas are directly connected to the drainage system, impervious areas have a CN of 98, and pervious areas are considered equivalent to open space in good hydrologic condition. CN's for other combinations of conditions may be computed using figure 2-3 or 2-4.

^{3/} CN's shown are equivalent to those of pasture. Composite CN's may be computed for other combinations of open space cover type.

^{4/} Composite CN's for natural desert landscaping should be computed using figures 2-3 or 2-4 based on the impervious area percentage (CN = 98) and the pervious area CN. The pervious area CN's are assumed equivalent to desert shrub in poor hydrologic condition.

^{5/} Composite CN's to use for the design of temporary measures during grading and construction should be computed using figure 2-3 or 2-4 based on the degree of development (impervious area percentage) and the CN's for the newly graded pervious areas.

Table 2-2b Runoff curve numbers for cultivated agricultural lands ^{1/}

Cover description			Curve numbers for hydrologic soil group			
Cover type	Treatment ^{2/}	Hydrologic condition ^{3/}	A	B	C	D
Fallow	Bare soil	—	77	86	91	94
	Crop residue cover (CR)	Poor	76	85	90	93
		Good	74	83	88	90
Row crops	Straight row (SR)	Poor	72	81	88	91
		Good	67	78	85	89
	SR + CR	Poor	71	80	87	90
		Good	64	75	82	85
	Contoured (C)	Poor	70	79	84	88
		Good	65	75	82	86
	C + CR	Poor	69	78	83	87
		Good	64	74	81	85
	Contoured & terraced (C&T)	Poor	66	74	80	82
		Good	62	71	78	81
C&T+ CR	Poor	65	73	79	81	
	Good	61	70	77	80	
Small grain	SR	Poor	65	76	84	88
		Good	63	75	83	87
	SR + CR	Poor	64	75	83	86
		Good	60	72	80	84
	C	Poor	63	74	82	85
		Good	61	73	81	84
	C + CR	Poor	62	73	81	84
		Good	60	72	80	83
	C&T	Poor	61	72	79	82
		Good	59	70	78	81
C&T+ CR	Poor	60	71	78	81	
	Good	58	69	77	80	
Close-seeded or broadcast legumes or rotation meadow	SR	Poor	66	77	85	89
		Good	58	72	81	85
	C	Poor	64	75	83	85
		Good	55	69	78	83
	C&T	Poor	63	73	80	83
		Good	51	67	76	80

¹ Average runoff condition, and $I_a=0.2S$

² Crop residue cover applies only if residue is on at least 5% of the surface throughout the year.

³ Hydraulic condition is based on combination factors that affect infiltration and runoff, including (a) density and canopy of vegetative areas, (b) amount of year-round cover, (c) amount of grass or close-seeded legumes, (d) percent of residue cover on the land surface (good $\geq 20\%$), and (e) degree of surface roughness.

Poor: Factors impair infiltration and tend to increase runoff.

Good: Factors encourage average and better than average infiltration and tend to decrease runoff.

Table 2-2c Runoff curve numbers for other agricultural lands ^{1/}

Cover description	Hydrologic condition	Curve numbers for hydrologic soil group			
		A	B	C	D
Pasture, grassland, or range—continuous forage for grazing. ^{2/}	Poor	68	79	86	89
	Fair	49	69	79	84
	Good	39	61	74	80
Meadow—continuous grass, protected from grazing and generally mowed for hay.	—	30	58	71	78
Brush—brush-weed-grass mixture with brush the major element. ^{3/}	Poor	48	67	77	83
	Fair	35	56	70	77
	Good	30 ^{4/}	48	65	73
Woods—grass combination (orchard or tree farm). ^{5/}	Poor	57	73	82	86
	Fair	43	65	76	82
	Good	32	58	72	79
Woods. ^{6/}	Poor	45	66	77	83
	Fair	36	60	73	79
	Good	30 ^{4/}	55	70	77
Farmsteads—buildings, lanes, driveways, and surrounding lots.	—	59	74	82	86

¹ Average runoff condition, and $I_a = 0.2S$.

² **Poor:** <50% ground cover or heavily grazed with no mulch.

Fair: 50 to 75% ground cover and not heavily grazed.

Good: > 75% ground cover and lightly or only occasionally grazed.

³ **Poor:** <50% ground cover.

Fair: 50 to 75% ground cover.

Good: >75% ground cover.

⁴ Actual curve number is less than 30; use CN = 30 for runoff computations.

⁵ CN's shown were computed for areas with 50% woods and 50% grass (pasture) cover. Other combinations of conditions may be computed from the CN's for woods and pasture.

⁶ **Poor:** Forest litter, small trees, and brush are destroyed by heavy grazing or regular burning.

Fair: Woods are grazed but not burned, and some forest litter covers the soil.

Good: Woods are protected from grazing, and litter and brush adequately cover the soil.

Table 2-2d Runoff curve numbers for arid and semiarid rangelands ^{1/}

Cover description		Curve numbers for hydrologic soil group			
Cover type	Hydrologic condition ^{2/}	A ^{3/}	B	C	D
Herbaceous—mixture of grass, weeds, and low-growing brush, with brush the minor element.	Poor		80	87	93
	Fair		71	81	89
	Good		62	74	85
Oak-aspen—mountain brush mixture of oak brush, aspen, mountain mahogany, bitter brush, maple, and other brush.	Poor		66	74	79
	Fair		48	57	63
	Good		30	41	48
Pinyon-juniper—pinyon, juniper, or both; grass understory.	Poor		75	85	89
	Fair		58	73	80
	Good		41	61	71
Sagebrush with grass understory.	Poor		67	80	85
	Fair		51	63	70
	Good		35	47	55
Desert shrub—major plants include saltbush, greasewood, creosotebush, blackbrush, bursage, palo verde, mesquite, and cactus.	Poor	63	77	85	88
	Fair	55	72	81	86
	Good	49	68	79	84

¹ Average runoff condition, and $I_a = 0.2S$. For range in humid regions, use table 2-2c.

² Poor: <30% ground cover (litter, grass, and brush overstory).

Fair: 30 to 70% ground cover.

Good: > 70% ground cover.

³ Curve numbers for group A have been developed only for desert shrub.

Curve Number and Drainage Areas

Computed By: *EC* Date: **8/28/19**
Checked By: *EM* Date: **8/29/19**

EXISTING DRAINAGE AREAS AND CURVE NUMBER					
Land Type	Hydrologic Soil Group	CN	Area A (ac)	Area B (ac)	Area C (ac)
Impervious	-	98	2.64	2.34	1.66
Meadow	B	58	4.97	0.00	0.00
Meadow	A	30	3.02	51.61	1.15
Woods	A	30	75.98	72.73	79.39
Woods	B	55	39.83	0.00	50.09
Gravel	A	76	0.00	0.00	0.00
Total			126.44	126.68	132.29

PROPOSED DRAINAGE AREAS AND CURVE NUMBER					
Land Type	Hydrologic Soil Group	CN	Area A (ac)	Area B (ac)	Area C (ac)
Impervious	-	98	2.39	1.15	1.42
Meadow	B	58	5.52	0.00	0.80
Meadow	A	30	26.74	90.89	22.68
Woods	A	30	41.68	35.05	58.96
Woods	B	55	39.26	0.00	49.38
Gravel	A	76	1.44	6.86	1.22
Total			117.03	133.96	134.46

Figure 3-1

Average velocities for estimating travel time for shallow concentrated flow

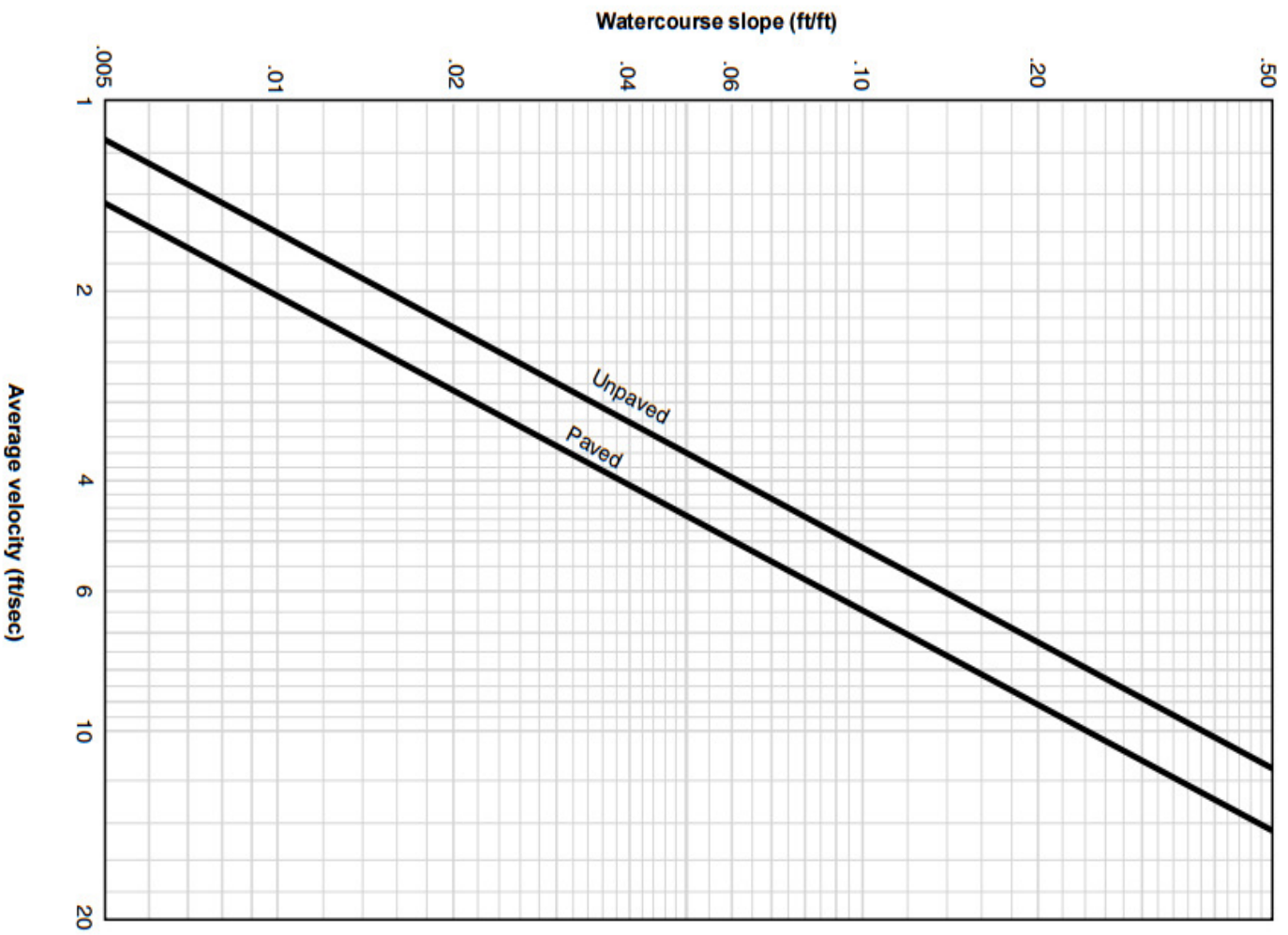

Drainage Area: A (EXISTING)

Sheet Flow:

Surface Description (table 3-1)
Manning's Roughness coeff., n
Flow Length, L (should be <= 300 ft)
Two-yr, 24-hr rainfall, P₂
Land Slope, s
Tt = (0.007 * (n*L)^{0.8}) / (P₂^{0.5} * s^{0.4})

Time of Concentration Calculations

Computed By: *EC* Date: **8/28/19**
Checked By: *EM* Date: **8/29/19**

Grass, dense grasses
0.24 (see Table 3-1 of TR-55 at right)
150 ft
3.44 inches NOAA Atlas 14
0.007 ft/ft
0.48 hr = 28.97 min

Shallow Concentrated Flow:

Surface Description (paved/unpaved)
Flow Length, L
Watercourse slope, s
Average Velocity, V (see Figure 3-1)
Tt = L / (3600 * V)

Unpaved
4300 ft
0.003 ft/ft
1.15 ft/s
1.04 hr = 62.32 min

Total Watershed or subarea Tc	1.52 hr =	91.29 min
--------------------------------------	-----------	-----------

Table 3-1 Roughness coefficients (Manning's n) for sheet flow

Surface description	n ^{1/}
Smooth surfaces (concrete, asphalt, gravel, or bare soil)	0.011
Fallow (no residue)	0.05
Cultivated soils:	
Residue cover ≤20%	0.06
Residue cover >20%	0.17
Grass:	
Short grass prairie	0.15
Dense grasses ^{2/}	0.24
Bermudagrass	0.41
Range (natural)	0.13
Woods: ^{3/}	
Light underbrush	0.40
Dense underbrush	0.80

¹ The n values are a composite of information compiled by Engman (1986).
² Includes species such as weeping lovegrass, bluegrass, buffalo grass, blue grama grass, and native grass mixtures.
³ When selecting n, consider cover to a height of about 0.1 ft. This is the only part of the plant cover that will obstruct sheet flow.

Drainage Area: B (EXISTING)

Sheet Flow:

Surface Description (table 3-1)
Manning's Roughness coeff., n
Flow Length, L (should be <= 300 ft)
Two-yr, 24-hr rainfall, P2
Land Slope, s
Tt = (0.007 * (n*L)^{0.8}) / (P₂^{0.5} * s^{0.4})

Time of Concentration Calculations

Computed By: *EC* Date: **8/28/19**
Checked By: *EM* Date: **8/29/19**

Grass, dense grasses
0.24 (see Table 3-1 of TR-55 at right)
150 ft
3.44 inches NOAA Atlas 14
0.007 ft/ft
0.48 hr = 28.97 min

Shallow Concentrated Flow:

Surface Description (paved/unpaved)
Flow Length, L
Watercourse slope, s
Average Velocity, V (see Figure 3-1)
Tt = L / (3600 * V)

Unpaved
5287 ft
0.009 ft/ft
1.5 ft/s
0.98 hr = 58.74 min

Total Watershed or subarea Tc	1.46 hr =	87.72 min
--------------------------------------	-----------	-----------

Table 3-1 Roughness coefficients (Manning's n) for sheet flow

Surface description	n ^{1/}
Smooth surfaces (concrete, asphalt, gravel, or bare soil)	0.011
Fallow (no residue)	0.05
Cultivated soils:	
Residue cover ≤20%	0.06
Residue cover >20%	0.17
Grass:	
Short grass prairie	0.15
Dense grasses ^{2/}	0.24
Bermudagrass	0.41
Range (natural)	0.13
Woods: ^{3/}	
Light underbrush	0.40
Dense underbrush	0.80

¹ The n values are a composite of information compiled by Engman (1986).
² Includes species such as weeping lovegrass, bluegrass, buffalo grass, blue grama grass, and native grass mixtures.
³ When selecting n, consider cover to a height of about 0.1 ft. This is the only part of the plant cover that will obstruct sheet flow.

Project: MPMG Range
JOB No.

Drainage Area: C (EXISTING)

Sheet Flow:

Surface Description (table 3-1)
Manning's Roughness coeff., n
Flow Length, L (should be <= 300 ft)
Two-yr, 24-hr rainfall, P2
Land Slope, s
Tt = $(0.007 * (n * L)^{0.8}) / (P_2^{0.5} * s^{0.4})$

Time of Concentration Calculations

Computed By: *EC* Date: **8/28/19**
Checked By: *EM* Date: **8/29/19**

Woods, light underbrush
0.4 (see Table 3-1 of TR-55 at right)
150 ft
3.44 inches NOAA Atlas 14
0.008 ft/ft
0.69 hr = 41.33 min

Shallow Concentrated Flow:

Surface Description (paved/unpaved)
Flow Length, L
Watercourse slope, s
Average Velocity, V (see Figure 3-1)
Tt = L / (3600 * V)

Unpaved
4620 ft
0.018 ft/ft
2.2 ft/s
0.58 hr = 35.00 min

Total Watershed or subarea Tc	1.27 hr =	76.33 min
--------------------------------------	-----------	-----------

Table 3-1 Roughness coefficients (Manning's n) for sheet flow

Surface description	n ^{1/}
Smooth surfaces (concrete, asphalt, gravel, or bare soil)	0.011
Fallow (no residue)	0.05
Cultivated soils:	
Residue cover ≤20%	0.06
Residue cover >20%	0.17
Grass:	
Short grass prairie	0.15
Dense grasses ^{2/}	0.24
Bermudagrass	0.41
Range (natural)	0.13
Woods: ^{3/}	
Light underbrush	0.40
Dense underbrush	0.80

¹ The n values are a composite of information compiled by Engman (1986).

² Includes species such as weeping lovegrass, bluegrass, buffalo grass, blue grama grass, and native grass mixtures.

³ When selecting n, consider cover to a height of about 0.1 ft. This is the only part of the plant cover that will obstruct sheet flow.

Project: MPMG Range
JOB No.

Table 3-1 Roughness coefficients (Manning's n) for sheet flow

Surface description	n ^{1/}
Smooth surfaces (concrete, asphalt, gravel, or bare soil)	0.011
Fallow (no residue)	0.05
Cultivated soils:	
Residue cover ≤20%	0.06
Residue cover >20%	0.17
Grass:	
Short grass prairie	0.15
Dense grasses ^{2/}	0.24
Bermudagrass	0.41
Range (natural)	0.13
Woods: ^{3/}	
Light underbrush	0.40
Dense underbrush	0.80

¹ The n values are a composite of information compiled by Engman (1986).
² Includes species such as weeping lovegrass, bluegrass, buffalo grass, blue grama grass, and native grass mixtures.
³ When selecting n, consider cover to a height of about 0.1 ft. This is the only part of the plant cover that will obstruct sheet flow.

Time of Concentration Calculations

Computed By: **EC** Date: **8/28/19**
 Checked By: **EM** Date: **8/29/19**

Drainage Area: A (PROPOSED)

Sheet Flow:

Surface Description (table 3-1)
 Manning's Roughness coeff., n
 Flow Length, L (should be ≤ 300 ft)
 Two-yr, 24-hr rainfall, P2
 Land Slope, s
 $Tt = (0.007 * (n * L)^{0.8}) / (P_2^{0.5} * s^{0.4})$

Grass, dense grasses
 0.24 (see Table 3-1 of TR-55 at right)
 150 ft
 3.44 inches NOAA Atlas 14
 0.007 ft/ft
 0.48 hr = 28.97 min

Shallow Concentrated Flow:

Surface Description (paved/unpaved)
 Flow Length, L
 Watercourse slope, s
 Average Velocity, V (see Figure 3-1)
 $Tt = L / (3600 * V)$

Unpaved
 4372 ft
 0.004 ft/ft
 1.18 ft/s
 1.03 hr = 61.75 min

Total Watershed or subarea Tc	1.51 hr =	90.72 min
--------------------------------------	-----------	-----------

Project: MPMG Range
JOB No.

Table 3-1 Roughness coefficients (Manning's n) for sheet flow

Surface description	n ^{1/}
Smooth surfaces (concrete, asphalt, gravel, or bare soil)	0.011
Fallow (no residue)	0.05
Cultivated soils:	
Residue cover ≤20%	0.06
Residue cover >20%	0.17
Grass:	
Short grass prairie	0.15
Dense grasses ^{2/}	0.24
Bermudagrass	0.41
Range (natural)	0.13
Woods: ^{3/}	
Light underbrush	0.40
Dense underbrush	0.80

¹ The n values are a composite of information compiled by Engman (1986).
² Includes species such as weeping lovegrass, bluegrass, buffalo grass, blue grama grass, and native grass mixtures.
³ When selecting n, consider cover to a height of about 0.1 ft. This is the only part of the plant cover that will obstruct sheet flow.

Time of Concentration Calculations

Computed By: **EC** Date: **8/28/19**
 Checked By: **EM** Date: **8/29/19**

Drainage Area: B (PROPOSED)

Sheet Flow:

Surface Description (table 3-1)
 Manning's Roughness coeff., n
 Flow Length, L (should be ≤ 300 ft)
 Two-yr, 24-hr rainfall, P₂
 Land Slope, s
 $Tt = (0.007 * (n * L)^{0.8}) / (P_2^{0.5} * s^{0.4})$

Grass, dense grasses
 0.24 (see Table 3-1 of TR-55 at right)
 150 ft
 3.44 inches NOAA Atlas 14
 0.007 ft/ft
 0.48 hr = 28.97 min

Shallow Concentrated Flow:

Surface Description (paved/unpaved)
 Flow Length, L
 Watercourse slope, s
 Average Velocity, V (see Figure 3-1)
 $Tt = L / (3600 * V)$

Unpaved
 5158 ft
 0.009 ft/ft
 1.6 ft/s
 0.90 hr = 53.73 min

Total Watershed or subarea Tc	1.38 hr =	82.70 min
--------------------------------------	-----------	-----------

Project: MPMG Range
JOB No.

Table 3-1 Roughness coefficients (Manning's n) for sheet flow

Surface description	n ^{1/}
Smooth surfaces (concrete, asphalt, gravel, or bare soil)	0.011
Fallow (no residue)	0.05
Cultivated soils:	
Residue cover ≤20%	0.06
Residue cover >20%	0.17
Grass:	
Short grass prairie	0.15
Dense grasses ^{2/}	0.24
Bermudagrass	0.41
Range (natural)	0.13
Woods: ^{3/}	
Light underbrush	0.40
Dense underbrush	0.80

¹ The n values are a composite of information compiled by Engman (1986).

² Includes species such as weeping lovegrass, bluegrass, buffalo grass, blue grama grass, and native grass mixtures.

³ When selecting n, consider cover to a height of about 0.1 ft. This is the only part of the plant cover that will obstruct sheet flow.

Time of Concentration Calculations

Computed By: **EC** Date: **8/28/19**
Checked By: **EM** Date: **8/29/19**

Drainage Area: C (PROPOSED)

Sheet Flow:

Surface Description (table 3-1)
Manning's Roughness coeff., n
Flow Length, L (should be ≤ 300 ft)
Two-yr, 24-hr rainfall, P₂
Land Slope, s
Tt = (0.007 * (n*L)^{0.8}) / (P₂^{0.5} * s^{0.4})

Woods, light underbrush
 0.4 (see Table 3-1 of TR-55 at right)
 150 ft
 3.44 inches NOAA Atlas 14
 0.008 ft/ft
 0.69 hr = 41.33 min

Shallow Concentrated Flow:

Surface Description (paved/unpaved)
Flow Length, L
Watercourse slope, s
Average Velocity, V (see Figure 3-1)
Tt = L / (3600 * V)

Unpaved
 4509 ft
 0.018 ft/ft
 2.2 ft/s
 0.57 hr = 34.16 min

Total Watershed or subarea Tc	1.26 hr =	75.49 min
--------------------------------------	-----------	-----------

Project: Automated Multipurpose Machine Gun Range

Michael Baker

Subject: Riprap Calculations

INTERNATIONAL

Computed by: EDC Date: 1/24/2020

Checked by: EJM Date: 2/10/2020

Location: ROCA OUTFLOW FROM BASIN

10 YR Flow Rate from Hydrographs

Q₁₀ = 0.22 cfs (See Note 1)

Apron Dimensions

Q = 0.22 cfs (See Note 1)

D_o = 1.50 ft.

q = 0.15

TW = 0.30 ft. (See Note 2)

L_a = 11 ft.

W = 15 ft.

Riprap

TW = 0.30 ft. (See Note 2)

d₅₀ = 0.01 ft.

***Minimum median stone diameter of 0.5 ft. used**

d₅₀ = 0.5

t = 1.0 ft. (See Note 3)

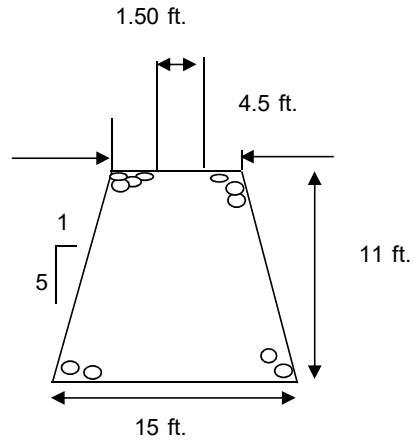

Notes:

1. The 25 yr flow (Q) was calculated using the rational method

2. Tw is computed using Tw=0.2D_o

3. Riprap lining thickness (t) of 2*d₅₀.

Calculated d₅₀ or minimum 0.5ft requirement used in calculation, whichever is greater.

4. Min Length and Width 5' x 5' will be used

Project: Automated Multipurpose Machine Gun Range

Michael Baker

Subject: Riprap Calculations

INTERNATIONAL

Computed by: EDC

Date: 1/24/2020

Checked by: EJM

Date: 2/10/2020

Location: FAN FOREBAY INFLOW

10 YR Flow Rate from Hydrographs

Q₁₀ = 1.01 cfs (See Note 1)

Apron Dimensions

Q = 1.01 cfs (See Note 1)

D_o = 1.50 ft.

q = 0.67

TW = 0.30 ft. (See Note 2)

L_a = 11 ft.

W = 16 ft.

Riprap

TW = 0.30 ft. (See Note 2)

d₅₀ = 0.04 ft.

***Minimum median stone diameter of 0.5 ft. used**

d₅₀ = 0.5

t = 1.0 ft. (See Note 3)

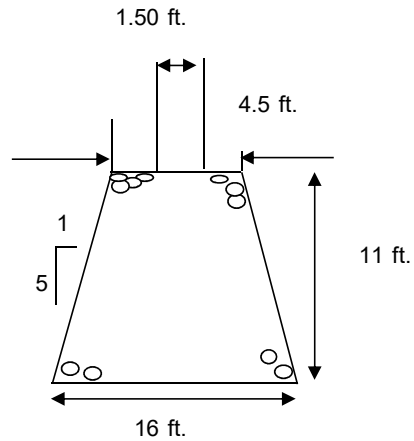

Notes:

1. The 25 yr flow (Q) was calculated using the rational method

2. Tw is computed using Tw=0.2D_o

3. Riprap lining thickness (t) of 2*d₅₀.

Calculated d₅₀ or minimum 0.5ft requirement used in calculation, whichever is greater.

4. Min Length and Width 5' x 5' will be used

Project: Automated Multipurpose Machine Gun Range

Michael Baker

Subject: Riprap Calculations

INTERNATIONAL

Computed by: EDC Date: 1/24/2020

Checked by: EJM Date: 2/10/2020

Location: FAN FOREBAY OUTFLOW

10 YR Flow Rate from Hydrographs

Q₁₀ = 1.01 cfs (See Note 1)

Apron Dimensions

Q = 1.01 cfs (See Note 1)

D_o = 1.50 ft.

q = 0.67

TW = 0.30 ft. (See Note 2)

L_a = 11 ft.

W = 16 ft.

Riprap

TW = 0.30 ft. (See Note 2)

d₅₀ = 0.04 ft.

***Minimum median stone diameter of 0.5 ft. used**

d₅₀ = 0.5

t = 1.0 ft. (See Note 3)

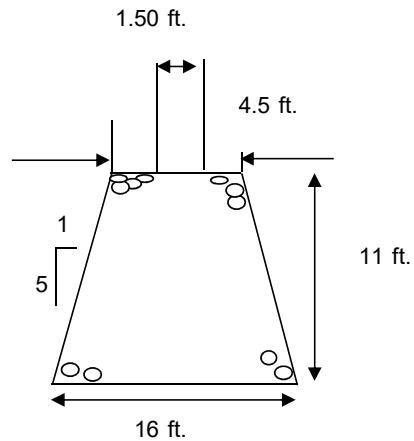

Notes:

1. The 25 yr flow (Q) was calculated using the rational method

2. Tw is computed using Tw=0.2D_o

3. Riprap lining thickness (t) of 2*d₅₀.

Calculated d₅₀ or minimum 0.5ft requirement used in calculation, whichever is greater.

4. Min Length and Width 5' x 5' will be used

Project: Automated Multipurpose Machine Gun Range

Michael Baker

Subject: Riprap Calculations

INTERNATIONAL

Computed by: EDC

Date: 1/24/2020

Checked by: EJM

Date: 2/10/2020

Location: FAN BASIN OUTFLOW

10 YR Flow Rate from Hydrographs

Q₁₀ = 0.20 cfs (See Note 1)

Apron Dimensions

Q = 0.20 cfs (See Note 1)

D_o = 1.50 ft.

q = 0.13

TW = 0.30 ft. (See Note 2)

L_a = 11 ft.

W = 15 ft.

Riprap

TW = 0.30 ft. (See Note 2)

d₅₀ = 0.00 ft.

***Minimum median stone diameter of 0.5 ft. used**

d₅₀ = 0.5

t = 1.0 ft. (See Note 3)

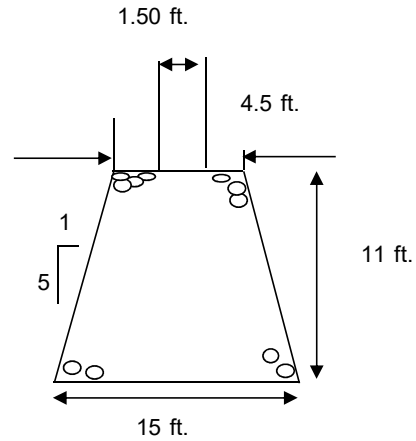

Notes:

1. The 25 yr flow (Q) was calculated using the rational method

2. Tw is computed using Tw=0.2D_o

3. Riprap lining thickness (t) of 2*d₅₀.

Calculated d₅₀ or minimum 0.5ft requirement used in calculation, whichever is greater.

4. Min Length and Width 5' x 5' will be used

Hydrograph Return Period Recap

Hyd. No.	Hydrograph type (origin)	Inflow Hyd(s)	Peak Outflow (cfs)								Hydrograph description
			1-Yr	2-Yr	3-Yr	5-Yr	10-Yr	25-Yr	50-Yr	100-Yr	
1	SCS Runoff	-----	-----	2.72	-----	3.42	4.00	4.79	5.39	6.01	Exist-A-Imp
2	SCS Runoff	-----	-----	0.15	-----	1.30	3.62	9.92	17.36	27.70	Exist-A-Perv
3	Combine	1, 2	-----	2.72	-----	3.42	5.70	13.38	21.75	32.99	Exist-A
5	SCS Runoff	-----	-----	2.62	-----	3.29	3.85	4.62	5.20	5.80	Prop-A-Imp
6	SCS Runoff	-----	-----	0.21	-----	1.55	4.18	11.39	19.64	30.73	Prop-A-Perv
7	Combine	5, 6	-----	2.62	-----	3.35	6.37	14.96	24.05	35.94	Prop-A
10	SCS Runoff	-----	-----	2.57	-----	3.23	3.77	4.52	5.09	5.68	Exist-B-Imp
11	SCS Runoff	-----	-----	0.00	-----	0.00	0.16	1.07	2.78	5.57	Exist-B-Perv
12	Combine	10, 11	-----	2.57	-----	3.23	3.77	4.52	5.23	8.39	Exist-B
14	SCS Runoff	-----	-----	0.13	-----	0.17	0.19	0.23	0.26	0.29	Prop-B-Imp
15	SCS Runoff	-----	-----	0.00	-----	0.00	0.09	0.49	1.11	2.20	Prop-B-Perv
17	SCS Runoff	-----	-----	0.69	-----	0.86	1.01	1.21	1.36	1.52	Prop-B-Imp-FAN-Basin
18	SCS Runoff	-----	-----	0.00	-----	0.01	0.28	1.45	3.12	6.04	Prop-B-Perv-FAN-Basin
19	Combine	17, 18	-----	0.69	-----	0.86	1.01	1.61	3.49	6.84	FAN Basin Inflow
20	Reservoir	19	-----	0.02	-----	0.04	0.20	0.68	1.00	2.33	FAN Basin 1 Routing
21	SCS Runoff	-----	-----	0.22	-----	0.28	0.32	0.39	0.44	0.49	Prop-B-Imp-ROCA-Basin
22	SCS Runoff	-----	-----	0.01	-----	0.08	0.25	0.73	1.37	2.24	Prop-B-Perv-ROCA-Basin
23	Combine	21, 22	-----	0.22	-----	0.28	0.39	0.99	1.72	2.65	ROCA Basin Inflow
24	Reservoir	23	-----	0.02	-----	0.08	0.22	0.49	0.70	0.91	ROCA Basin Routing
25	Combine	14, 15,	-----	0.13	-----	0.17	0.19	0.51	1.15	2.31	Prop-B
26	Combine	20, 24, 25	-----	0.13	-----	0.17	0.42	1.48	2.53	4.20	Prop-B
29	SCS Runoff	-----	-----	1.95	-----	2.45	2.87	3.43	3.87	4.31	Exist-C-Imp
30	SCS Runoff	-----	-----	0.24	-----	1.75	4.79	13.61	23.82	37.55	Exist-C-Perv
31	Combine	29, 30	-----	1.95	-----	2.49	6.16	16.21	27.03	41.38	Exist-C

Hydrograph Return Period Recap

Hyd. No.	Hydrograph type (origin)	Inflow Hyd(s)	Peak Outflow (cfs)								Hydrograph description
			1-Yr	2-Yr	3-Yr	5-Yr	10-Yr	25-Yr	50-Yr	100-Yr	
33	SCS Runoff	-----	-----	1.67	-----	2.10	2.45	2.94	3.31	3.69	Prop-C-Imp
34	SCS Runoff	-----	-----	0.24	-----	1.78	4.88	13.86	24.26	38.24	Prop-C-Perv
35	Combine	33, 34	-----	1.67	-----	2.14	5.99	16.04	27.00	41.52	Prop-C

Hydrograph Summary Report

Hyd. No.	Hydrograph type (origin)	Peak flow (cfs)	Time interval (min)	Time to peak (min)	Volume (cuft)	Inflow hyd(s)	Maximum elevation (ft)	Maximum storage (cuft)	Hydrograph description
1	SCS Runoff	2.72	6	780	31,114	---	-----	-----	Exist-A-Imp
2	SCS Runoff	0.15	6	1434	2,773	---	-----	-----	Exist-A-Perv
3	Combine	2.72	6	780	33,887	1, 2	-----	-----	Exist-A
5	SCS Runoff	2.62	6	774	27,820	---	-----	-----	Prop-A-Imp
6	SCS Runoff	0.21	6	1374	5,217	---	-----	-----	Prop-A-Perv
7	Combine	2.62	6	774	33,037	5, 6	-----	-----	Prop-A
10	SCS Runoff	2.57	6	774	27,238	---	-----	-----	Exist-B-Imp
11	SCS Runoff	0.00	6	0	0	---	-----	-----	Exist-B-Perv
12	Combine	2.57	6	774	27,238	10, 11	-----	-----	Exist-B
14	SCS Runoff	0.13	6	774	1,397	---	-----	-----	Prop-B-Imp
15	SCS Runoff	0.00	6	0	0	---	-----	-----	Prop-B-Perv
17	SCS Runoff	0.69	6	774	7,287	---	-----	-----	Prop-B-Imp-FAN-Basin
18	SCS Runoff	0.00	6	0	0	---	-----	-----	Prop-B-Perv-FAN-Basin
19	Combine	0.69	6	774	7,287	17, 18	-----	-----	FAN Basin Inflow
20	Reservoir	0.02	6	1434	4,150	19	154.43	6,547	FAN Basin 1 Routing
21	SCS Runoff	0.22	6	774	2,328	---	-----	-----	Prop-B-Imp-ROCA-Basin
22	SCS Runoff	0.01	6	1440	74	---	-----	-----	Prop-B-Perv-ROCA-Basin
23	Combine	0.22	6	774	2,402	21, 22	-----	-----	ROCA Basin Inflow
24	Reservoir	0.02	6	1020	1,275	23	154.67	1,840	ROCA Basin Routing
25	Combine	0.13	6	774	1,397	14, 15,	-----	-----	Prop-B
26	Combine	0.13	6	774	6,822	20, 24, 25	-----	-----	Prop-B
29	SCS Runoff	1.95	6	768	19,021	---	-----	-----	Exist-C-Imp
30	SCS Runoff	0.24	6	1368	5,853	---	-----	-----	Exist-C-Perv
31	Combine	1.95	6	768	24,874	29, 30	-----	-----	Exist-C

Hydrograph Summary Report

Hyd. No.	Hydrograph type (origin)	Peak flow (cfs)	Time interval (min)	Time to peak (min)	Volume (cuft)	Inflow hyd(s)	Maximum elevation (ft)	Maximum storage (cuft)	Hydrograph description
33	SCS Runoff	1.67	6	768	16,271	---	-----	-----	Prop-C-Imp
34	SCS Runoff	0.24	6	1368	5,961	---	-----	-----	Prop-C-Perv
35	Combine	1.67	6	768	22,232	33, 34	-----	-----	Prop-C
Camp Edwards Joint Base Cape Cod						Retention Period: 1 Year		Tuesday, Feb 11 2020, 10:32 AM	

Hydrograph Plot

Hyd. No. 1

Exist-A-Imp

Hydrograph type = SCS Runoff
Storm frequency = 2 yrs
Drainage area = 2.64 ac
Basin Slope = 0.0 %
Tc method = USER
Total precip. = 3.44 in
Storm duration = 24 hrs

Peak discharge = 2.72 cfs
Time interval = 6 min
Curve number = 98
Hydraulic length = 0 ft
Time of conc. (Tc) = 91.29 min
Distribution = Type III
Shape factor = 484

Hydrograph Volume = 31,114 cuft

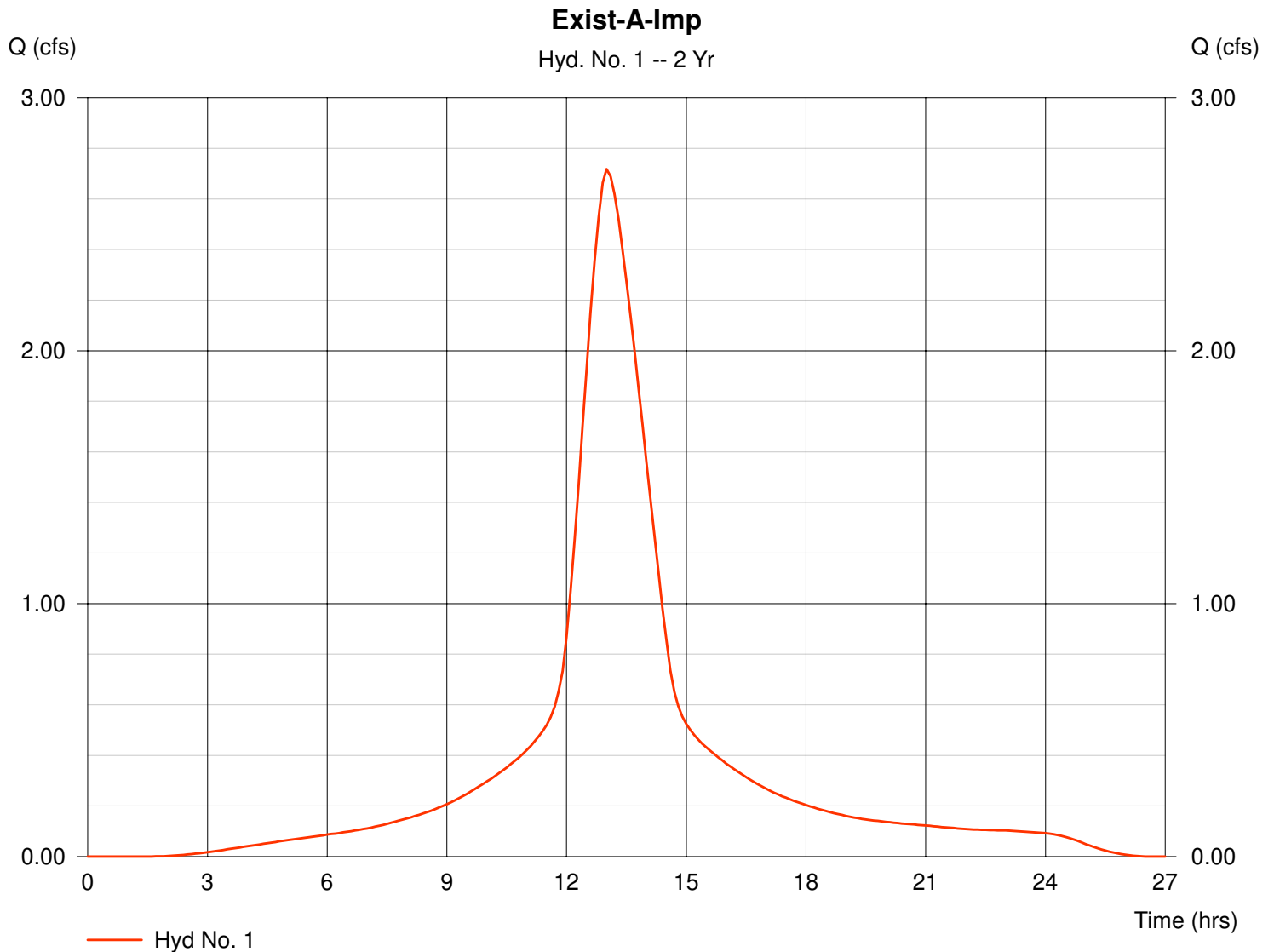

Hydrograph Plot

Hyd. No. 2

Exist-A-Perv

Hydrograph type = SCS Runoff
Storm frequency = 2 yrs
Drainage area = 123.80 ac
Basin Slope = 0.0 %
Tc method = USER
Total precip. = 3.44 in
Storm duration = 24 hrs

Peak discharge = 0.15 cfs
Time interval = 6 min
Curve number = 39
Hydraulic length = 0 ft
Time of conc. (Tc) = 91.29 min
Distribution = Type III
Shape factor = 484

Hydrograph Volume = 2,773 cuft

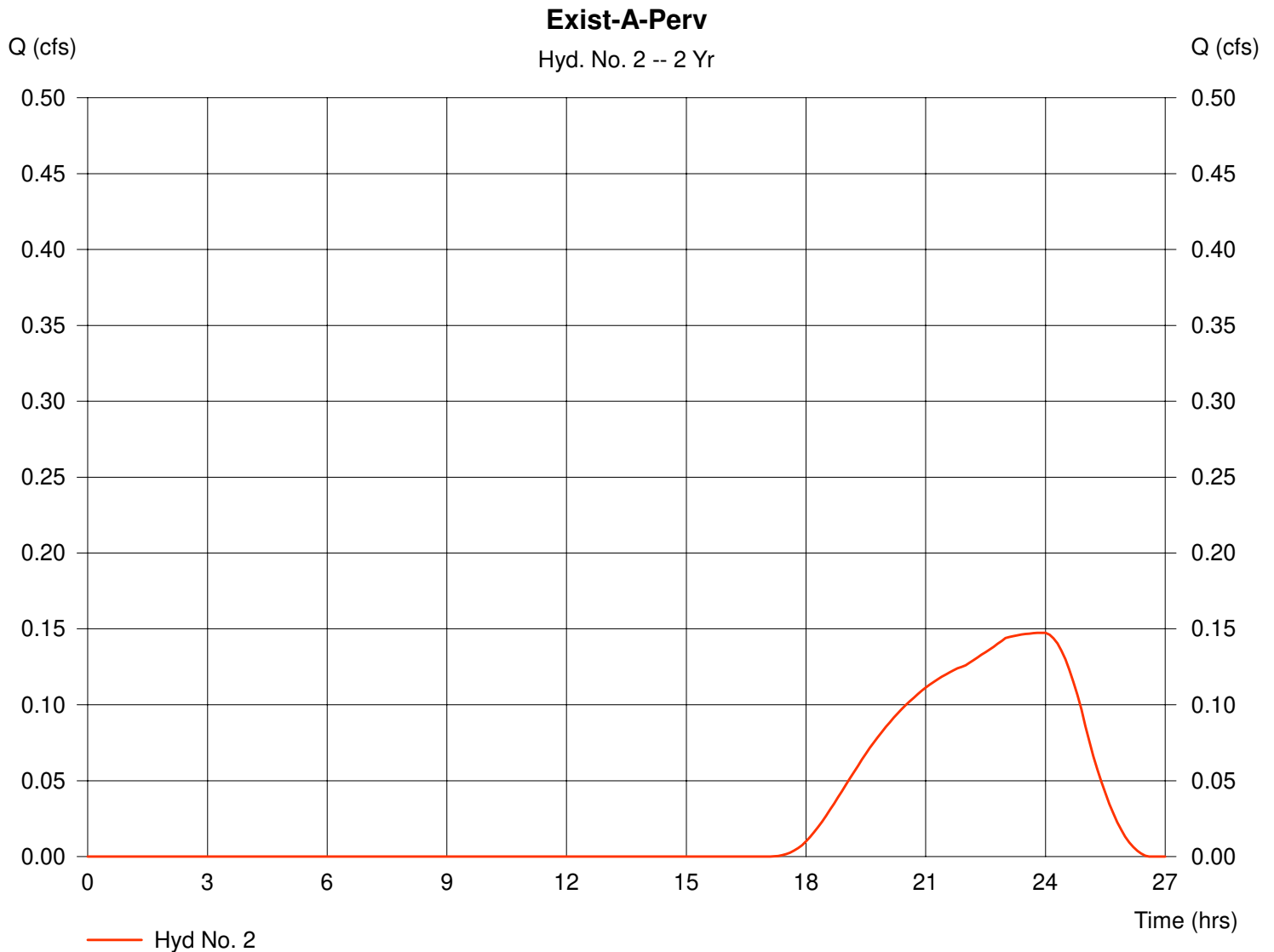

Hydrograph Plot

Hydraflow Hydrographs by Intelisolve

Tuesday, Feb 11 2020, 10:32 AM

Hyd. No. 3

Exist-A

Hydrograph type = Combine
Storm frequency = 2 yrs
Inflow hyds. = 1, 2

Peak discharge = 2.72 cfs
Time interval = 6 min

Hydrograph Volume = 33,887 cuft

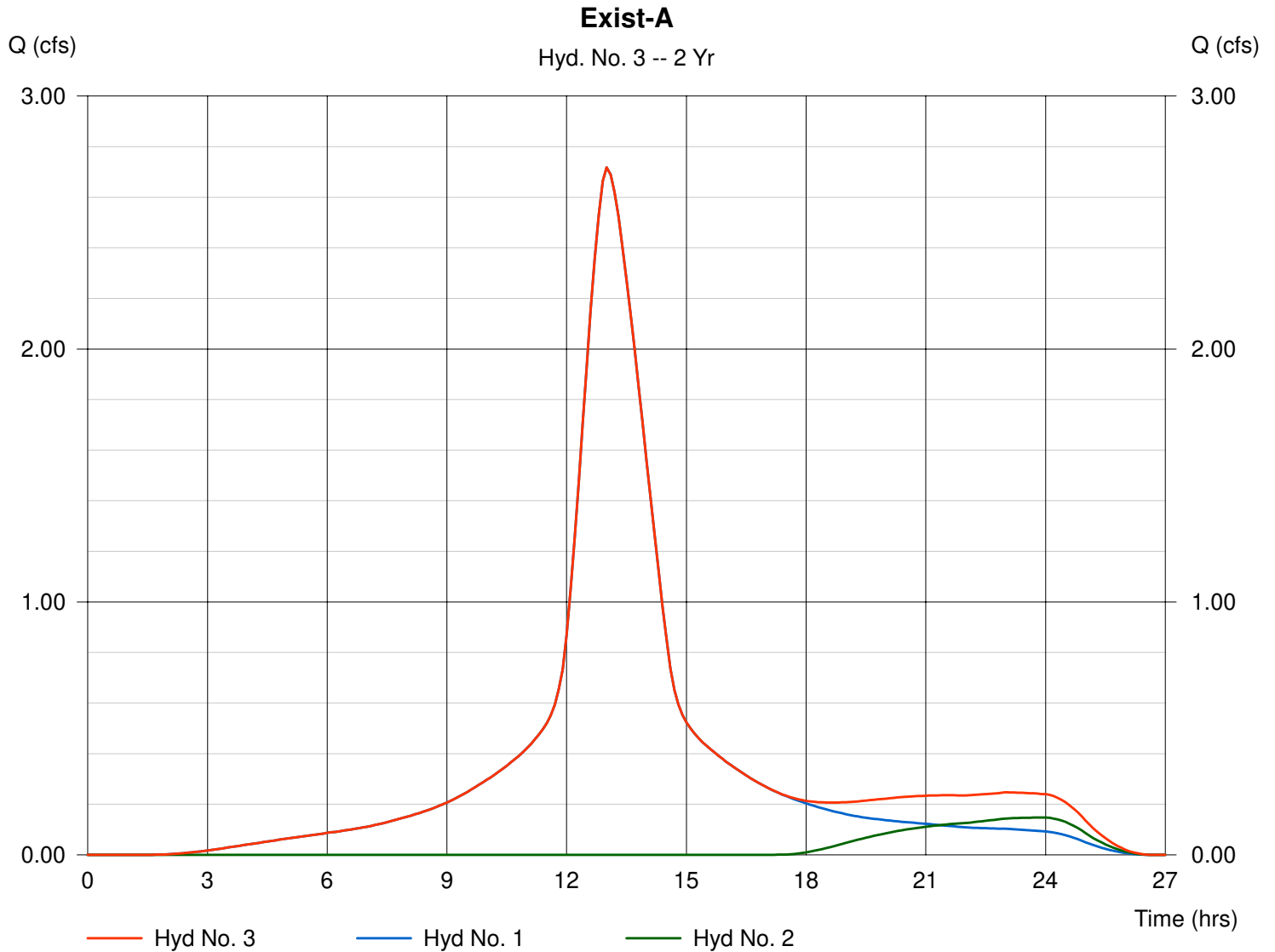

Hydrograph Plot

Hydraflow Hydrographs by Intelisolve

Tuesday, Feb 11 2020, 10:32 AM

Hyd. No. 5

Prop-A-Imp

Hydrograph type = SCS Runoff
Storm frequency = 2 yrs
Drainage area = 2.39 ac
Basin Slope = 0.0 %
Tc method = USER
Total precip. = 3.44 in
Storm duration = 24 hrs

Peak discharge = 2.62 cfs
Time interval = 6 min
Curve number = 98
Hydraulic length = 0 ft
Time of conc. (Tc) = 90.72 min
Distribution = Type III
Shape factor = 484

Hydrograph Volume = 27,820 cuft

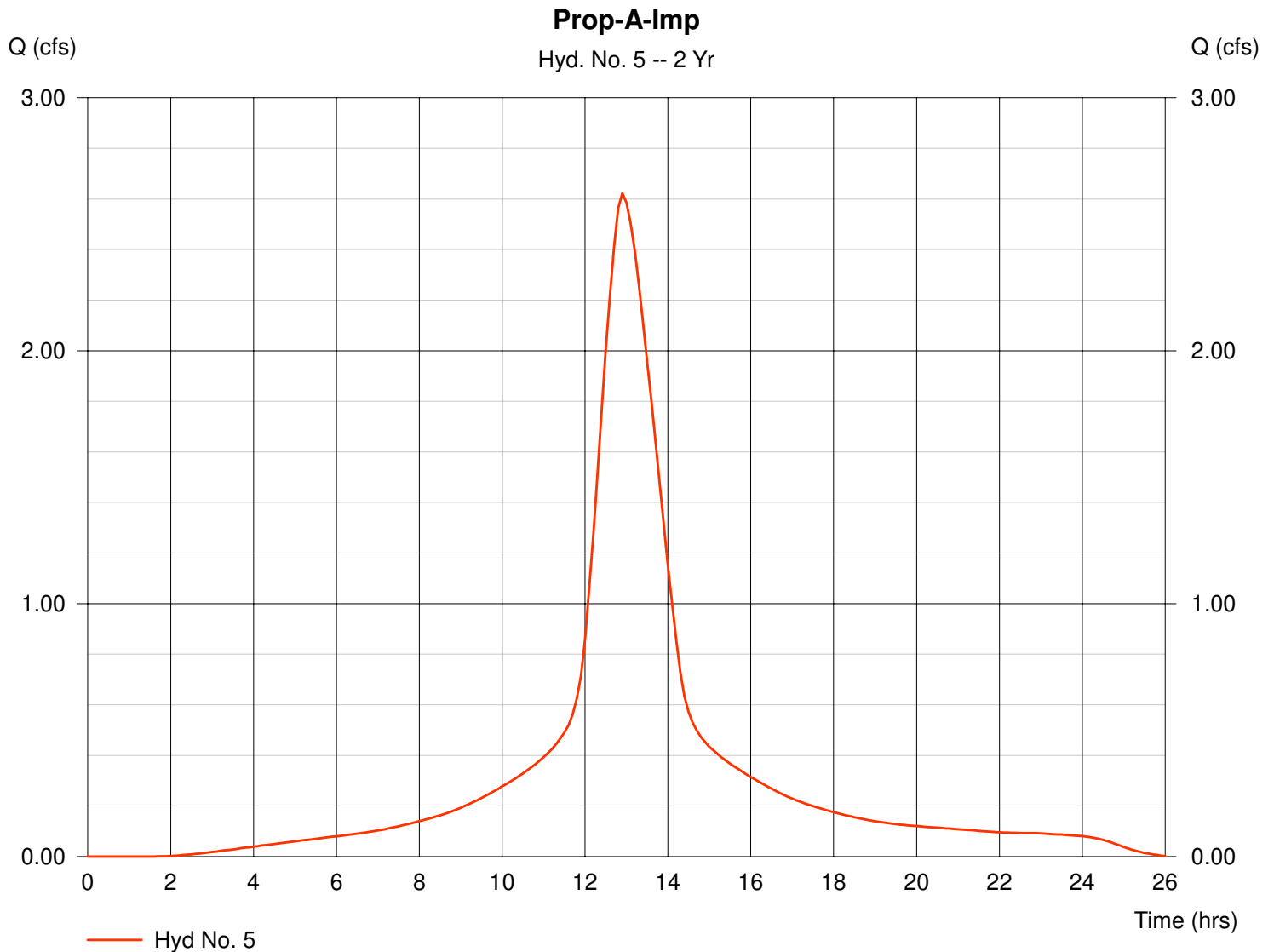

Hydrograph Plot

Hyd. No. 6

Prop-A-Perv

Hydrograph type = SCS Runoff
Storm frequency = 2 yrs
Drainage area = 114.63 ac
Basin Slope = 0.0 %
Tc method = USER
Total precip. = 3.44 in
Storm duration = 24 hrs

Peak discharge = 0.21 cfs
Time interval = 6 min
Curve number = 40
Hydraulic length = 0 ft
Time of conc. (Tc) = 90.7 min
Distribution = Type III
Shape factor = 484

Hydrograph Volume = 5,217 cuft

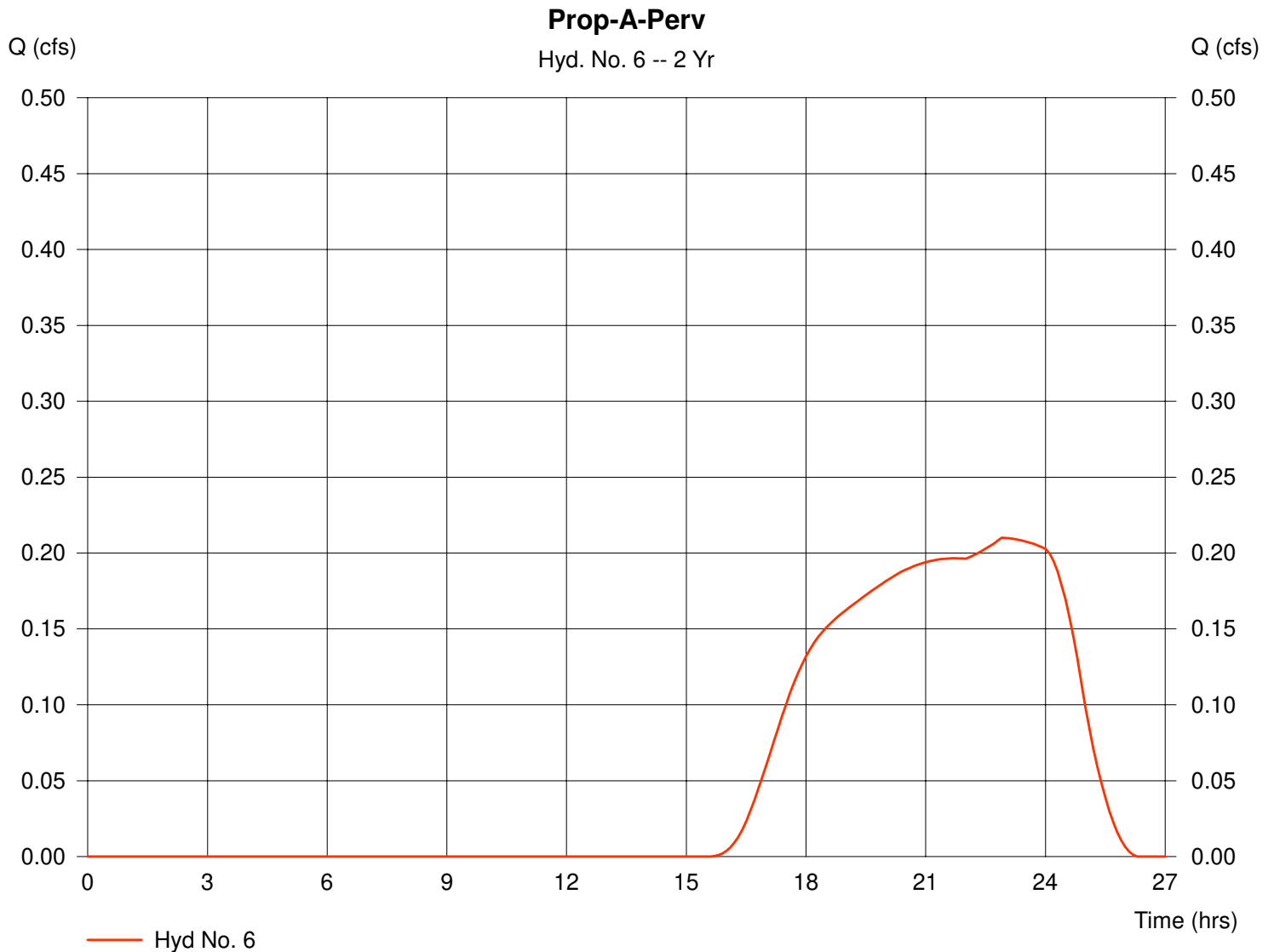

Hydrograph Plot

Hydraflow Hydrographs by Intelisolve

Tuesday, Feb 11 2020, 10:32 AM

Hyd. No. 7

Prop-A

Hydrograph type = Combine
Storm frequency = 2 yrs
Inflow hyds. = 5, 6

Peak discharge = 2.62 cfs
Time interval = 6 min

Hydrograph Volume = 33,037 cuft

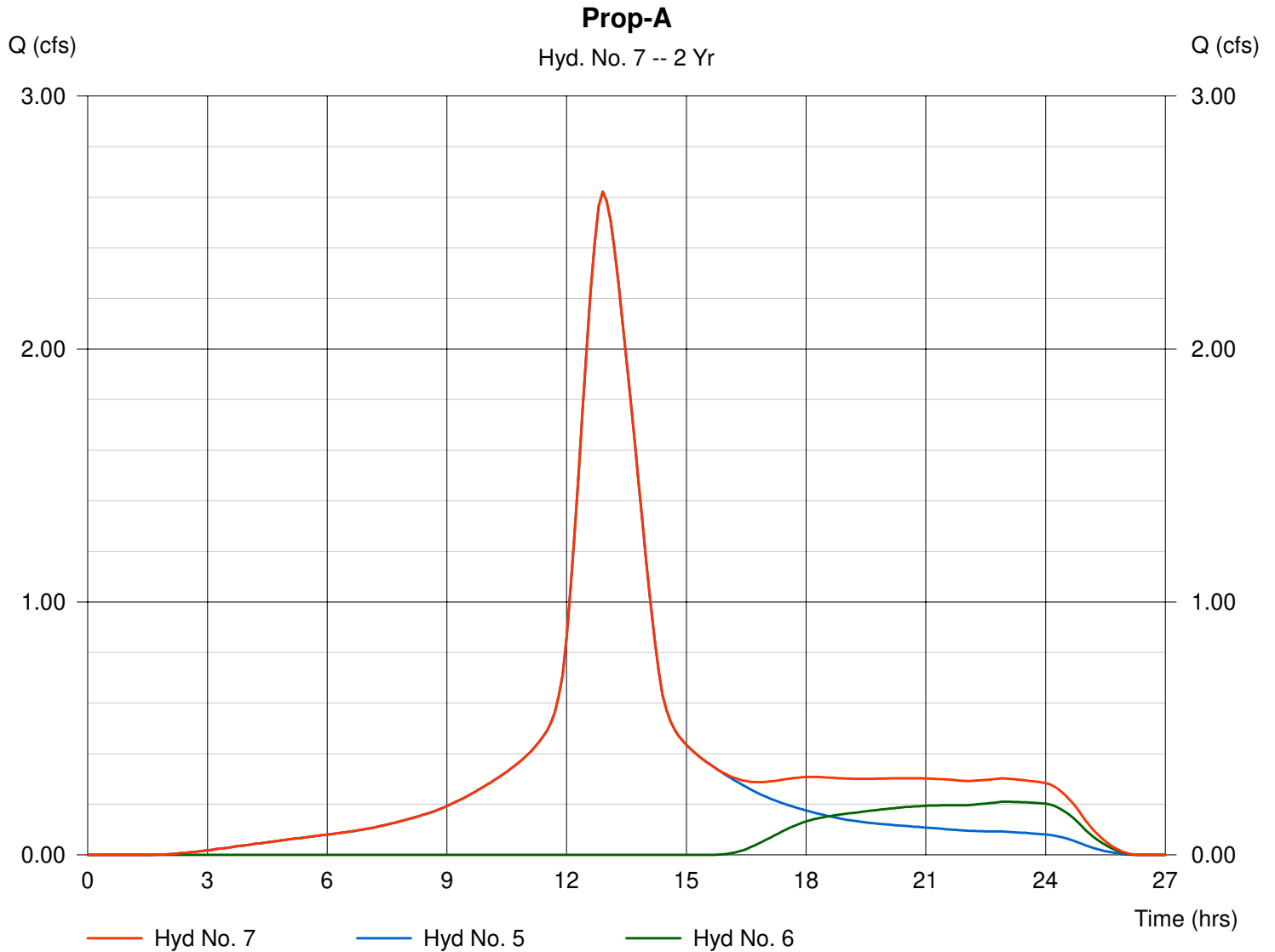

Hydrograph Plot

Hydraflow Hydrographs by Intelisolve

Tuesday, Feb 11 2020, 10:32 AM

Hyd. No. 10

Exist-B-Imp

Hydrograph type = SCS Runoff
Storm frequency = 2 yrs
Drainage area = 2.34 ac
Basin Slope = 0.0 %
Tc method = USER
Total precip. = 3.44 in
Storm duration = 24 hrs

Peak discharge = 2.57 cfs
Time interval = 6 min
Curve number = 98
Hydraulic length = 0 ft
Time of conc. (Tc) = 87.72 min
Distribution = Type III
Shape factor = 484

Hydrograph Volume = 27,238 cuft

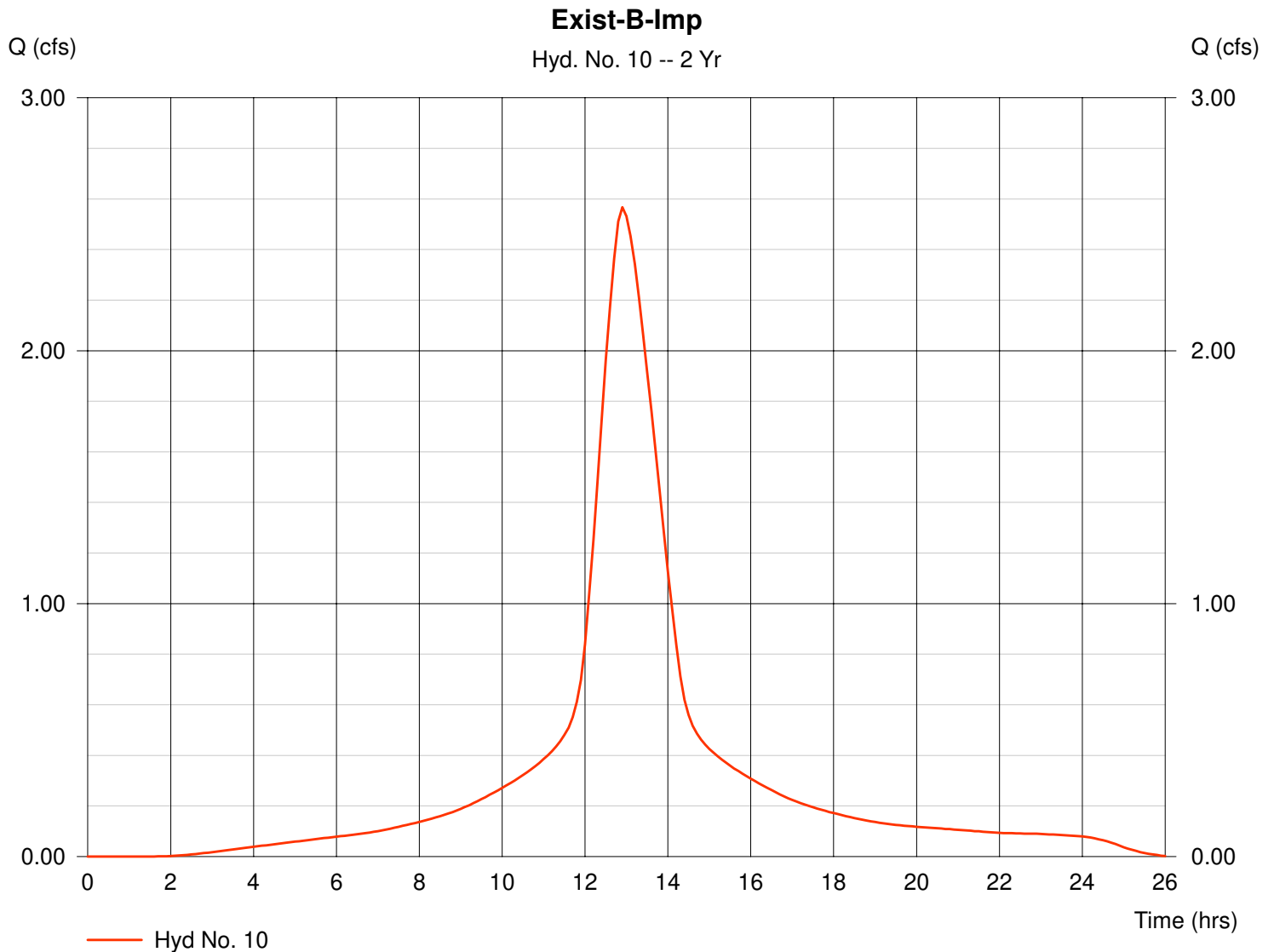

Hydrograph Plot

Hydraflow Hydrographs by Intelisolve

Tuesday, Feb 11 2020, 10:32 AM

Hyd. No. 11

Exist-B-Perv

Hydrograph type = SCS Runoff
Storm frequency = 2 yrs
Drainage area = 124.34 ac
Basin Slope = 0.0 %
Tc method = USER
Total precip. = 3.44 in
Storm duration = 24 hrs

Peak discharge = 0.00 cfs
Time interval = 6 min
Curve number = 30
Hydraulic length = 0 ft
Time of conc. (Tc) = 87.7 min
Distribution = Type III
Shape factor = 484

Hydrograph Volume = 0 cuft

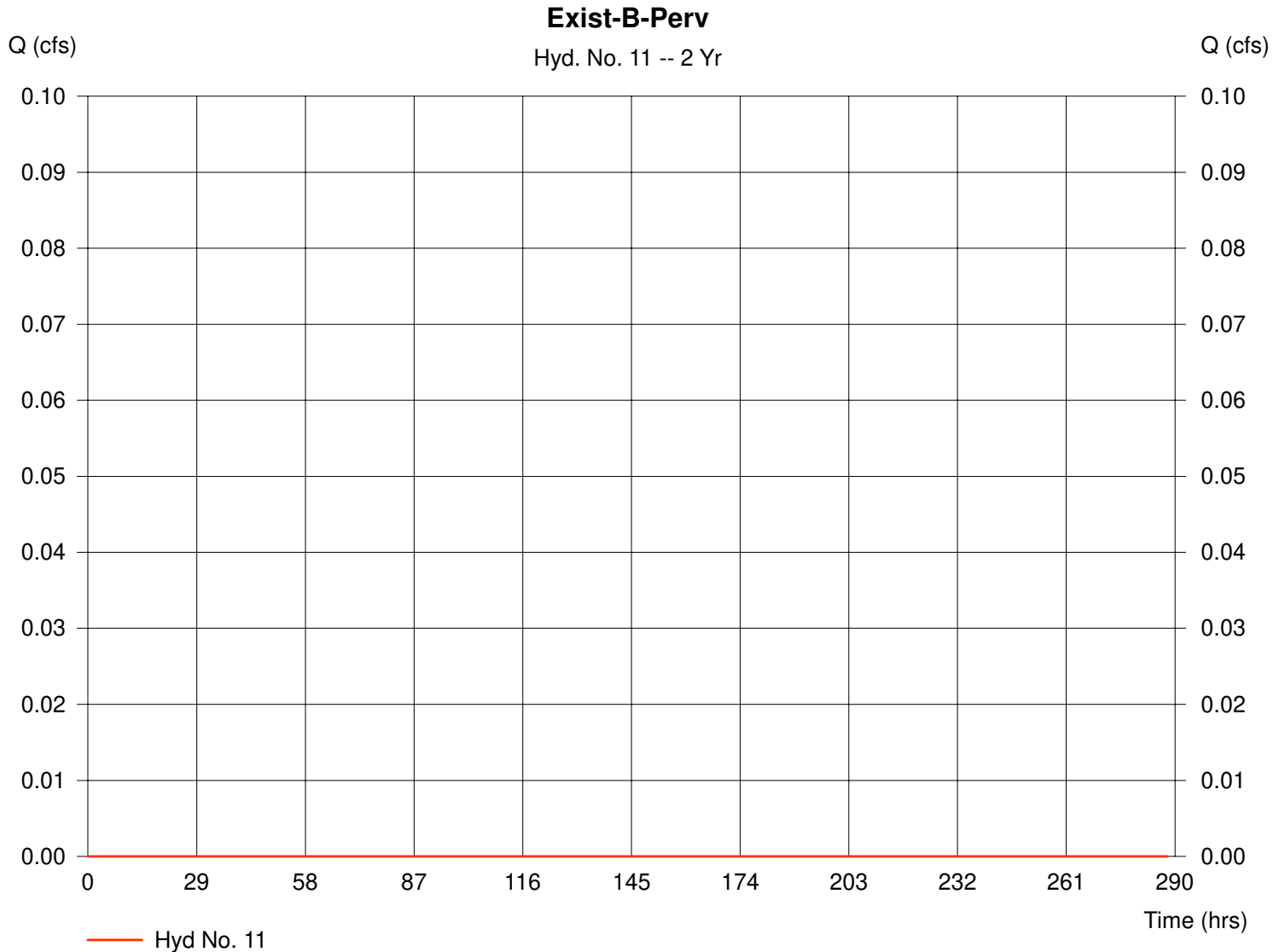

Hydrograph Plot

Hydraflow Hydrographs by Intelisolve

Tuesday, Feb 11 2020, 10:32 AM

Hyd. No. 12

Exist-B

Hydrograph type = Combine
Storm frequency = 2 yrs
Inflow hyds. = 10, 11

Peak discharge = 2.57 cfs
Time interval = 6 min

Hydrograph Volume = 27,238 cuft

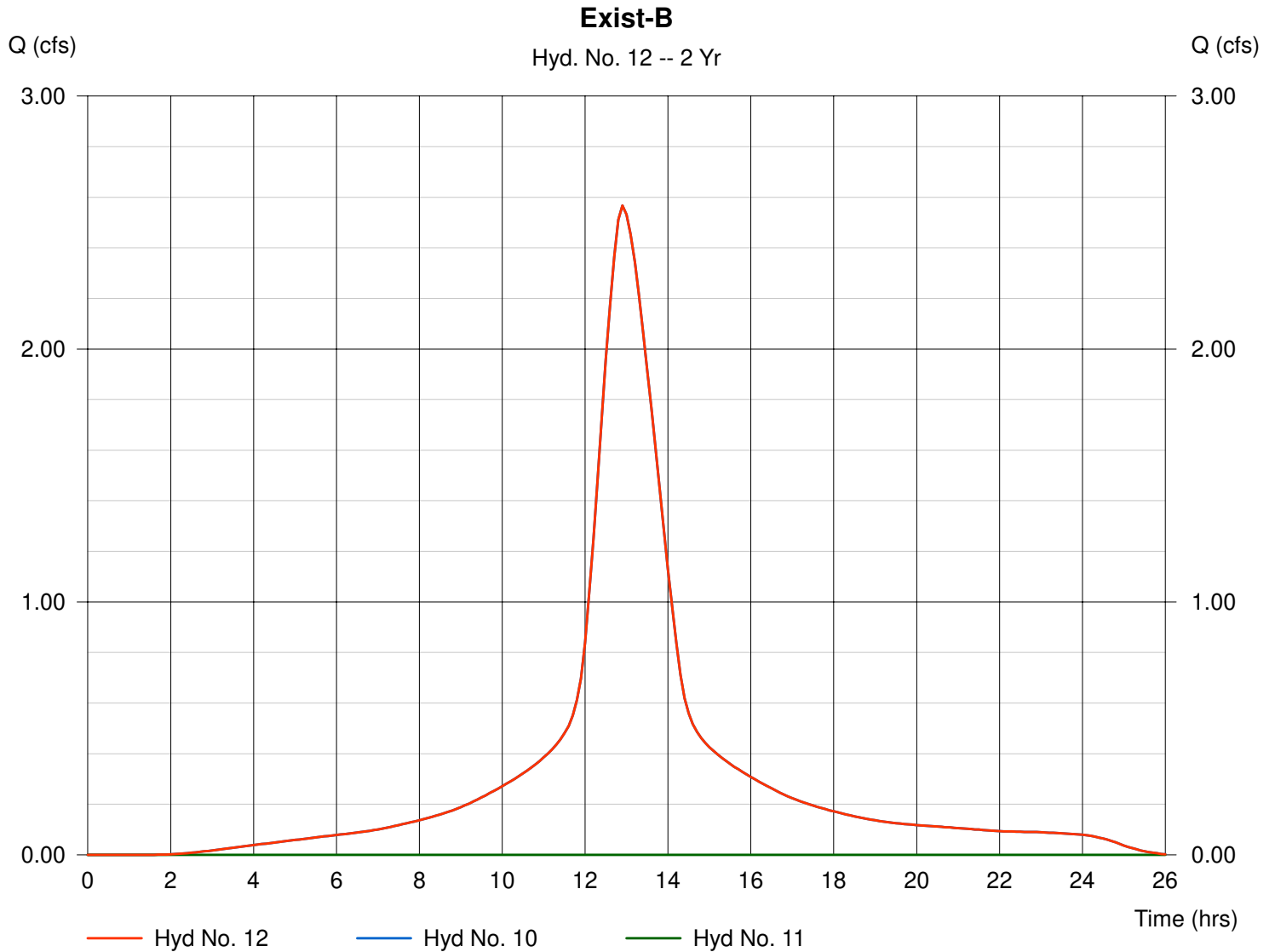

Hydrograph Plot

Hydraflow Hydrographs by Intelisolve

Tuesday, Feb 11 2020, 10:32 AM

Hyd. No. 14

Prop-B-Imp

Hydrograph type = SCS Runoff
Storm frequency = 2 yrs
Drainage area = 0.12 ac
Basin Slope = 0.0 %
Tc method = USER
Total precip. = 3.44 in
Storm duration = 24 hrs

Peak discharge = 0.13 cfs
Time interval = 6 min
Curve number = 98
Hydraulic length = 0 ft
Time of conc. (Tc) = 82.7 min
Distribution = Type III
Shape factor = 484

Hydrograph Volume = 1,397 cuft

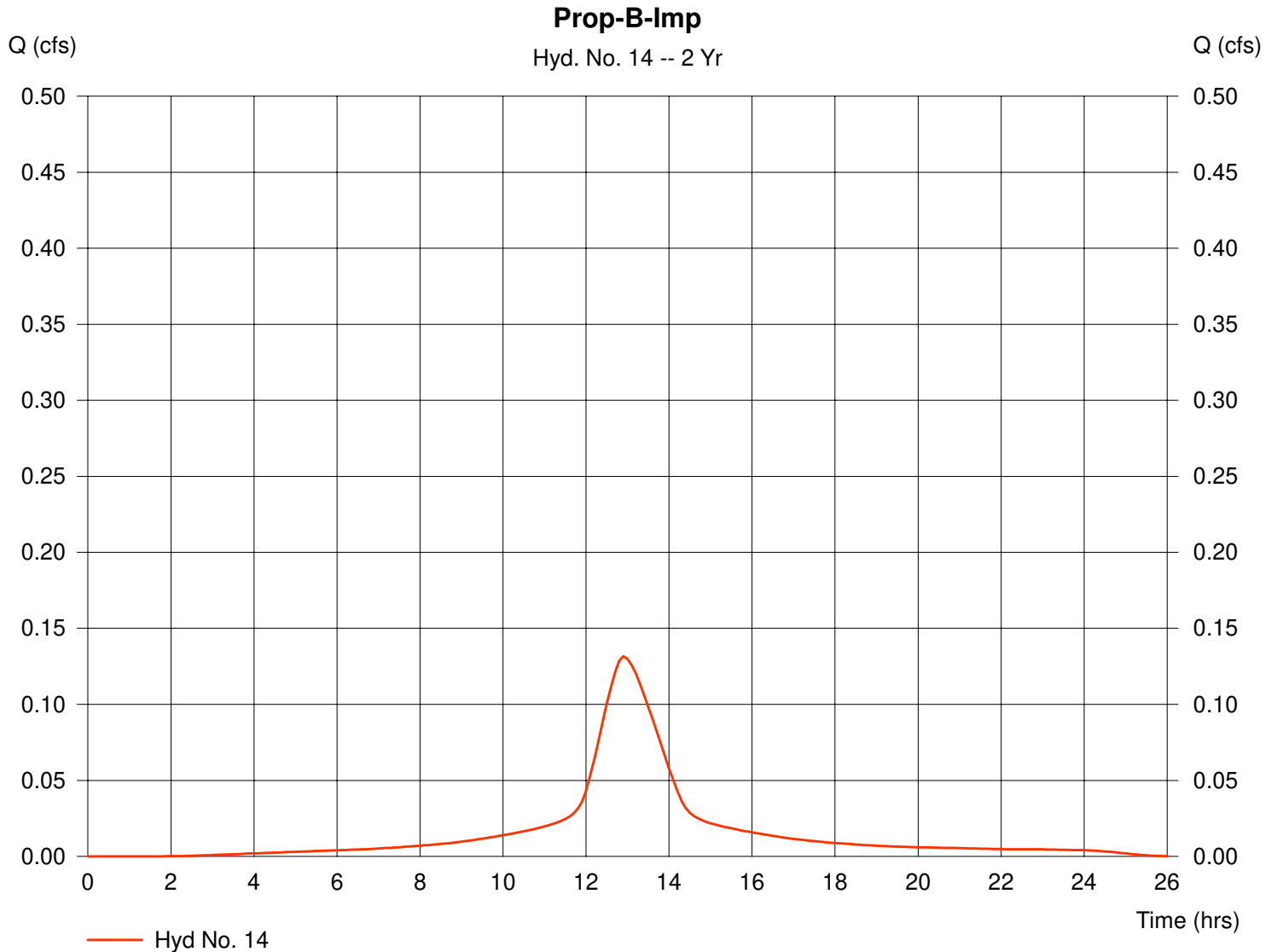

Hydrograph Plot

Hydraflow Hydrographs by Intelisolve

Tuesday, Feb 11 2020, 10:32 AM

Hyd. No. 15

Prop-B-Perv

Hydrograph type = SCS Runoff
Storm frequency = 2 yrs
Drainage area = 38.41 ac
Basin Slope = 0.0 %
Tc method = USER
Total precip. = 3.44 in
Storm duration = 24 hrs

Peak discharge = 0.00 cfs
Time interval = 6 min
Curve number = 31
Hydraulic length = 0 ft
Time of conc. (Tc) = 82.7 min
Distribution = Type III
Shape factor = 484

Hydrograph Volume = 0 cuft

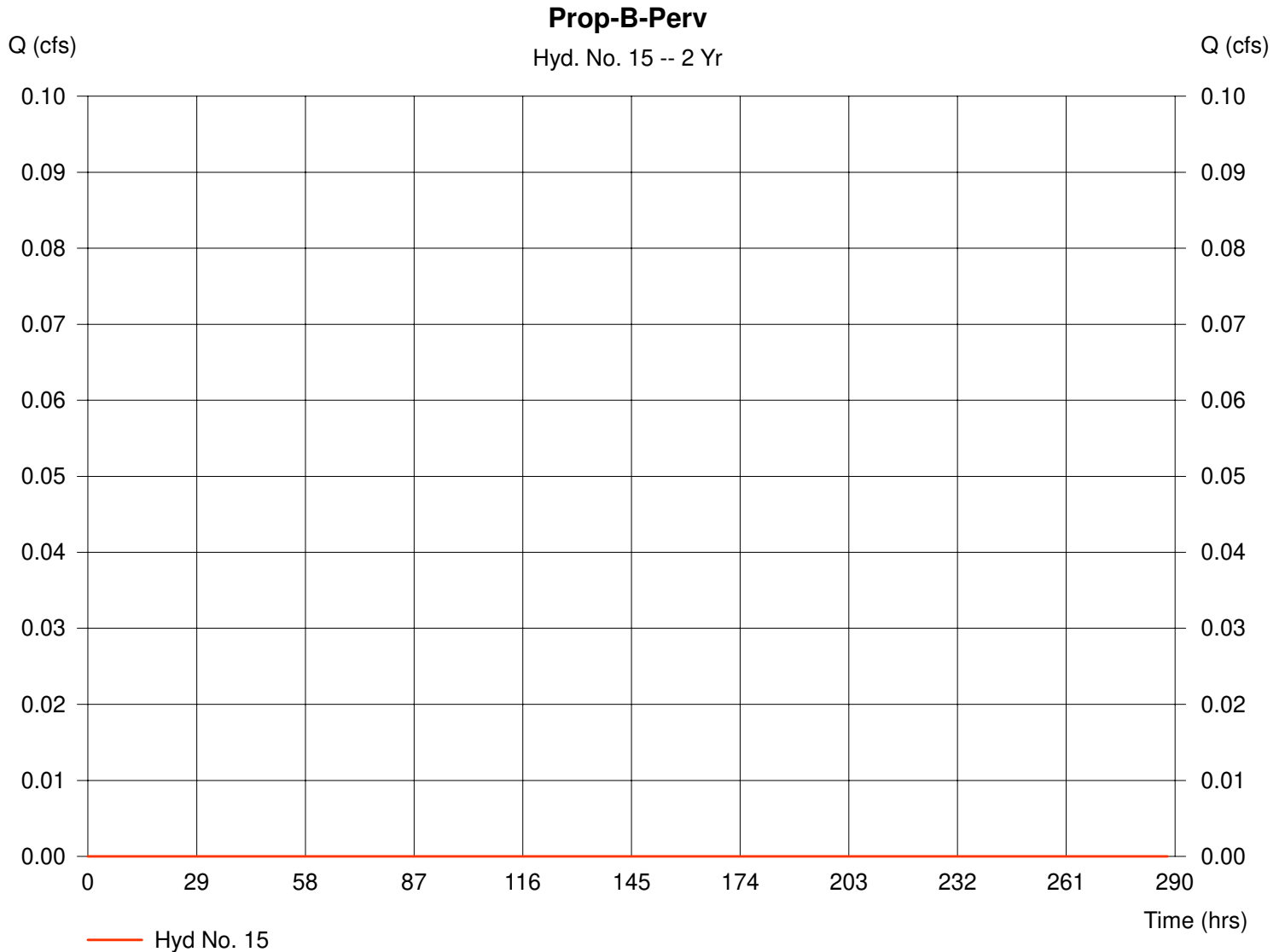

Hydrograph Plot

Hydraflow Hydrographs by Intelisolve

Tuesday, Feb 11 2020, 10:32 AM

Hyd. No. 17

Prop-B-Imp-FAN-Basin

Hydrograph type = SCS Runoff
Storm frequency = 2 yrs
Drainage area = 0.63 ac
Basin Slope = 0.0 %
Tc method = USER
Total precip. = 3.44 in
Storm duration = 24 hrs

Peak discharge = 0.69 cfs
Time interval = 6 min
Curve number = 98
Hydraulic length = 0 ft
Time of conc. (Tc) = 82.7 min
Distribution = Type III
Shape factor = 484

Hydrograph Volume = 7,287 cuft

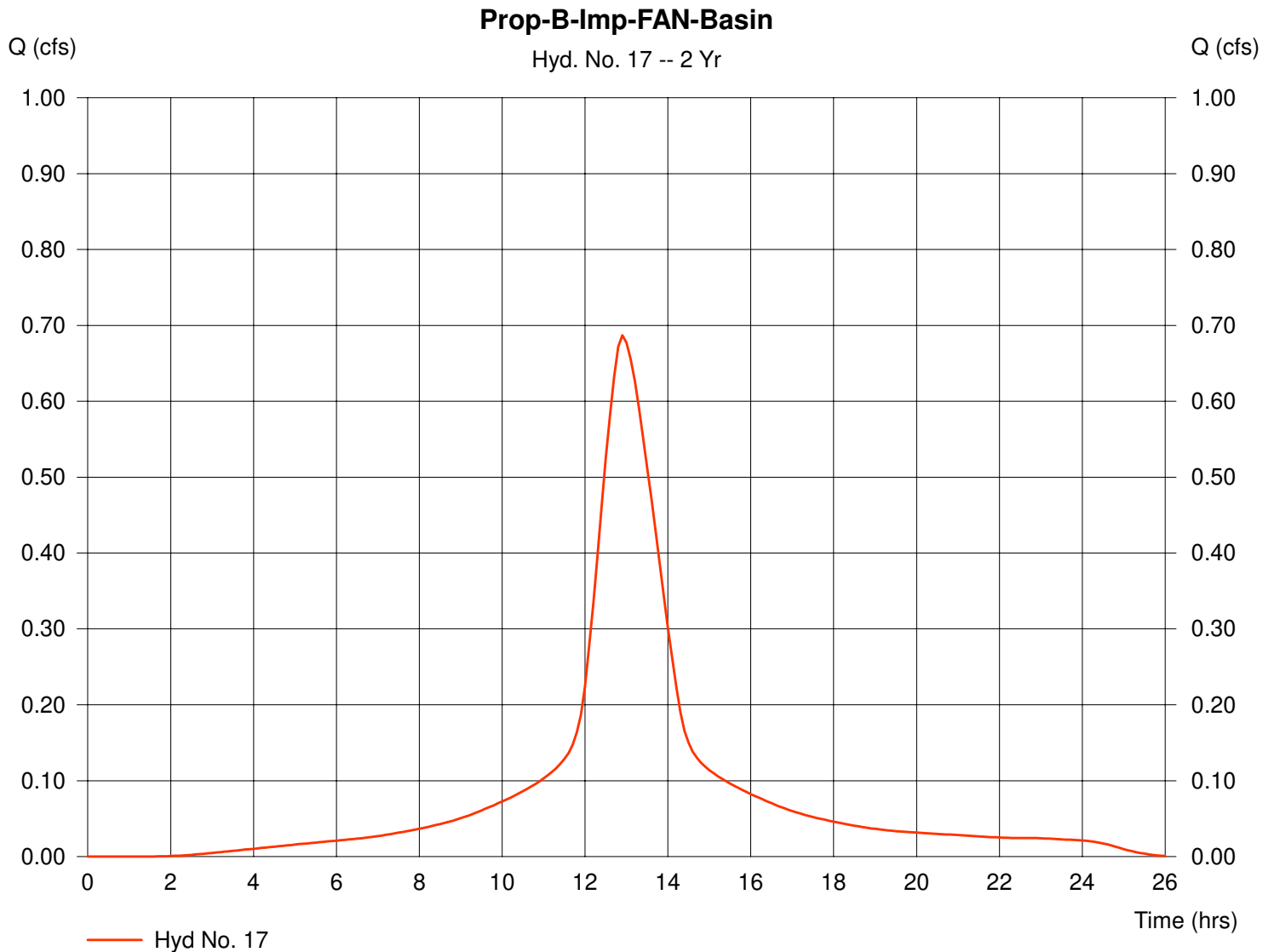

Hydrograph Plot

Hydraflow Hydrographs by Intelisolve

Tuesday, Feb 11 2020, 10:32 AM

Hyd. No. 18

Prop-B-Perv-FAN-Basin

Hydrograph type = SCS Runoff
Storm frequency = 2 yrs
Drainage area = 83.82 ac
Basin Slope = 0.0 %
Tc method = USER
Total precip. = 3.44 in
Storm duration = 24 hrs

Peak discharge = 0.00 cfs
Time interval = 6 min
Curve number = 32
Hydraulic length = 0 ft
Time of conc. (Tc) = 82.7 min
Distribution = Type III
Shape factor = 484

Hydrograph Volume = 0 cuft

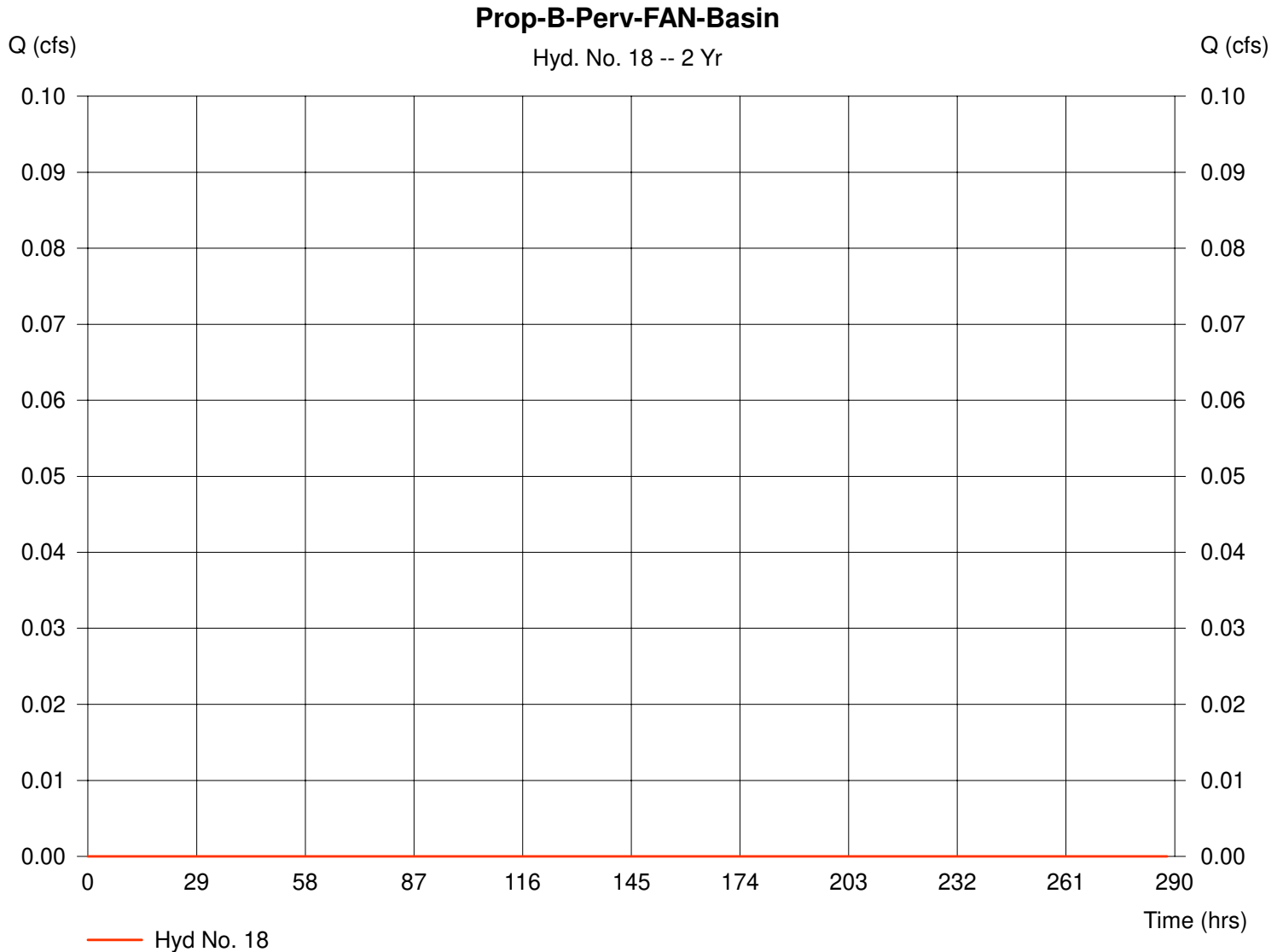

Hydrograph Plot

Hydraflow Hydrographs by Intelisolve

Tuesday, Feb 11 2020, 10:32 AM

Hyd. No. 19

FAN Basin Inflow

Hydrograph type = Combine
Storm frequency = 2 yrs
Inflow hyds. = 17, 18

Peak discharge = 0.69 cfs
Time interval = 6 min

Hydrograph Volume = 7,287 cuft

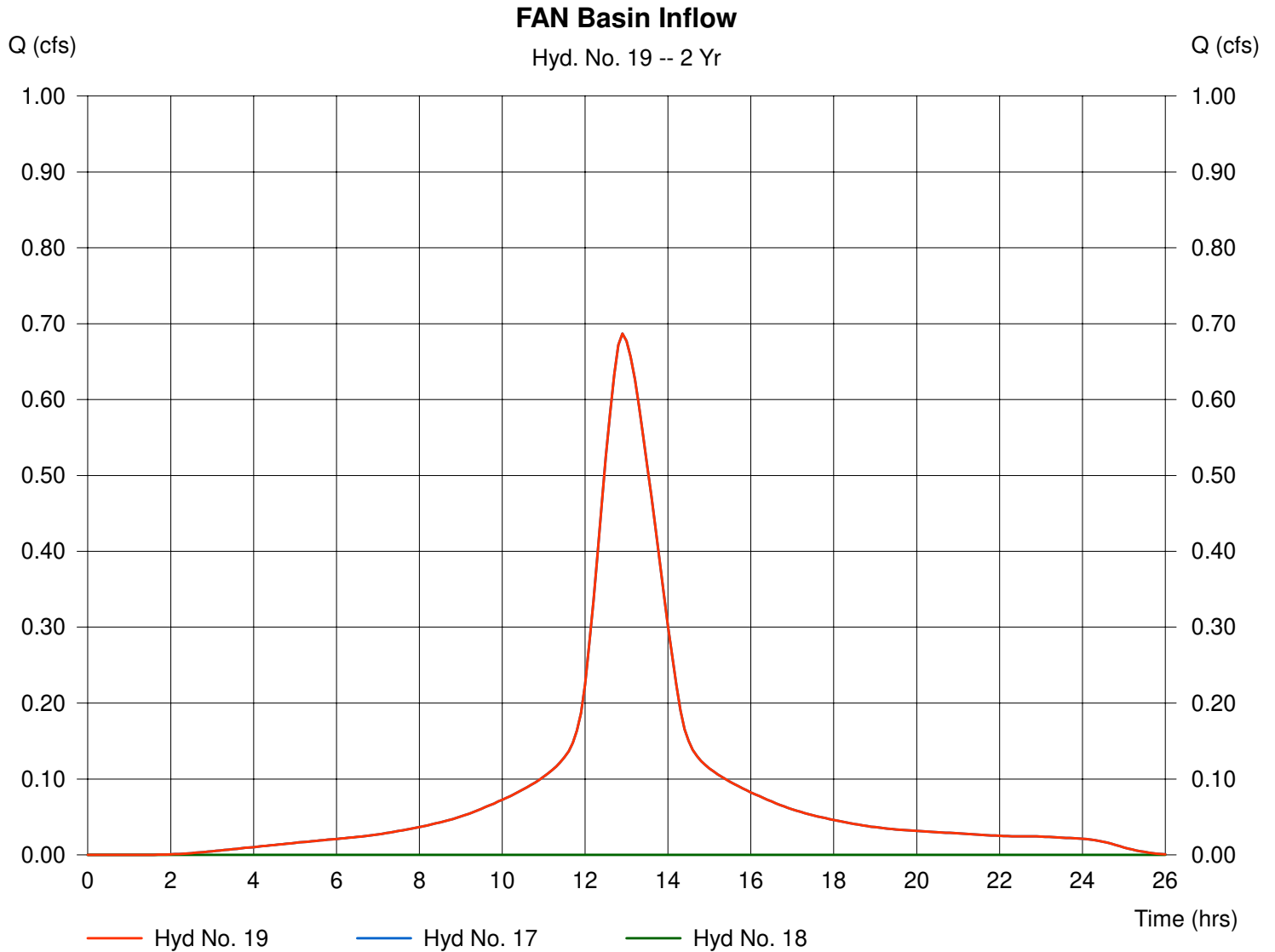

Hydrograph Plot

Hydraflow Hydrographs by Intelisolve

Tuesday, Feb 11 2020, 10:32 AM

Hyd. No. 20

FAN Basin 1 Routing

Hydrograph type = Reservoir
Storm frequency = 2 yrs
Inflow hyd. No. = 19
Reservoir name = FAN Basin

Peak discharge = 0.02 cfs
Time interval = 6 min
Max. Elevation = 154.43 ft
Max. Storage = 6,547 cuft

Storage Indication method used.

Hydrograph Volume = 4,150 cuft

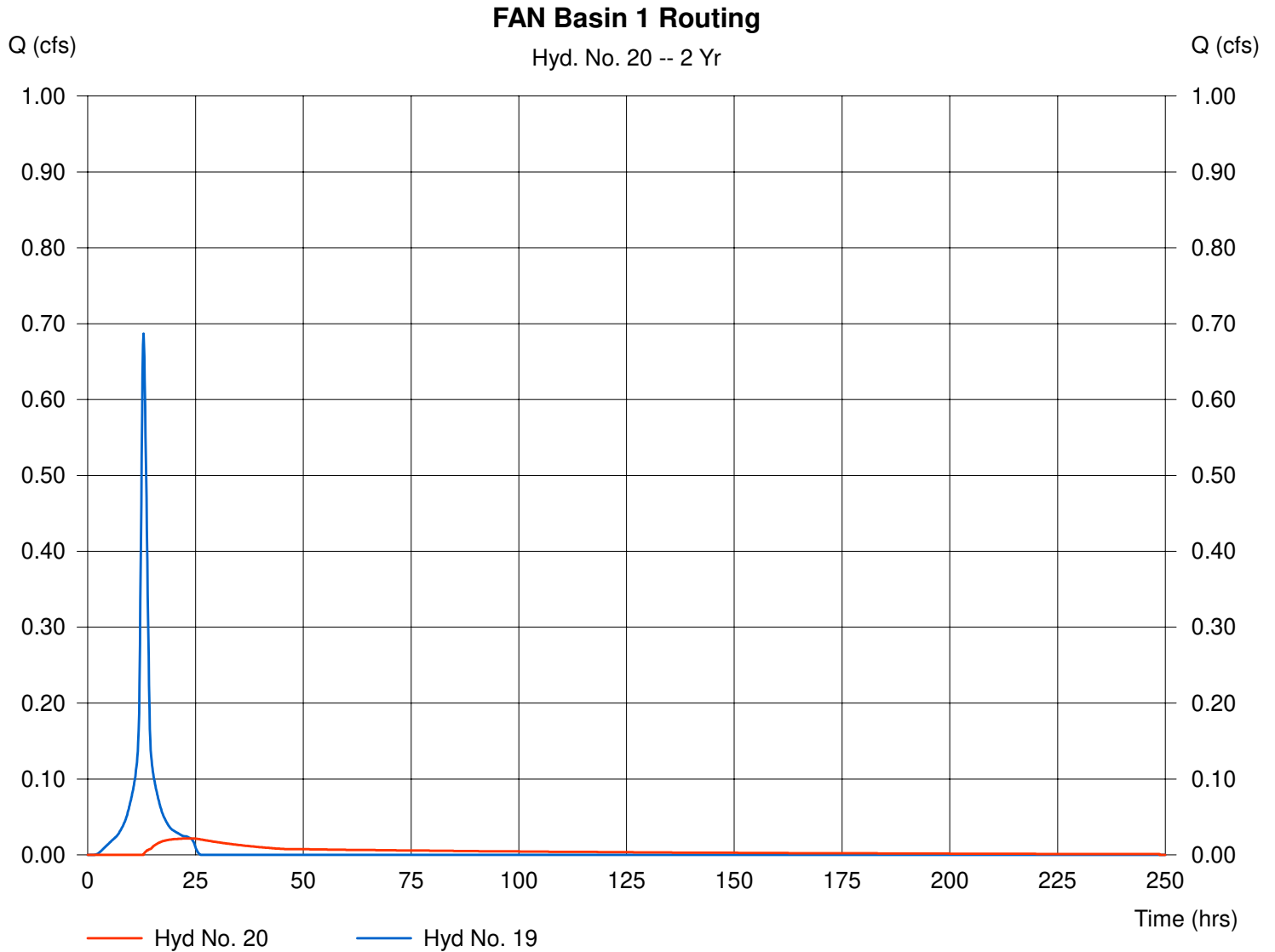

Pond Report

Hydraflow Hydrographs by Intelisolve

Tuesday, Feb 11 2020, 10:32 AM

Pond No. 1 - FAN Basin

Pond Data

Pond storage is based on known contour areas. Average end area method used.

Stage / Storage Table

Stage (ft)	Elevation (ft)	Contour area (sqft)	Incr. Storage (cuft)	Total storage (cuft)
0.00	154.25	36,091	0	0
0.75	155.00	38,058	27,806	27,806
1.75	156.00	40,796	39,427	67,233
2.75	157.00	43,656	42,226	109,459

Culvert / Orifice Structures

	[A]	[B]	[C]	[D]
Rise (in)	= 18.00	6.00	0.00	0.00
Span (in)	= 18.00	6.00	0.00	0.00
No. Barrels	= 1	1	0	0
Invert El. (ft)	= 154.25	154.35	0.00	0.00
Length (ft)	= 38.00	0.00	0.00	0.00
Slope (%)	= 3.30	0.00	0.00	0.00
N-Value	= .013	.013	.013	.000
Orif. Coeff.	= 0.60	0.60	0.60	0.00
Multi-Stage	= n/a	Yes	No	No

Weir Structures

	[A]	[B]	[C]	[D]
Crest Len (ft)	= 16.00	2.00	0.00	0.00
Crest El. (ft)	= 156.50	156.00	0.00	0.00
Weir Coeff.	= 3.33	3.33	3.33	0.00
Weir Type	= Riser	Rect	---	---
Multi-Stage	= Yes	Yes	No	No

Exfiltration = 0.000 in/hr (Contour) Tailwater Elev. = 0.00 ft

Note: Culvert/Orifice outflows have been analyzed under inlet and outlet control.

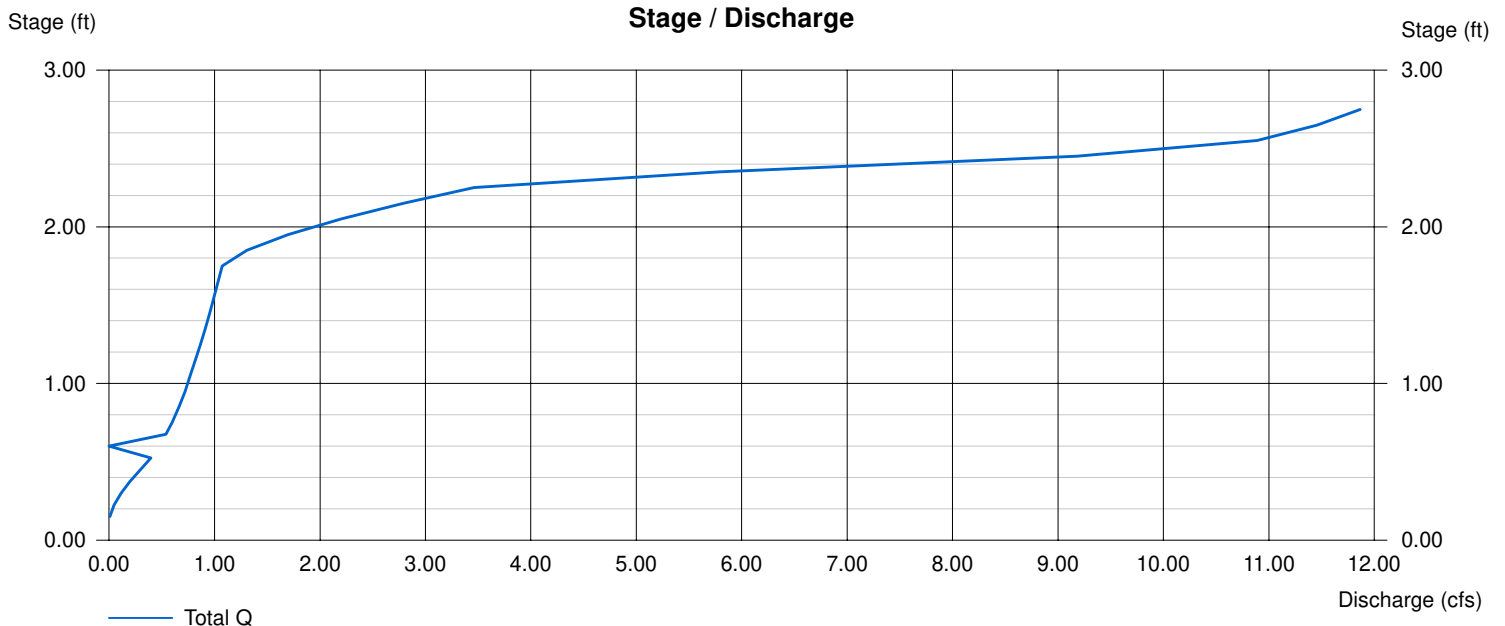

Hydrograph Plot

Hydraflow Hydrographs by Intelisolve

Tuesday, Feb 11 2020, 10:32 AM

Hyd. No. 21

Prop-B-Imp-ROCA-Basin

Hydrograph type = SCS Runoff
Storm frequency = 2 yrs
Drainage area = 0.20 ac
Basin Slope = 0.0 %
Tc method = USER
Total precip. = 3.44 in
Storm duration = 24 hrs

Peak discharge = 0.22 cfs
Time interval = 6 min
Curve number = 98
Hydraulic length = 0 ft
Time of conc. (Tc) = 82.7 min
Distribution = Type III
Shape factor = 484

Hydrograph Volume = 2,328 cuft

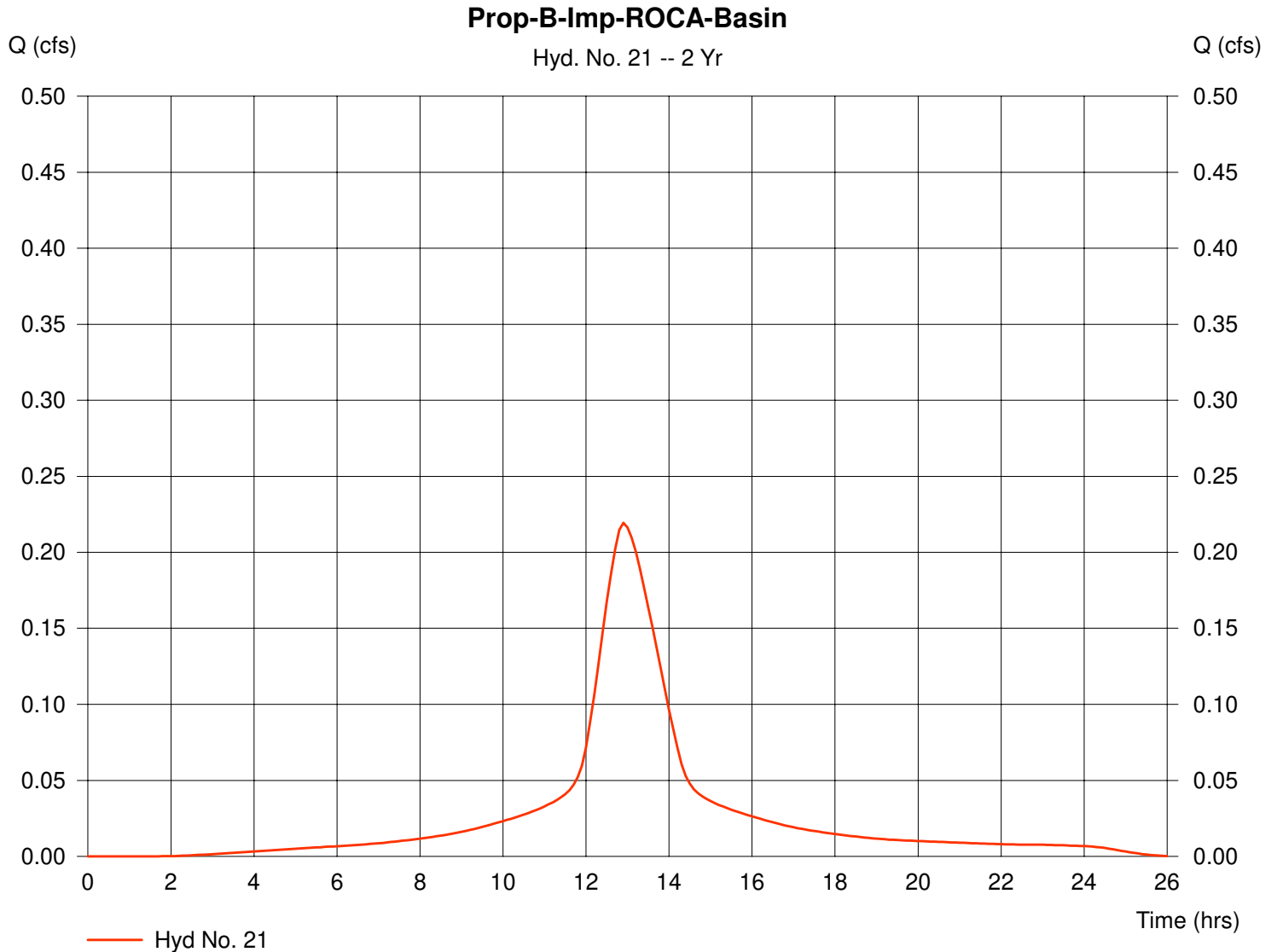

Hydrograph Plot

Hydraflow Hydrographs by Intelisolve

Tuesday, Feb 11 2020, 10:32 AM

Hyd. No. 22

Prop-B-Perv-ROCA-Basin

Hydrograph type = SCS Runoff
Storm frequency = 2 yrs
Drainage area = 10.79 ac
Basin Slope = 0.0 %
Tc method = USER
Total precip. = 3.44 in
Storm duration = 24 hrs

Peak discharge = 0.01 cfs
Time interval = 6 min
Curve number = 38
Hydraulic length = 0 ft
Time of conc. (Tc) = 82.7 min
Distribution = Type III
Shape factor = 484

Hydrograph Volume = 74 cuft

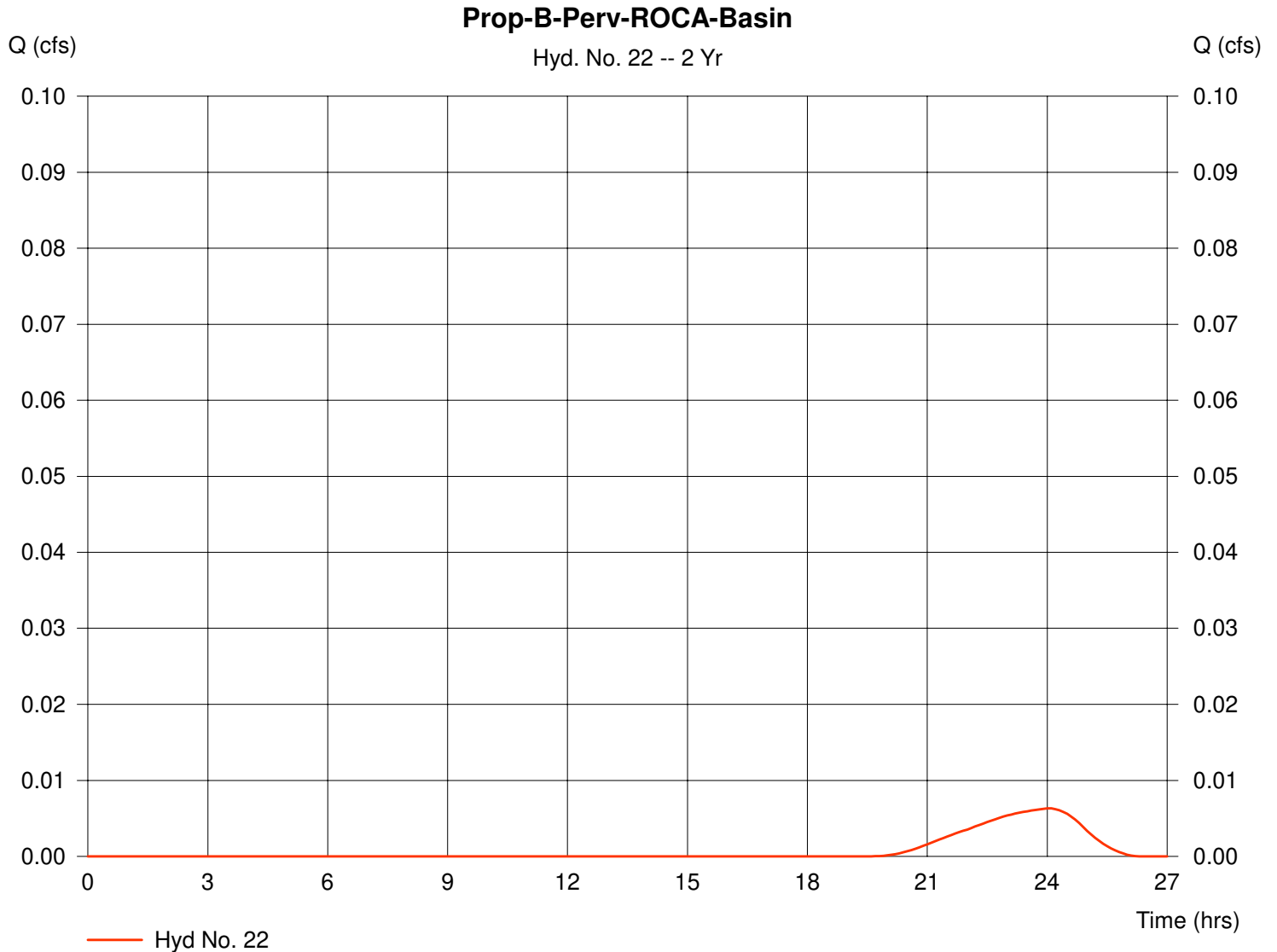

Hydrograph Plot

Hydraflow Hydrographs by Intelisolve

Tuesday, Feb 11 2020, 10:32 AM

Hyd. No. 23

ROCA Basin Inflow

Hydrograph type = Combine
Storm frequency = 2 yrs
Inflow hyds. = 21, 22

Peak discharge = 0.22 cfs
Time interval = 6 min

Hydrograph Volume = 2,402 cuft

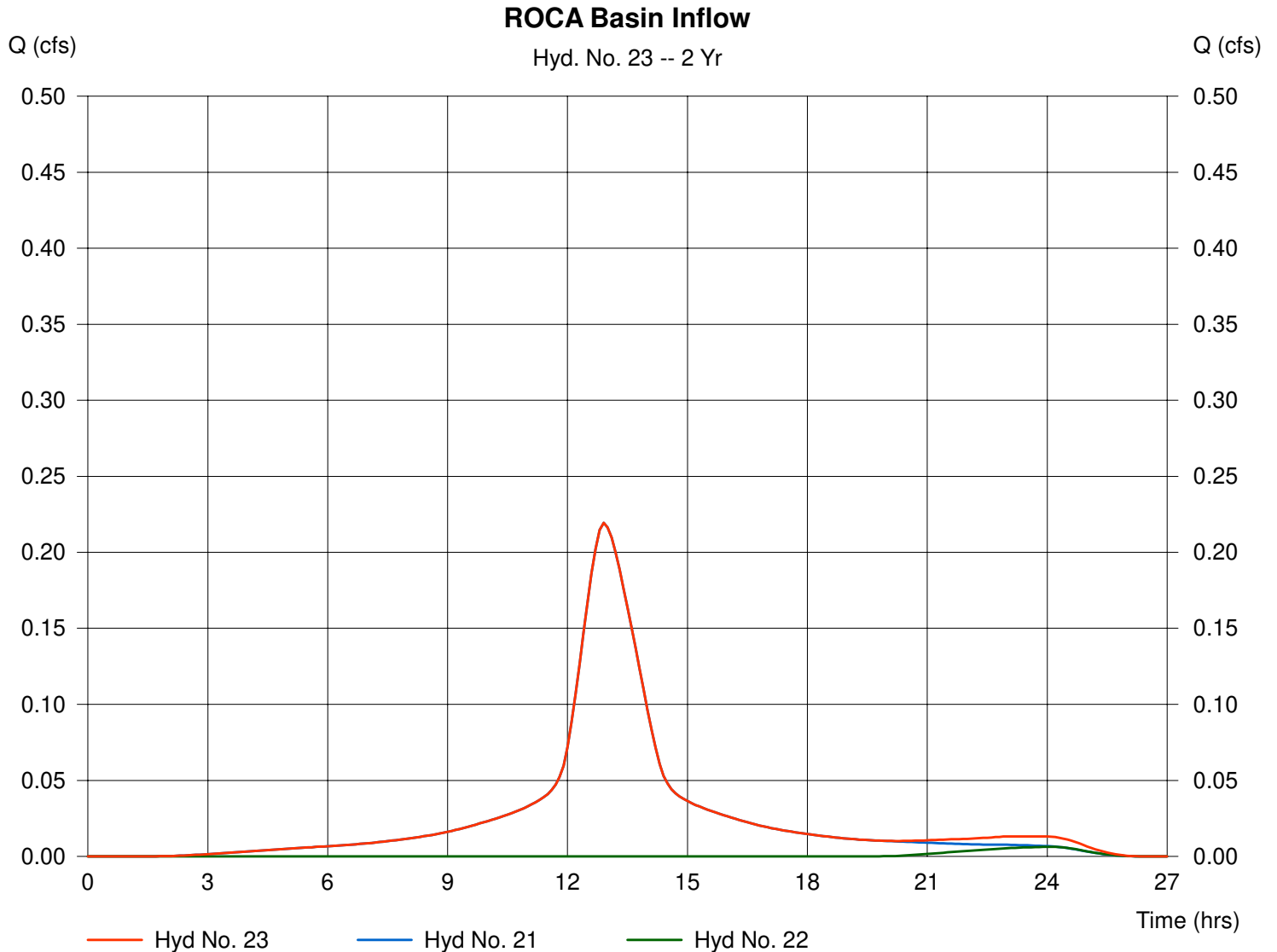

Hydrograph Plot

Hydraflow Hydrographs by Intelisolve

Tuesday, Feb 11 2020, 10:32 AM

Hyd. No. 24

ROCA Basin Routing

Hydrograph type = Reservoir
Storm frequency = 2 yrs
Inflow hyd. No. = 23
Reservoir name = ROCA Basin

Peak discharge = 0.02 cfs
Time interval = 6 min
Max. Elevation = 154.67 ft
Max. Storage = 1,840 cuft

Storage Indication method used.

Hydrograph Volume = 1,275 cuft

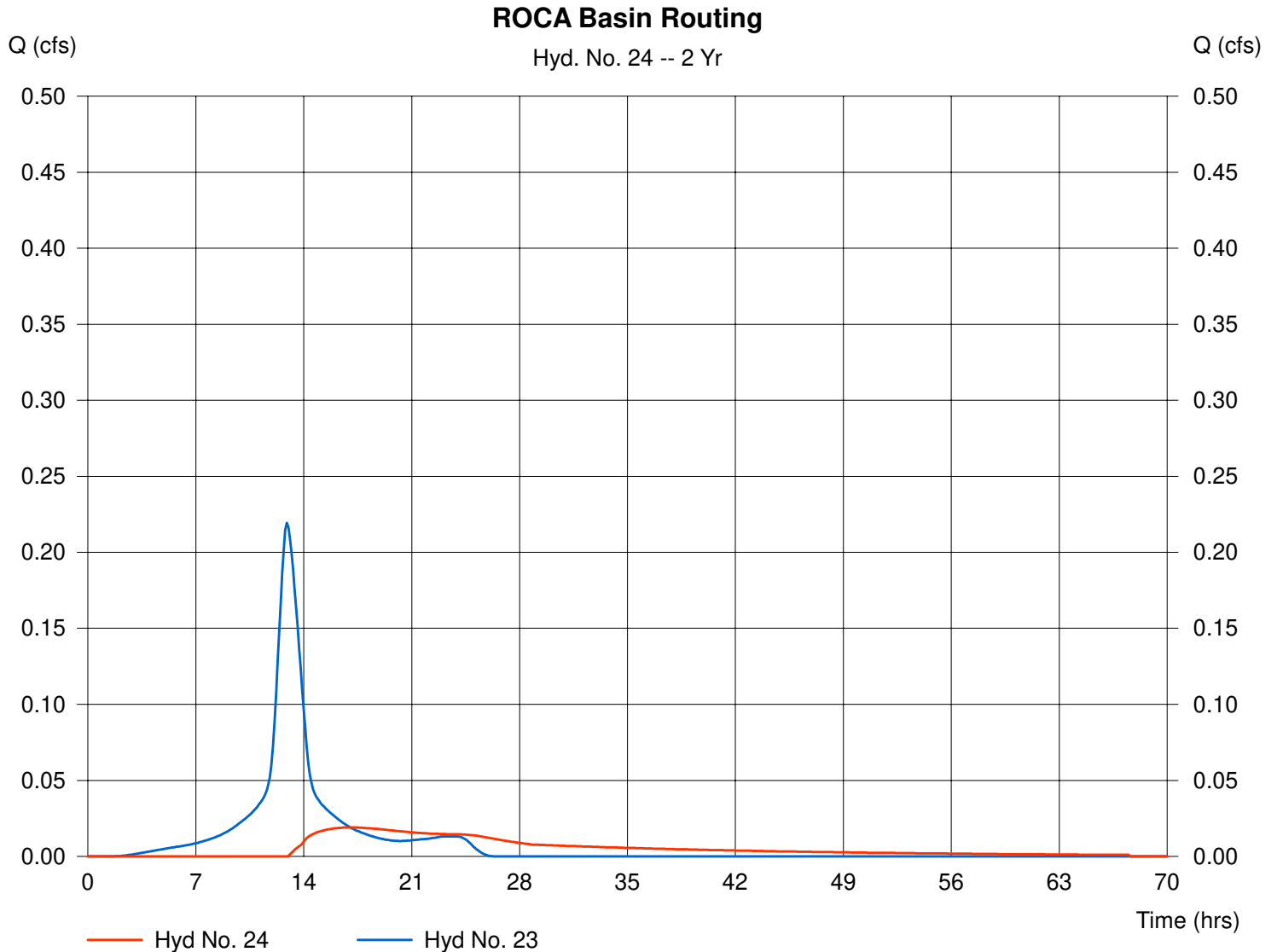

Pond Report

Hydraflow Hydrographs by Intelisolve

Tuesday, Feb 11 2020, 10:32 AM

Pond No. 2 - ROCA Basin

Pond Data

Pond storage is based on known contour areas. Average end area method used.

Stage / Storage Table

Stage (ft)	Elevation (ft)	Contour area (sqft)	Incr. Storage (cuft)	Total storage (cuft)
0.00	154.50	10,126	0	0
0.50	155.00	11,053	5,295	5,295
1.50	156.00	13,036	12,045	17,339
2.00	156.50	14,055	6,773	24,112

Culvert / Orifice Structures

	[A]	[B]	[C]	[D]
Rise (in)	= 18.00	6.00	0.00	0.00
Span (in)	= 18.00	6.00	0.00	0.00
No. Barrels	= 1	1	0	0
Invert El. (ft)	= 154.50	154.60	0.00	0.00
Length (ft)	= 115.00	0.00	0.00	0.00
Slope (%)	= 1.30	0.00	0.00	0.00
N-Value	= .013	.013	.000	.000
Orif. Coeff.	= 0.60	0.60	0.00	0.00
Multi-Stage	= n/a	Yes	No	No

Weir Structures

	[A]	[B]	[C]	[D]
Crest Len (ft)	= 16.00	0.00	0.00	0.00
Crest El. (ft)	= 156.50	0.00	0.00	0.00
Weir Coeff.	= 3.33	3.33	0.00	0.00
Weir Type	= Riser	---	---	---
Multi-Stage	= Yes	No	No	No

Exfiltration = 0.000 in/hr (Contour) Tailwater Elev. = 0.00 ft

Note: Culvert/Orifice outflows have been analyzed under inlet and outlet control.

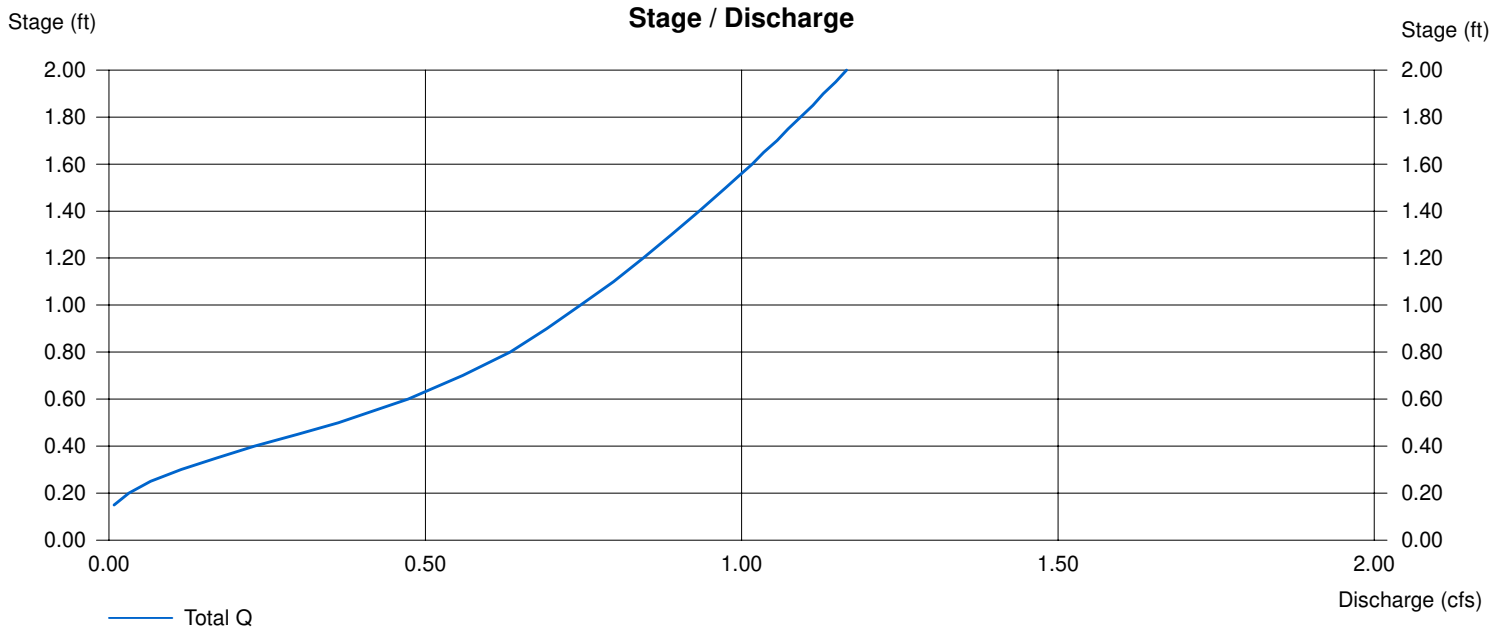

Hydrograph Plot

Hydraflow Hydrographs by Intelisolve

Tuesday, Feb 11 2020, 10:32 AM

Hyd. No. 25

Prop-B

Hydrograph type = Combine
Storm frequency = 2 yrs
Inflow hyds. = 14, 15

Peak discharge = 0.13 cfs
Time interval = 6 min

Hydrograph Volume = 1,397 cuft

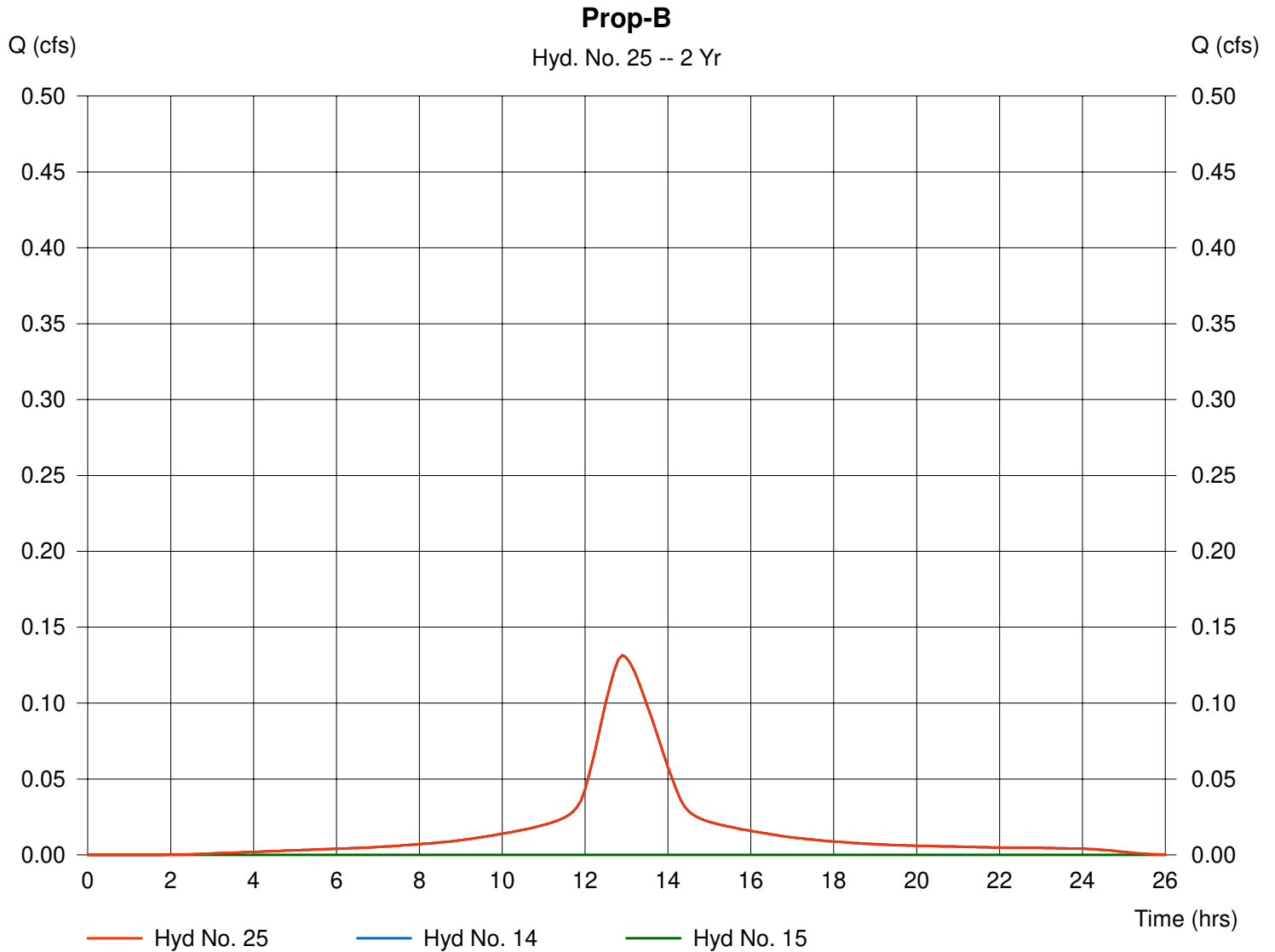

Hydrograph Plot

Hydraflow Hydrographs by Intelisolve

Tuesday, Feb 11 2020, 10:32 AM

Hyd. No. 26

Prop-B

Hydrograph type = Combine
Storm frequency = 2 yrs
Inflow hyds. = 20, 24, 25

Peak discharge = 0.13 cfs
Time interval = 6 min

Hydrograph Volume = 6,822 cuft

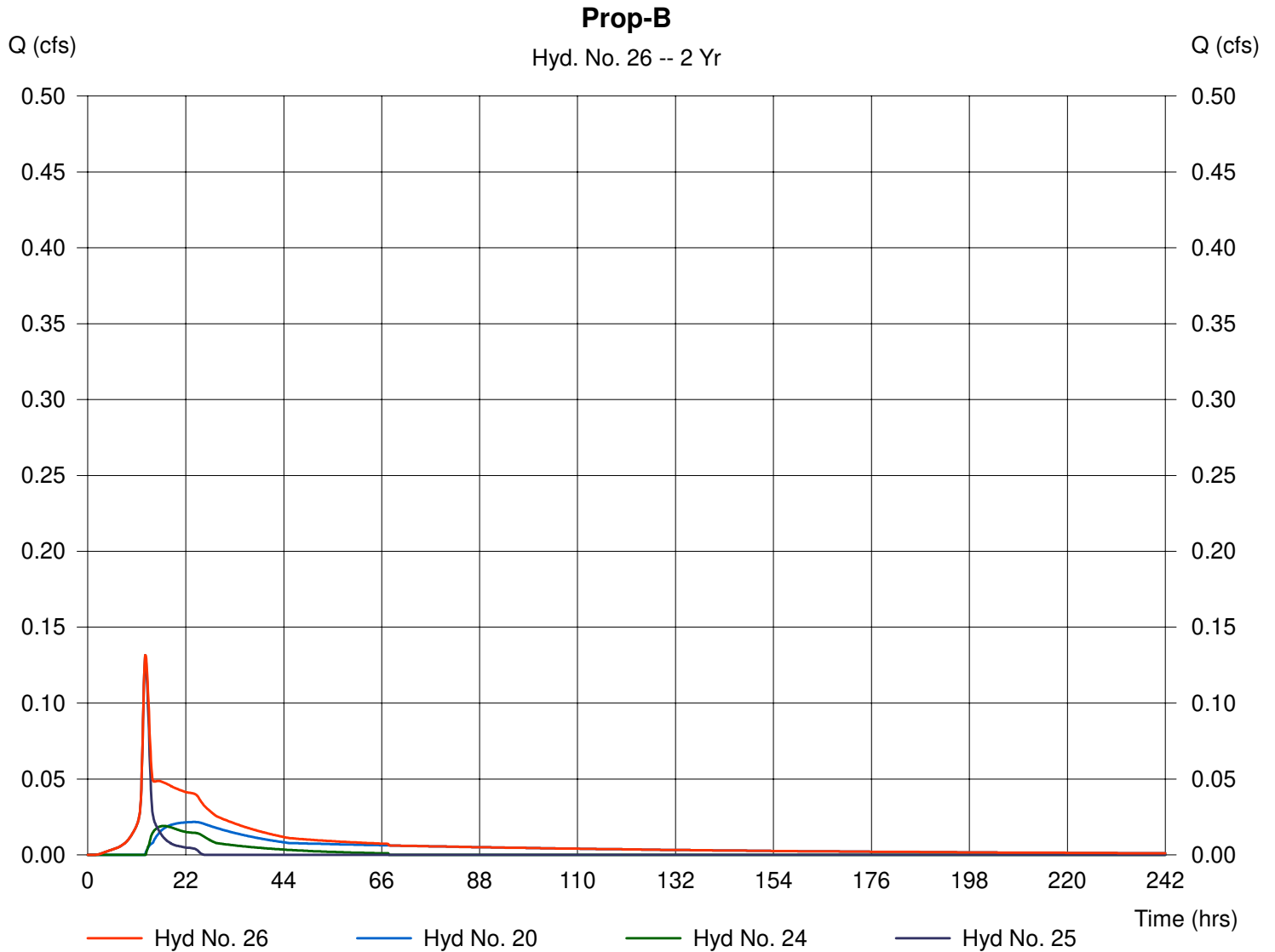

Hydrograph Plot

Hydraflow Hydrographs by Intelisolve

Tuesday, Feb 11 2020, 10:32 AM

Hyd. No. 29

Exist-C-Imp

Hydrograph type = SCS Runoff
Storm frequency = 2 yrs
Drainage area = 1.66 ac
Basin Slope = 0.0 %
Tc method = USER
Total precip. = 3.44 in
Storm duration = 24 hrs

Peak discharge = 1.95 cfs
Time interval = 6 min
Curve number = 98
Hydraulic length = 0 ft
Time of conc. (Tc) = 76.33 min
Distribution = Type III
Shape factor = 484

Hydrograph Volume = 19,021 cuft

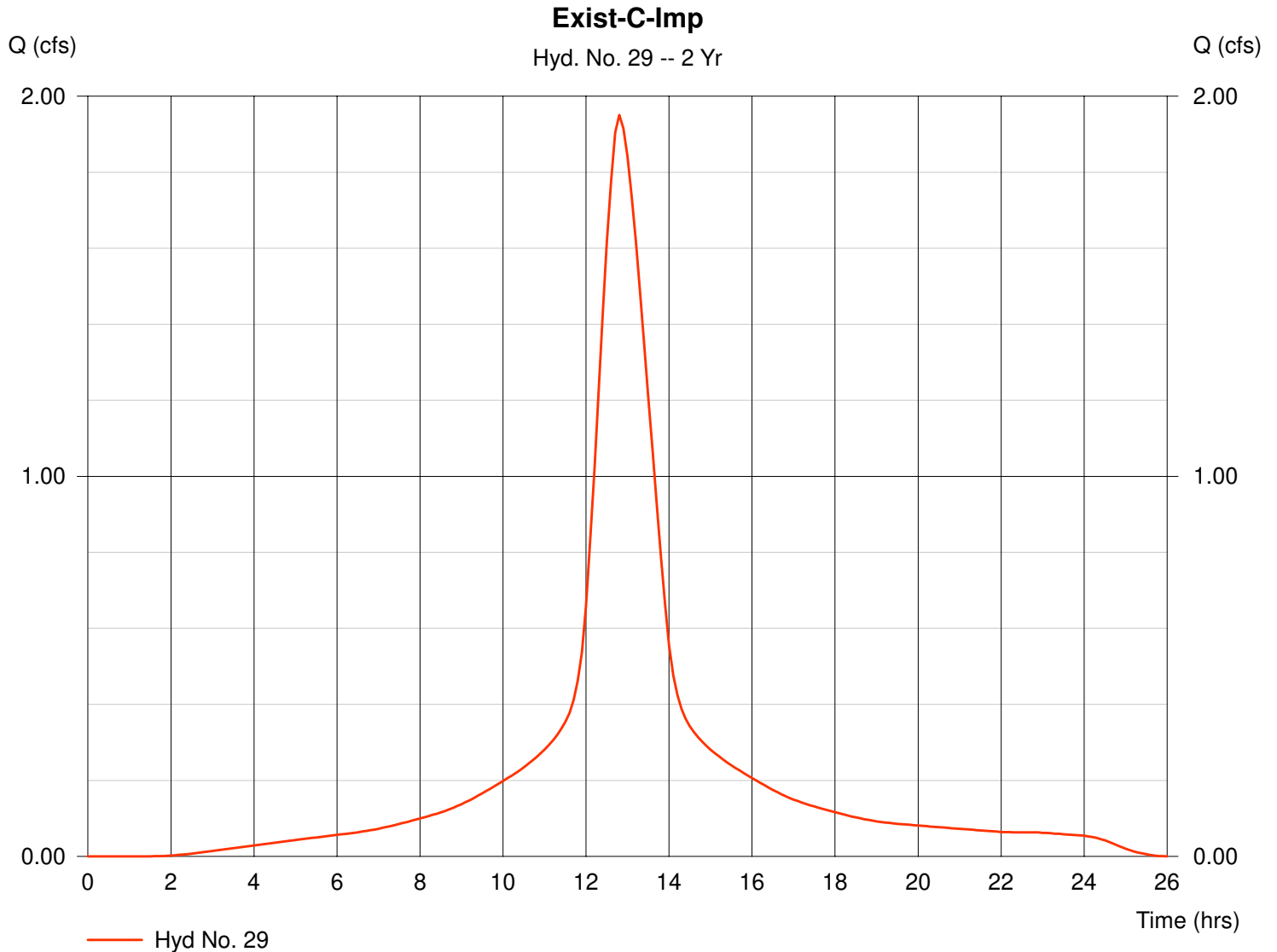

Hydrograph Plot

Hydraflow Hydrographs by Intelisolve

Tuesday, Feb 11 2020, 10:32 AM

Hyd. No. 30

Exist-C-Perv

Hydrograph type = SCS Runoff
 Storm frequency = 2 yrs
 Drainage area = 130.63 ac
 Basin Slope = 0.0 %
 Tc method = USER
 Total precip. = 3.44 in
 Storm duration = 24 hrs

Peak discharge = 0.24 cfs
 Time interval = 6 min
 Curve number = 40
 Hydraulic length = 0 ft
 Time of conc. (Tc) = 76.33 min
 Distribution = Type III
 Shape factor = 484

Hydrograph Volume = 5,853 cuft

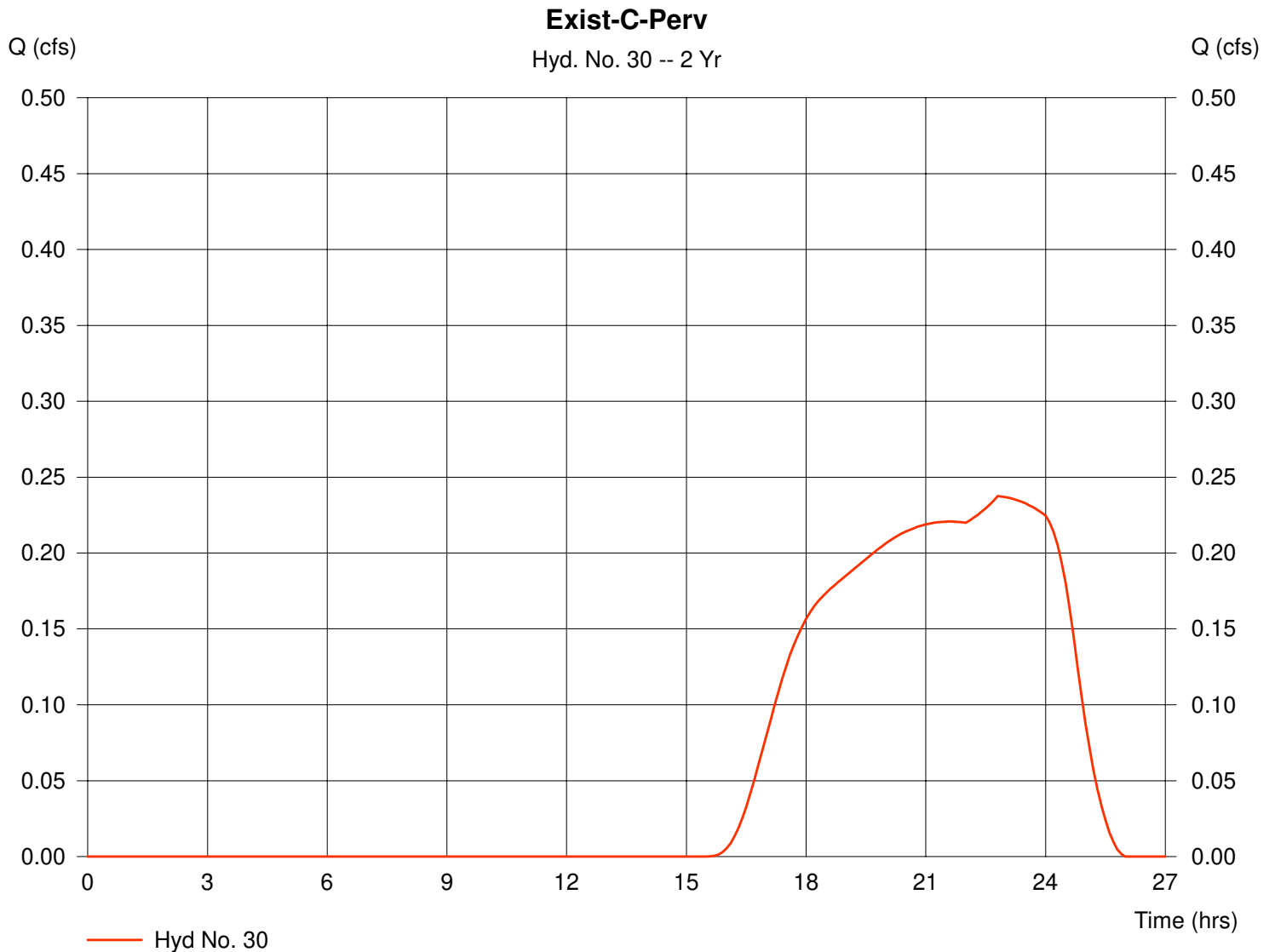

Hydrograph Plot

Hydraflow Hydrographs by Intelisolve

Tuesday, Feb 11 2020, 10:32 AM

Hyd. No. 31

Exist-C

Hydrograph type = Combine
Storm frequency = 2 yrs
Inflow hyds. = 29, 30

Peak discharge = 1.95 cfs
Time interval = 6 min

Hydrograph Volume = 24,874 cuft

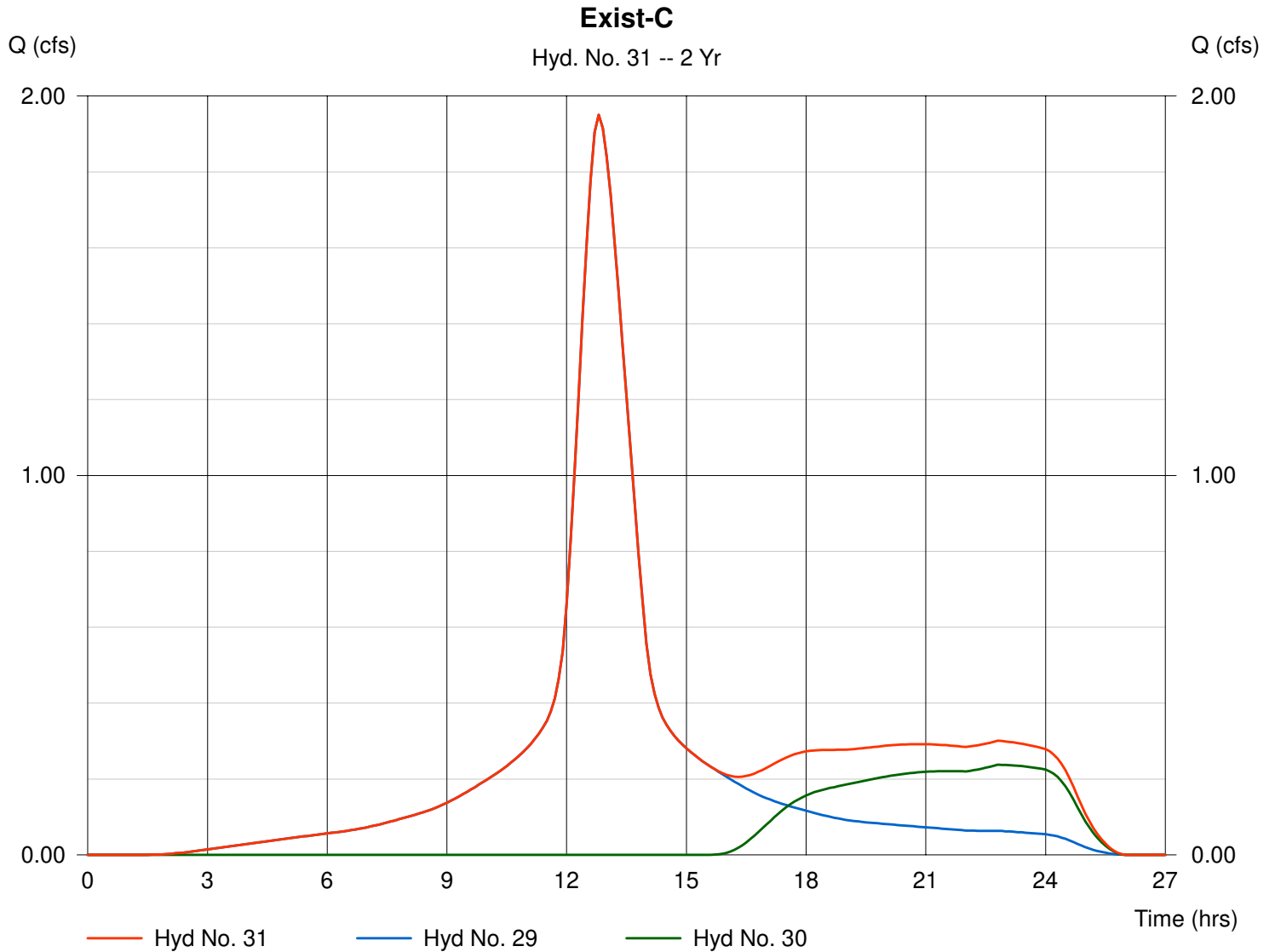

Hydrograph Plot

Hydraflow Hydrographs by Intelisolve

Tuesday, Feb 11 2020, 10:32 AM

Hyd. No. 33

Prop-C-Imp

Hydrograph type = SCS Runoff
Storm frequency = 2 yrs
Drainage area = 1.42 ac
Basin Slope = 0.0 %
Tc method = USER
Total precip. = 3.44 in
Storm duration = 24 hrs

Peak discharge = 1.67 cfs
Time interval = 6 min
Curve number = 98
Hydraulic length = 0 ft
Time of conc. (Tc) = 75.49 min
Distribution = Type III
Shape factor = 484

Hydrograph Volume = 16,271 cuft

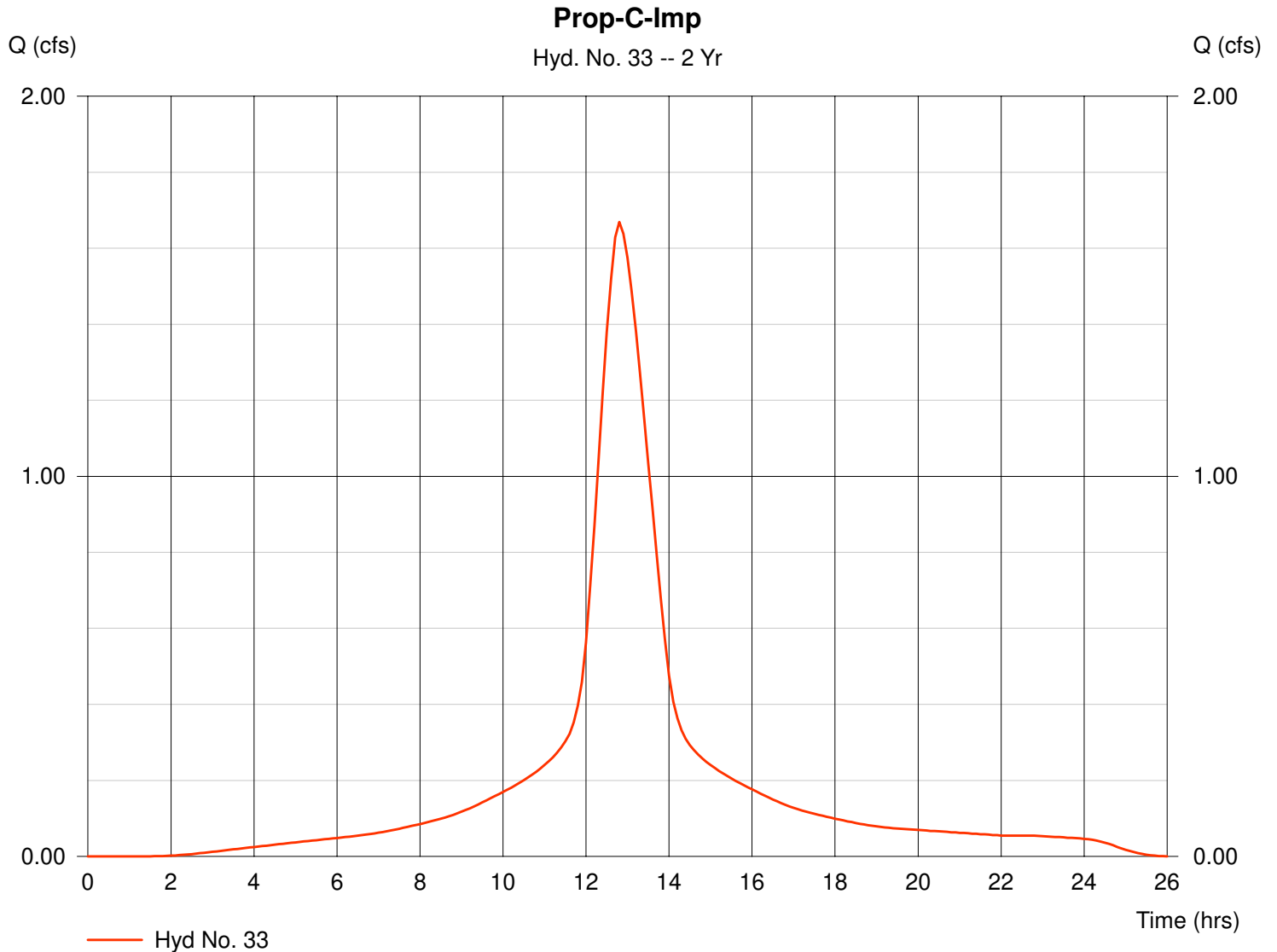

Hydrograph Plot

Hydraflow Hydrographs by Intelisolve

Tuesday, Feb 11 2020, 10:32 AM

Hyd. No. 34

Prop-C-Perv

Hydrograph type = SCS Runoff
Storm frequency = 2 yrs
Drainage area = 133.04 ac
Basin Slope = 0.0 %
Tc method = USER
Total precip. = 3.44 in
Storm duration = 24 hrs

Peak discharge = 0.24 cfs
Time interval = 6 min
Curve number = 40
Hydraulic length = 0 ft
Time of conc. (Tc) = 75.49 min
Distribution = Type III
Shape factor = 484

Hydrograph Volume = 5,961 cuft

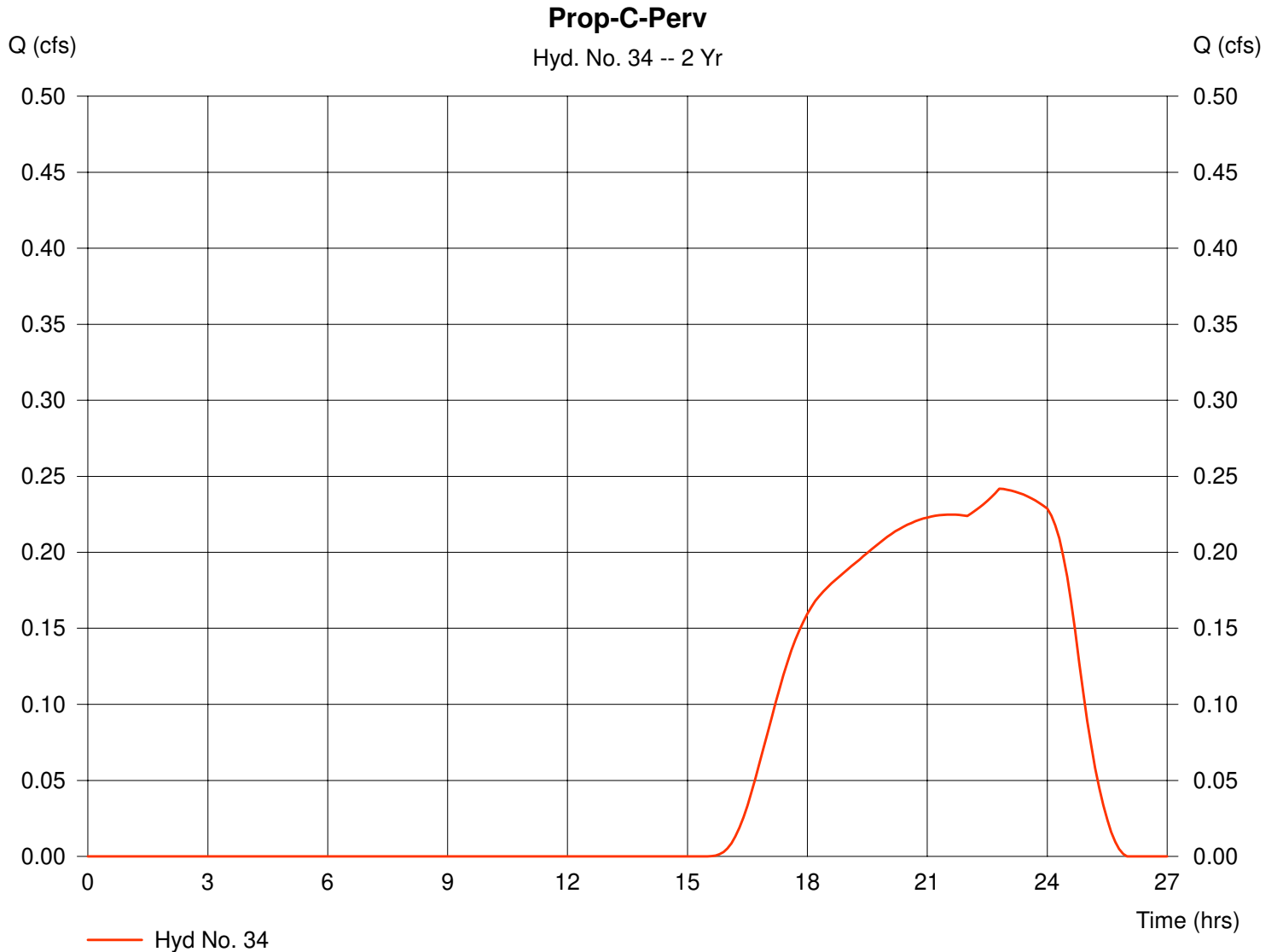

Hydrograph Plot

Hydraflow Hydrographs by Intelisolve

Tuesday, Feb 11 2020, 10:32 AM

Hyd. No. 35

Prop-C

Hydrograph type = Combine
Storm frequency = 2 yrs
Inflow hyds. = 33, 34

Peak discharge = 1.67 cfs
Time interval = 6 min

Hydrograph Volume = 22,232 cuft

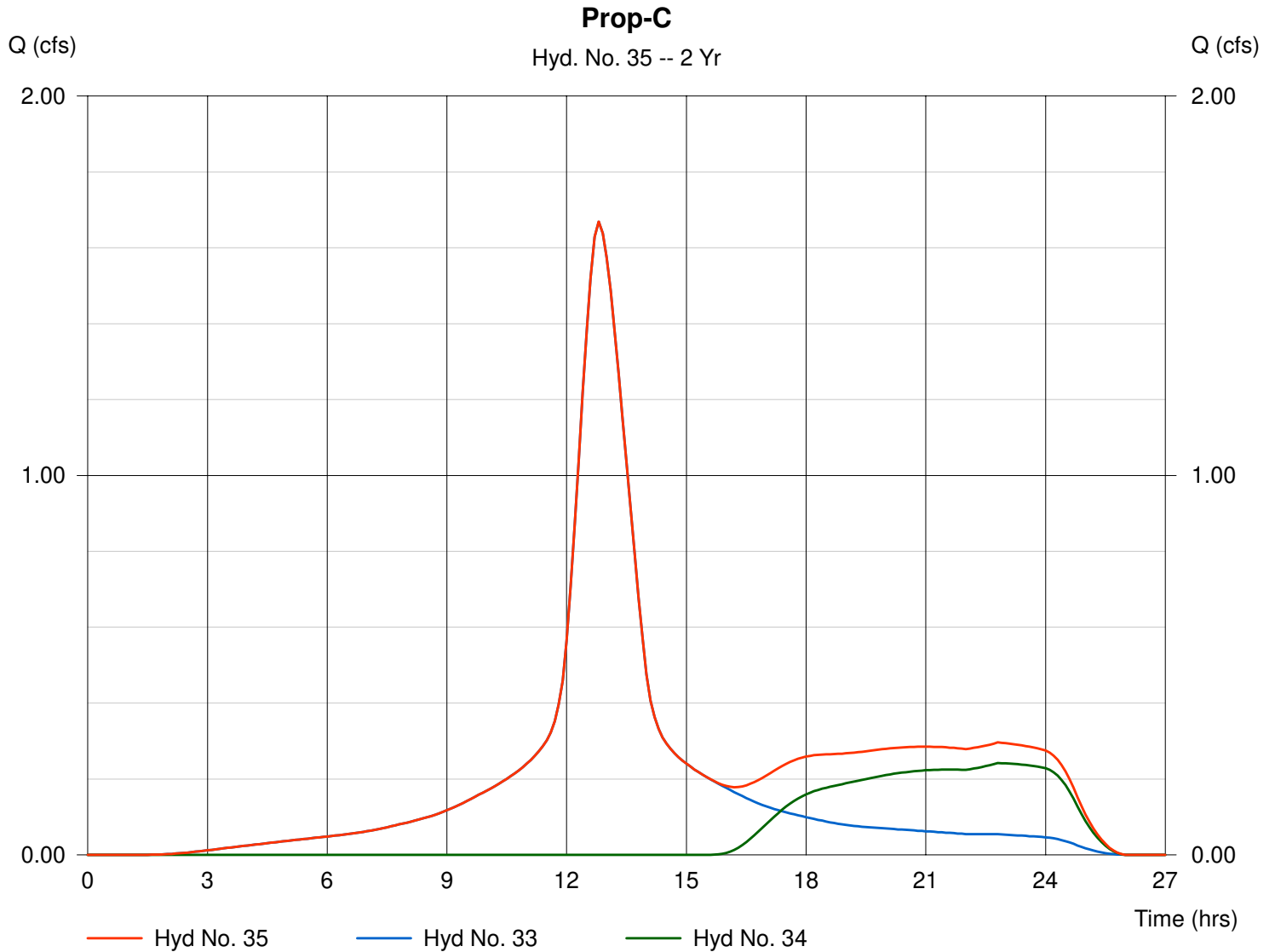

Hydrograph Summary Report

Hyd. No.	Hydrograph type (origin)	Peak flow (cfs)	Time interval (min)	Time to peak (min)	Volume (cuft)	Inflow hyd(s)	Maximum elevation (ft)	Maximum storage (cuft)	Hydrograph description
1	SCS Runoff	3.42	6	780	39,437	---	-----	-----	Exist-A-Imp
2	SCS Runoff	1.30	6	966	37,154	---	-----	-----	Exist-A-Perv
3	Combine	3.42	6	780	76,591	1, 2	-----	-----	Exist-A
5	SCS Runoff	3.29	6	774	35,262	---	-----	-----	Prop-A-Imp
6	SCS Runoff	1.55	6	936	43,133	---	-----	-----	Prop-A-Perv
7	Combine	3.35	6	774	78,394	5, 6	-----	-----	Prop-A
10	SCS Runoff	3.23	6	774	34,524	---	-----	-----	Exist-B-Imp
11	SCS Runoff	0.00	6	0	0	---	-----	-----	Exist-B-Perv
12	Combine	3.23	6	774	34,524	10, 11	-----	-----	Exist-B
14	SCS Runoff	0.17	6	774	1,770	---	-----	-----	Prop-B-Imp
15	SCS Runoff	0.00	6	0	0	---	-----	-----	Prop-B-Perv
17	SCS Runoff	0.86	6	774	9,236	---	-----	-----	Prop-B-Imp-FAN-Basin
18	SCS Runoff	0.01	6	1476	36	---	-----	-----	Prop-B-Perv-FAN-Basin
19	Combine	0.86	6	774	9,272	17, 18	-----	-----	FAN Basin Inflow
20	Reservoir	0.04	6	1194	6,134	19	154.46	7,855	FAN Basin 1 Routing
21	SCS Runoff	0.28	6	774	2,951	---	-----	-----	Prop-B-Imp-ROCA-Basin
22	SCS Runoff	0.08	6	984	2,426	---	-----	-----	Prop-B-Perv-ROCA-Basin
23	Combine	0.28	6	774	5,377	21, 22	-----	-----	ROCA Basin Inflow
24	Reservoir	0.08	6	1146	4,250	23	154.76	2,790	ROCA Basin Routing
25	Combine	0.17	6	774	1,770	14, 15,	-----	-----	Prop-B
26	Combine	0.17	6	774	12,155	20, 24, 25	-----	-----	Prop-B
29	SCS Runoff	2.45	6	768	24,109	---	-----	-----	Exist-C-Imp
30	SCS Runoff	1.75	6	930	48,385	---	-----	-----	Exist-C-Perv
31	Combine	2.49	6	768	72,494	29, 30	-----	-----	Exist-C

Hydrograph Summary Report

Hyd. No.	Hydrograph type (origin)	Peak flow (cfs)	Time interval (min)	Time to peak (min)	Volume (cuft)	Inflow hyd(s)	Maximum elevation (ft)	Maximum storage (cuft)	Hydrograph description
33	SCS Runoff	2.10	6	768	20,623	---	-----	-----	Prop-C-Imp
34	SCS Runoff	1.78	6	930	49,278	---	-----	-----	Prop-C-Perv
35	Combine	2.14	6	768	69,901	33, 34	-----	-----	Prop-C

Hydrograph Plot

Hydraflow Hydrographs by Intelisolve

Tuesday, Feb 11 2020, 10:32 AM

Hyd. No. 1

Exist-A-Imp

Hydrograph type = SCS Runoff
Storm frequency = 5 yrs
Drainage area = 2.64 ac
Basin Slope = 0.0 %
Tc method = USER
Total precip. = 4.30 in
Storm duration = 24 hrs

Peak discharge = 3.42 cfs
Time interval = 6 min
Curve number = 98
Hydraulic length = 0 ft
Time of conc. (Tc) = 91.29 min
Distribution = Type III
Shape factor = 484

Hydrograph Volume = 39,437 cuft

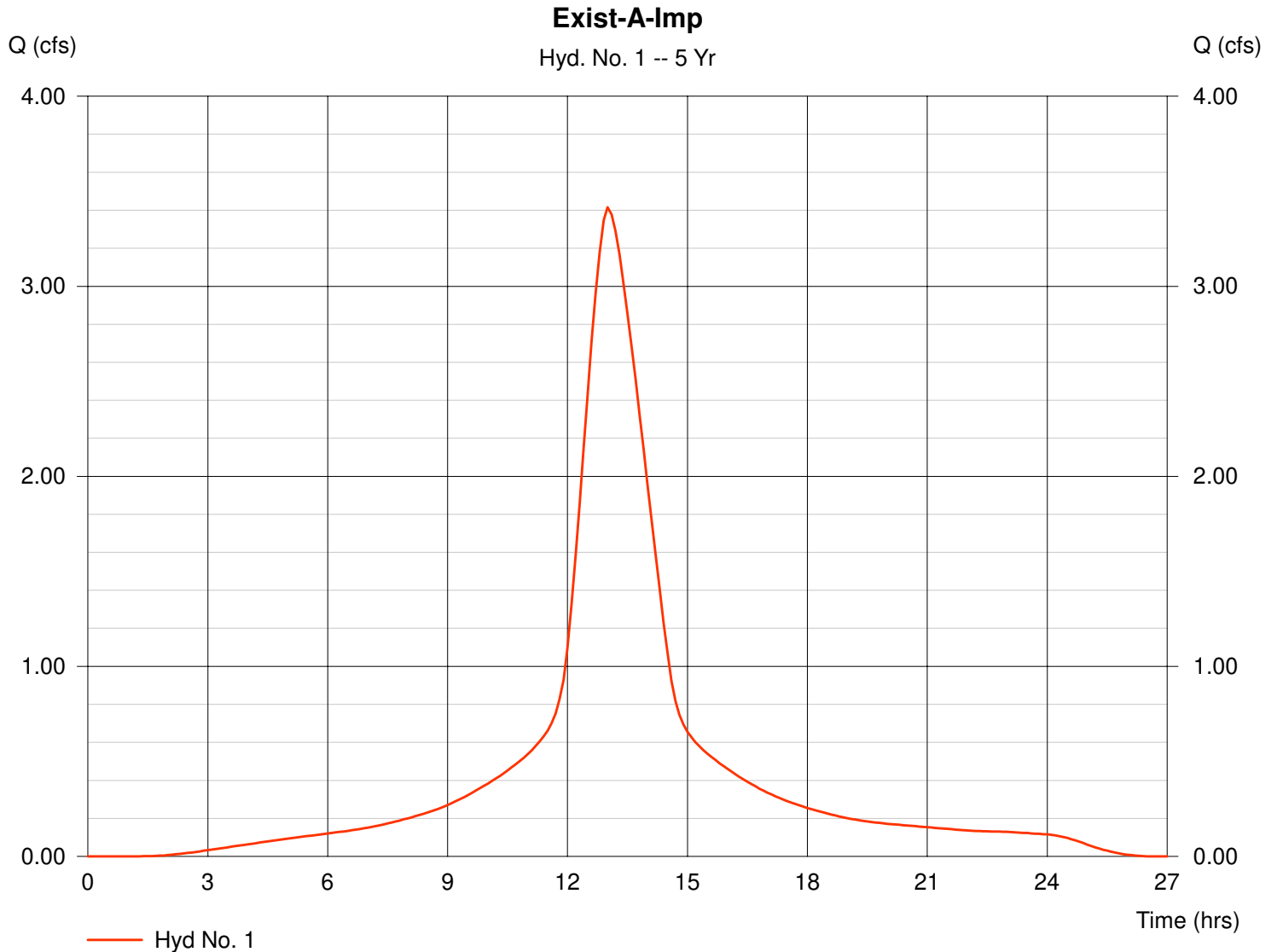

Hydrograph Plot

Hydraflow Hydrographs by Intelisolve

Tuesday, Feb 11 2020, 10:32 AM

Hyd. No. 2

Exist-A-Perv

Hydrograph type = SCS Runoff
Storm frequency = 5 yrs
Drainage area = 123.80 ac
Basin Slope = 0.0 %
Tc method = USER
Total precip. = 4.30 in
Storm duration = 24 hrs

Peak discharge = 1.30 cfs
Time interval = 6 min
Curve number = 39
Hydraulic length = 0 ft
Time of conc. (Tc) = 91.29 min
Distribution = Type III
Shape factor = 484

Hydrograph Volume = 37,154 cuft

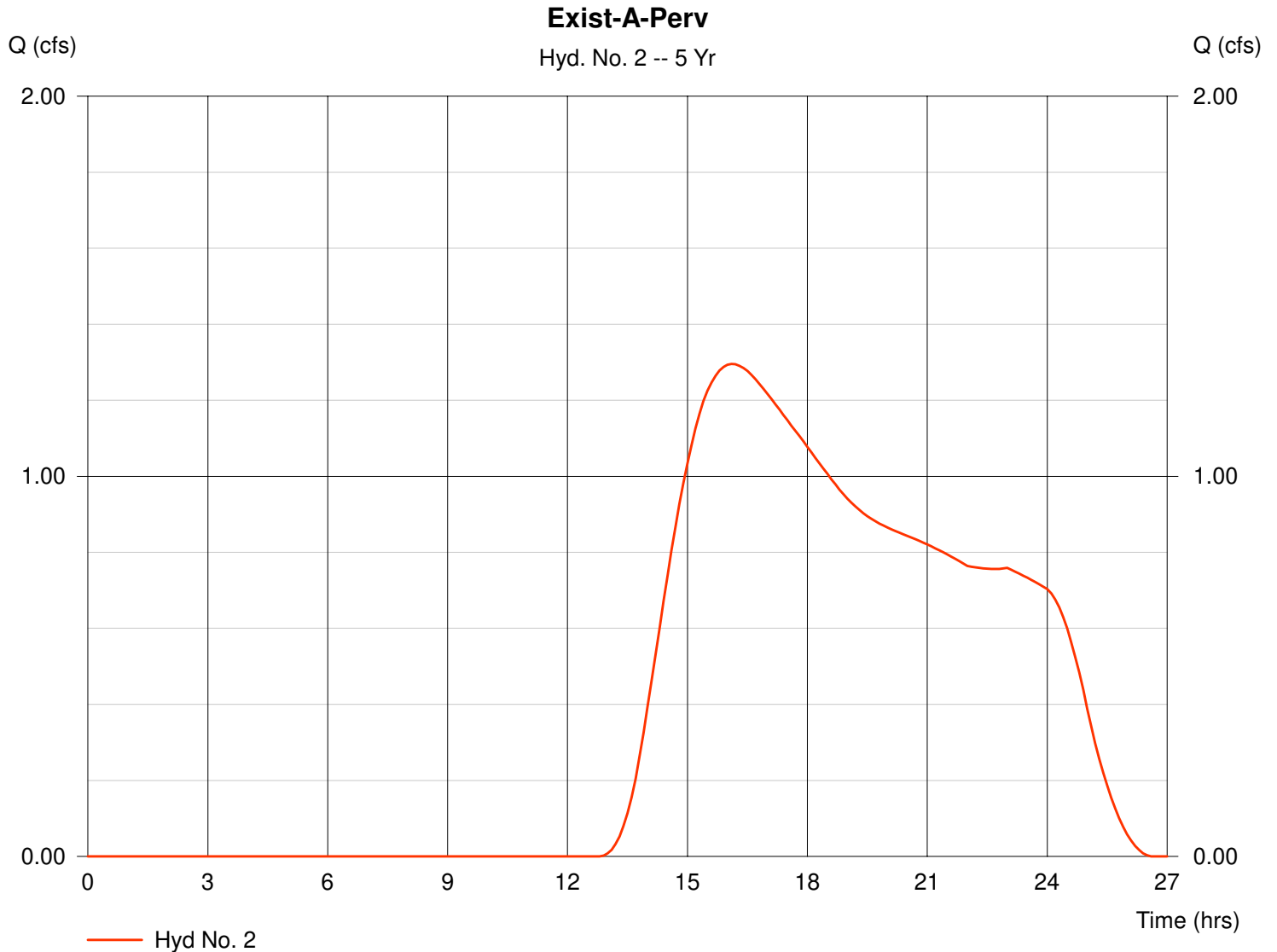

Hydrograph Plot

Hydraflow Hydrographs by Intelisolve

Tuesday, Feb 11 2020, 10:32 AM

Hyd. No. 3

Exist-A

Hydrograph type = Combine
Storm frequency = 5 yrs
Inflow hyds. = 1, 2

Peak discharge = 3.42 cfs
Time interval = 6 min

Hydrograph Volume = 76,591 cuft

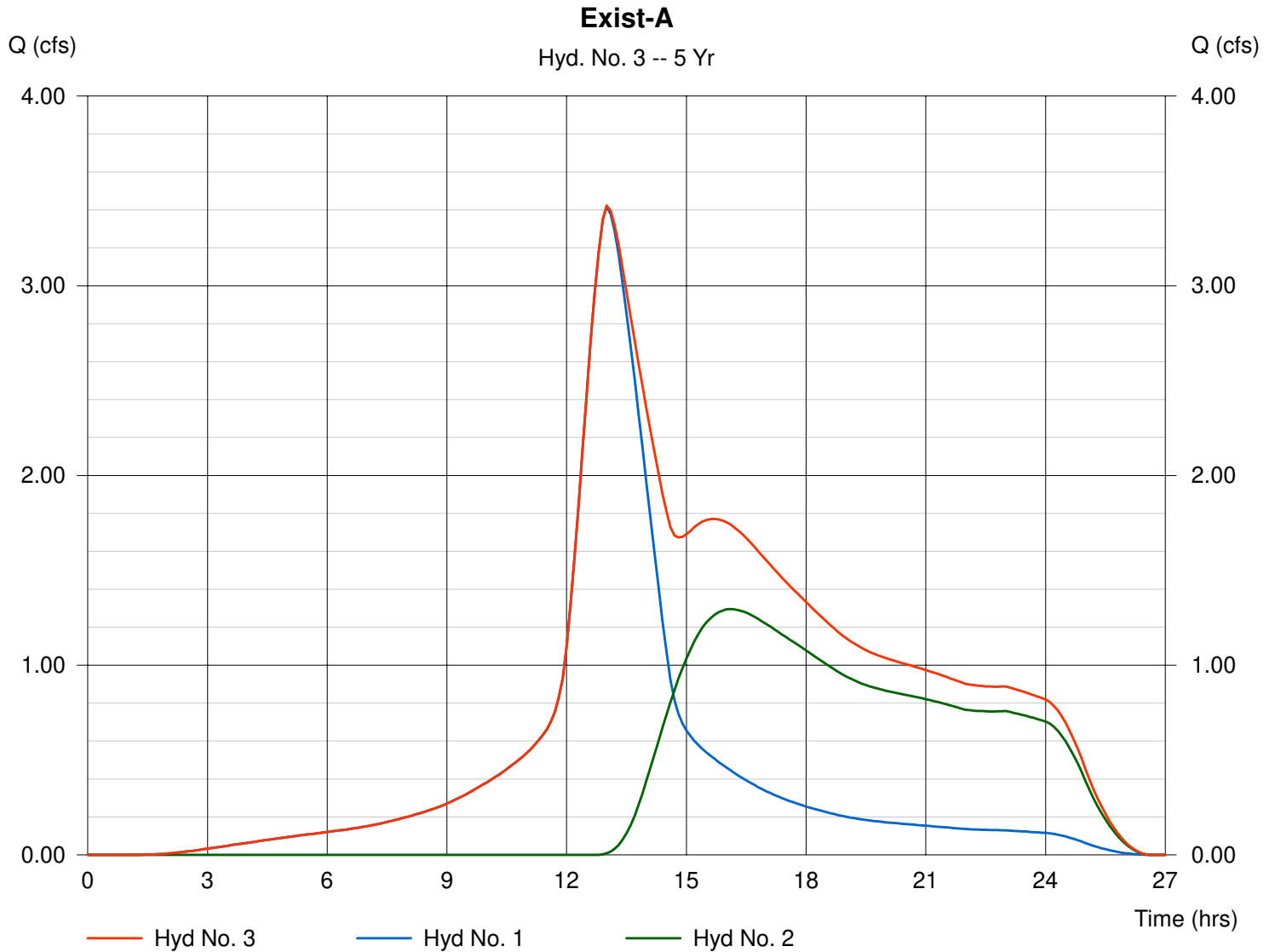

Hydrograph Plot

Hydraflow Hydrographs by Intelisolve

Tuesday, Feb 11 2020, 10:32 AM

Hyd. No. 5

Prop-A-Imp

Hydrograph type = SCS Runoff
Storm frequency = 5 yrs
Drainage area = 2.39 ac
Basin Slope = 0.0 %
Tc method = USER
Total precip. = 4.30 in
Storm duration = 24 hrs

Peak discharge = 3.29 cfs
Time interval = 6 min
Curve number = 98
Hydraulic length = 0 ft
Time of conc. (Tc) = 90.72 min
Distribution = Type III
Shape factor = 484

Hydrograph Volume = 35,262 cuft

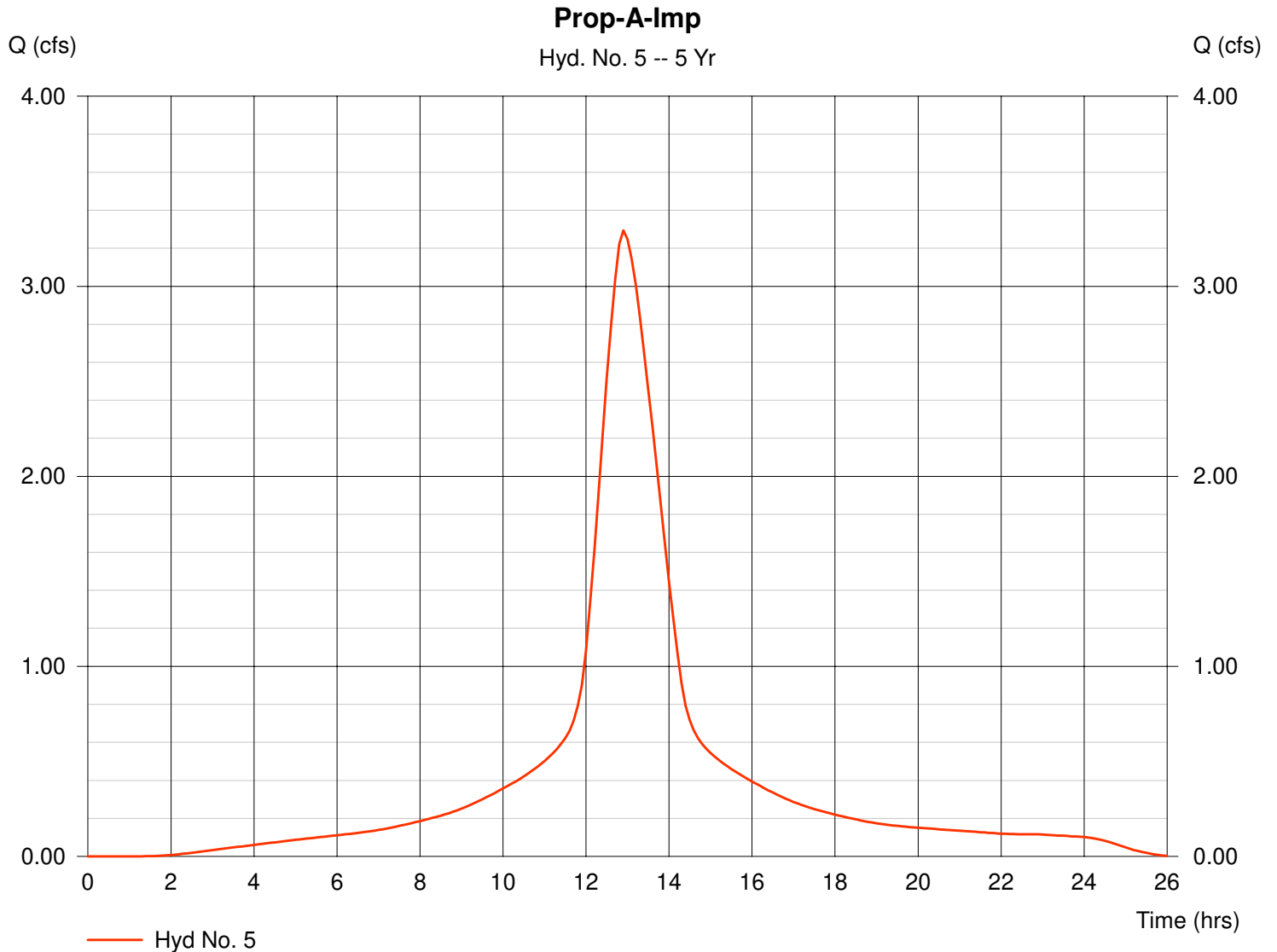

Hydrograph Plot

Hydraflow Hydrographs by Intelisolve

Tuesday, Feb 11 2020, 10:32 AM

Hyd. No. 6

Prop-A-Perv

Hydrograph type = SCS Runoff
Storm frequency = 5 yrs
Drainage area = 114.63 ac
Basin Slope = 0.0 %
Tc method = USER
Total precip. = 4.30 in
Storm duration = 24 hrs

Peak discharge = 1.55 cfs
Time interval = 6 min
Curve number = 40
Hydraulic length = 0 ft
Time of conc. (Tc) = 90.7 min
Distribution = Type III
Shape factor = 484

Hydrograph Volume = 43,133 cuft

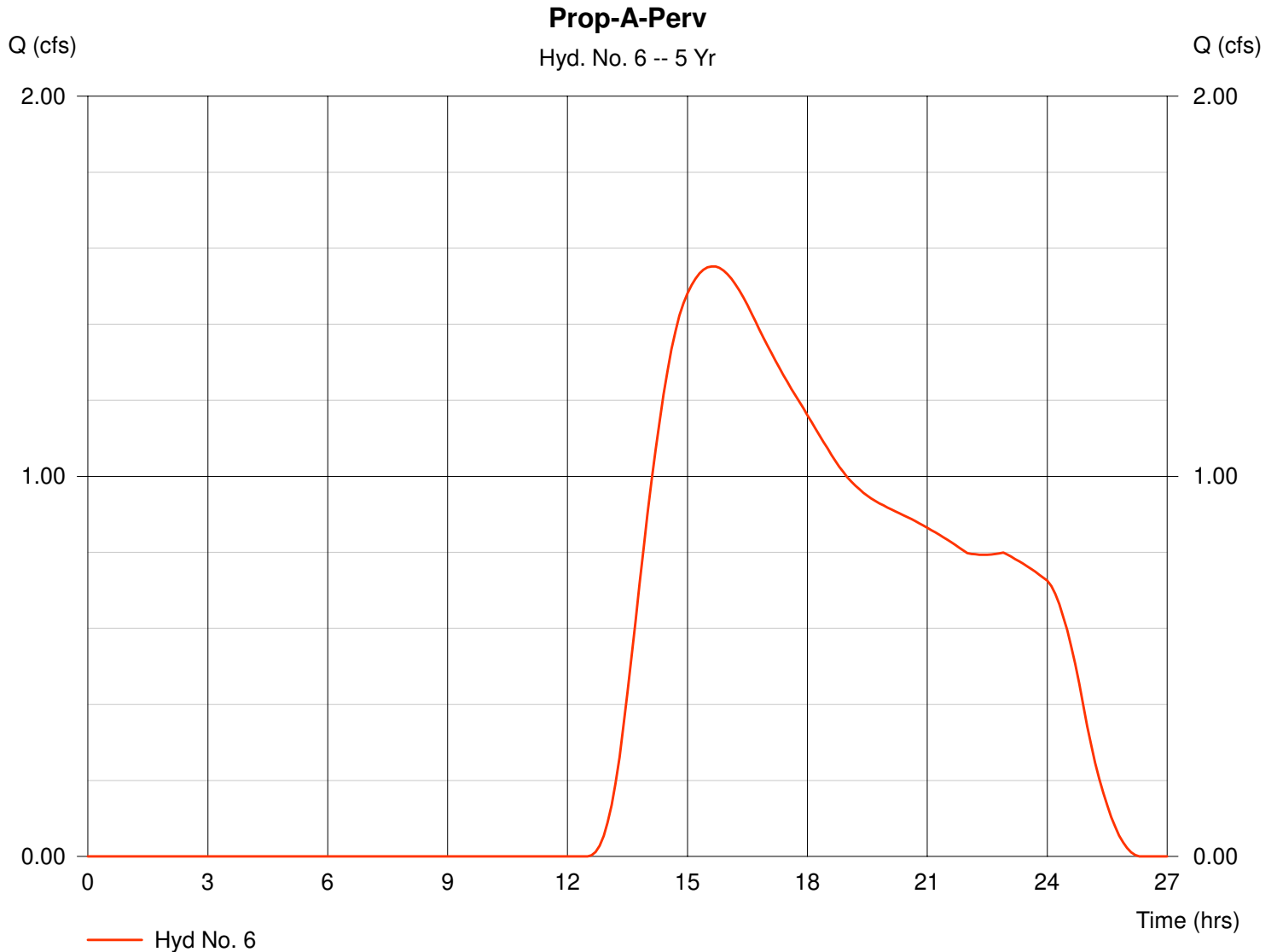

Hydrograph Plot

Hydraflow Hydrographs by Intelisolve

Tuesday, Feb 11 2020, 10:32 AM

Hyd. No. 7

Prop-A

Hydrograph type = Combine
Storm frequency = 5 yrs
Inflow hyds. = 5, 6

Peak discharge = 3.35 cfs
Time interval = 6 min

Hydrograph Volume = 78,394 cuft

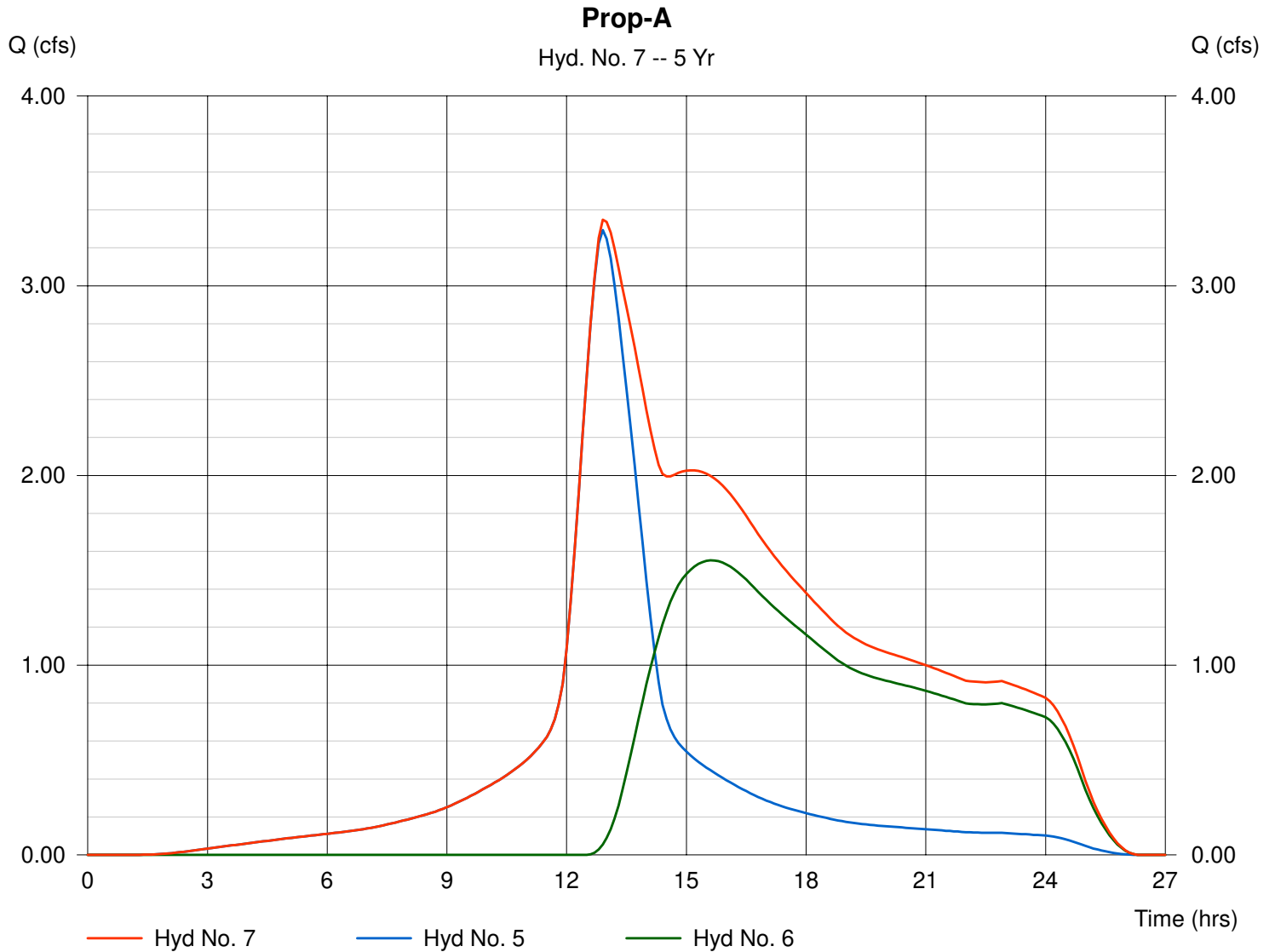

Hydrograph Plot

Hydraflow Hydrographs by Intelisolve

Tuesday, Feb 11 2020, 10:32 AM

Hyd. No. 10

Exist-B-Imp

Hydrograph type = SCS Runoff
 Storm frequency = 5 yrs
 Drainage area = 2.34 ac
 Basin Slope = 0.0 %
 Tc method = USER
 Total precip. = 4.30 in
 Storm duration = 24 hrs

Peak discharge = 3.23 cfs
 Time interval = 6 min
 Curve number = 98
 Hydraulic length = 0 ft
 Time of conc. (Tc) = 87.72 min
 Distribution = Type III
 Shape factor = 484

Hydrograph Volume = 34,524 cuft

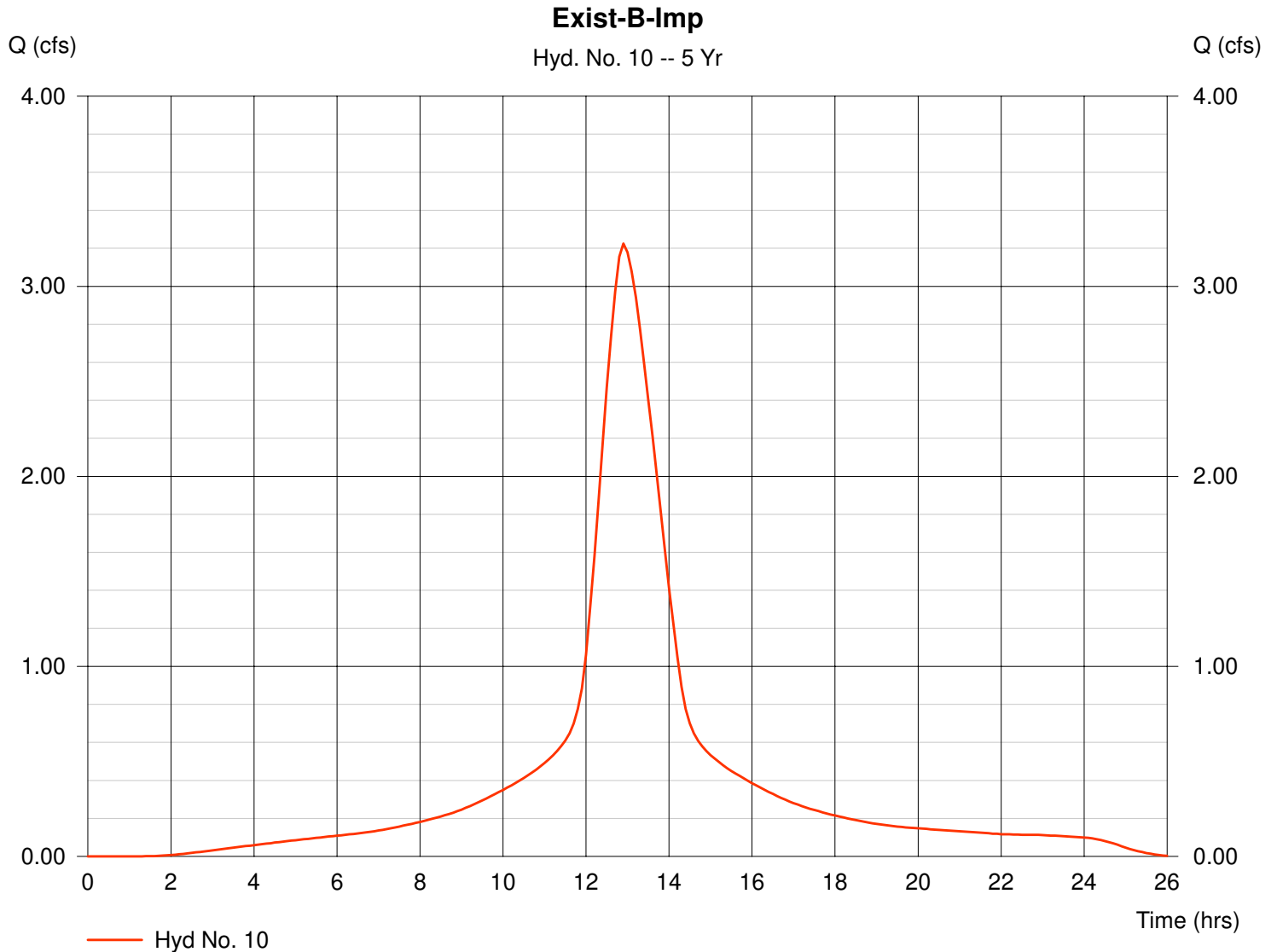

Hydrograph Plot

Hydraflow Hydrographs by Intelisolve

Tuesday, Feb 11 2020, 10:32 AM

Hyd. No. 11

Exist-B-Perv

Hydrograph type = SCS Runoff
Storm frequency = 5 yrs
Drainage area = 124.34 ac
Basin Slope = 0.0 %
Tc method = USER
Total precip. = 4.30 in
Storm duration = 24 hrs

Peak discharge = 0.00 cfs
Time interval = 6 min
Curve number = 30
Hydraulic length = 0 ft
Time of conc. (Tc) = 87.7 min
Distribution = Type III
Shape factor = 484

Hydrograph Volume = 0 cuft

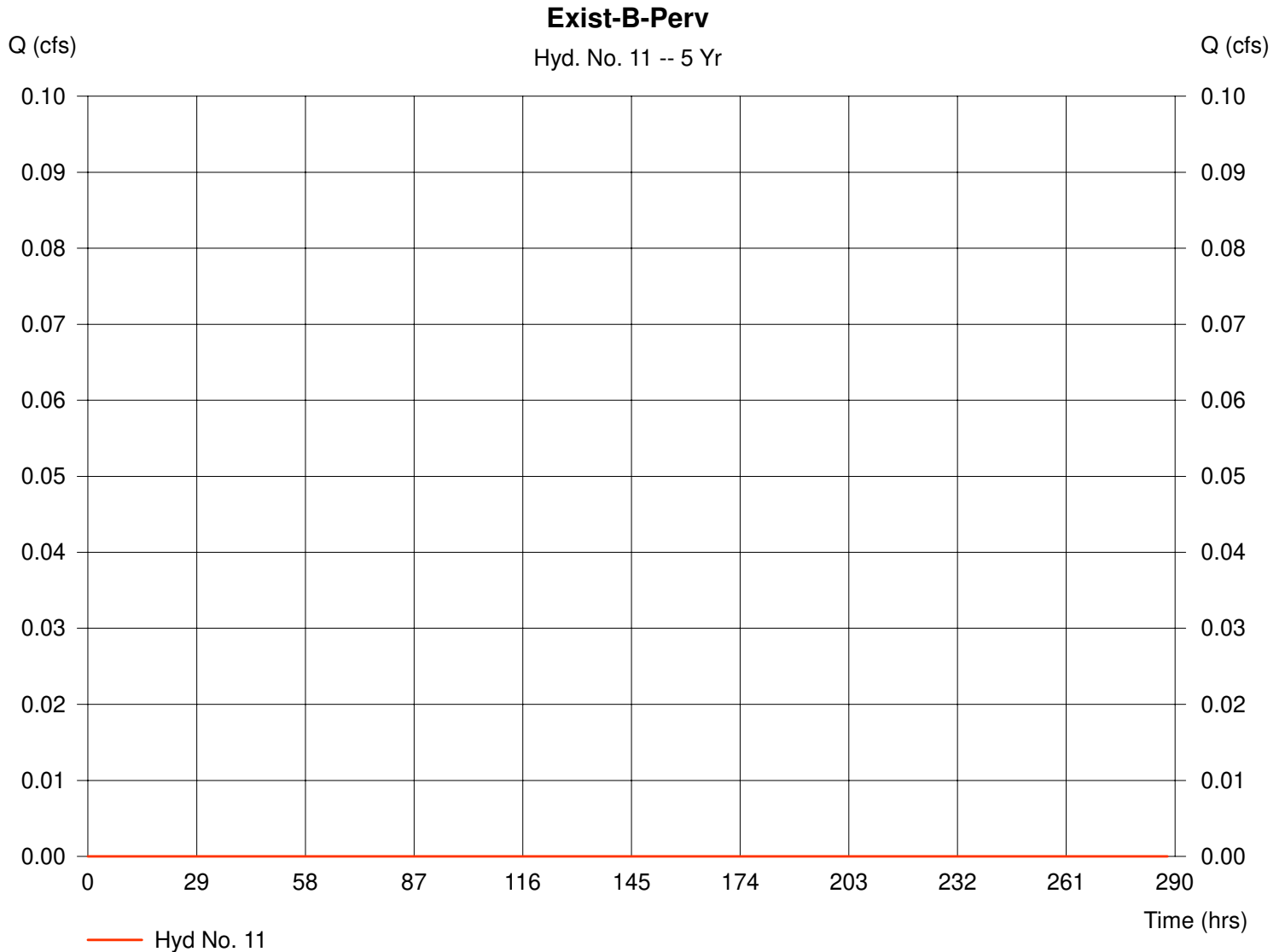

Hydrograph Plot

Hydraflow Hydrographs by Intelisolve

Tuesday, Feb 11 2020, 10:32 AM

Hyd. No. 12

Exist-B

Hydrograph type = Combine
Storm frequency = 5 yrs
Inflow hyds. = 10, 11

Peak discharge = 3.23 cfs
Time interval = 6 min

Hydrograph Volume = 34,524 cuft

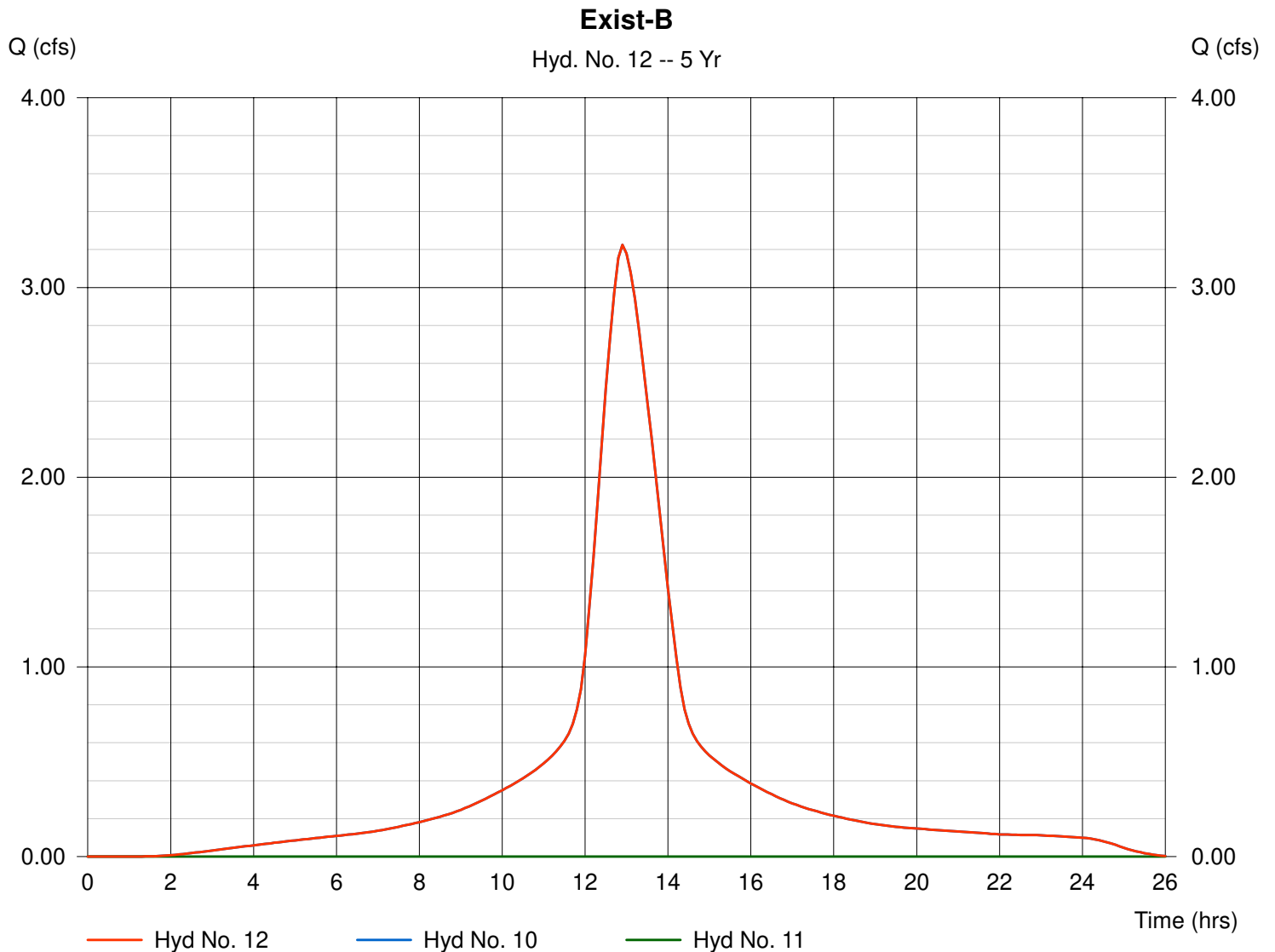

Hydrograph Plot

Hydraflow Hydrographs by Intelisolve

Tuesday, Feb 11 2020, 10:32 AM

Hyd. No. 14

Prop-B-Imp

Hydrograph type = SCS Runoff
Storm frequency = 5 yrs
Drainage area = 0.12 ac
Basin Slope = 0.0 %
Tc method = USER
Total precip. = 4.30 in
Storm duration = 24 hrs

Peak discharge = 0.17 cfs
Time interval = 6 min
Curve number = 98
Hydraulic length = 0 ft
Time of conc. (Tc) = 82.7 min
Distribution = Type III
Shape factor = 484

Hydrograph Volume = 1,770 cuft

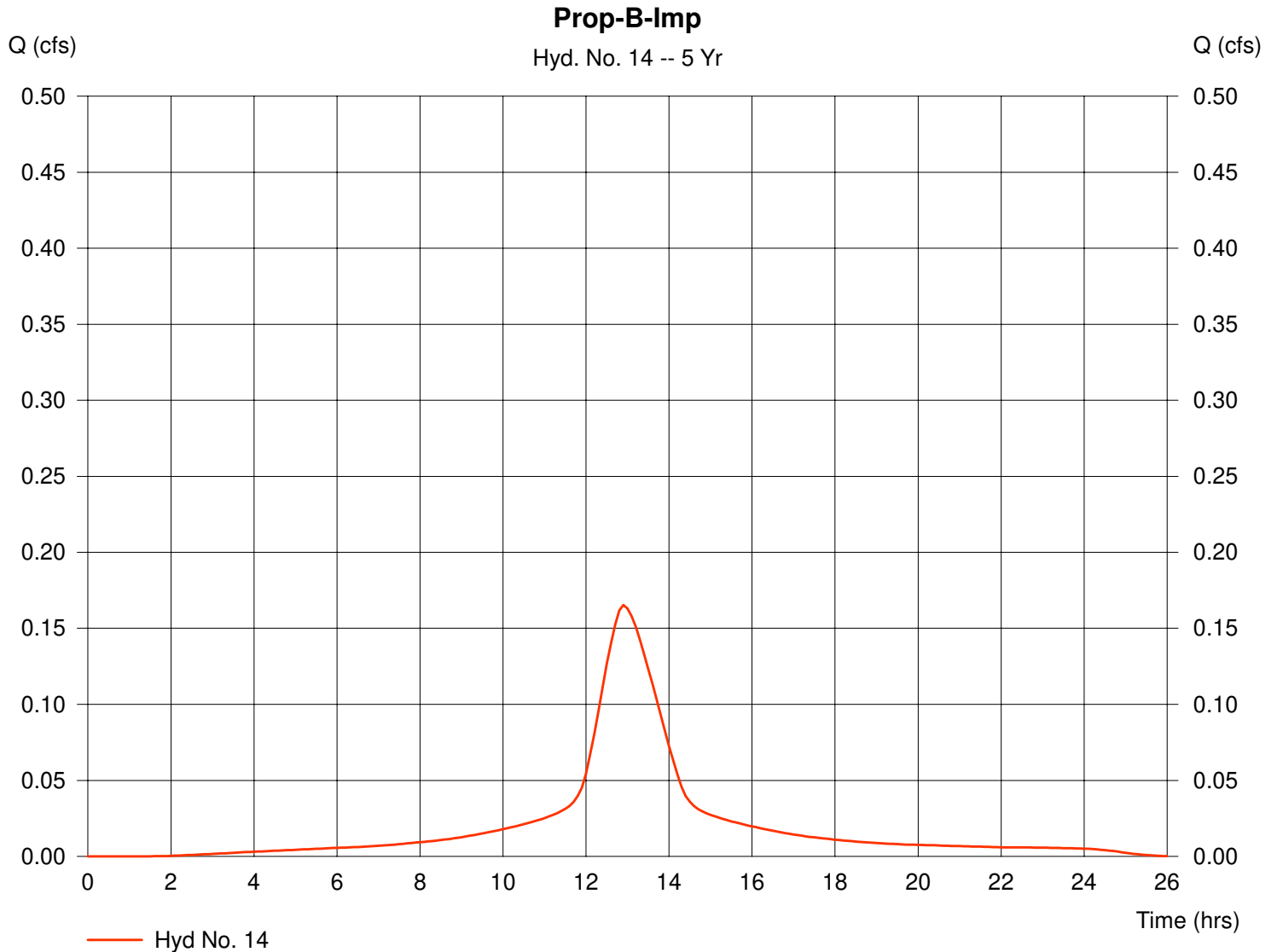

Hydrograph Plot

Hydraflow Hydrographs by Intelisolve

Tuesday, Feb 11 2020, 10:32 AM

Hyd. No. 15

Prop-B-Perv

Hydrograph type = SCS Runoff
Storm frequency = 5 yrs
Drainage area = 38.41 ac
Basin Slope = 0.0 %
Tc method = USER
Total precip. = 4.30 in
Storm duration = 24 hrs

Peak discharge = 0.00 cfs
Time interval = 6 min
Curve number = 31
Hydraulic length = 0 ft
Time of conc. (Tc) = 82.7 min
Distribution = Type III
Shape factor = 484

Hydrograph Volume = 0 cuft

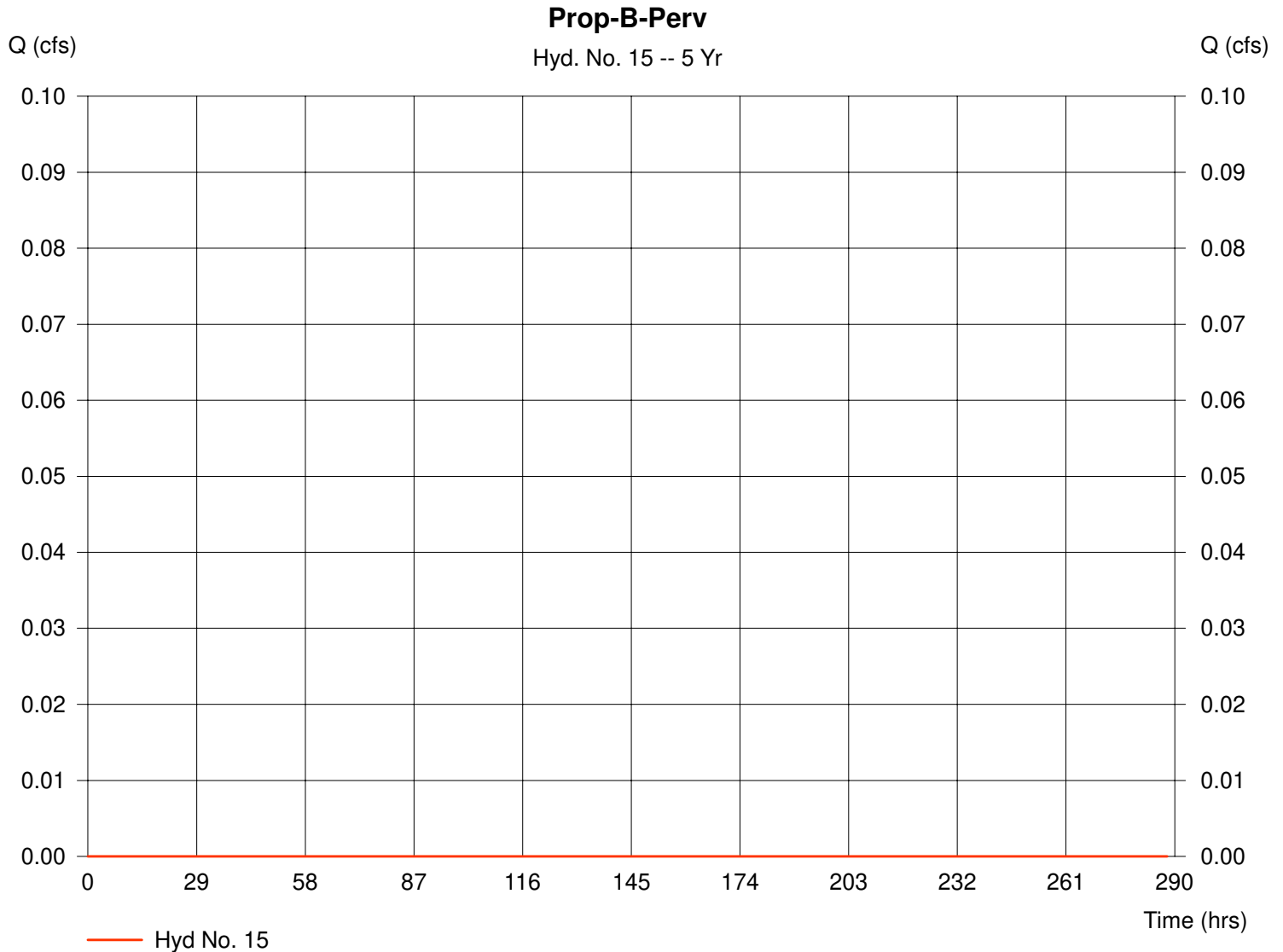

Hydrograph Plot

Hydraflow Hydrographs by Intelisolve

Tuesday, Feb 11 2020, 10:32 AM

Hyd. No. 17

Prop-B-Imp-FAN-Basin

Hydrograph type = SCS Runoff
 Storm frequency = 5 yrs
 Drainage area = 0.63 ac
 Basin Slope = 0.0 %
 Tc method = USER
 Total precip. = 4.30 in
 Storm duration = 24 hrs

Peak discharge = 0.86 cfs
 Time interval = 6 min
 Curve number = 98
 Hydraulic length = 0 ft
 Time of conc. (Tc) = 82.7 min
 Distribution = Type III
 Shape factor = 484

Hydrograph Volume = 9,236 cuft

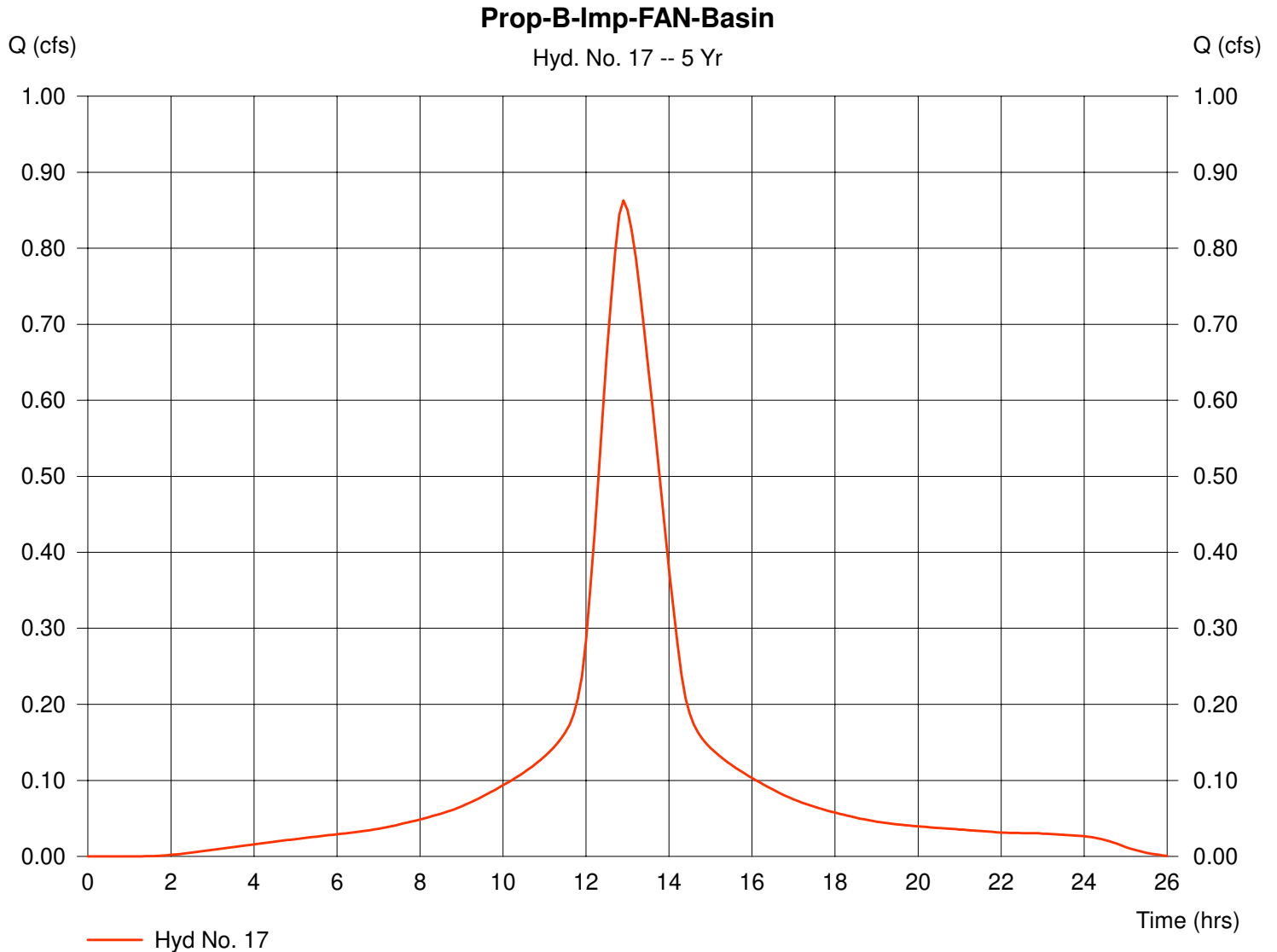

Hydrograph Plot

Hydraflow Hydrographs by Intelisolve

Tuesday, Feb 11 2020, 10:32 AM

Hyd. No. 18

Prop-B-Perv-FAN-Basin

Hydrograph type = SCS Runoff
 Storm frequency = 5 yrs
 Drainage area = 83.82 ac
 Basin Slope = 0.0 %
 Tc method = USER
 Total precip. = 4.30 in
 Storm duration = 24 hrs

Peak discharge = 0.01 cfs
 Time interval = 6 min
 Curve number = 32
 Hydraulic length = 0 ft
 Time of conc. (Tc) = 82.7 min
 Distribution = Type III
 Shape factor = 484

Hydrograph Volume = 36 cuft

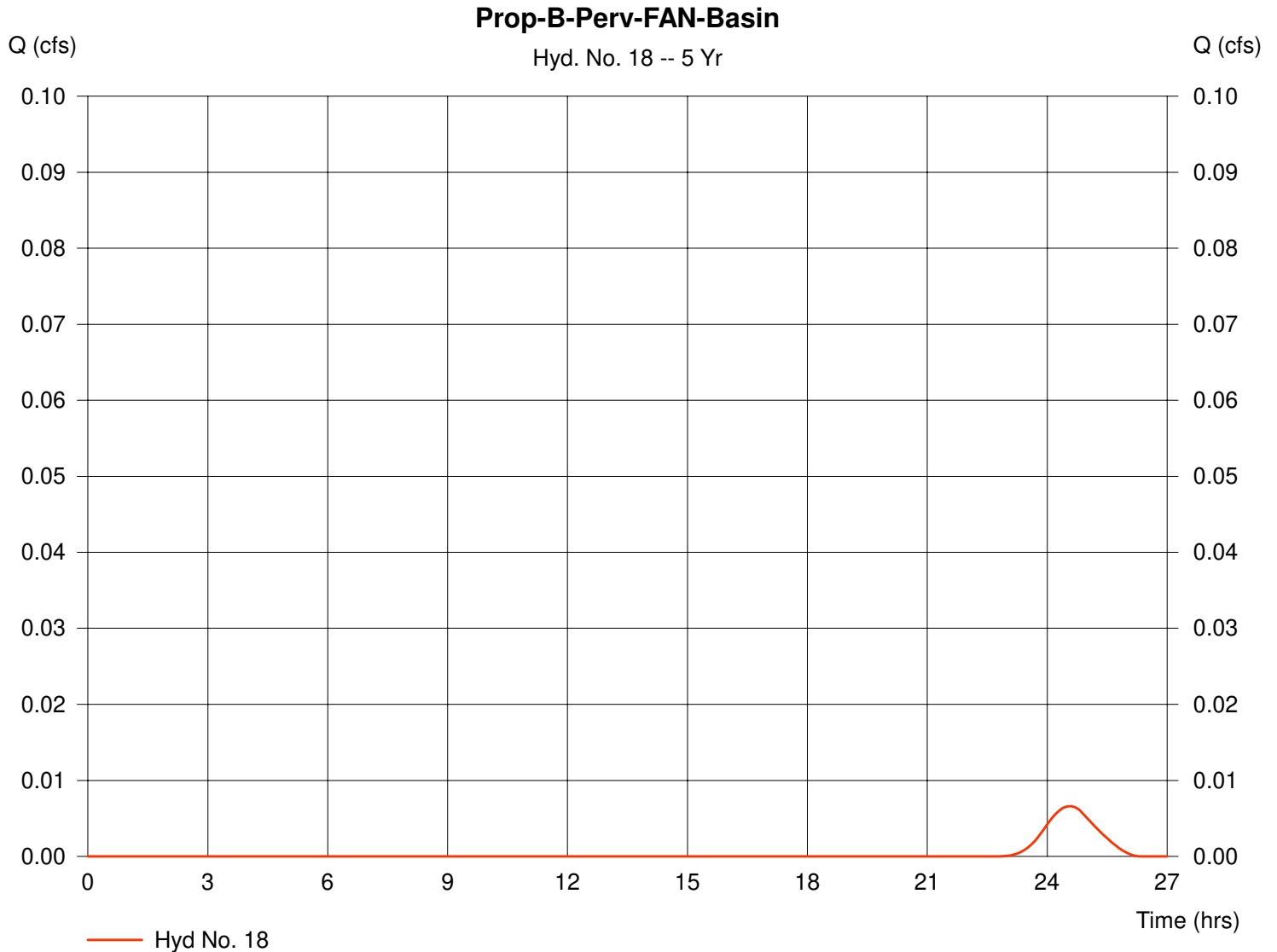

Hydrograph Plot

Hydraflow Hydrographs by Intelisolve

Tuesday, Feb 11 2020, 10:32 AM

Hyd. No. 19

FAN Basin Inflow

Hydrograph type = Combine
Storm frequency = 5 yrs
Inflow hyds. = 17, 18

Peak discharge = 0.86 cfs
Time interval = 6 min

Hydrograph Volume = 9,272 cuft

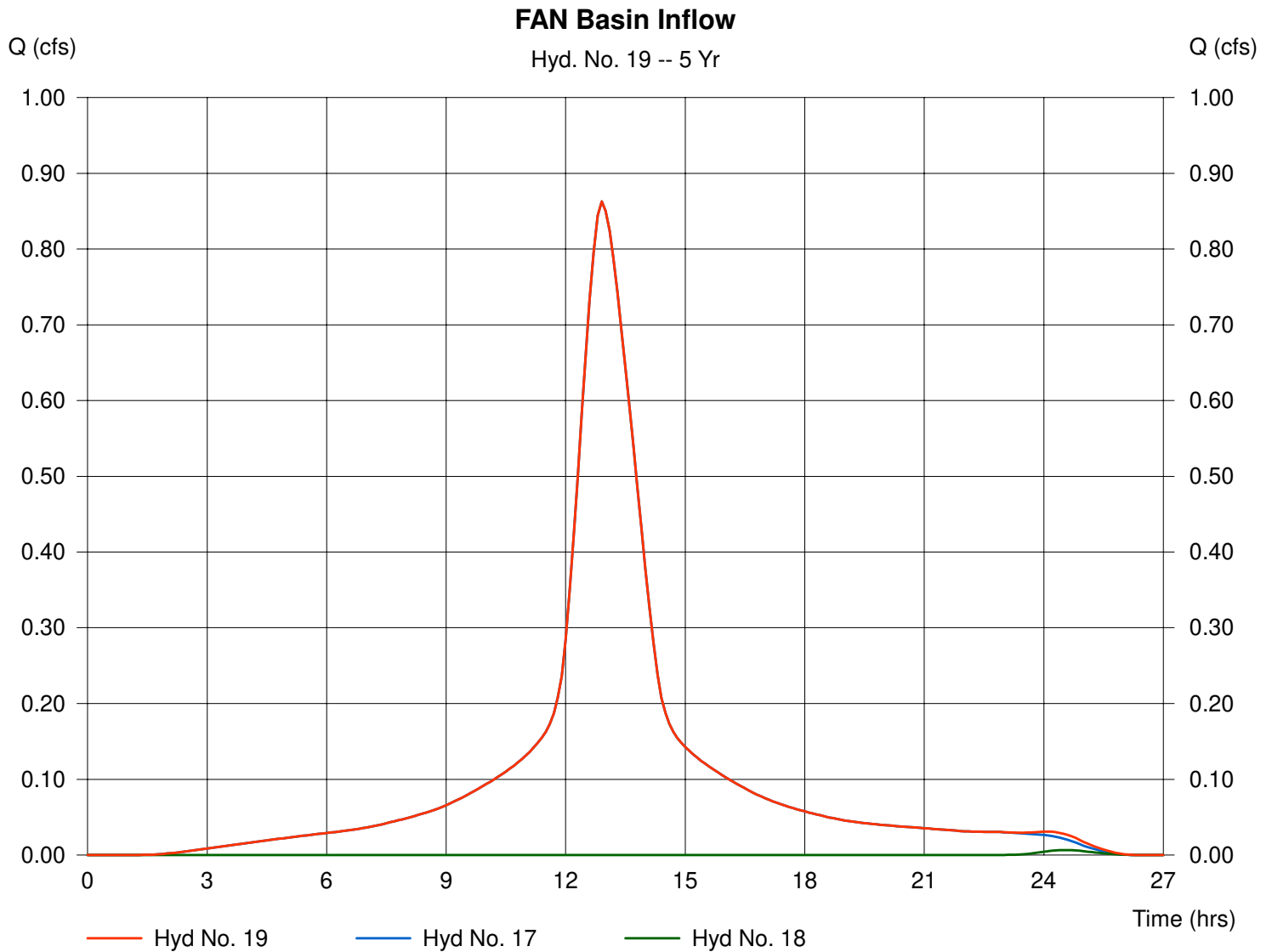

Hydrograph Plot

Hydraflow Hydrographs by Intelisolve

Tuesday, Feb 11 2020, 10:32 AM

Hyd. No. 20

FAN Basin 1 Routing

Hydrograph type = Reservoir
Storm frequency = 5 yrs
Inflow hyd. No. = 19
Reservoir name = FAN Basin

Peak discharge = 0.04 cfs
Time interval = 6 min
Max. Elevation = 154.46 ft
Max. Storage = 7,855 cuft

Storage Indication method used.

Hydrograph Volume = 6,134 cuft

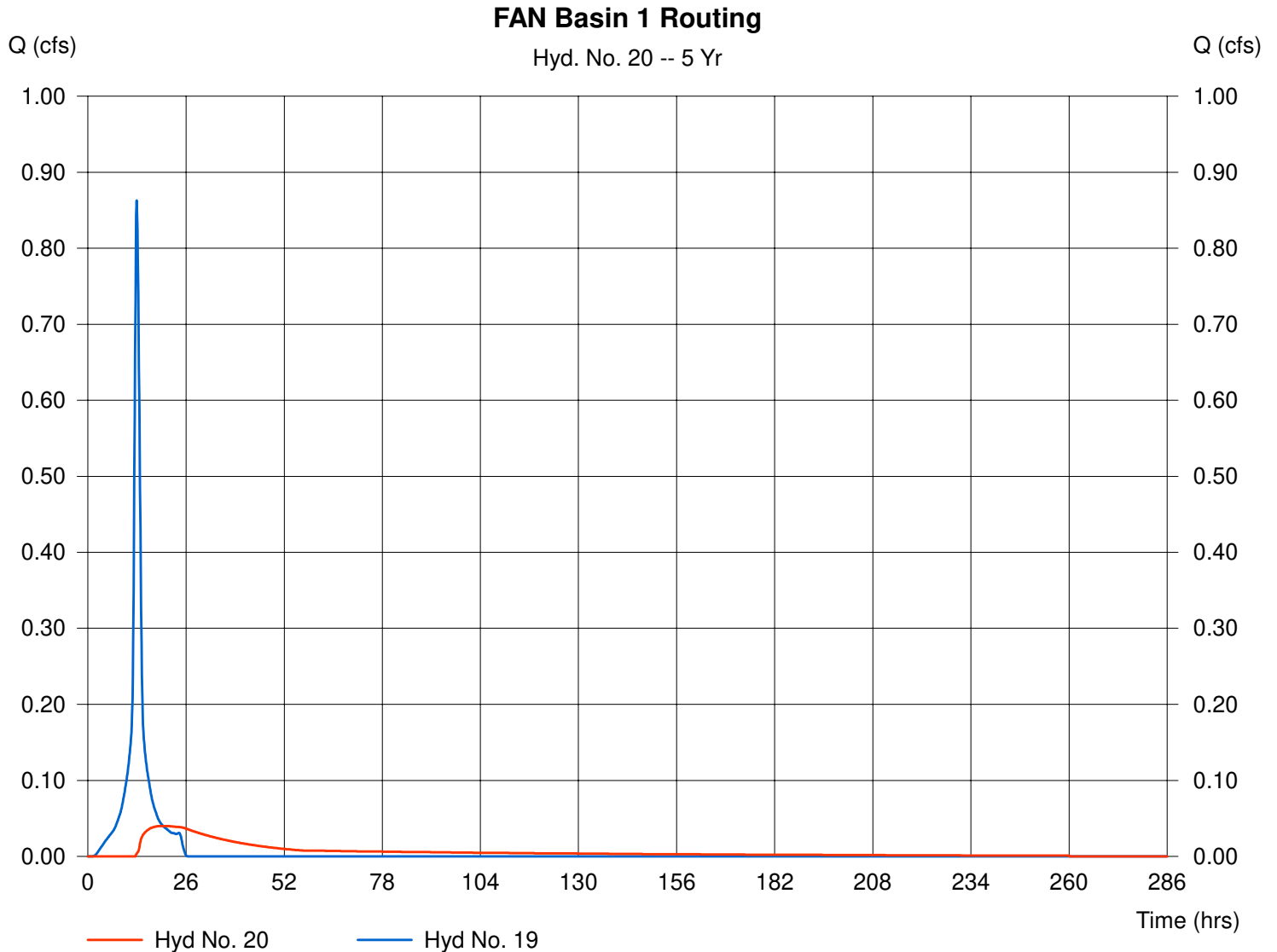

Pond Report

Hydraflow Hydrographs by Intelisolve

Tuesday, Feb 11 2020, 10:32 AM

Pond No. 1 - FAN Basin

Pond Data

Pond storage is based on known contour areas. Average end area method used.

Stage / Storage Table

Stage (ft)	Elevation (ft)	Contour area (sqft)	Incr. Storage (cuft)	Total storage (cuft)
0.00	154.25	36,091	0	0
0.75	155.00	38,058	27,806	27,806
1.75	156.00	40,796	39,427	67,233
2.75	157.00	43,656	42,226	109,459

Culvert / Orifice Structures

	[A]	[B]	[C]	[D]
Rise (in)	= 18.00	6.00	0.00	0.00
Span (in)	= 18.00	6.00	0.00	0.00
No. Barrels	= 1	1	0	0
Invert El. (ft)	= 154.25	154.35	0.00	0.00
Length (ft)	= 38.00	0.00	0.00	0.00
Slope (%)	= 3.30	0.00	0.00	0.00
N-Value	= .013	.013	.013	.000
Orif. Coeff.	= 0.60	0.60	0.60	0.00
Multi-Stage	= n/a	Yes	No	No

Weir Structures

	[A]	[B]	[C]	[D]
Crest Len (ft)	= 16.00	2.00	0.00	0.00
Crest El. (ft)	= 156.50	156.00	0.00	0.00
Weir Coeff.	= 3.33	3.33	3.33	0.00
Weir Type	= Riser	Rect	---	---
Multi-Stage	= Yes	Yes	No	No

Exfiltration = 0.000 in/hr (Contour) Tailwater Elev. = 0.00 ft

Note: Culvert/Orifice outflows have been analyzed under inlet and outlet control.

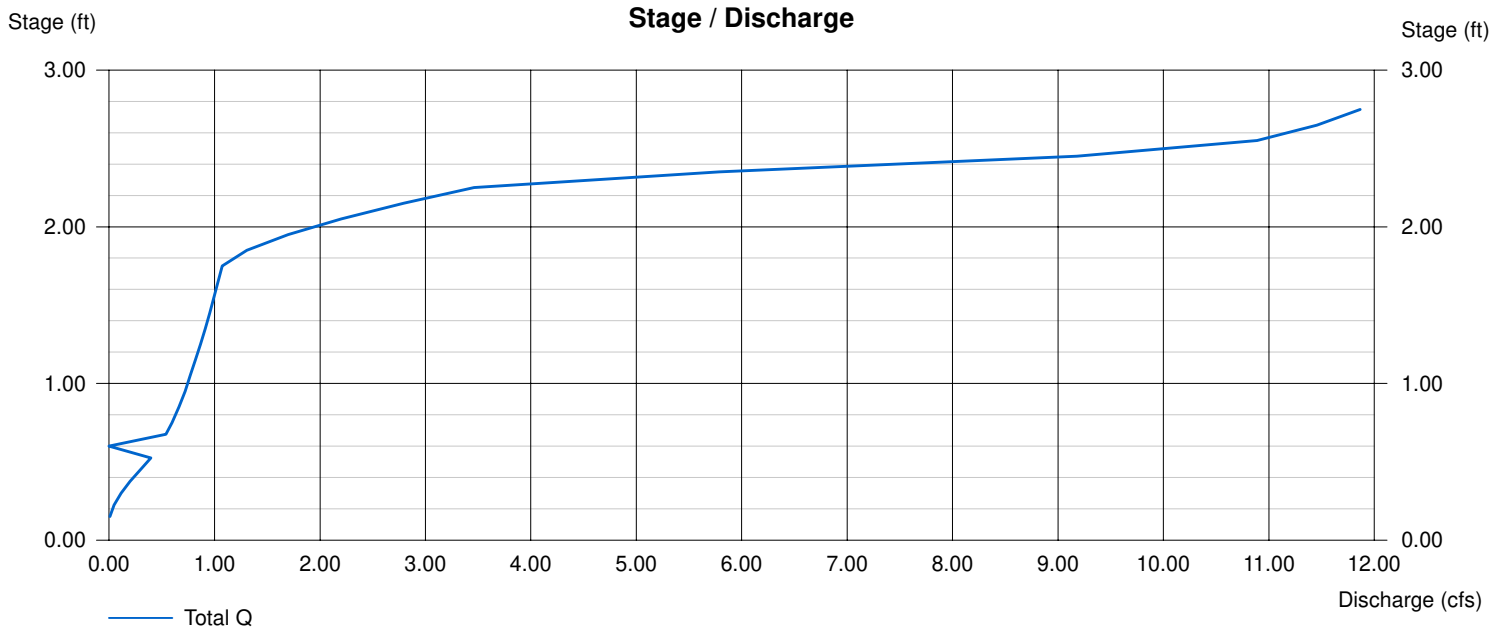

Hydrograph Plot

Hydraflow Hydrographs by Intelisolve

Tuesday, Feb 11 2020, 10:32 AM

Hyd. No. 21

Prop-B-Imp-ROCA-Basin

Hydrograph type = SCS Runoff
Storm frequency = 5 yrs
Drainage area = 0.20 ac
Basin Slope = 0.0 %
Tc method = USER
Total precip. = 4.30 in
Storm duration = 24 hrs

Peak discharge = 0.28 cfs
Time interval = 6 min
Curve number = 98
Hydraulic length = 0 ft
Time of conc. (Tc) = 82.7 min
Distribution = Type III
Shape factor = 484

Hydrograph Volume = 2,951 cuft

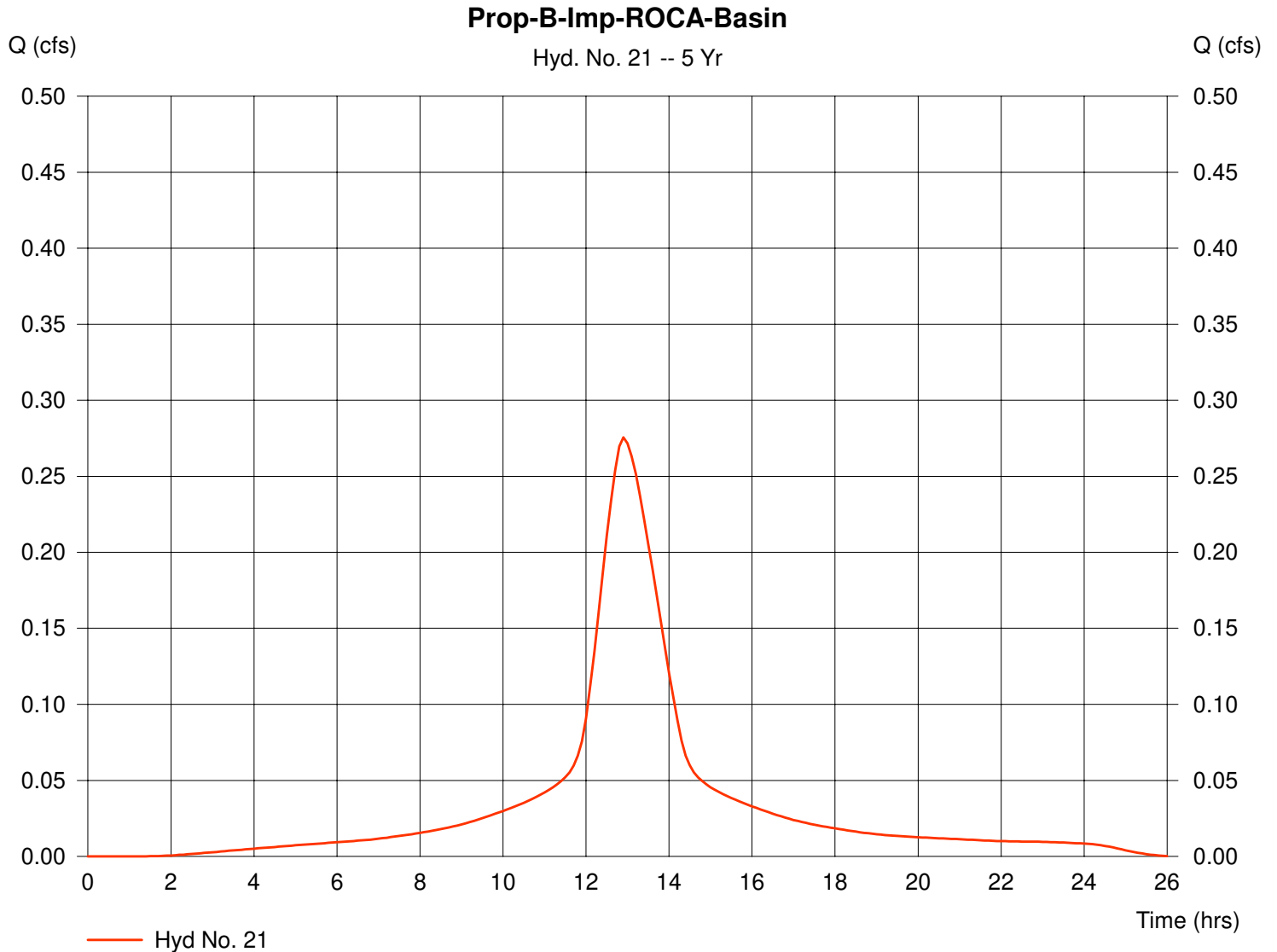

Hydrograph Plot

Hydraflow Hydrographs by Intelisolve

Tuesday, Feb 11 2020, 10:32 AM

Hyd. No. 22

Prop-B-Perv-ROCA-Basin

Hydrograph type = SCS Runoff
Storm frequency = 5 yrs
Drainage area = 10.79 ac
Basin Slope = 0.0 %
Tc method = USER
Total precip. = 4.30 in
Storm duration = 24 hrs

Peak discharge = 0.08 cfs
Time interval = 6 min
Curve number = 38
Hydraulic length = 0 ft
Time of conc. (Tc) = 82.7 min
Distribution = Type III
Shape factor = 484

Hydrograph Volume = 2,426 cuft

Prop-B-Perv-ROCA-Basin

Hyd. No. 22 -- 5 Yr

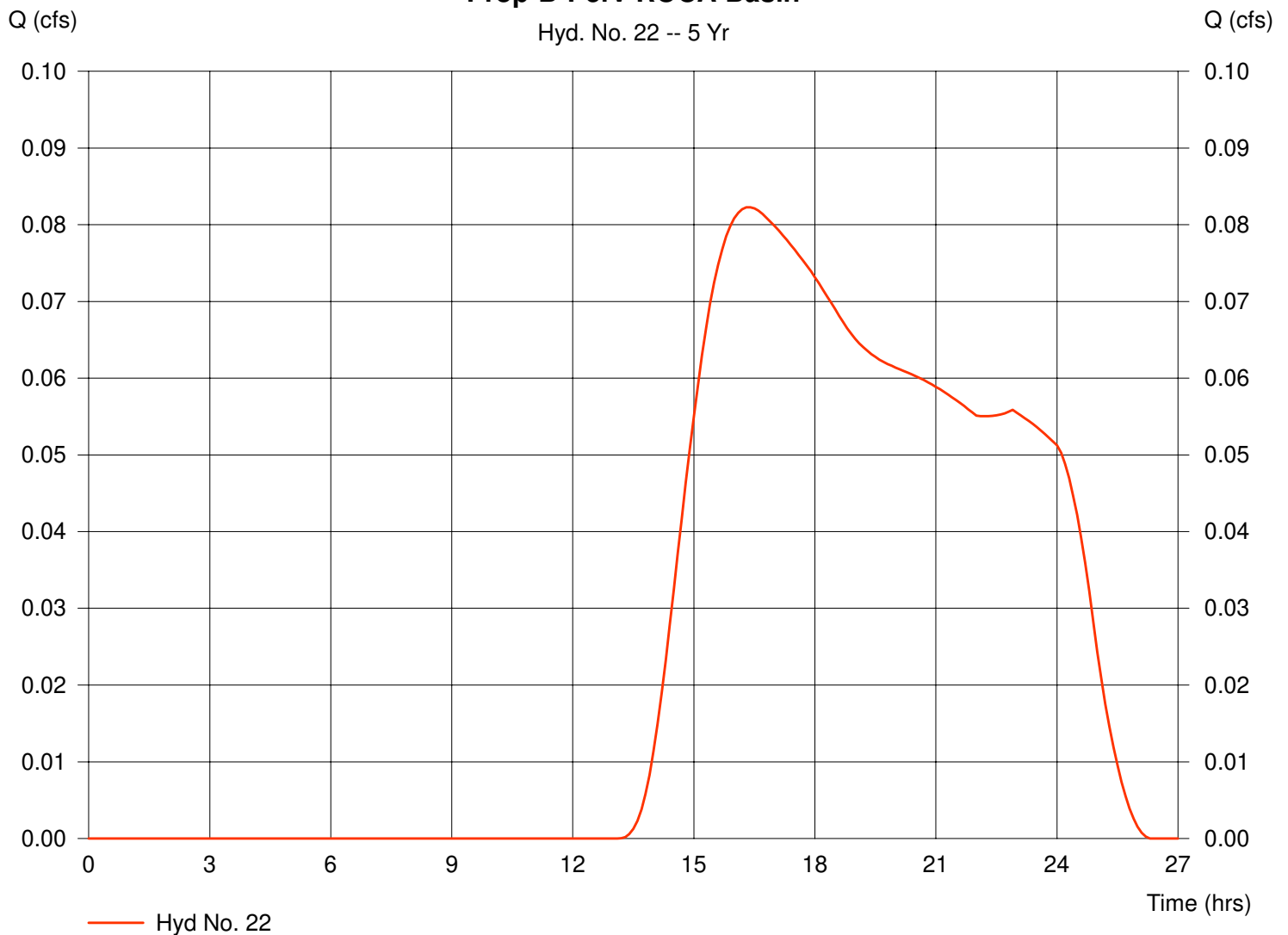

Hydrograph Plot

Hydraflow Hydrographs by Intelisolve

Tuesday, Feb 11 2020, 10:32 AM

Hyd. No. 23

ROCA Basin Inflow

Hydrograph type = Combine
Storm frequency = 5 yrs
Inflow hyds. = 21, 22

Peak discharge = 0.28 cfs
Time interval = 6 min

Hydrograph Volume = 5,377 cuft

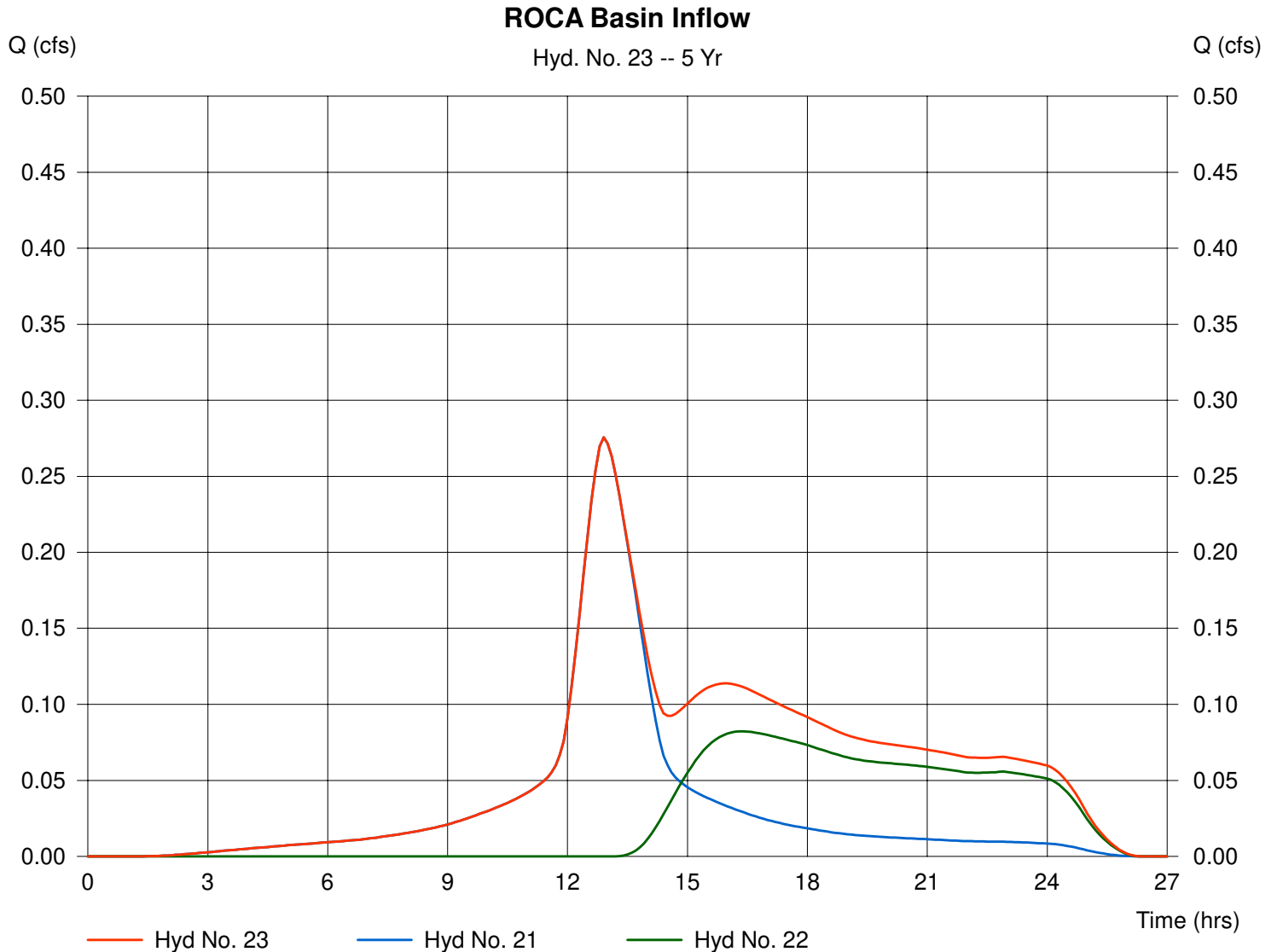

Hydrograph Plot

Hydraflow Hydrographs by Intelisolve

Tuesday, Feb 11 2020, 10:32 AM

Hyd. No. 24

ROCA Basin Routing

Hydrograph type = Reservoir
Storm frequency = 5 yrs
Inflow hyd. No. = 23
Reservoir name = ROCA Basin

Peak discharge = 0.08 cfs
Time interval = 6 min
Max. Elevation = 154.76 ft
Max. Storage = 2,790 cuft

Storage Indication method used.

Hydrograph Volume = 4,250 cuft

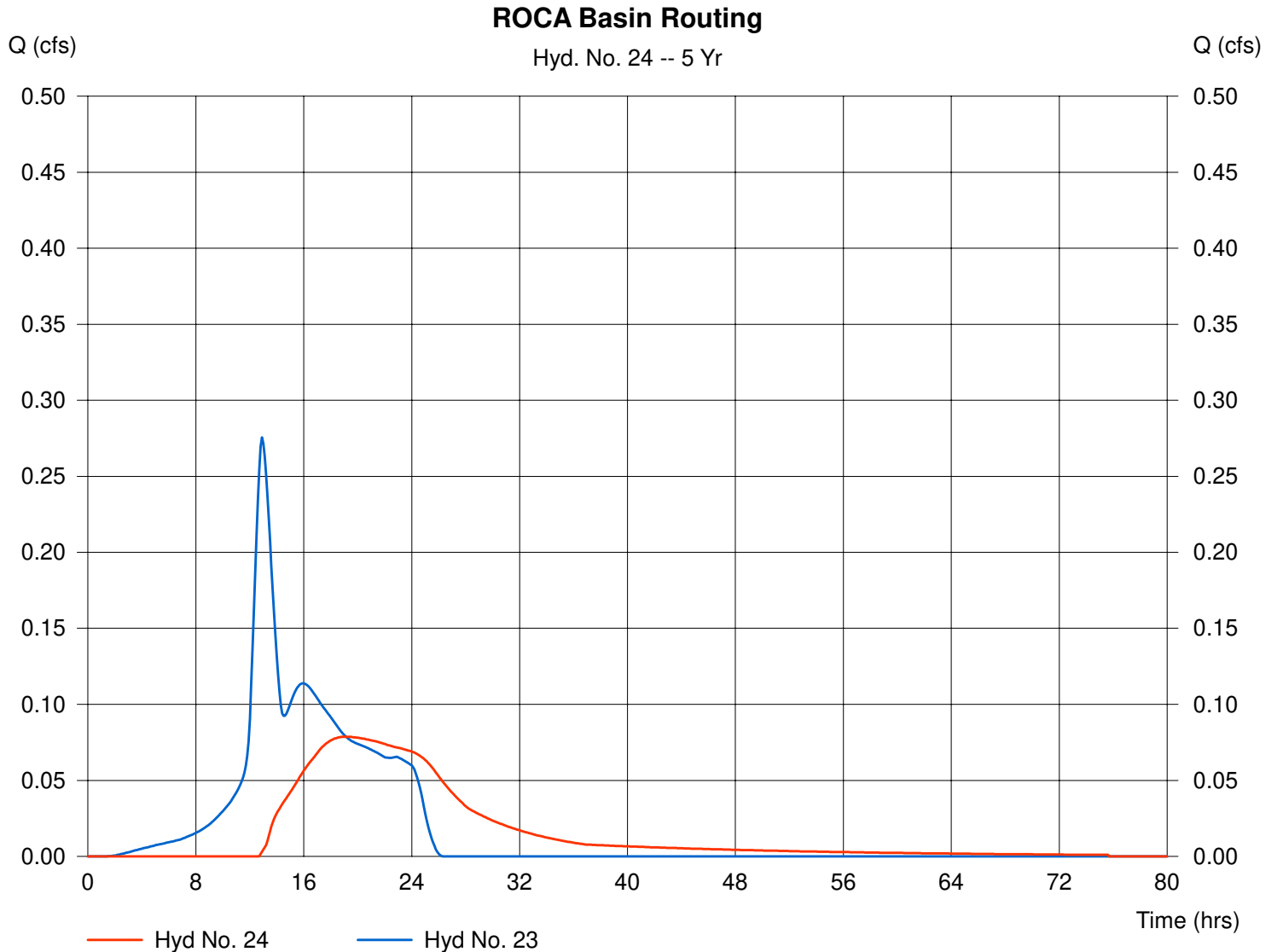

Pond Report

Hydraflow Hydrographs by Intelisolve

Tuesday, Feb 11 2020, 10:32 AM

Pond No. 2 - ROCA Basin

Pond Data

Pond storage is based on known contour areas. Average end area method used.

Stage / Storage Table

Stage (ft)	Elevation (ft)	Contour area (sqft)	Incr. Storage (cuft)	Total storage (cuft)
0.00	154.50	10,126	0	0
0.50	155.00	11,053	5,295	5,295
1.50	156.00	13,036	12,045	17,339
2.00	156.50	14,055	6,773	24,112

Culvert / Orifice Structures

	[A]	[B]	[C]	[D]
Rise (in)	= 18.00	6.00	0.00	0.00
Span (in)	= 18.00	6.00	0.00	0.00
No. Barrels	= 1	1	0	0
Invert El. (ft)	= 154.50	154.60	0.00	0.00
Length (ft)	= 115.00	0.00	0.00	0.00
Slope (%)	= 1.30	0.00	0.00	0.00
N-Value	= .013	.013	.000	.000
Orif. Coeff.	= 0.60	0.60	0.00	0.00
Multi-Stage	= n/a	Yes	No	No

Weir Structures

	[A]	[B]	[C]	[D]
Crest Len (ft)	= 16.00	0.00	0.00	0.00
Crest El. (ft)	= 156.50	0.00	0.00	0.00
Weir Coeff.	= 3.33	3.33	0.00	0.00
Weir Type	= Riser	---	---	---
Multi-Stage	= Yes	No	No	No

Exfiltration = 0.000 in/hr (Contour) Tailwater Elev. = 0.00 ft

Note: Culvert/Orifice outflows have been analyzed under inlet and outlet control.

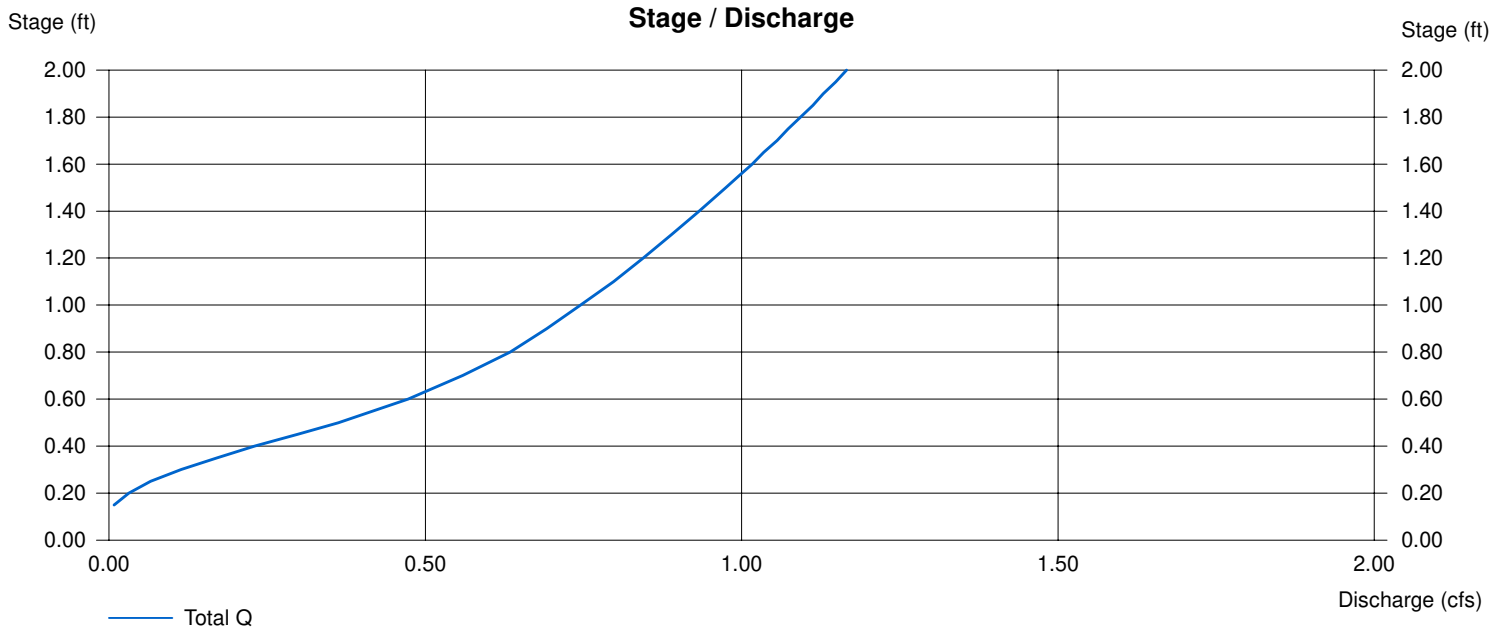

Hydrograph Plot

Hydraflow Hydrographs by Intelisolve

Tuesday, Feb 11 2020, 10:32 AM

Hyd. No. 25

Prop-B

Hydrograph type = Combine
Storm frequency = 5 yrs
Inflow hyds. = 14, 15

Peak discharge = 0.17 cfs
Time interval = 6 min

Hydrograph Volume = 1,770 cuft

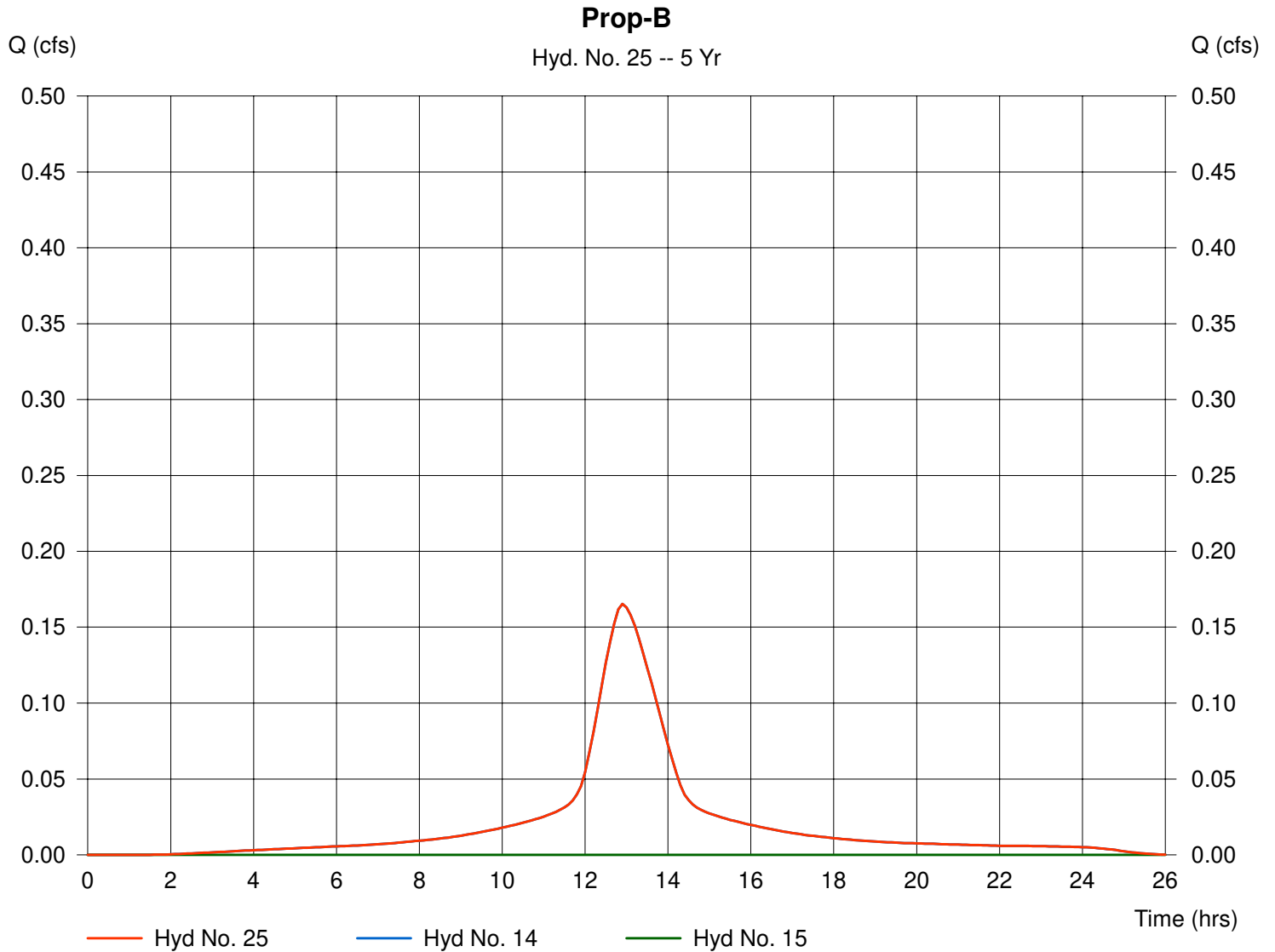

Hydrograph Plot

Hydraflow Hydrographs by Intelisolve

Tuesday, Feb 11 2020, 10:32 AM

Hyd. No. 26

Prop-B

Hydrograph type = Combine
Storm frequency = 5 yrs
Inflow hyds. = 20, 24, 25

Peak discharge = 0.17 cfs
Time interval = 6 min

Hydrograph Volume = 12,155 cuft

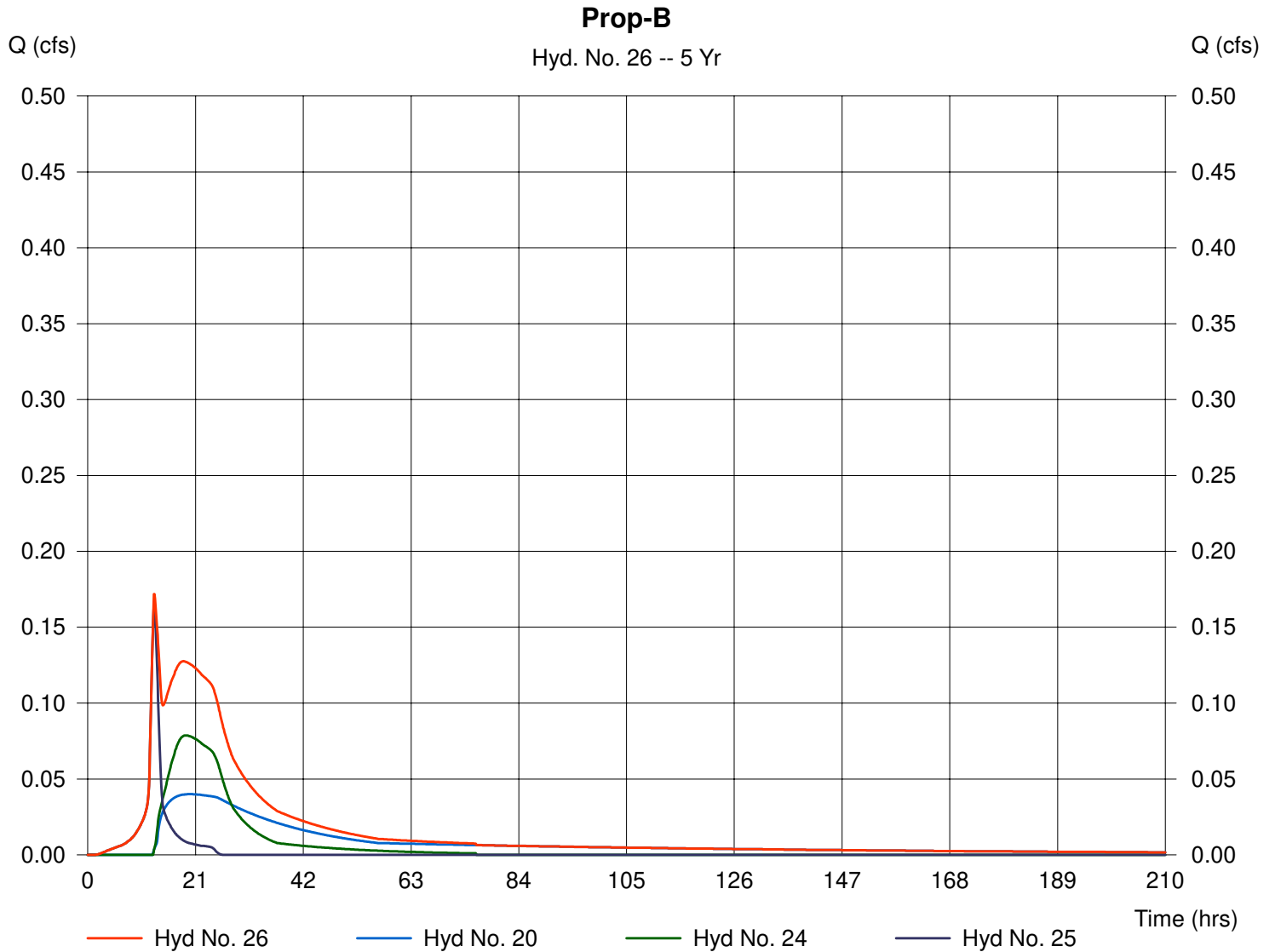

Hydrograph Plot

Hydraflow Hydrographs by Intelisolve

Tuesday, Feb 11 2020, 10:32 AM

Hyd. No. 29

Exist-C-Imp

Hydrograph type = SCS Runoff
 Storm frequency = 5 yrs
 Drainage area = 1.66 ac
 Basin Slope = 0.0 %
 Tc method = USER
 Total precip. = 4.30 in
 Storm duration = 24 hrs

Peak discharge = 2.45 cfs
 Time interval = 6 min
 Curve number = 98
 Hydraulic length = 0 ft
 Time of conc. (Tc) = 76.33 min
 Distribution = Type III
 Shape factor = 484

Hydrograph Volume = 24,109 cuft

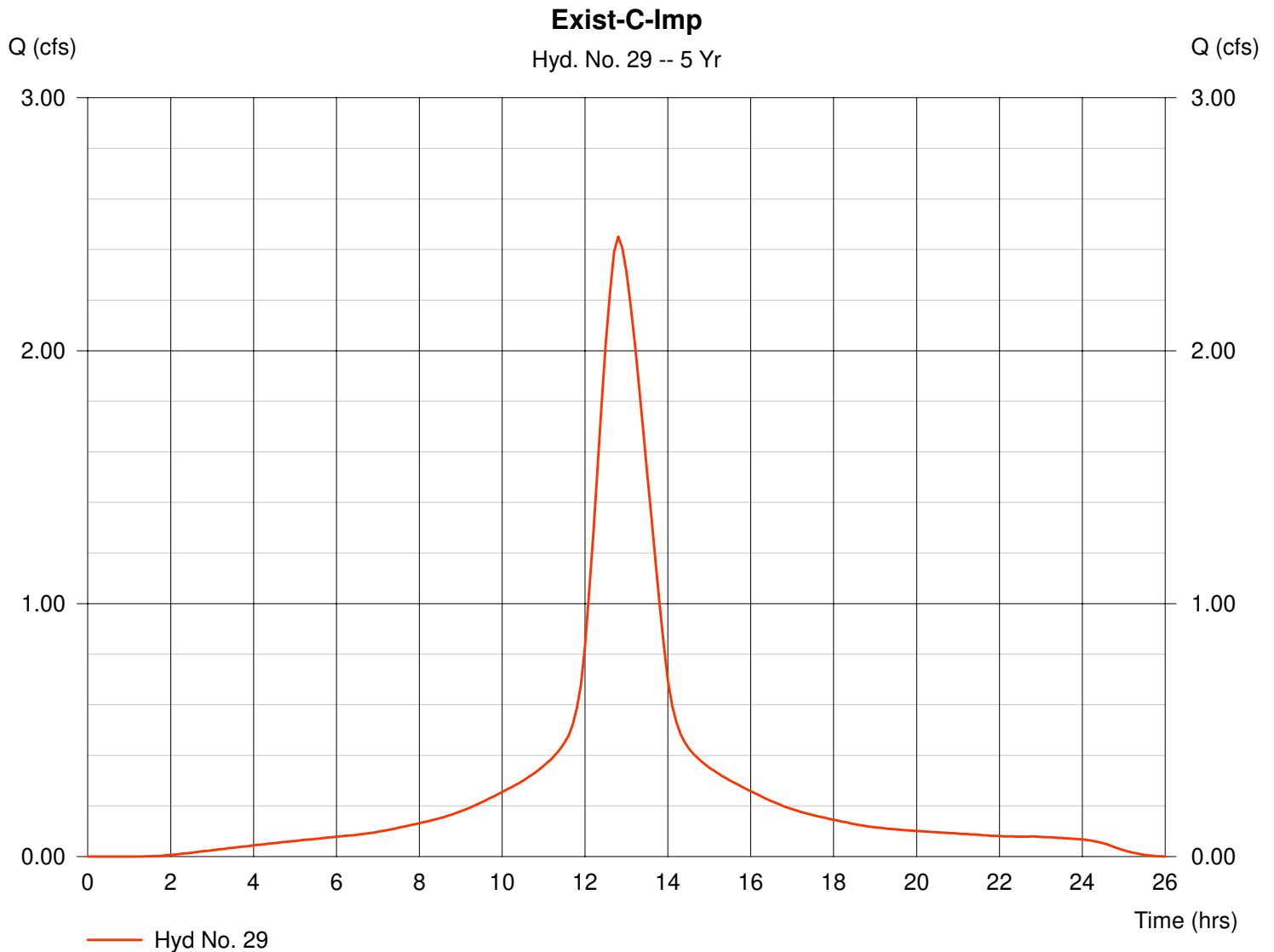

Hydrograph Plot

Hydraflow Hydrographs by Intelisolve

Tuesday, Feb 11 2020, 10:32 AM

Hyd. No. 30

Exist-C-Perv

Hydrograph type = SCS Runoff
Storm frequency = 5 yrs
Drainage area = 130.63 ac
Basin Slope = 0.0 %
Tc method = USER
Total precip. = 4.30 in
Storm duration = 24 hrs

Peak discharge = 1.75 cfs
Time interval = 6 min
Curve number = 40
Hydraulic length = 0 ft
Time of conc. (Tc) = 76.33 min
Distribution = Type III
Shape factor = 484

Hydrograph Volume = 48,385 cuft

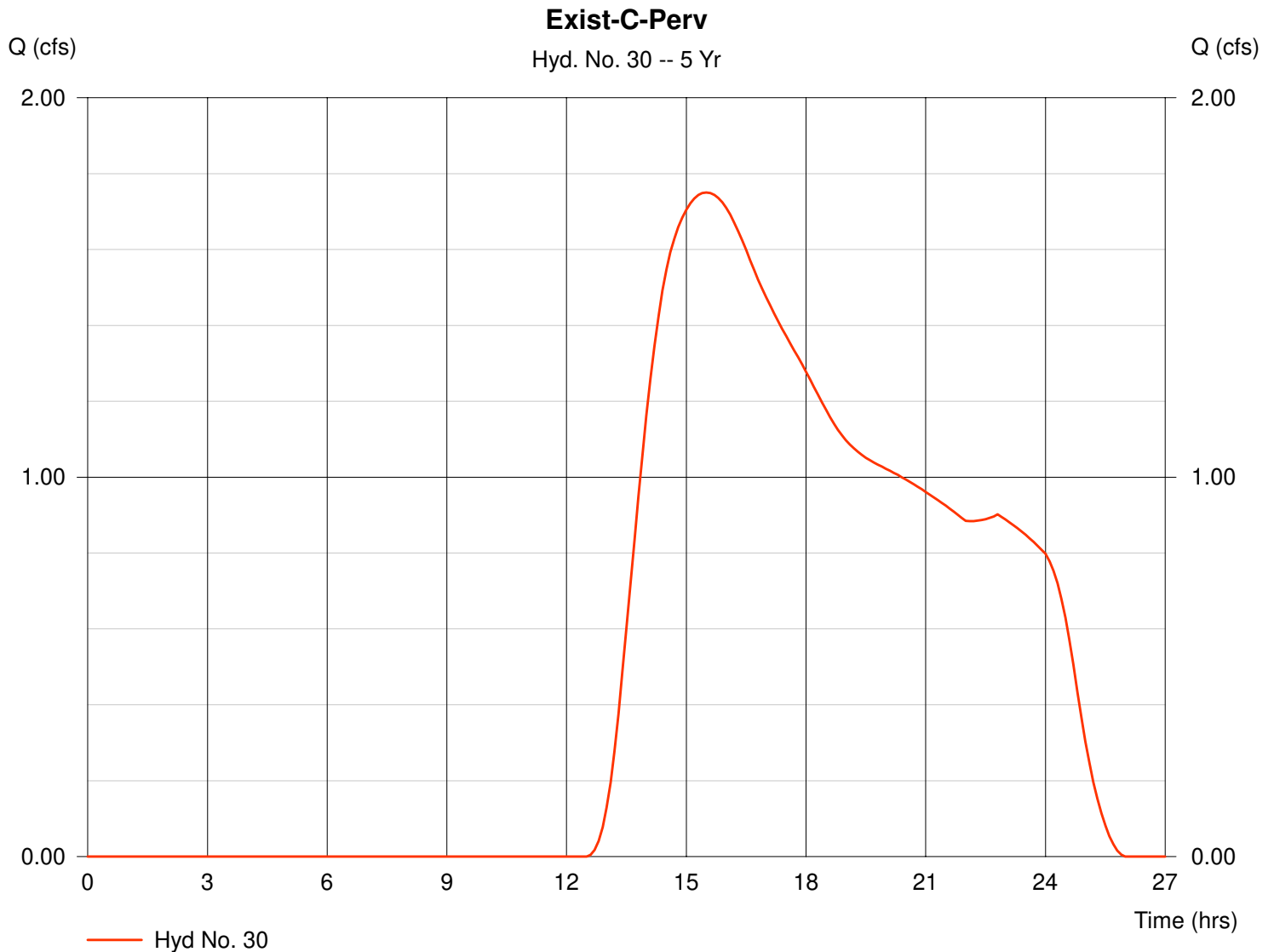

Hydrograph Plot

Hydraflow Hydrographs by Intelisolve

Tuesday, Feb 11 2020, 10:32 AM

Hyd. No. 31

Exist-C

Hydrograph type = Combine
Storm frequency = 5 yrs
Inflow hyds. = 29, 30

Peak discharge = 2.49 cfs
Time interval = 6 min

Hydrograph Volume = 72,494 cuft

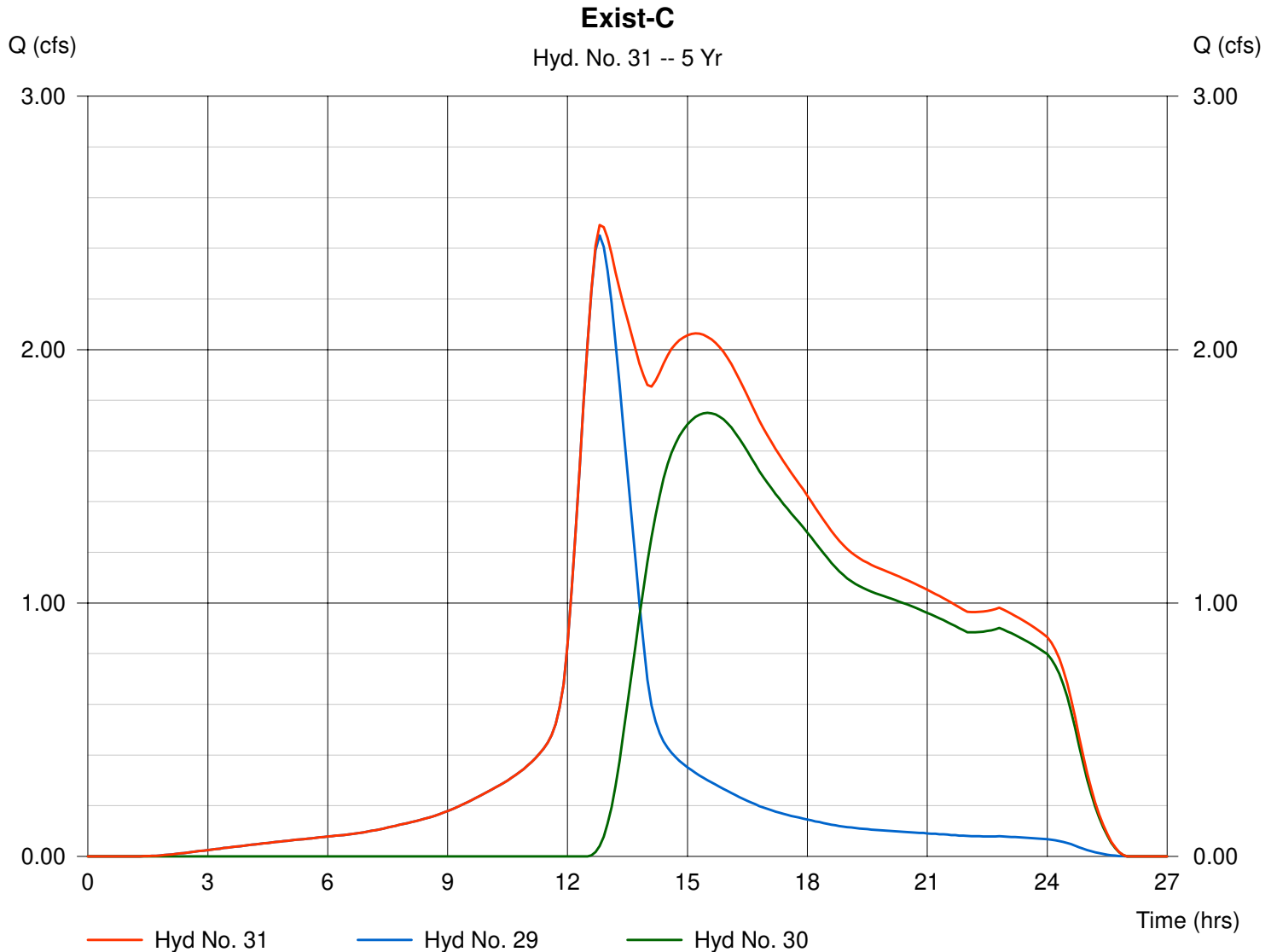

Hydrograph Plot

Hydraflow Hydrographs by Intelisolve

Tuesday, Feb 11 2020, 10:32 AM

Hyd. No. 33

Prop-C-Imp

Hydrograph type = SCS Runoff
 Storm frequency = 5 yrs
 Drainage area = 1.42 ac
 Basin Slope = 0.0 %
 Tc method = USER
 Total precip. = 4.30 in
 Storm duration = 24 hrs

Peak discharge = 2.10 cfs
 Time interval = 6 min
 Curve number = 98
 Hydraulic length = 0 ft
 Time of conc. (Tc) = 75.49 min
 Distribution = Type III
 Shape factor = 484

Hydrograph Volume = 20,623 cuft

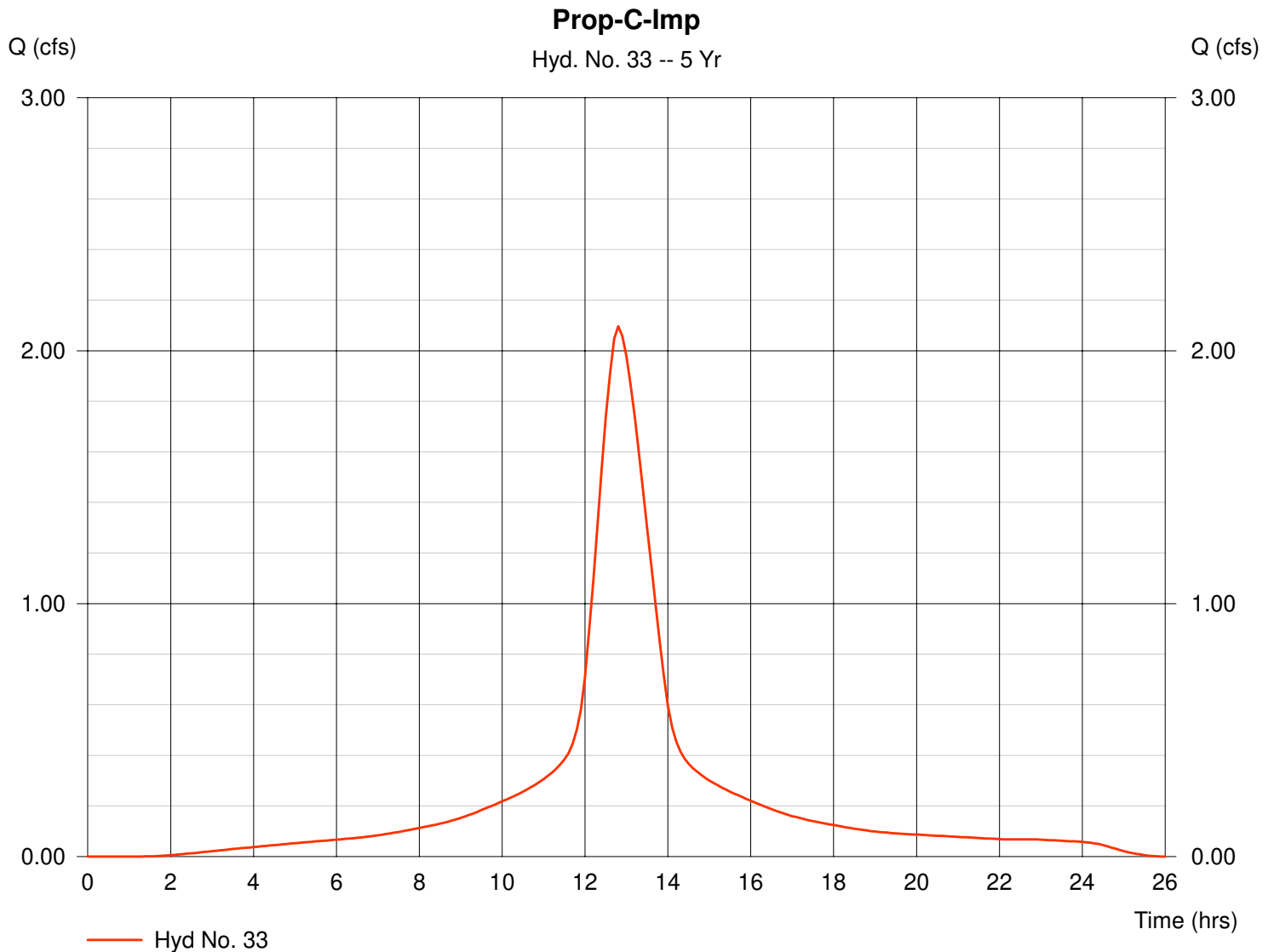

Hydrograph Plot

Hydraflow Hydrographs by Intelisolve

Tuesday, Feb 11 2020, 10:32 AM

Hyd. No. 34

Prop-C-Perv

Hydrograph type = SCS Runoff
Storm frequency = 5 yrs
Drainage area = 133.04 ac
Basin Slope = 0.0 %
Tc method = USER
Total precip. = 4.30 in
Storm duration = 24 hrs

Peak discharge = 1.78 cfs
Time interval = 6 min
Curve number = 40
Hydraulic length = 0 ft
Time of conc. (Tc) = 75.49 min
Distribution = Type III
Shape factor = 484

Hydrograph Volume = 49,278 cuft

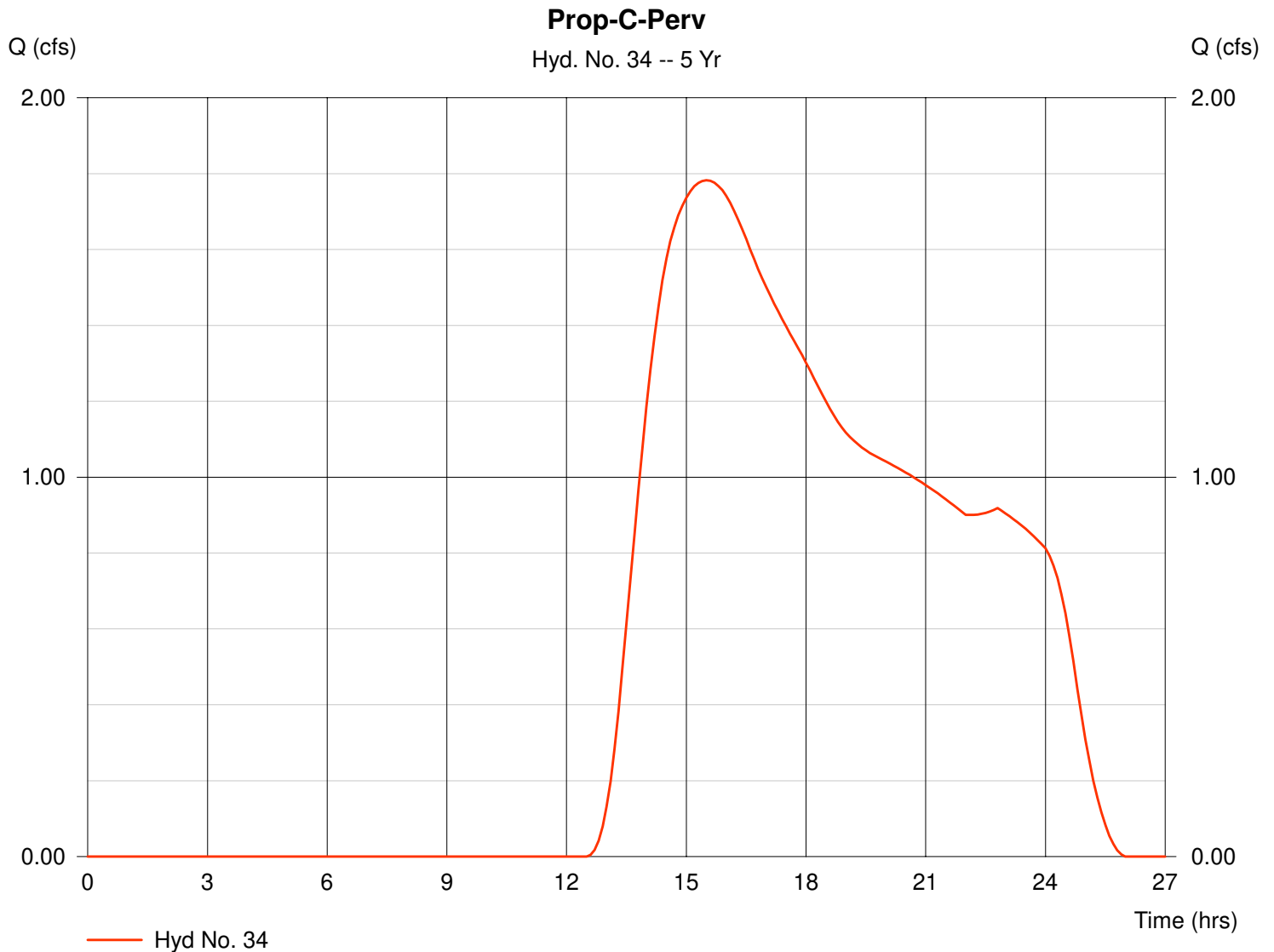

Hydrograph Plot

Hydraflow Hydrographs by Intelisolve

Tuesday, Feb 11 2020, 10:32 AM

Hyd. No. 35

Prop-C

Hydrograph type = Combine
Storm frequency = 5 yrs
Inflow hyds. = 33, 34

Peak discharge = 2.14 cfs
Time interval = 6 min

Hydrograph Volume = 69,901 cuft

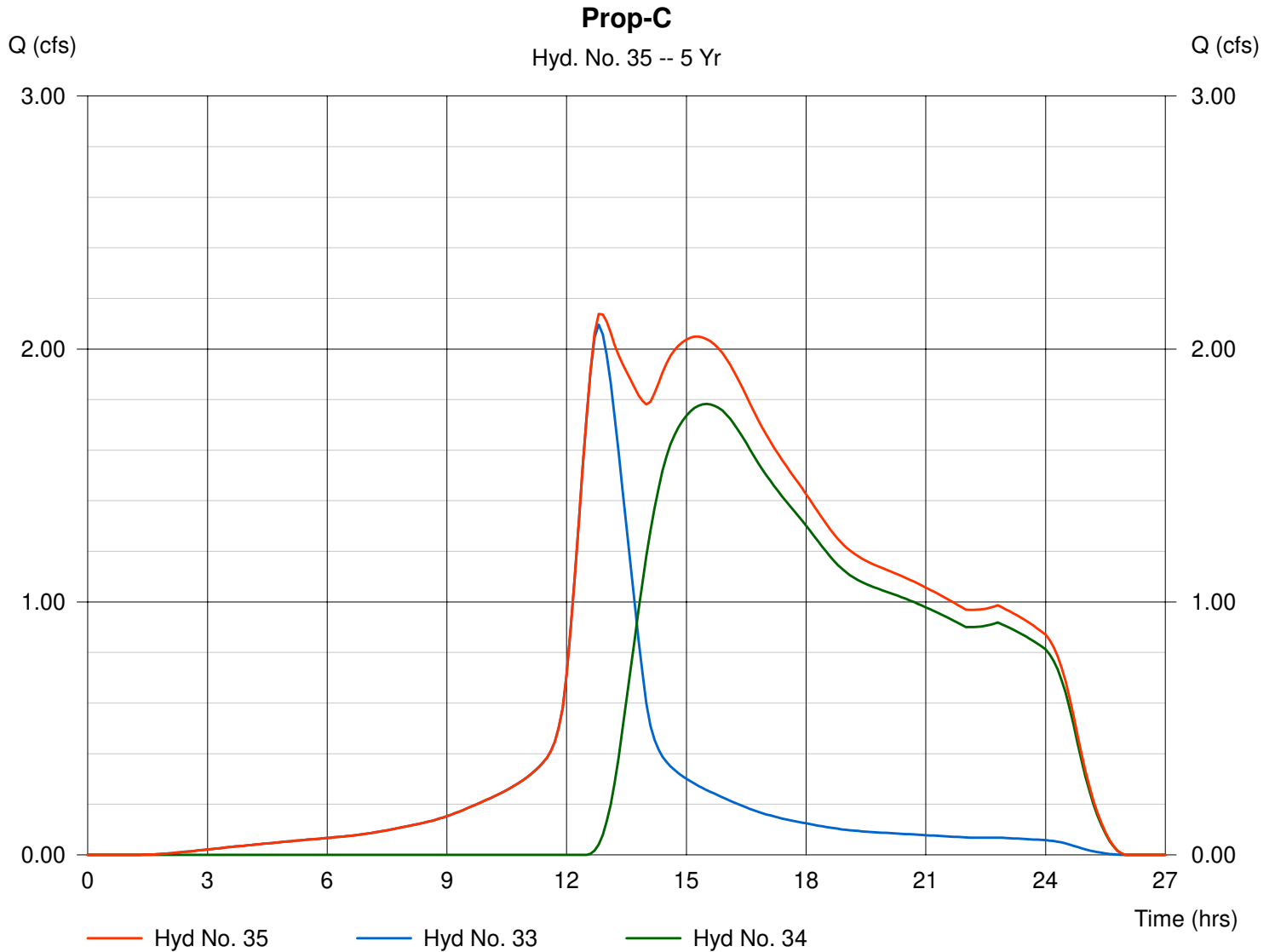

Hydrograph Summary Report

Hyd. No.	Hydrograph type (origin)	Peak flow (cfs)	Time interval (min)	Time to peak (min)	Volume (cuft)	Inflow hyd(s)	Maximum elevation (ft)	Maximum storage (cuft)	Hydrograph description
1	SCS Runoff	4.00	6	780	46,411	---	-----	-----	Exist-A-Imp
2	SCS Runoff	3.62	6	882	92,870	---	-----	-----	Exist-A-Perv
3	Combine	5.70	6	816	139,281	1, 2	-----	-----	Exist-A
5	SCS Runoff	3.85	6	774	41,497	---	-----	-----	Prop-A-Imp
6	SCS Runoff	4.18	6	852	99,628	---	-----	-----	Prop-A-Perv
7	Combine	6.37	6	804	141,125	5, 6	-----	-----	Prop-A
10	SCS Runoff	3.77	6	774	40,629	---	-----	-----	Exist-B-Imp
11	SCS Runoff	0.16	6	1440	2,379	---	-----	-----	Exist-B-Perv
12	Combine	3.77	6	774	43,008	10, 11	-----	-----	Exist-B
14	SCS Runoff	0.19	6	774	2,084	---	-----	-----	Prop-B-Imp
15	SCS Runoff	0.09	6	1386	1,973	---	-----	-----	Prop-B-Perv
17	SCS Runoff	1.01	6	774	10,869	---	-----	-----	Prop-B-Imp-FAN-Basin
18	SCS Runoff	0.28	6	1374	8,193	---	-----	-----	Prop-B-Perv-FAN-Basin
19	Combine	1.01	6	774	19,062	17, 18	-----	-----	FAN Basin Inflow
20	Reservoir	0.20	6	1482	15,924	19	154.63	13,962	FAN Basin 1 Routing
21	SCS Runoff	0.32	6	774	3,473	---	-----	-----	Prop-B-Imp-ROCA-Basin
22	SCS Runoff	0.25	6	888	6,682	---	-----	-----	Prop-B-Perv-ROCA-Basin
23	Combine	0.39	6	798	10,155	21, 22	-----	-----	ROCA Basin Inflow
24	Reservoir	0.22	6	1032	9,028	23	154.89	4,106	ROCA Basin Routing
25	Combine	0.19	6	774	4,057	14, 15,	-----	-----	Prop-B
26	Combine	0.42	6	1422	29,009	20, 24, 25	-----	-----	Prop-B
29	SCS Runoff	2.87	6	768	28,372	---	-----	-----	Exist-C-Imp
30	SCS Runoff	4.79	6	840	111,760	---	-----	-----	Exist-C-Perv
31	Combine	6.16	6	810	140,131	29, 30	-----	-----	Exist-C

Hydrograph Summary Report

Hyd. No.	Hydrograph type (origin)	Peak flow (cfs)	Time interval (min)	Time to peak (min)	Volume (cuft)	Inflow hyd(s)	Maximum elevation (ft)	Maximum storage (cuft)	Hydrograph description
33	SCS Runoff	2.45	6	768	24,270	---	-----	-----	Prop-C-Imp
34	SCS Runoff	4.88	6	840	113,822	---	-----	-----	Prop-C-Perv
35	Combine	5.99	6	810	138,091	33, 34	-----	-----	Prop-C

Hydrograph Plot

Hydraflow Hydrographs by Intelisolve

Tuesday, Feb 11 2020, 10:32 AM

Hyd. No. 1

Exist-A-Imp

Hydrograph type = SCS Runoff
 Storm frequency = 10 yrs
 Drainage area = 2.64 ac
 Basin Slope = 0.0 %
 Tc method = USER
 Total precip. = 5.02 in
 Storm duration = 24 hrs

Peak discharge = 4.00 cfs
 Time interval = 6 min
 Curve number = 98
 Hydraulic length = 0 ft
 Time of conc. (Tc) = 91.29 min
 Distribution = Type III
 Shape factor = 484

Hydrograph Volume = 46,411 cuft

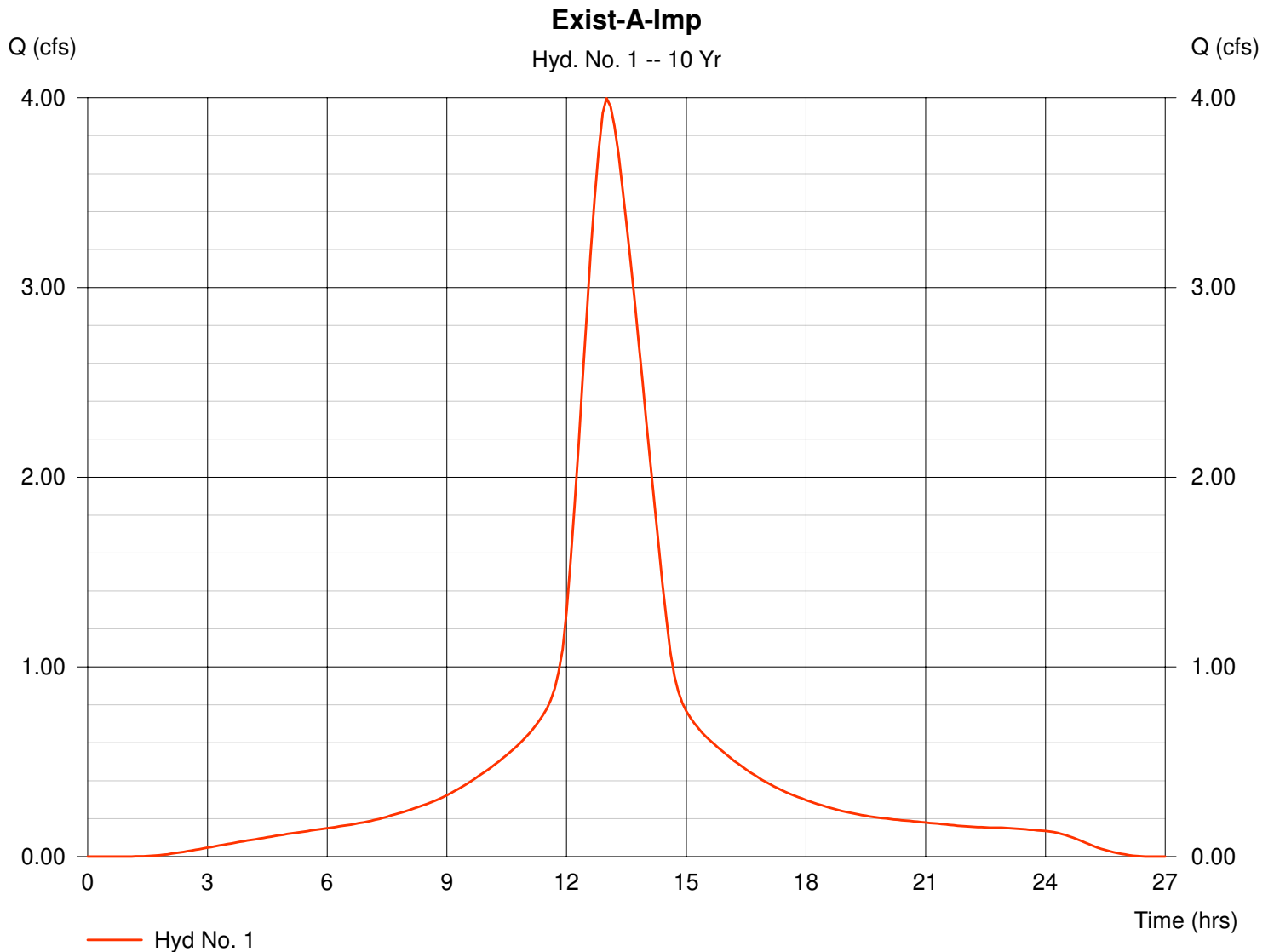

Hydrograph Plot

Hydraflow Hydrographs by Intelisolve

Tuesday, Feb 11 2020, 10:32 AM

Hyd. No. 2

Exist-A-Perv

Hydrograph type = SCS Runoff
Storm frequency = 10 yrs
Drainage area = 123.80 ac
Basin Slope = 0.0 %
Tc method = USER
Total precip. = 5.02 in
Storm duration = 24 hrs

Peak discharge = 3.62 cfs
Time interval = 6 min
Curve number = 39
Hydraulic length = 0 ft
Time of conc. (Tc) = 91.29 min
Distribution = Type III
Shape factor = 484

Hydrograph Volume = 92,870 cuft

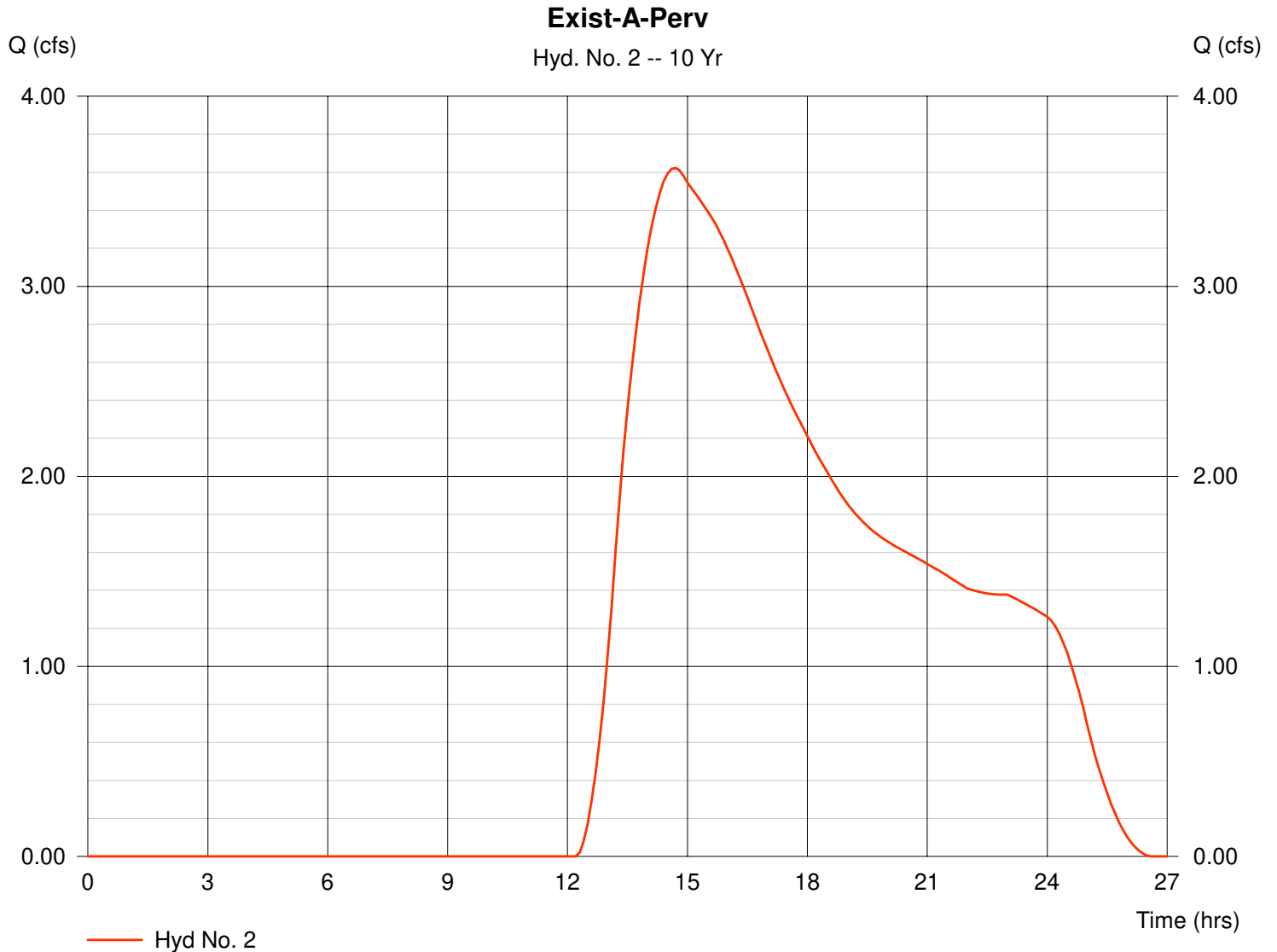

Hydrograph Plot

Hydraflow Hydrographs by Intelisolve

Tuesday, Feb 11 2020, 10:32 AM

Hyd. No. 3

Exist-A

Hydrograph type = Combine
Storm frequency = 10 yrs
Inflow hyds. = 1, 2

Peak discharge = 5.70 cfs
Time interval = 6 min

Hydrograph Volume = 139,281 cuft

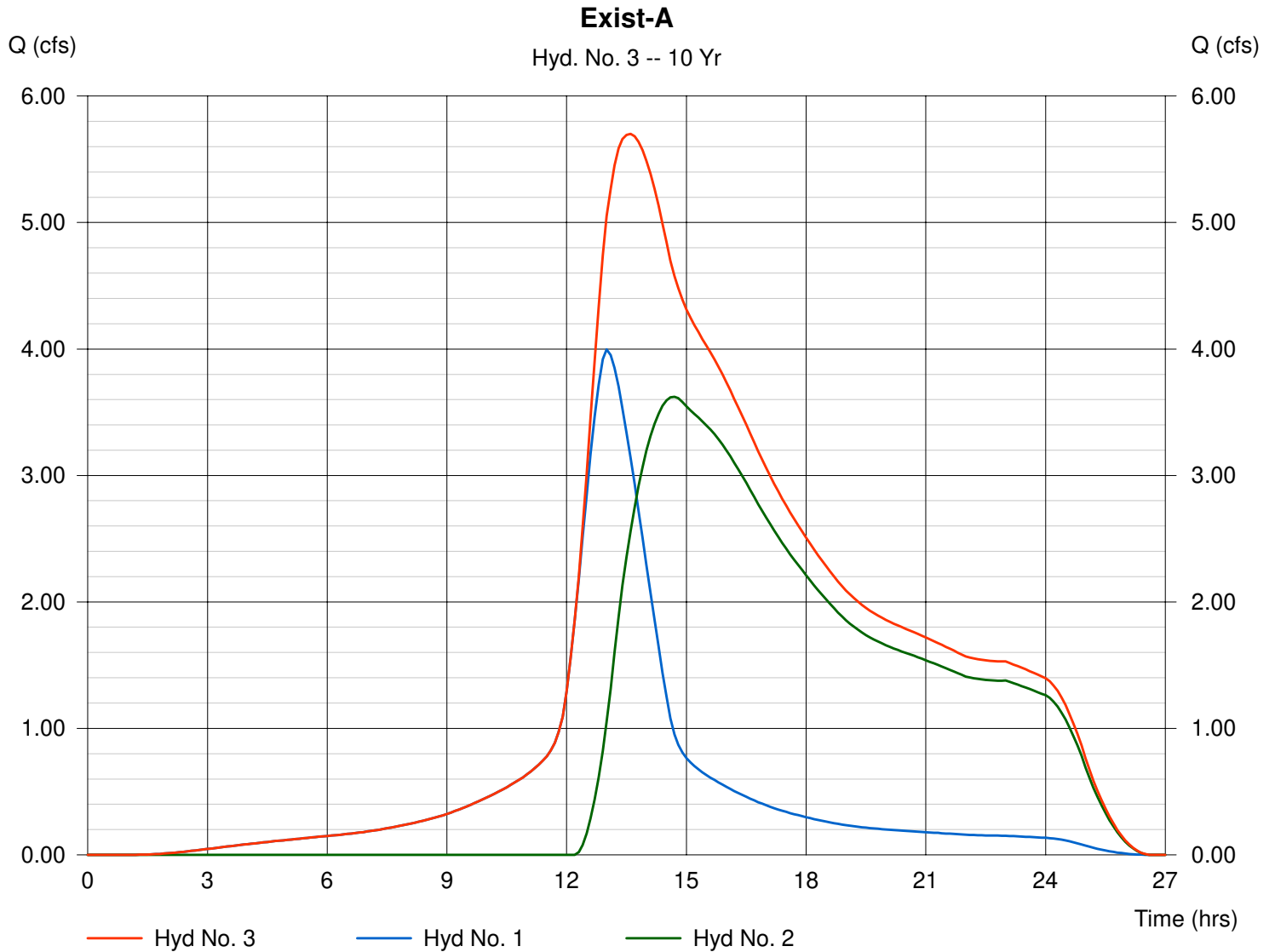

Hydrograph Plot

Hydraflow Hydrographs by Intelisolve

Tuesday, Feb 11 2020, 10:32 AM

Hyd. No. 5

Prop-A-Imp

Hydrograph type = SCS Runoff
Storm frequency = 10 yrs
Drainage area = 2.39 ac
Basin Slope = 0.0 %
Tc method = USER
Total precip. = 5.02 in
Storm duration = 24 hrs

Peak discharge = 3.85 cfs
Time interval = 6 min
Curve number = 98
Hydraulic length = 0 ft
Time of conc. (Tc) = 90.72 min
Distribution = Type III
Shape factor = 484

Hydrograph Volume = 41,497 cuft

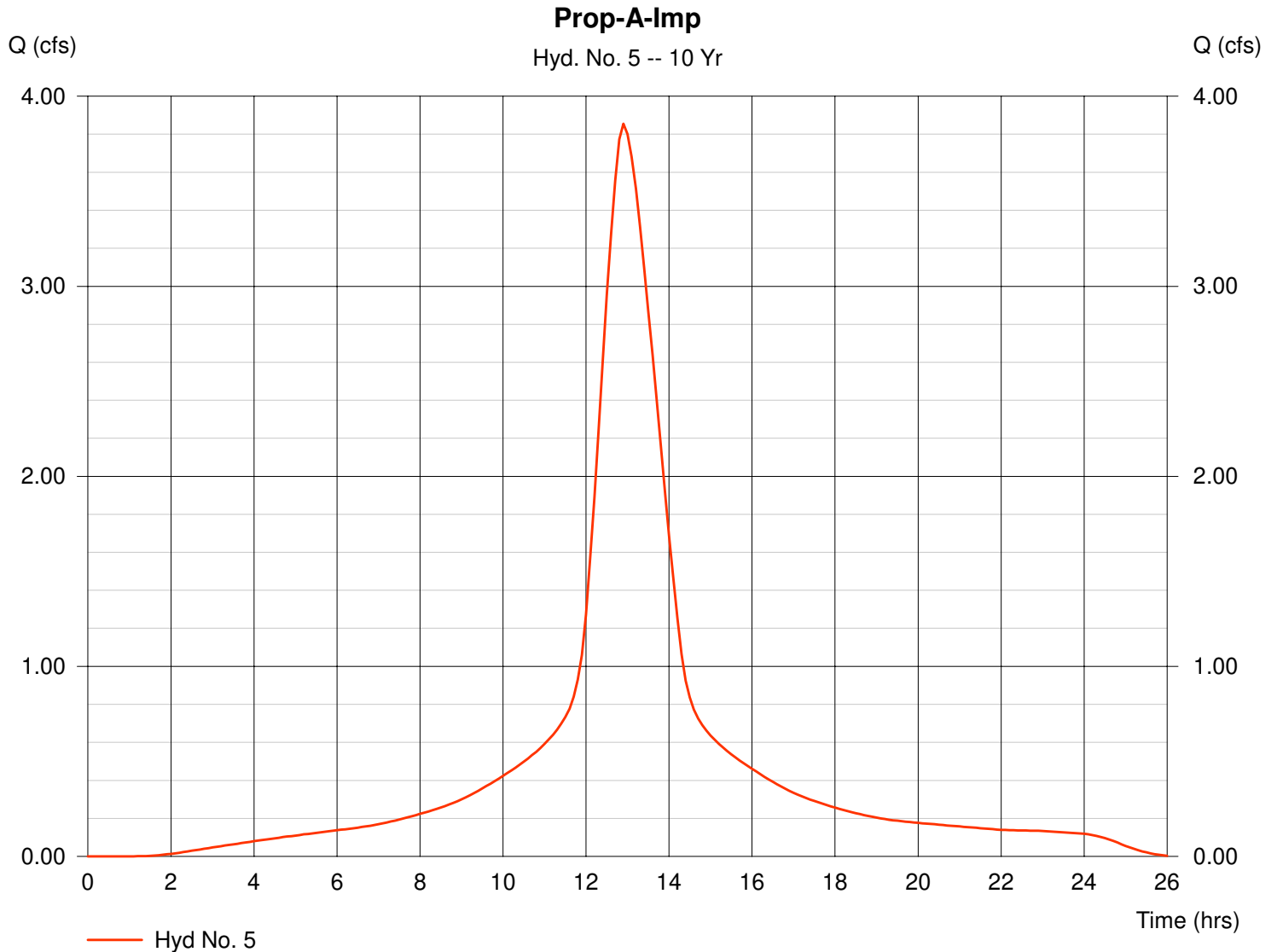

Hydrograph Plot

Hydraflow Hydrographs by Intelisolve

Tuesday, Feb 11 2020, 10:32 AM

Hyd. No. 6

Prop-A-Perv

Hydrograph type = SCS Runoff
Storm frequency = 10 yrs
Drainage area = 114.63 ac
Basin Slope = 0.0 %
Tc method = USER
Total precip. = 5.02 in
Storm duration = 24 hrs

Peak discharge = 4.18 cfs
Time interval = 6 min
Curve number = 40
Hydraulic length = 0 ft
Time of conc. (Tc) = 90.7 min
Distribution = Type III
Shape factor = 484

Hydrograph Volume = 99,628 cuft

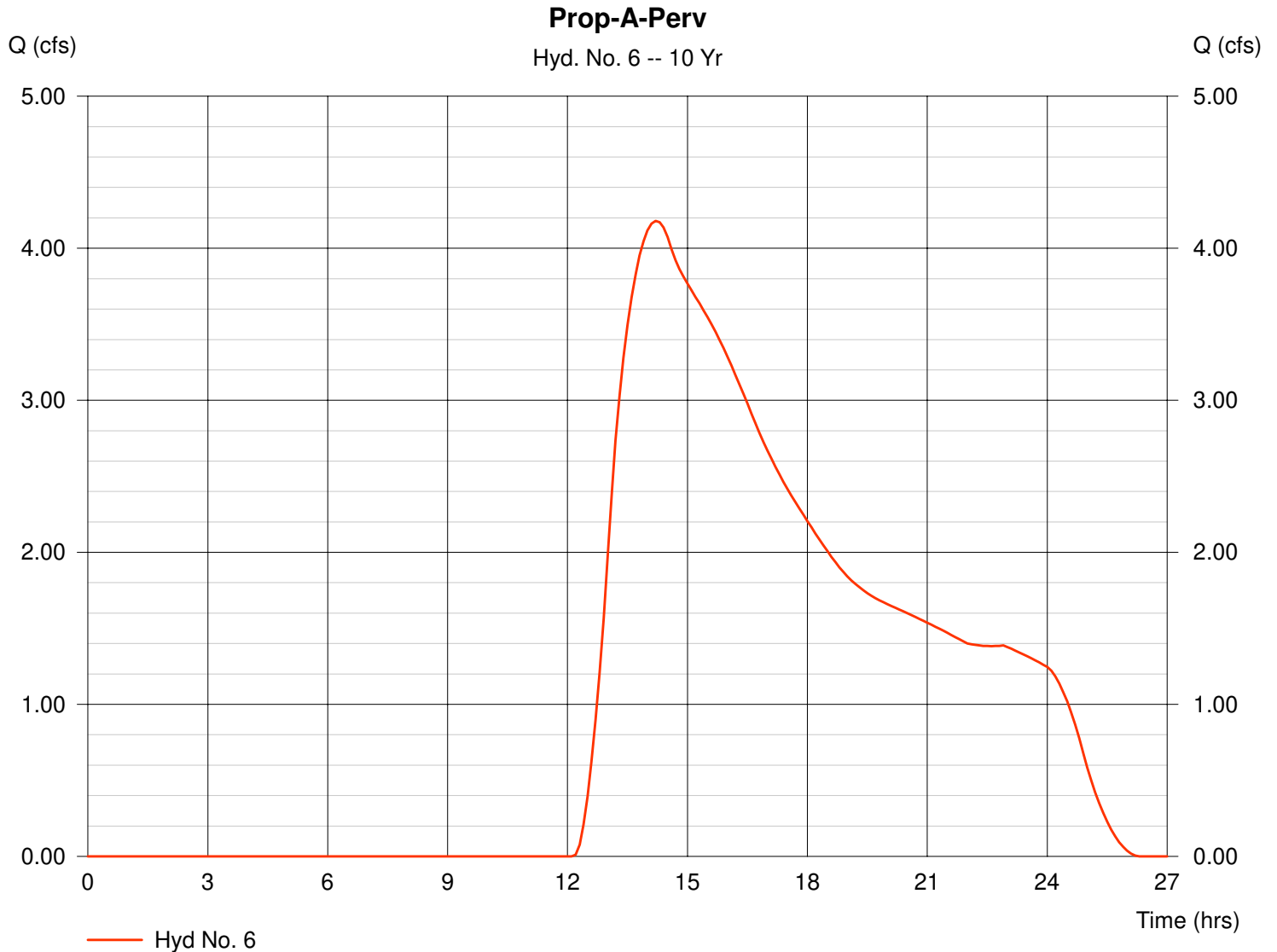

Hydrograph Plot

Hydraflow Hydrographs by Intelisolve

Tuesday, Feb 11 2020, 10:32 AM

Hyd. No. 7

Prop-A

Hydrograph type = Combine
Storm frequency = 10 yrs
Inflow hyds. = 5, 6

Peak discharge = 6.37 cfs
Time interval = 6 min

Hydrograph Volume = 141,125 cuft

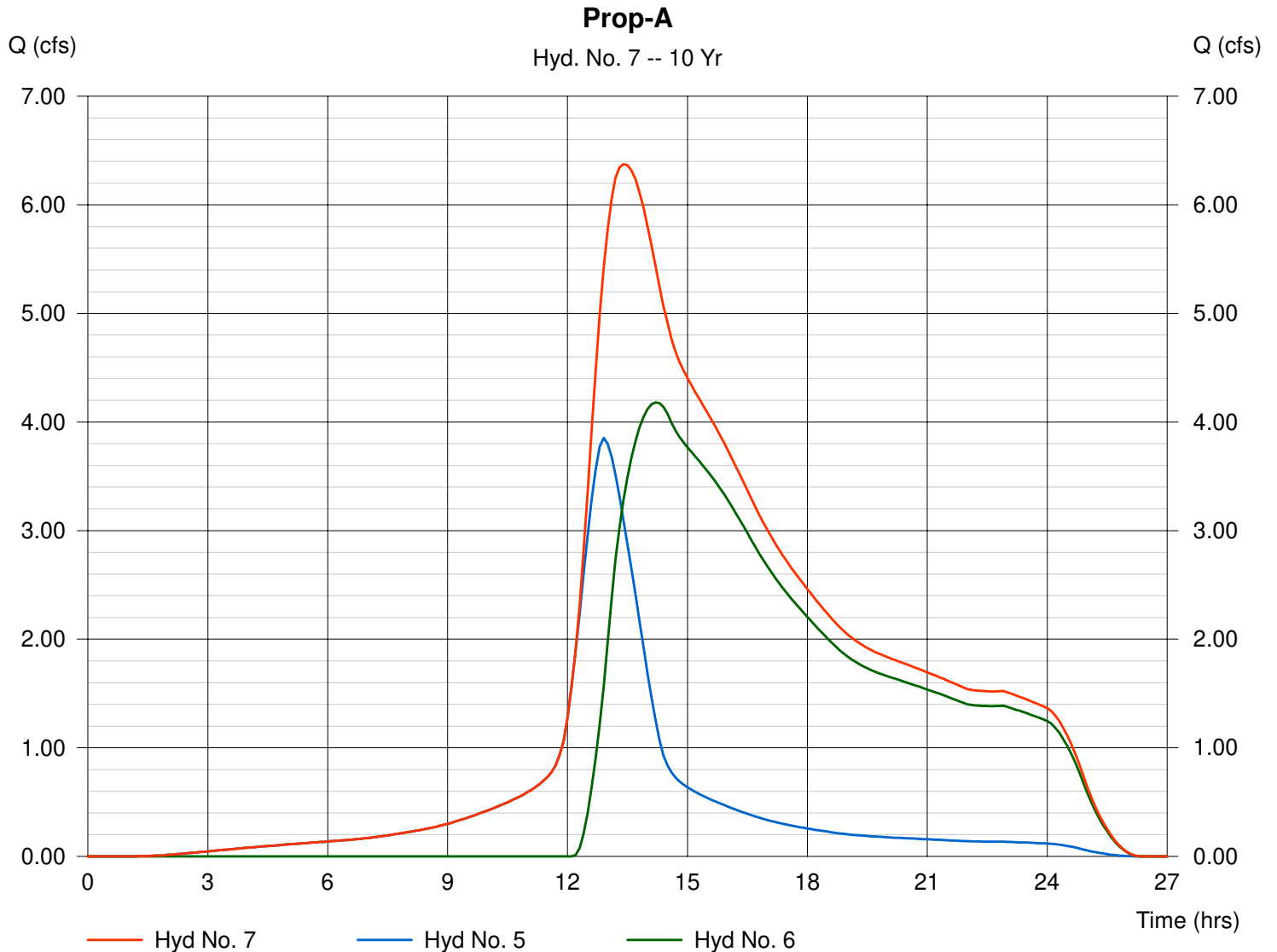

Hydrograph Plot

Hydraflow Hydrographs by Intelisolve

Tuesday, Feb 11 2020, 10:32 AM

Hyd. No. 10

Exist-B-Imp

Hydrograph type = SCS Runoff
Storm frequency = 10 yrs
Drainage area = 2.34 ac
Basin Slope = 0.0 %
Tc method = USER
Total precip. = 5.02 in
Storm duration = 24 hrs

Peak discharge = 3.77 cfs
Time interval = 6 min
Curve number = 98
Hydraulic length = 0 ft
Time of conc. (Tc) = 87.72 min
Distribution = Type III
Shape factor = 484

Hydrograph Volume = 40,629 cuft

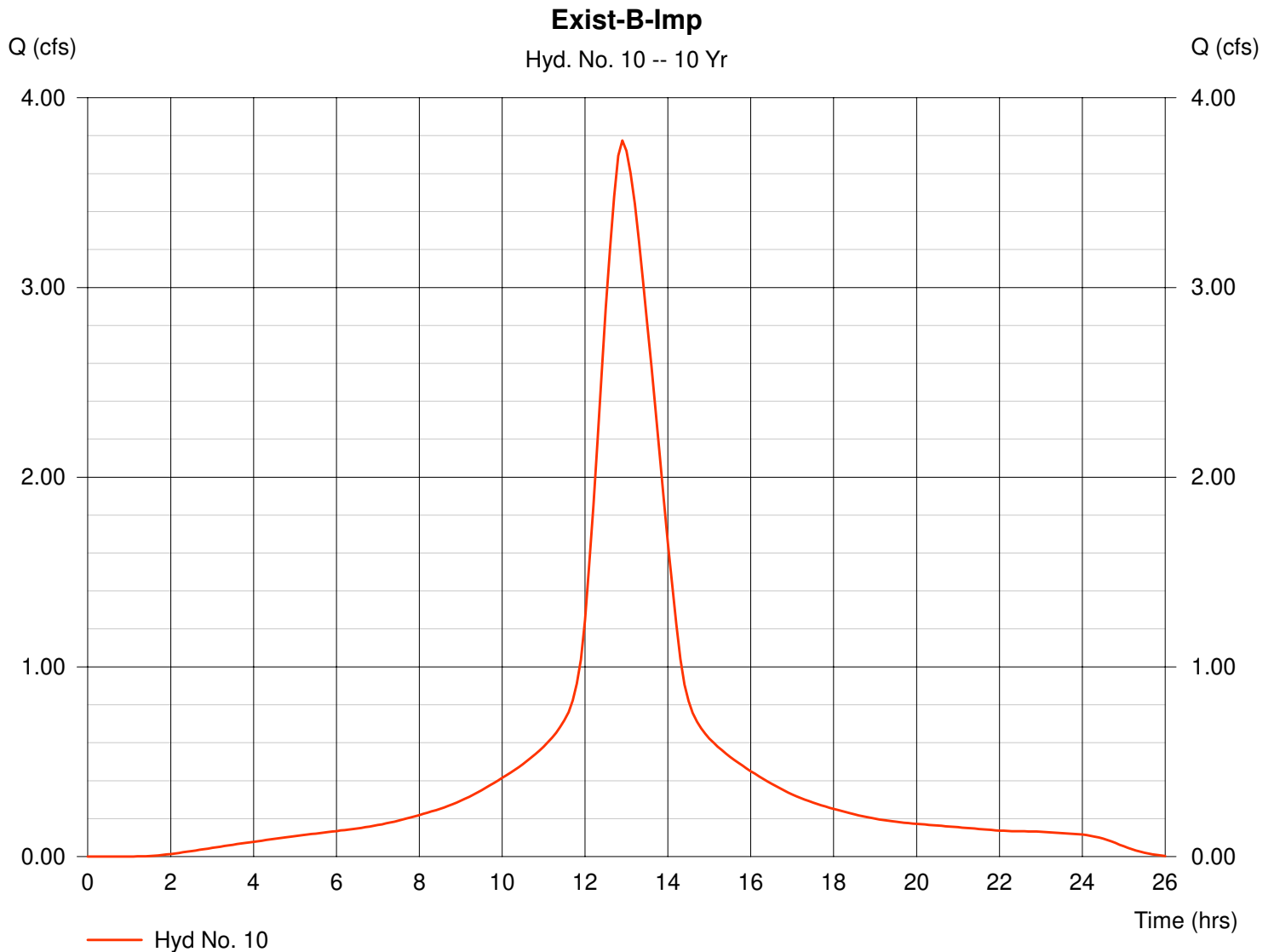

Hydrograph Plot

Hydraflow Hydrographs by Intelisolve

Tuesday, Feb 11 2020, 10:32 AM

Hyd. No. 11

Exist-B-Perv

Hydrograph type = SCS Runoff
 Storm frequency = 10 yrs
 Drainage area = 124.34 ac
 Basin Slope = 0.0 %
 Tc method = USER
 Total precip. = 5.02 in
 Storm duration = 24 hrs

Peak discharge = 0.16 cfs
 Time interval = 6 min
 Curve number = 30
 Hydraulic length = 0 ft
 Time of conc. (Tc) = 87.7 min
 Distribution = Type III
 Shape factor = 484

Hydrograph Volume = 2,379 cuft

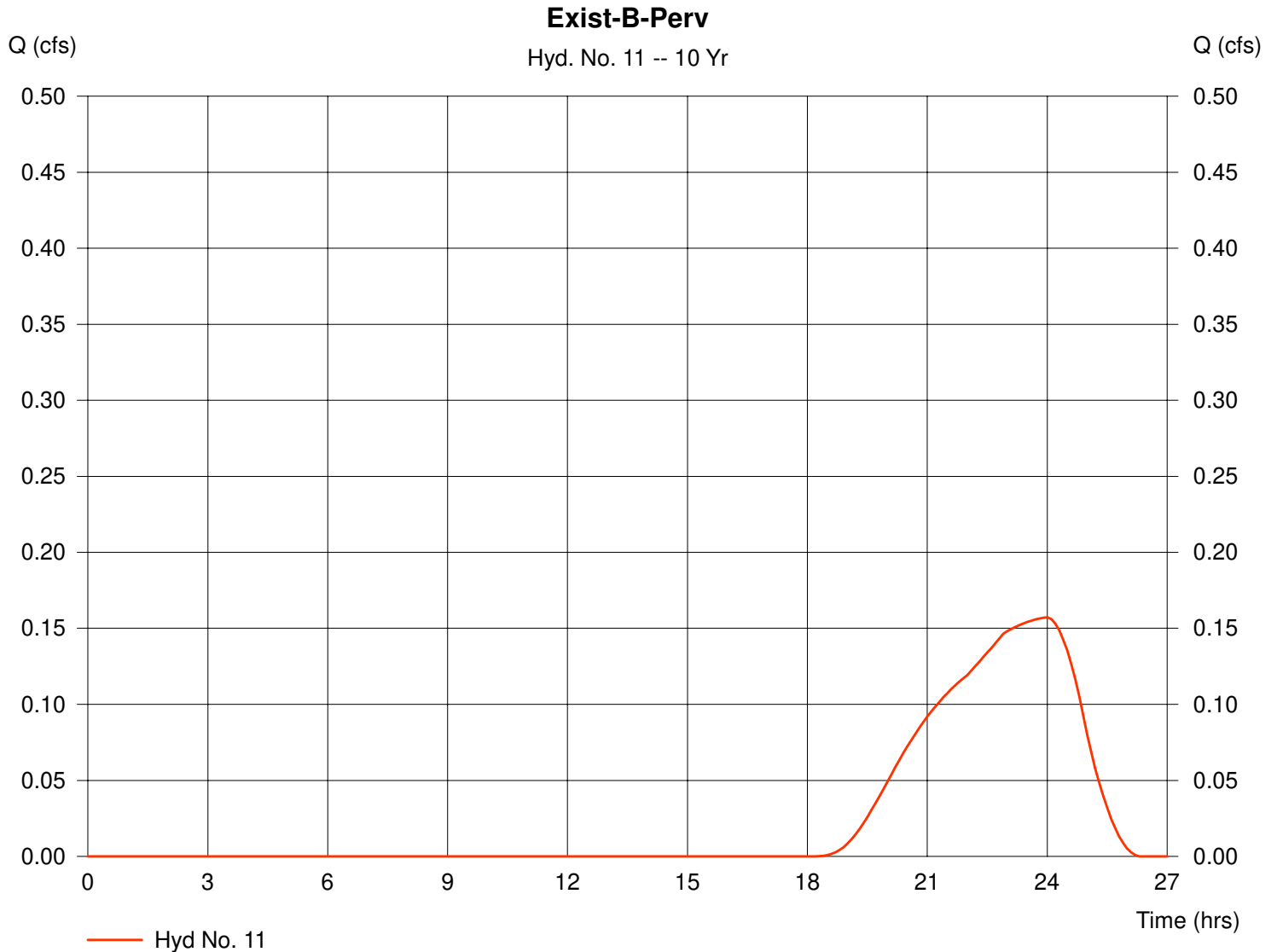

Hydrograph Plot

Hydraflow Hydrographs by Intelisolve

Tuesday, Feb 11 2020, 10:32 AM

Hyd. No. 12

Exist-B

Hydrograph type = Combine
Storm frequency = 10 yrs
Inflow hyds. = 10, 11

Peak discharge = 3.77 cfs
Time interval = 6 min

Hydrograph Volume = 43,008 cuft

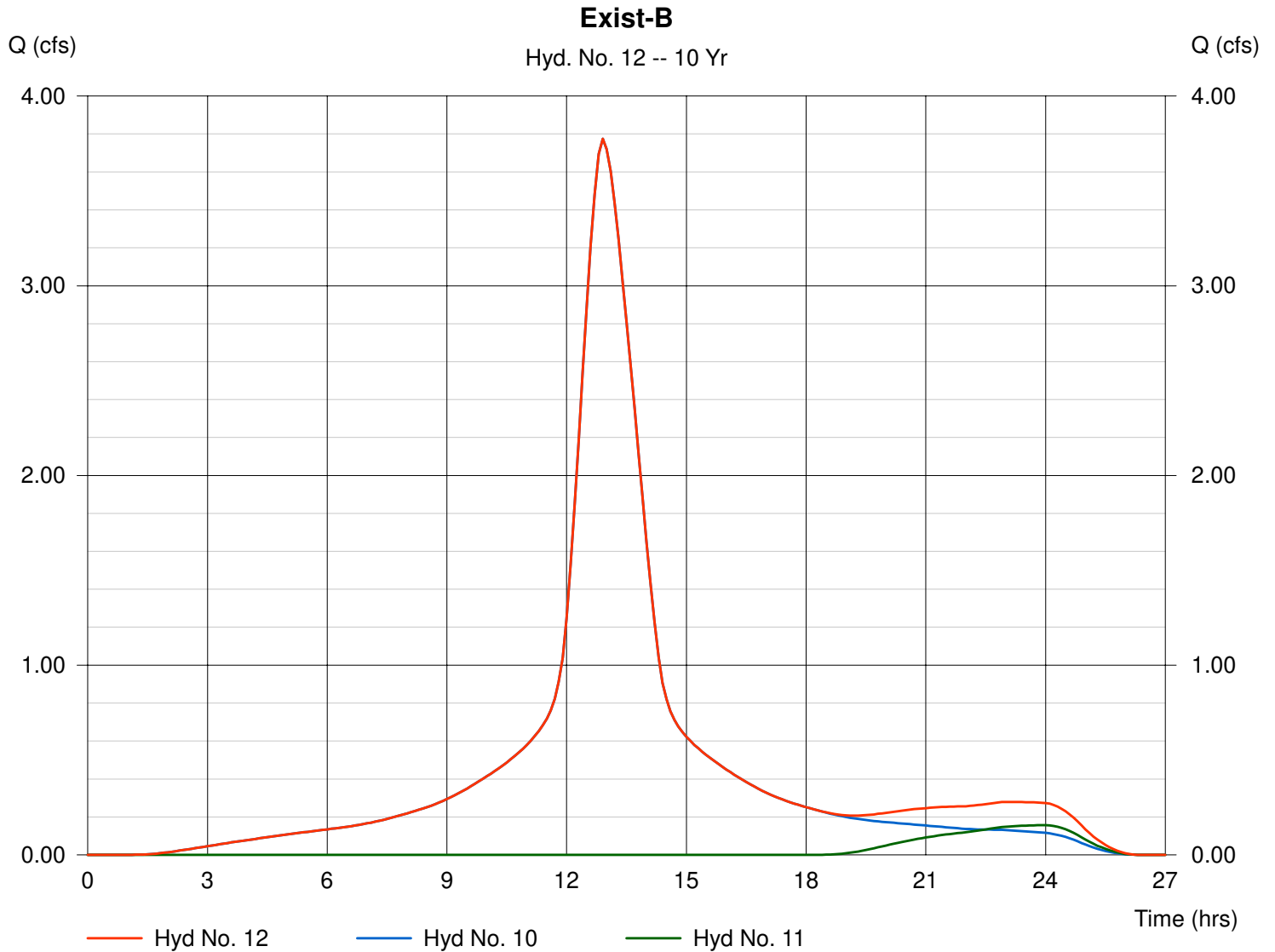

Hydrograph Plot

Hydraflow Hydrographs by Intelisolve

Tuesday, Feb 11 2020, 10:32 AM

Hyd. No. 14

Prop-B-Imp

Hydrograph type = SCS Runoff
Storm frequency = 10 yrs
Drainage area = 0.12 ac
Basin Slope = 0.0 %
Tc method = USER
Total precip. = 5.02 in
Storm duration = 24 hrs

Peak discharge = 0.19 cfs
Time interval = 6 min
Curve number = 98
Hydraulic length = 0 ft
Time of conc. (Tc) = 82.7 min
Distribution = Type III
Shape factor = 484

Hydrograph Volume = 2,084 cuft

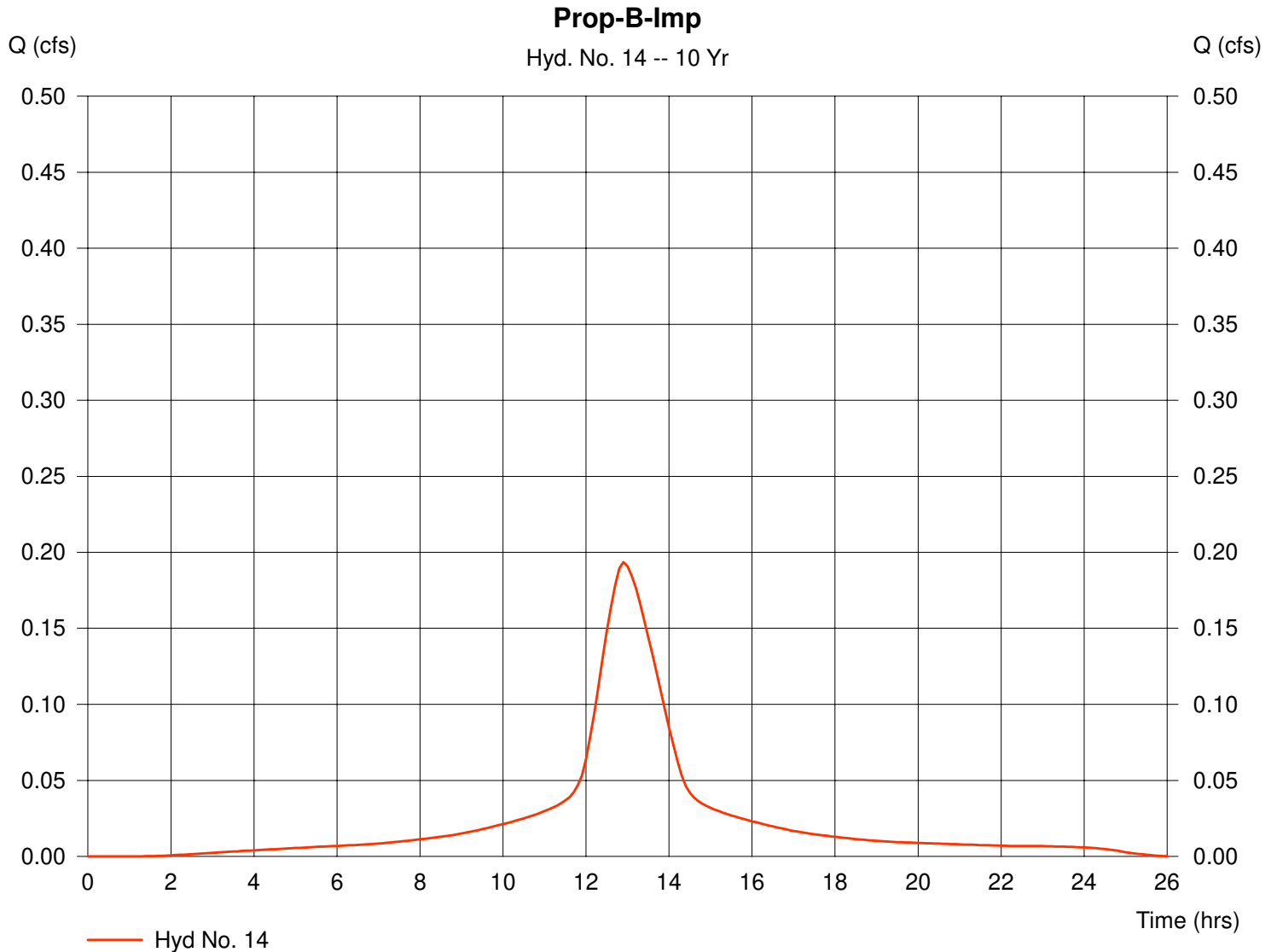

Hydrograph Plot

Hydraflow Hydrographs by Intelisolve

Tuesday, Feb 11 2020, 10:32 AM

Hyd. No. 15

Prop-B-Perv

Hydrograph type = SCS Runoff
Storm frequency = 10 yrs
Drainage area = 38.41 ac
Basin Slope = 0.0 %
Tc method = USER
Total precip. = 5.02 in
Storm duration = 24 hrs

Peak discharge = 0.09 cfs
Time interval = 6 min
Curve number = 31
Hydraulic length = 0 ft
Time of conc. (Tc) = 82.7 min
Distribution = Type III
Shape factor = 484

Hydrograph Volume = 1,973 cuft

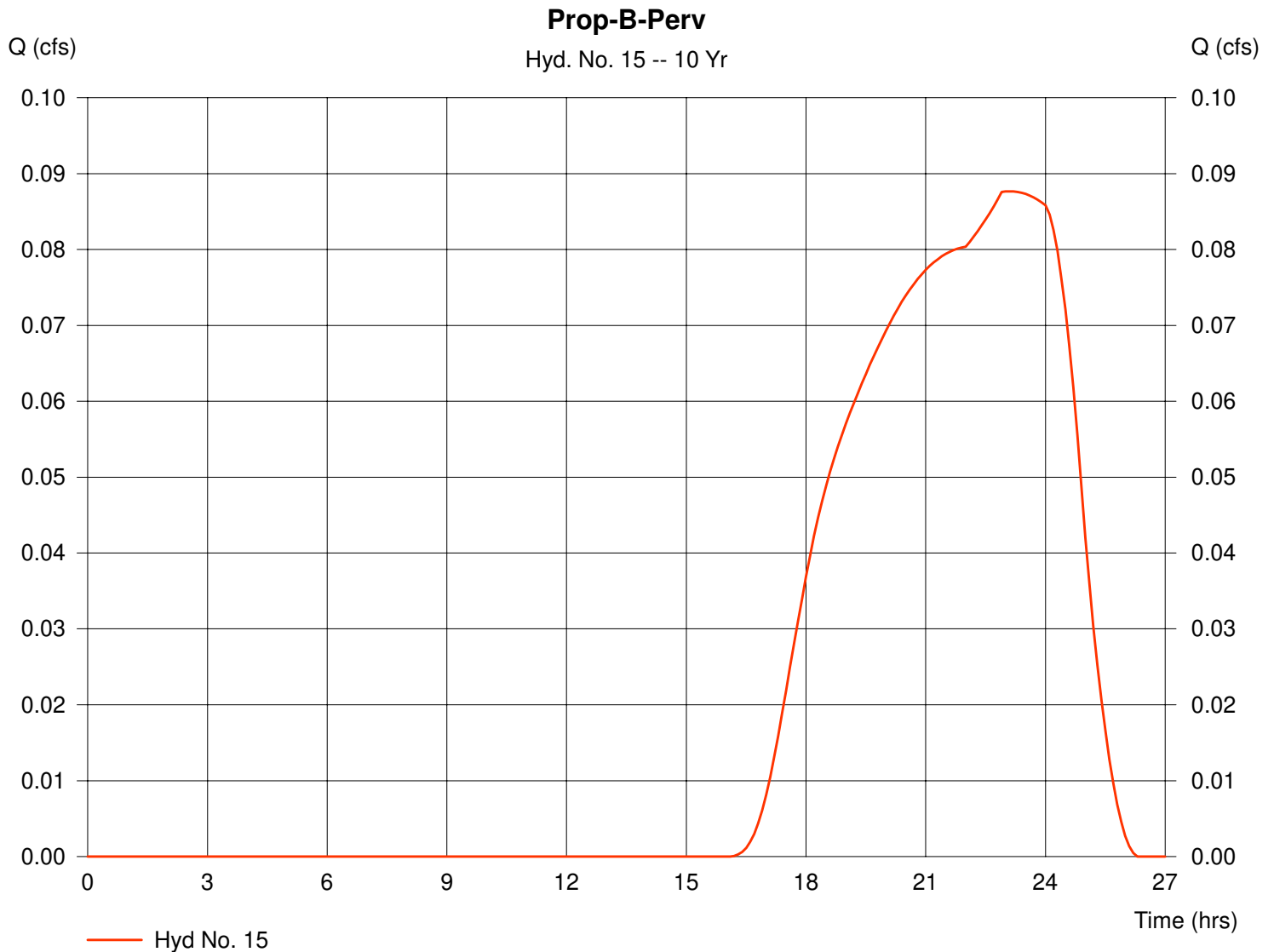

Hydrograph Plot

Hydraflow Hydrographs by Intelisolve

Tuesday, Feb 11 2020, 10:32 AM

Hyd. No. 17

Prop-B-Imp-FAN-Basin

Hydrograph type = SCS Runoff
 Storm frequency = 10 yrs
 Drainage area = 0.63 ac
 Basin Slope = 0.0 %
 Tc method = USER
 Total precip. = 5.02 in
 Storm duration = 24 hrs

Peak discharge = 1.01 cfs
 Time interval = 6 min
 Curve number = 98
 Hydraulic length = 0 ft
 Time of conc. (Tc) = 82.7 min
 Distribution = Type III
 Shape factor = 484

Hydrograph Volume = 10,869 cuft

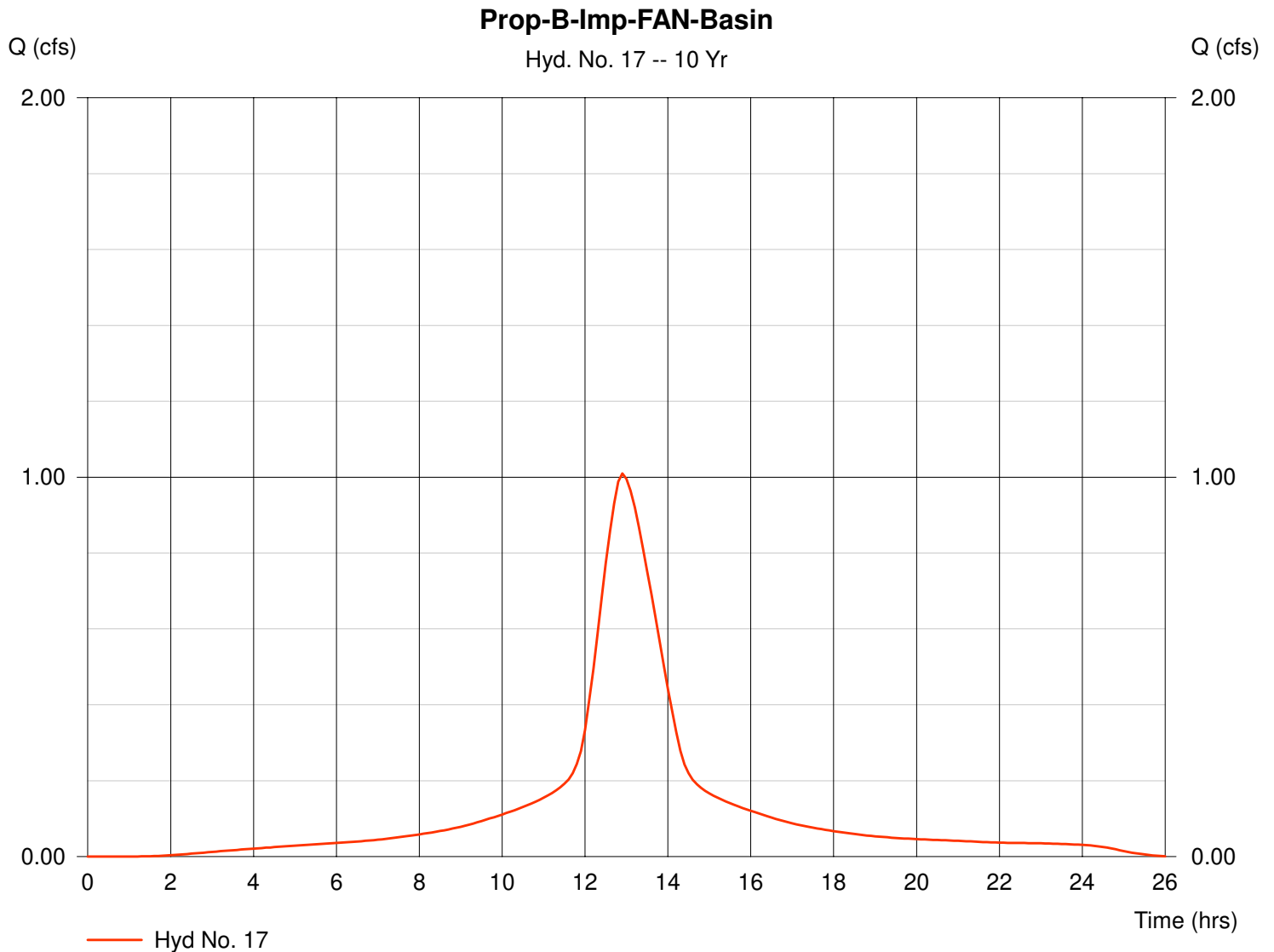

Hydrograph Plot

Hydraflow Hydrographs by Intelisolve

Tuesday, Feb 11 2020, 10:32 AM

Hyd. No. 18

Prop-B-Perv-FAN-Basin

Hydrograph type = SCS Runoff
Storm frequency = 10 yrs
Drainage area = 83.82 ac
Basin Slope = 0.0 %
Tc method = USER
Total precip. = 5.02 in
Storm duration = 24 hrs

Peak discharge = 0.28 cfs
Time interval = 6 min
Curve number = 32
Hydraulic length = 0 ft
Time of conc. (Tc) = 82.7 min
Distribution = Type III
Shape factor = 484

Hydrograph Volume = 8,193 cuft

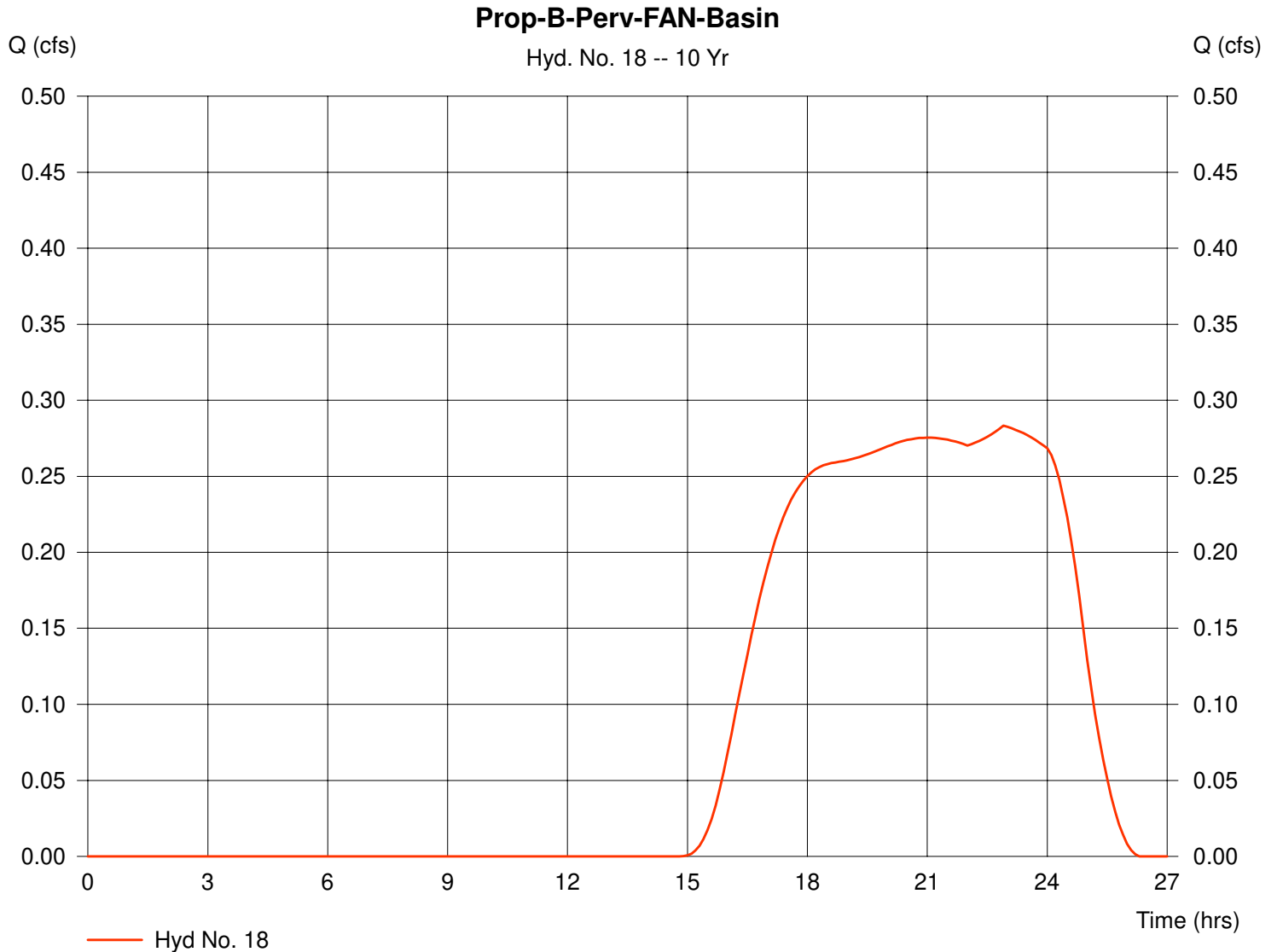

Hydrograph Plot

Hydraflow Hydrographs by Intelisolve

Tuesday, Feb 11 2020, 10:32 AM

Hyd. No. 19

FAN Basin Inflow

Hydrograph type = Combine
Storm frequency = 10 yrs
Inflow hyds. = 17, 18

Peak discharge = 1.01 cfs
Time interval = 6 min

Hydrograph Volume = 19,062 cuft

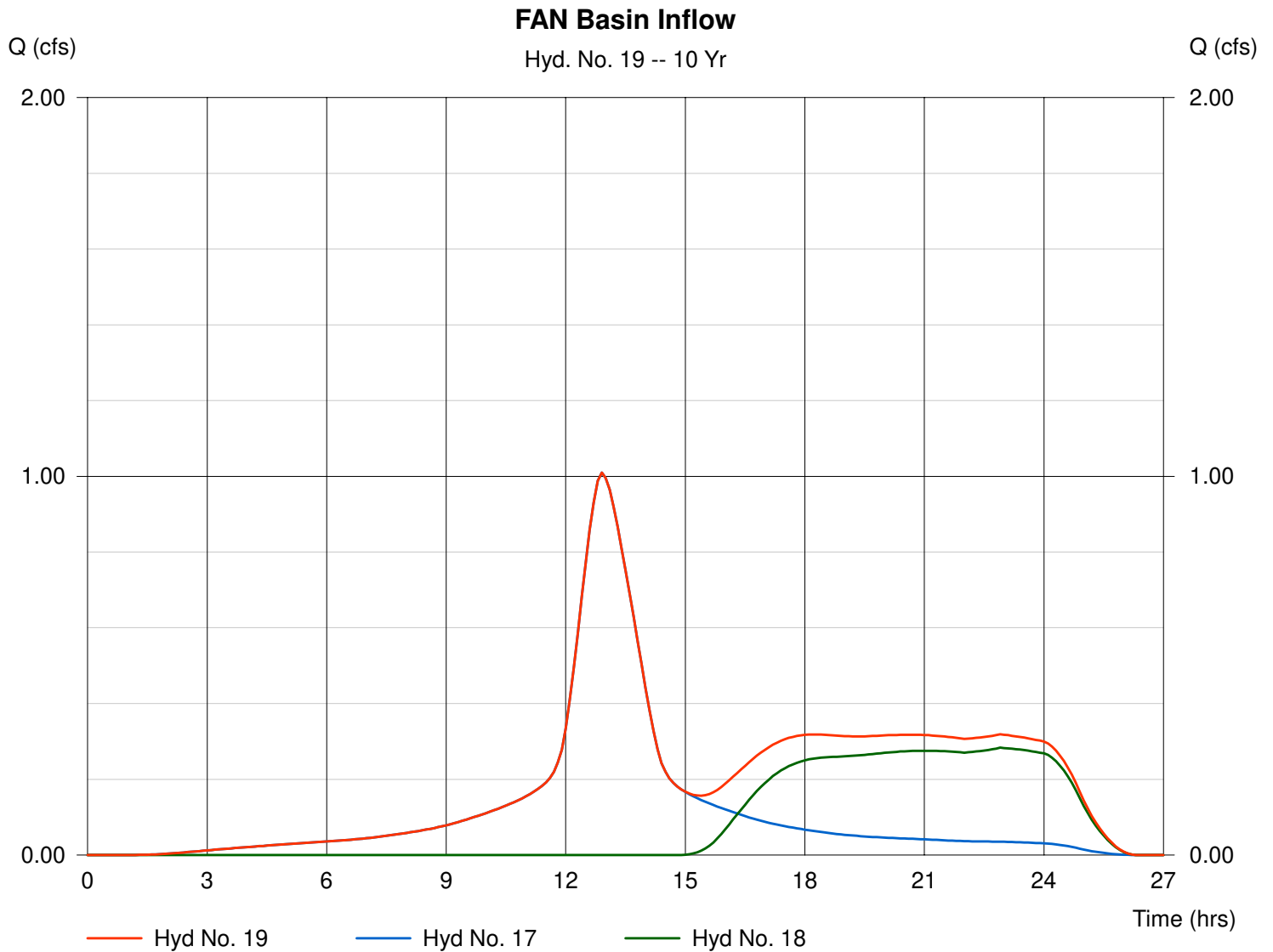

Hydrograph Plot

Hydraflow Hydrographs by Intelisolve

Tuesday, Feb 11 2020, 10:32 AM

Hyd. No. 20

FAN Basin 1 Routing

Hydrograph type = Reservoir
Storm frequency = 10 yrs
Inflow hyd. No. = 19
Reservoir name = FAN Basin

Peak discharge = 0.20 cfs
Time interval = 6 min
Max. Elevation = 154.63 ft
Max. Storage = 13,962 cuft

Storage Indication method used.

Hydrograph Volume = 15,924 cuft

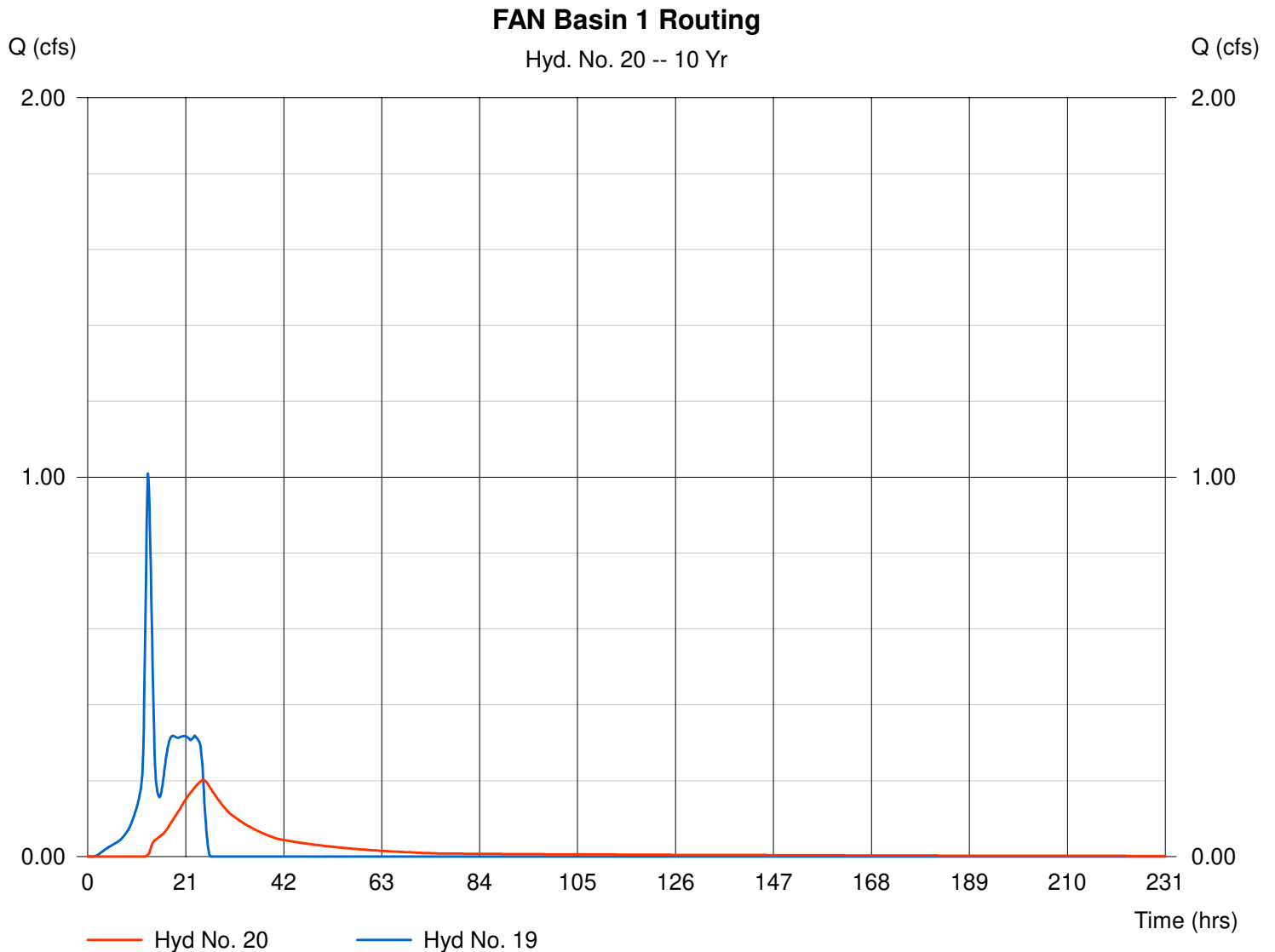

Pond Report

Hydraflow Hydrographs by Intelisolve

Tuesday, Feb 11 2020, 10:32 AM

Pond No. 1 - FAN Basin

Pond Data

Pond storage is based on known contour areas. Average end area method used.

Stage / Storage Table

Stage (ft)	Elevation (ft)	Contour area (sqft)	Incr. Storage (cuft)	Total storage (cuft)
0.00	154.25	36,091	0	0
0.75	155.00	38,058	27,806	27,806
1.75	156.00	40,796	39,427	67,233
2.75	157.00	43,656	42,226	109,459

Culvert / Orifice Structures

	[A]	[B]	[C]	[D]
Rise (in)	= 18.00	6.00	0.00	0.00
Span (in)	= 18.00	6.00	0.00	0.00
No. Barrels	= 1	1	0	0
Invert El. (ft)	= 154.25	154.35	0.00	0.00
Length (ft)	= 38.00	0.00	0.00	0.00
Slope (%)	= 3.30	0.00	0.00	0.00
N-Value	= .013	.013	.013	.000
Orif. Coeff.	= 0.60	0.60	0.60	0.00
Multi-Stage	= n/a	Yes	No	No

Weir Structures

	[A]	[B]	[C]	[D]
Crest Len (ft)	= 16.00	2.00	0.00	0.00
Crest El. (ft)	= 156.50	156.00	0.00	0.00
Weir Coeff.	= 3.33	3.33	3.33	0.00
Weir Type	= Riser	Rect	---	---
Multi-Stage	= Yes	Yes	No	No

Exfiltration = 0.000 in/hr (Contour) Tailwater Elev. = 0.00 ft

Note: Culvert/Orifice outflows have been analyzed under inlet and outlet control.

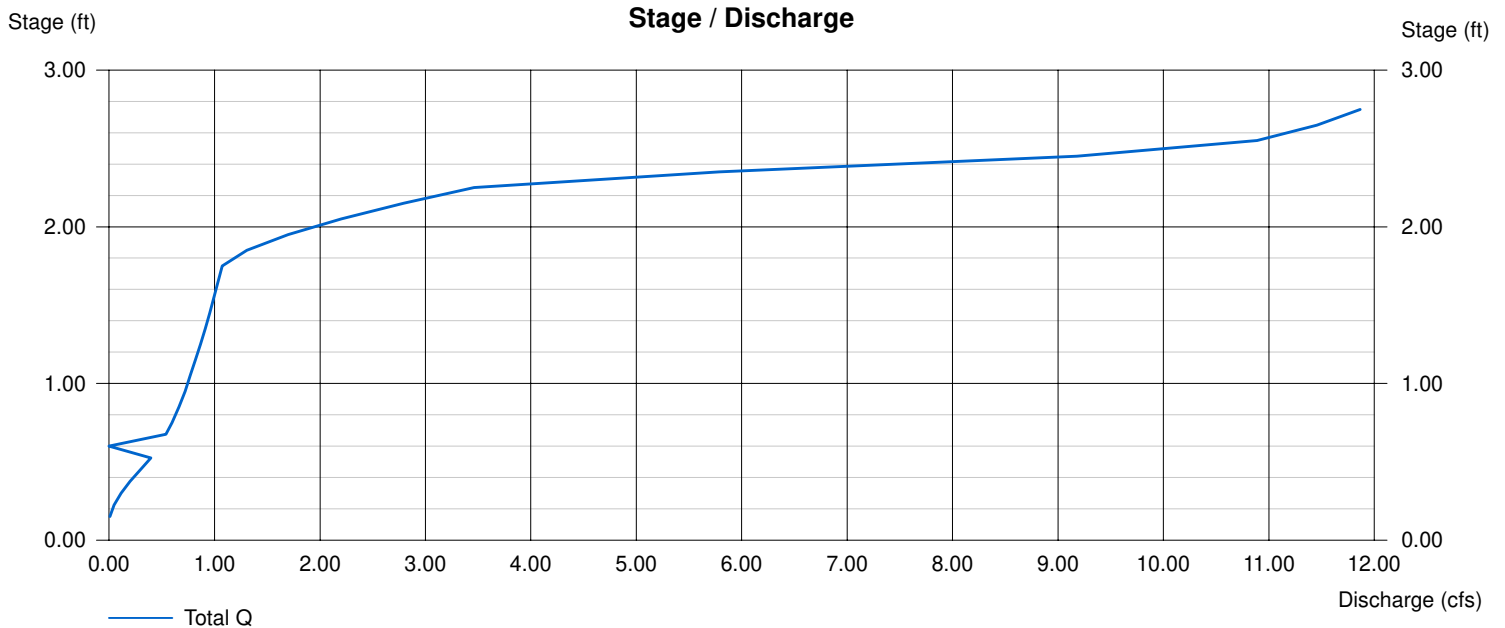

Hydrograph Plot

Hydraflow Hydrographs by Intelisolve

Tuesday, Feb 11 2020, 10:32 AM

Hyd. No. 21

Prop-B-Imp-ROCA-Basin

Hydrograph type = SCS Runoff
 Storm frequency = 10 yrs
 Drainage area = 0.20 ac
 Basin Slope = 0.0 %
 Tc method = USER
 Total precip. = 5.02 in
 Storm duration = 24 hrs

Peak discharge = 0.32 cfs
 Time interval = 6 min
 Curve number = 98
 Hydraulic length = 0 ft
 Time of conc. (Tc) = 82.7 min
 Distribution = Type III
 Shape factor = 484

Hydrograph Volume = 3,473 cuft

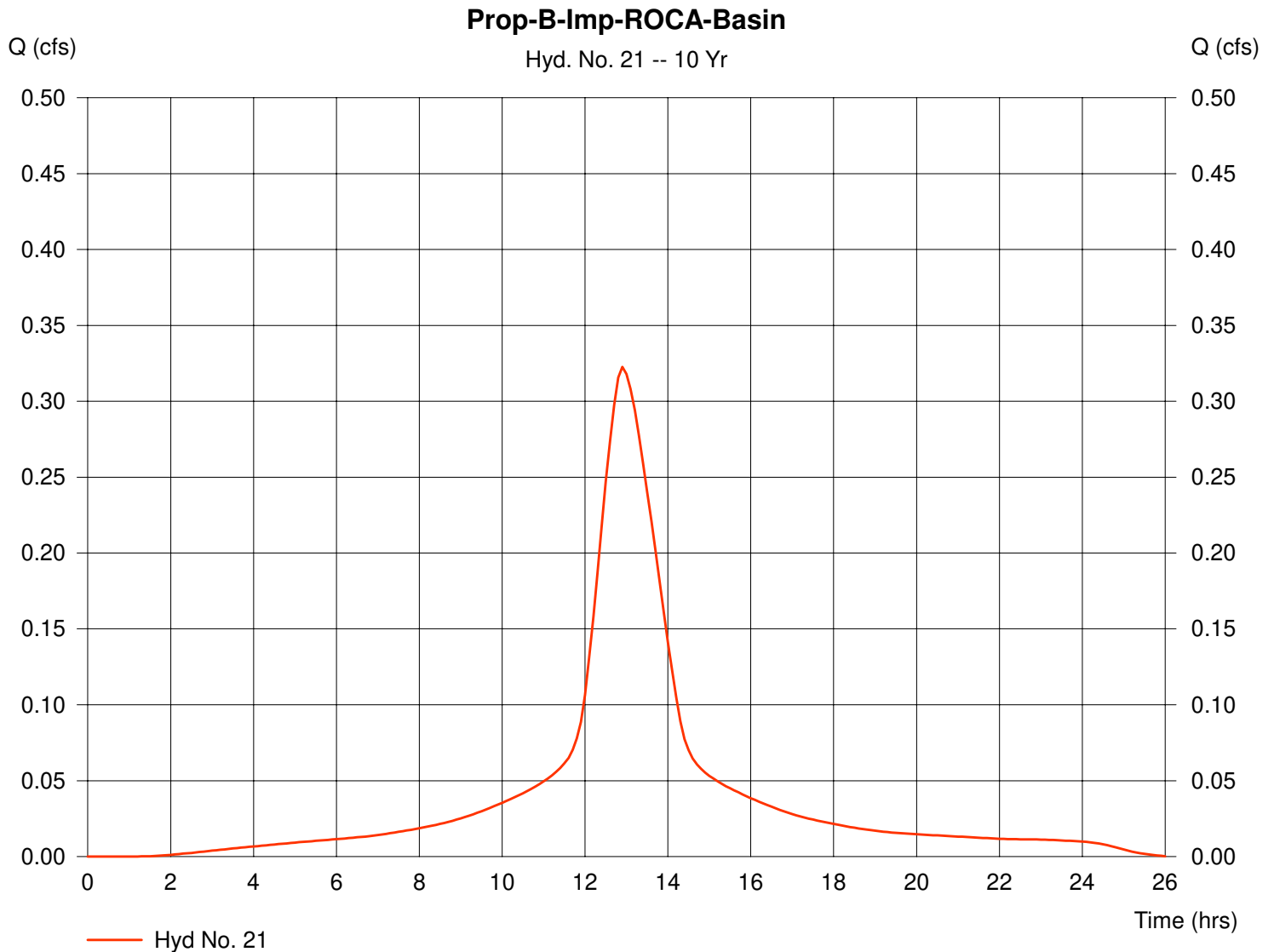

Hydrograph Plot

Hydraflow Hydrographs by Intelisolve

Tuesday, Feb 11 2020, 10:32 AM

Hyd. No. 22

Prop-B-Perv-ROCA-Basin

Hydrograph type = SCS Runoff
 Storm frequency = 10 yrs
 Drainage area = 10.79 ac
 Basin Slope = 0.0 %
 Tc method = USER
 Total precip. = 5.02 in
 Storm duration = 24 hrs

Peak discharge = 0.25 cfs
 Time interval = 6 min
 Curve number = 38
 Hydraulic length = 0 ft
 Time of conc. (Tc) = 82.7 min
 Distribution = Type III
 Shape factor = 484

Hydrograph Volume = 6,682 cuft

Prop-B-Perv-ROCA-Basin

Hyd. No. 22 -- 10 Yr

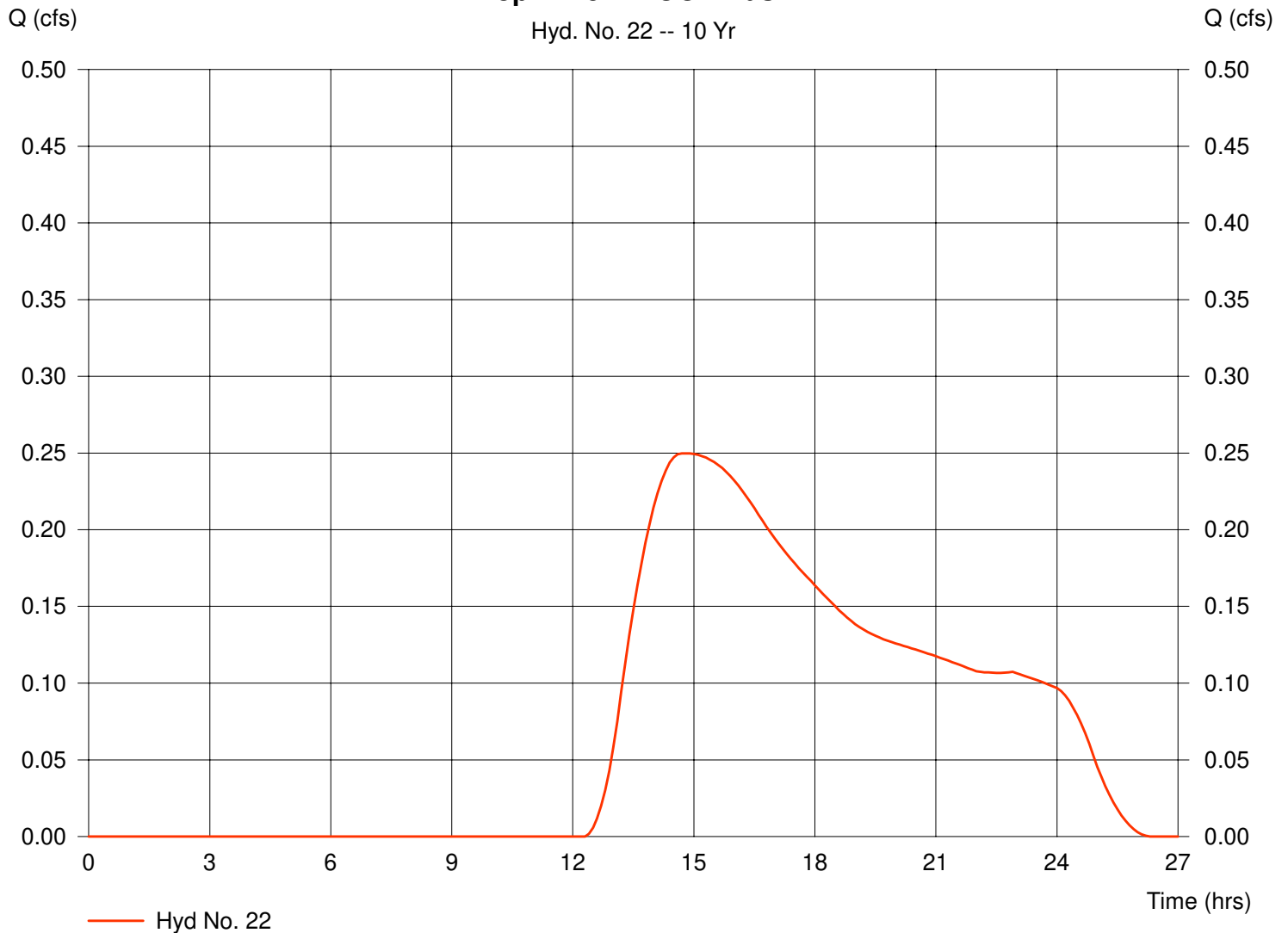

Hydrograph Plot

Hydraflow Hydrographs by Intelisolve

Tuesday, Feb 11 2020, 10:32 AM

Hyd. No. 23

ROCA Basin Inflow

Hydrograph type = Combine
Storm frequency = 10 yrs
Inflow hyds. = 21, 22

Peak discharge = 0.39 cfs
Time interval = 6 min

Hydrograph Volume = 10,155 cuft

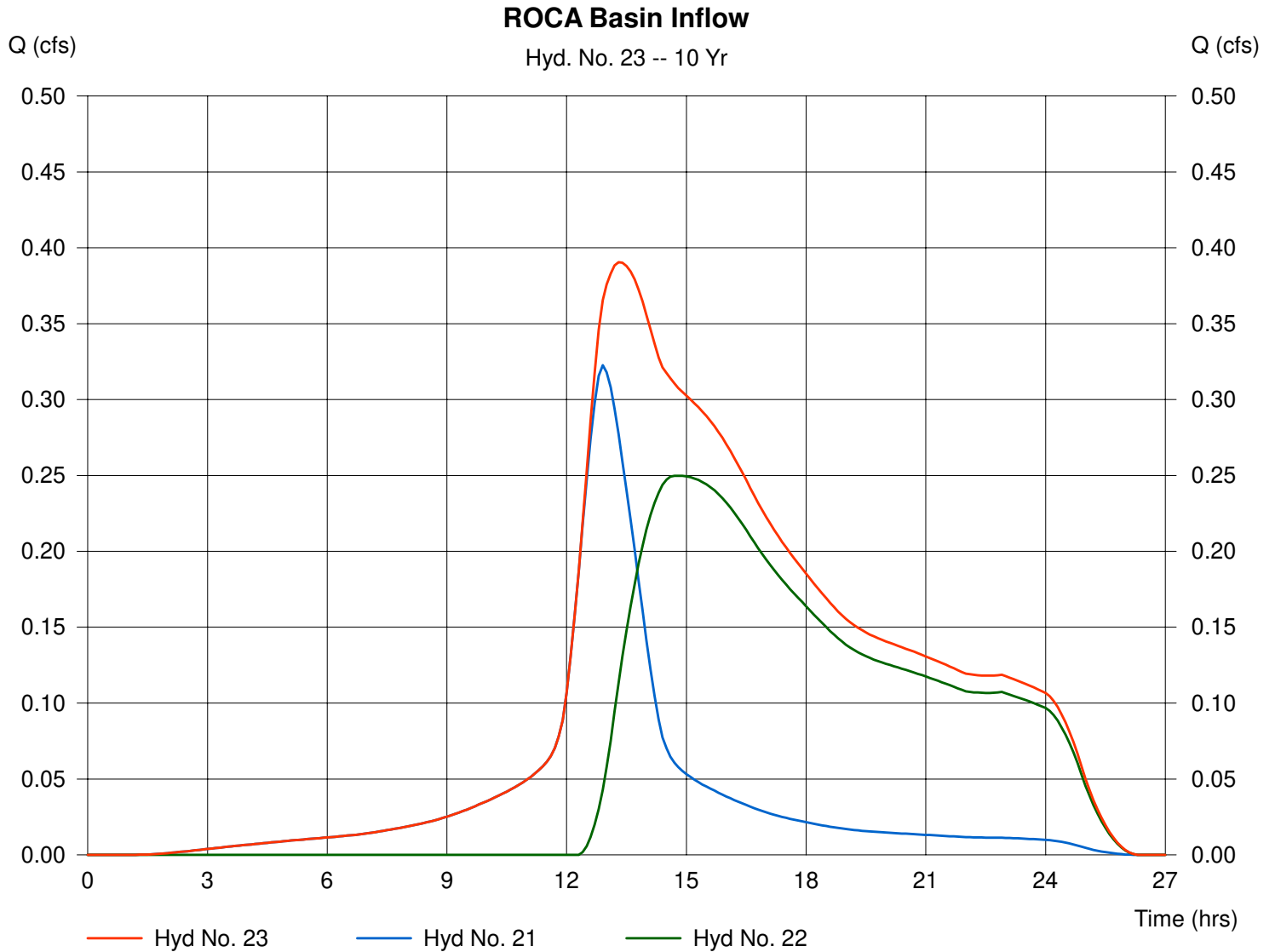

Hydrograph Plot

Hydraflow Hydrographs by Intelisolve

Tuesday, Feb 11 2020, 10:32 AM

Hyd. No. 24

ROCA Basin Routing

Hydrograph type = Reservoir
Storm frequency = 10 yrs
Inflow hyd. No. = 23
Reservoir name = ROCA Basin

Peak discharge = 0.22 cfs
Time interval = 6 min
Max. Elevation = 154.89 ft
Max. Storage = 4,106 cuft

Storage Indication method used.

Hydrograph Volume = 9,028 cuft

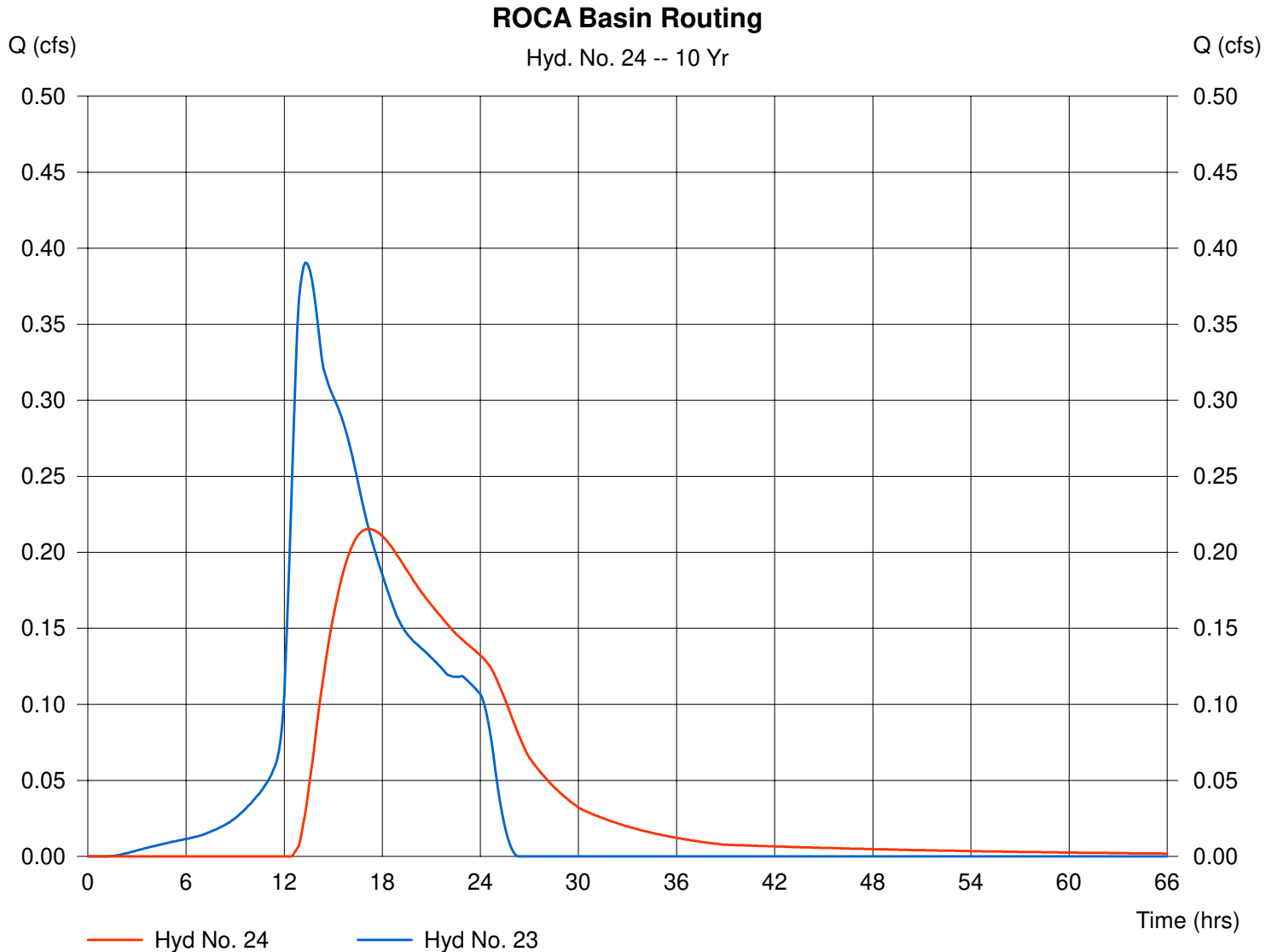

Pond Report

Hydraflow Hydrographs by Intelisolve

Tuesday, Feb 11 2020, 10:32 AM

Pond No. 2 - ROCA Basin

Pond Data

Pond storage is based on known contour areas. Average end area method used.

Stage / Storage Table

Stage (ft)	Elevation (ft)	Contour area (sqft)	Incr. Storage (cuft)	Total storage (cuft)
0.00	154.50	10,126	0	0
0.50	155.00	11,053	5,295	5,295
1.50	156.00	13,036	12,045	17,339
2.00	156.50	14,055	6,773	24,112

Culvert / Orifice Structures

	[A]	[B]	[C]	[D]
Rise (in)	= 18.00	6.00	0.00	0.00
Span (in)	= 18.00	6.00	0.00	0.00
No. Barrels	= 1	1	0	0
Invert El. (ft)	= 154.50	154.60	0.00	0.00
Length (ft)	= 115.00	0.00	0.00	0.00
Slope (%)	= 1.30	0.00	0.00	0.00
N-Value	= .013	.013	.000	.000
Orif. Coeff.	= 0.60	0.60	0.00	0.00
Multi-Stage	= n/a	Yes	No	No

Weir Structures

	[A]	[B]	[C]	[D]
Crest Len (ft)	= 16.00	0.00	0.00	0.00
Crest El. (ft)	= 156.50	0.00	0.00	0.00
Weir Coeff.	= 3.33	3.33	0.00	0.00
Weir Type	= Riser	---	---	---
Multi-Stage	= Yes	No	No	No

Exfiltration = 0.000 in/hr (Contour) Tailwater Elev. = 0.00 ft

Note: Culvert/Orifice outflows have been analyzed under inlet and outlet control.

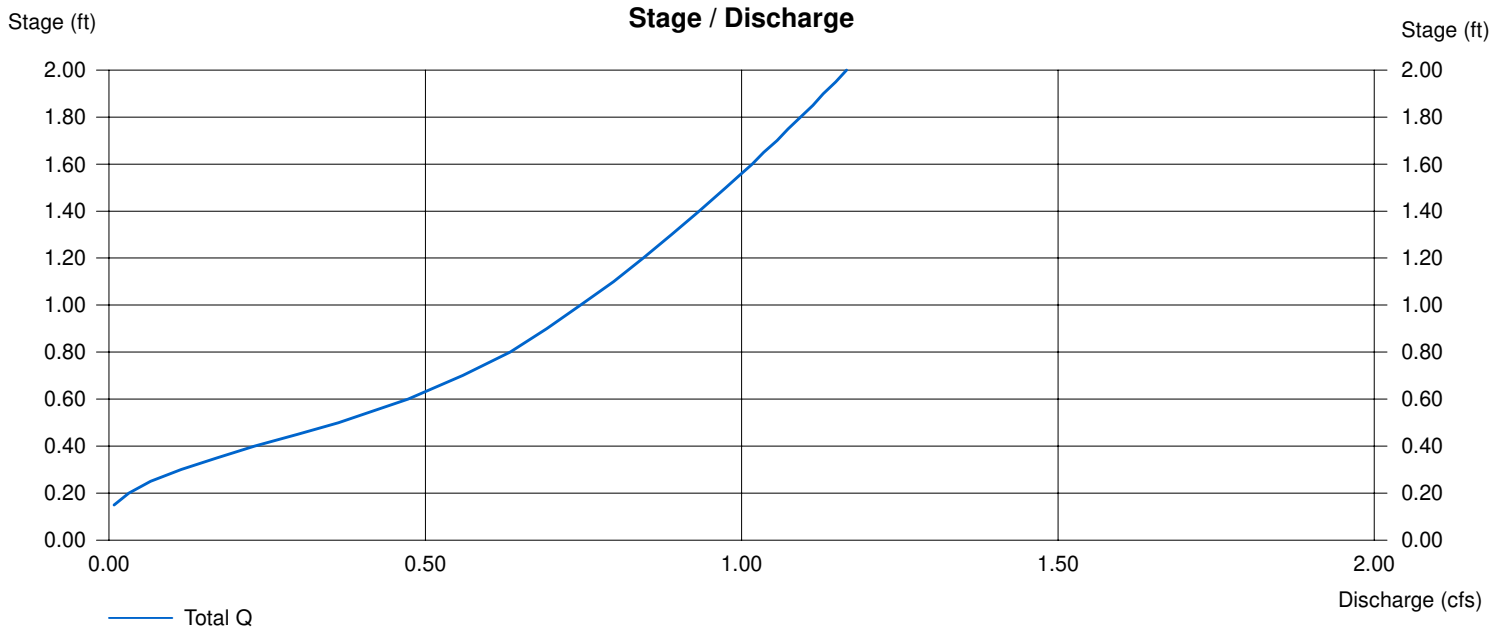

Hydrograph Plot

Hydraflow Hydrographs by Intelisolve

Tuesday, Feb 11 2020, 10:32 AM

Hyd. No. 25

Prop-B

Hydrograph type = Combine
Storm frequency = 10 yrs
Inflow hyds. = 14, 15

Peak discharge = 0.19 cfs
Time interval = 6 min

Hydrograph Volume = 4,057 cuft

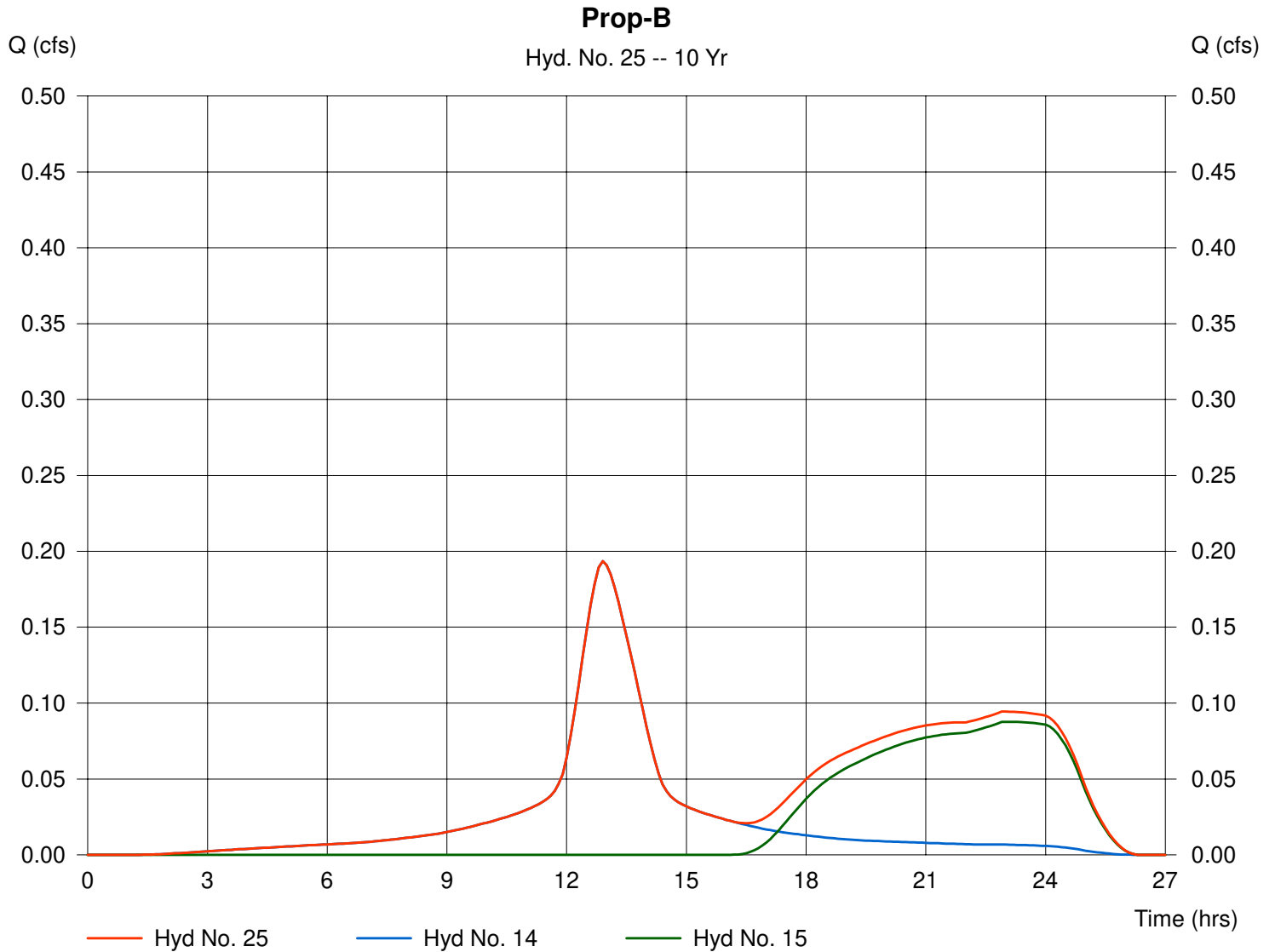

Hydrograph Plot

Hydraflow Hydrographs by Intelisolve

Tuesday, Feb 11 2020, 10:32 AM

Hyd. No. 26

Prop-B

Hydrograph type = Combine
Storm frequency = 10 yrs
Inflow hyds. = 20, 24, 25

Peak discharge = 0.42 cfs
Time interval = 6 min

Hydrograph Volume = 29,009 cuft

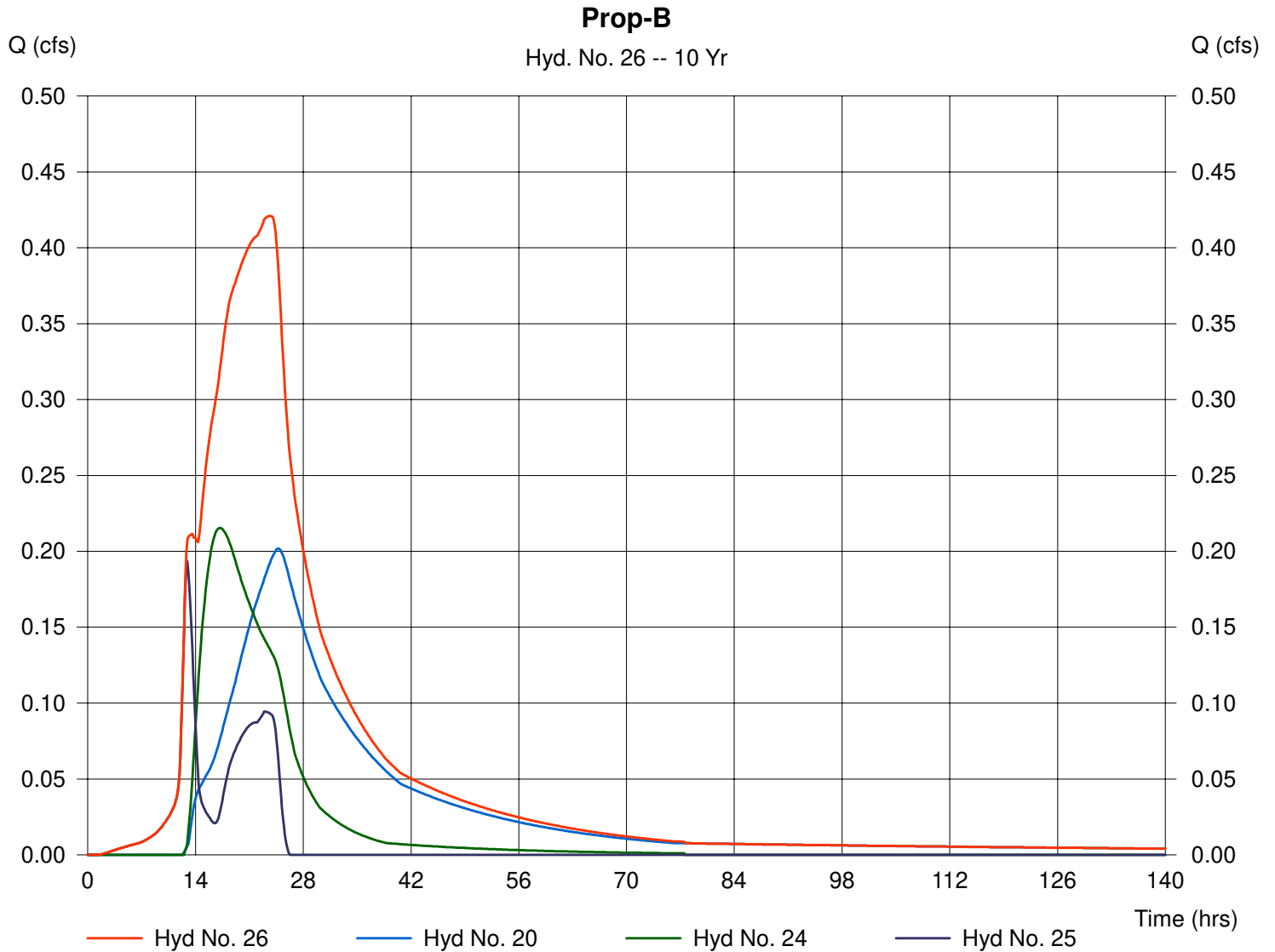

Hydrograph Plot

Hydraflow Hydrographs by Intelisolve

Tuesday, Feb 11 2020, 10:32 AM

Hyd. No. 29

Exist-C-Imp

Hydrograph type = SCS Runoff
Storm frequency = 10 yrs
Drainage area = 1.66 ac
Basin Slope = 0.0 %
Tc method = USER
Total precip. = 5.02 in
Storm duration = 24 hrs

Peak discharge = 2.87 cfs
Time interval = 6 min
Curve number = 98
Hydraulic length = 0 ft
Time of conc. (Tc) = 76.33 min
Distribution = Type III
Shape factor = 484

Hydrograph Volume = 28,372 cuft

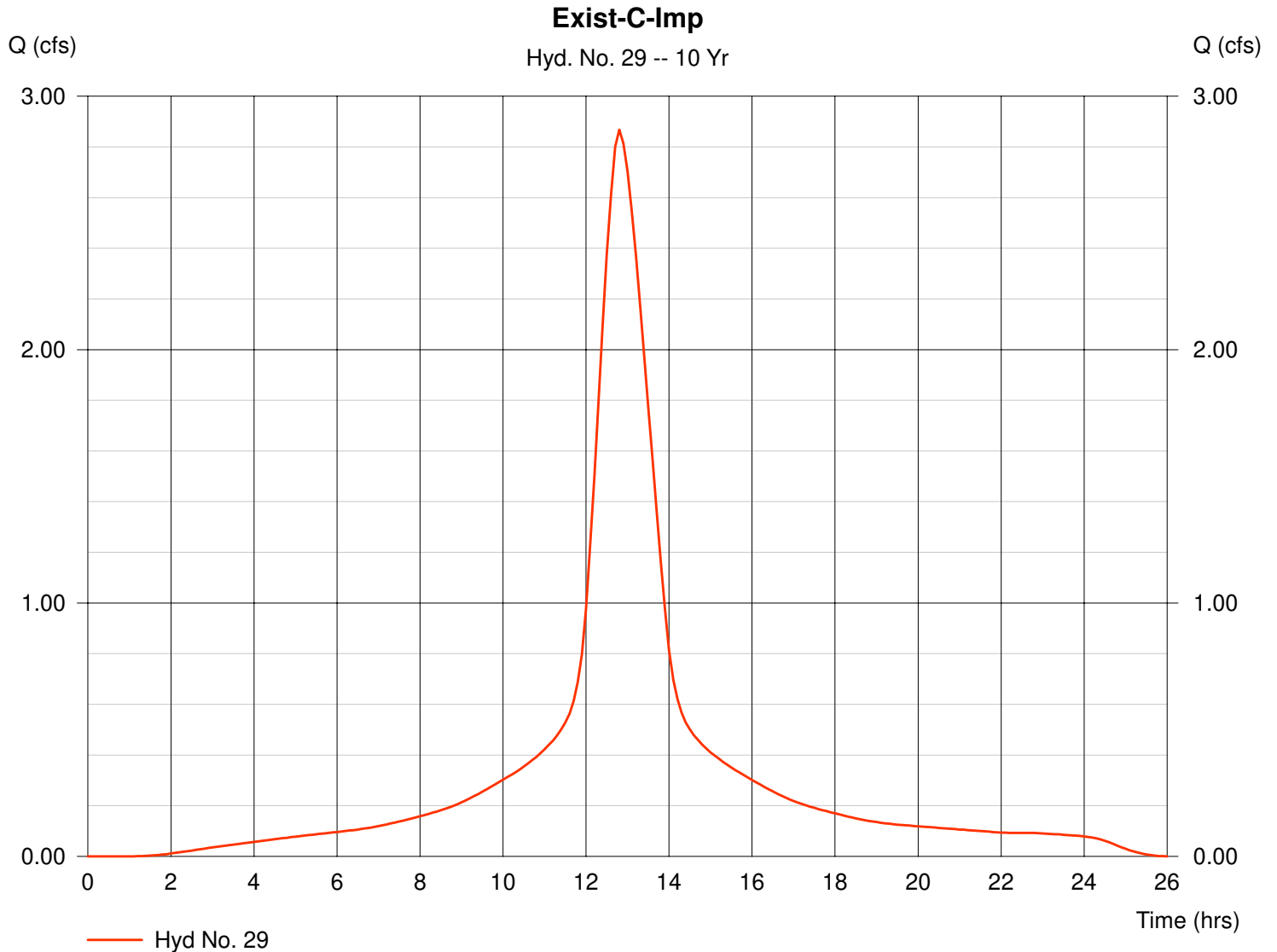

Hydrograph Plot

Hydraflow Hydrographs by Intelisolve

Tuesday, Feb 11 2020, 10:32 AM

Hyd. No. 30

Exist-C-Perv

Hydrograph type = SCS Runoff
Storm frequency = 10 yrs
Drainage area = 130.63 ac
Basin Slope = 0.0 %
Tc method = USER
Total precip. = 5.02 in
Storm duration = 24 hrs

Peak discharge = 4.79 cfs
Time interval = 6 min
Curve number = 40
Hydraulic length = 0 ft
Time of conc. (Tc) = 76.33 min
Distribution = Type III
Shape factor = 484

Hydrograph Volume = 111,760 cuft

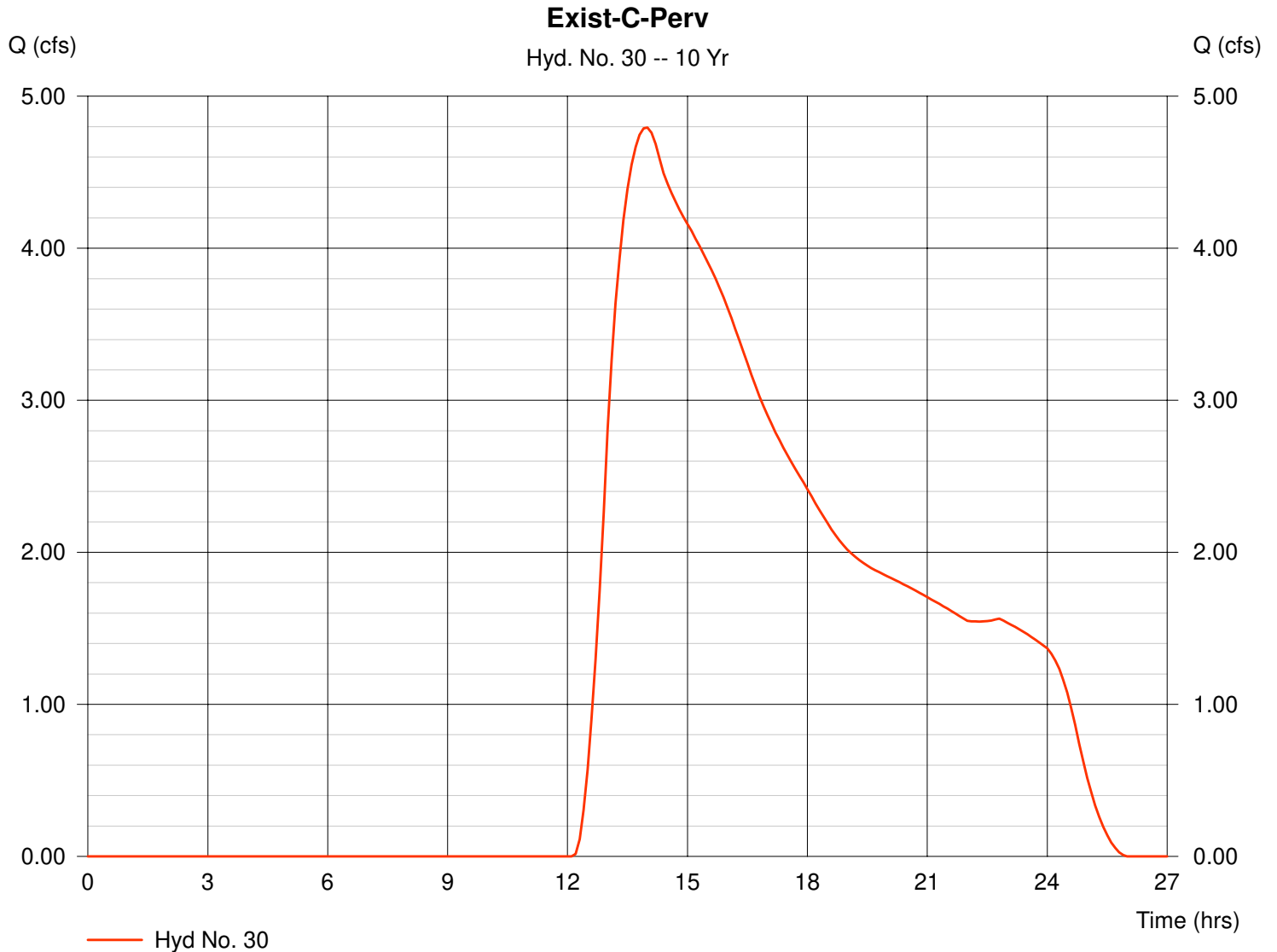

Hydrograph Plot

Hydraflow Hydrographs by Intelisolve

Tuesday, Feb 11 2020, 10:32 AM

Hyd. No. 31

Exist-C

Hydrograph type = Combine
Storm frequency = 10 yrs
Inflow hyds. = 29, 30

Peak discharge = 6.16 cfs
Time interval = 6 min

Hydrograph Volume = 140,131 cuft

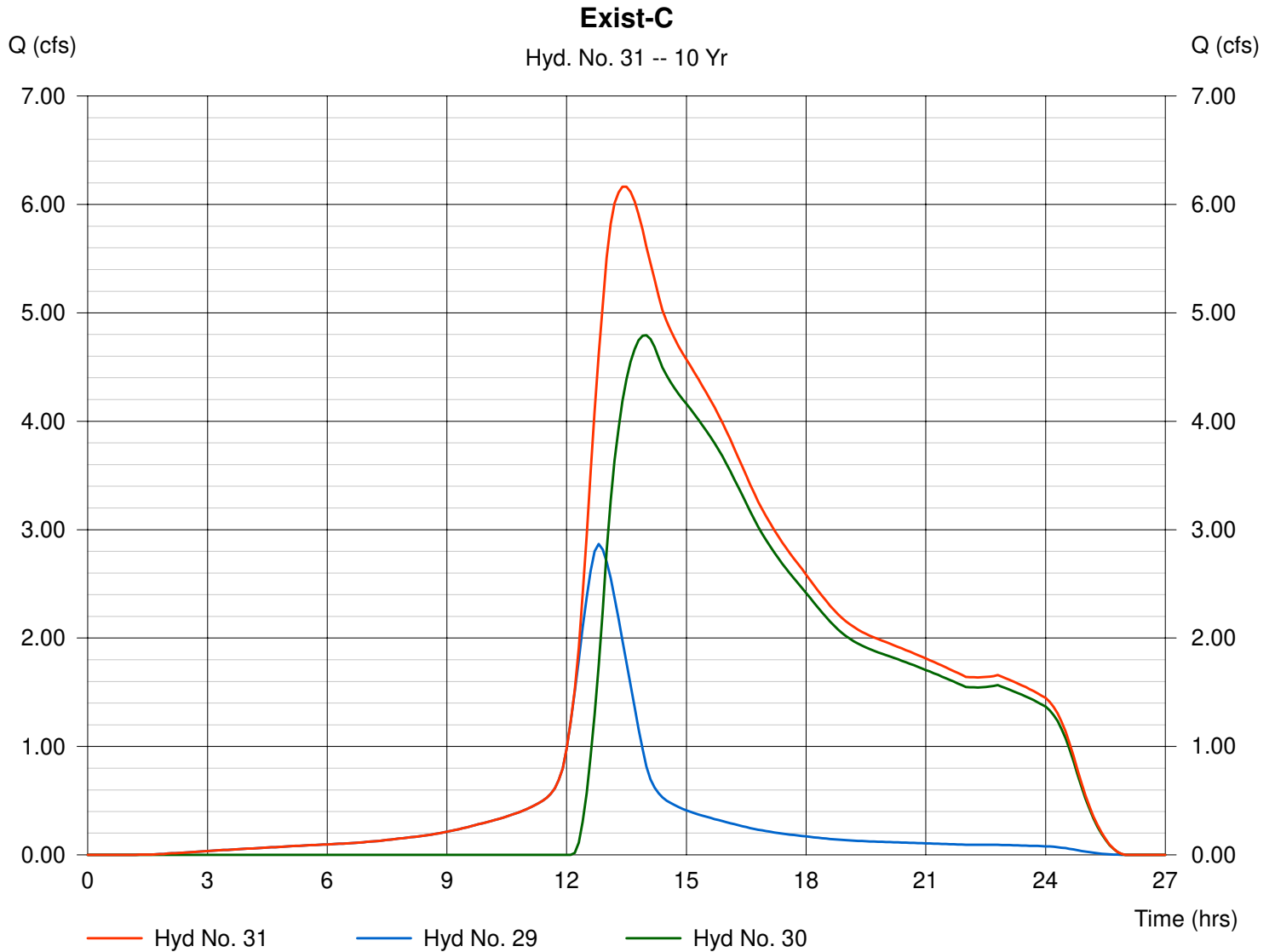

Hydrograph Plot

Hydraflow Hydrographs by Intelisolve

Tuesday, Feb 11 2020, 10:32 AM

Hyd. No. 33

Prop-C-Imp

Hydrograph type = SCS Runoff
Storm frequency = 10 yrs
Drainage area = 1.42 ac
Basin Slope = 0.0 %
Tc method = USER
Total precip. = 5.02 in
Storm duration = 24 hrs

Peak discharge = 2.45 cfs
Time interval = 6 min
Curve number = 98
Hydraulic length = 0 ft
Time of conc. (Tc) = 75.49 min
Distribution = Type III
Shape factor = 484

Hydrograph Volume = 24,270 cuft

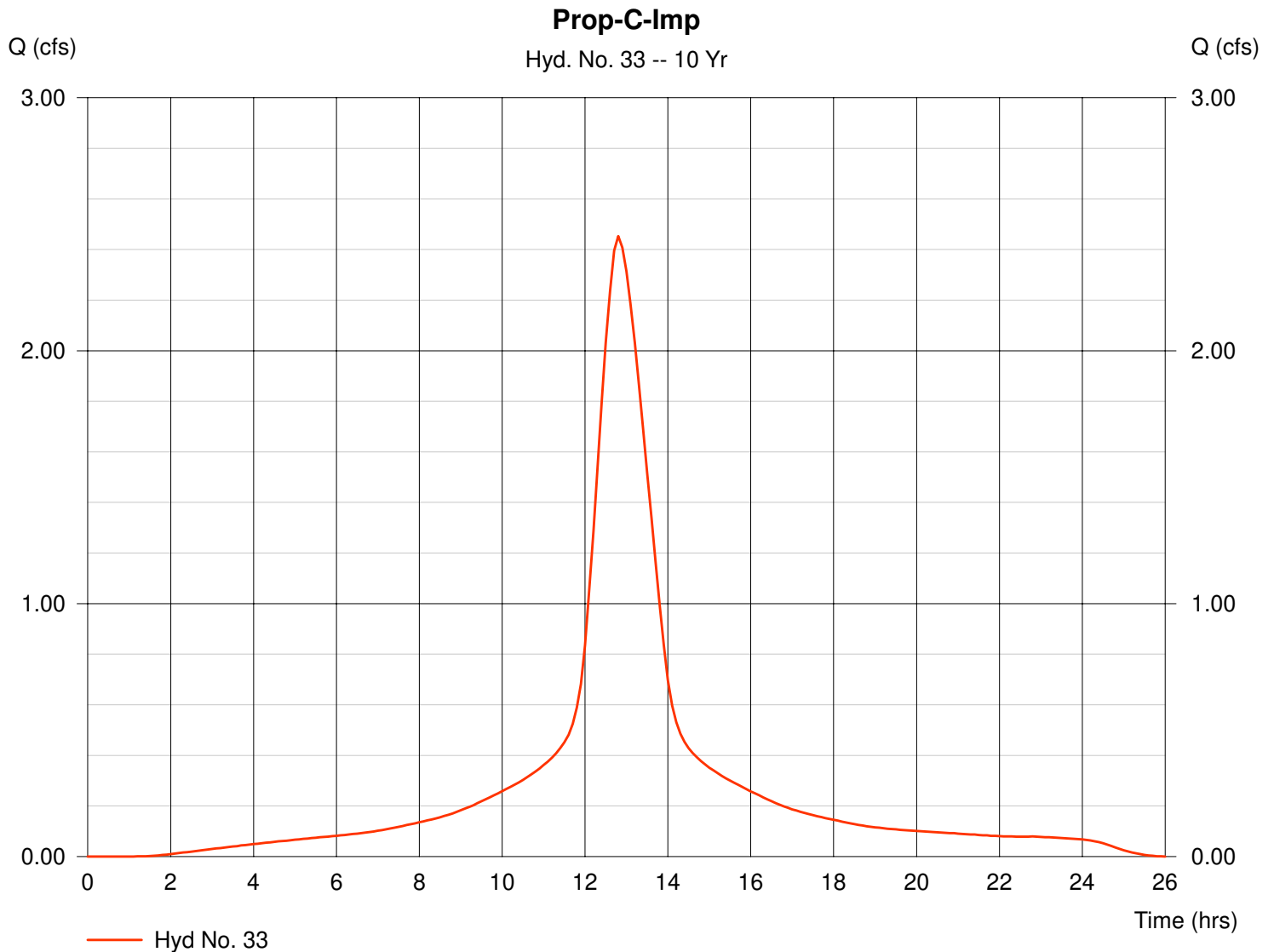

Hydrograph Plot

Hydraflow Hydrographs by Intelisolve

Tuesday, Feb 11 2020, 10:32 AM

Hyd. No. 34

Prop-C-Perv

Hydrograph type = SCS Runoff
Storm frequency = 10 yrs
Drainage area = 133.04 ac
Basin Slope = 0.0 %
Tc method = USER
Total precip. = 5.02 in
Storm duration = 24 hrs

Peak discharge = 4.88 cfs
Time interval = 6 min
Curve number = 40
Hydraulic length = 0 ft
Time of conc. (Tc) = 75.49 min
Distribution = Type III
Shape factor = 484

Hydrograph Volume = 113,822 cuft

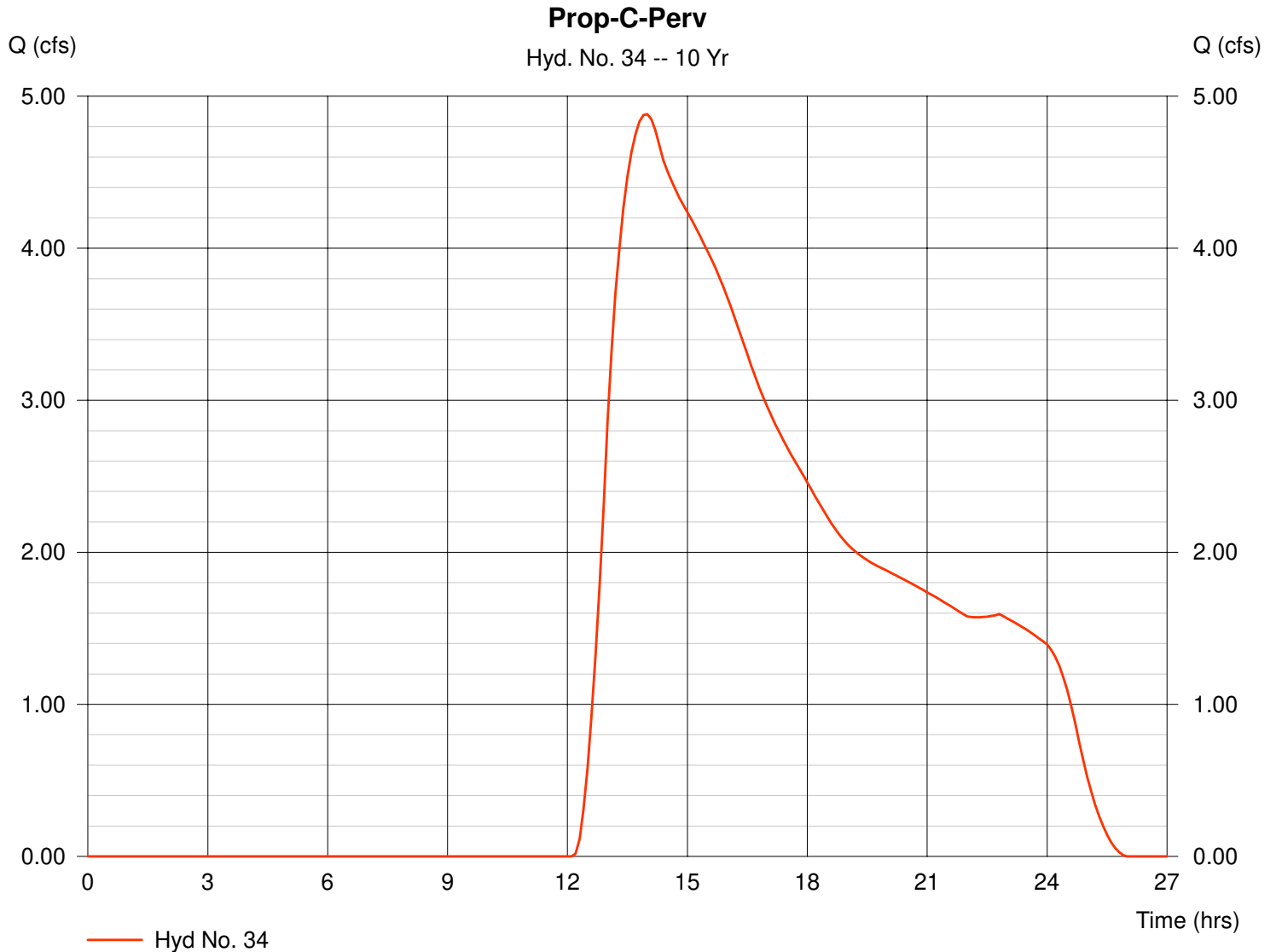

Hydrograph Plot

Hydraflow Hydrographs by Intelisolve

Tuesday, Feb 11 2020, 10:32 AM

Hyd. No. 35

Prop-C

Hydrograph type = Combine
Storm frequency = 10 yrs
Inflow hyds. = 33, 34

Peak discharge = 5.99 cfs
Time interval = 6 min

Hydrograph Volume = 138,091 cuft

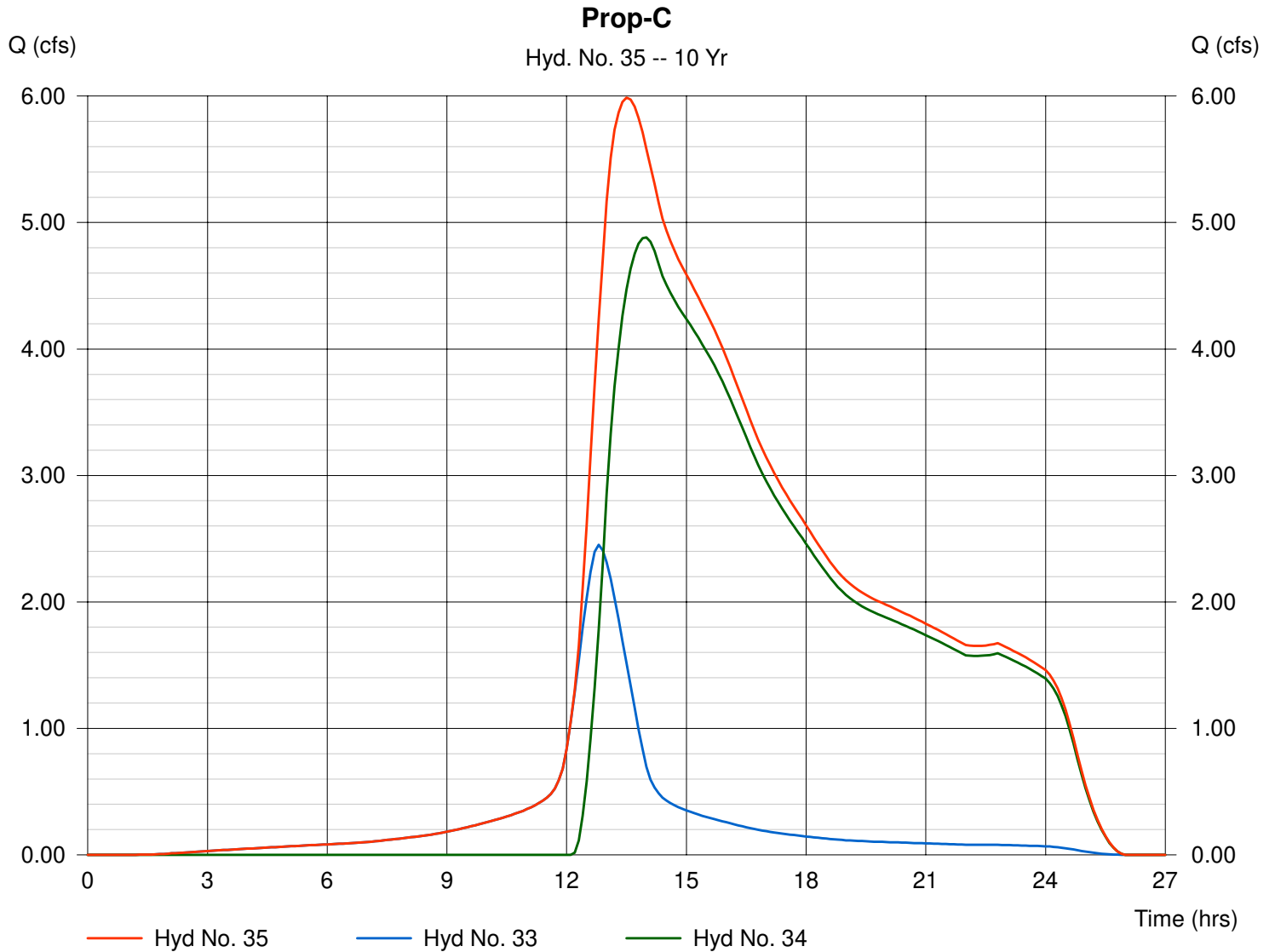

Hydrograph Summary Report

Hyd. No.	Hydrograph type (origin)	Peak flow (cfs)	Time interval (min)	Time to peak (min)	Volume (cuft)	Inflow hyd(s)	Maximum elevation (ft)	Maximum storage (cuft)	Hydrograph description
1	SCS Runoff	4.79	6	780	55,907	---	-----	-----	Exist-A-Imp
2	SCS Runoff	9.92	6	834	202,220	---	-----	-----	Exist-A-Perv
3	Combine	13.38	6	810	258,128	1, 2	-----	-----	Exist-A
5	SCS Runoff	4.62	6	774	49,988	---	-----	-----	Prop-A-Imp
6	SCS Runoff	11.39	6	816	208,054	---	-----	-----	Prop-A-Perv
7	Combine	14.96	6	798	258,042	5, 6	-----	-----	Prop-A
10	SCS Runoff	4.52	6	774	48,942	---	-----	-----	Exist-B-Imp
11	SCS Runoff	1.07	6	1002	32,530	---	-----	-----	Exist-B-Perv
12	Combine	4.52	6	774	81,472	10, 11	-----	-----	Exist-B
14	SCS Runoff	0.23	6	774	2,510	---	-----	-----	Prop-B-Imp
15	SCS Runoff	0.49	6	966	14,042	---	-----	-----	Prop-B-Perv
17	SCS Runoff	1.21	6	774	13,093	---	-----	-----	Prop-B-Imp-FAN-Basin
18	SCS Runoff	1.45	6	948	40,500	---	-----	-----	Prop-B-Perv-FAN-Basin
19	Combine	1.61	6	936	53,593	17, 18	-----	-----	FAN Basin Inflow
20	Reservoir	0.68	6	1458	31,344	19	155.12	32,583	FAN Basin 1 Routing
21	SCS Runoff	0.39	6	774	4,183	---	-----	-----	Prop-B-Imp-ROCA-Basin
22	SCS Runoff	0.73	6	834	15,261	---	-----	-----	Prop-B-Perv-ROCA-Basin
23	Combine	0.99	6	810	19,444	21, 22	-----	-----	ROCA Basin Inflow
24	Reservoir	0.49	6	978	18,317	23	155.12	6,745	ROCA Basin Routing
25	Combine	0.51	6	966	16,551	14, 15,	-----	-----	Prop-B
26	Combine	1.48	6	1038	66,212	20, 24, 25	-----	-----	Prop-B
29	SCS Runoff	3.43	6	768	34,177	---	-----	-----	Exist-C-Imp
30	SCS Runoff	13.61	6	804	233,389	---	-----	-----	Exist-C-Perv
31	Combine	16.21	6	792	267,566	29, 30	-----	-----	Exist-C

Hydrograph Summary Report

Hyd. No.	Hydrograph type (origin)	Peak flow (cfs)	Time interval (min)	Time to peak (min)	Volume (cuft)	Inflow hyd(s)	Maximum elevation (ft)	Maximum storage (cuft)	Hydrograph description
33	SCS Runoff	2.94	6	768	29,236	---	-----	-----	Prop-C-Imp
34	SCS Runoff	13.86	6	804	237,695	---	-----	-----	Prop-C-Perv
35	Combine	16.04	6	792	266,931	33, 34	-----	-----	Prop-C

Hydrograph Plot

Hydraflow Hydrographs by Intelisolve

Tuesday, Feb 11 2020, 10:32 AM

Hyd. No. 1

Exist-A-Imp

Hydrograph type = SCS Runoff
Storm frequency = 25 yrs
Drainage area = 2.64 ac
Basin Slope = 0.0 %
Tc method = USER
Total precip. = 6.00 in
Storm duration = 24 hrs

Peak discharge = 4.79 cfs
Time interval = 6 min
Curve number = 98
Hydraulic length = 0 ft
Time of conc. (Tc) = 91.29 min
Distribution = Type III
Shape factor = 484

Hydrograph Volume = 55,907 cuft

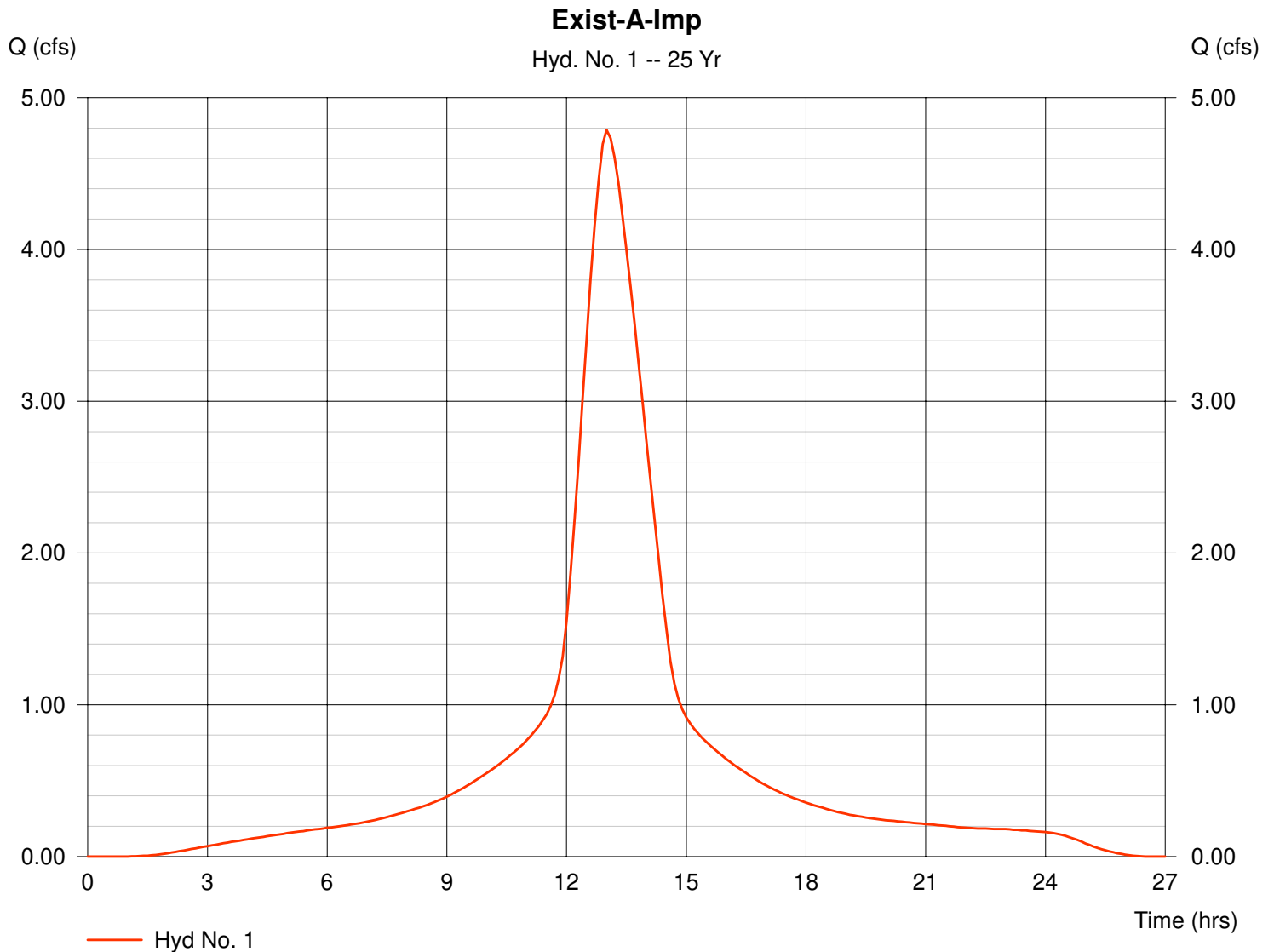

Hydrograph Plot

Hydraflow Hydrographs by Intelisolve

Tuesday, Feb 11 2020, 10:32 AM

Hyd. No. 2

Exist-A-Perv

Hydrograph type = SCS Runoff
Storm frequency = 25 yrs
Drainage area = 123.80 ac
Basin Slope = 0.0 %
Tc method = USER
Total precip. = 6.00 in
Storm duration = 24 hrs

Peak discharge = 9.92 cfs
Time interval = 6 min
Curve number = 39
Hydraulic length = 0 ft
Time of conc. (Tc) = 91.29 min
Distribution = Type III
Shape factor = 484

Hydrograph Volume = 202,220 cuft

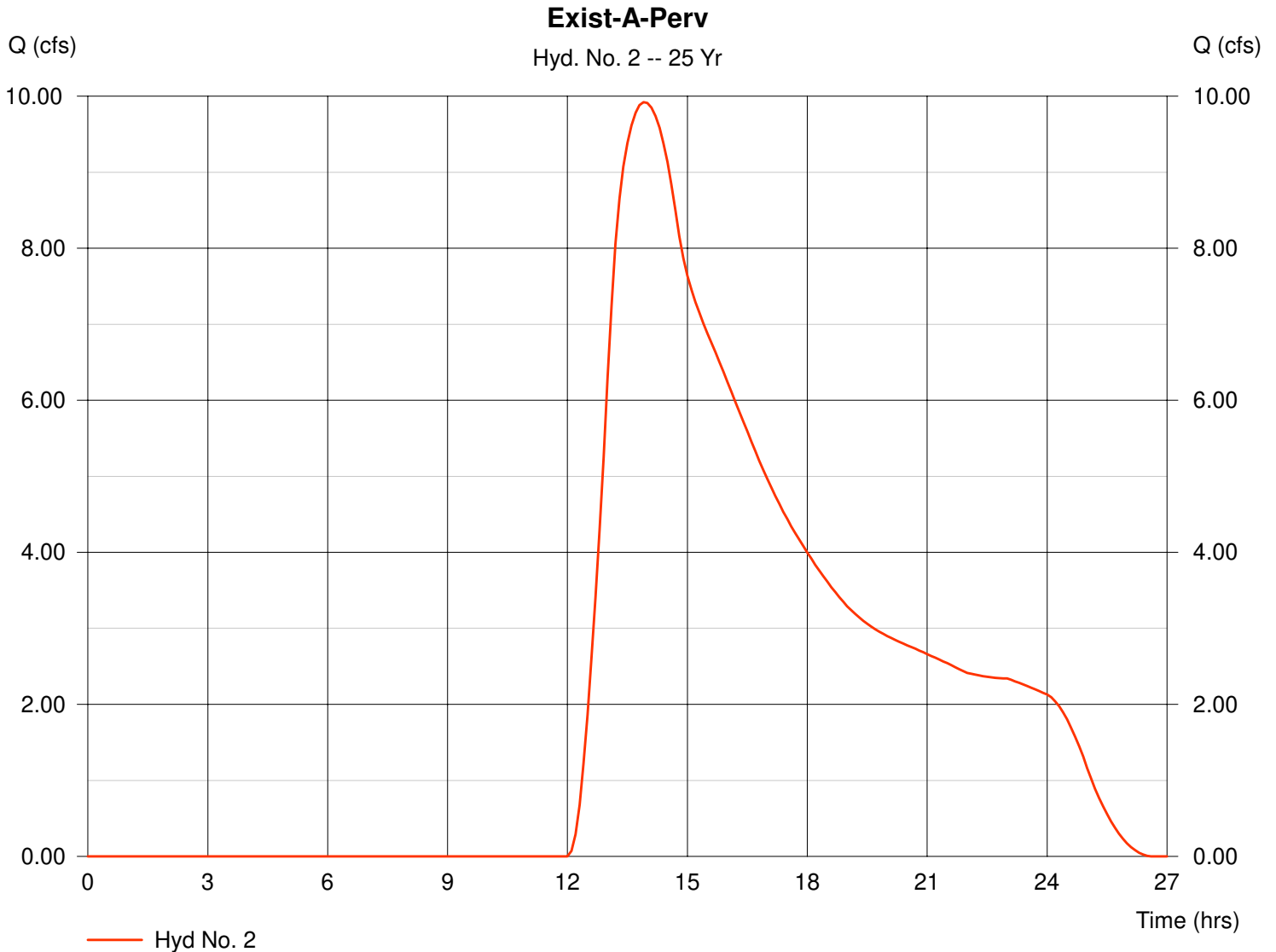

Hydrograph Plot

Hydraflow Hydrographs by Intelisolve

Tuesday, Feb 11 2020, 10:32 AM

Hyd. No. 3

Exist-A

Hydrograph type = Combine
 Storm frequency = 25 yrs
 Inflow hyds. = 1, 2

Peak discharge = 13.38 cfs
 Time interval = 6 min

Hydrograph Volume = 258,128 cuft

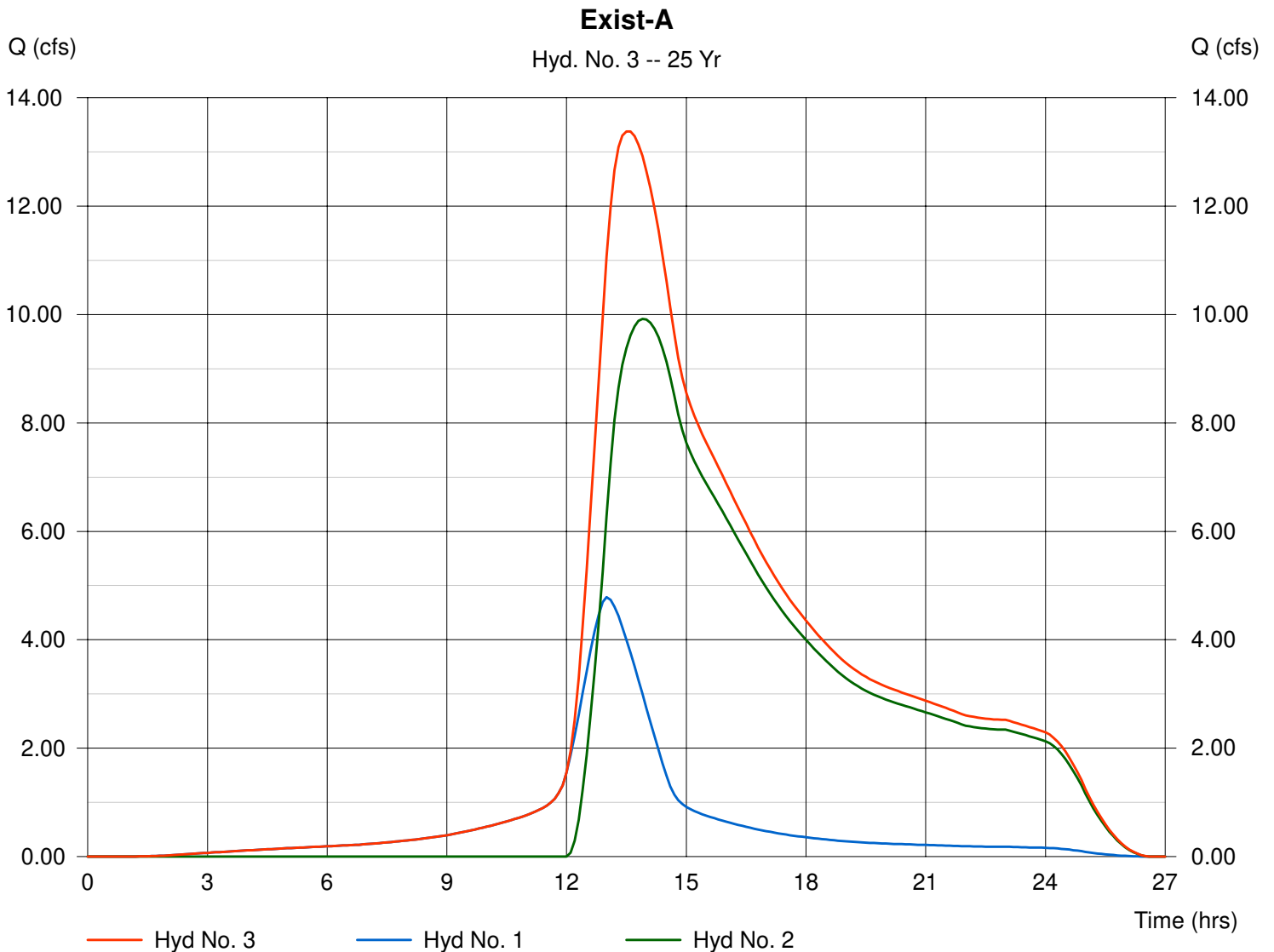

Hydrograph Plot

Hydraflow Hydrographs by Intelisolve

Tuesday, Feb 11 2020, 10:32 AM

Hyd. No. 5

Prop-A-Imp

Hydrograph type = SCS Runoff
Storm frequency = 25 yrs
Drainage area = 2.39 ac
Basin Slope = 0.0 %
Tc method = USER
Total precip. = 6.00 in
Storm duration = 24 hrs

Peak discharge = 4.62 cfs
Time interval = 6 min
Curve number = 98
Hydraulic length = 0 ft
Time of conc. (Tc) = 90.72 min
Distribution = Type III
Shape factor = 484

Hydrograph Volume = 49,988 cuft

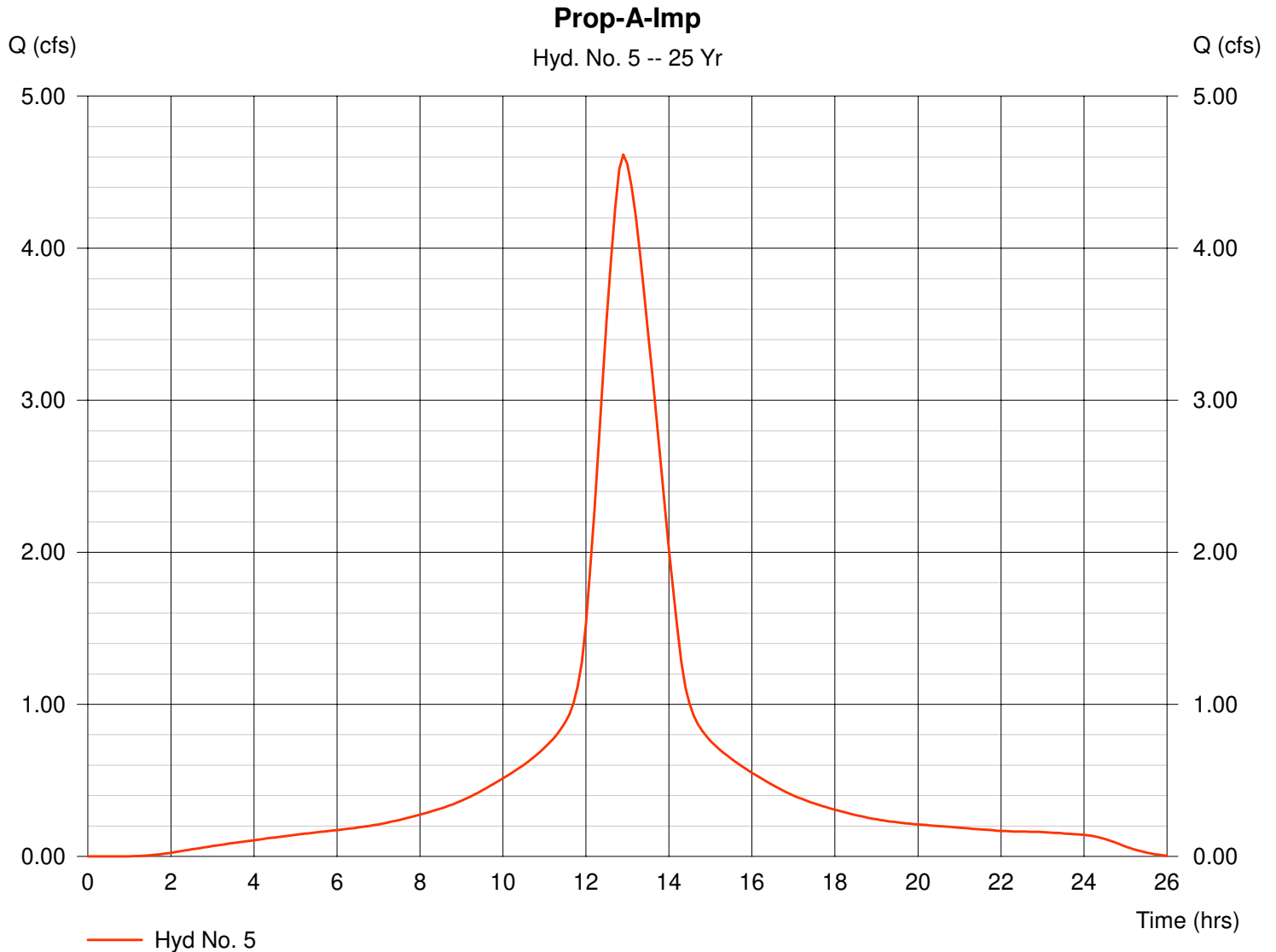

Hydrograph Plot

Hydraflow Hydrographs by Intelisolve

Tuesday, Feb 11 2020, 10:32 AM

Hyd. No. 6

Prop-A-Perv

Hydrograph type = SCS Runoff
Storm frequency = 25 yrs
Drainage area = 114.63 ac
Basin Slope = 0.0 %
Tc method = USER
Total precip. = 6.00 in
Storm duration = 24 hrs

Peak discharge = 11.39 cfs
Time interval = 6 min
Curve number = 40
Hydraulic length = 0 ft
Time of conc. (Tc) = 90.7 min
Distribution = Type III
Shape factor = 484

Hydrograph Volume = 208,054 cuft

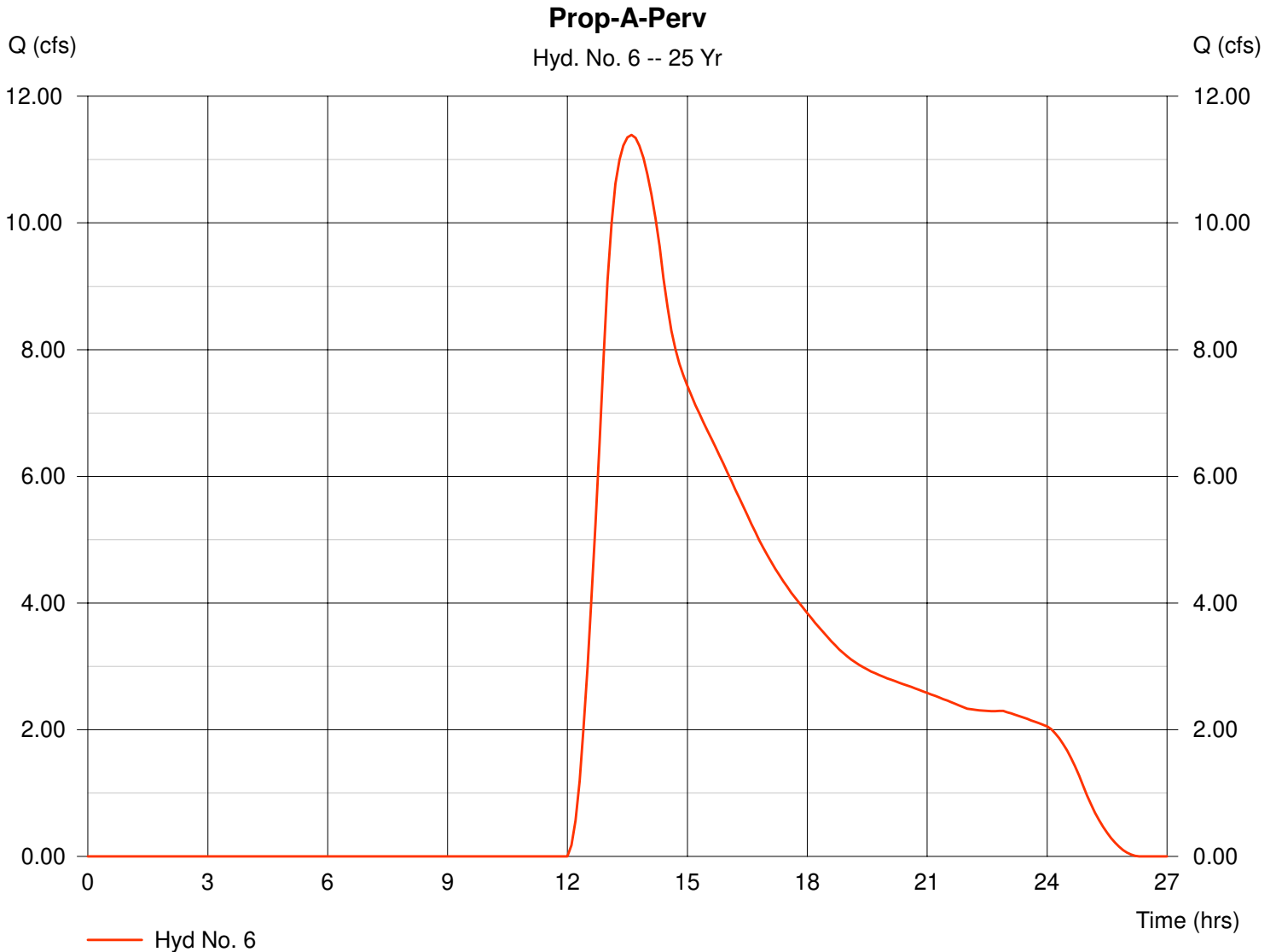

Hydrograph Plot

Hydraflow Hydrographs by Intelisolve

Tuesday, Feb 11 2020, 10:32 AM

Hyd. No. 7

Prop-A

Hydrograph type = Combine
Storm frequency = 25 yrs
Inflow hyds. = 5, 6

Peak discharge = 14.96 cfs
Time interval = 6 min

Hydrograph Volume = 258,042 cuft

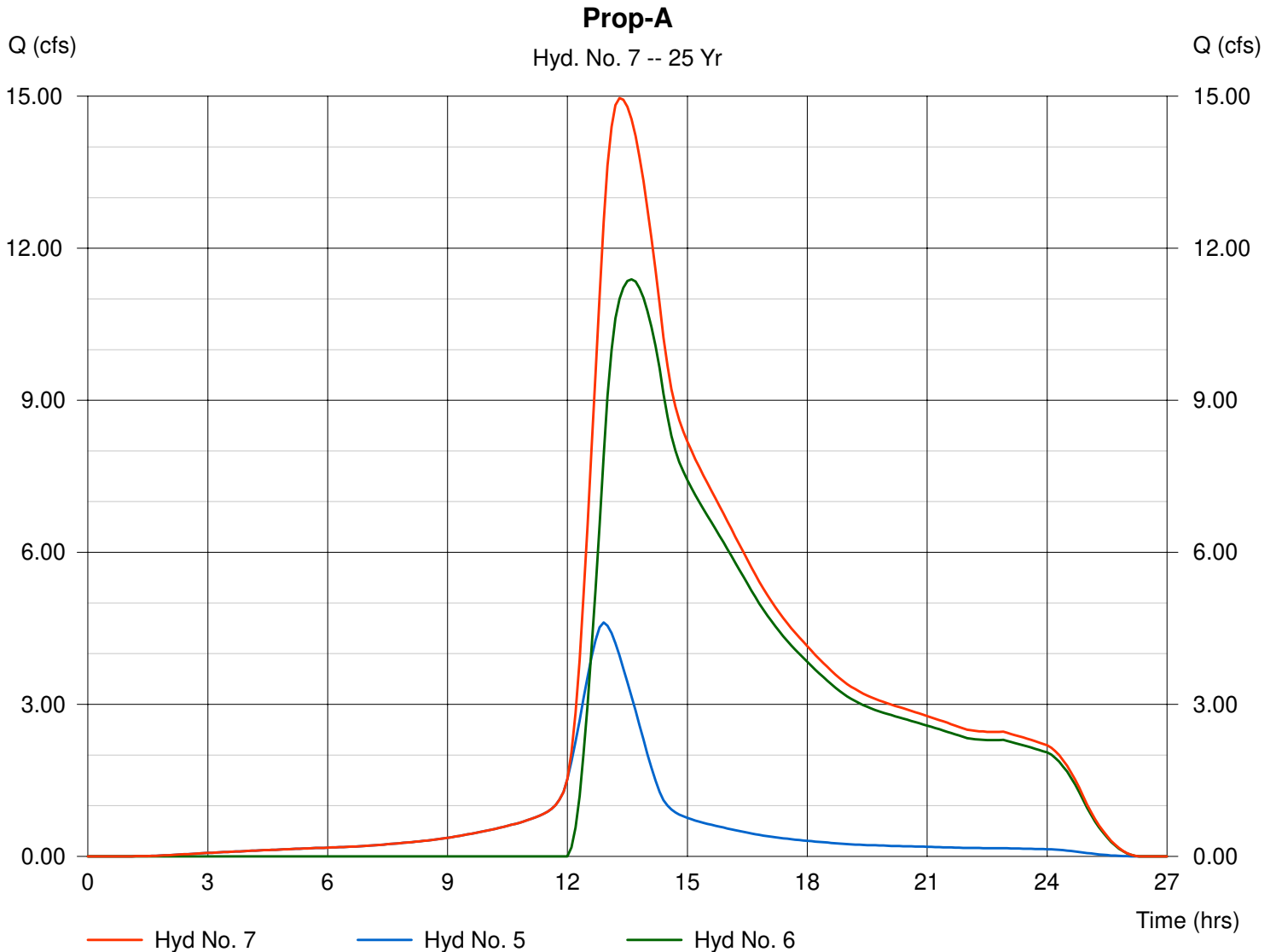

Hydrograph Plot

Hydraflow Hydrographs by Intelisolve

Tuesday, Feb 11 2020, 10:32 AM

Hyd. No. 10

Exist-B-Imp

Hydrograph type = SCS Runoff
Storm frequency = 25 yrs
Drainage area = 2.34 ac
Basin Slope = 0.0 %
Tc method = USER
Total precip. = 6.00 in
Storm duration = 24 hrs

Peak discharge = 4.52 cfs
Time interval = 6 min
Curve number = 98
Hydraulic length = 0 ft
Time of conc. (Tc) = 87.72 min
Distribution = Type III
Shape factor = 484

Hydrograph Volume = 48,942 cuft

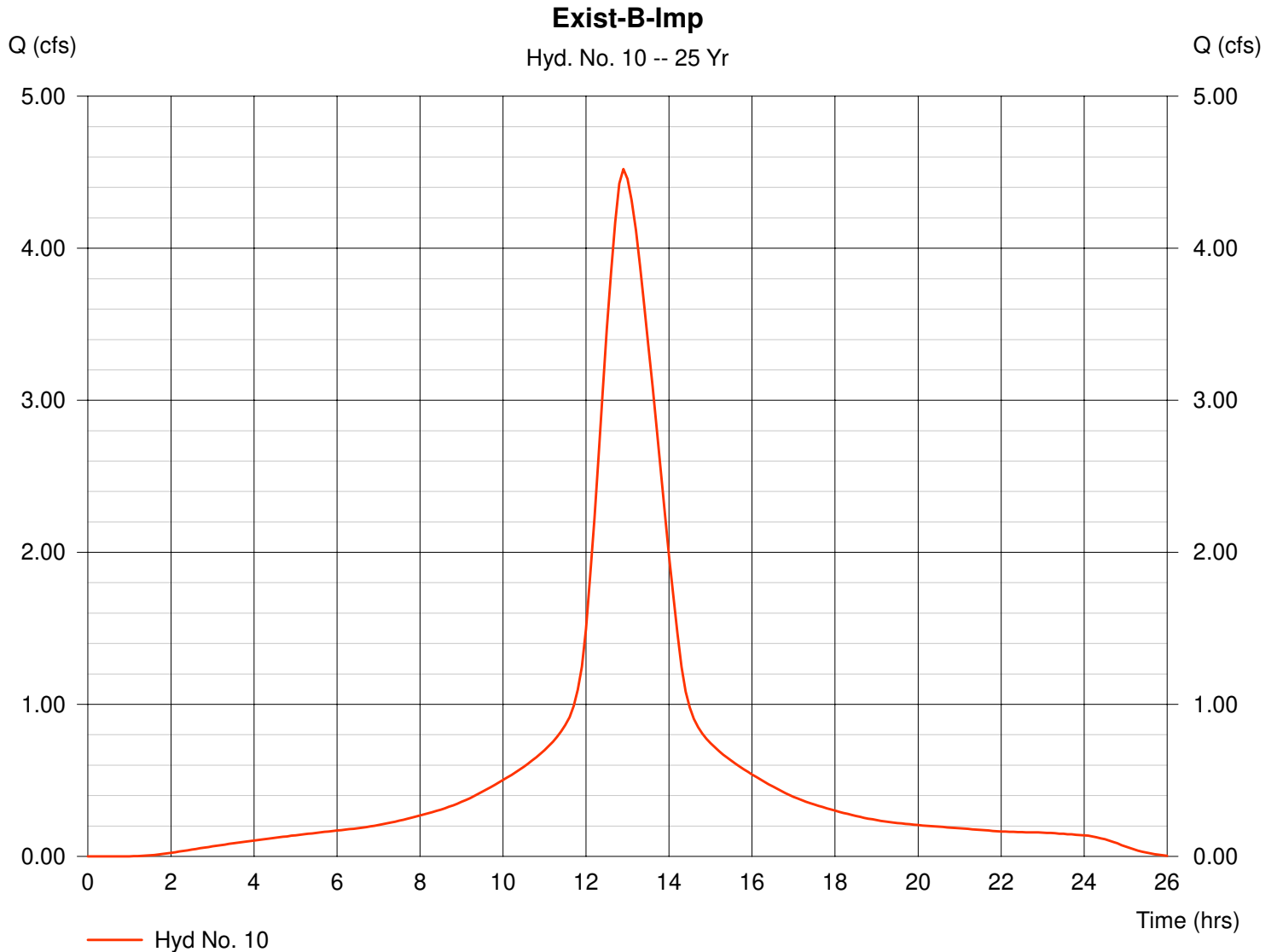

Hydrograph Plot

Hydraflow Hydrographs by Intelisolve

Tuesday, Feb 11 2020, 10:32 AM

Hyd. No. 11

Exist-B-Perv

Hydrograph type = SCS Runoff
Storm frequency = 25 yrs
Drainage area = 124.34 ac
Basin Slope = 0.0 %
Tc method = USER
Total precip. = 6.00 in
Storm duration = 24 hrs

Peak discharge = 1.07 cfs
Time interval = 6 min
Curve number = 30
Hydraulic length = 0 ft
Time of conc. (Tc) = 87.7 min
Distribution = Type III
Shape factor = 484

Hydrograph Volume = 32,530 cuft

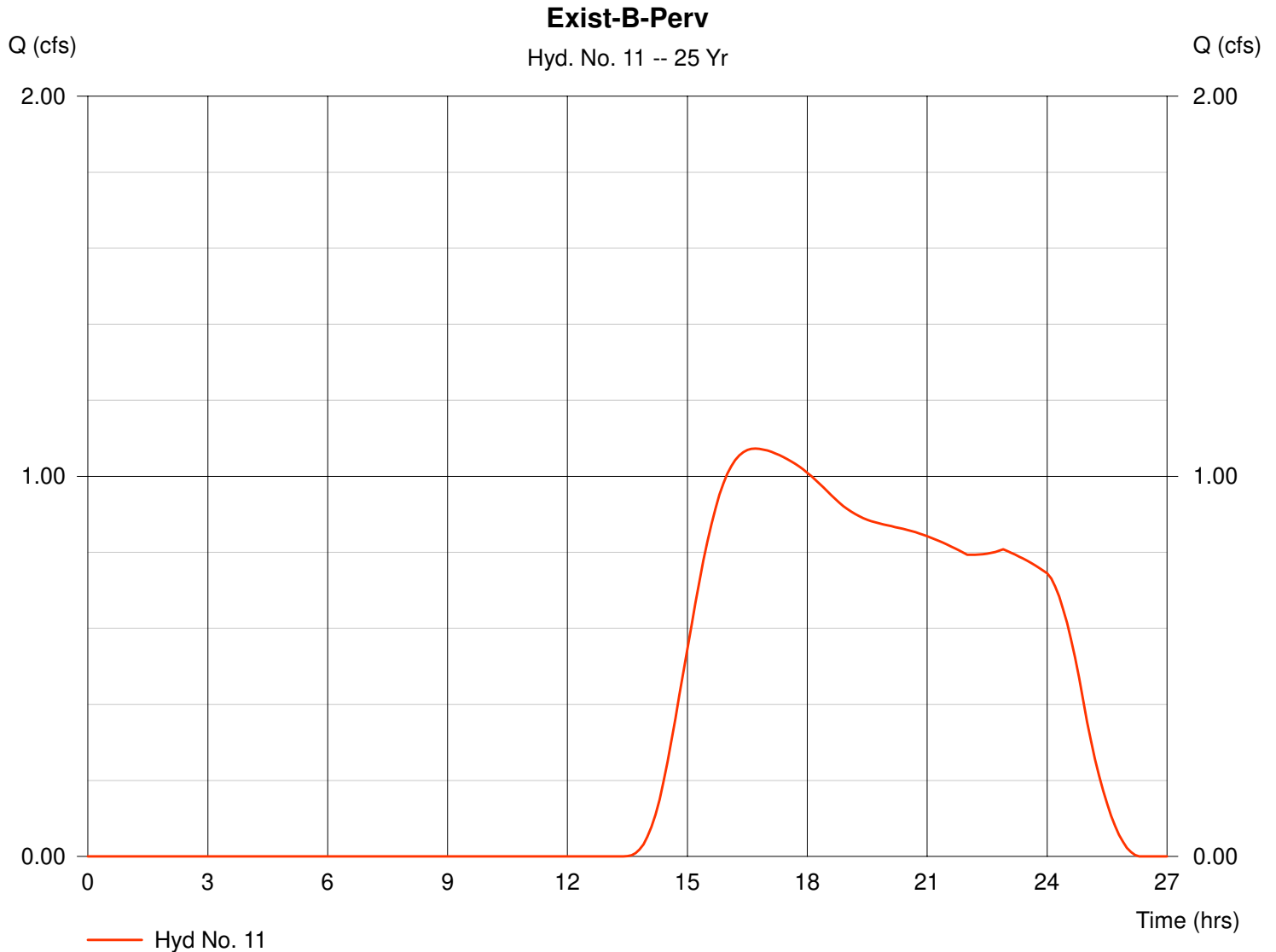

Hydrograph Plot

Hydraflow Hydrographs by Intelisolve

Tuesday, Feb 11 2020, 10:32 AM

Hyd. No. 12

Exist-B

Hydrograph type = Combine
Storm frequency = 25 yrs
Inflow hyds. = 10, 11

Peak discharge = 4.52 cfs
Time interval = 6 min

Hydrograph Volume = 81,472 cuft

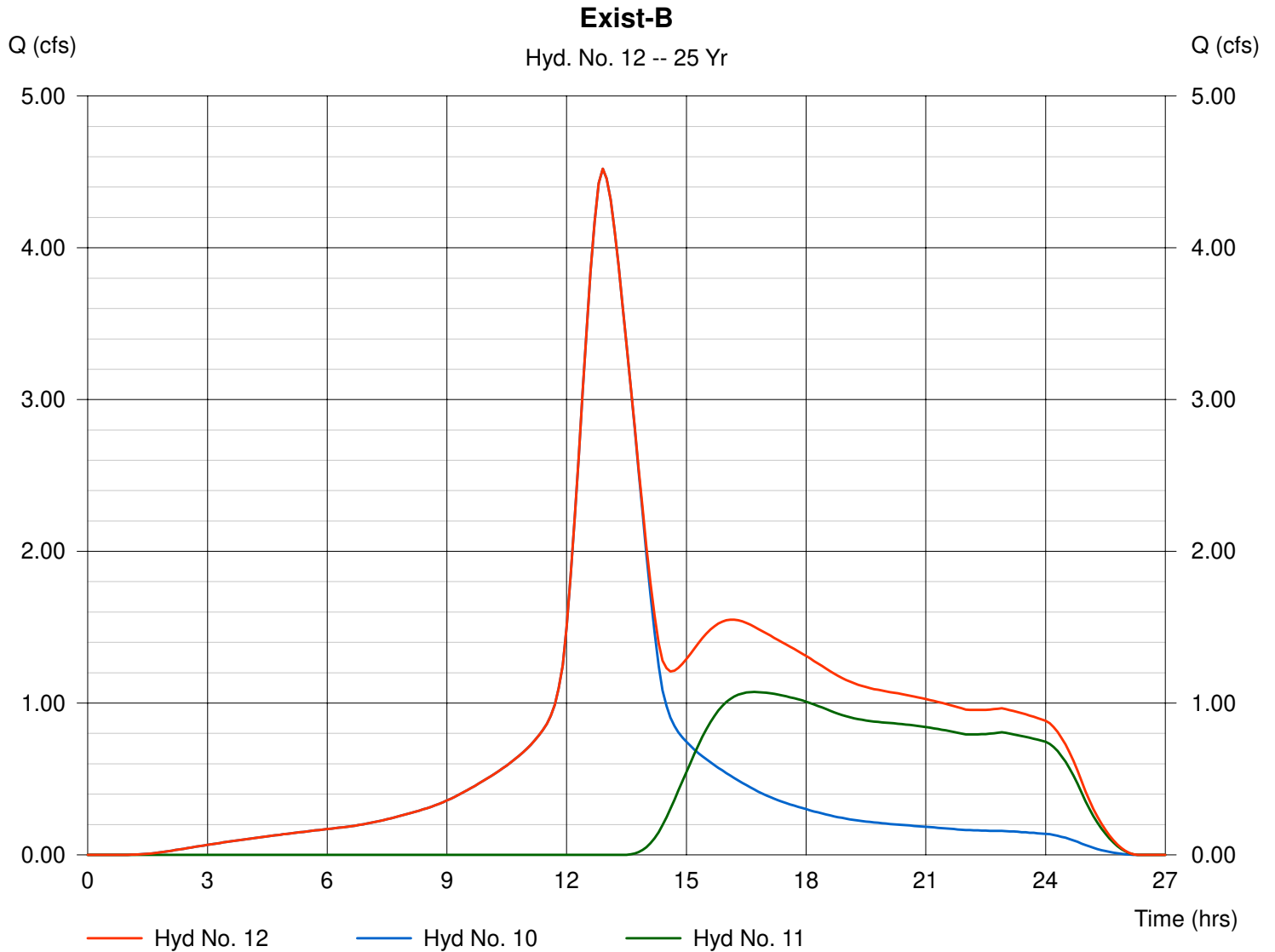

Hydrograph Plot

Hydraflow Hydrographs by Intelisolve

Tuesday, Feb 11 2020, 10:32 AM

Hyd. No. 14

Prop-B-Imp

Hydrograph type = SCS Runoff
Storm frequency = 25 yrs
Drainage area = 0.12 ac
Basin Slope = 0.0 %
Tc method = USER
Total precip. = 6.00 in
Storm duration = 24 hrs

Peak discharge = 0.23 cfs
Time interval = 6 min
Curve number = 98
Hydraulic length = 0 ft
Time of conc. (Tc) = 82.7 min
Distribution = Type III
Shape factor = 484

Hydrograph Volume = 2,510 cuft

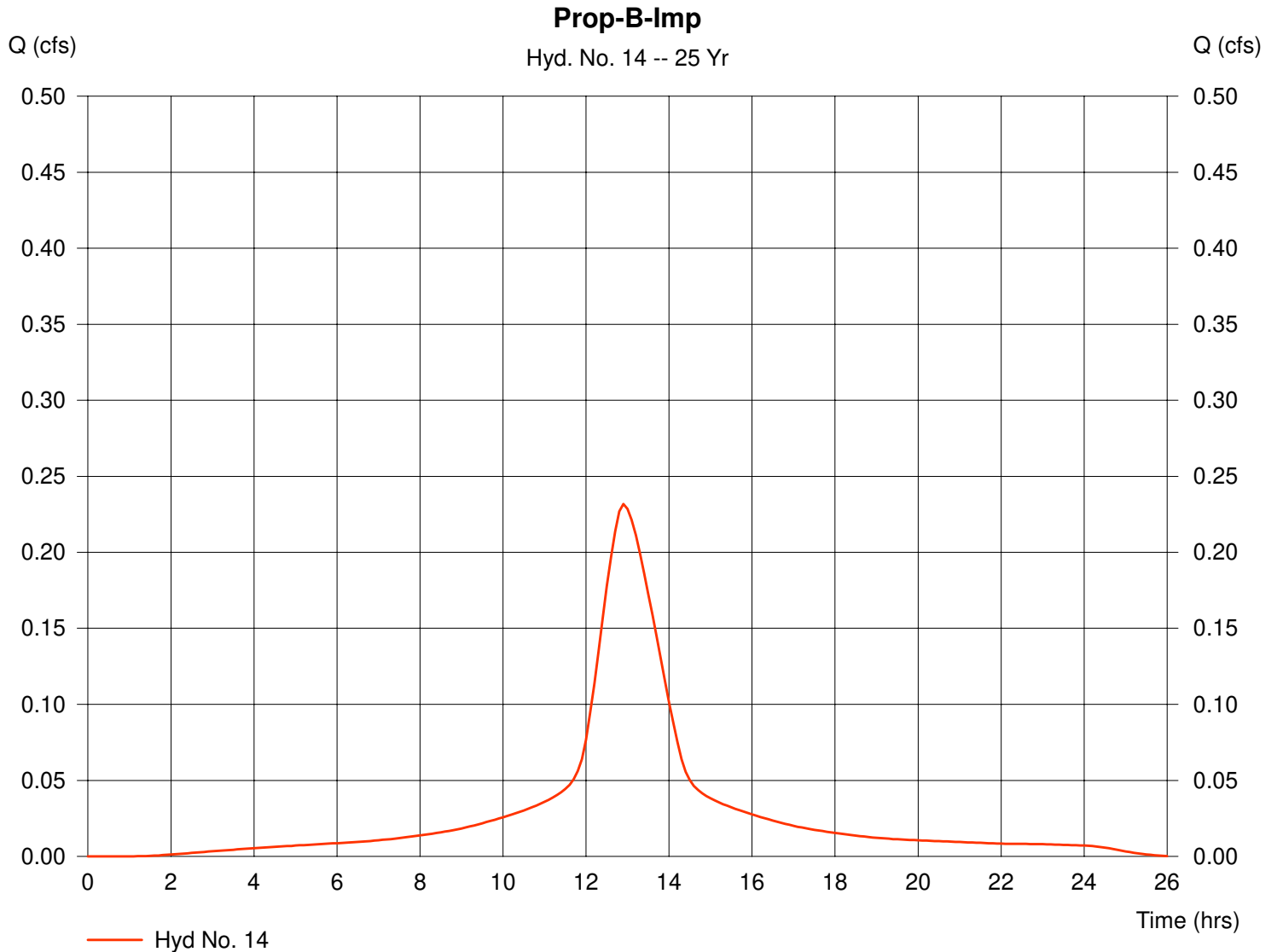

Hydrograph Plot

Hydraflow Hydrographs by Intelisolve

Tuesday, Feb 11 2020, 10:32 AM

Hyd. No. 15

Prop-B-Perv

Hydrograph type = SCS Runoff
 Storm frequency = 25 yrs
 Drainage area = 38.41 ac
 Basin Slope = 0.0 %
 Tc method = USER
 Total precip. = 6.00 in
 Storm duration = 24 hrs

Peak discharge = 0.49 cfs
 Time interval = 6 min
 Curve number = 31
 Hydraulic length = 0 ft
 Time of conc. (Tc) = 82.7 min
 Distribution = Type III
 Shape factor = 484

Hydrograph Volume = 14,042 cuft

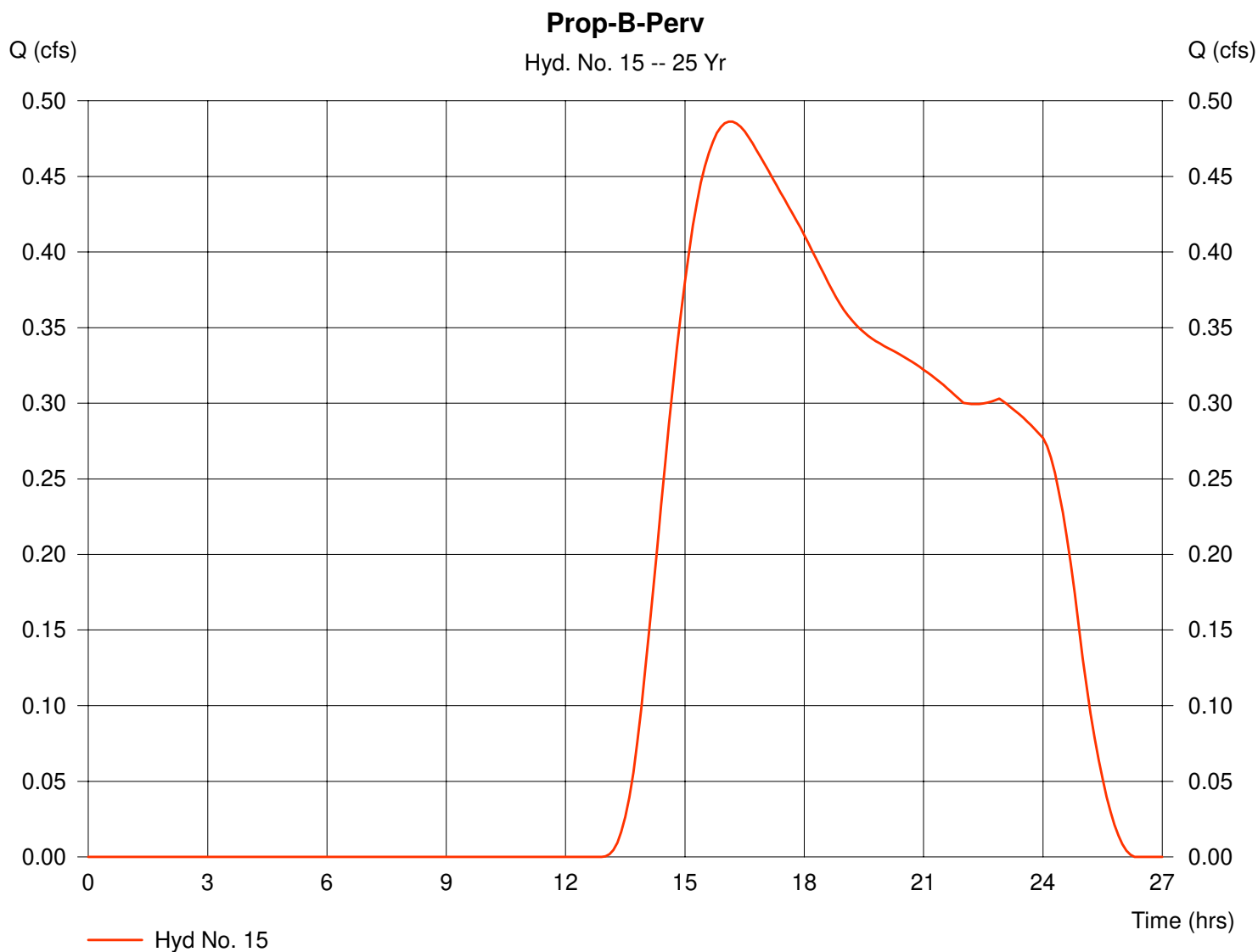

Hydrograph Plot

Hydraflow Hydrographs by Intelisolve

Tuesday, Feb 11 2020, 10:32 AM

Hyd. No. 17

Prop-B-Imp-FAN-Basin

Hydrograph type = SCS Runoff
 Storm frequency = 25 yrs
 Drainage area = 0.63 ac
 Basin Slope = 0.0 %
 Tc method = USER
 Total precip. = 6.00 in
 Storm duration = 24 hrs

Peak discharge = 1.21 cfs
 Time interval = 6 min
 Curve number = 98
 Hydraulic length = 0 ft
 Time of conc. (Tc) = 82.7 min
 Distribution = Type III
 Shape factor = 484

Hydrograph Volume = 13,093 cuft

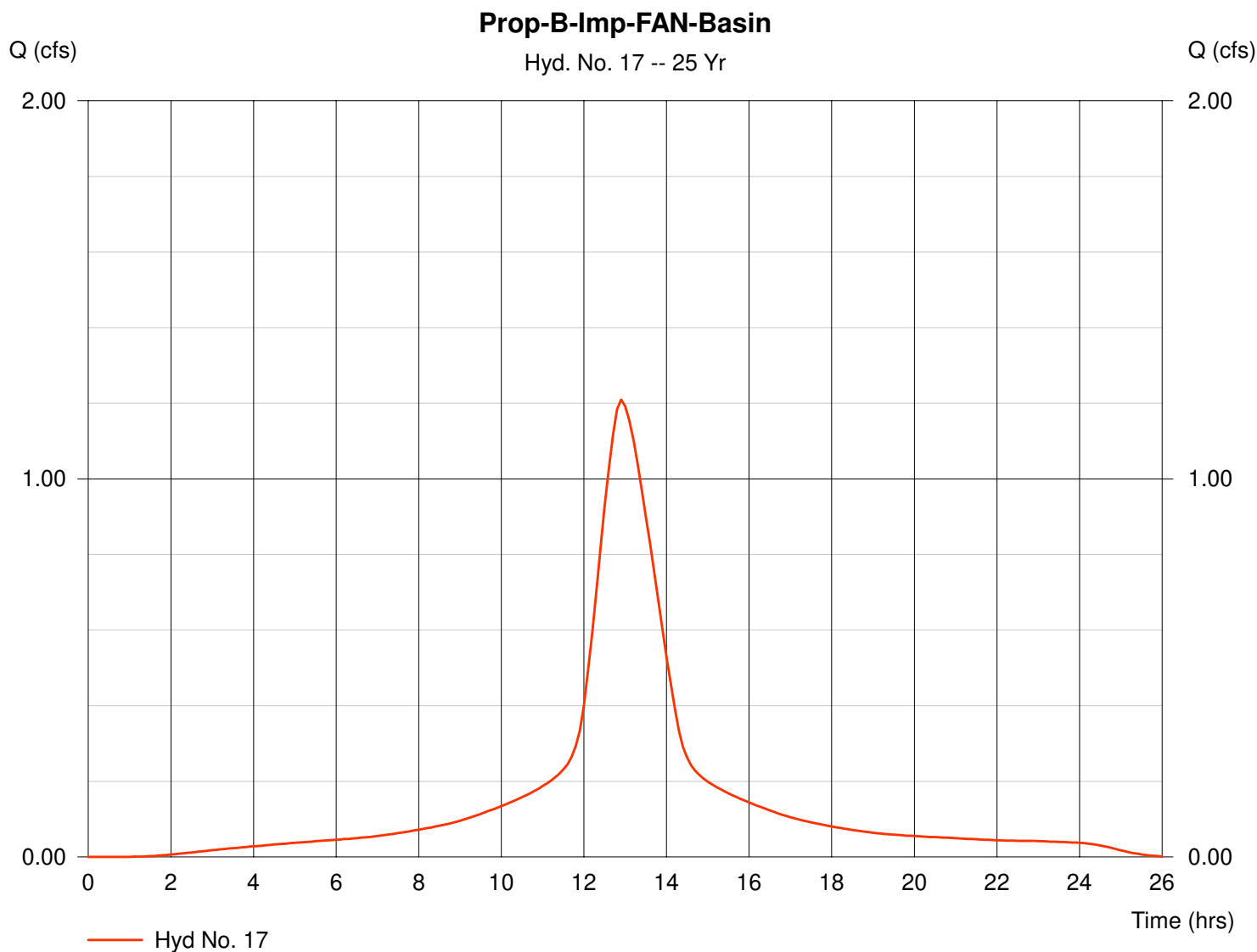

Hydrograph Plot

Hydraflow Hydrographs by Intelisolve

Tuesday, Feb 11 2020, 10:32 AM

Hyd. No. 18

Prop-B-Perv-FAN-Basin

Hydrograph type = SCS Runoff
Storm frequency = 25 yrs
Drainage area = 83.82 ac
Basin Slope = 0.0 %
Tc method = USER
Total precip. = 6.00 in
Storm duration = 24 hrs

Peak discharge = 1.45 cfs
Time interval = 6 min
Curve number = 32
Hydraulic length = 0 ft
Time of conc. (Tc) = 82.7 min
Distribution = Type III
Shape factor = 484

Hydrograph Volume = 40,500 cuft

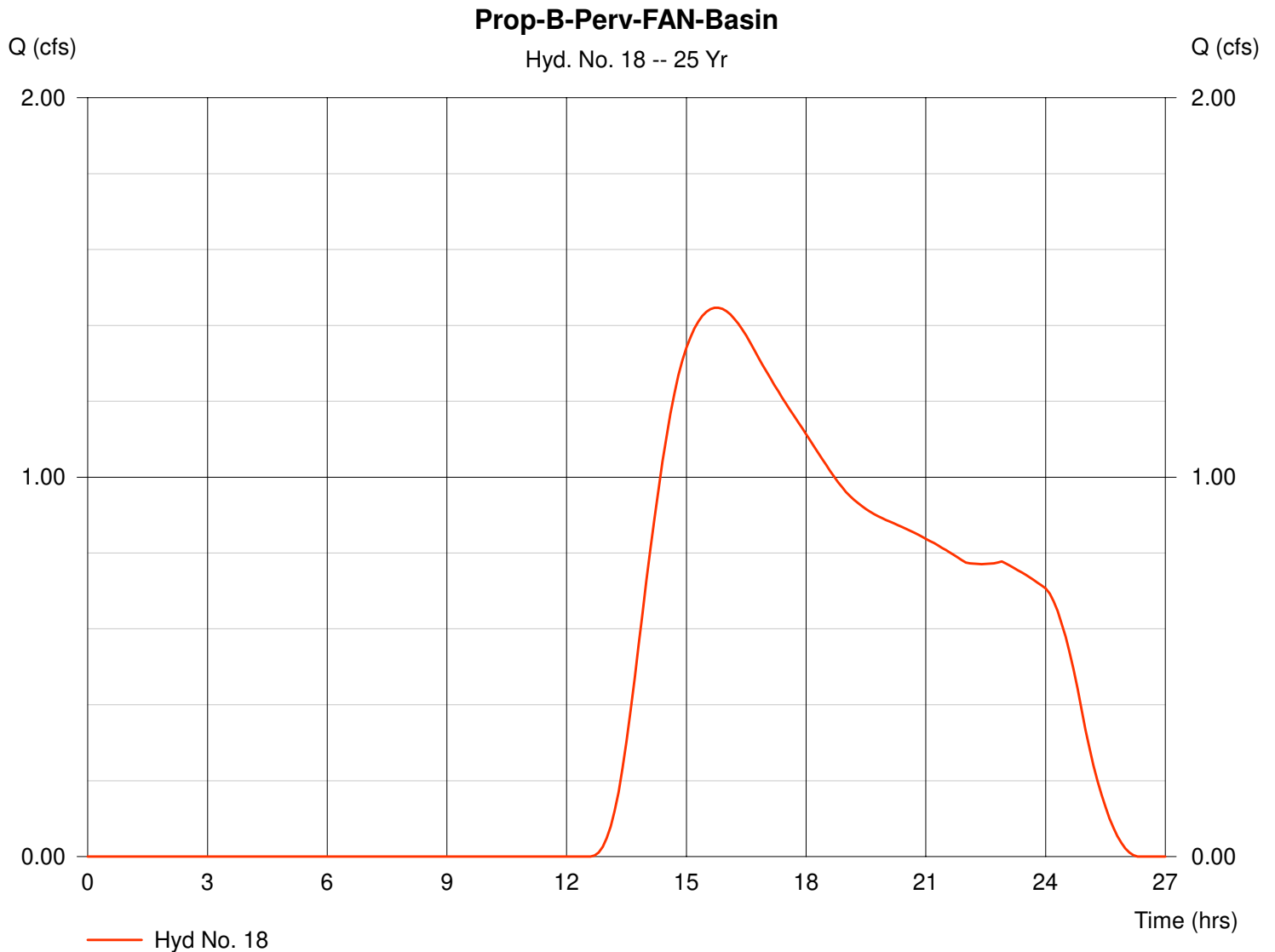

Hydrograph Plot

Hydraflow Hydrographs by Intelisolve

Tuesday, Feb 11 2020, 10:32 AM

Hyd. No. 19

FAN Basin Inflow

Hydrograph type = Combine
Storm frequency = 25 yrs
Inflow hyds. = 17, 18

Peak discharge = 1.61 cfs
Time interval = 6 min

Hydrograph Volume = 53,593 cuft

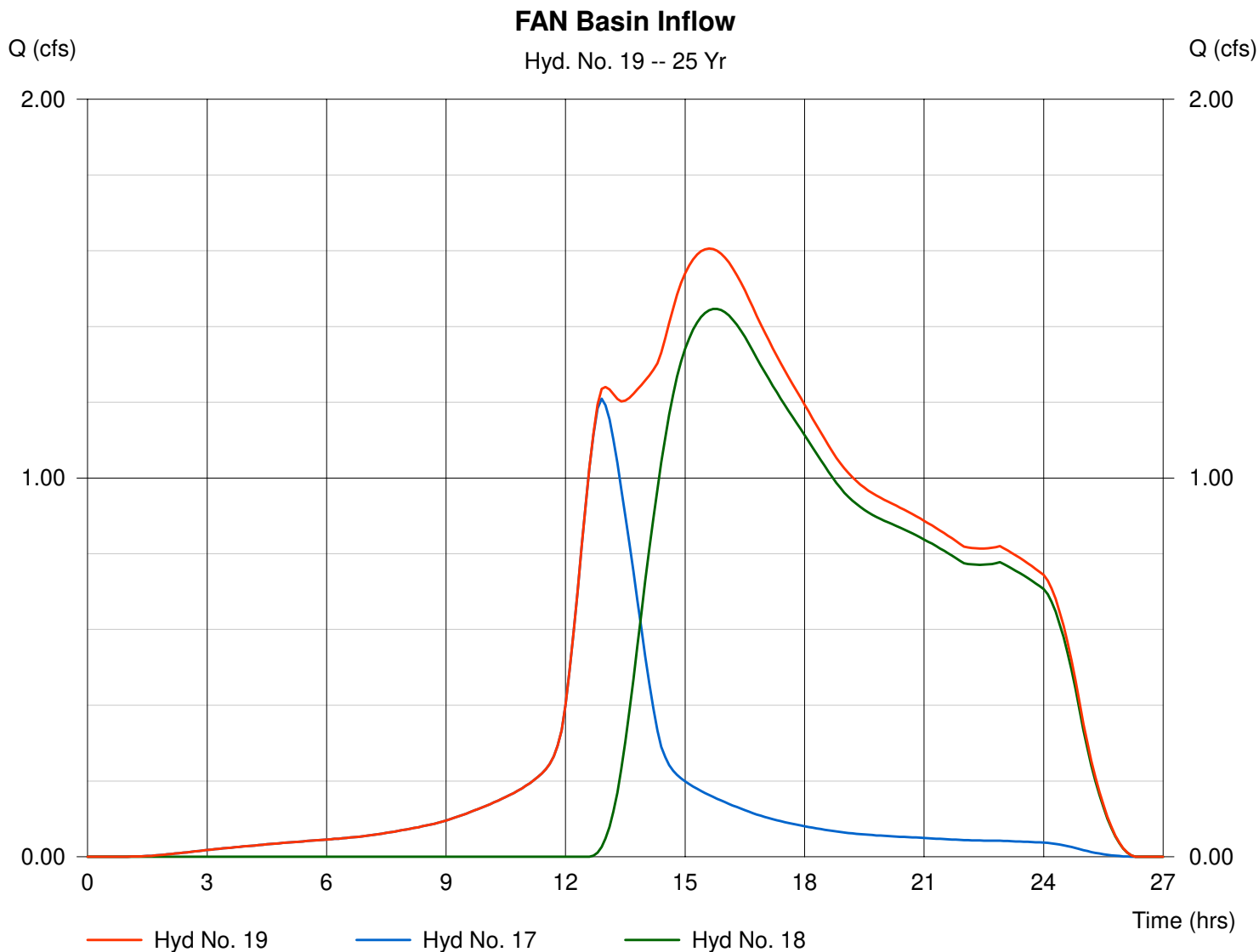

Hydrograph Plot

Hydraflow Hydrographs by Intelisolve

Tuesday, Feb 11 2020, 10:32 AM

Hyd. No. 20

FAN Basin 1 Routing

Hydrograph type = Reservoir
 Storm frequency = 25 yrs
 Inflow hyd. No. = 19
 Reservoir name = FAN Basin

Peak discharge = 0.68 cfs
 Time interval = 6 min
 Max. Elevation = 155.12 ft
 Max. Storage = 32,583 cuft

Storage Indication method used.

Hydrograph Volume = 31,344 cuft

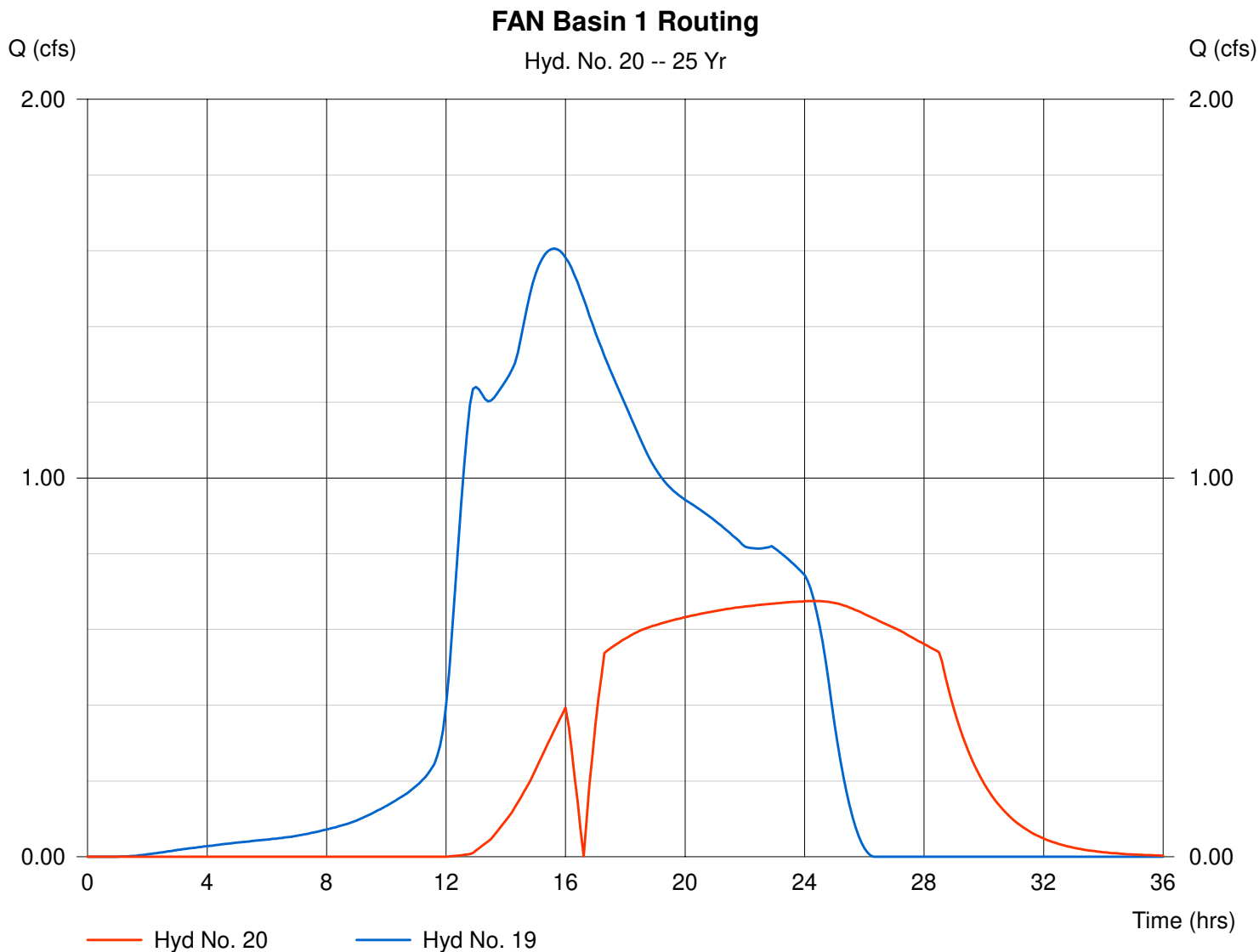

Pond Report

Hydraflow Hydrographs by Intelisolve

Tuesday, Feb 11 2020, 10:32 AM

Pond No. 1 - FAN Basin

Pond Data

Pond storage is based on known contour areas. Average end area method used.

Stage / Storage Table

Stage (ft)	Elevation (ft)	Contour area (sqft)	Incr. Storage (cuft)	Total storage (cuft)
0.00	154.25	36,091	0	0
0.75	155.00	38,058	27,806	27,806
1.75	156.00	40,796	39,427	67,233
2.75	157.00	43,656	42,226	109,459

Culvert / Orifice Structures

	[A]	[B]	[C]	[D]
Rise (in)	= 18.00	6.00	0.00	0.00
Span (in)	= 18.00	6.00	0.00	0.00
No. Barrels	= 1	1	0	0
Invert El. (ft)	= 154.25	154.35	0.00	0.00
Length (ft)	= 38.00	0.00	0.00	0.00
Slope (%)	= 3.30	0.00	0.00	0.00
N-Value	= .013	.013	.013	.000
Orif. Coeff.	= 0.60	0.60	0.60	0.00
Multi-Stage	= n/a	Yes	No	No

Weir Structures

	[A]	[B]	[C]	[D]
Crest Len (ft)	= 16.00	2.00	0.00	0.00
Crest El. (ft)	= 156.50	156.00	0.00	0.00
Weir Coeff.	= 3.33	3.33	3.33	0.00
Weir Type	= Riser	Rect	---	---
Multi-Stage	= Yes	Yes	No	No

Exfiltration = 0.000 in/hr (Contour) Tailwater Elev. = 0.00 ft

Note: Culvert/Orifice outflows have been analyzed under inlet and outlet control.

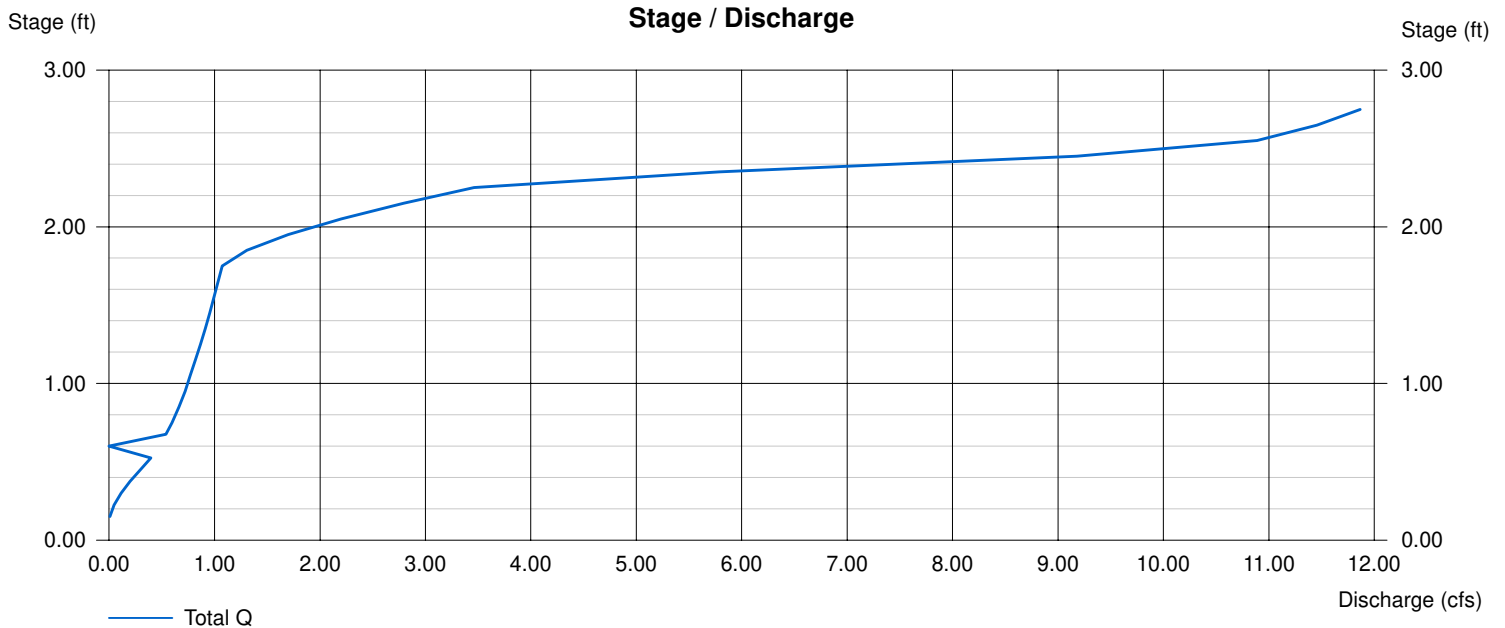

Hydrograph Plot

Hydraflow Hydrographs by Intelisolve

Tuesday, Feb 11 2020, 10:32 AM

Hyd. No. 21

Prop-B-Imp-ROCA-Basin

Hydrograph type = SCS Runoff
Storm frequency = 25 yrs
Drainage area = 0.20 ac
Basin Slope = 0.0 %
Tc method = USER
Total precip. = 6.00 in
Storm duration = 24 hrs

Peak discharge = 0.39 cfs
Time interval = 6 min
Curve number = 98
Hydraulic length = 0 ft
Time of conc. (Tc) = 82.7 min
Distribution = Type III
Shape factor = 484

Hydrograph Volume = 4,183 cuft

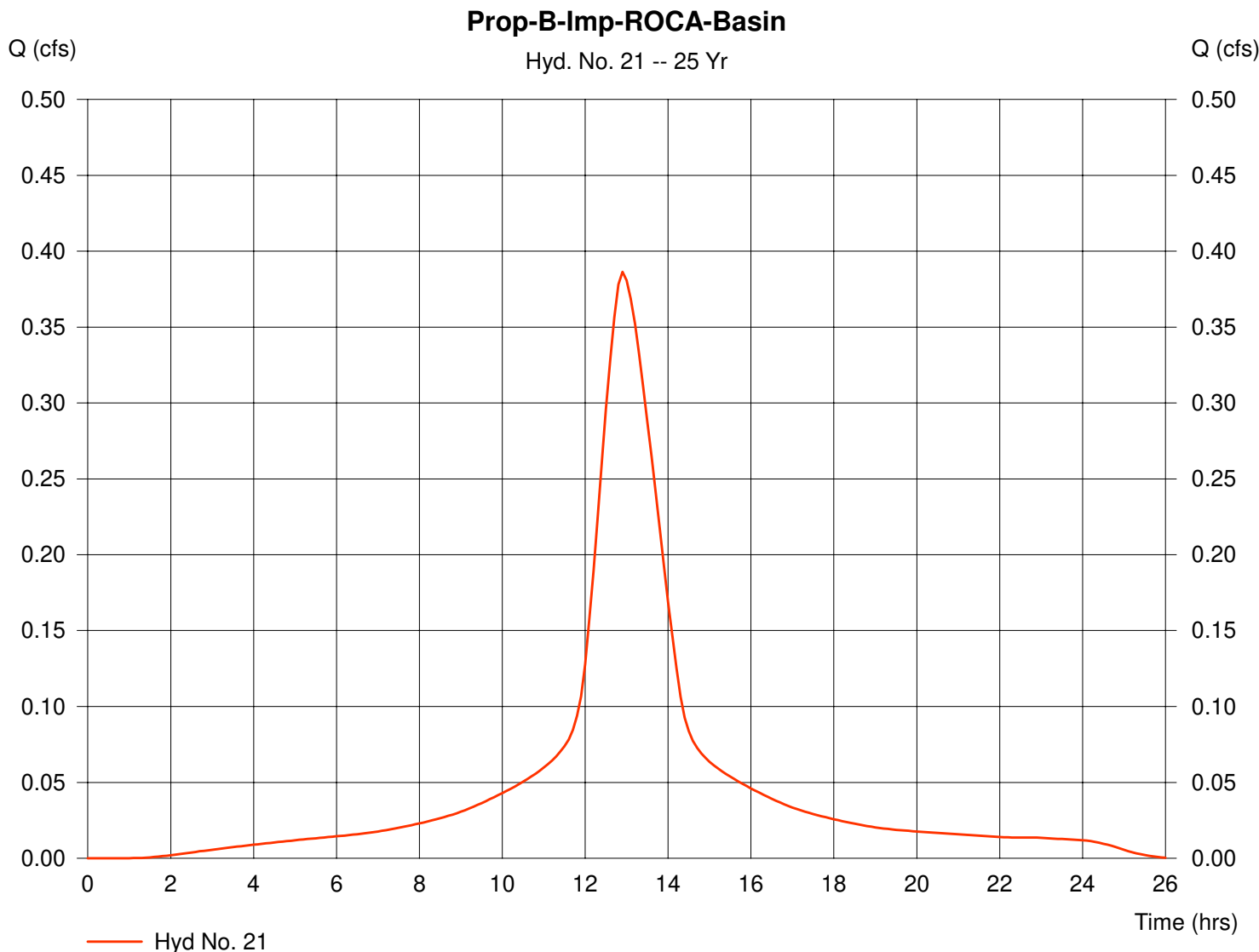

Hydrograph Plot

Hydraflow Hydrographs by Intelisolve

Tuesday, Feb 11 2020, 10:32 AM

Hyd. No. 22

Prop-B-Perv-ROCA-Basin

Hydrograph type = SCS Runoff
 Storm frequency = 25 yrs
 Drainage area = 10.79 ac
 Basin Slope = 0.0 %
 Tc method = USER
 Total precip. = 6.00 in
 Storm duration = 24 hrs

Peak discharge = 0.73 cfs
 Time interval = 6 min
 Curve number = 38
 Hydraulic length = 0 ft
 Time of conc. (Tc) = 82.7 min
 Distribution = Type III
 Shape factor = 484

Hydrograph Volume = 15,261 cuft

Prop-B-Perv-ROCA-Basin

Hyd. No. 22 -- 25 Yr

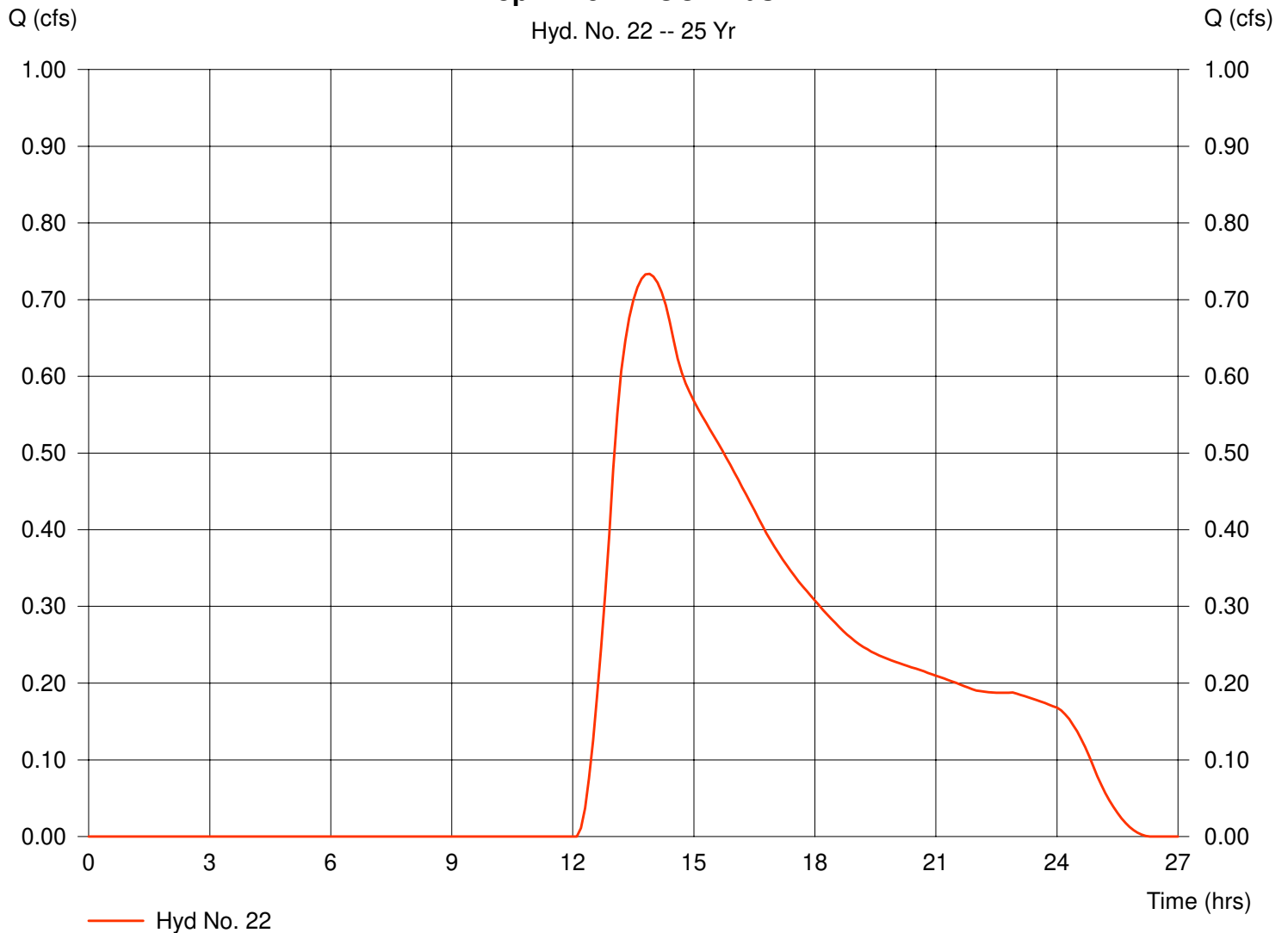

Hydrograph Plot

Hydraflow Hydrographs by Intelisolve

Tuesday, Feb 11 2020, 10:32 AM

Hyd. No. 23

ROCA Basin Inflow

Hydrograph type = Combine
Storm frequency = 25 yrs
Inflow hyds. = 21, 22

Peak discharge = 0.99 cfs
Time interval = 6 min

Hydrograph Volume = 19,444 cuft

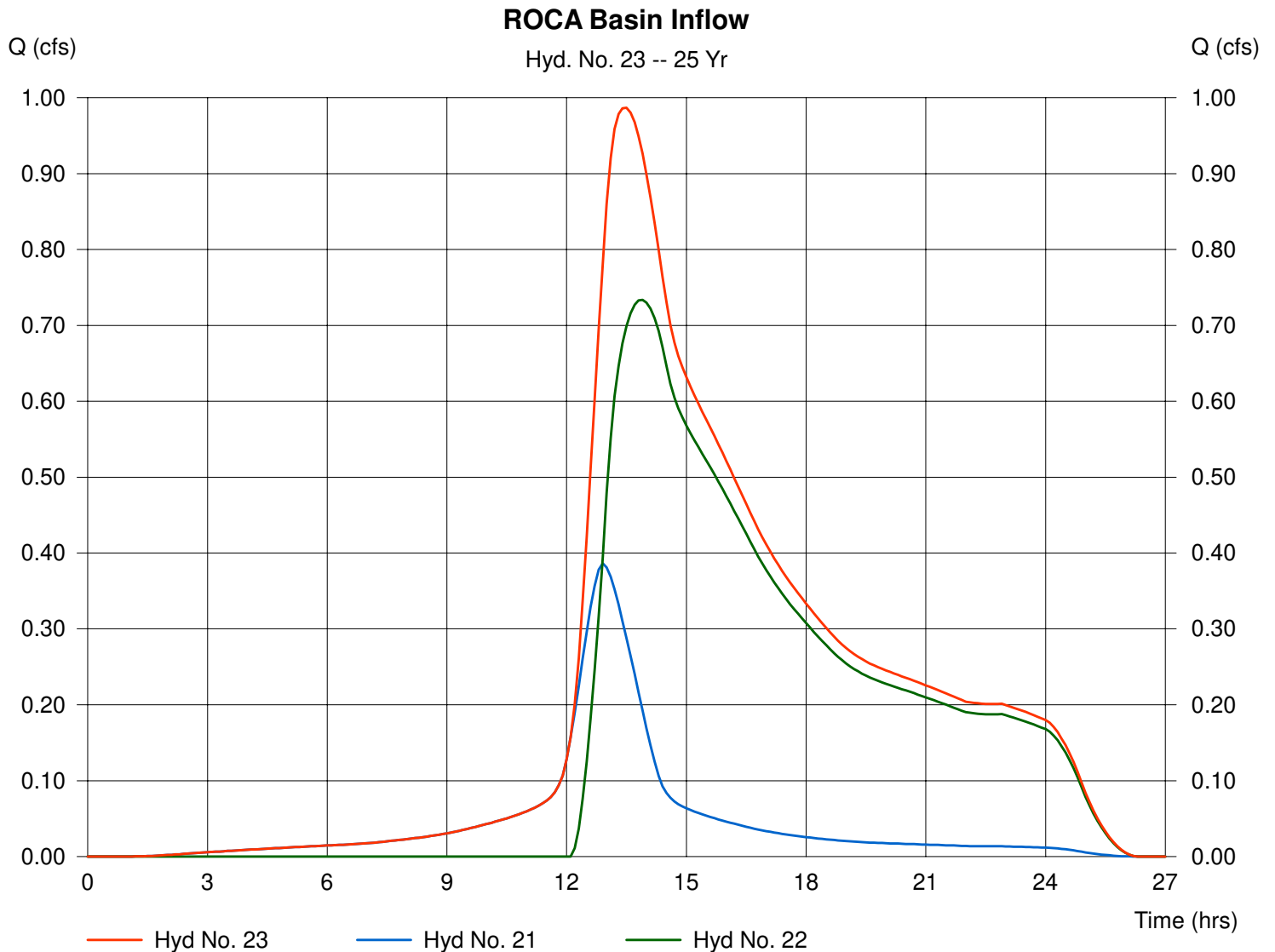

Hydrograph Plot

Hydraflow Hydrographs by Intelisolve

Tuesday, Feb 11 2020, 10:32 AM

Hyd. No. 24

ROCA Basin Routing

Hydrograph type = Reservoir
Storm frequency = 25 yrs
Inflow hyd. No. = 23
Reservoir name = ROCA Basin

Peak discharge = 0.49 cfs
Time interval = 6 min
Max. Elevation = 155.12 ft
Max. Storage = 6,745 cuft

Storage Indication method used.

Hydrograph Volume = 18,317 cuft

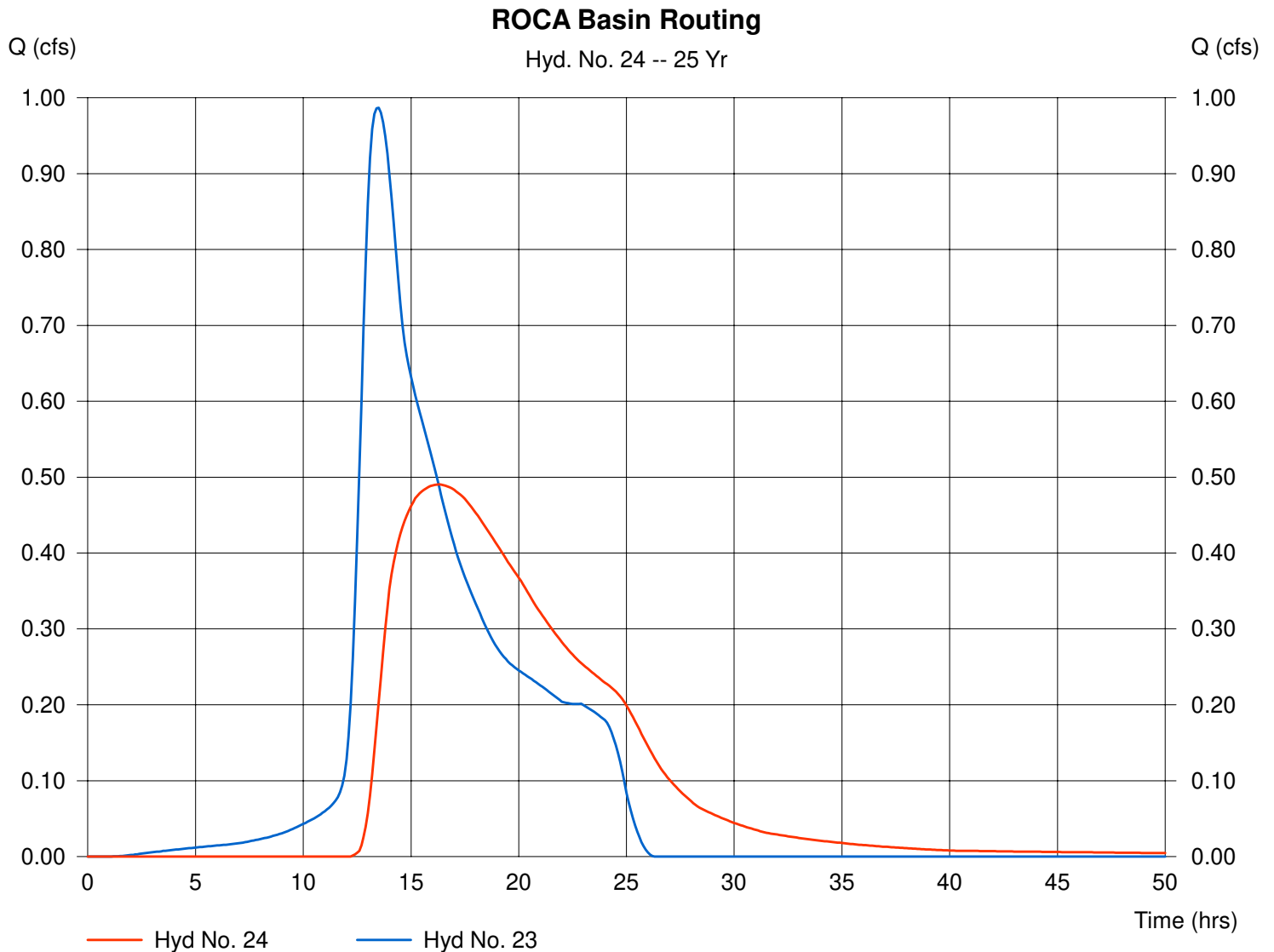

Pond Report

Hydraflow Hydrographs by Intelisolve

Tuesday, Feb 11 2020, 10:32 AM

Pond No. 2 - ROCA Basin

Pond Data

Pond storage is based on known contour areas. Average end area method used.

Stage / Storage Table

Stage (ft)	Elevation (ft)	Contour area (sqft)	Incr. Storage (cuft)	Total storage (cuft)
0.00	154.50	10,126	0	0
0.50	155.00	11,053	5,295	5,295
1.50	156.00	13,036	12,045	17,339
2.00	156.50	14,055	6,773	24,112

Culvert / Orifice Structures

	[A]	[B]	[C]	[D]
Rise (in)	= 18.00	6.00	0.00	0.00
Span (in)	= 18.00	6.00	0.00	0.00
No. Barrels	= 1	1	0	0
Invert El. (ft)	= 154.50	154.60	0.00	0.00
Length (ft)	= 115.00	0.00	0.00	0.00
Slope (%)	= 1.30	0.00	0.00	0.00
N-Value	= .013	.013	.000	.000
Orif. Coeff.	= 0.60	0.60	0.00	0.00
Multi-Stage	= n/a	Yes	No	No

Weir Structures

	[A]	[B]	[C]	[D]
Crest Len (ft)	= 16.00	0.00	0.00	0.00
Crest El. (ft)	= 156.50	0.00	0.00	0.00
Weir Coeff.	= 3.33	3.33	0.00	0.00
Weir Type	= Riser	---	---	---
Multi-Stage	= Yes	No	No	No

Exfiltration = 0.000 in/hr (Contour) Tailwater Elev. = 0.00 ft

Note: Culvert/Orifice outflows have been analyzed under inlet and outlet control.

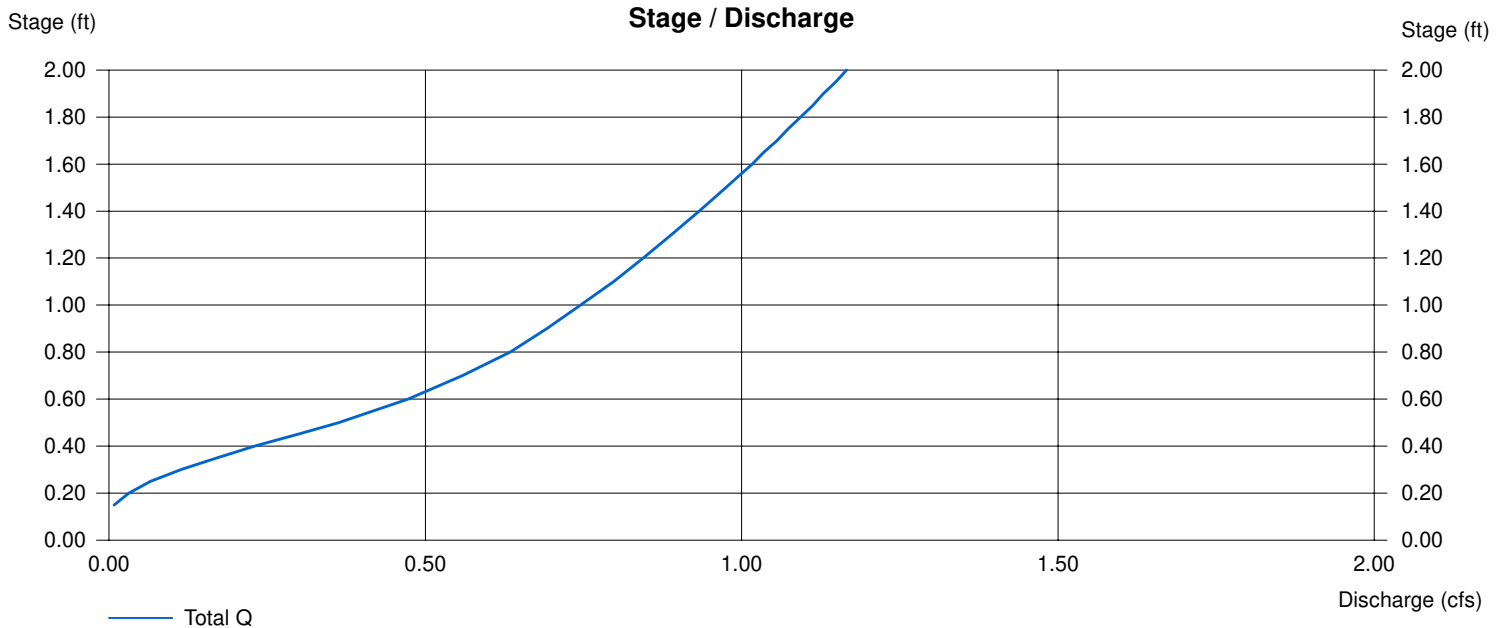

Hydrograph Plot

Hydraflow Hydrographs by Intelisolve

Tuesday, Feb 11 2020, 10:32 AM

Hyd. No. 25

Prop-B

Hydrograph type = Combine
Storm frequency = 25 yrs
Inflow hyds. = 14, 15

Peak discharge = 0.51 cfs
Time interval = 6 min

Hydrograph Volume = 16,551 cuft

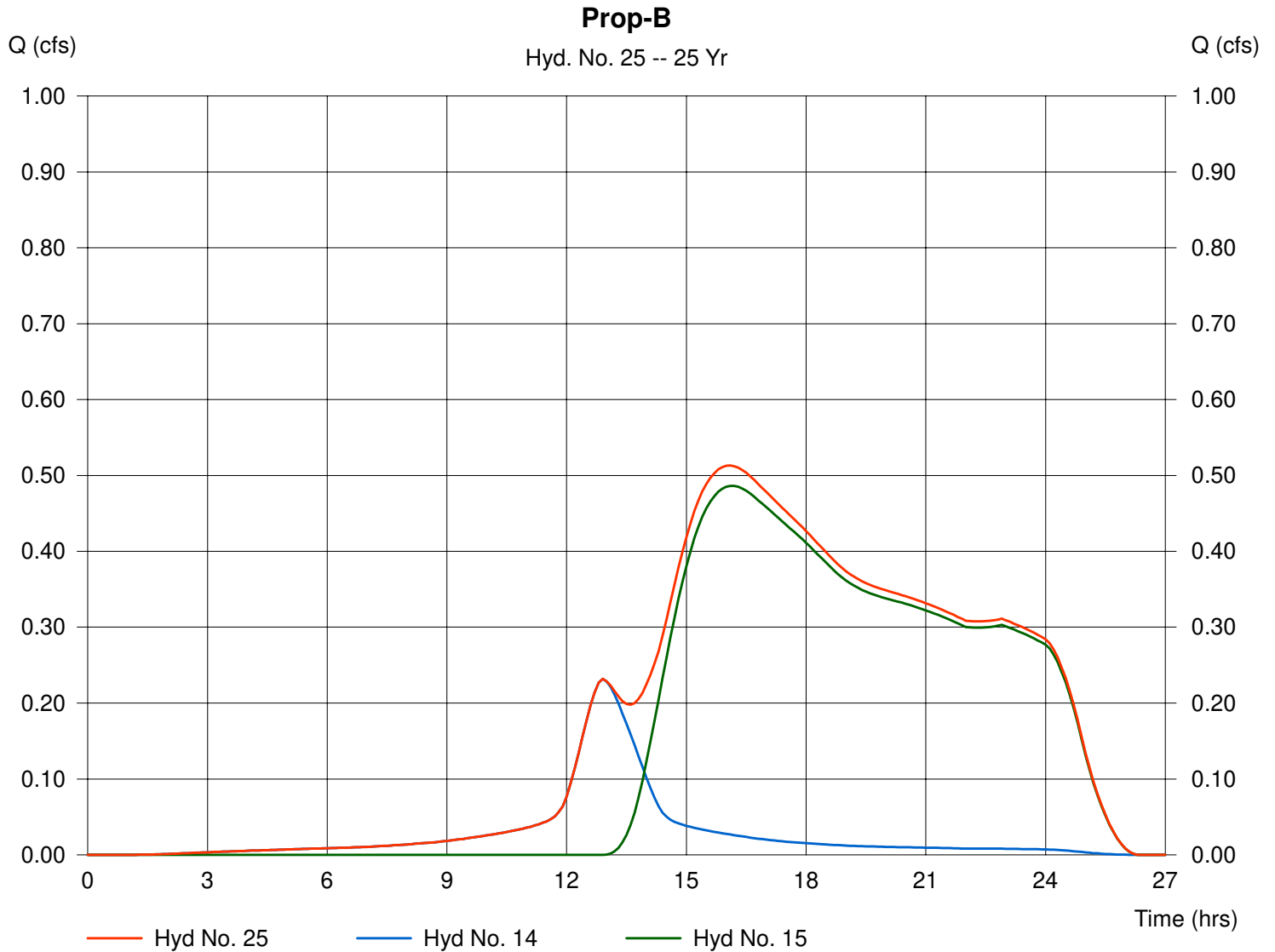

Hydrograph Plot

Hydraflow Hydrographs by Intelisolve

Tuesday, Feb 11 2020, 10:32 AM

Hyd. No. 26

Prop-B

Hydrograph type = Combine
Storm frequency = 25 yrs
Inflow hyds. = 20, 24, 25

Peak discharge = 1.48 cfs
Time interval = 6 min

Hydrograph Volume = 66,212 cuft

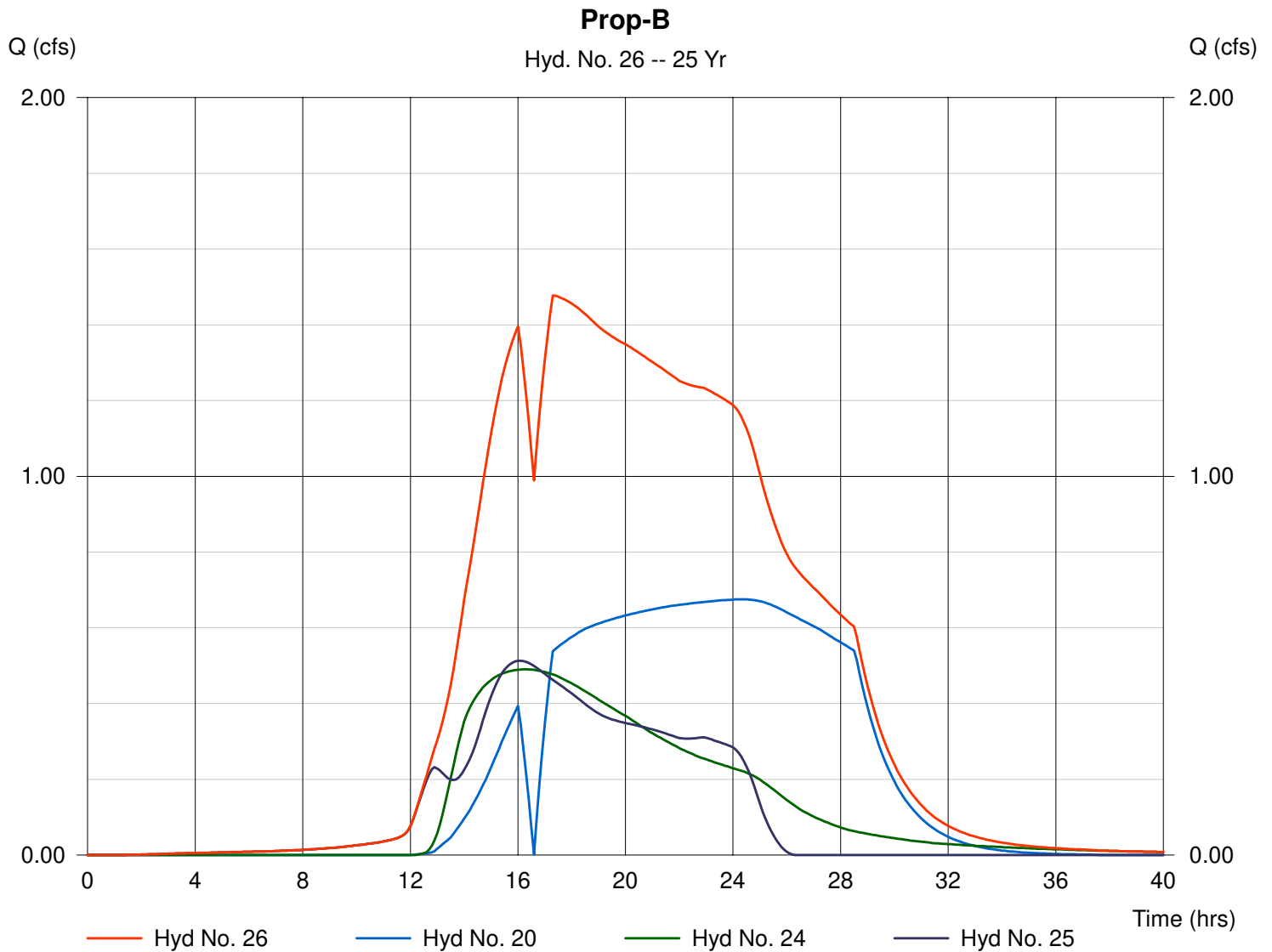

Hydrograph Plot

Hydraflow Hydrographs by Intelisolve

Tuesday, Feb 11 2020, 10:32 AM

Hyd. No. 29

Exist-C-Imp

Hydrograph type = SCS Runoff
Storm frequency = 25 yrs
Drainage area = 1.66 ac
Basin Slope = 0.0 %
Tc method = USER
Total precip. = 6.00 in
Storm duration = 24 hrs

Peak discharge = 3.43 cfs
Time interval = 6 min
Curve number = 98
Hydraulic length = 0 ft
Time of conc. (Tc) = 76.33 min
Distribution = Type III
Shape factor = 484

Hydrograph Volume = 34,177 cuft

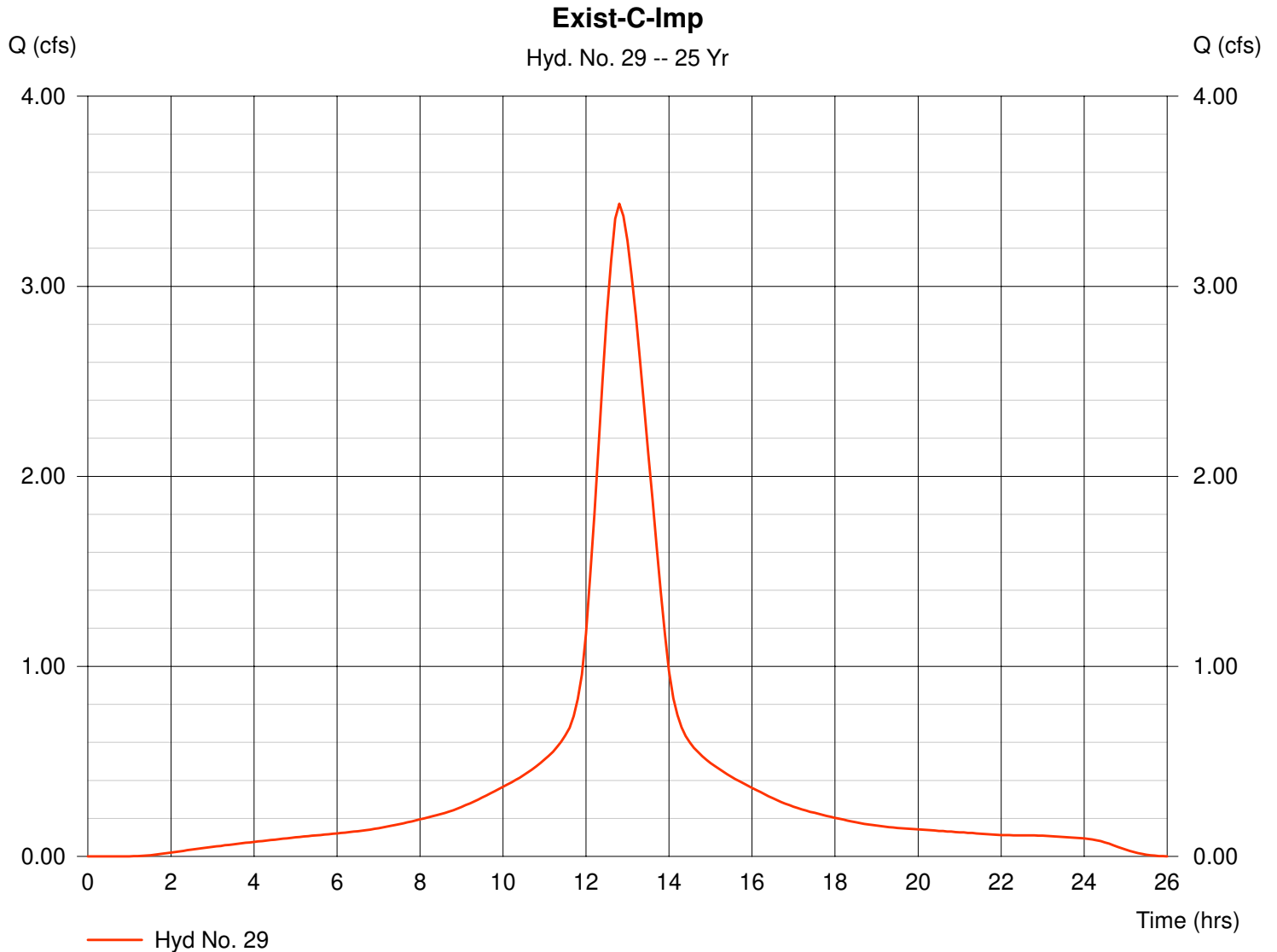

Hydrograph Plot

Hydraflow Hydrographs by Intelisolve

Tuesday, Feb 11 2020, 10:32 AM

Hyd. No. 30

Exist-C-Perv

Hydrograph type = SCS Runoff
Storm frequency = 25 yrs
Drainage area = 130.63 ac
Basin Slope = 0.0 %
Tc method = USER
Total precip. = 6.00 in
Storm duration = 24 hrs

Peak discharge = 13.61 cfs
Time interval = 6 min
Curve number = 40
Hydraulic length = 0 ft
Time of conc. (Tc) = 76.33 min
Distribution = Type III
Shape factor = 484

Hydrograph Volume = 233,389 cuft

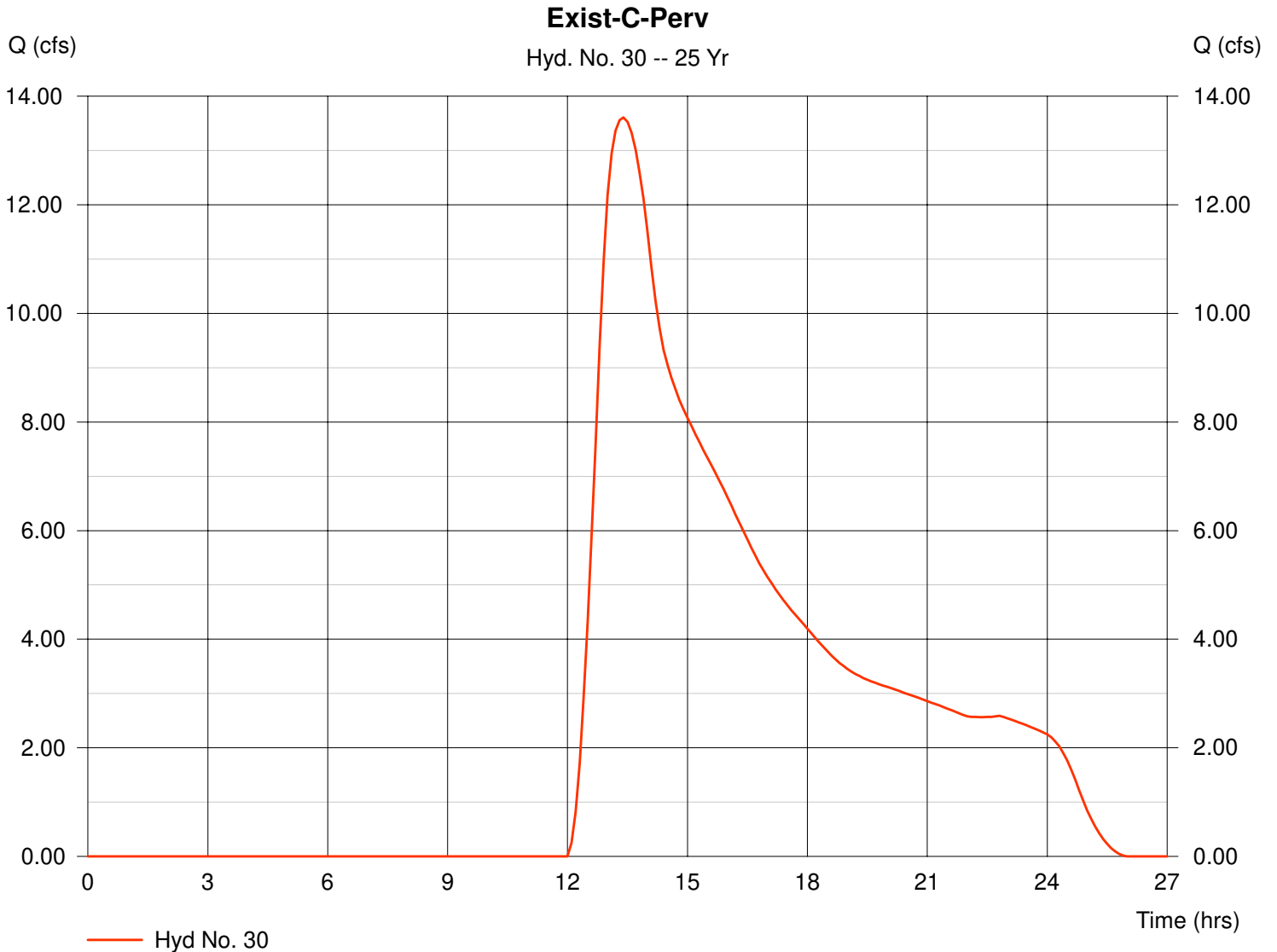

Hydrograph Plot

Hydraflow Hydrographs by Intelisolve

Tuesday, Feb 11 2020, 10:32 AM

Hyd. No. 31

Exist-C

Hydrograph type = Combine
Storm frequency = 25 yrs
Inflow hyds. = 29, 30

Peak discharge = 16.21 cfs
Time interval = 6 min

Hydrograph Volume = 267,566 cuft

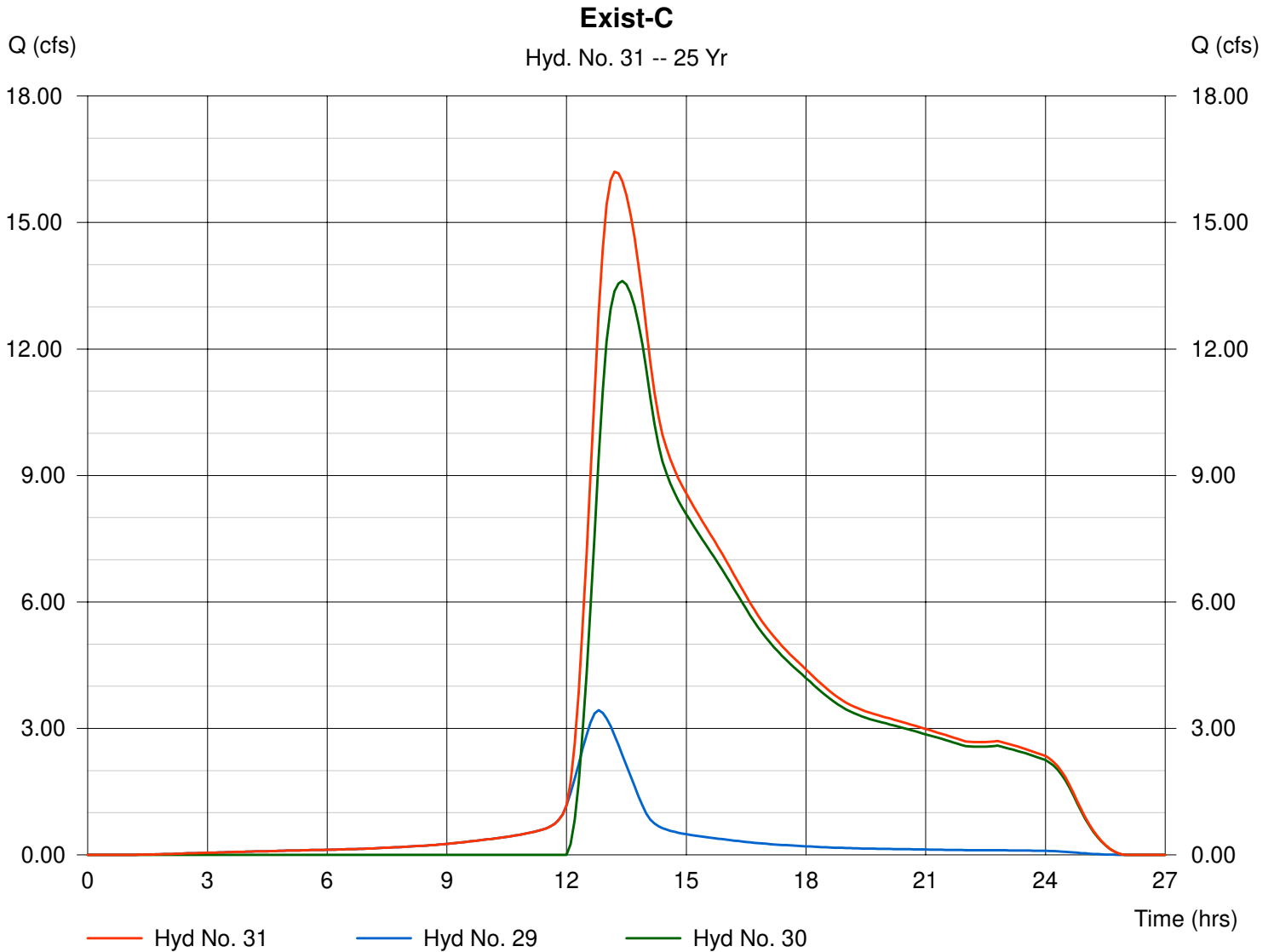

Hydrograph Plot

Hydraflow Hydrographs by Intelisolve

Tuesday, Feb 11 2020, 10:32 AM

Hyd. No. 33

Prop-C-Imp

Hydrograph type = SCS Runoff
 Storm frequency = 25 yrs
 Drainage area = 1.42 ac
 Basin Slope = 0.0 %
 Tc method = USER
 Total precip. = 6.00 in
 Storm duration = 24 hrs

Peak discharge = 2.94 cfs
 Time interval = 6 min
 Curve number = 98
 Hydraulic length = 0 ft
 Time of conc. (Tc) = 75.49 min
 Distribution = Type III
 Shape factor = 484

Hydrograph Volume = 29,236 cuft

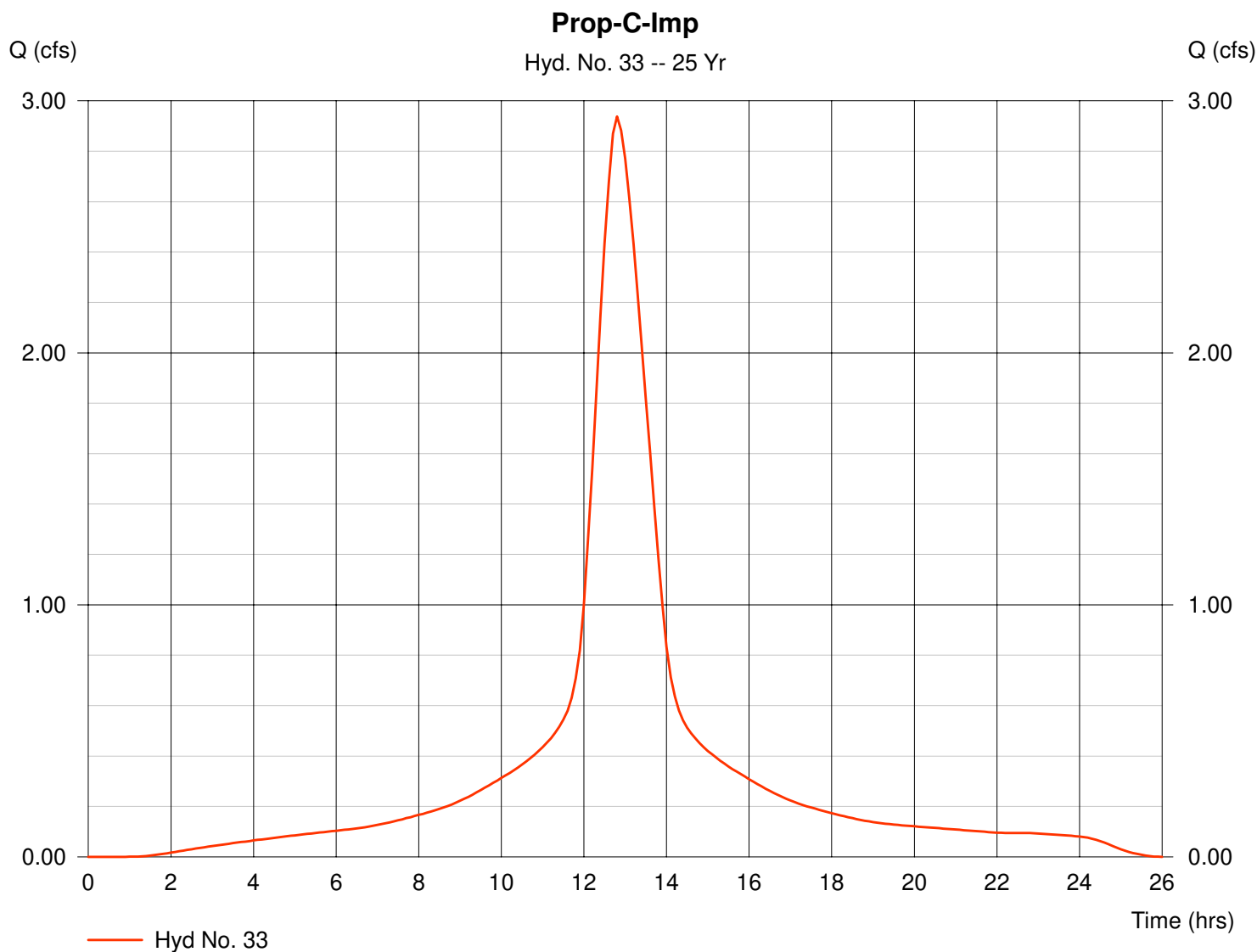

Hydrograph Plot

Hydraflow Hydrographs by Intelisolve

Tuesday, Feb 11 2020, 10:32 AM

Hyd. No. 34

Prop-C-Perv

Hydrograph type = SCS Runoff
Storm frequency = 25 yrs
Drainage area = 133.04 ac
Basin Slope = 0.0 %
Tc method = USER
Total precip. = 6.00 in
Storm duration = 24 hrs

Peak discharge = 13.86 cfs
Time interval = 6 min
Curve number = 40
Hydraulic length = 0 ft
Time of conc. (Tc) = 75.49 min
Distribution = Type III
Shape factor = 484

Hydrograph Volume = 237,695 cuft

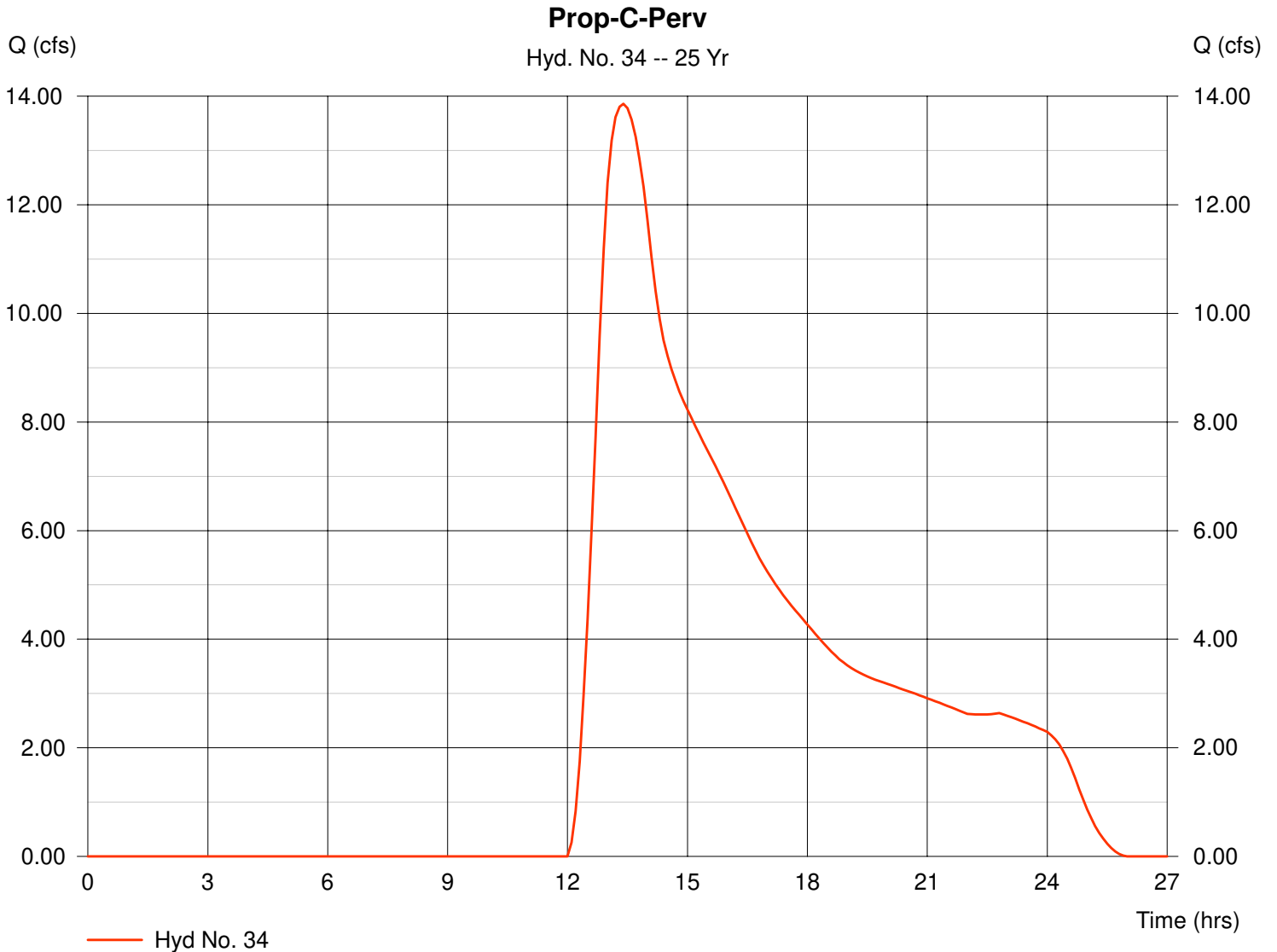

Hydrograph Plot

Hydraflow Hydrographs by Intelisolve

Tuesday, Feb 11 2020, 10:32 AM

Hyd. No. 35

Prop-C

Hydrograph type = Combine
Storm frequency = 25 yrs
Inflow hyds. = 33, 34

Peak discharge = 16.04 cfs
Time interval = 6 min

Hydrograph Volume = 266,931 cuft

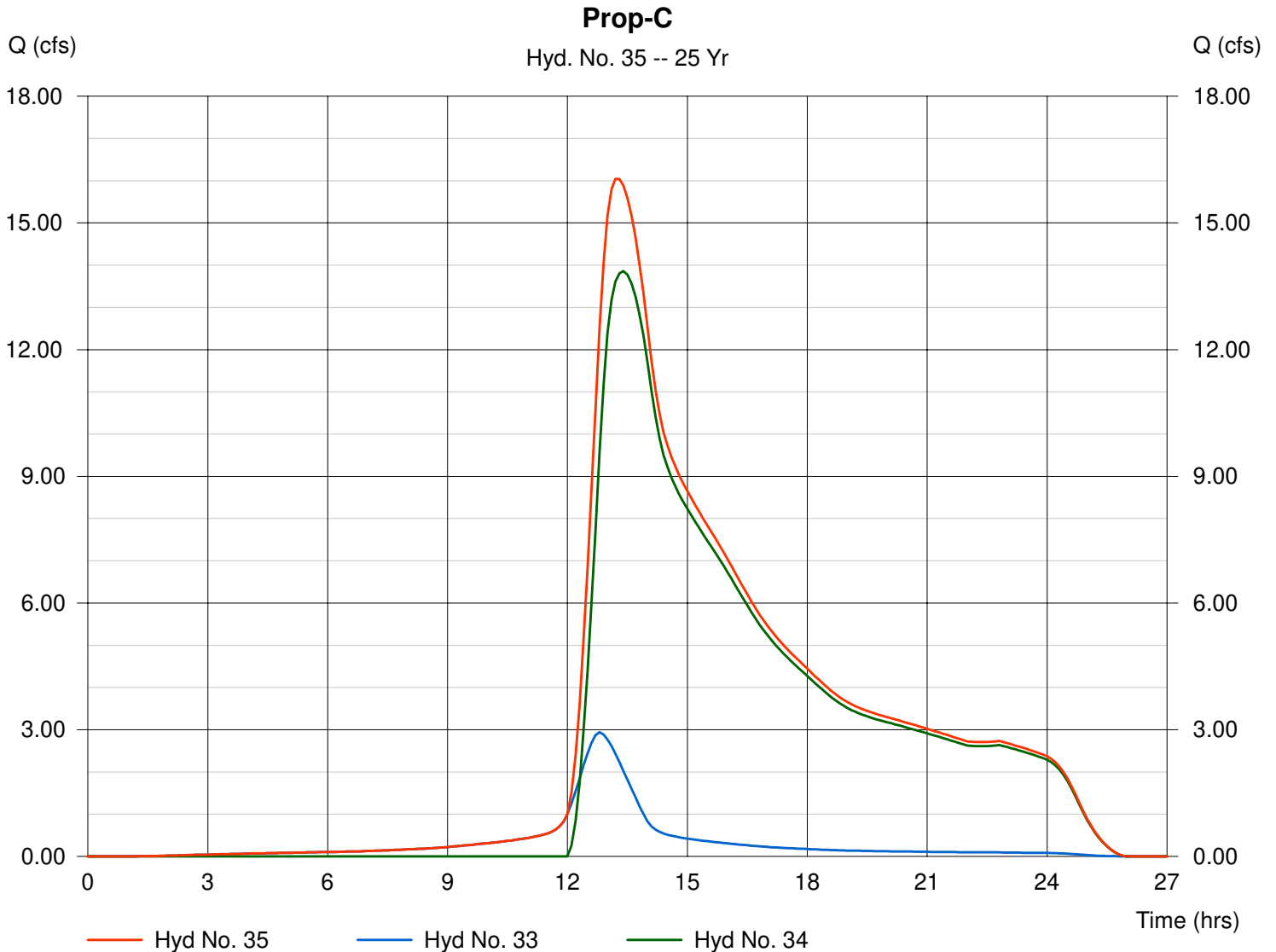

Hydrograph Summary Report

Hyd. No.	Hydrograph type (origin)	Peak flow (cfs)	Time interval (min)	Time to peak (min)	Volume (cuft)	Inflow hyd(s)	Maximum elevation (ft)	Maximum storage (cuft)	Hydrograph description
1	SCS Runoff	5.39	6	780	63,177	---	-----	-----	Exist-A-Imp
2	SCS Runoff	17.36	6	822	308,103	---	-----	-----	Exist-A-Perv
3	Combine	21.75	6	804	371,280	1, 2	-----	-----	Exist-A
5	SCS Runoff	5.20	6	774	56,489	---	-----	-----	Prop-A-Imp
6	SCS Runoff	19.64	6	804	311,044	---	-----	-----	Prop-A-Perv
7	Combine	24.05	6	798	367,533	5, 6	-----	-----	Prop-A
10	SCS Runoff	5.09	6	774	55,307	---	-----	-----	Exist-B-Imp
11	SCS Runoff	2.78	6	936	77,047	---	-----	-----	Exist-B-Perv
12	Combine	5.23	6	780	132,354	10, 11	-----	-----	Exist-B
14	SCS Runoff	0.26	6	774	2,836	---	-----	-----	Prop-B-Imp
15	SCS Runoff	1.11	6	906	29,993	---	-----	-----	Prop-B-Perv
17	SCS Runoff	1.36	6	774	14,796	---	-----	-----	Prop-B-Imp-FAN-Basin
18	SCS Runoff	3.12	6	870	80,065	---	-----	-----	Prop-B-Perv-FAN-Basin
19	Combine	3.49	6	846	94,860	17, 18	-----	-----	FAN Basin Inflow
20	Reservoir	1.00	6	1464	72,611	19	155.81	59,618	FAN Basin 1 Routing
21	SCS Runoff	0.44	6	774	4,727	---	-----	-----	Prop-B-Imp-ROCA-Basin
22	SCS Runoff	1.37	6	810	24,018	---	-----	-----	Prop-B-Perv-ROCA-Basin
23	Combine	1.72	6	798	28,745	21, 22	-----	-----	ROCA Basin Inflow
24	Reservoir	0.70	6	972	27,618	23	155.42	10,351	ROCA Basin Routing
25	Combine	1.15	6	894	32,830	14, 15,	-----	-----	Prop-B
26	Combine	2.53	6	948	133,058	20, 24, 25	-----	-----	Prop-B
29	SCS Runoff	3.87	6	768	38,622	---	-----	-----	Exist-C-Imp
30	SCS Runoff	23.82	6	792	348,921	---	-----	-----	Exist-C-Perv
31	Combine	27.03	6	786	387,543	29, 30	-----	-----	Exist-C

Hydrograph Summary Report

Hyd. No.	Hydrograph type (origin)	Peak flow (cfs)	Time interval (min)	Time to peak (min)	Volume (cuft)	Inflow hyd(s)	Maximum elevation (ft)	Maximum storage (cuft)	Hydrograph description
33	SCS Runoff	3.31	6	768	33,038	---	-----	-----	Prop-C-Imp
34	SCS Runoff	24.26	6	792	355,358	---	-----	-----	Prop-C-Perv
35	Combine	27.00	6	792	388,396	33, 34	-----	-----	Prop-C

Hydrograph Plot

Hydraflow Hydrographs by Intelisolve

Tuesday, Feb 11 2020, 10:32 AM

Hyd. No. 1

Exist-A-Imp

Hydrograph type = SCS Runoff
 Storm frequency = 50 yrs
 Drainage area = 2.64 ac
 Basin Slope = 0.0 %
 Tc method = USER
 Total precip. = 6.75 in
 Storm duration = 24 hrs

Peak discharge = 5.39 cfs
 Time interval = 6 min
 Curve number = 98
 Hydraulic length = 0 ft
 Time of conc. (Tc) = 91.29 min
 Distribution = Type III
 Shape factor = 484

Hydrograph Volume = 63,177 cuft

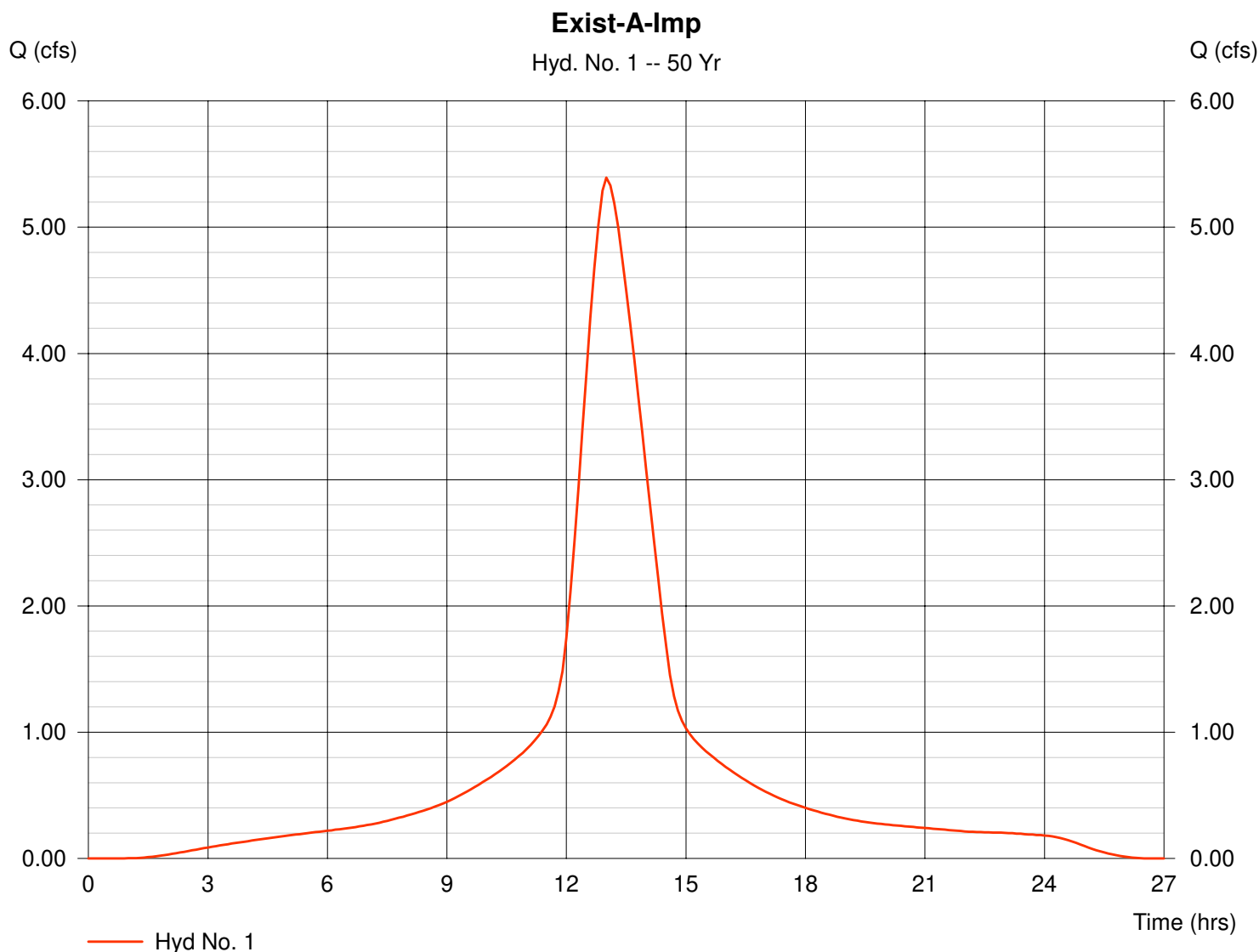

Hydrograph Plot

Hydraflow Hydrographs by Intelisolve

Tuesday, Feb 11 2020, 10:32 AM

Hyd. No. 2

Exist-A-Perv

Hydrograph type = SCS Runoff
Storm frequency = 50 yrs
Drainage area = 123.80 ac
Basin Slope = 0.0 %
Tc method = USER
Total precip. = 6.75 in
Storm duration = 24 hrs

Peak discharge = 17.36 cfs
Time interval = 6 min
Curve number = 39
Hydraulic length = 0 ft
Time of conc. (Tc) = 91.29 min
Distribution = Type III
Shape factor = 484

Hydrograph Volume = 308,103 cuft

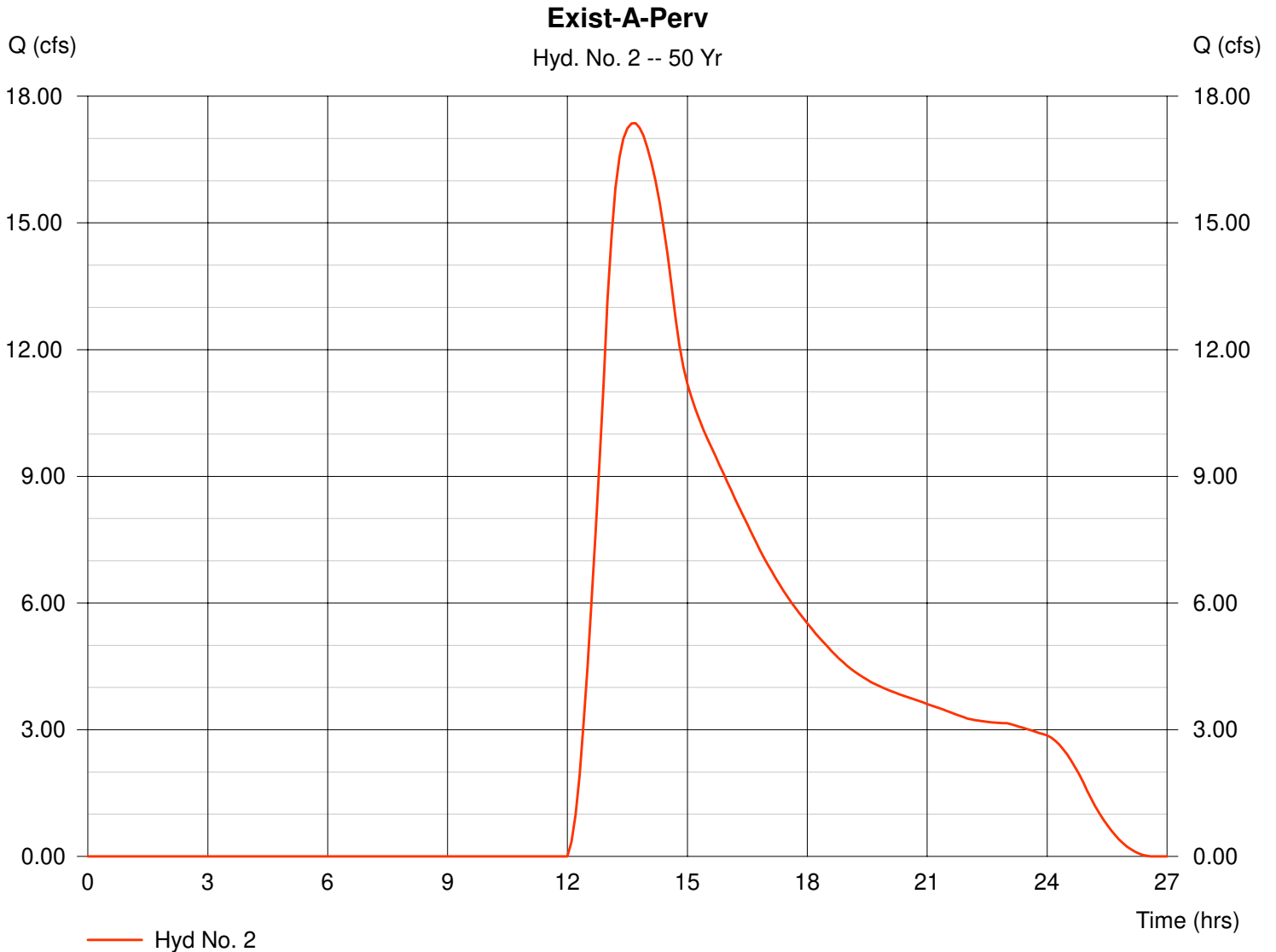

Hydrograph Plot

Hydraflow Hydrographs by Intelisolve

Tuesday, Feb 11 2020, 10:32 AM

Hyd. No. 3

Exist-A

Hydrograph type = Combine
Storm frequency = 50 yrs
Inflow hyds. = 1, 2

Peak discharge = 21.75 cfs
Time interval = 6 min

Hydrograph Volume = 371,280 cuft

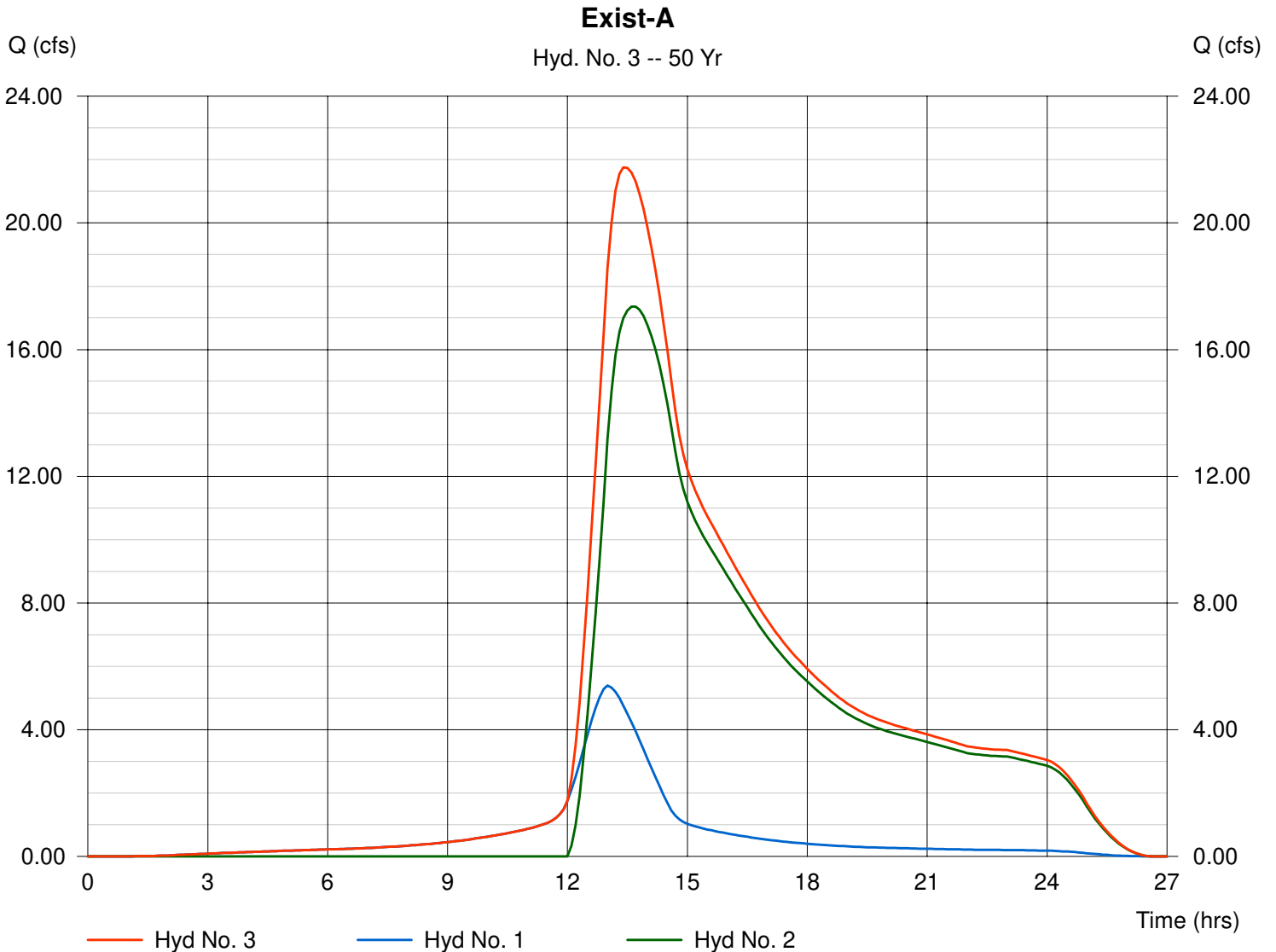

Hydrograph Plot

Hydraflow Hydrographs by Intelisolve

Tuesday, Feb 11 2020, 10:32 AM

Hyd. No. 5

Prop-A-Imp

Hydrograph type = SCS Runoff
Storm frequency = 50 yrs
Drainage area = 2.39 ac
Basin Slope = 0.0 %
Tc method = USER
Total precip. = 6.75 in
Storm duration = 24 hrs

Peak discharge = 5.20 cfs
Time interval = 6 min
Curve number = 98
Hydraulic length = 0 ft
Time of conc. (Tc) = 90.72 min
Distribution = Type III
Shape factor = 484

Hydrograph Volume = 56,489 cuft

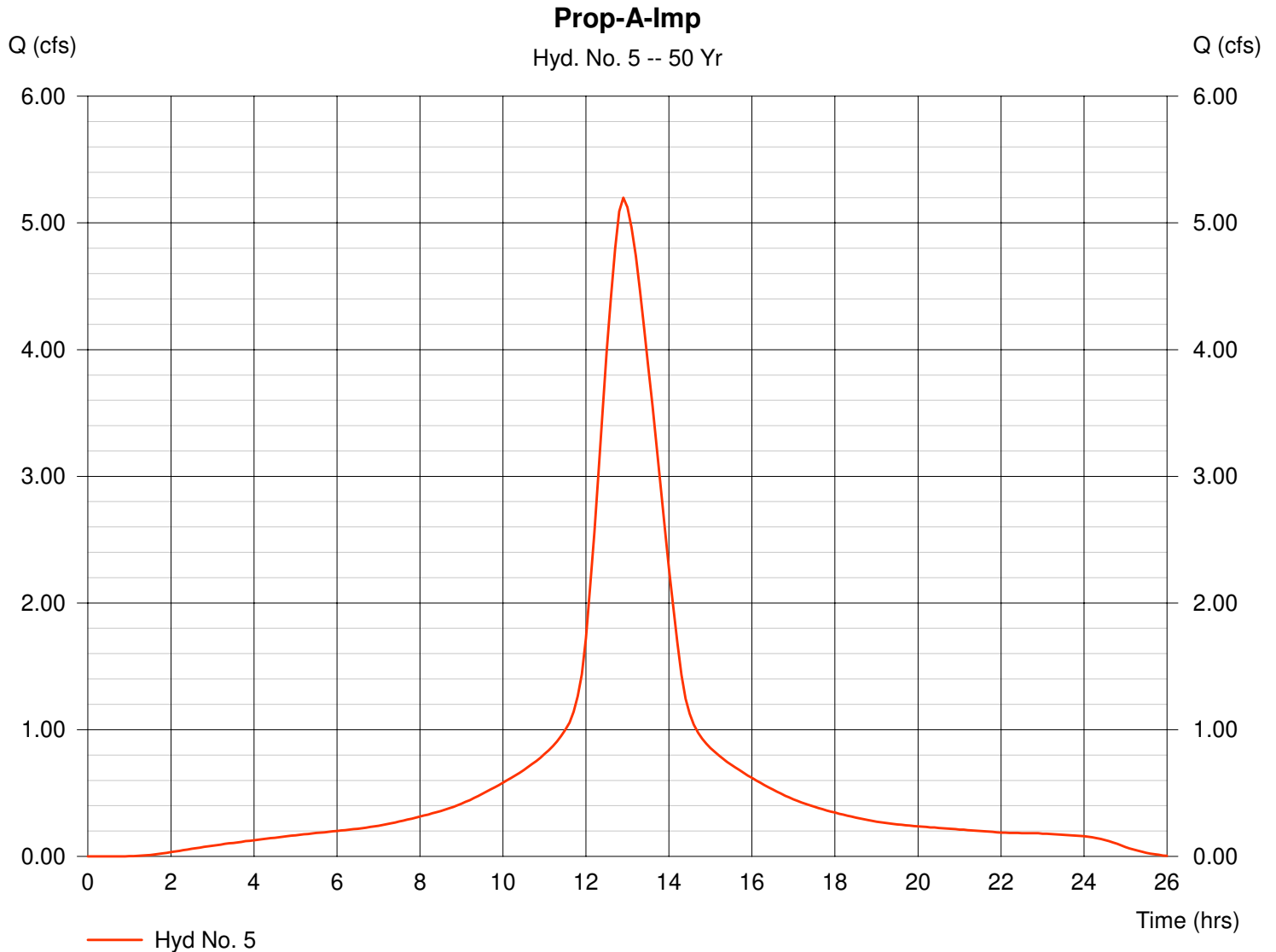

Hydrograph Plot

Hydraflow Hydrographs by Intelisolve

Tuesday, Feb 11 2020, 10:32 AM

Hyd. No. 6

Prop-A-Perv

Hydrograph type = SCS Runoff
 Storm frequency = 50 yrs
 Drainage area = 114.63 ac
 Basin Slope = 0.0 %
 Tc method = USER
 Total precip. = 6.75 in
 Storm duration = 24 hrs

Peak discharge = 19.64 cfs
 Time interval = 6 min
 Curve number = 40
 Hydraulic length = 0 ft
 Time of conc. (Tc) = 90.7 min
 Distribution = Type III
 Shape factor = 484

Hydrograph Volume = 311,044 cuft

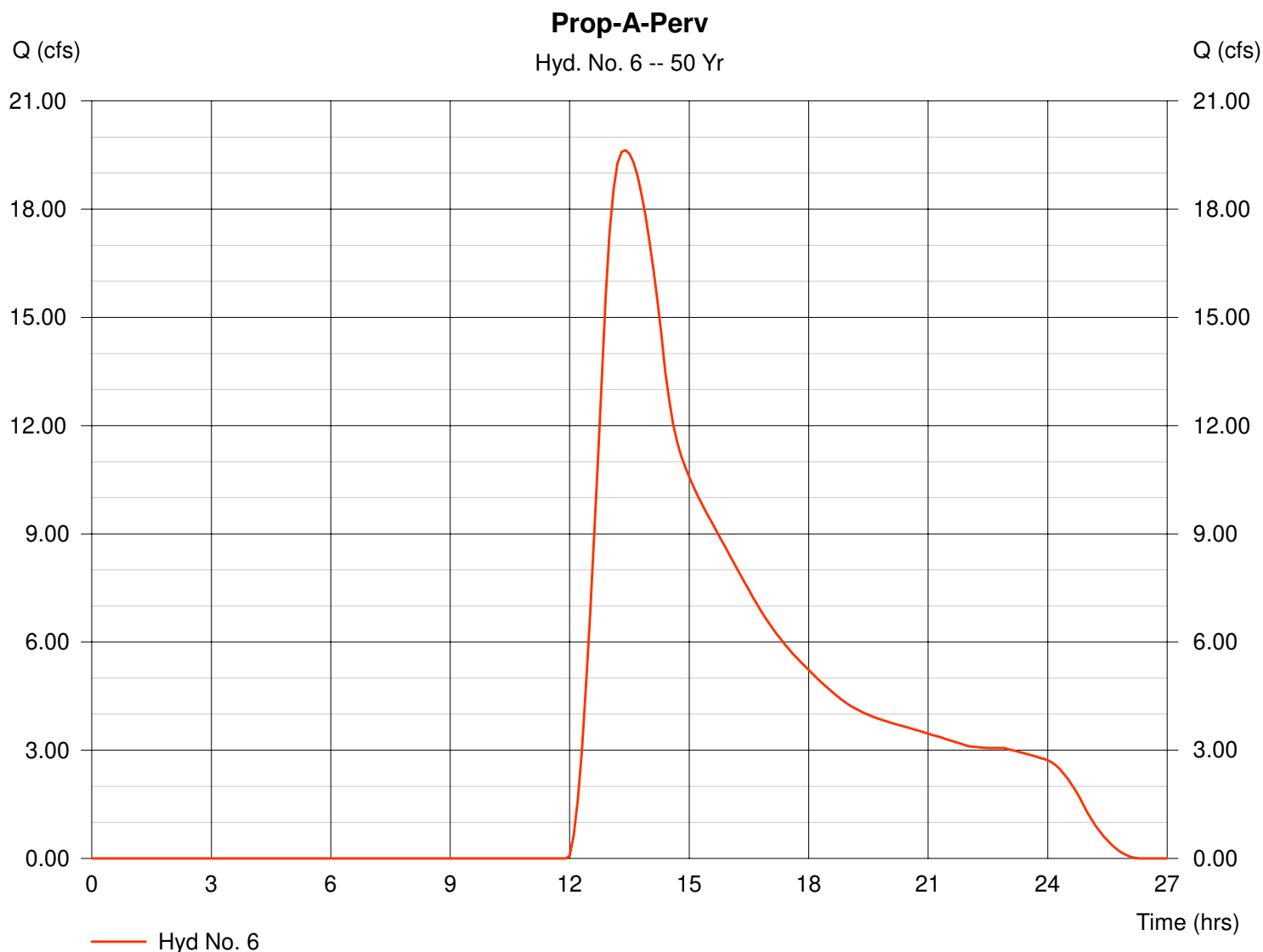

Hydrograph Plot

Hydraflow Hydrographs by Intelisolve

Tuesday, Feb 11 2020, 10:32 AM

Hyd. No. 7

Prop-A

Hydrograph type = Combine
Storm frequency = 50 yrs
Inflow hyds. = 5, 6

Peak discharge = 24.05 cfs
Time interval = 6 min

Hydrograph Volume = 367,533 cuft

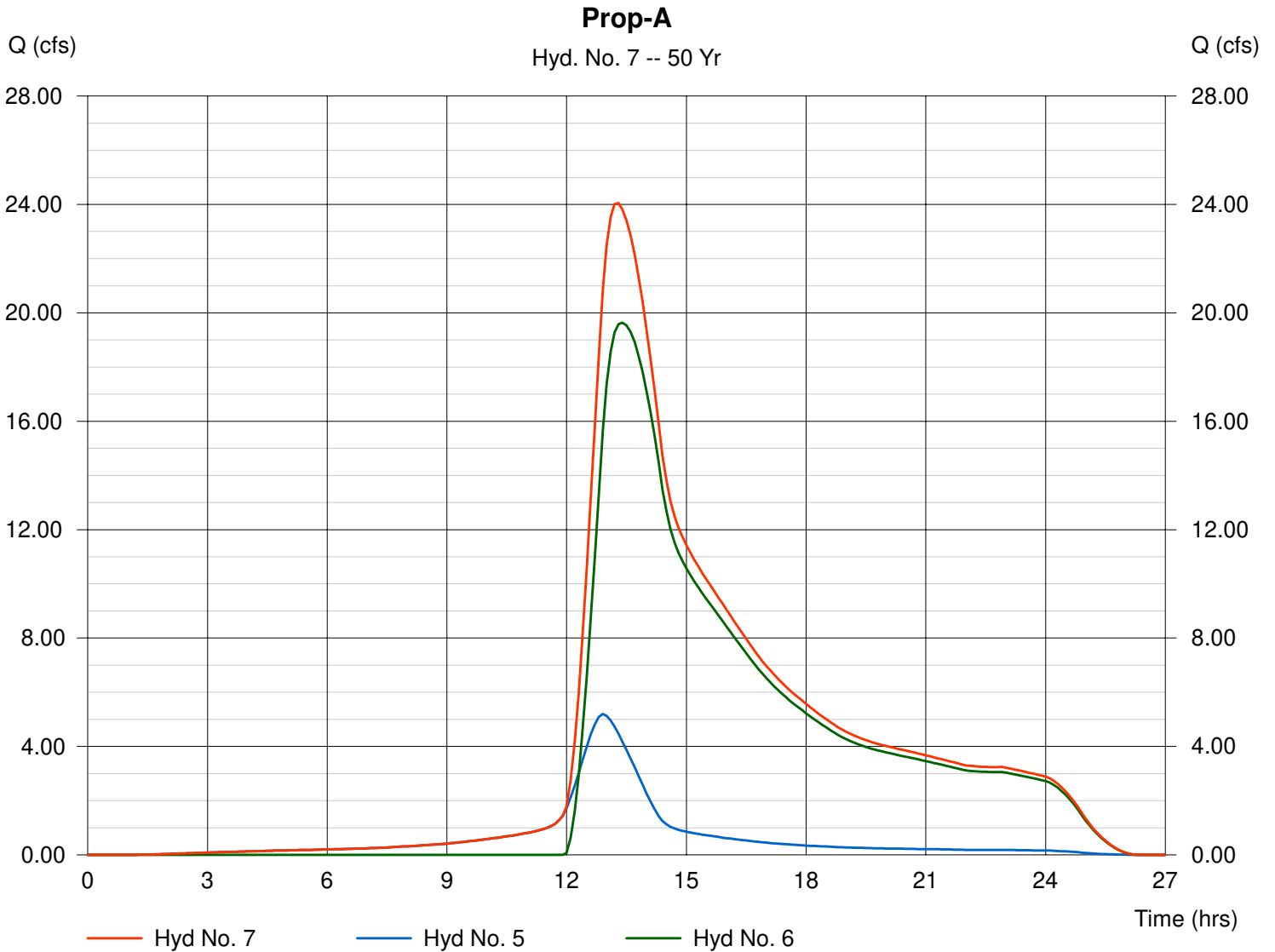

Hydrograph Plot

Hydraflow Hydrographs by Intelisolve

Tuesday, Feb 11 2020, 10:32 AM

Hyd. No. 10

Exist-B-Imp

Hydrograph type = SCS Runoff
Storm frequency = 50 yrs
Drainage area = 2.34 ac
Basin Slope = 0.0 %
Tc method = USER
Total precip. = 6.75 in
Storm duration = 24 hrs

Peak discharge = 5.09 cfs
Time interval = 6 min
Curve number = 98
Hydraulic length = 0 ft
Time of conc. (Tc) = 87.72 min
Distribution = Type III
Shape factor = 484

Hydrograph Volume = 55,307 cuft

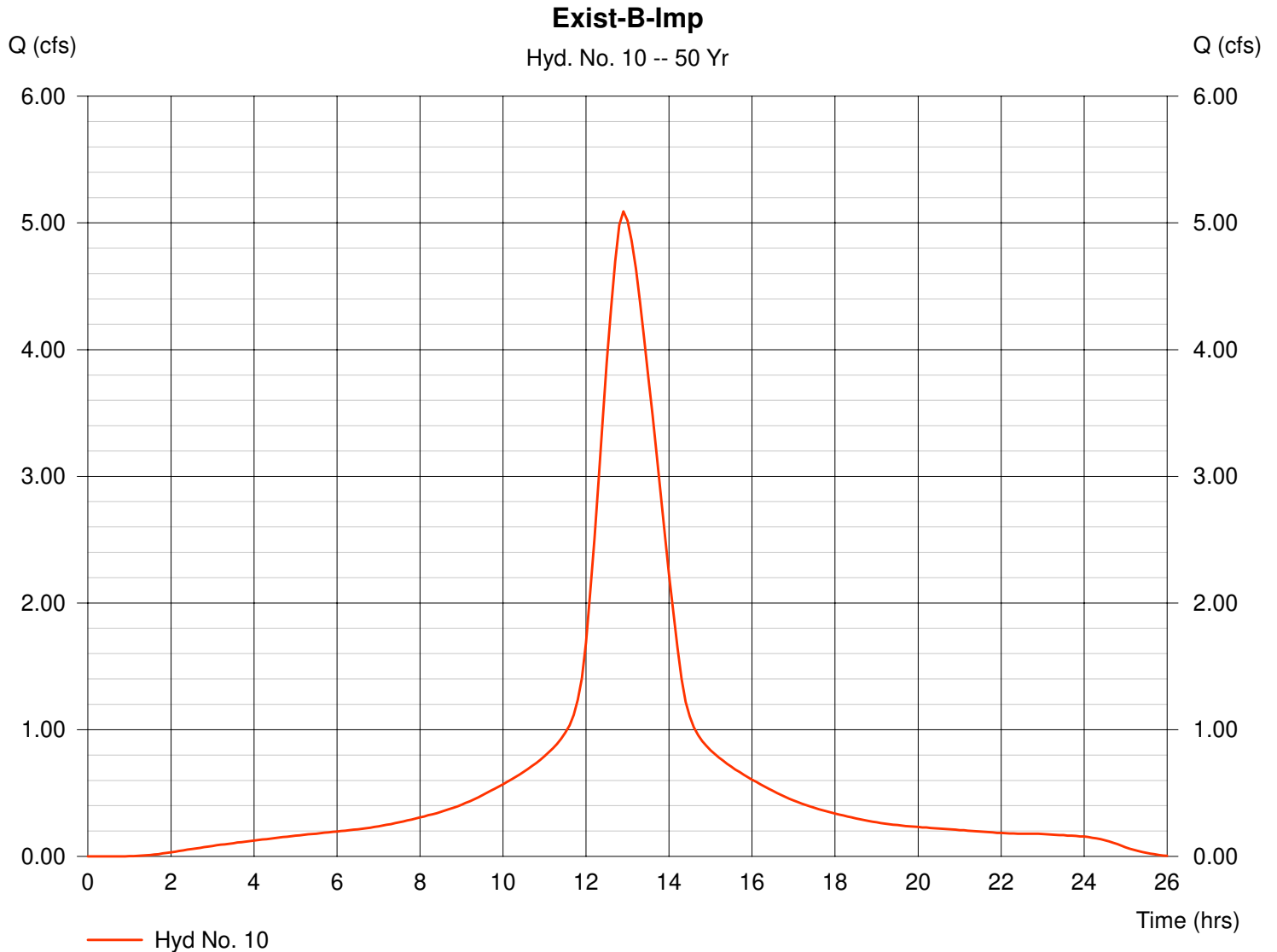

Hydrograph Plot

Hydraflow Hydrographs by Intelisolve

Tuesday, Feb 11 2020, 10:32 AM

Hyd. No. 11

Exist-B-Perv

Hydrograph type = SCS Runoff
Storm frequency = 50 yrs
Drainage area = 124.34 ac
Basin Slope = 0.0 %
Tc method = USER
Total precip. = 6.75 in
Storm duration = 24 hrs

Peak discharge = 2.78 cfs
Time interval = 6 min
Curve number = 30
Hydraulic length = 0 ft
Time of conc. (Tc) = 87.7 min
Distribution = Type III
Shape factor = 484

Hydrograph Volume = 77,047 cuft

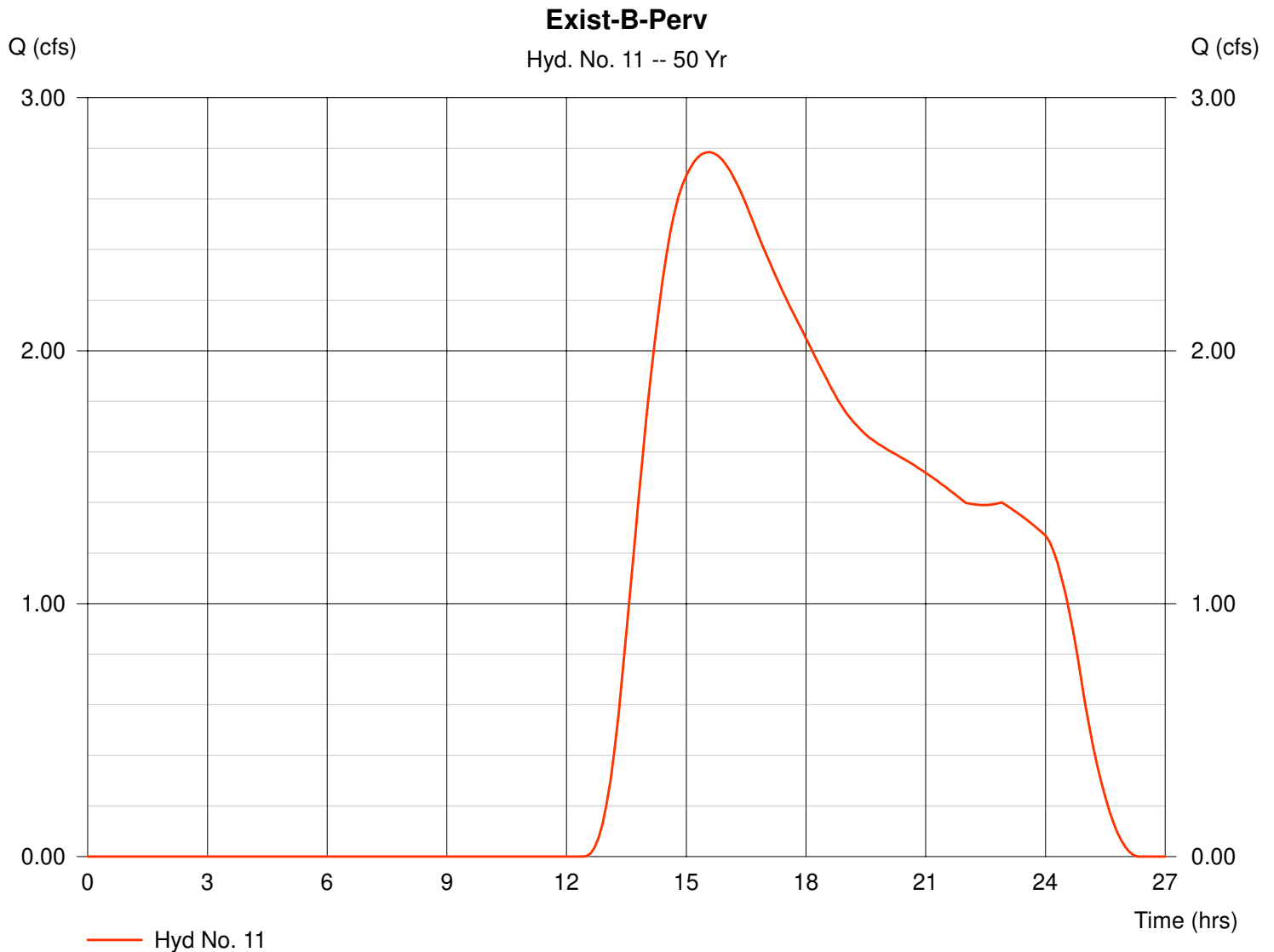

Hydrograph Plot

Hydraflow Hydrographs by Intelisolve

Tuesday, Feb 11 2020, 10:32 AM

Hyd. No. 12

Exist-B

Hydrograph type = Combine
Storm frequency = 50 yrs
Inflow hyds. = 10, 11

Peak discharge = 5.23 cfs
Time interval = 6 min

Hydrograph Volume = 132,354 cuft

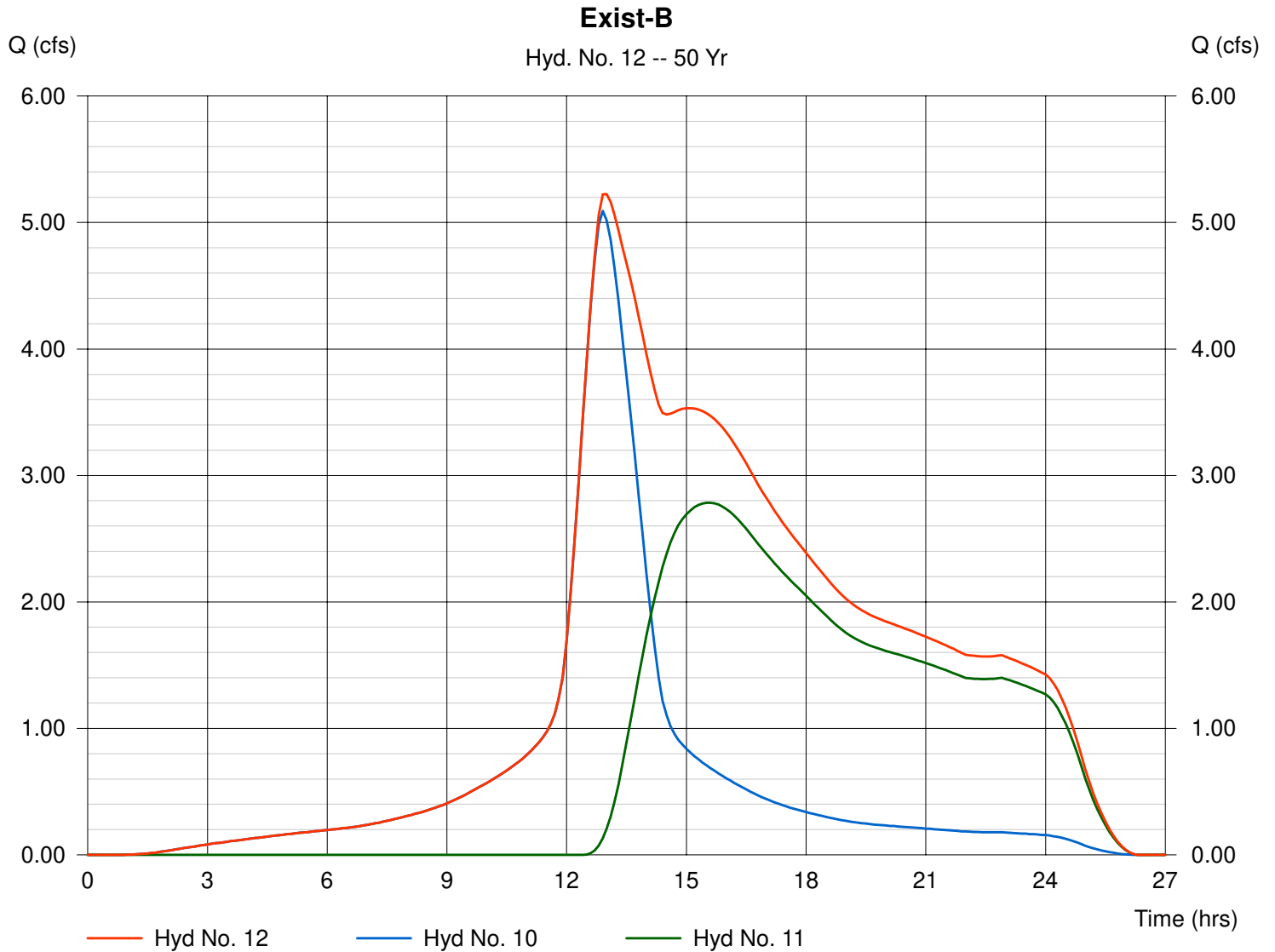

Hydrograph Plot

Hydraflow Hydrographs by Intelisolve

Tuesday, Feb 11 2020, 10:32 AM

Hyd. No. 14

Prop-B-Imp

Hydrograph type = SCS Runoff
 Storm frequency = 50 yrs
 Drainage area = 0.12 ac
 Basin Slope = 0.0 %
 Tc method = USER
 Total precip. = 6.75 in
 Storm duration = 24 hrs

Peak discharge = 0.26 cfs
 Time interval = 6 min
 Curve number = 98
 Hydraulic length = 0 ft
 Time of conc. (Tc) = 82.7 min
 Distribution = Type III
 Shape factor = 484

Hydrograph Volume = 2,836 cuft

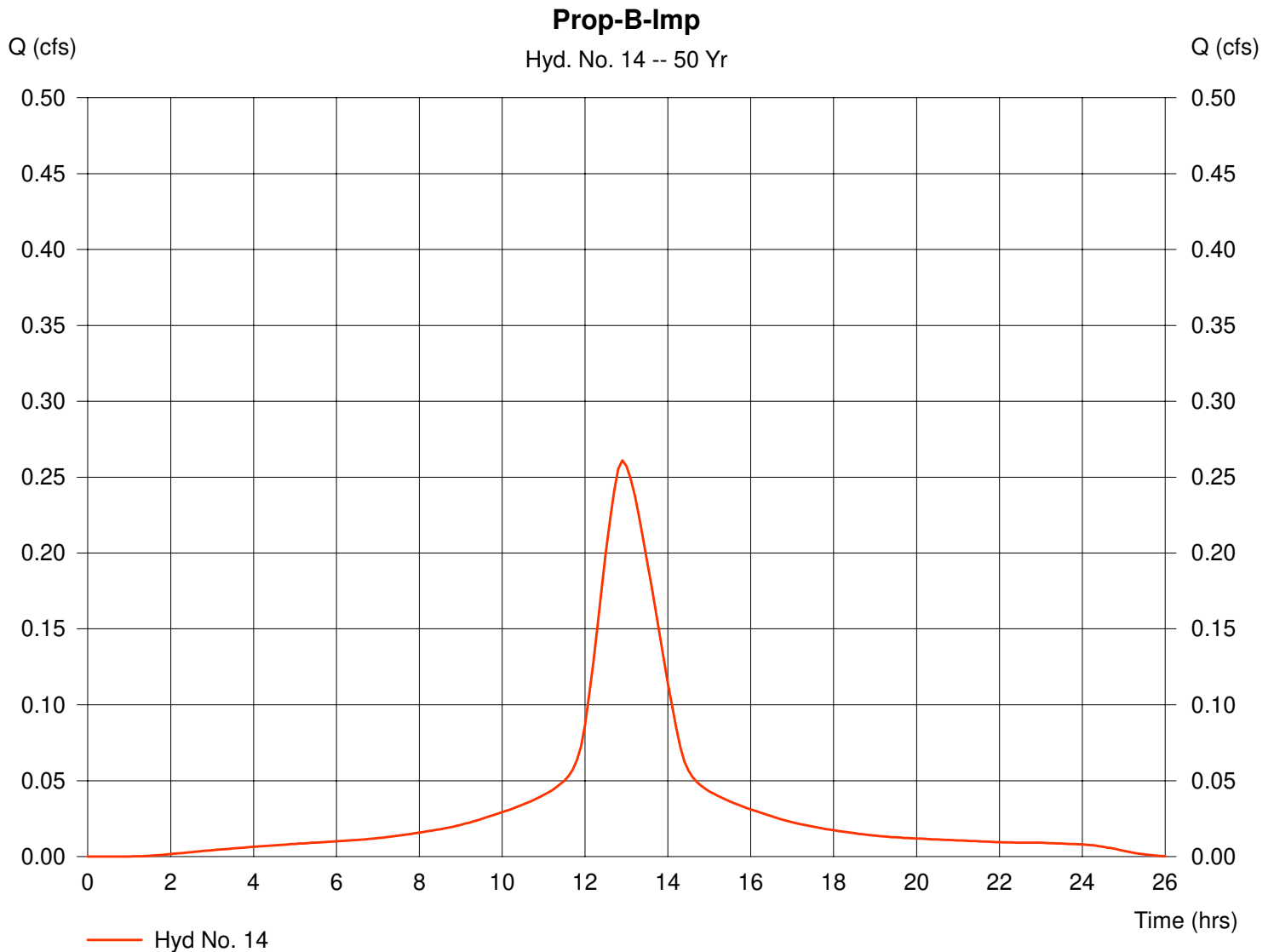

Hydrograph Plot

Hydraflow Hydrographs by Intelisolve

Tuesday, Feb 11 2020, 10:32 AM

Hyd. No. 15

Prop-B-Perv

Hydrograph type = SCS Runoff
Storm frequency = 50 yrs
Drainage area = 38.41 ac
Basin Slope = 0.0 %
Tc method = USER
Total precip. = 6.75 in
Storm duration = 24 hrs

Peak discharge = 1.11 cfs
Time interval = 6 min
Curve number = 31
Hydraulic length = 0 ft
Time of conc. (Tc) = 82.7 min
Distribution = Type III
Shape factor = 484

Hydrograph Volume = 29,993 cuft

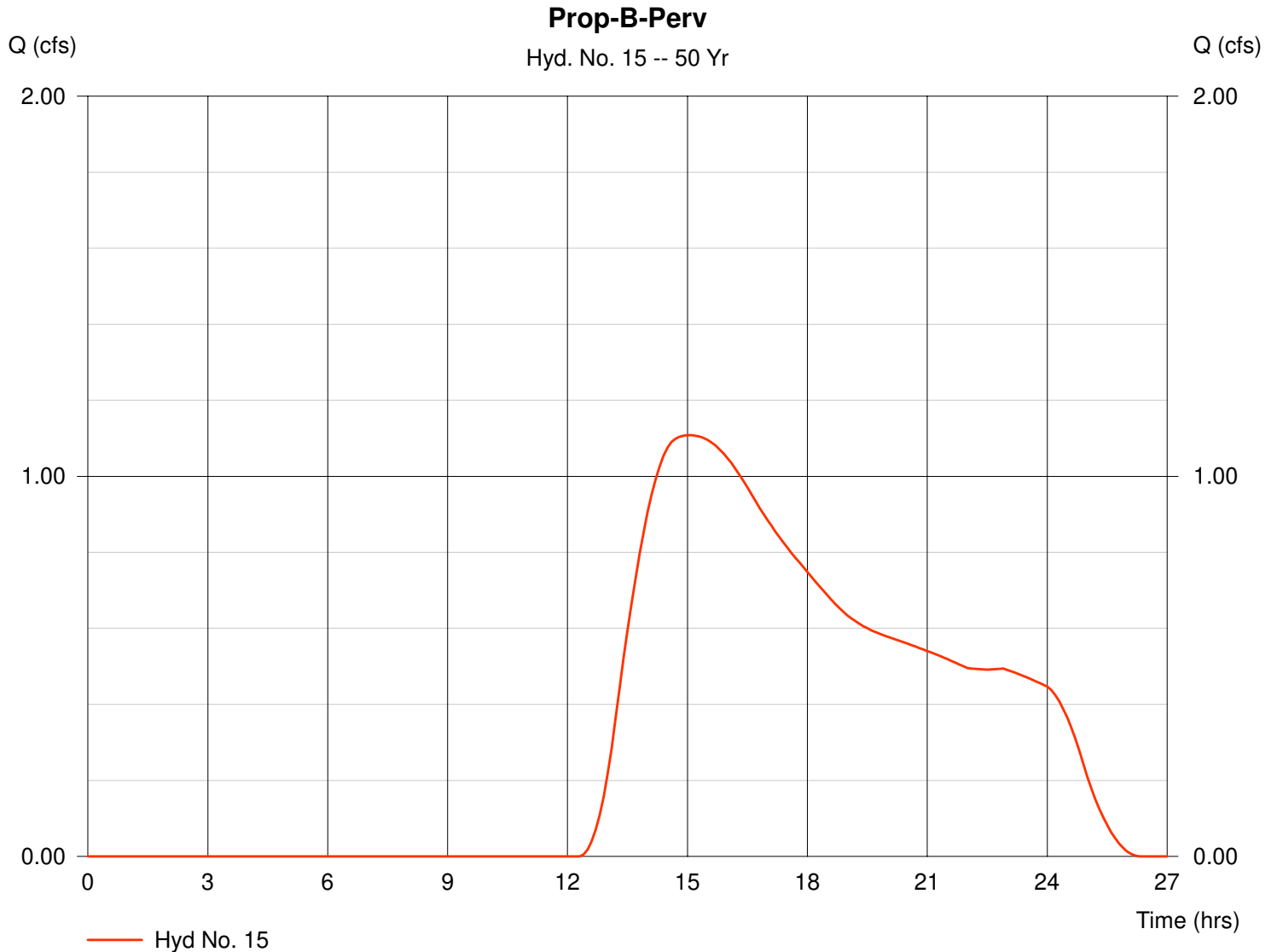

Hydrograph Plot

Hydraflow Hydrographs by Intelisolve

Tuesday, Feb 11 2020, 10:32 AM

Hyd. No. 17

Prop-B-Imp-FAN-Basin

Hydrograph type = SCS Runoff
Storm frequency = 50 yrs
Drainage area = 0.63 ac
Basin Slope = 0.0 %
Tc method = USER
Total precip. = 6.75 in
Storm duration = 24 hrs

Peak discharge = 1.36 cfs
Time interval = 6 min
Curve number = 98
Hydraulic length = 0 ft
Time of conc. (Tc) = 82.7 min
Distribution = Type III
Shape factor = 484

Hydrograph Volume = 14,796 cuft

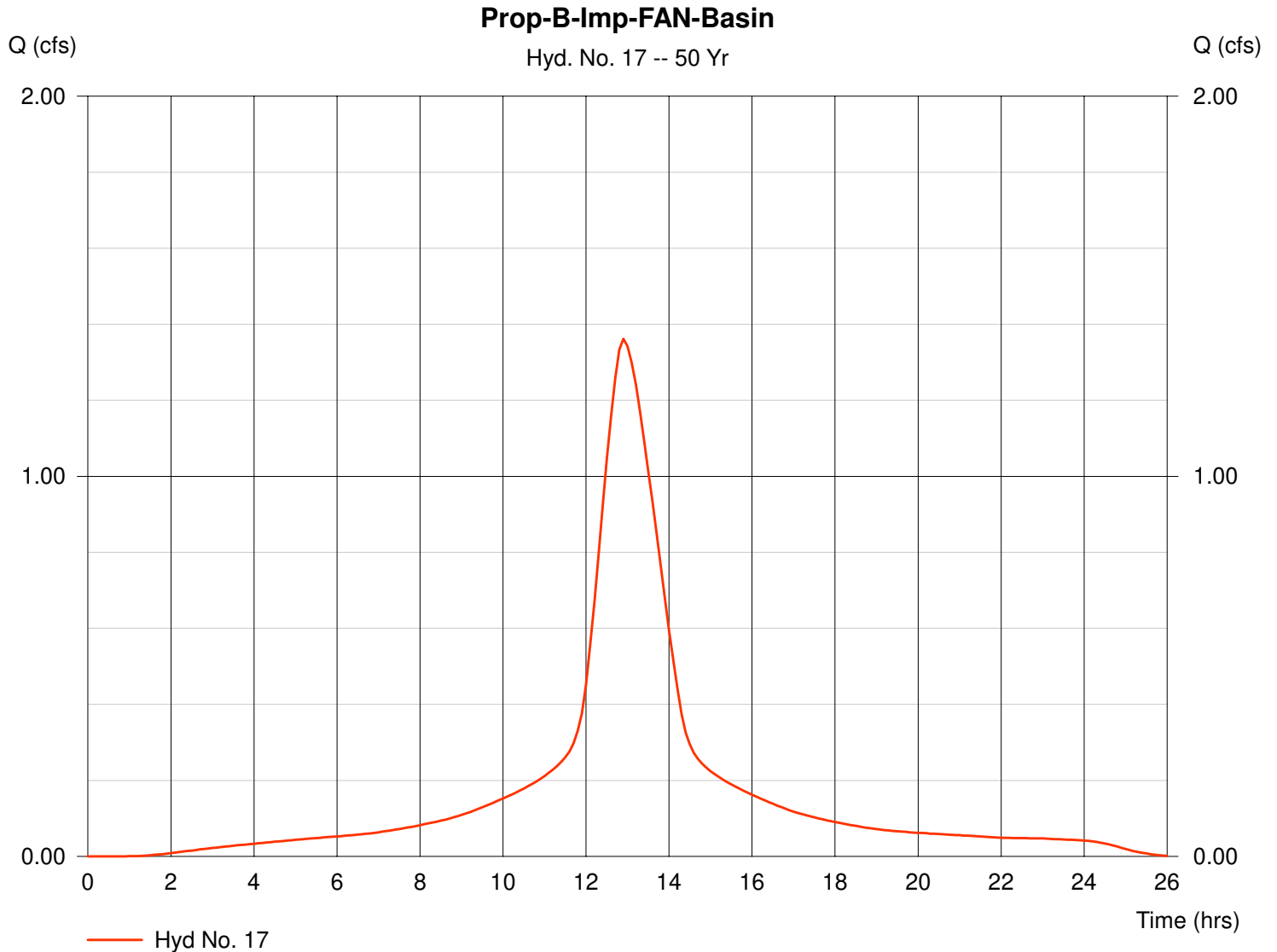

Hydrograph Plot

Hydraflow Hydrographs by Intelisolve

Tuesday, Feb 11 2020, 10:32 AM

Hyd. No. 18

Prop-B-Perv-FAN-Basin

Hydrograph type = SCS Runoff
Storm frequency = 50 yrs
Drainage area = 83.82 ac
Basin Slope = 0.0 %
Tc method = USER
Total precip. = 6.75 in
Storm duration = 24 hrs

Peak discharge = 3.12 cfs
Time interval = 6 min
Curve number = 32
Hydraulic length = 0 ft
Time of conc. (Tc) = 82.7 min
Distribution = Type III
Shape factor = 484

Hydrograph Volume = 80,065 cuft

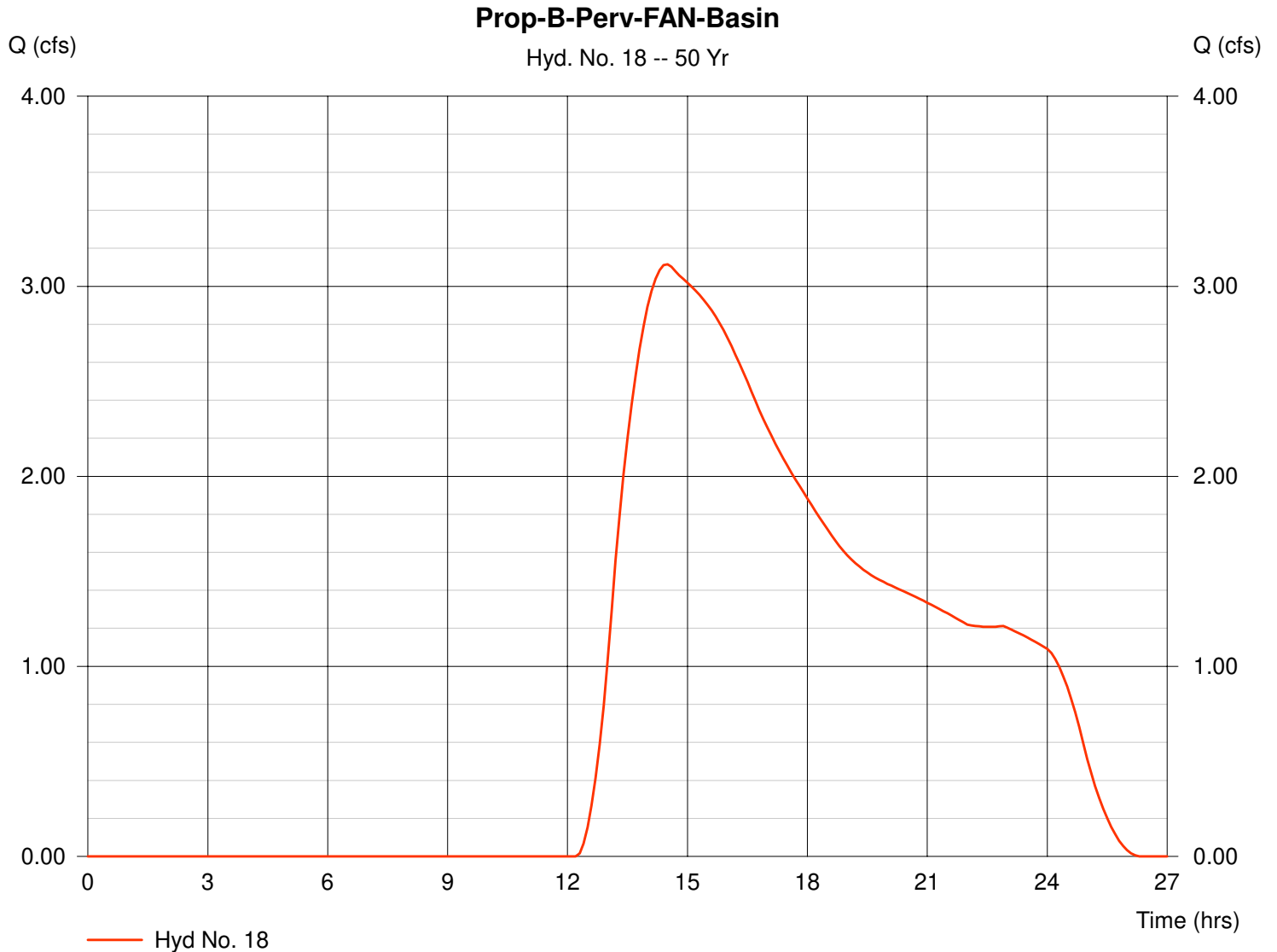

Hydrograph Plot

Hydraflow Hydrographs by Intelisolve

Tuesday, Feb 11 2020, 10:32 AM

Hyd. No. 19

FAN Basin Inflow

Hydrograph type = Combine
Storm frequency = 50 yrs
Inflow hyds. = 17, 18

Peak discharge = 3.49 cfs
Time interval = 6 min

Hydrograph Volume = 94,860 cuft

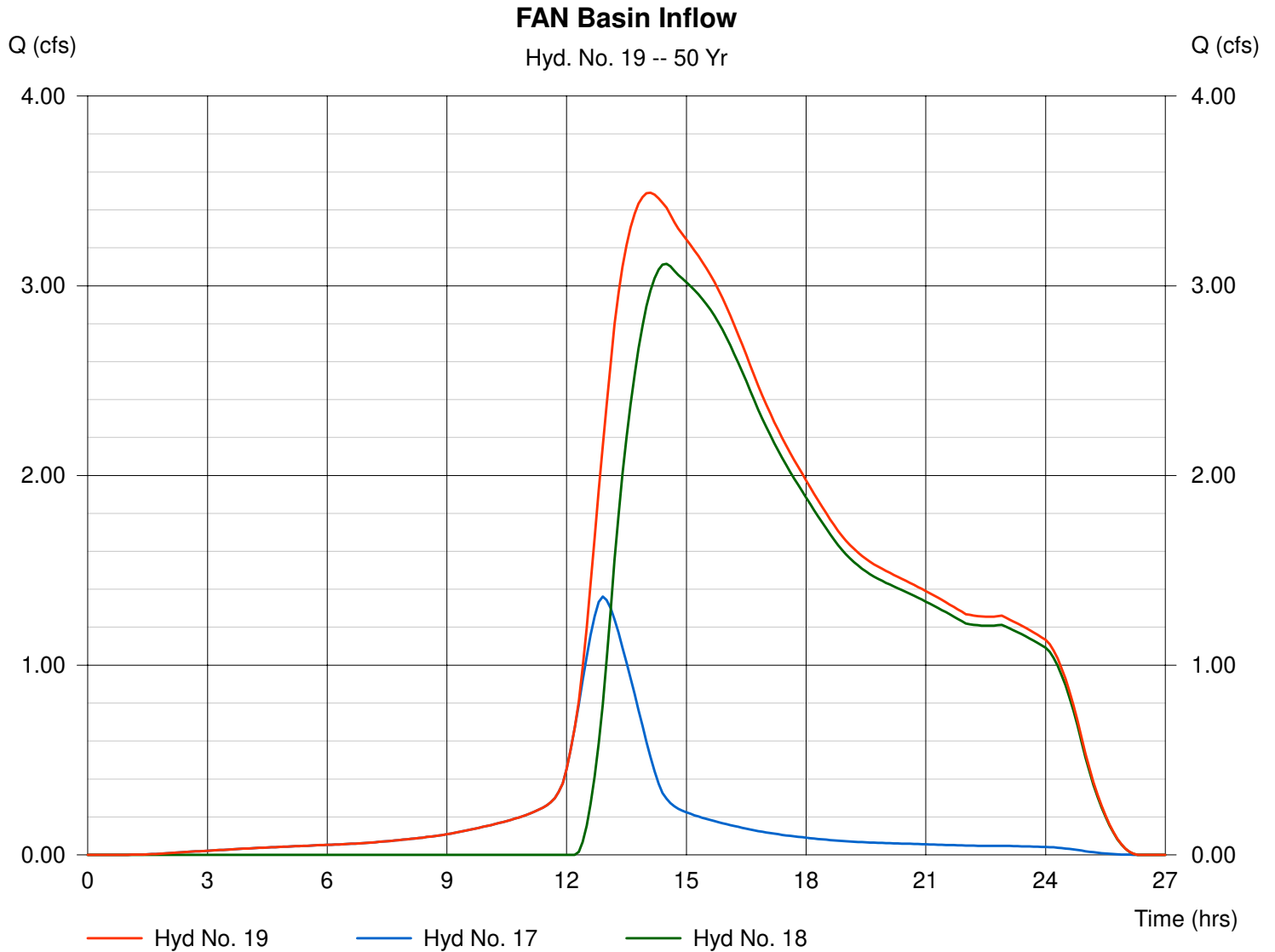

Hydrograph Plot

Hydraflow Hydrographs by Intelisolve

Tuesday, Feb 11 2020, 10:32 AM

Hyd. No. 20

FAN Basin 1 Routing

Hydrograph type = Reservoir
Storm frequency = 50 yrs
Inflow hyd. No. = 19
Reservoir name = FAN Basin

Peak discharge = 1.00 cfs
Time interval = 6 min
Max. Elevation = 155.81 ft
Max. Storage = 59,618 cuft

Storage Indication method used.

Hydrograph Volume = 72,611 cuft

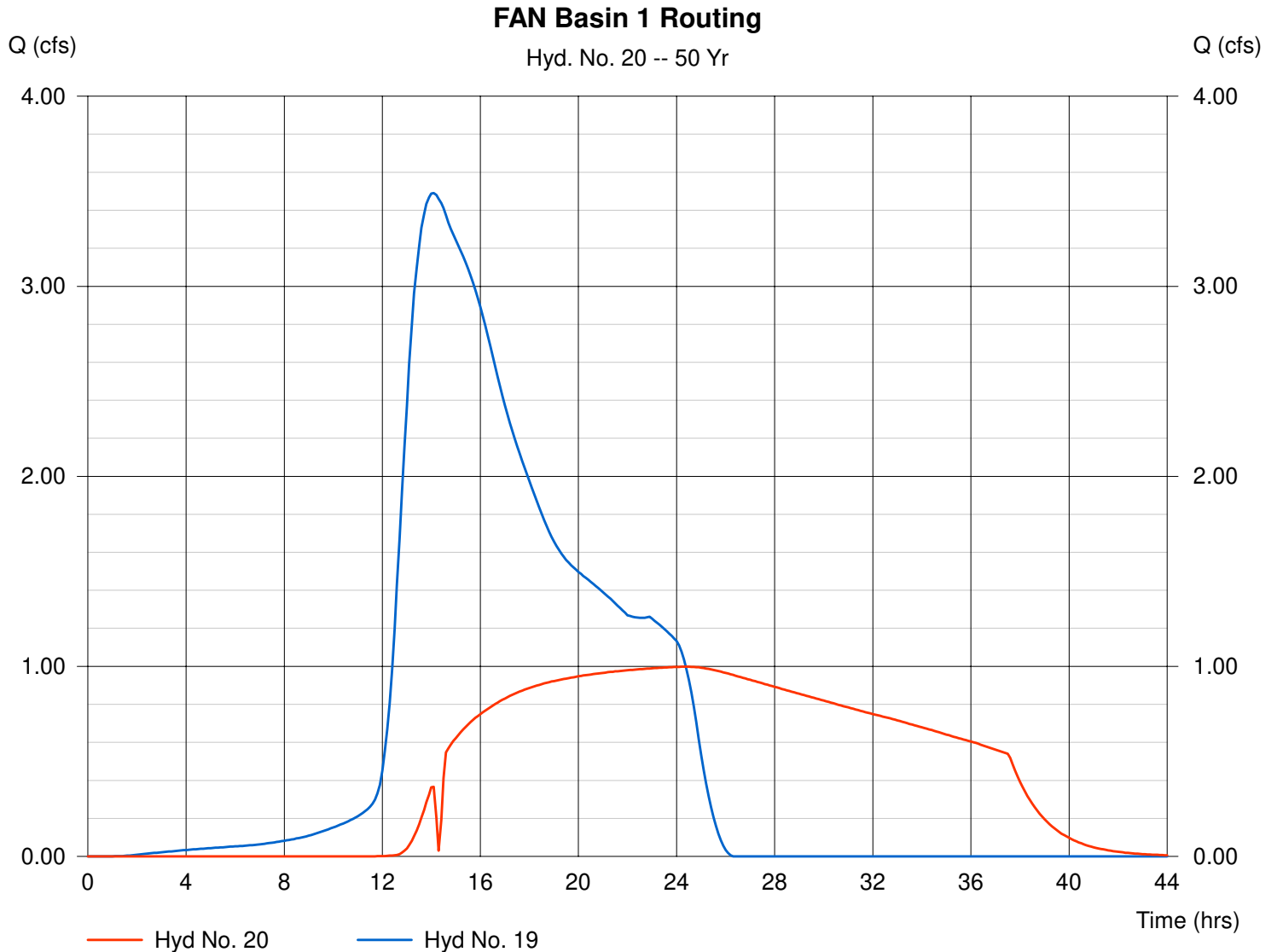

Pond Report

Hydraflow Hydrographs by Intelisolve

Tuesday, Feb 11 2020, 10:32 AM

Pond No. 1 - FAN Basin

Pond Data

Pond storage is based on known contour areas. Average end area method used.

Stage / Storage Table

Stage (ft)	Elevation (ft)	Contour area (sqft)	Incr. Storage (cuft)	Total storage (cuft)
0.00	154.25	36,091	0	0
0.75	155.00	38,058	27,806	27,806
1.75	156.00	40,796	39,427	67,233
2.75	157.00	43,656	42,226	109,459

Culvert / Orifice Structures

	[A]	[B]	[C]	[D]
Rise (in)	= 18.00	6.00	0.00	0.00
Span (in)	= 18.00	6.00	0.00	0.00
No. Barrels	= 1	1	0	0
Invert El. (ft)	= 154.25	154.35	0.00	0.00
Length (ft)	= 38.00	0.00	0.00	0.00
Slope (%)	= 3.30	0.00	0.00	0.00
N-Value	= .013	.013	.013	.000
Orif. Coeff.	= 0.60	0.60	0.60	0.00
Multi-Stage	= n/a	Yes	No	No

Weir Structures

	[A]	[B]	[C]	[D]
Crest Len (ft)	= 16.00	2.00	0.00	0.00
Crest El. (ft)	= 156.50	156.00	0.00	0.00
Weir Coeff.	= 3.33	3.33	3.33	0.00
Weir Type	= Riser	Rect	---	---
Multi-Stage	= Yes	Yes	No	No

Exfiltration = 0.000 in/hr (Contour) Tailwater Elev. = 0.00 ft

Note: Culvert/Orifice outflows have been analyzed under inlet and outlet control.

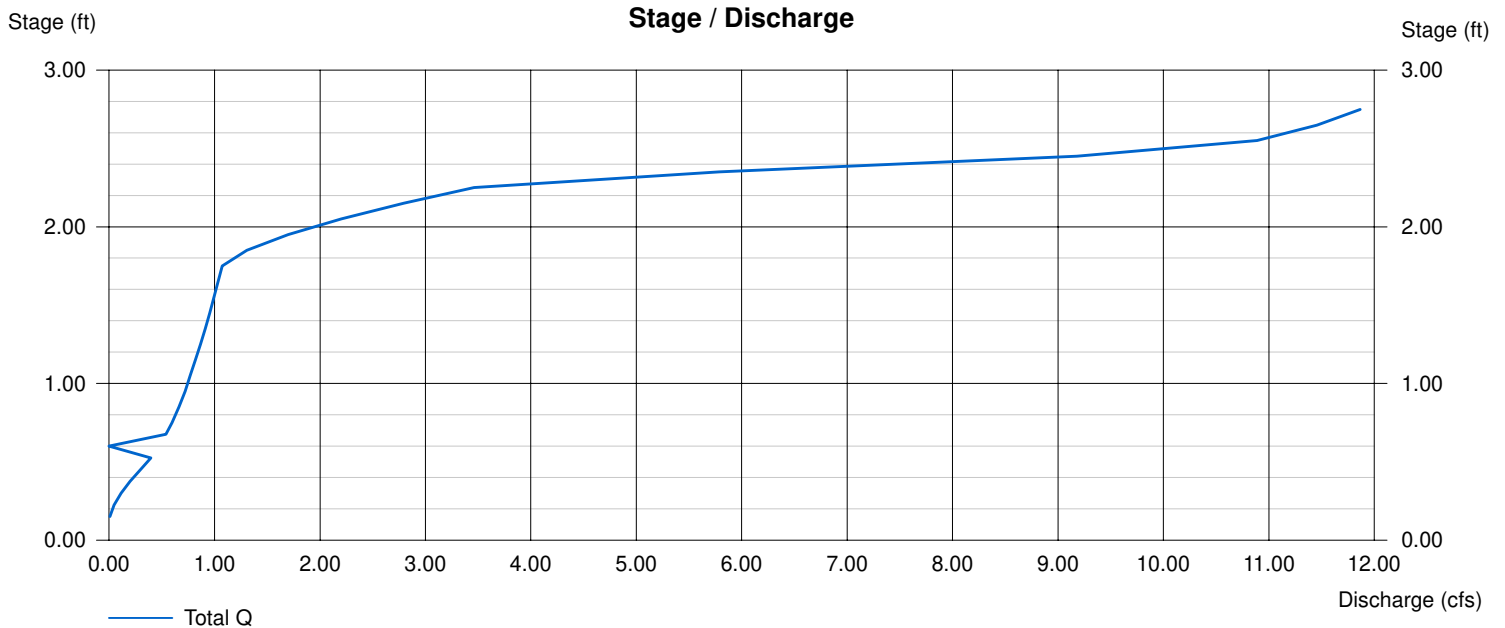

Hydrograph Plot

Hydraflow Hydrographs by Intelisolve

Tuesday, Feb 11 2020, 10:32 AM

Hyd. No. 21

Prop-B-Imp-ROCA-Basin

Hydrograph type = SCS Runoff
Storm frequency = 50 yrs
Drainage area = 0.20 ac
Basin Slope = 0.0 %
Tc method = USER
Total precip. = 6.75 in
Storm duration = 24 hrs

Peak discharge = 0.44 cfs
Time interval = 6 min
Curve number = 98
Hydraulic length = 0 ft
Time of conc. (Tc) = 82.7 min
Distribution = Type III
Shape factor = 484

Hydrograph Volume = 4,727 cuft

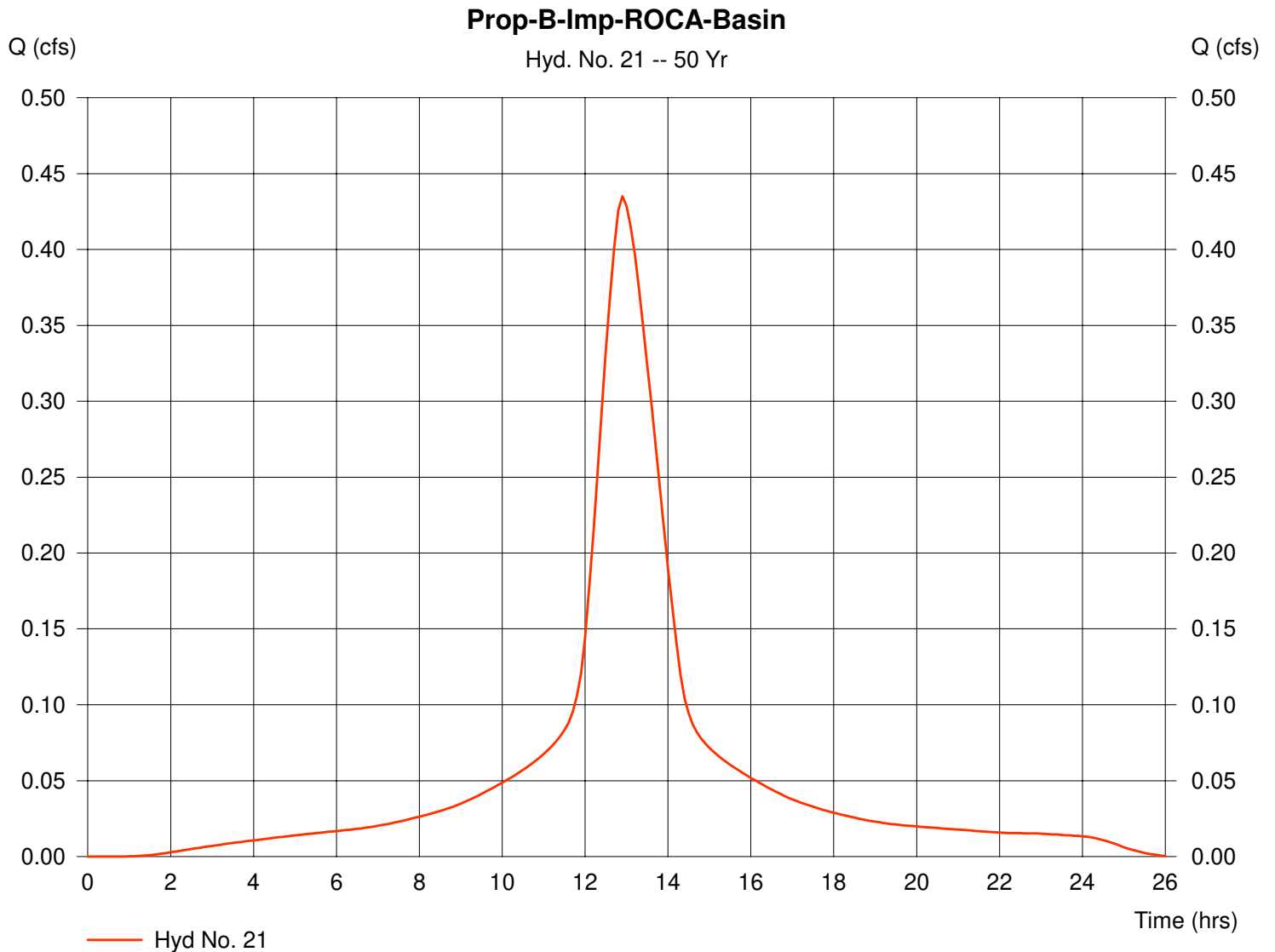

Hydrograph Plot

Hydraflow Hydrographs by Intelisolve

Tuesday, Feb 11 2020, 10:32 AM

Hyd. No. 22

Prop-B-Perv-ROCA-Basin

Hydrograph type = SCS Runoff
Storm frequency = 50 yrs
Drainage area = 10.79 ac
Basin Slope = 0.0 %
Tc method = USER
Total precip. = 6.75 in
Storm duration = 24 hrs

Peak discharge = 1.37 cfs
Time interval = 6 min
Curve number = 38
Hydraulic length = 0 ft
Time of conc. (Tc) = 82.7 min
Distribution = Type III
Shape factor = 484

Hydrograph Volume = 24,018 cuft

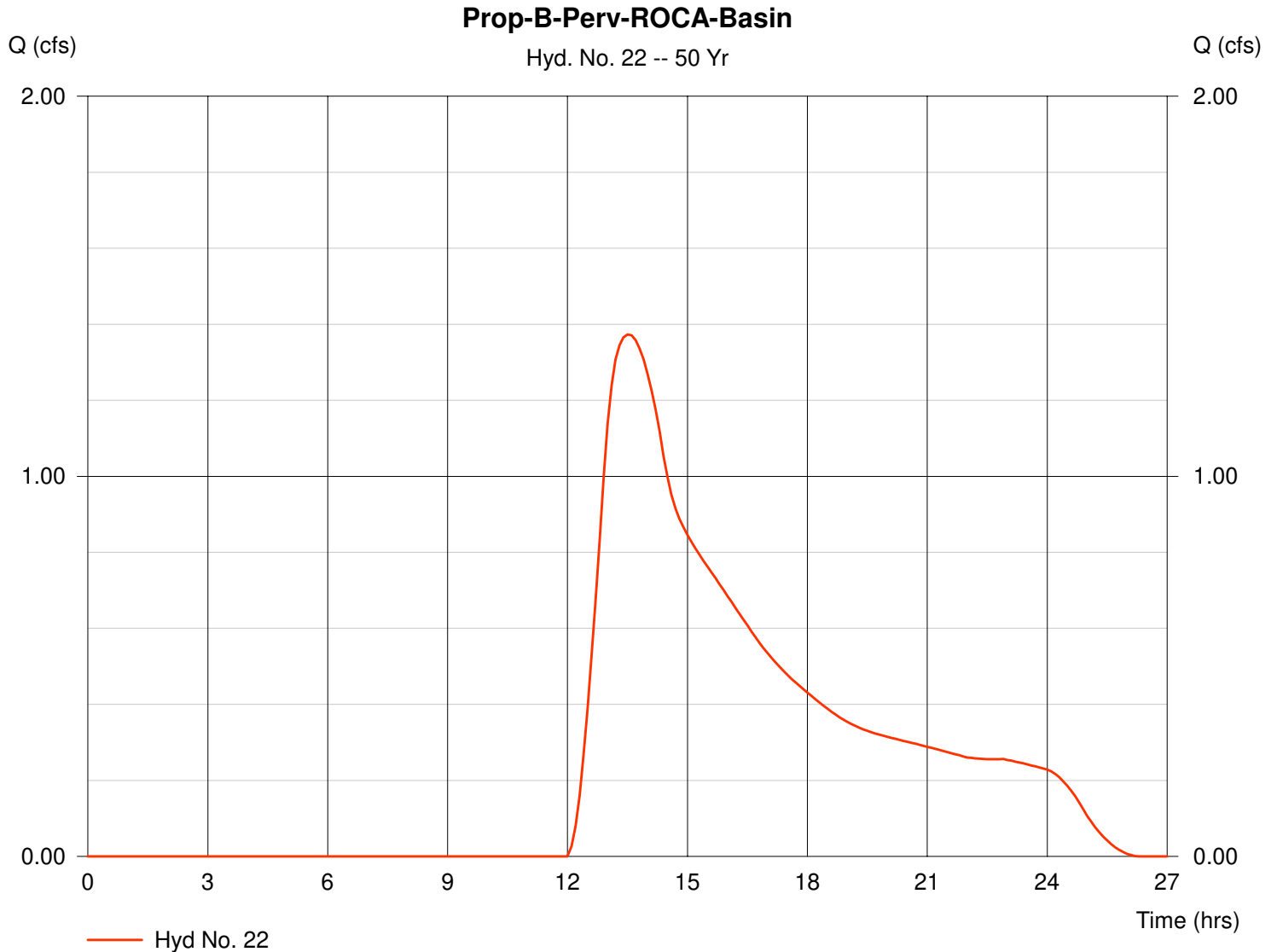

Hydrograph Plot

Hydraflow Hydrographs by Intelisolve

Tuesday, Feb 11 2020, 10:32 AM

Hyd. No. 23

ROCA Basin Inflow

Hydrograph type = Combine
Storm frequency = 50 yrs
Inflow hyds. = 21, 22

Peak discharge = 1.72 cfs
Time interval = 6 min

Hydrograph Volume = 28,745 cuft

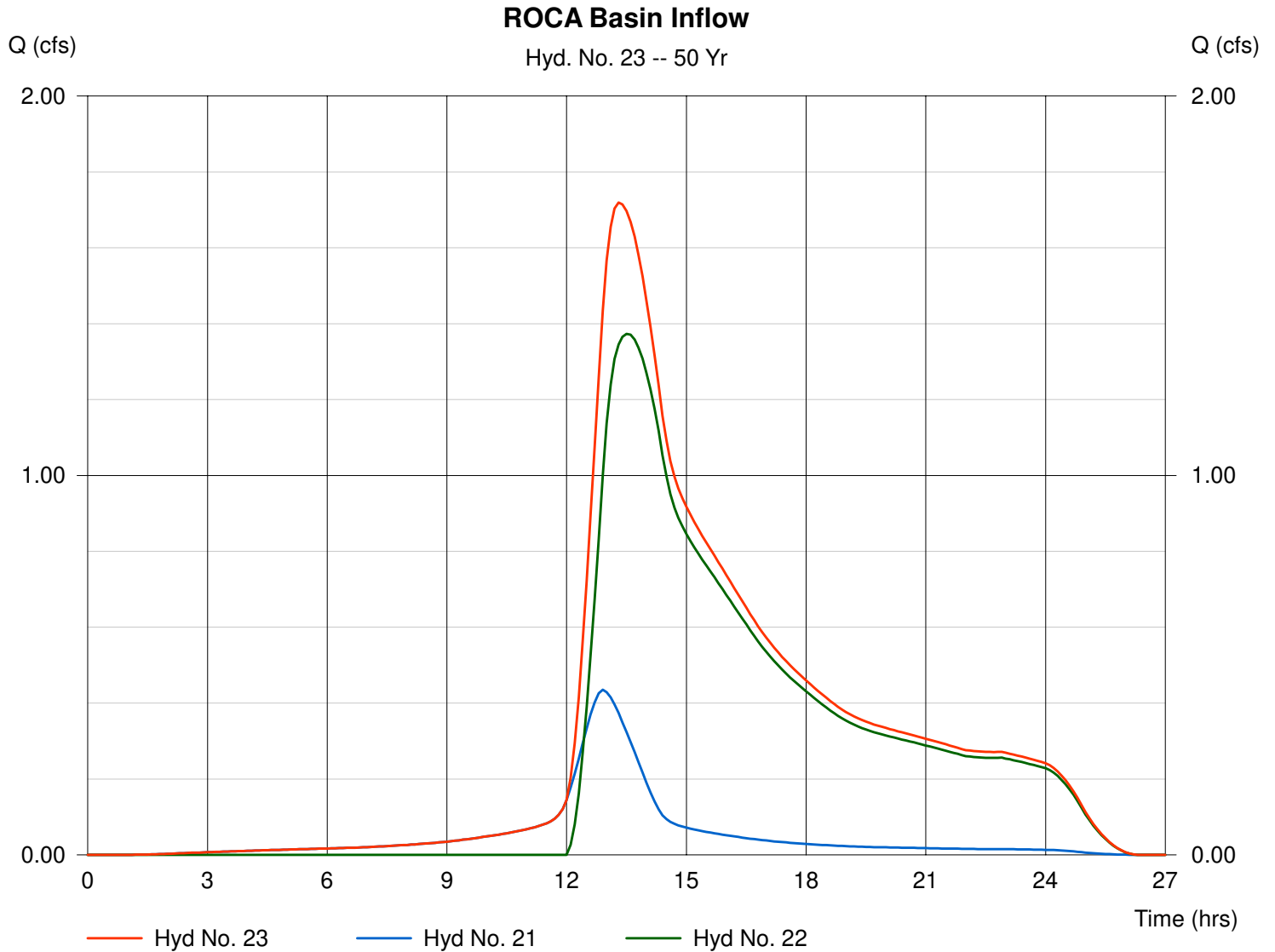

Hydrograph Plot

Hydraflow Hydrographs by Intelisolve

Tuesday, Feb 11 2020, 10:32 AM

Hyd. No. 24

ROCA Basin Routing

Hydrograph type = Reservoir
 Storm frequency = 50 yrs
 Inflow hyd. No. = 23
 Reservoir name = ROCA Basin

Peak discharge = 0.70 cfs
 Time interval = 6 min
 Max. Elevation = 155.42 ft
 Max. Storage = 10,351 cuft

Storage Indication method used.

Hydrograph Volume = 27,618 cuft

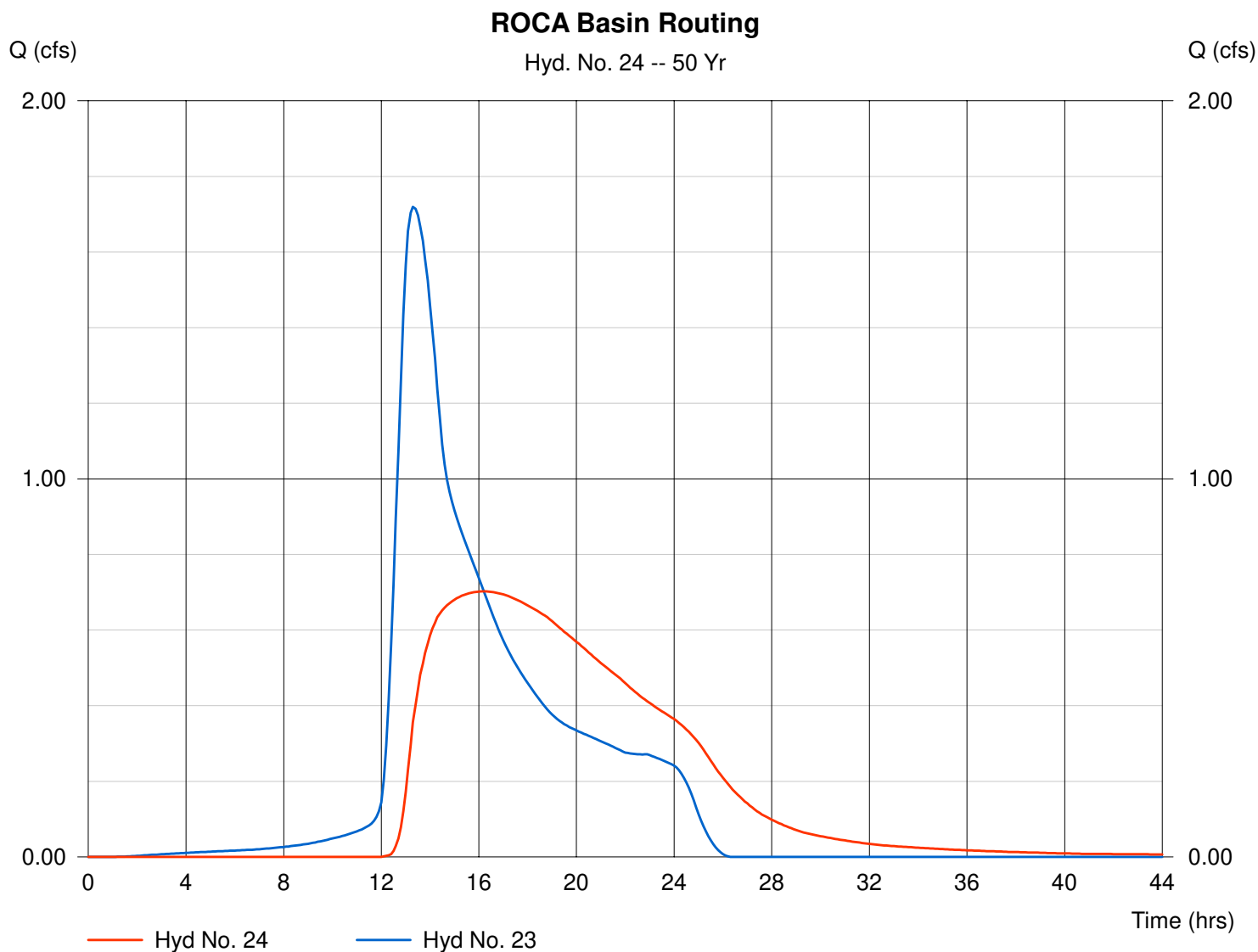

Pond Report

Hydraflow Hydrographs by Intelisolve

Tuesday, Feb 11 2020, 10:32 AM

Pond No. 2 - ROCA Basin

Pond Data

Pond storage is based on known contour areas. Average end area method used.

Stage / Storage Table

Stage (ft)	Elevation (ft)	Contour area (sqft)	Incr. Storage (cuft)	Total storage (cuft)
0.00	154.50	10,126	0	0
0.50	155.00	11,053	5,295	5,295
1.50	156.00	13,036	12,045	17,339
2.00	156.50	14,055	6,773	24,112

Culvert / Orifice Structures

	[A]	[B]	[C]	[D]
Rise (in)	= 18.00	6.00	0.00	0.00
Span (in)	= 18.00	6.00	0.00	0.00
No. Barrels	= 1	1	0	0
Invert El. (ft)	= 154.50	154.60	0.00	0.00
Length (ft)	= 115.00	0.00	0.00	0.00
Slope (%)	= 1.30	0.00	0.00	0.00
N-Value	= .013	.013	.000	.000
Orif. Coeff.	= 0.60	0.60	0.00	0.00
Multi-Stage	= n/a	Yes	No	No

Weir Structures

	[A]	[B]	[C]	[D]
Crest Len (ft)	= 16.00	0.00	0.00	0.00
Crest El. (ft)	= 156.50	0.00	0.00	0.00
Weir Coeff.	= 3.33	3.33	0.00	0.00
Weir Type	= Riser	---	---	---
Multi-Stage	= Yes	No	No	No

Exfiltration = 0.000 in/hr (Contour) Tailwater Elev. = 0.00 ft

Note: Culvert/Orifice outflows have been analyzed under inlet and outlet control.

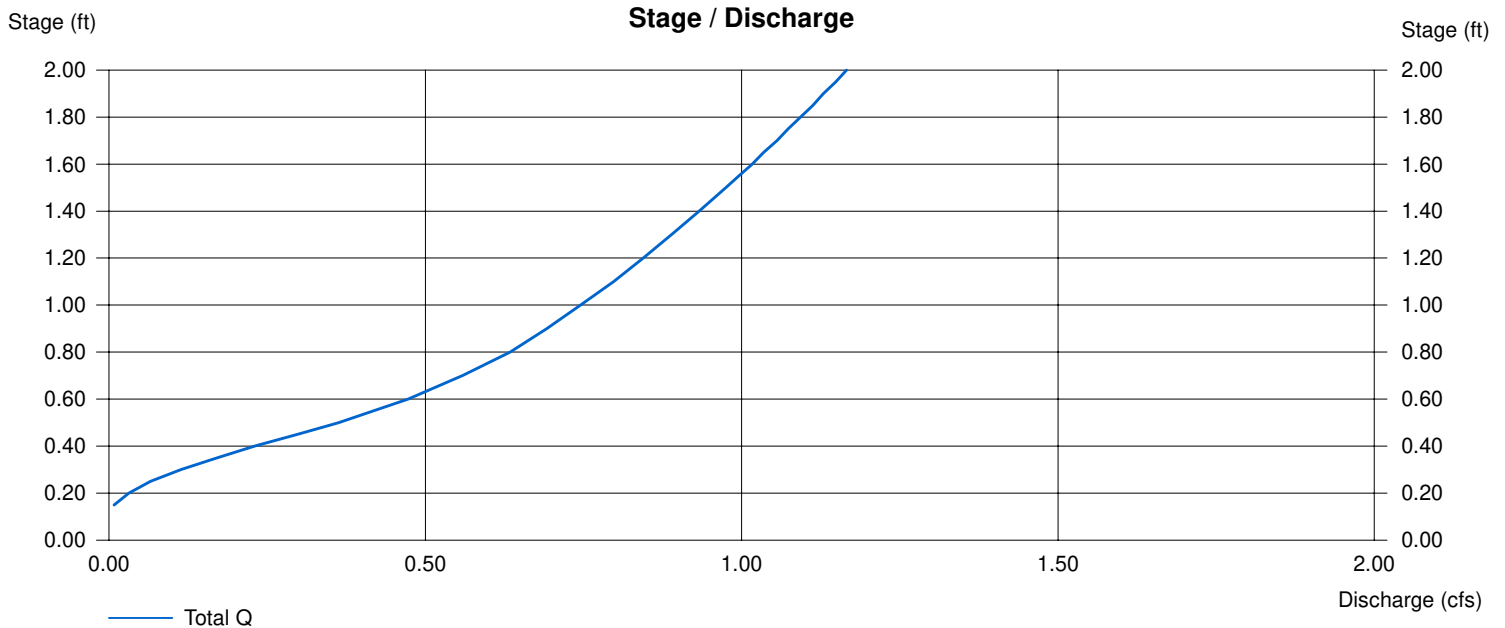

Hydrograph Plot

Hydraflow Hydrographs by Intelisolve

Tuesday, Feb 11 2020, 10:32 AM

Hyd. No. 25

Prop-B

Hydrograph type = Combine
Storm frequency = 50 yrs
Inflow hyds. = 14, 15

Peak discharge = 1.15 cfs
Time interval = 6 min

Hydrograph Volume = 32,830 cuft

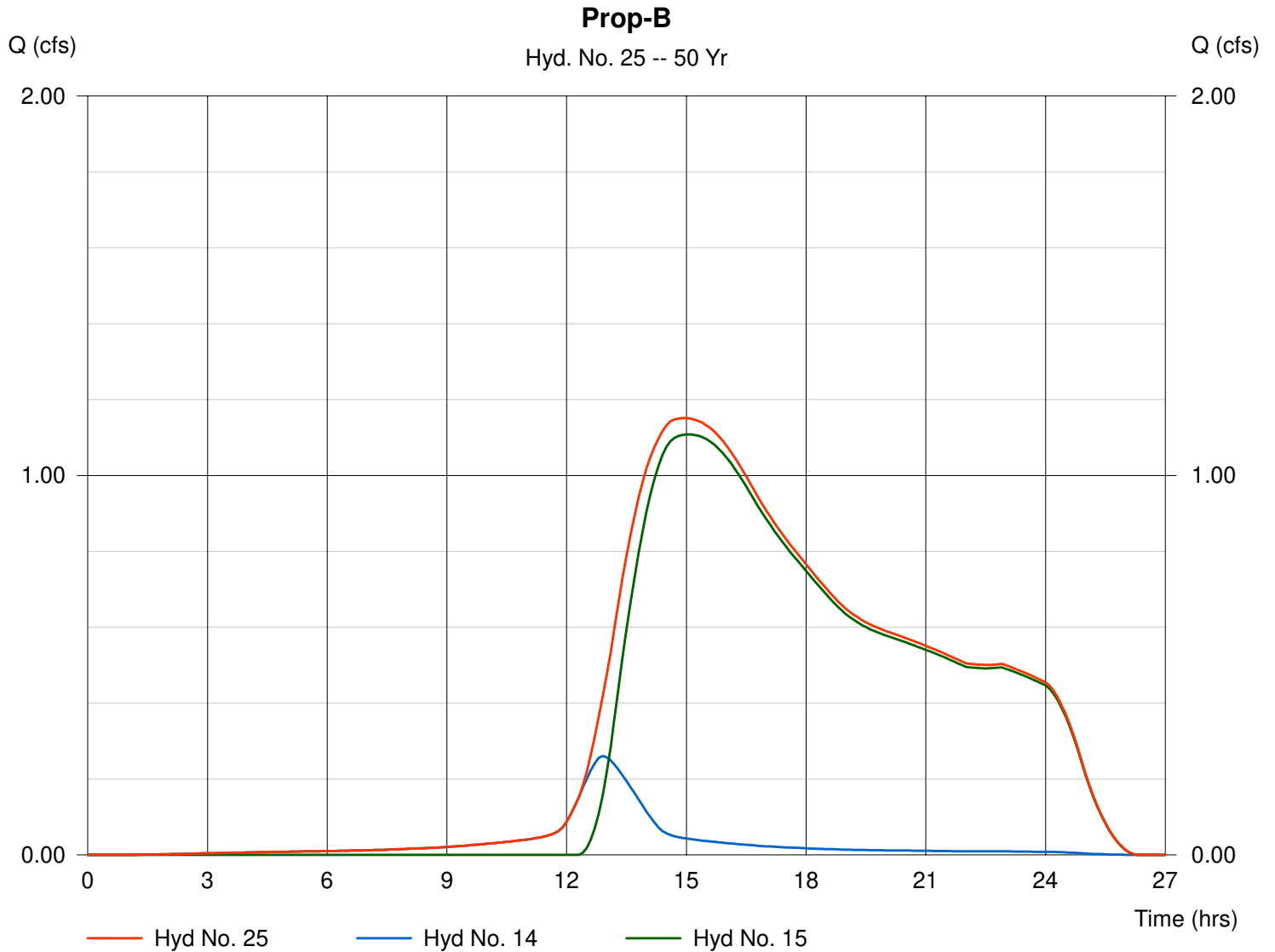

Hydrograph Plot

Hydraflow Hydrographs by Intelisolve

Tuesday, Feb 11 2020, 10:32 AM

Hyd. No. 26

Prop-B

Hydrograph type = Combine
Storm frequency = 50 yrs
Inflow hyds. = 20, 24, 25

Peak discharge = 2.53 cfs
Time interval = 6 min

Hydrograph Volume = 133,058 cuft

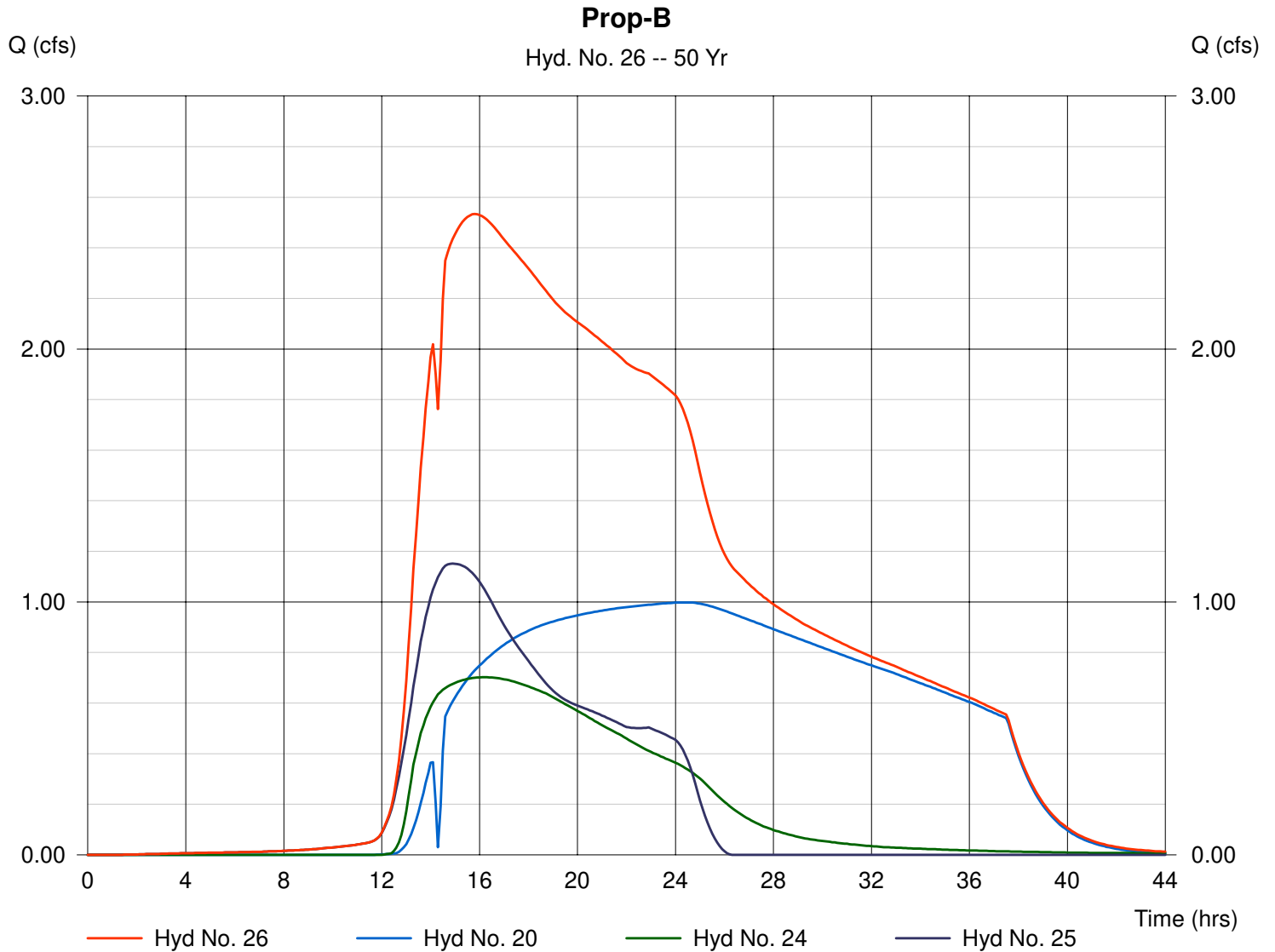

Hydrograph Plot

Hydraflow Hydrographs by Intelisolve

Tuesday, Feb 11 2020, 10:32 AM

Hyd. No. 29

Exist-C-Imp

Hydrograph type = SCS Runoff
Storm frequency = 50 yrs
Drainage area = 1.66 ac
Basin Slope = 0.0 %
Tc method = USER
Total precip. = 6.75 in
Storm duration = 24 hrs

Peak discharge = 3.87 cfs
Time interval = 6 min
Curve number = 98
Hydraulic length = 0 ft
Time of conc. (Tc) = 76.33 min
Distribution = Type III
Shape factor = 484

Hydrograph Volume = 38,622 cuft

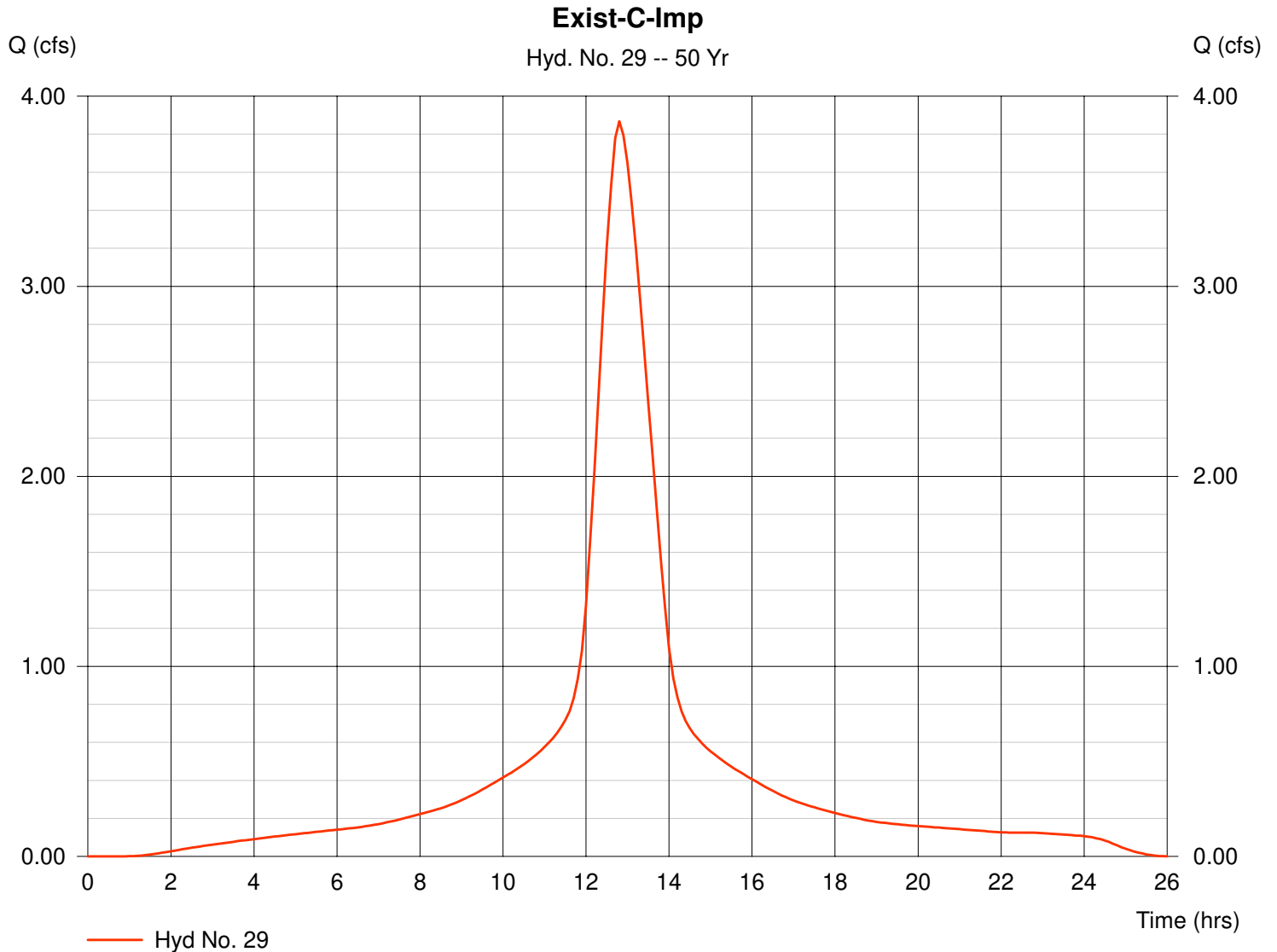

Hydrograph Plot

Hydraflow Hydrographs by Intelisolve

Tuesday, Feb 11 2020, 10:32 AM

Hyd. No. 30

Exist-C-Perv

Hydrograph type = SCS Runoff
 Storm frequency = 50 yrs
 Drainage area = 130.63 ac
 Basin Slope = 0.0 %
 Tc method = USER
 Total precip. = 6.75 in
 Storm duration = 24 hrs

Peak discharge = 23.82 cfs
 Time interval = 6 min
 Curve number = 40
 Hydraulic length = 0 ft
 Time of conc. (Tc) = 76.33 min
 Distribution = Type III
 Shape factor = 484

Hydrograph Volume = 348,921 cuft

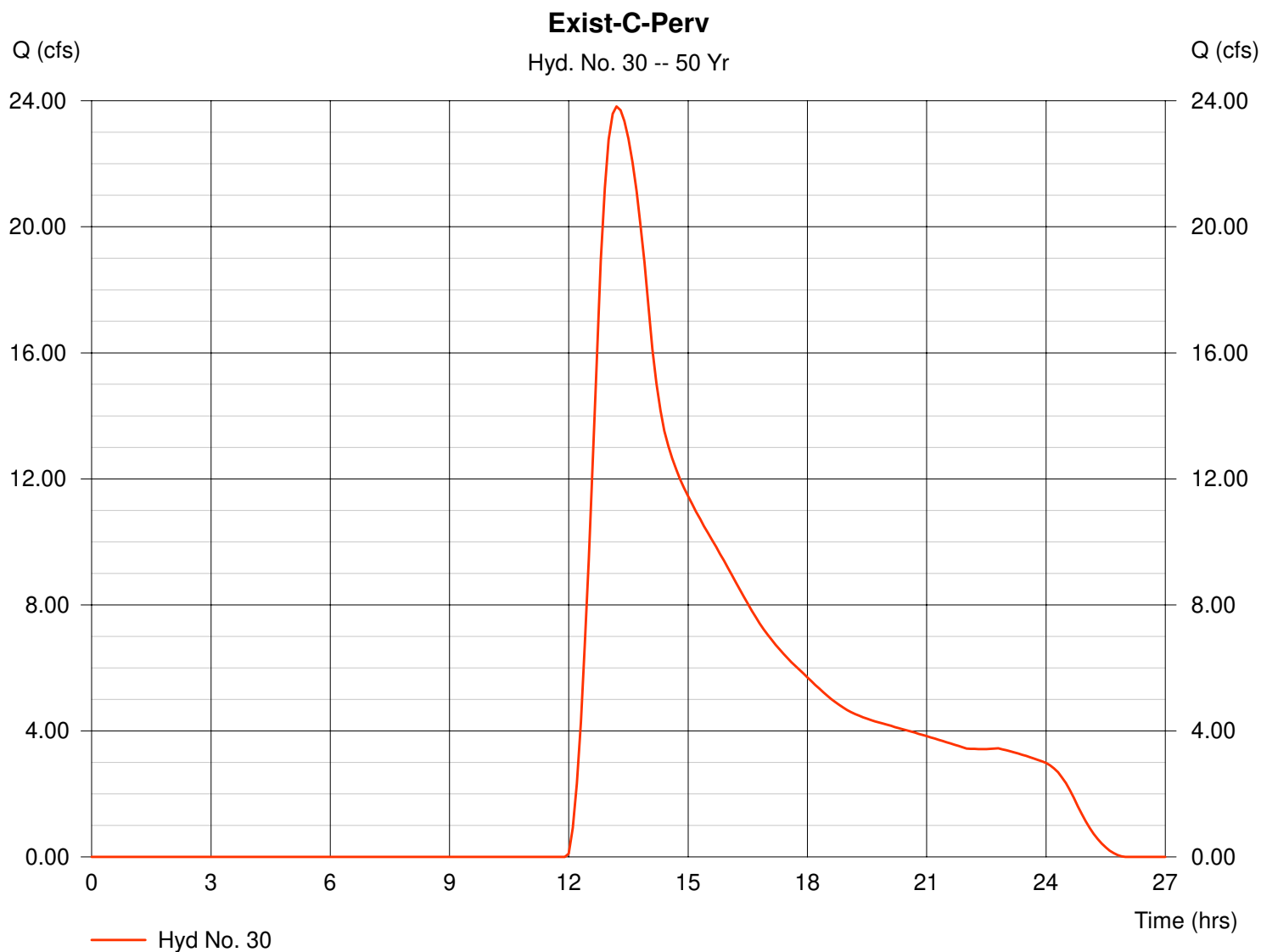

Hydrograph Plot

Hydraflow Hydrographs by Intelisolve

Tuesday, Feb 11 2020, 10:32 AM

Hyd. No. 31

Exist-C

Hydrograph type = Combine
Storm frequency = 50 yrs
Inflow hyds. = 29, 30

Peak discharge = 27.03 cfs
Time interval = 6 min

Hydrograph Volume = 387,543 cuft

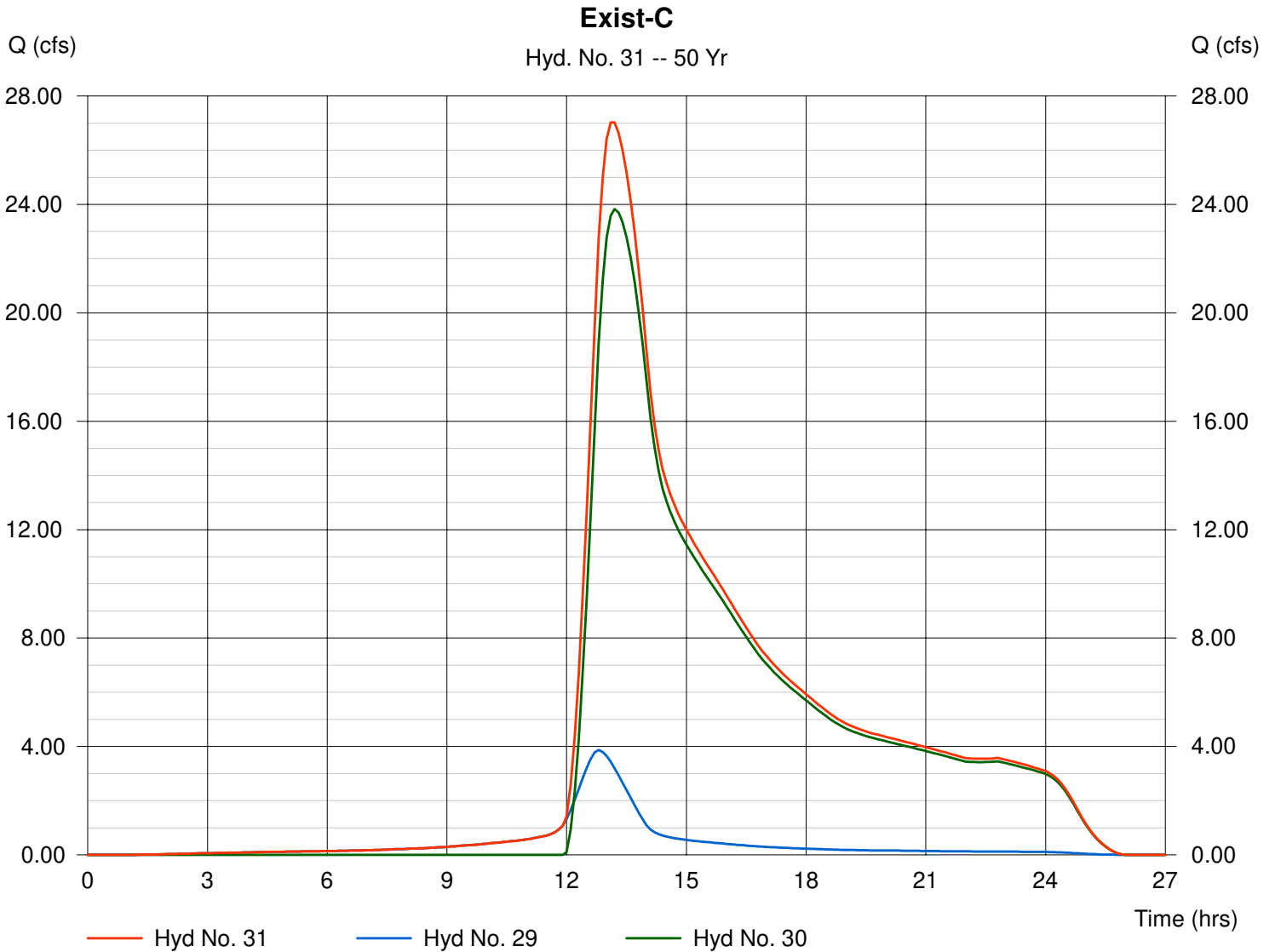

Hydrograph Plot

Hydraflow Hydrographs by Intelisolve

Tuesday, Feb 11 2020, 10:32 AM

Hyd. No. 33

Prop-C-Imp

Hydrograph type = SCS Runoff
Storm frequency = 50 yrs
Drainage area = 1.42 ac
Basin Slope = 0.0 %
Tc method = USER
Total precip. = 6.75 in
Storm duration = 24 hrs

Peak discharge = 3.31 cfs
Time interval = 6 min
Curve number = 98
Hydraulic length = 0 ft
Time of conc. (Tc) = 75.49 min
Distribution = Type III
Shape factor = 484

Hydrograph Volume = 33,038 cuft

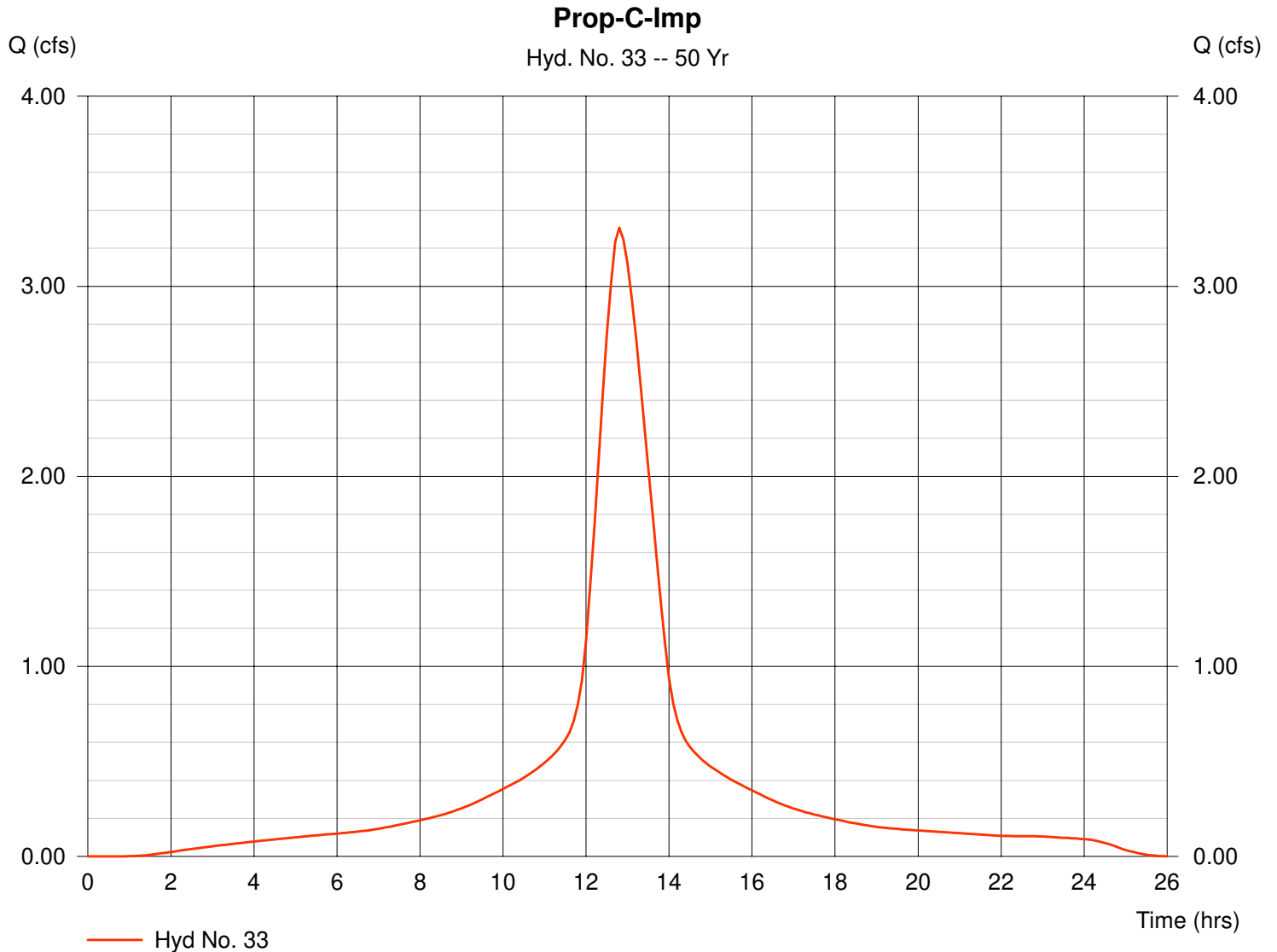

Hydrograph Plot

Hydraflow Hydrographs by Intelisolve

Tuesday, Feb 11 2020, 10:32 AM

Hyd. No. 34

Prop-C-Perv

Hydrograph type = SCS Runoff
 Storm frequency = 50 yrs
 Drainage area = 133.04 ac
 Basin Slope = 0.0 %
 Tc method = USER
 Total precip. = 6.75 in
 Storm duration = 24 hrs

Peak discharge = 24.26 cfs
 Time interval = 6 min
 Curve number = 40
 Hydraulic length = 0 ft
 Time of conc. (Tc) = 75.49 min
 Distribution = Type III
 Shape factor = 484

Hydrograph Volume = 355,358 cuft

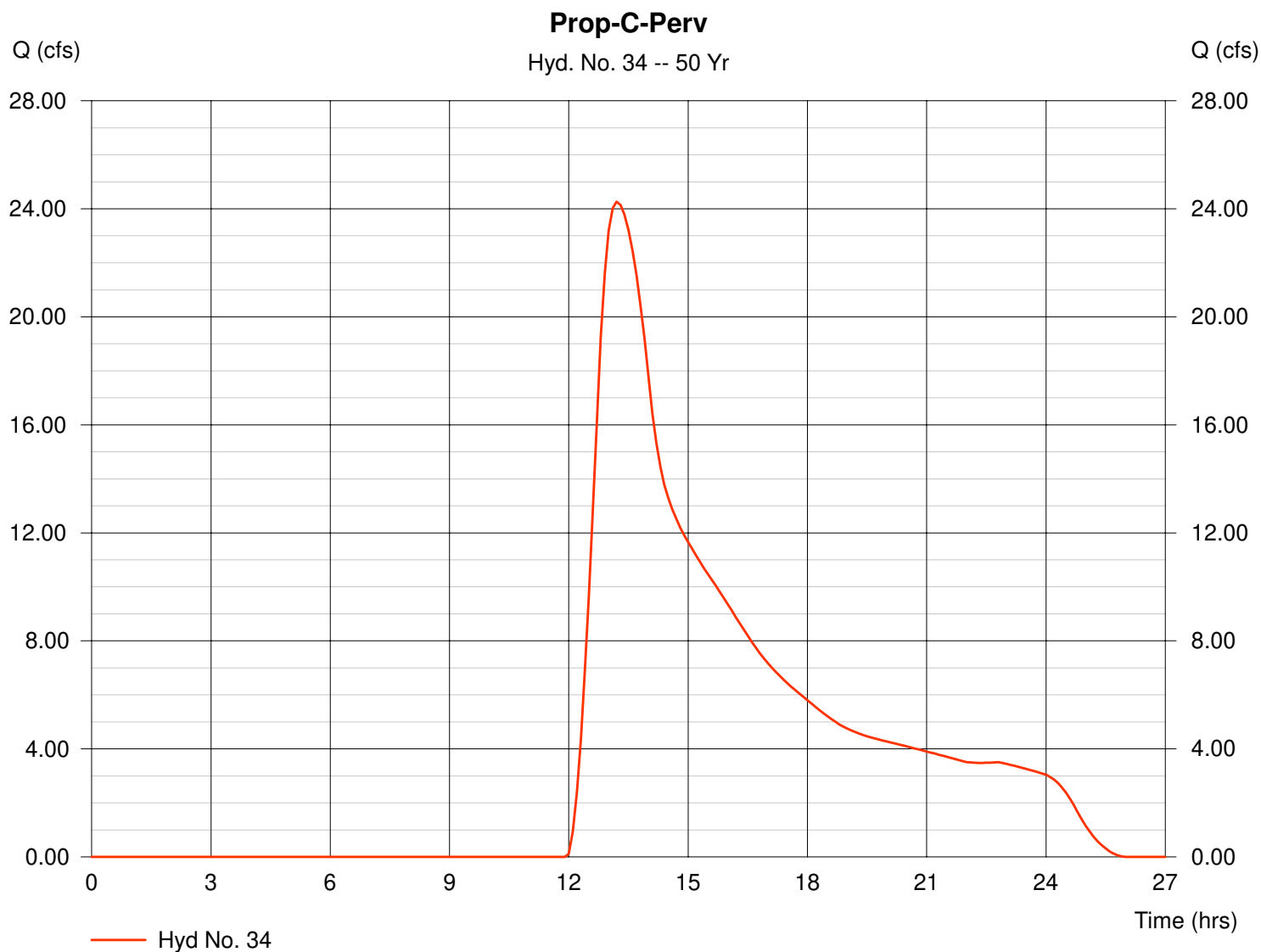

Hydrograph Plot

Hydraflow Hydrographs by Intelisolve

Tuesday, Feb 11 2020, 10:32 AM

Hyd. No. 35

Prop-C

Hydrograph type = Combine
Storm frequency = 50 yrs
Inflow hyds. = 33, 34

Peak discharge = 27.00 cfs
Time interval = 6 min

Hydrograph Volume = 388,396 cuft

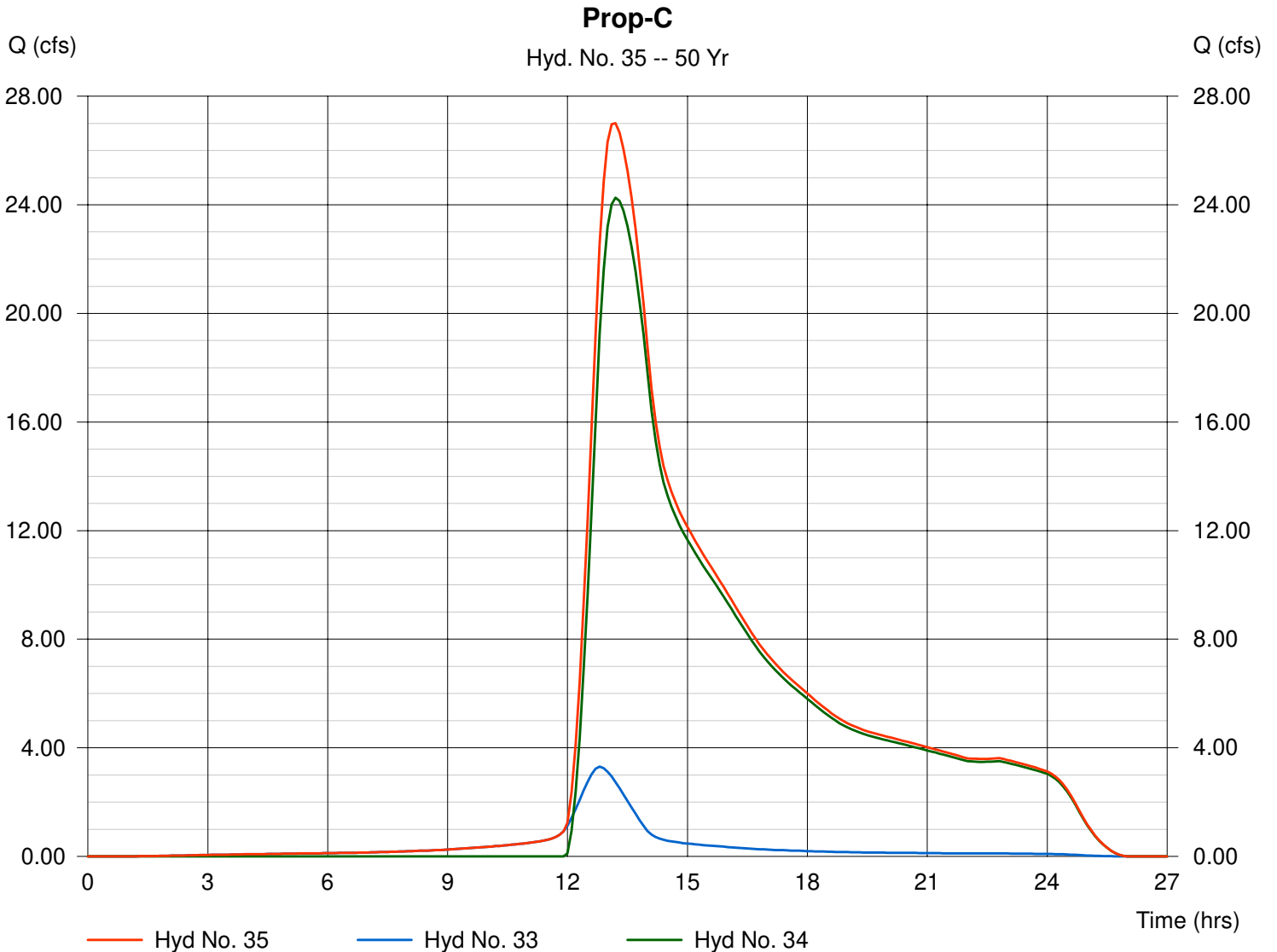

Hydrograph Summary Report

Hyd. No.	Hydrograph type (origin)	Peak flow (cfs)	Time interval (min)	Time to peak (min)	Volume (cuft)	Inflow hyd(s)	Maximum elevation (ft)	Maximum storage (cuft)	Hydrograph description
1	SCS Runoff	6.01	6	780	70,642	---	-----	-----	Exist-A-Imp
2	SCS Runoff	27.70	6	810	438,091	---	-----	-----	Exist-A-Perv
3	Combine	32.99	6	804	508,733	1, 2	-----	-----	Exist-A
5	SCS Runoff	5.80	6	774	63,163	---	-----	-----	Prop-A-Imp
6	SCS Runoff	30.73	6	798	435,061	---	-----	-----	Prop-A-Perv
7	Combine	35.94	6	792	498,225	5, 6	-----	-----	Prop-A
10	SCS Runoff	5.68	6	774	61,842	---	-----	-----	Exist-B-Imp
11	SCS Runoff	5.57	6	864	140,286	---	-----	-----	Exist-B-Perv
12	Combine	8.39	6	810	202,128	10, 11	-----	-----	Exist-B
14	SCS Runoff	0.29	6	774	3,171	---	-----	-----	Prop-B-Imp
15	SCS Runoff	2.20	6	852	51,809	---	-----	-----	Prop-B-Perv
17	SCS Runoff	1.52	6	774	16,544	---	-----	-----	Prop-B-Imp-FAN-Basin
18	SCS Runoff	6.04	6	840	132,403	---	-----	-----	Prop-B-Perv-FAN-Basin
19	Combine	6.84	6	822	148,947	17, 18	-----	-----	FAN Basin Inflow
20	Reservoir	2.33	6	1146	126,697	19	156.32	80,825	FAN Basin 1 Routing
21	SCS Runoff	0.49	6	774	5,286	---	-----	-----	Prop-B-Imp-ROCA-Basin
22	SCS Runoff	2.24	6	798	34,456	---	-----	-----	Prop-B-Perv-ROCA-Basin
23	Combine	2.65	6	798	39,741	21, 22	-----	-----	ROCA Basin Inflow
24	Reservoir	0.91	6	978	38,614	23	155.85	15,477	ROCA Basin Routing
25	Combine	2.31	6	840	54,981	14, 15,	-----	-----	Prop-B
26	Combine	4.20	6	1092	220,292	20, 24, 25	-----	-----	Prop-B
29	SCS Runoff	4.31	6	768	43,185	---	-----	-----	Exist-C-Imp
30	SCS Runoff	37.55	6	786	488,040	---	-----	-----	Exist-C-Perv
31	Combine	41.38	6	786	531,225	29, 30	-----	-----	Exist-C

Hydrograph Summary Report

Hyd. No.	Hydrograph type (origin)	Peak flow (cfs)	Time interval (min)	Time to peak (min)	Volume (cuft)	Inflow hyd(s)	Maximum elevation (ft)	Maximum storage (cuft)	Hydrograph description
33	SCS Runoff	3.69	6	768	36,942	---	-----	-----	Prop-C-Imp
34	SCS Runoff	38.24	6	786	497,044	---	-----	-----	Prop-C-Perv
35	Combine	41.52	6	786	533,986	33, 34	-----	-----	Prop-C
Camp Edwards Joint Base Cape Cod						Retention Pond #10		Tuesday, Feb 11 2020, 10:32 AM	

Hydrograph Plot

Hydraflow Hydrographs by Intelisolve

Tuesday, Feb 11 2020, 10:32 AM

Hyd. No. 1

Exist-A-Imp

Hydrograph type = SCS Runoff
Storm frequency = 100 yrs
Drainage area = 2.64 ac
Basin Slope = 0.0 %
Tc method = USER
Total precip. = 7.52 in
Storm duration = 24 hrs

Peak discharge = 6.01 cfs
Time interval = 6 min
Curve number = 98
Hydraulic length = 0 ft
Time of conc. (Tc) = 91.29 min
Distribution = Type III
Shape factor = 484

Hydrograph Volume = 70,642 cuft

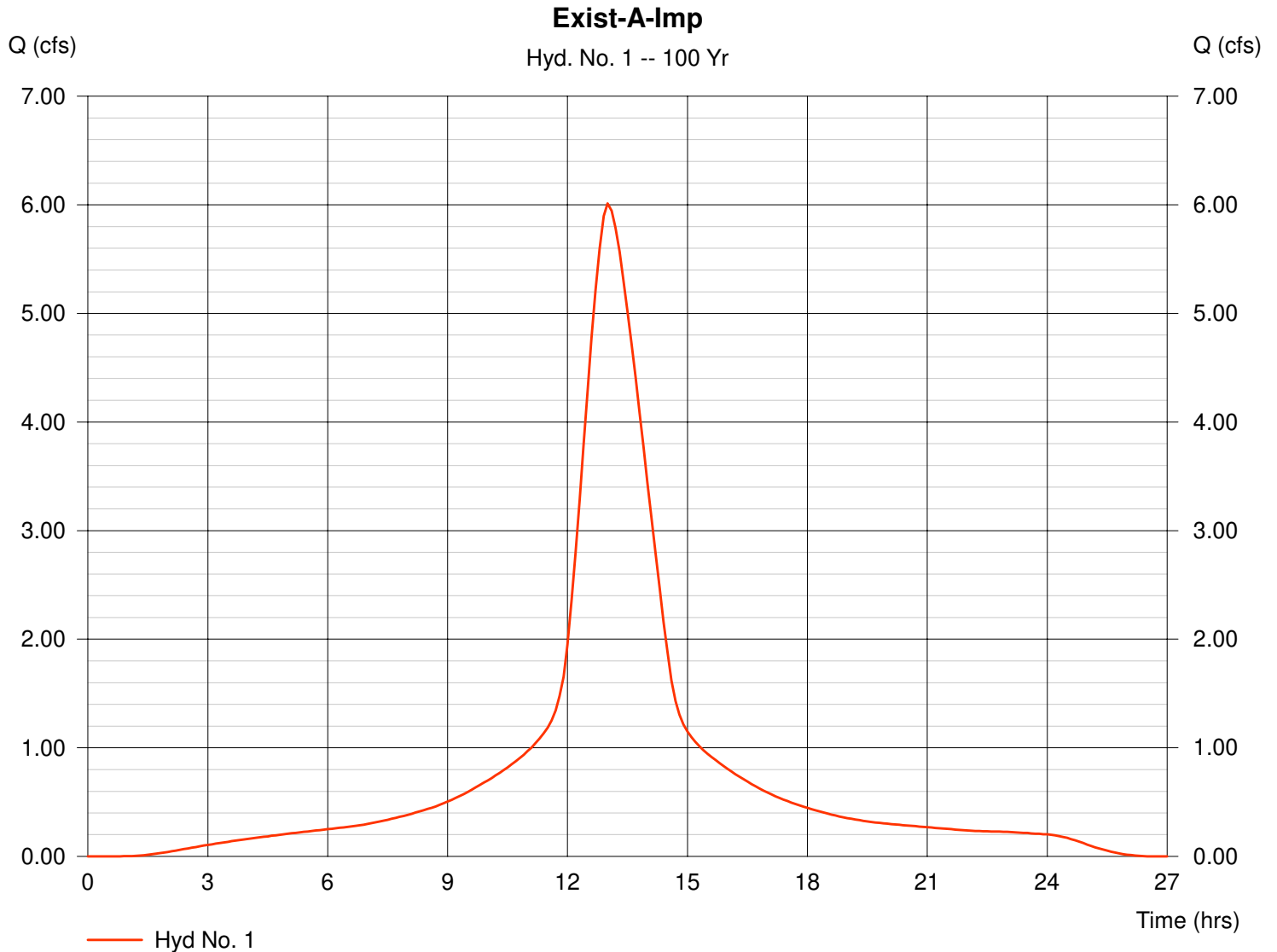

Hydrograph Plot

Hydraflow Hydrographs by Intelisolve

Tuesday, Feb 11 2020, 10:32 AM

Hyd. No. 2

Exist-A-Perv

Hydrograph type = SCS Runoff
Storm frequency = 100 yrs
Drainage area = 123.80 ac
Basin Slope = 0.0 %
Tc method = USER
Total precip. = 7.52 in
Storm duration = 24 hrs

Peak discharge = 27.70 cfs
Time interval = 6 min
Curve number = 39
Hydraulic length = 0 ft
Time of conc. (Tc) = 91.29 min
Distribution = Type III
Shape factor = 484

Hydrograph Volume = 438,091 cuft

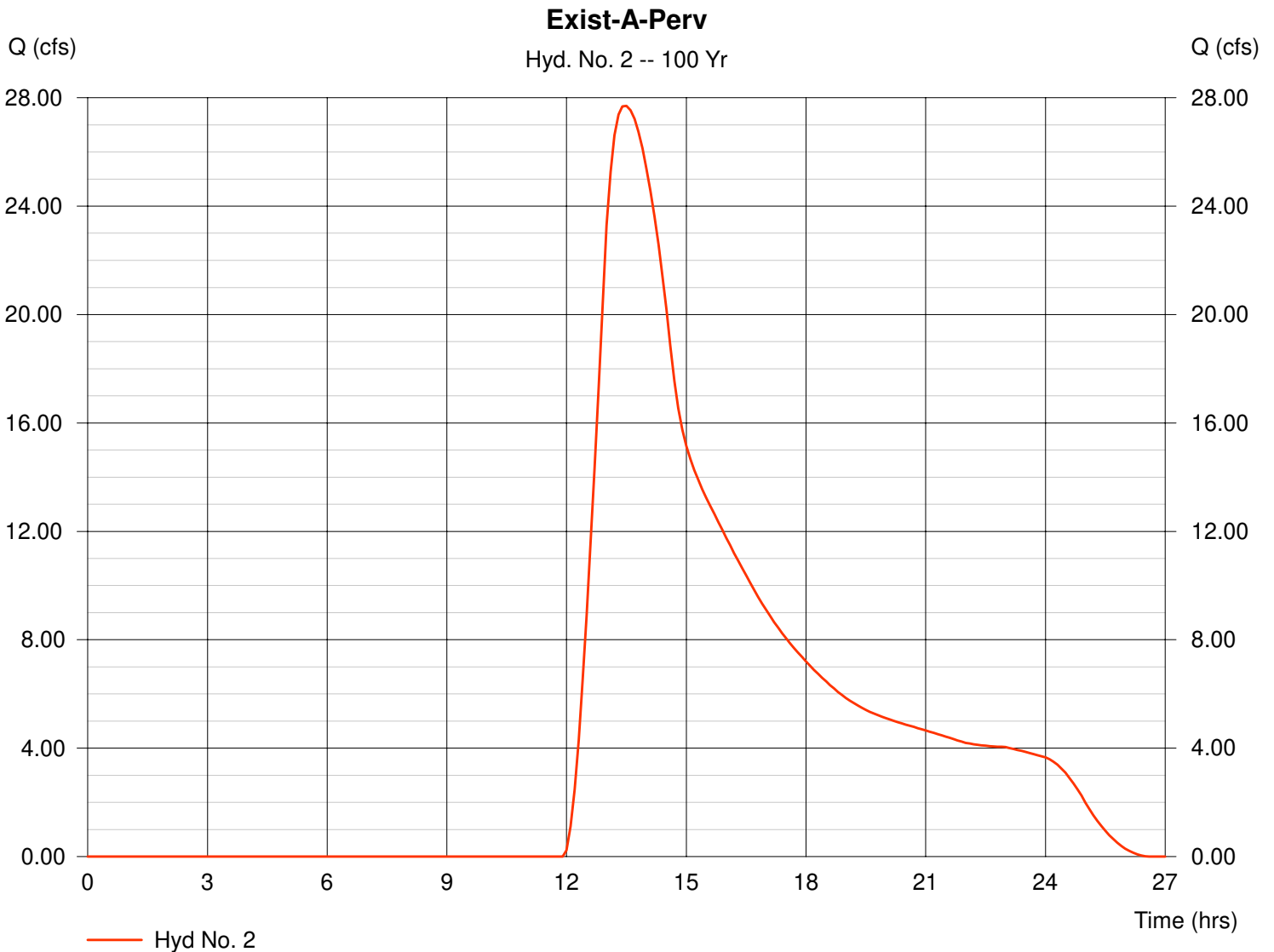

Hydrograph Plot

Hydraflow Hydrographs by Intelisolve

Tuesday, Feb 11 2020, 10:32 AM

Hyd. No. 3

Exist-A

Hydrograph type = Combine
Storm frequency = 100 yrs
Inflow hyds. = 1, 2

Peak discharge = 32.99 cfs
Time interval = 6 min

Hydrograph Volume = 508,733 cuft

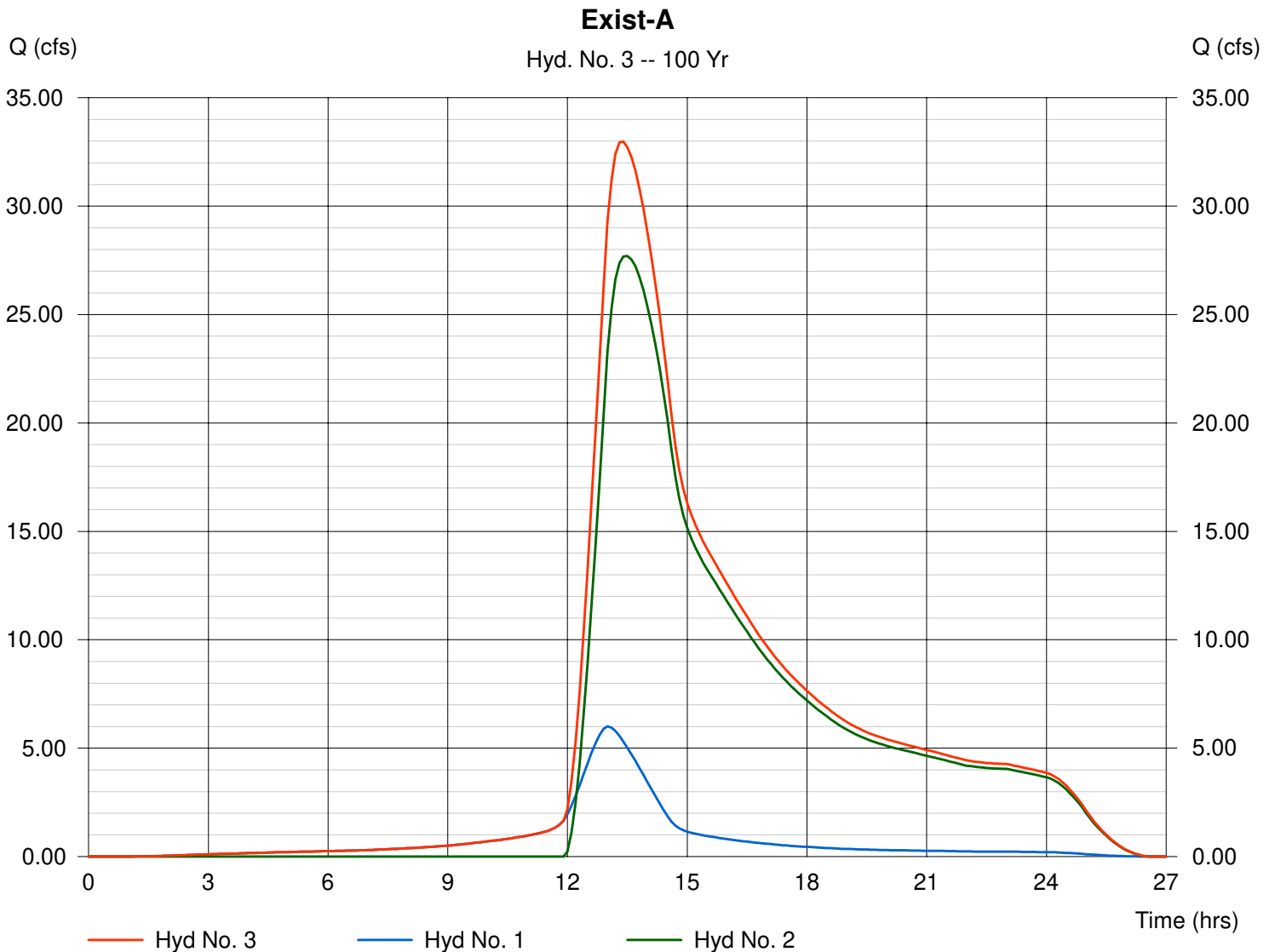

Hydrograph Plot

Hydraflow Hydrographs by Intelisolve

Tuesday, Feb 11 2020, 10:32 AM

Hyd. No. 5

Prop-A-Imp

Hydrograph type = SCS Runoff
Storm frequency = 100 yrs
Drainage area = 2.39 ac
Basin Slope = 0.0 %
Tc method = USER
Total precip. = 7.52 in
Storm duration = 24 hrs

Peak discharge = 5.80 cfs
Time interval = 6 min
Curve number = 98
Hydraulic length = 0 ft
Time of conc. (Tc) = 90.72 min
Distribution = Type III
Shape factor = 484

Hydrograph Volume = 63,163 cuft

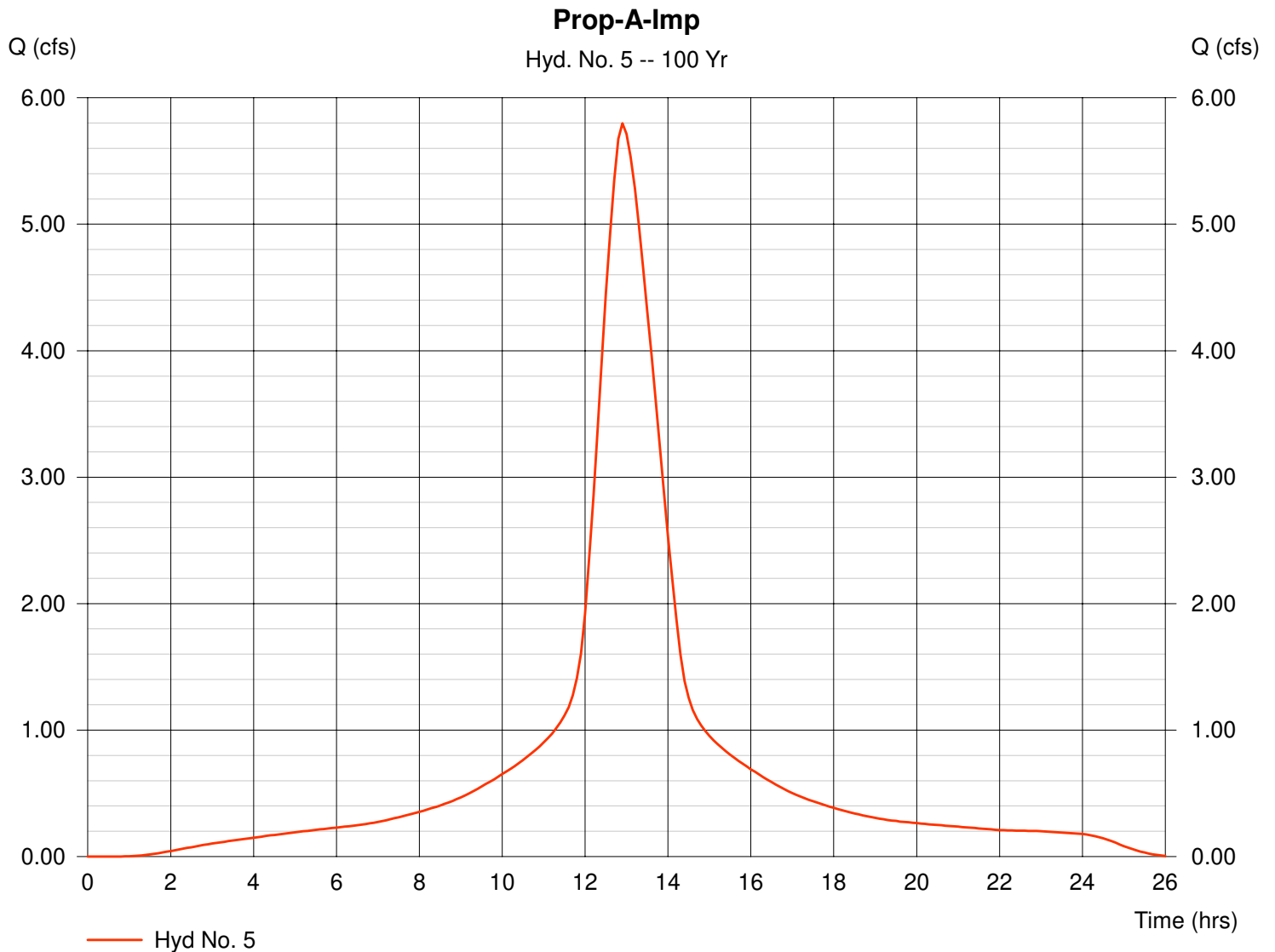

Hydrograph Plot

Hydraflow Hydrographs by Intelisolve

Tuesday, Feb 11 2020, 10:32 AM

Hyd. No. 6

Prop-A-Perv

Hydrograph type = SCS Runoff
Storm frequency = 100 yrs
Drainage area = 114.63 ac
Basin Slope = 0.0 %
Tc method = USER
Total precip. = 7.52 in
Storm duration = 24 hrs

Peak discharge = 30.73 cfs
Time interval = 6 min
Curve number = 40
Hydraulic length = 0 ft
Time of conc. (Tc) = 90.7 min
Distribution = Type III
Shape factor = 484

Hydrograph Volume = 435,061 cuft

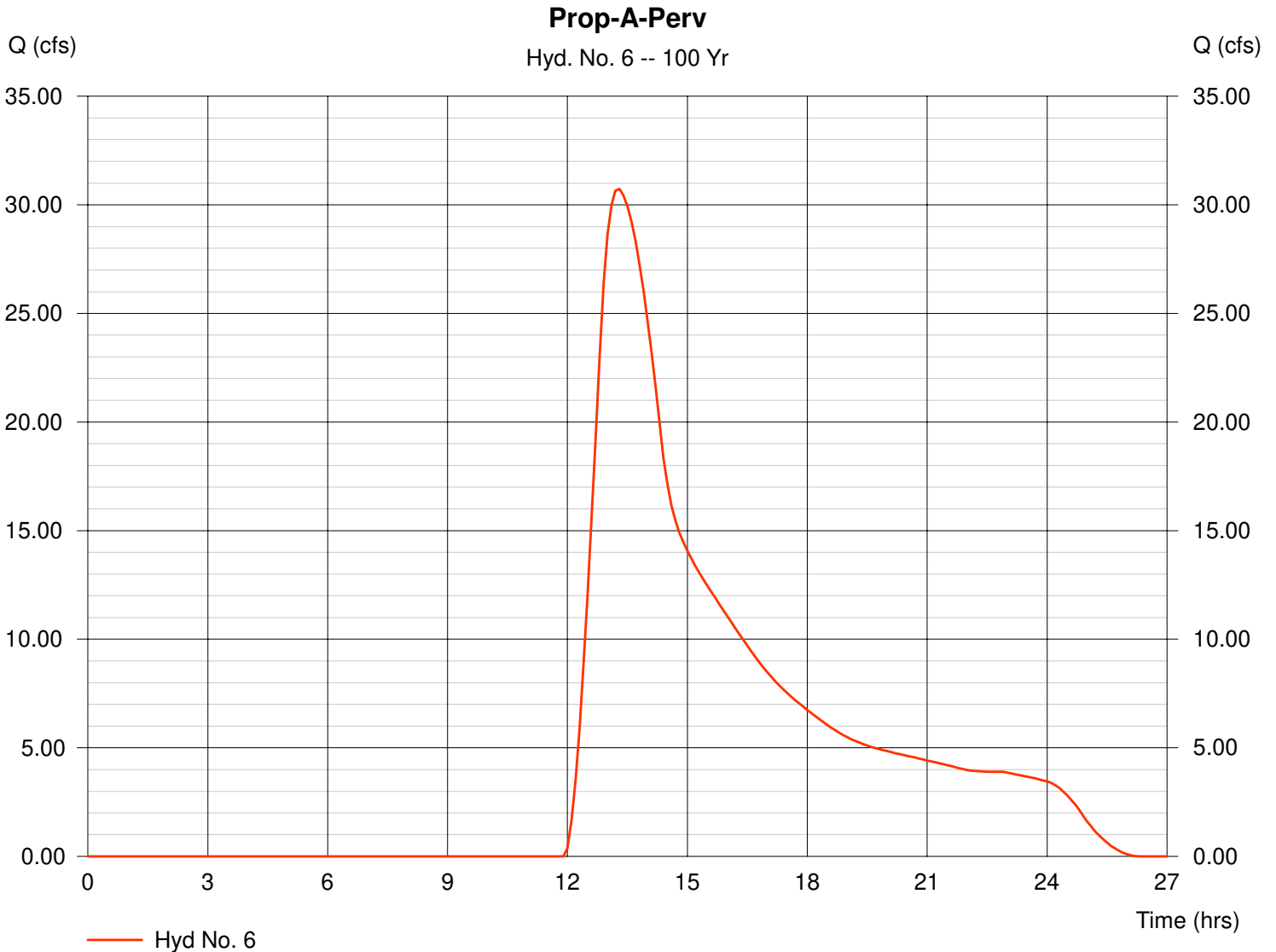

Hydrograph Plot

Hydraflow Hydrographs by Intelisolve

Tuesday, Feb 11 2020, 10:32 AM

Hyd. No. 7

Prop-A

Hydrograph type = Combine
Storm frequency = 100 yrs
Inflow hyds. = 5, 6

Peak discharge = 35.94 cfs
Time interval = 6 min

Hydrograph Volume = 498,225 cuft

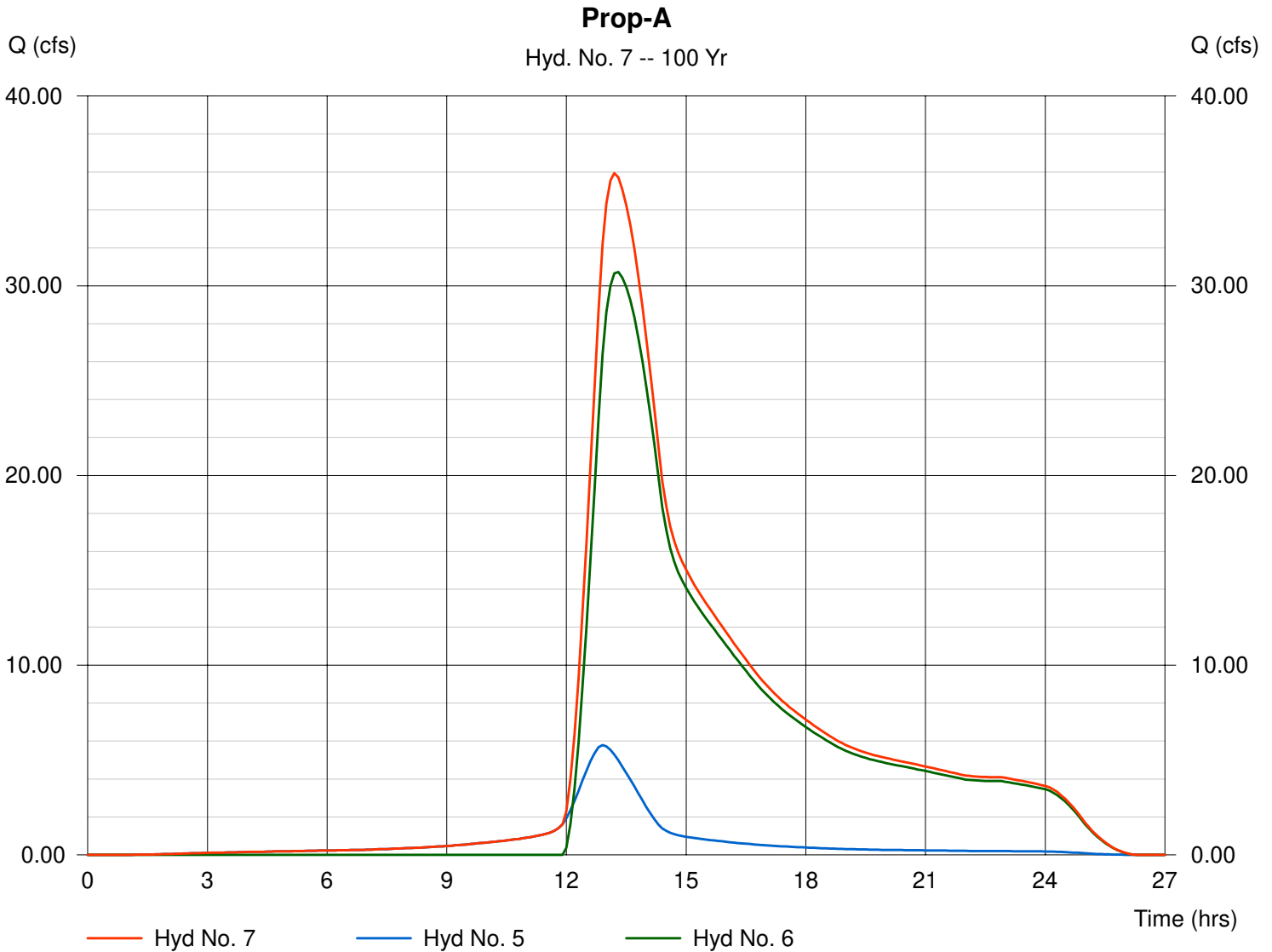

Hydrograph Plot

Hydraflow Hydrographs by Intelisolve

Tuesday, Feb 11 2020, 10:32 AM

Hyd. No. 10

Exist-B-Imp

Hydrograph type = SCS Runoff
 Storm frequency = 100 yrs
 Drainage area = 2.34 ac
 Basin Slope = 0.0 %
 Tc method = USER
 Total precip. = 7.52 in
 Storm duration = 24 hrs

Peak discharge = 5.68 cfs
 Time interval = 6 min
 Curve number = 98
 Hydraulic length = 0 ft
 Time of conc. (Tc) = 87.72 min
 Distribution = Type III
 Shape factor = 484

Hydrograph Volume = 61,842 cuft

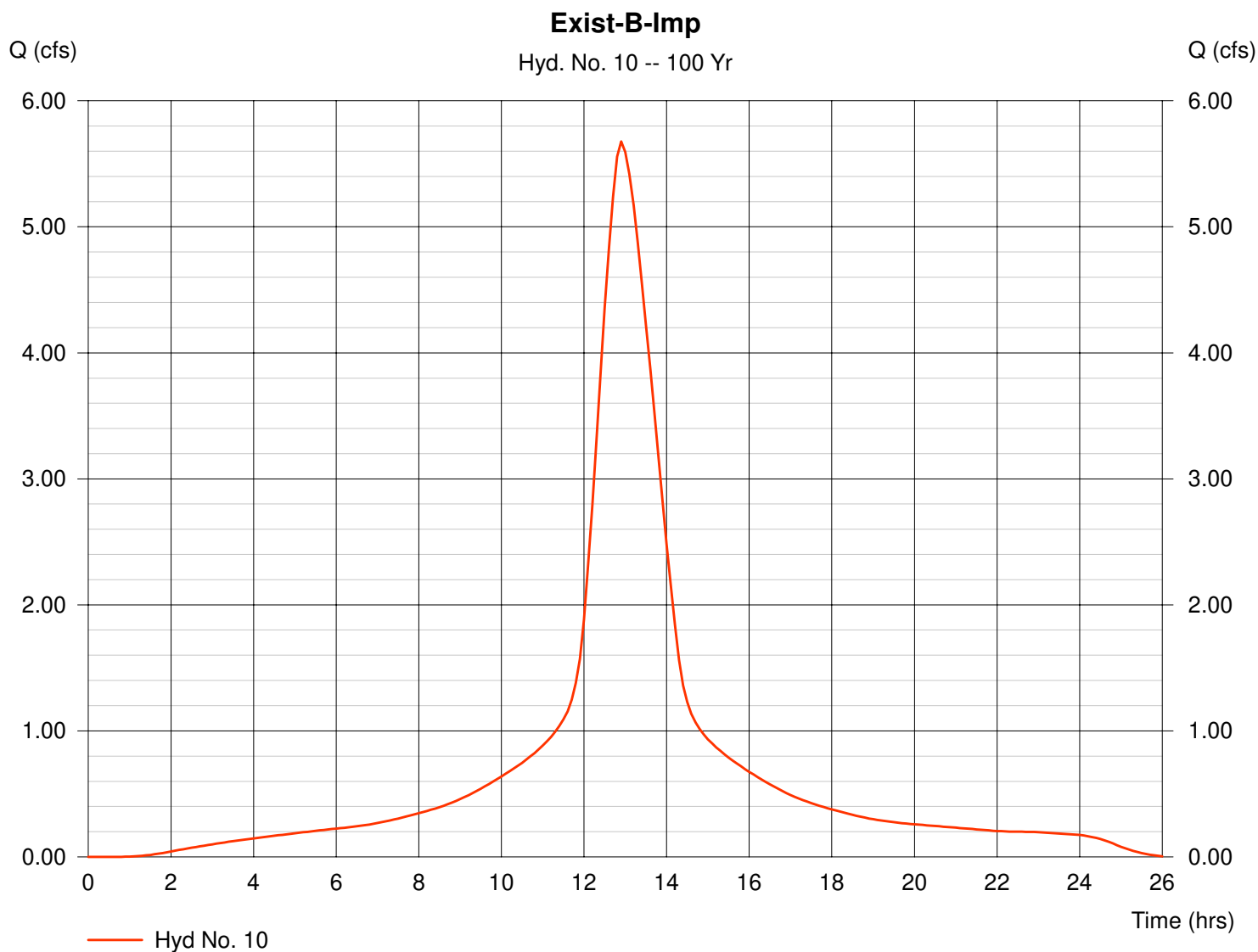

Hydrograph Plot

Hydraflow Hydrographs by Intelisolve

Tuesday, Feb 11 2020, 10:32 AM

Hyd. No. 11

Exist-B-Perv

Hydrograph type = SCS Runoff
Storm frequency = 100 yrs
Drainage area = 124.34 ac
Basin Slope = 0.0 %
Tc method = USER
Total precip. = 7.52 in
Storm duration = 24 hrs

Peak discharge = 5.57 cfs
Time interval = 6 min
Curve number = 30
Hydraulic length = 0 ft
Time of conc. (Tc) = 87.7 min
Distribution = Type III
Shape factor = 484

Hydrograph Volume = 140,286 cuft

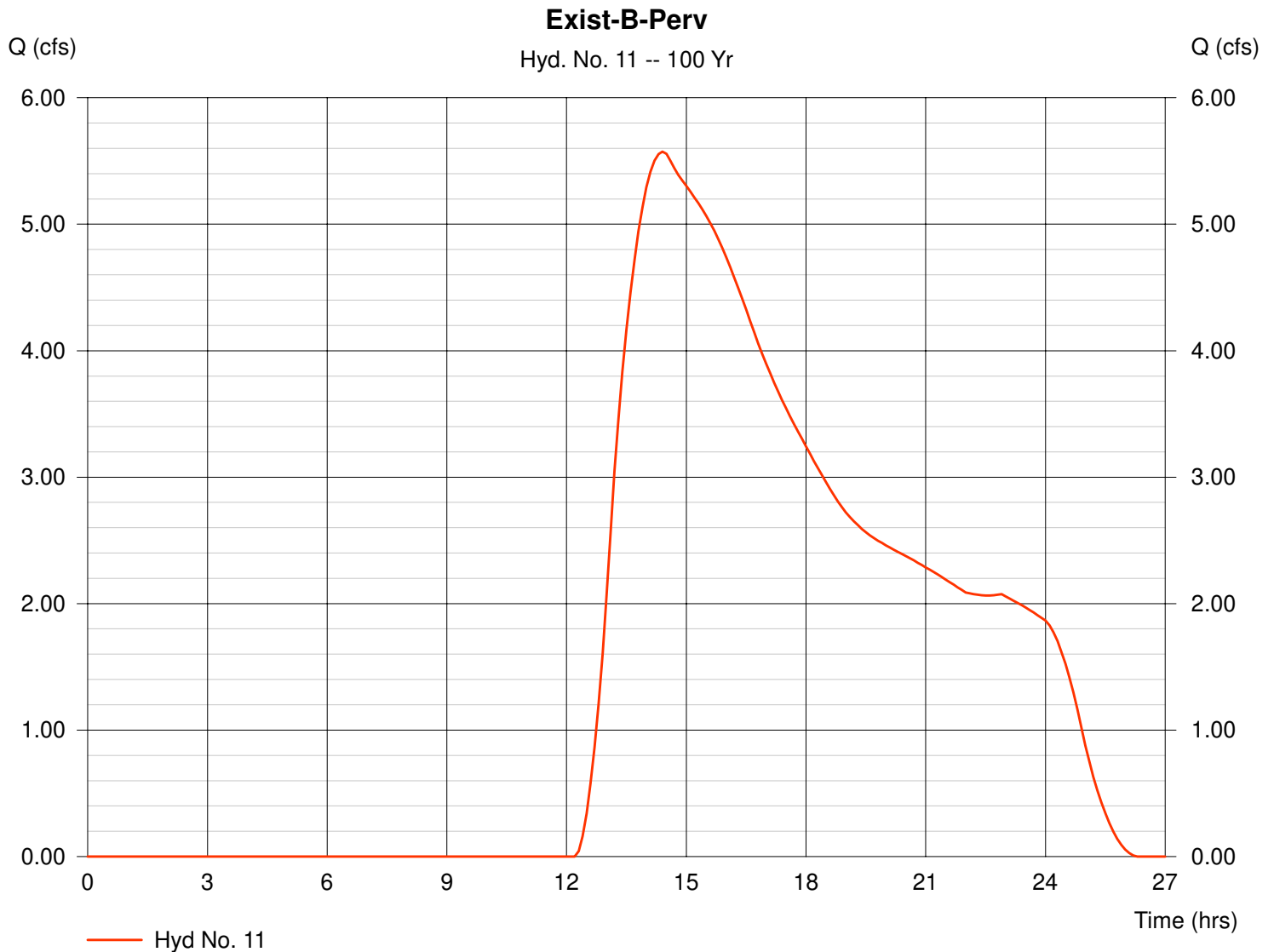

Hydrograph Plot

Hydraflow Hydrographs by Intelisolve

Tuesday, Feb 11 2020, 10:32 AM

Hyd. No. 12

Exist-B

Hydrograph type = Combine
Storm frequency = 100 yrs
Inflow hyds. = 10, 11

Peak discharge = 8.39 cfs
Time interval = 6 min

Hydrograph Volume = 202,128 cuft

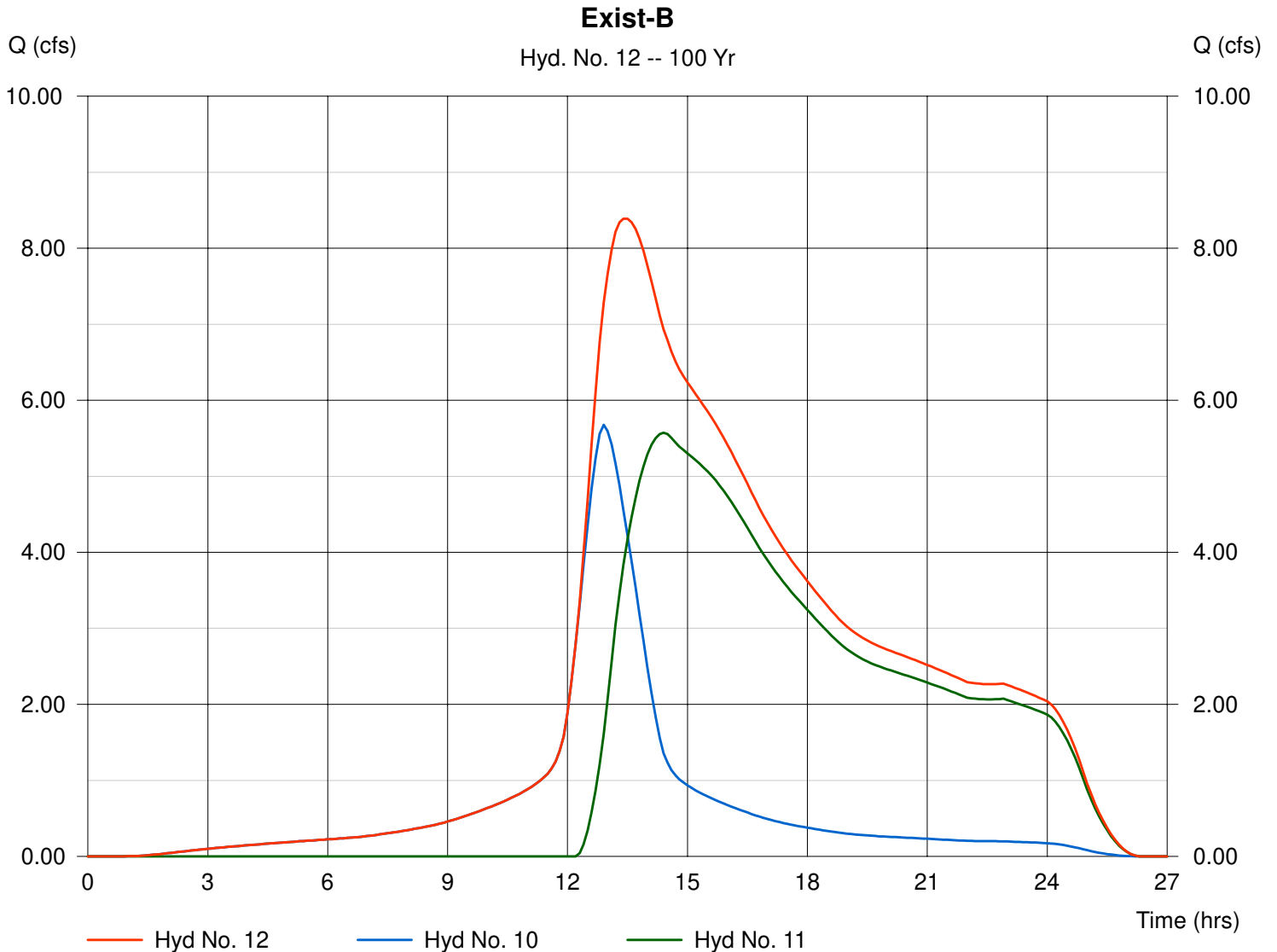

Hydrograph Plot

Hydraflow Hydrographs by Intelisolve

Tuesday, Feb 11 2020, 10:32 AM

Hyd. No. 14

Prop-B-Imp

Hydrograph type = SCS Runoff
 Storm frequency = 100 yrs
 Drainage area = 0.12 ac
 Basin Slope = 0.0 %
 Tc method = USER
 Total precip. = 7.52 in
 Storm duration = 24 hrs

Peak discharge = 0.29 cfs
 Time interval = 6 min
 Curve number = 98
 Hydraulic length = 0 ft
 Time of conc. (Tc) = 82.7 min
 Distribution = Type III
 Shape factor = 484

Hydrograph Volume = 3,171 cuft

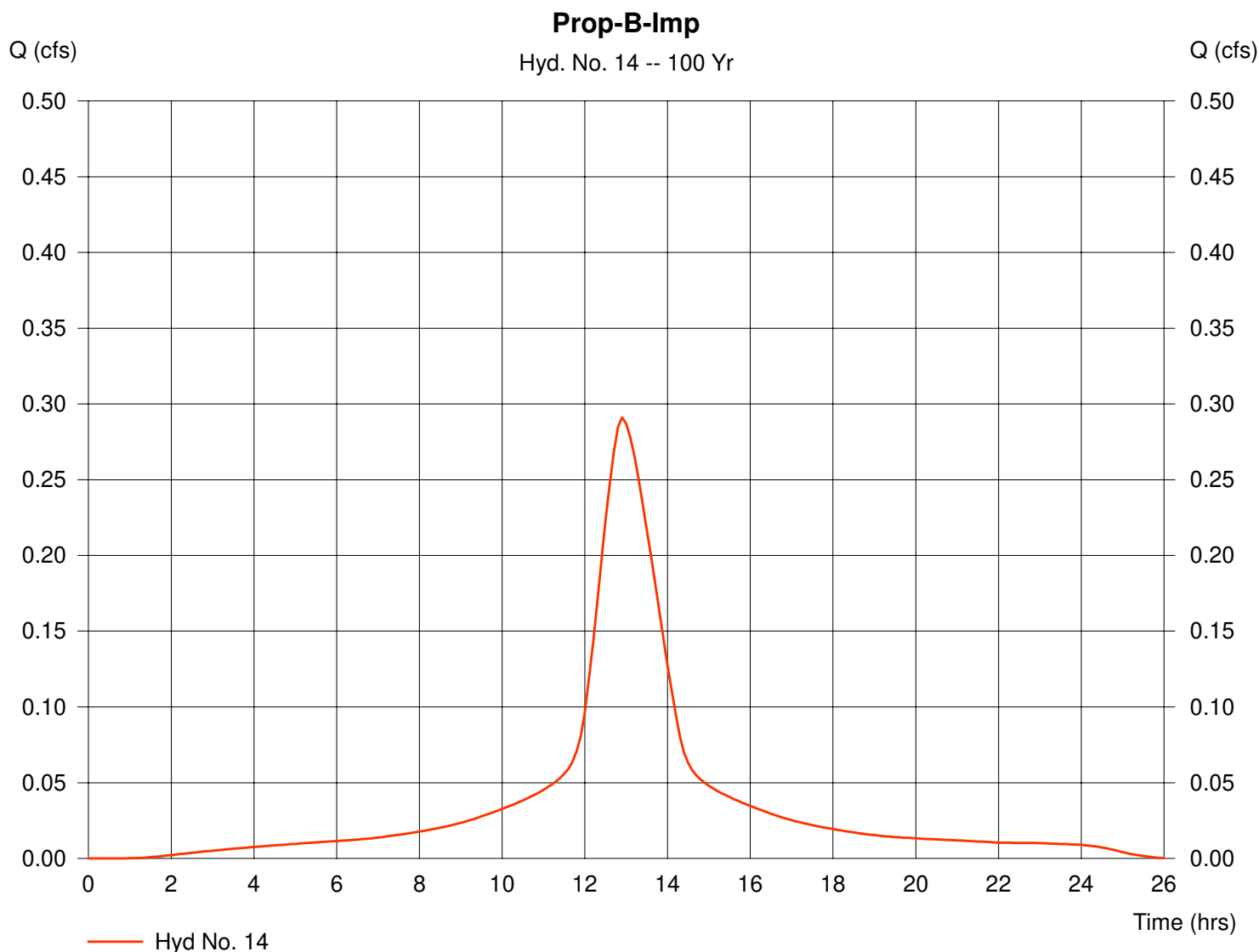

Hydrograph Plot

Hydraflow Hydrographs by Intelisolve

Tuesday, Feb 11 2020, 10:32 AM

Hyd. No. 15

Prop-B-Perv

Hydrograph type = SCS Runoff
Storm frequency = 100 yrs
Drainage area = 38.41 ac
Basin Slope = 0.0 %
Tc method = USER
Total precip. = 7.52 in
Storm duration = 24 hrs

Peak discharge = 2.20 cfs
Time interval = 6 min
Curve number = 31
Hydraulic length = 0 ft
Time of conc. (Tc) = 82.7 min
Distribution = Type III
Shape factor = 484

Hydrograph Volume = 51,809 cuft



Hydrograph Plot

Hydraflow Hydrographs by Intelisolve

Tuesday, Feb 11 2020, 10:32 AM

Hyd. No. 17

Prop-B-Imp-FAN-Basin

Hydrograph type = SCS Runoff
Storm frequency = 100 yrs
Drainage area = 0.63 ac
Basin Slope = 0.0 %
Tc method = USER
Total precip. = 7.52 in
Storm duration = 24 hrs

Peak discharge = 1.52 cfs
Time interval = 6 min
Curve number = 98
Hydraulic length = 0 ft
Time of conc. (Tc) = 82.7 min
Distribution = Type III
Shape factor = 484

Hydrograph Volume = 16,544 cuft

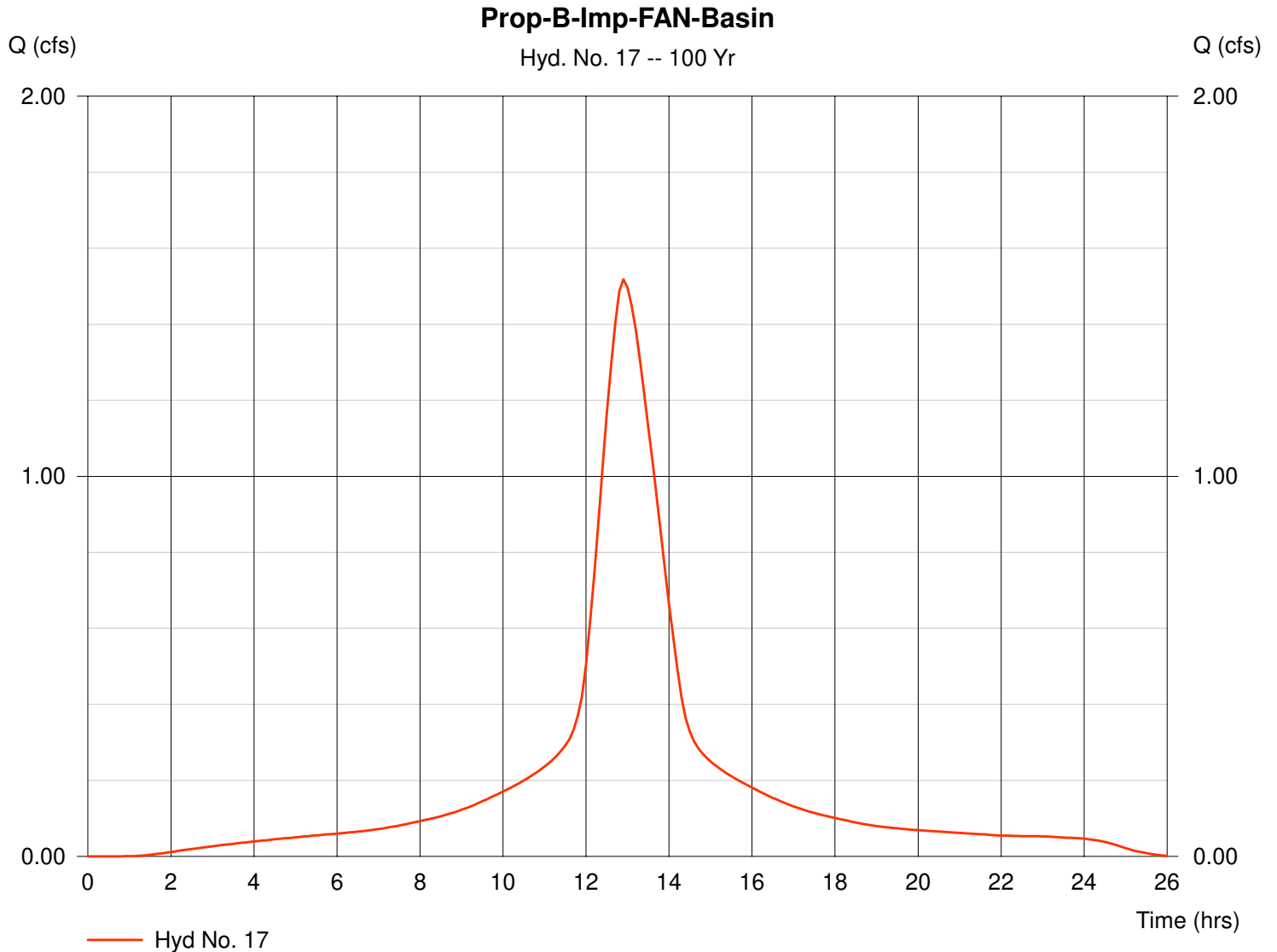

Hydrograph Plot

Hydraflow Hydrographs by Intelisolve

Tuesday, Feb 11 2020, 10:32 AM

Hyd. No. 18

Prop-B-Perv-FAN-Basin

Hydrograph type = SCS Runoff
Storm frequency = 100 yrs
Drainage area = 83.82 ac
Basin Slope = 0.0 %
Tc method = USER
Total precip. = 7.52 in
Storm duration = 24 hrs

Peak discharge = 6.04 cfs
Time interval = 6 min
Curve number = 32
Hydraulic length = 0 ft
Time of conc. (Tc) = 82.7 min
Distribution = Type III
Shape factor = 484

Hydrograph Volume = 132,403 cuft

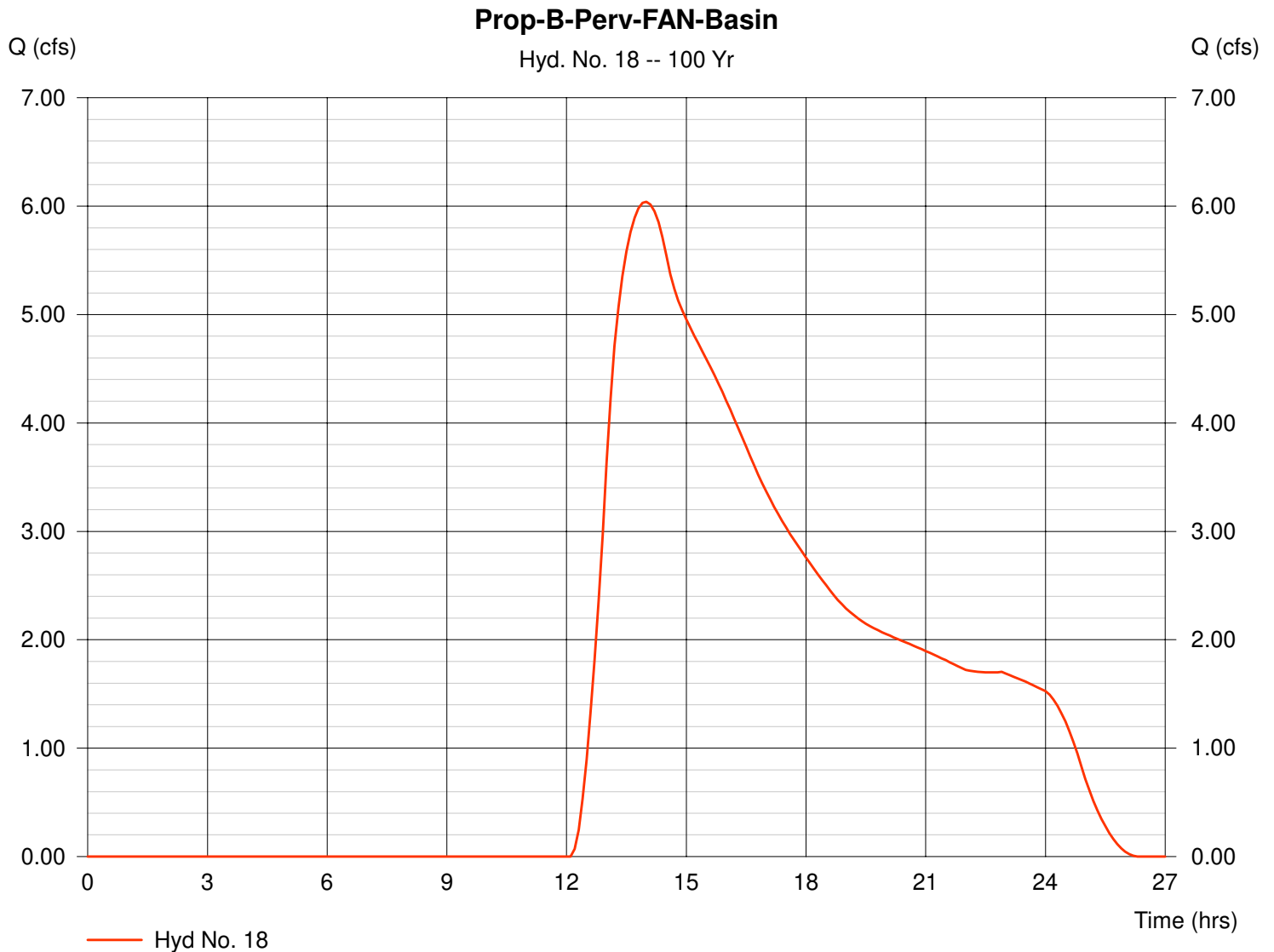

Hydrograph Plot

Hydraflow Hydrographs by Intelisolve

Tuesday, Feb 11 2020, 10:32 AM

Hyd. No. 19

FAN Basin Inflow

Hydrograph type = Combine
Storm frequency = 100 yrs
Inflow hyds. = 17, 18

Peak discharge = 6.84 cfs
Time interval = 6 min

Hydrograph Volume = 148,947 cuft

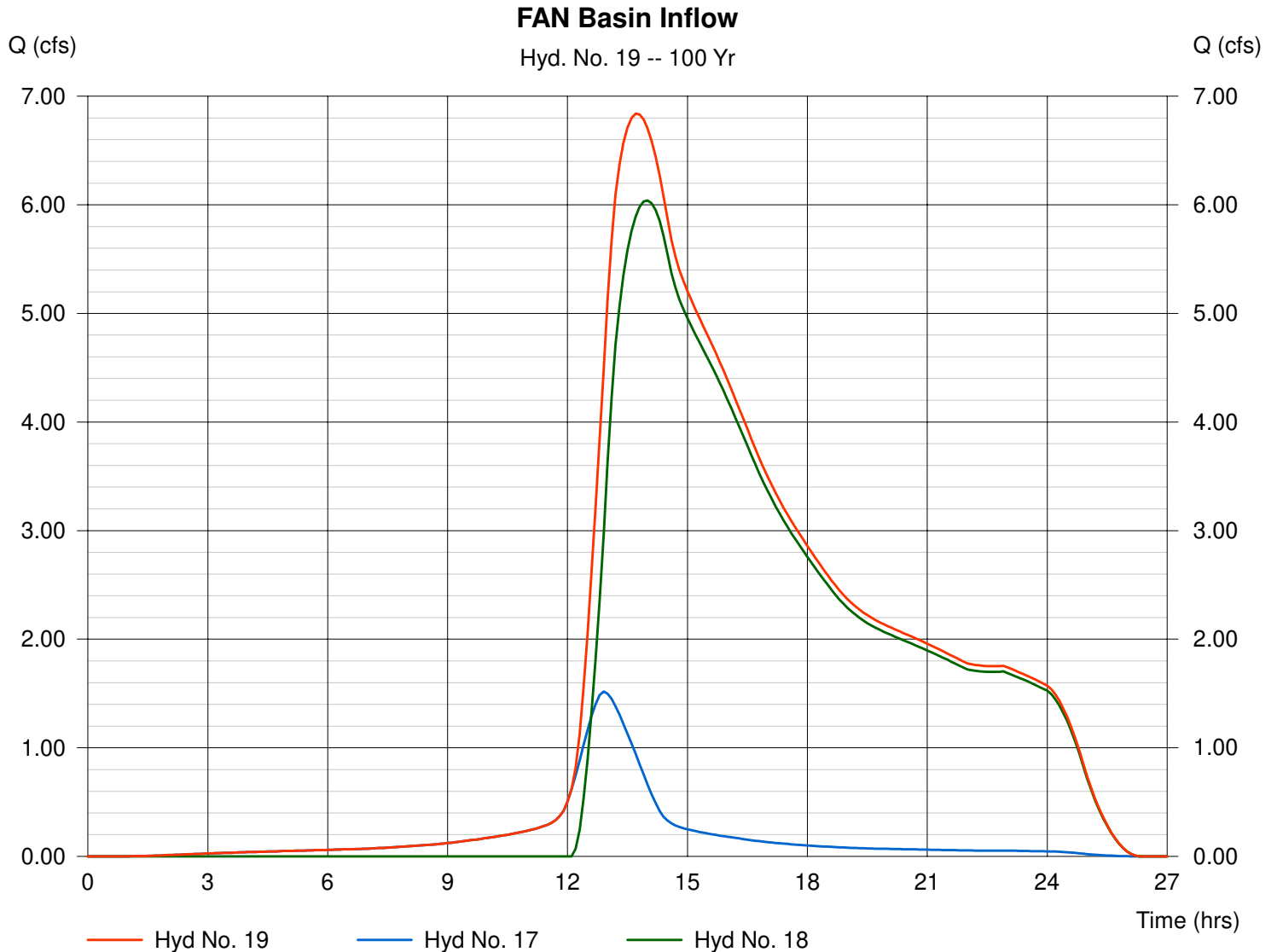

Hydrograph Plot

Hydraflow Hydrographs by Intelisolve

Tuesday, Feb 11 2020, 10:32 AM

Hyd. No. 20

FAN Basin 1 Routing

Hydrograph type = Reservoir
Storm frequency = 100 yrs
Inflow hyd. No. = 19
Reservoir name = FAN Basin

Peak discharge = 2.33 cfs
Time interval = 6 min
Max. Elevation = 156.32 ft
Max. Storage = 80,825 cuft

Storage Indication method used.

Hydrograph Volume = 126,697 cuft

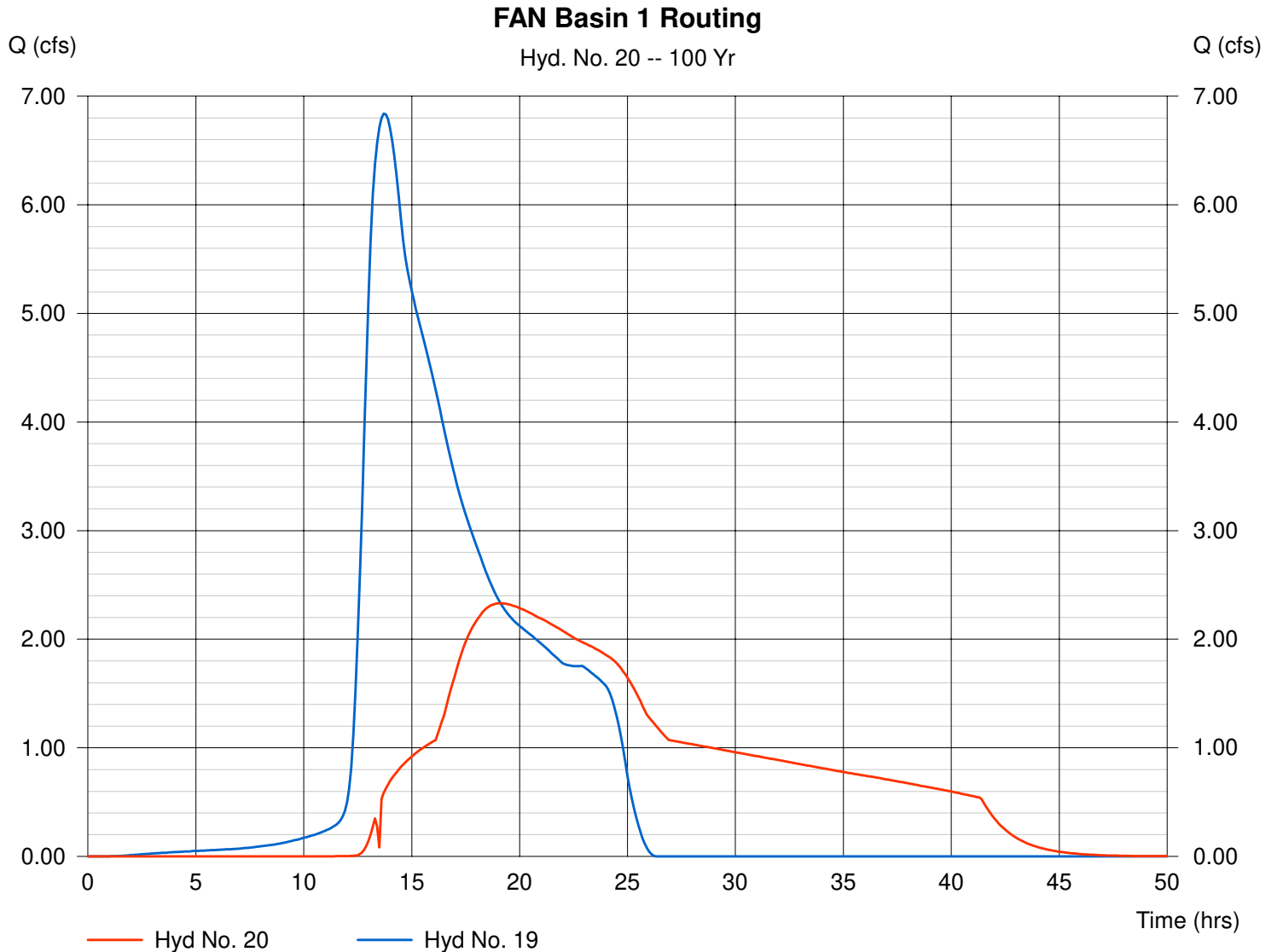

Pond Report

Pond No. 1 - FAN Basin

Pond Data

Pond storage is based on known contour areas. Average end area method used.

Stage / Storage Table

Stage (ft)	Elevation (ft)	Contour area (sqft)	Incr. Storage (cuft)	Total storage (cuft)
0.00	154.25	36,091	0	0
0.75	155.00	38,058	27,806	27,806
1.75	156.00	40,796	39,427	67,233
2.75	157.00	43,656	42,226	109,459

Culvert / Orifice Structures

	[A]	[B]	[C]	[D]
Rise (in)	= 18.00	6.00	0.00	0.00
Span (in)	= 18.00	6.00	0.00	0.00
No. Barrels	= 1	1	0	0
Invert El. (ft)	= 154.25	154.35	0.00	0.00
Length (ft)	= 38.00	0.00	0.00	0.00
Slope (%)	= 3.30	0.00	0.00	0.00
N-Value	= .013	.013	.013	.000
Orif. Coeff.	= 0.60	0.60	0.60	0.00
Multi-Stage	= n/a	Yes	No	No

Weir Structures

	[A]	[B]	[C]	[D]
Crest Len (ft)	= 16.00	2.00	0.00	0.00
Crest El. (ft)	= 156.50	156.00	0.00	0.00
Weir Coeff.	= 3.33	3.33	3.33	0.00
Weir Type	= Riser	Rect	---	---
Multi-Stage	= Yes	Yes	No	No

Exfiltration = 0.000 in/hr (Contour) Tailwater Elev. = 0.00 ft

Note: Culvert/Orifice outflows have been analyzed under inlet and outlet control.

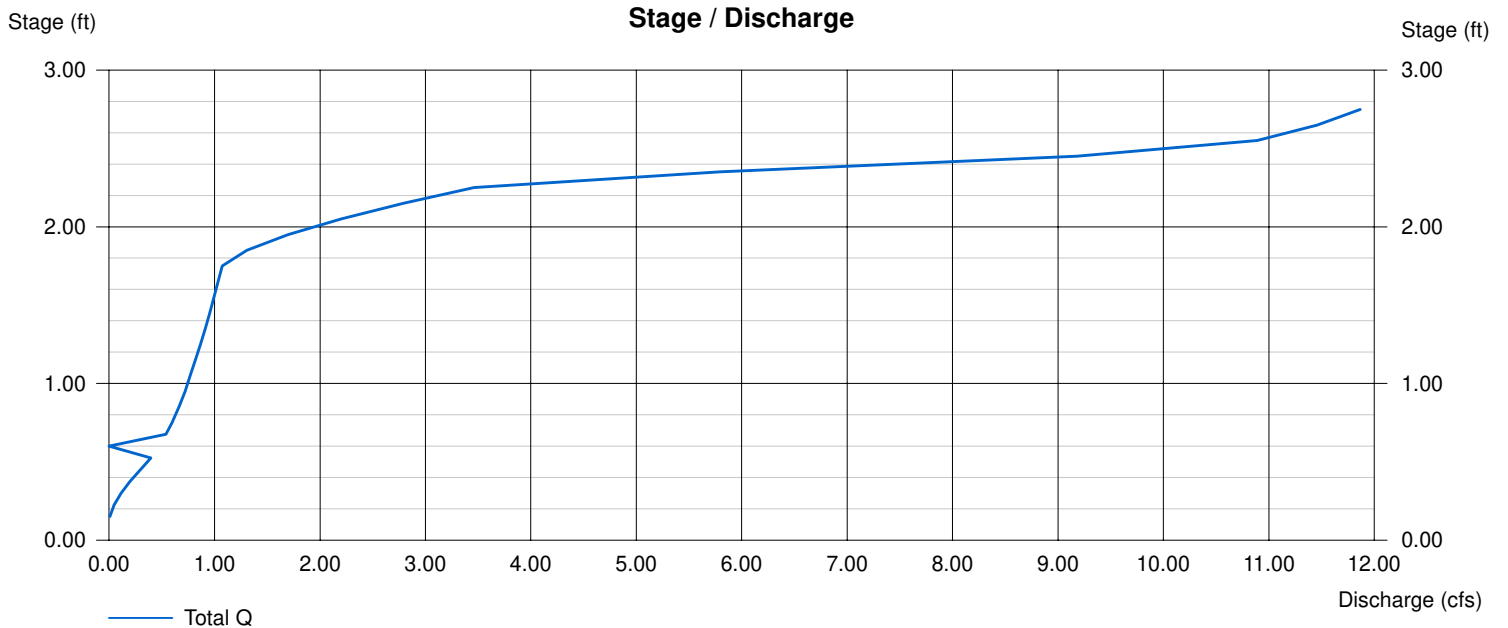

Hydrograph Plot

Hydraflow Hydrographs by Intelisolve

Tuesday, Feb 11 2020, 10:32 AM

Hyd. No. 21

Prop-B-Imp-ROCA-Basin

Hydrograph type = SCS Runoff
Storm frequency = 100 yrs
Drainage area = 0.20 ac
Basin Slope = 0.0 %
Tc method = USER
Total precip. = 7.52 in
Storm duration = 24 hrs

Peak discharge = 0.49 cfs
Time interval = 6 min
Curve number = 98
Hydraulic length = 0 ft
Time of conc. (Tc) = 82.7 min
Distribution = Type III
Shape factor = 484

Hydrograph Volume = 5,286 cuft

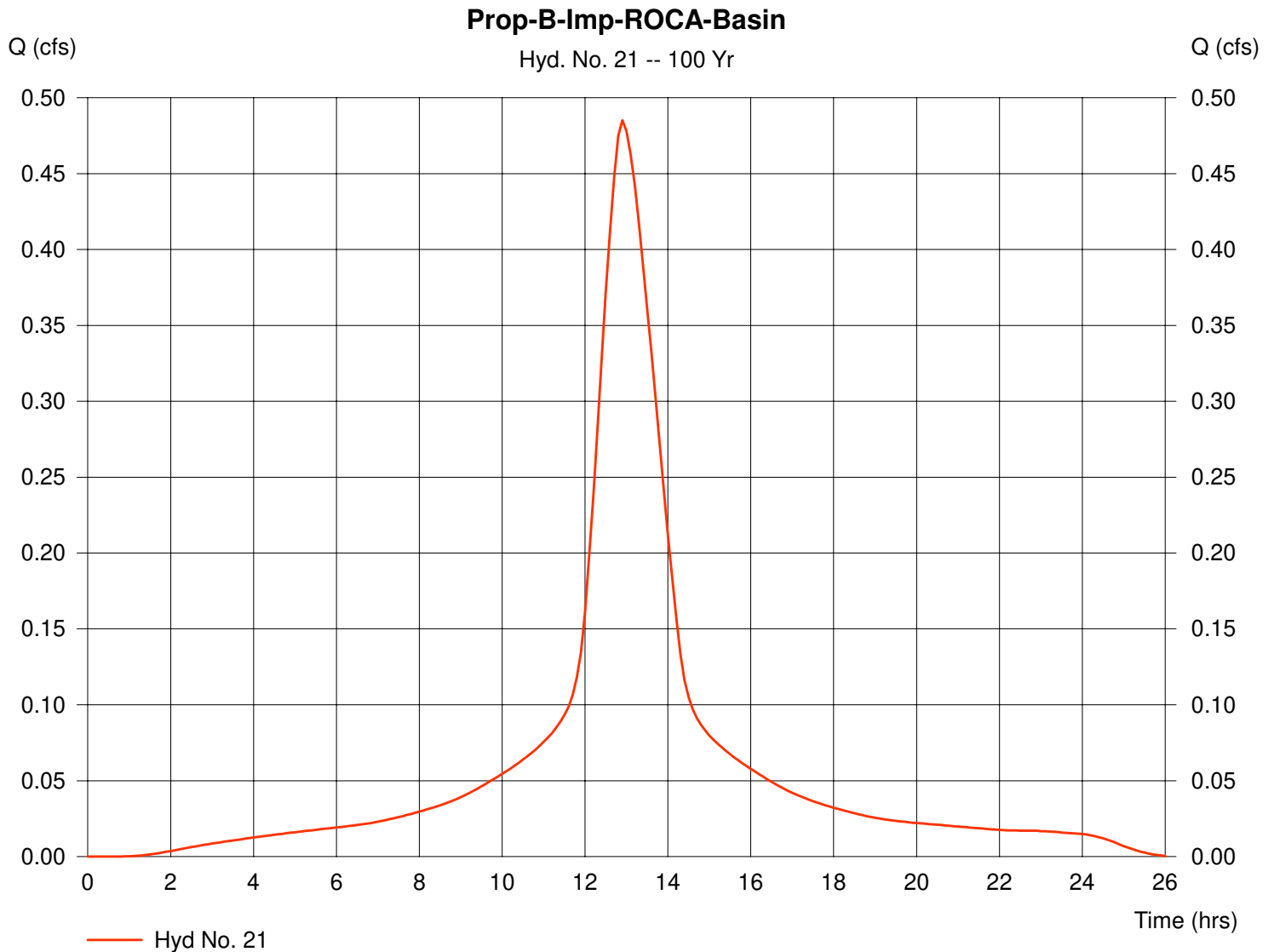

Hydrograph Plot

Hydraflow Hydrographs by Intelisolve

Tuesday, Feb 11 2020, 10:32 AM

Hyd. No. 22

Prop-B-Perv-ROCA-Basin

Hydrograph type = SCS Runoff
Storm frequency = 100 yrs
Drainage area = 10.79 ac
Basin Slope = 0.0 %
Tc method = USER
Total precip. = 7.52 in
Storm duration = 24 hrs

Peak discharge = 2.24 cfs
Time interval = 6 min
Curve number = 38
Hydraulic length = 0 ft
Time of conc. (Tc) = 82.7 min
Distribution = Type III
Shape factor = 484

Hydrograph Volume = 34,456 cuft

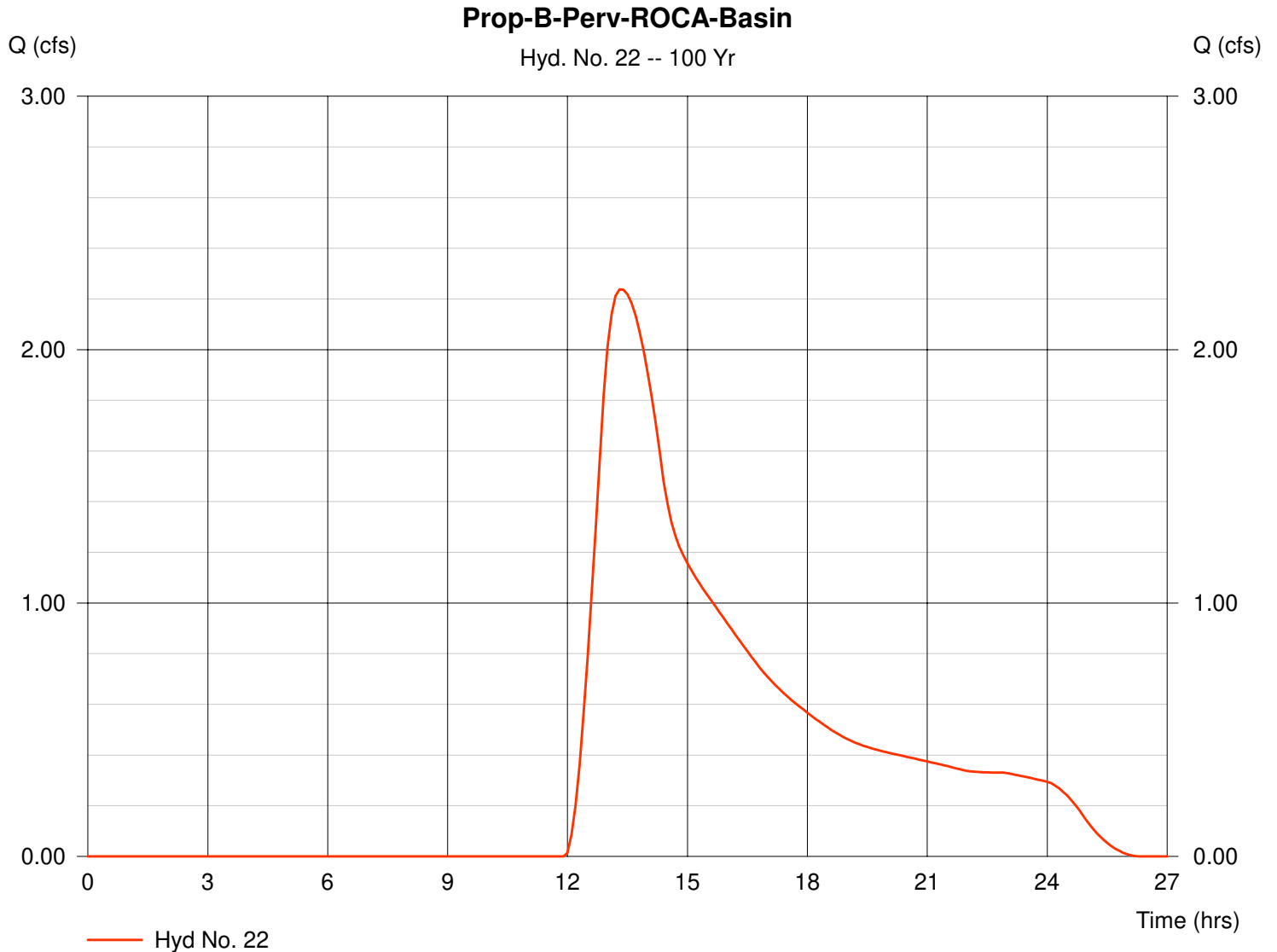

Hydrograph Plot

Hydraflow Hydrographs by Intelisolve

Tuesday, Feb 11 2020, 10:32 AM

Hyd. No. 23

ROCA Basin Inflow

Hydrograph type = Combine
Storm frequency = 100 yrs
Inflow hyds. = 21, 22

Peak discharge = 2.65 cfs
Time interval = 6 min

Hydrograph Volume = 39,741 cuft

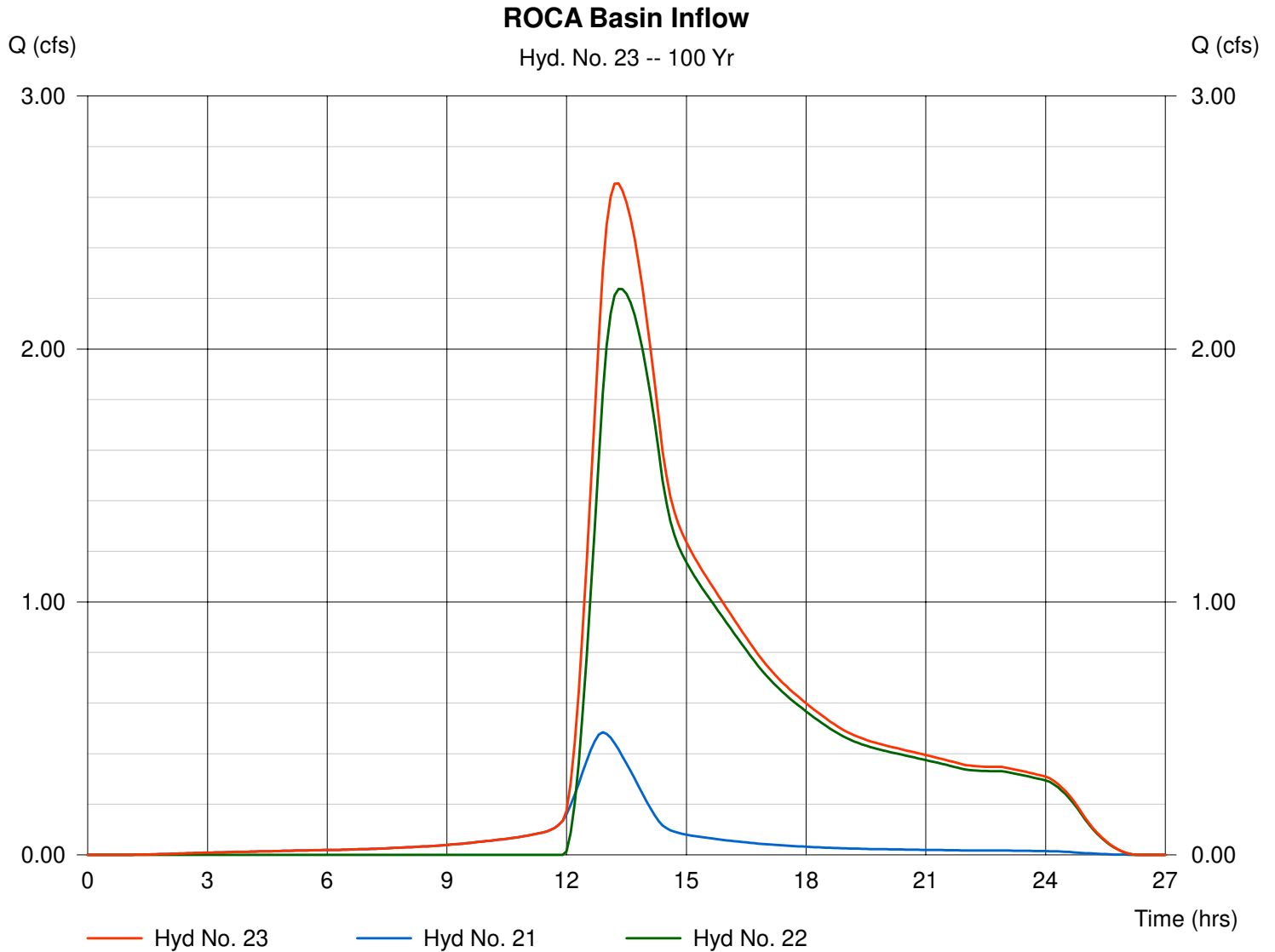

Hydrograph Plot

Hydraflow Hydrographs by Intelisolve

Tuesday, Feb 11 2020, 10:32 AM

Hyd. No. 24

ROCA Basin Routing

Hydrograph type = Reservoir
Storm frequency = 100 yrs
Inflow hyd. No. = 23
Reservoir name = ROCA Basin

Peak discharge = 0.91 cfs
Time interval = 6 min
Max. Elevation = 155.85 ft
Max. Storage = 15,477 cuft

Storage Indication method used.

Hydrograph Volume = 38,614 cuft

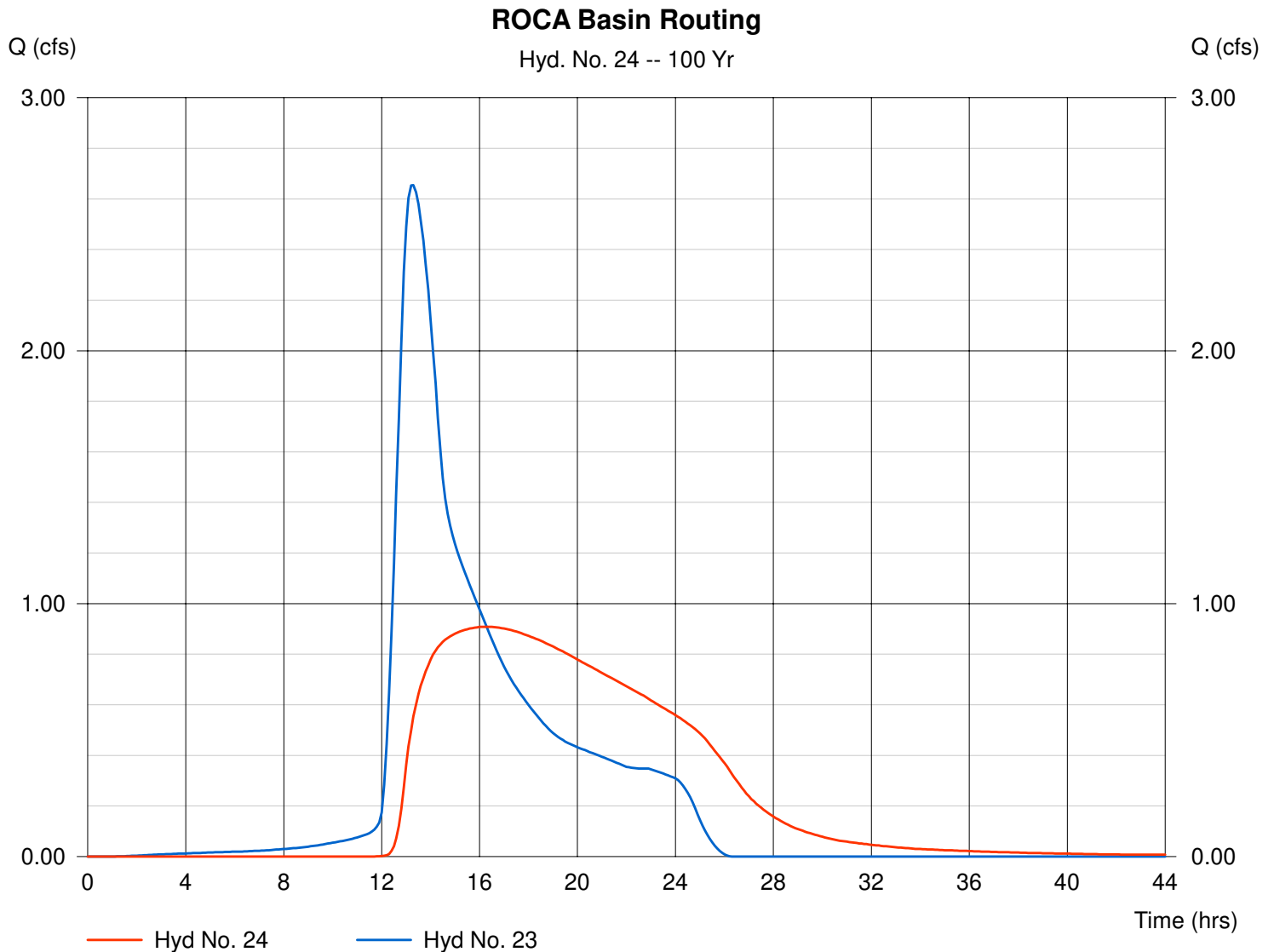

Pond Report

Hydraflow Hydrographs by Intelisolve

Tuesday, Feb 11 2020, 10:32 AM

Pond No. 2 - ROCA Basin

Pond Data

Pond storage is based on known contour areas. Average end area method used.

Stage / Storage Table

Stage (ft)	Elevation (ft)	Contour area (sqft)	Incr. Storage (cuft)	Total storage (cuft)
0.00	154.50	10,126	0	0
0.50	155.00	11,053	5,295	5,295
1.50	156.00	13,036	12,045	17,339
2.00	156.50	14,055	6,773	24,112

Culvert / Orifice Structures

	[A]	[B]	[C]	[D]
Rise (in)	= 18.00	6.00	0.00	0.00
Span (in)	= 18.00	6.00	0.00	0.00
No. Barrels	= 1	1	0	0
Invert El. (ft)	= 154.50	154.60	0.00	0.00
Length (ft)	= 115.00	0.00	0.00	0.00
Slope (%)	= 1.30	0.00	0.00	0.00
N-Value	= .013	.013	.000	.000
Orif. Coeff.	= 0.60	0.60	0.00	0.00
Multi-Stage	= n/a	Yes	No	No

Weir Structures

	[A]	[B]	[C]	[D]
Crest Len (ft)	= 16.00	0.00	0.00	0.00
Crest El. (ft)	= 156.50	0.00	0.00	0.00
Weir Coeff.	= 3.33	3.33	0.00	0.00
Weir Type	= Riser	---	---	---
Multi-Stage	= Yes	No	No	No

Exfiltration = 0.000 in/hr (Contour) Tailwater Elev. = 0.00 ft

Note: Culvert/Orifice outflows have been analyzed under inlet and outlet control.

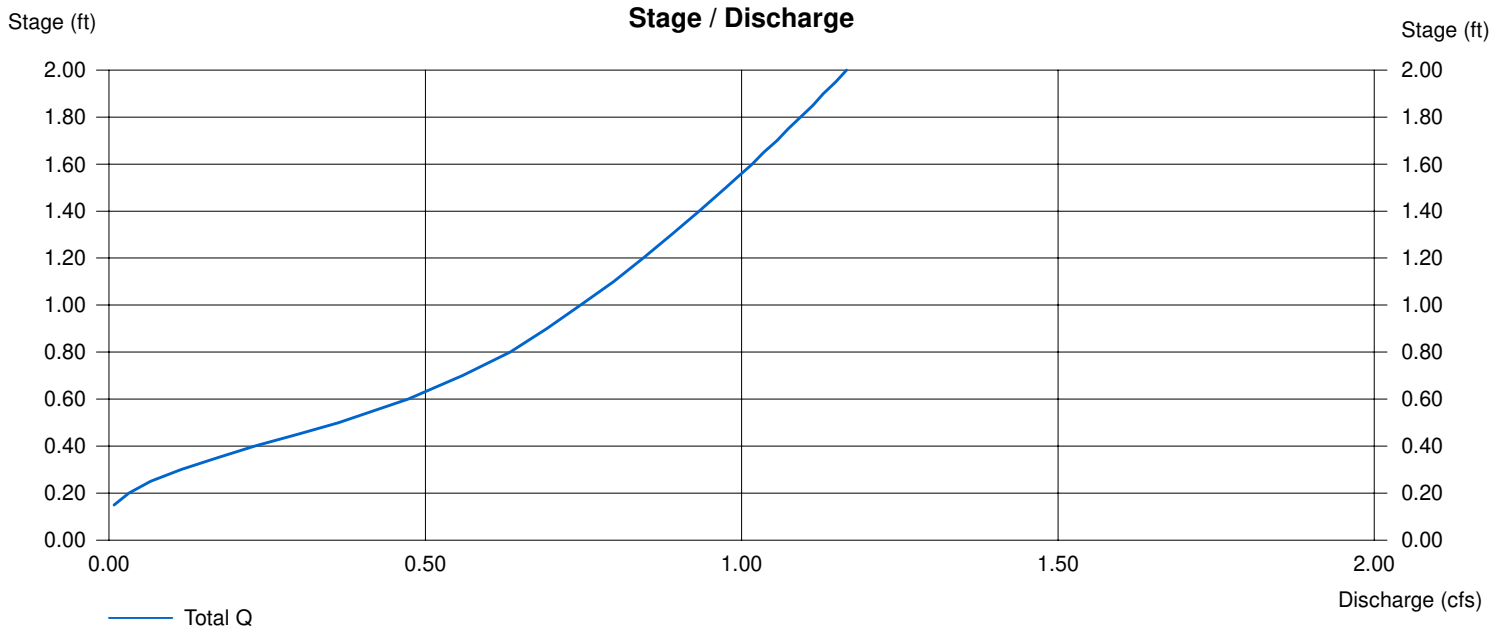

Hydrograph Plot

Hydraflow Hydrographs by Intelisolve

Tuesday, Feb 11 2020, 10:32 AM

Hyd. No. 25

Prop-B

Hydrograph type = Combine
Storm frequency = 100 yrs
Inflow hyds. = 14, 15

Peak discharge = 2.31 cfs
Time interval = 6 min

Hydrograph Volume = 54,981 cuft

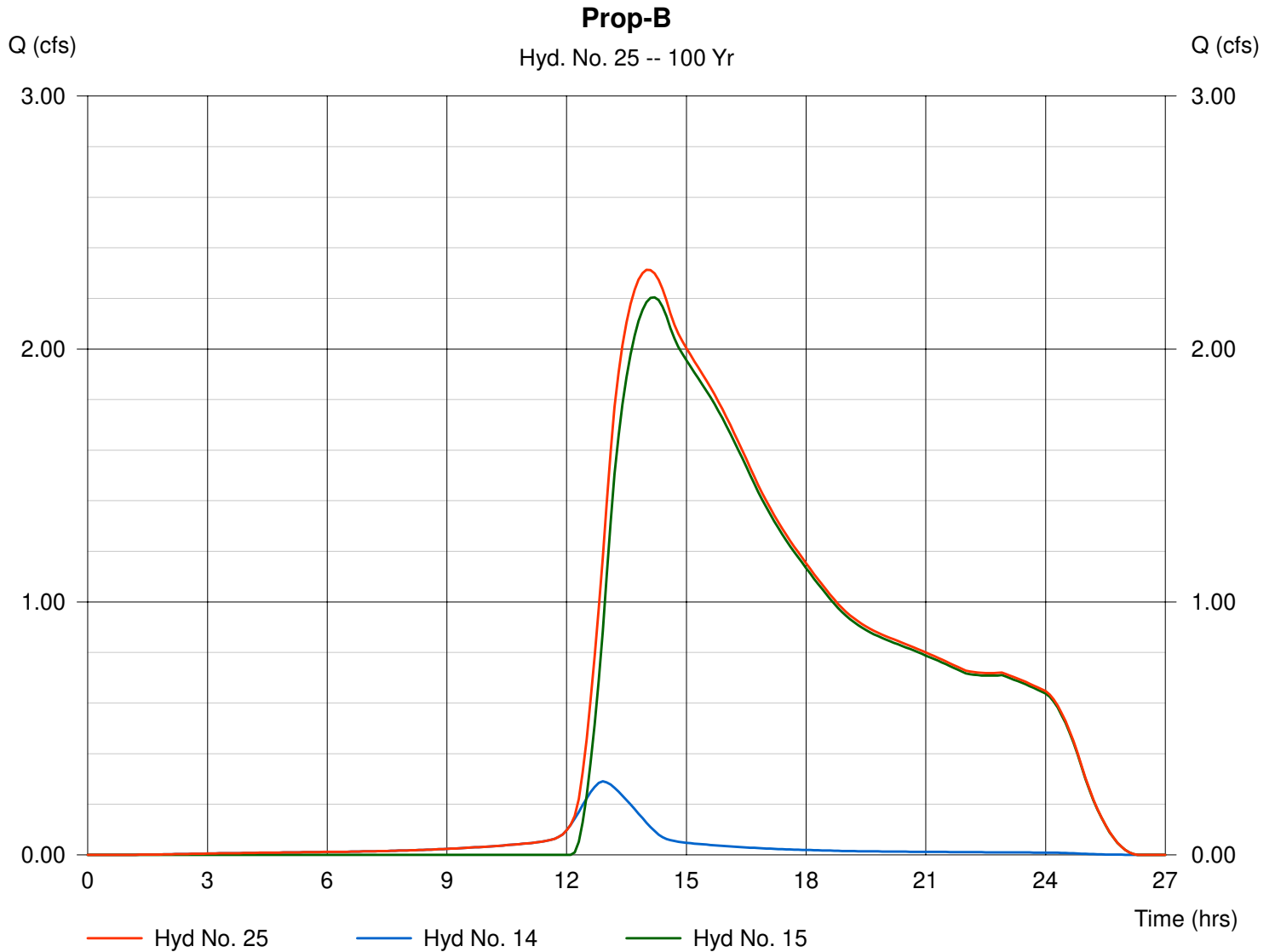

Hydrograph Plot

Hydraflow Hydrographs by Intelisolve

Tuesday, Feb 11 2020, 10:32 AM

Hyd. No. 26

Prop-B

Hydrograph type = Combine
Storm frequency = 100 yrs
Inflow hyds. = 20, 24, 25

Peak discharge = 4.20 cfs
Time interval = 6 min

Hydrograph Volume = 220,292 cuft

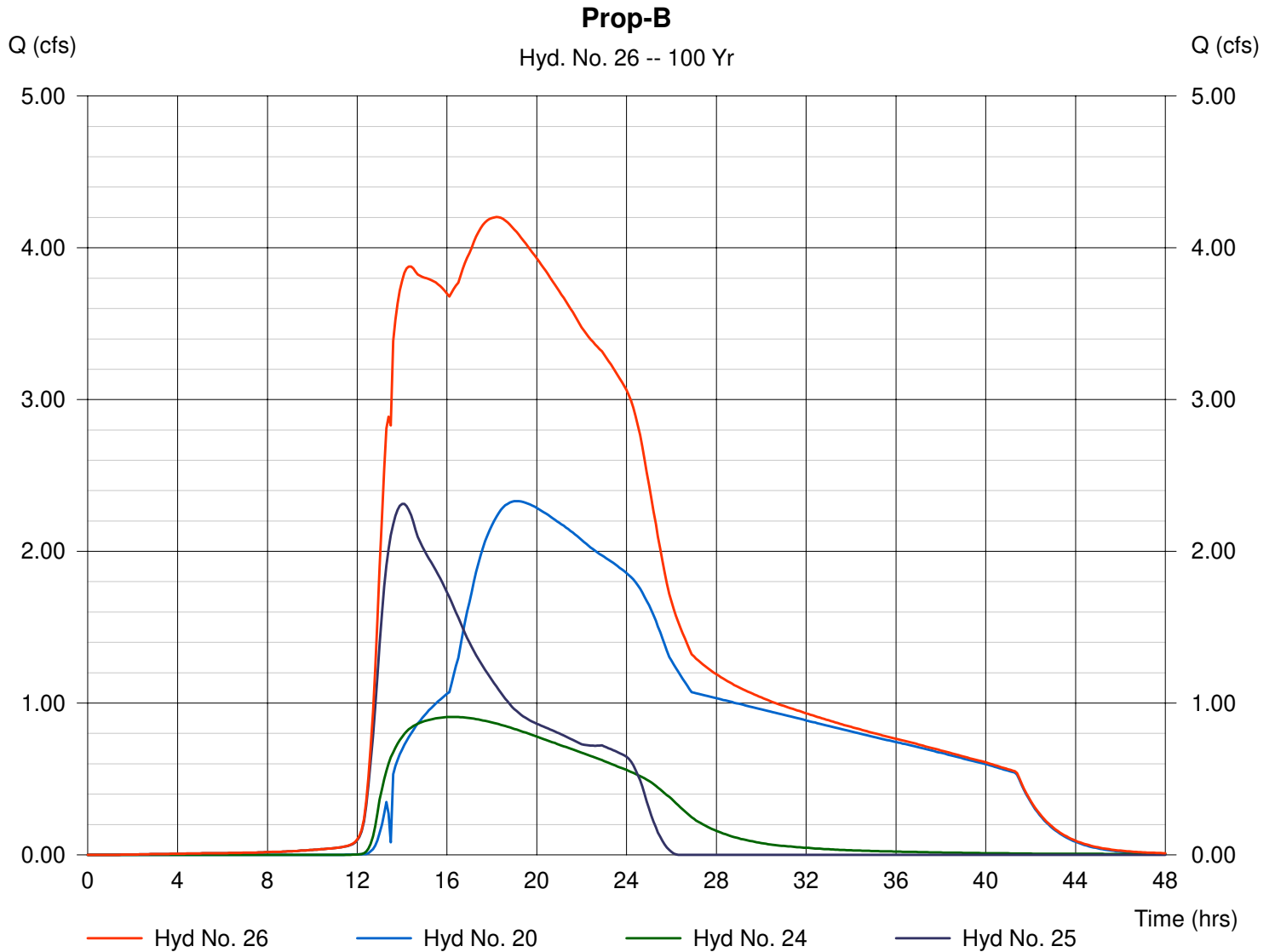

Hydrograph Plot

Hydraflow Hydrographs by Intelisolve

Tuesday, Feb 11 2020, 10:32 AM

Hyd. No. 29

Exist-C-Imp

Hydrograph type = SCS Runoff
 Storm frequency = 100 yrs
 Drainage area = 1.66 ac
 Basin Slope = 0.0 %
 Tc method = USER
 Total precip. = 7.52 in
 Storm duration = 24 hrs

Peak discharge = 4.31 cfs
 Time interval = 6 min
 Curve number = 98
 Hydraulic length = 0 ft
 Time of conc. (Tc) = 76.33 min
 Distribution = Type III
 Shape factor = 484

Hydrograph Volume = 43,185 cuft

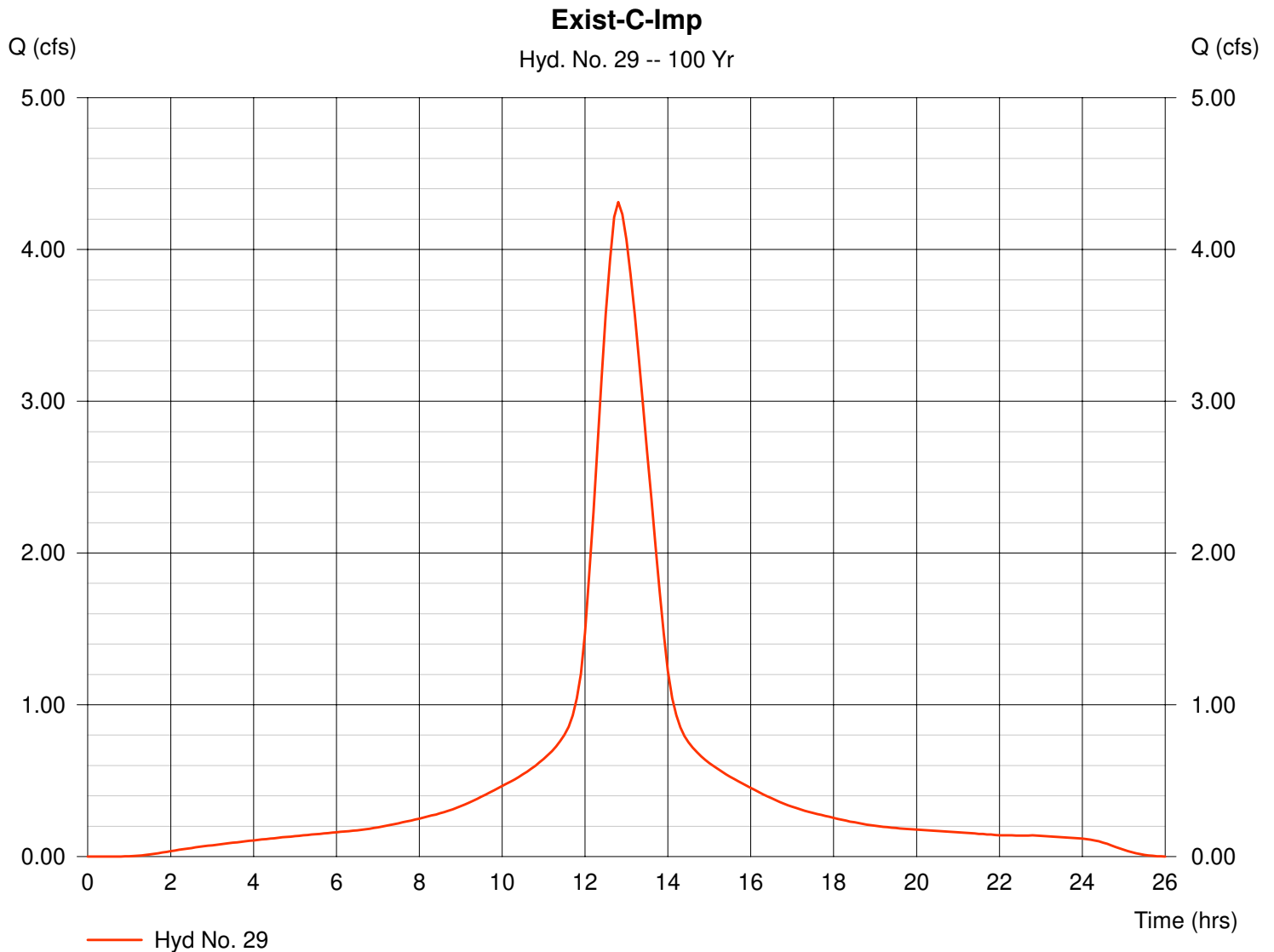

Hydrograph Plot

Hydraflow Hydrographs by Intelisolve

Tuesday, Feb 11 2020, 10:32 AM

Hyd. No. 30

Exist-C-Perv

Hydrograph type = SCS Runoff
Storm frequency = 100 yrs
Drainage area = 130.63 ac
Basin Slope = 0.0 %
Tc method = USER
Total precip. = 7.52 in
Storm duration = 24 hrs

Peak discharge = 37.55 cfs
Time interval = 6 min
Curve number = 40
Hydraulic length = 0 ft
Time of conc. (Tc) = 76.33 min
Distribution = Type III
Shape factor = 484

Hydrograph Volume = 488,040 cuft

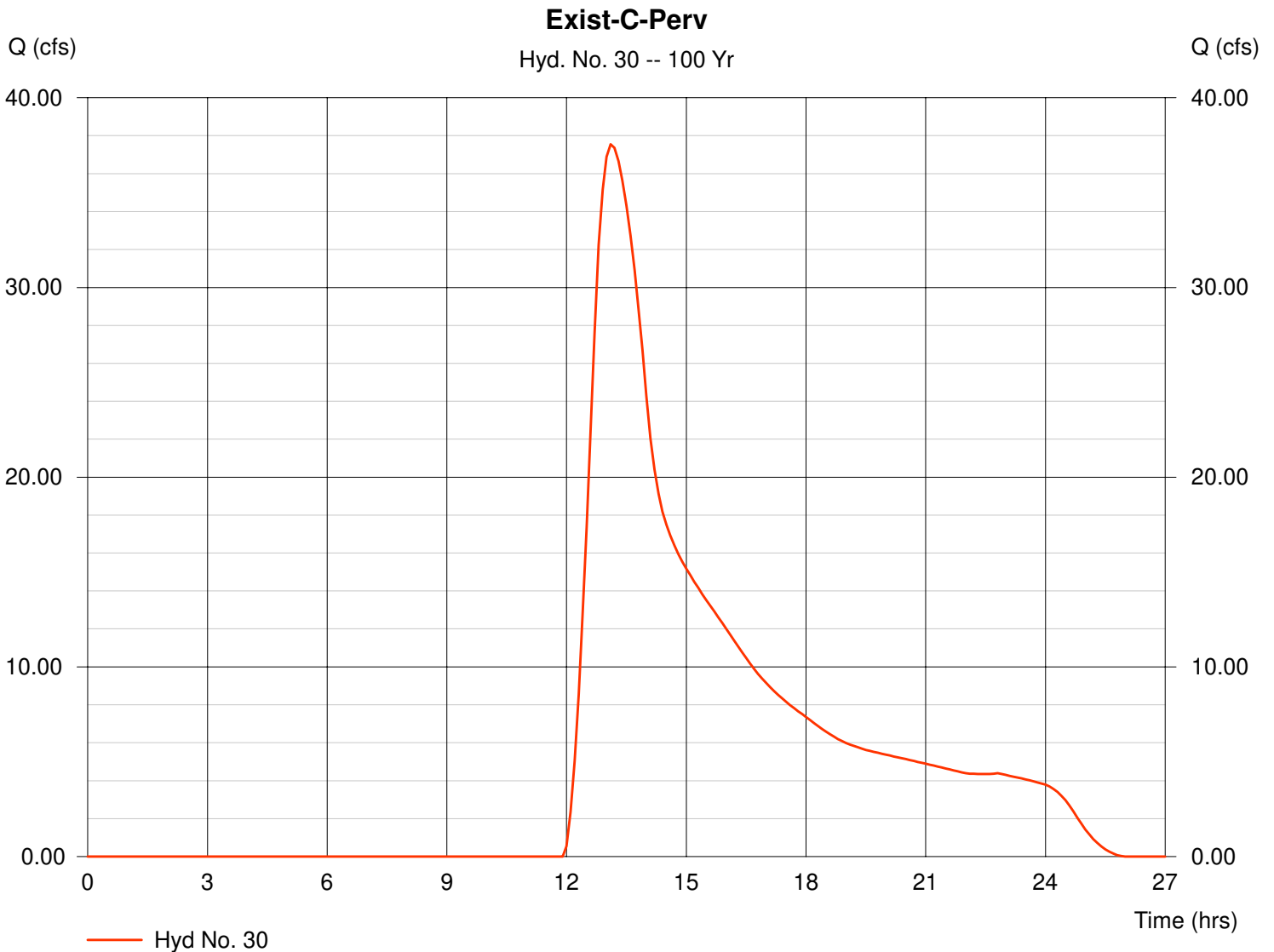

Hydrograph Plot

Hydraflow Hydrographs by Intelisolve

Tuesday, Feb 11 2020, 10:32 AM

Hyd. No. 31

Exist-C

Hydrograph type = Combine
Storm frequency = 100 yrs
Inflow hyds. = 29, 30

Peak discharge = 41.38 cfs
Time interval = 6 min

Hydrograph Volume = 531,225 cuft

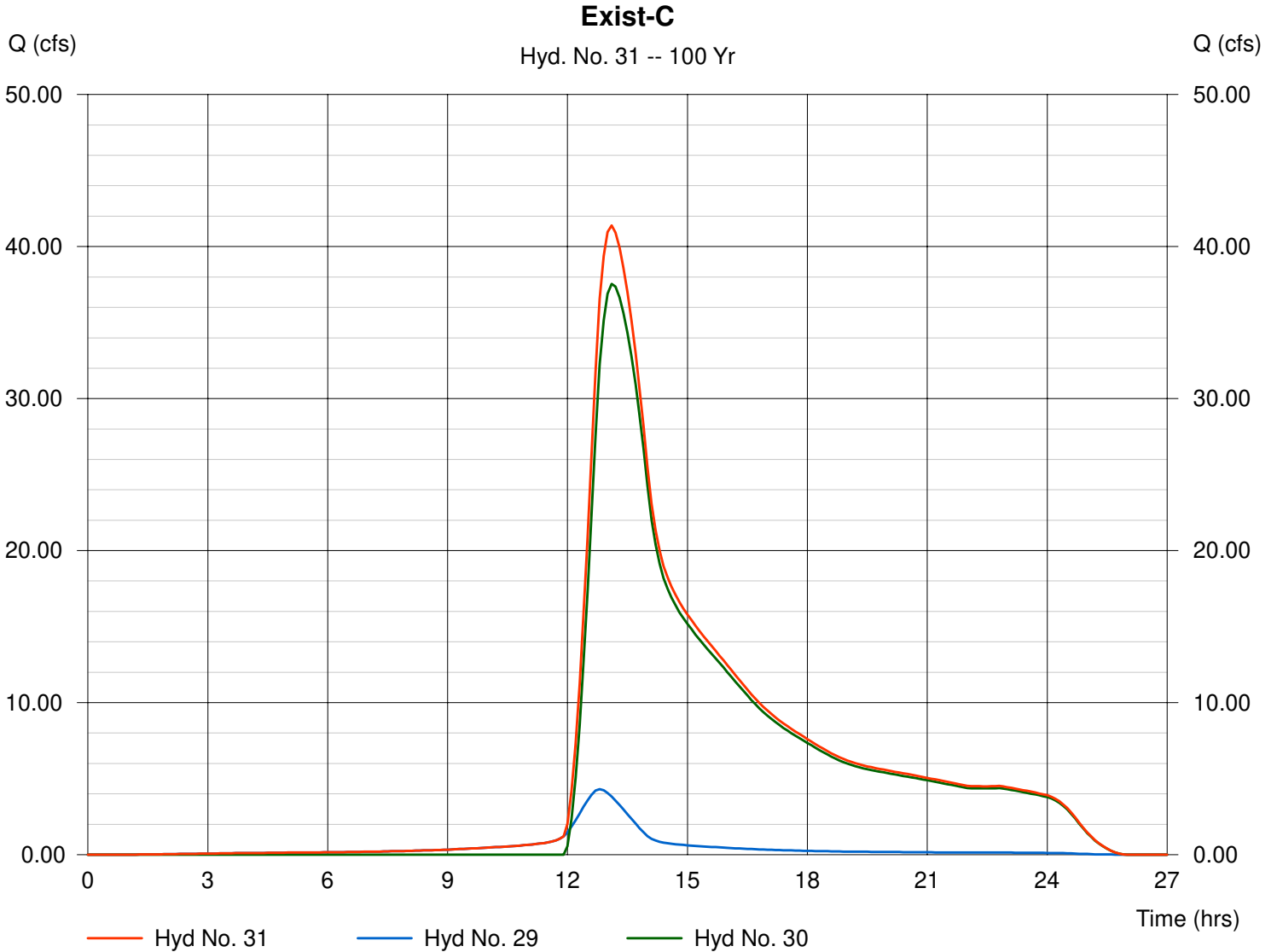

Hydrograph Plot

Hydraflow Hydrographs by Intelisolve

Tuesday, Feb 11 2020, 10:32 AM

Hyd. No. 33

Prop-C-Imp

Hydrograph type = SCS Runoff
 Storm frequency = 100 yrs
 Drainage area = 1.42 ac
 Basin Slope = 0.0 %
 Tc method = USER
 Total precip. = 7.52 in
 Storm duration = 24 hrs

Peak discharge = 3.69 cfs
 Time interval = 6 min
 Curve number = 98
 Hydraulic length = 0 ft
 Time of conc. (Tc) = 75.49 min
 Distribution = Type III
 Shape factor = 484

Hydrograph Volume = 36,942 cuft

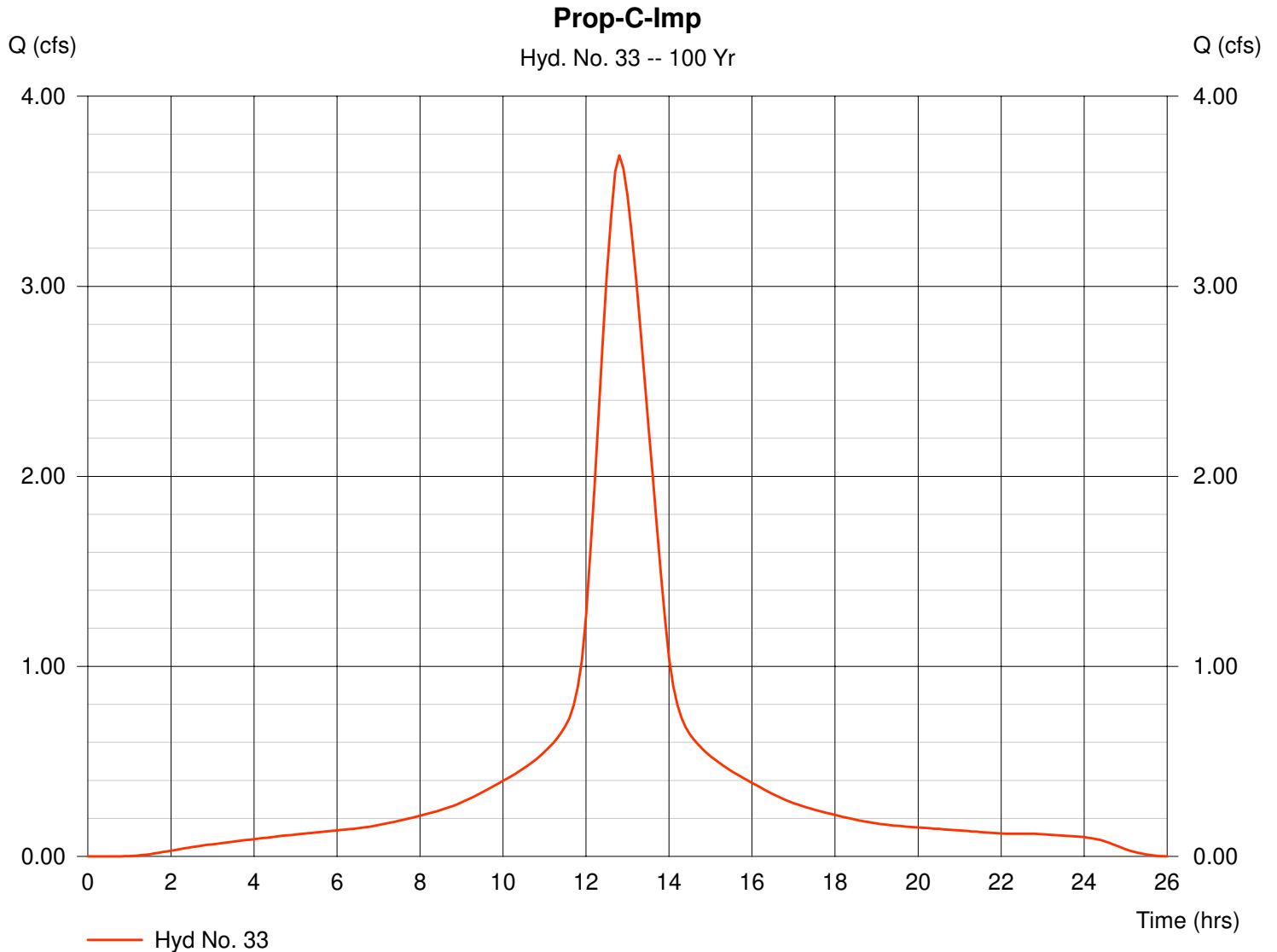

Hydrograph Plot

Hydraflow Hydrographs by Intelisolve

Tuesday, Feb 11 2020, 10:32 AM

Hyd. No. 34

Prop-C-Perv

Hydrograph type = SCS Runoff
 Storm frequency = 100 yrs
 Drainage area = 133.04 ac
 Basin Slope = 0.0 %
 Tc method = USER
 Total precip. = 7.52 in
 Storm duration = 24 hrs

Peak discharge = 38.24 cfs
 Time interval = 6 min
 Curve number = 40
 Hydraulic length = 0 ft
 Time of conc. (Tc) = 75.49 min
 Distribution = Type III
 Shape factor = 484

Hydrograph Volume = 497,044 cuft

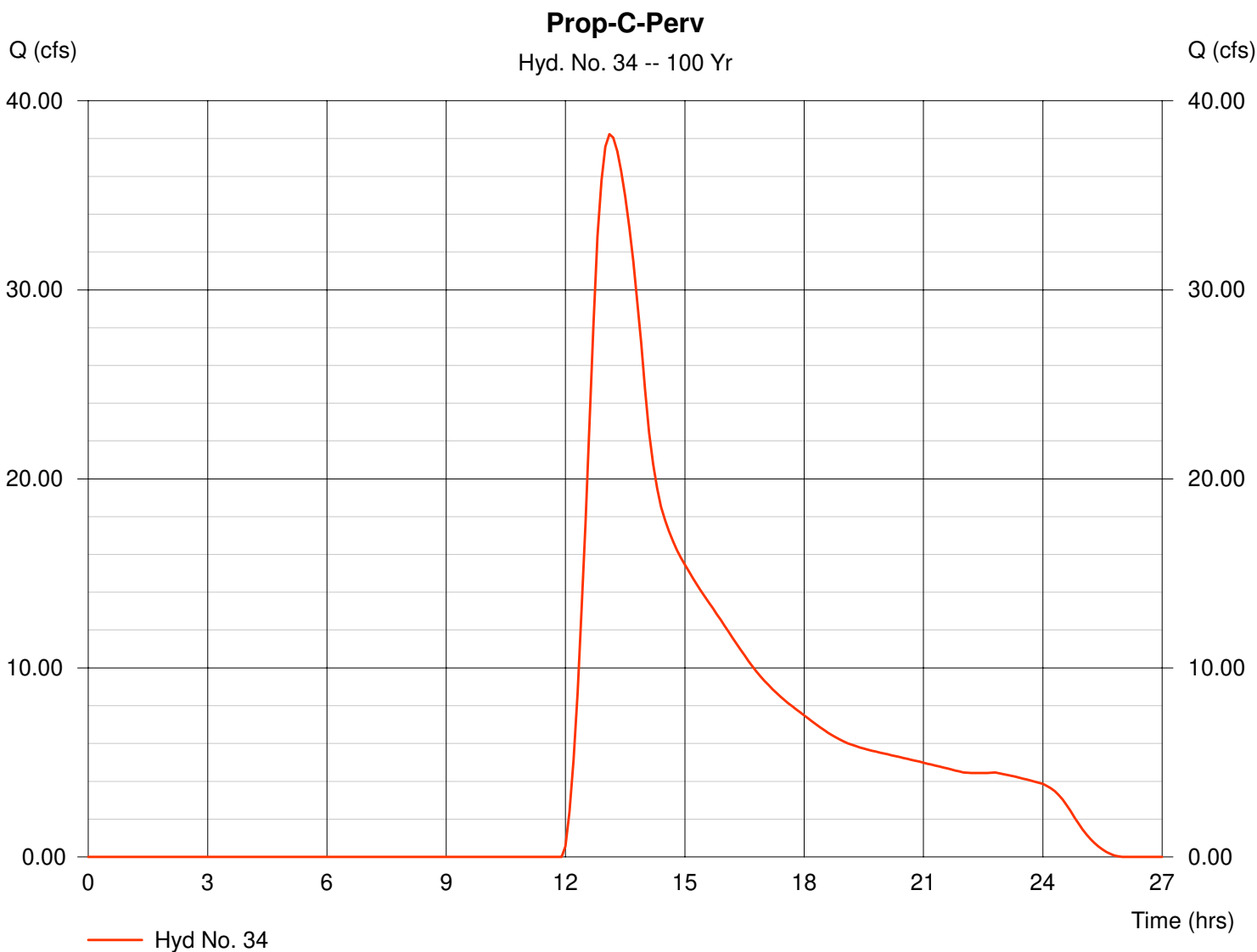

Hydrograph Plot

Hydraflow Hydrographs by Intelisolve

Tuesday, Feb 11 2020, 10:32 AM

Hyd. No. 35

Prop-C

Hydrograph type = Combine
Storm frequency = 100 yrs
Inflow hyds. = 33, 34

Peak discharge = 41.52 cfs
Time interval = 6 min

Hydrograph Volume = 533,986 cuft

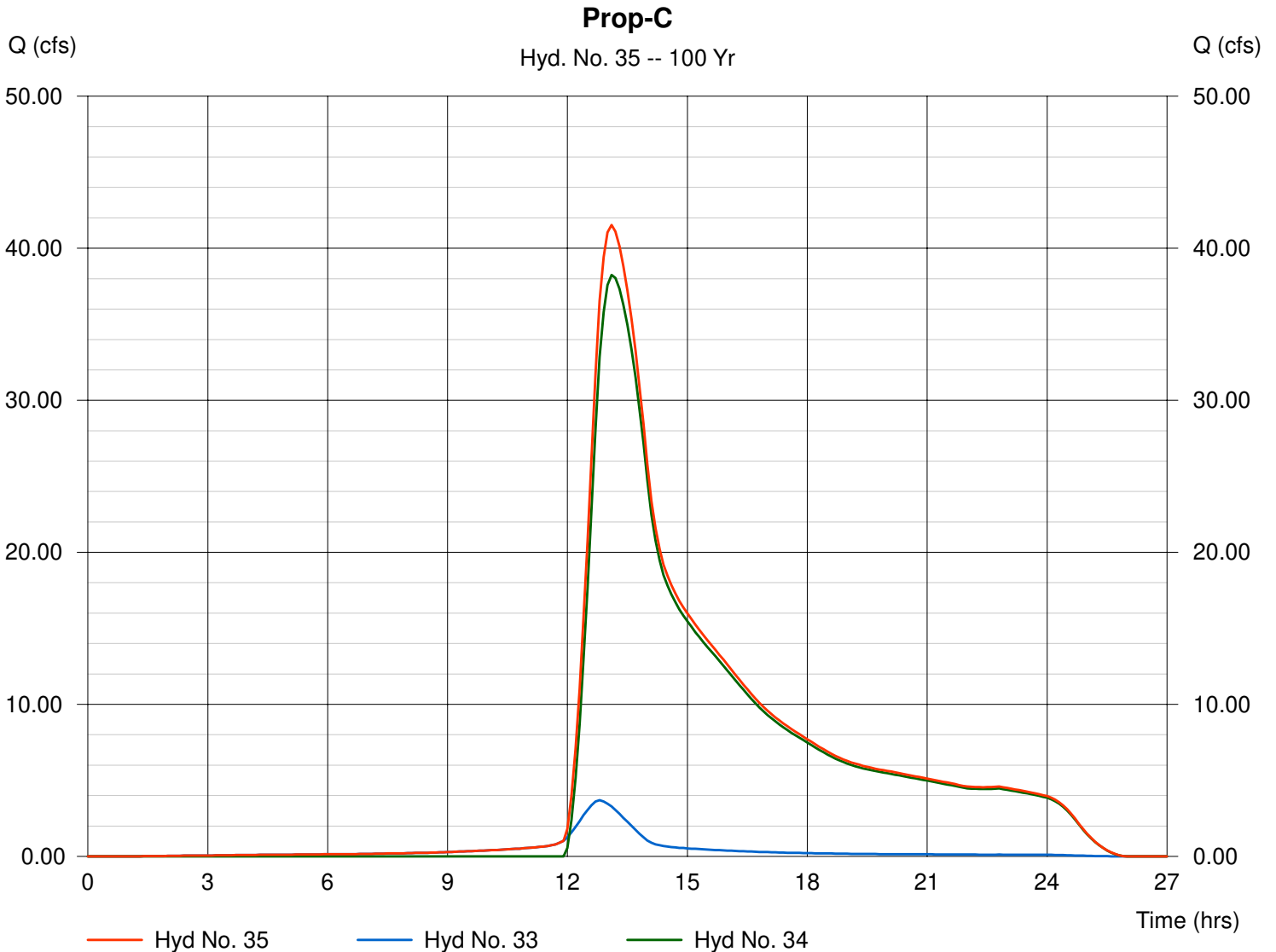

Appendix E Existing and Proposed Drainage Area Maps

P:\MASS_DS\BMA_ARNG_CE_GUN_RANGE\500_CADD_GIS\GRAPHICS\10_CADD\CIVIL\WORKING\MA_ARNG_CAMP_EDWARDS - EX DRAINAGE AREAS.DWG Aug 20, 2019 - 4:54 PM Plotted By: BURNEIMER, DENNIS

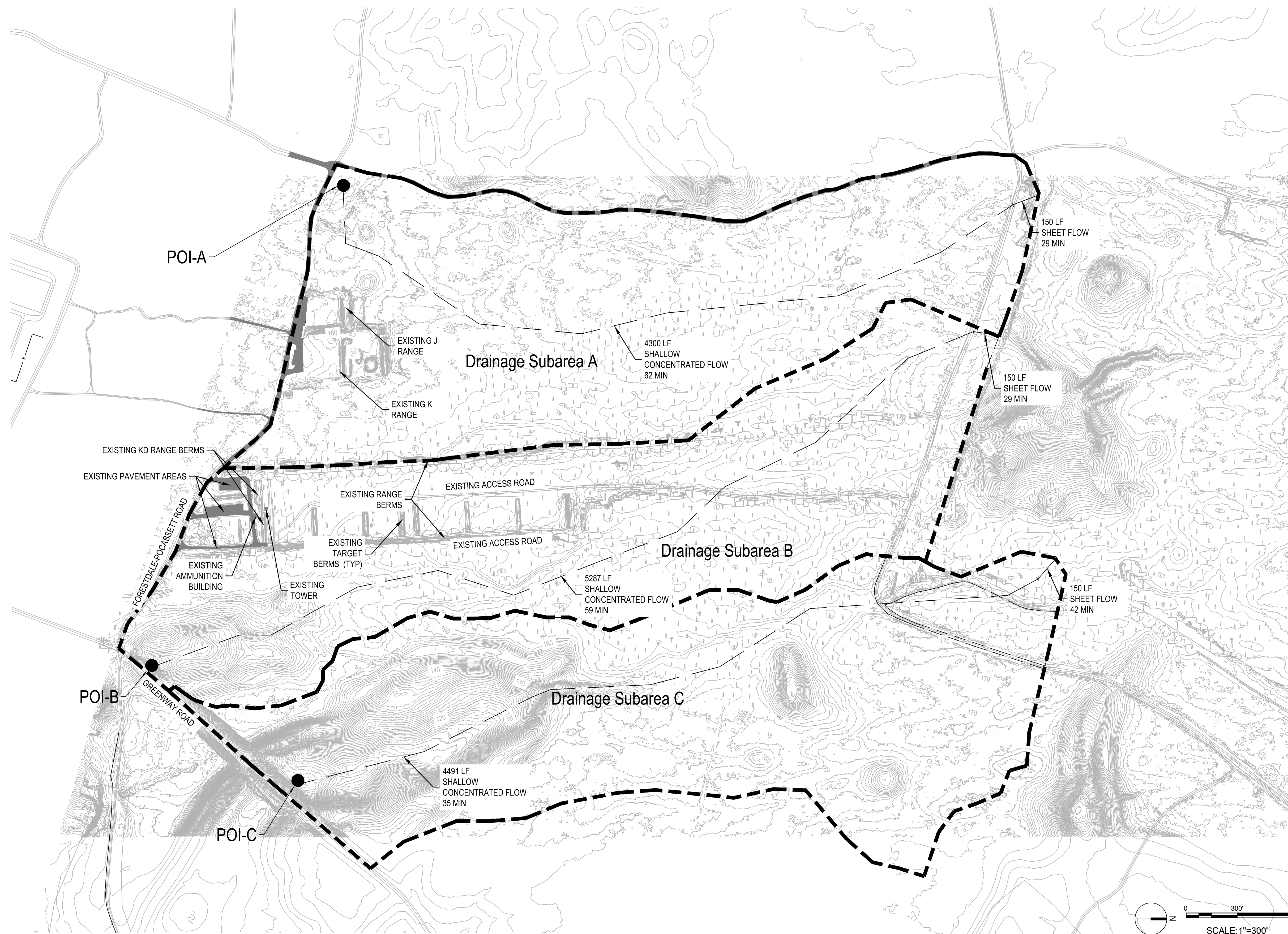

LEGEND
 ■ EXISTING IMPERVIOUS AREA
 □ EXISTING WOODED AREA

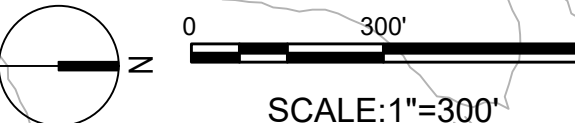

DATE	REVISION MADE	BY	AUTHORIZED

AUTOMATED MULTIPURPOSE MACHINE GUN RANGE (MPMG)			
EXISTING DRAINAGE AREA MAPPING			
DATE:	DES BY:	BAKER PROJECT NUMBER	SHEET NO.
SCALE:	DWN BY:	170789	DA-1
SIZE: ANSI D	CHK BY:	GOV. PROJECT NUMBER	250194FY19
FILE: MA ARNG CAMP EDWARDS - EX DRAINAGE AREAS	DWG	250194FY19	1 OF 1



MICHAEL BAKER INTERNATIONAL
 125 CAMBRIDGE PARK DRIVE, SUITE 502
 CAMBRIDGE, MASSACHUSETTS 02140

AUTOMATED MULTIPURPOSE MACHINE GUN RANGE (MPMG)
 CAMP EDWARDS JOINT BASE CAPE COD
 BOURNE, MASSACHUSETTS



P:\MASS_DS\BMA_ARNG\CE_GUN_RANGE\500_CADD_GIS\GRAPHICS\10_CADD\CIVIL\WORKING\MA_ARNG_CAMP_EDWARDS - PROP DRAINAGE AREA\SCN.DWG Nov 27, 2019 - 11:19 AM Plotted By: MAKER, KATHARINE



POST DEVELOPMENT SITE CONDITIONS

	Parking Area/ Driveways/Buildings		Gravel		Wooded		Pervious Area (Previously cleared)		Total Area	
	SF	AC	SF	AC	SF	AC	SF	AC	SF	AC
Drainage Area A	160,555	3.7	0.0	0.0	4,086,626	93.8	1,471,461	33.8	5,718,642	131.3
Drainage Area B	3991	0.1	370,581	8.5	1,540,482	35.4	3,920,102	90.0	5,835,156	134.0
Drainage Area C	0	0.0	0.0	0.0	4,780,965	109.8	1,076,274	24.7	5,857,239	134.5

- LEGEND**
- PROPOSED IMPERVIOUS AREA
 - EXISTING WOODED AREA (TO REMAIN)
 - PROPOSED GRAVEL AREA

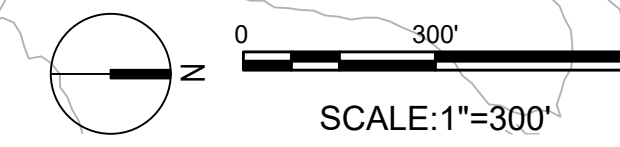

DATE	REVISION MADE	BY	AUTHORIZED
------	---------------	----	------------

AUTOMATED MULTIPURPOSE MACHINE GUN RANGE (MPMG)			
PROPOSED DRAINAGE AREA MAPPING			
DATE:	DES BY:	BAKER PROJECT NUMBER	SHEET NO.
SCALE:	DWN BY:	170789	DA-2
SIZE: ANSI D	CHK BY:	GOV. PROJECT NUMBER	
FILE: MA_ARNG_CAMP_EDWARDS - PROP DRAINAGE ARE	SCN.DWG	250194FY19	1 OF 1



MICHAEL BAKER INTERNATIONAL
125 CAMBRIDGE PARK DRIVE, SUITE 502
CAMBRIDGE, MASSACHUSETTS 02140

AUTOMATED MULTIPURPOSE MACHINE GUN RANGE (MPMG)
CAMP EDWARDS JOINT BASE CAPE COD
BOURNE, MASSACHUSETTS

