

70506-69

9/7/2010

1041



UNITED STATES ENVIRONMENTAL PROTECTION AGENCY
WASHINGTON, D.C. 20460

OFFICE OF CHEMICAL SAFETY
AND POLLUTION PREVENTION

SEP - 7 2010

Diane Fago
United Phosphorus, Inc.
630 Freedom Business Center, Suite 402
King of Prussia, PA 19406

Subject: Revised Label to Comply With Risk Mitigation
QuickPhlo-R Granules
EPA Reg. No. 70506-69
Your Application Dated August 26, 2010

Dear Ms. Fago,

The label referred to above, submitted in connection with the registration under the Federal Insecticide, Fungicide, and Rodenticide Act (FIFRA), as amended, is acceptable with the following changes:

- On page one of the Applicator's Manual, revise THCOMPLETE..." to read "THE COMPLETE..."
- On page 3 of the container label, under DIRECTIONS FOR USE, delete "1.2.3.4."
- On page 15 of the Applicator's Manual, revise "9.1 MAZIMUM..." to read "9.1 MAXIMUM..."

A stamped copy is enclosed for your records. Please submit on copy of the final printed label before releasing the product for shipment. If you have questions, email Joanne Edwards at edwards.joanne@epa.gov or by telephone at (703) 305-6736.

Sincerely yours,

A handwritten signature in black ink that reads "Venus Eagle".

Venus Eagle, Product Manager 1
Insecticide-Rodenticide Branch
Registration Division (7505P)

20941

[CENTER PANEL]

RESTRICTED USE PESTICIDE
DUE TO ACUTE INHALATION TOXICITY OF PHOSPHINE GAS

For retail sale to Dealers and Certified Applicators only. For use by Certified Applicators or persons under their direct supervision, and only for those uses covered by the Certified Applicator's certification. Refer to the directions in the Applicator's Manual for requirements of the physical presence of a Certified Applicator.

THE COMPLETE LABEL FOR THIS PRODUCT CONSISTS OF THE CONTAINER LABEL AND APPLICATOR'S MANUAL WHICH MUST ACCOMPANY THE PRODUCT. READ AND UNDERSTAND THE ENTIRE LABELING AND APPLICATOR'S MANUAL. A FUMIGATION MANAGEMENT PLAN MUST BE WRITTEN FOR ALL FUMIGATOR'S PRIOR TO ACTUAL TREATMENT.

CONSULT WITH YOUR STATE LEAD PESTICIDE REGULATORY AGENCY TO DETERMINE REGULATORY STATUS, REQUIREMENTS, AND RESTRICTIONS FOR USE OF THIS FUMIGANT PRODUCT IN YOUR STATE. CALL UNITED PHOSPHORUS AT 1-800-438-6071 IF YOU HAVE ANY QUESTIONS OR DO NOT UNDERSTAND ANY PART OF THIS LABELING.

QuickPHlo - R™
GRANULES
Aluminum Phosphide Fumigant

FOR USE ONLY WITH UPI's QuickPHlo - R™ PHOSPHINE GENERATOR

FOR CONTROL OF PESTS OF STORED PRODUCTS

ACTIVE INGREDIENT - ALUMINUM PHOSPHIDE.....	77.5%
INERT INGREDIENTS.....	22.5%
	100.0%

THE USE OF THIS PRODUCT IS STRICTLY PROHIBITED ON SINGLE AND MULTI-FAMILY RESIDENTIAL PROPERTIES AND NURSING HOMES, SCHOOLS (EXCEPT ATHLETIC FIELDS) DAYCARE FACILITIES AND HOSPITALS.

PRECAUCION AL USUARIO: Si usted no lee ingles, no use este producto hasta que la etiqueta se le haya sido explicado ampliamente.

(TO THE USER: If you cannot read English, do not use this product until the label has been fully explained to you.)

KEEP OUT OF REACH OF CHILDREN
DANGER/PELIGRO - POISON



[IN RED]

ACCEPTED
With COMMENTS
In EPA Letter Dated:
SEP - 7 2010

Under the Federal Insecticide, Fungicide and Rodenticide Act, As amended, for the pesticide Registered under EPA Reg. No:

70506-69

FIRST AID	
Symptoms of exposure to this product are headaches, dizziness, nausea, difficult breathing, vomiting, and diarrhea. In all cases of overexposure get medical attention immediately. TRANSPORT victim to a doctor or emergency treatment facility.	
IF INHALED	<ul style="list-style-type: none"> • Move person to fresh air. • If person is not breathing, call 911 or an ambulance, then give artificial respiration

	<p>immediately, preferably by mouth-to-mouth.</p> <ul style="list-style-type: none"> • Keep warm and make sure person can breathe freely. • Contact a poison control center or doctor for treatment advice.
IF SWALLOWED	<ul style="list-style-type: none"> • Call a Poison control center or doctor immediately for treatment advice. • DO NOT INDUCE VOMITING UNLESS TOLD TO DO SO BY A POISON CONTROL CENTER OR DOCTOR. VOMITING MAY OFF-GAS AND RELEASE PHOSPHINE, WHICH COULD POSE A RISK OF SECONDARY CONTAMINATION. • DO NOT GIVE WATER (POTENTIAL ADDITIONAL FORMATION OF PHOSPHINE) UNLESS AUTHORIZED BY A PHYSICIAN. • Do not give anything by mouth to an unconscious person.
IF ON SKIN OR CLOTHING	<ul style="list-style-type: none"> • Brush or shake material off clothes and shoes in a well-ventilated area. • Allow clothes to aerate in a ventilated area prior to laundering. • Do not leave contaminated clothing in occupied and/or confined areas such as automobiles, vans, motel rooms, etc. • Wash contaminated skin thoroughly with soap and water.
IF IN EYES	<ul style="list-style-type: none"> • Hold eye open and rinse slowly and gently with water for 15 - 20 minutes. • Remove contact lenses, if present, after the first 5 minutes, then continue rinsing eye. • Call a poison control center or doctor for treatment advice.
<p>FOR CHEMICAL EMERGENCYS: SPILL, LEAK, FIRE EXPOSURE OR ACCIDENT CALL CHEMTREC 1-800-424-9300</p> <p>Have the product container or label with you when calling a poison control center or doctor, or going for treatment. Contact the Rocky Mountain Poison and Drug Center 866-673-6671 FOR ASSISTANCE WITH HUMAN OR ANIMAL MEDICAL EMERGENCIES.</p>	
<p>Note to Physician: QUICKPHLO-R® Granules reacts with moisture from the air, water, acids and many other liquids to release phosphine (hydrogen phosphide) gas. Mild exposure by inhalation causes malaise (indefinite feeling of sickness), ringing of ears, fatigue, nausea, and pressure in the chest, which is relieved by removal to fresh air. Moderate poisoning causes weakness, vomiting, pain just above the stomach, chest pain, diarrhea and dyspnea (difficulty in breathing). Symptoms of severe poisoning may occur within a few hours to several days, resulting in pulmonary edema (fluid in lungs) and may lead to dizziness, cyanosis (blue or purple skin color), unconsciousness, and death.</p> <p>In sufficient quantity, phosphine affects the liver, kidneys, lungs, nervous system and circulatory system. Inhalation can cause lung edema (fluid in lungs) and hyperemia (excess of blood in a body part), small perivascular brain hemorrhage and brain edema (fluid in brain). Ingestion can cause lung and brain symptoms but damage to the viscera (body cavity organs) is more common. Phosphine poisoning may result in (1) pulmonary edema, (2) liver elevated serum GOT, LDH and alkaline phosphatase, reduced prothrombin, hemorrhage and jaundice (yellow skin color) and (3) kidney hematuria (blood in urine) and anuria (abnormal lack of urination). Pathology is characterized by hypoxia (oxygen deficiency in blood tissue). Frequent exposure to subacute concentrations over a period of days or weeks may cause poisoning. Treatment is symptomatic.</p>	

See side panel for additional precautionary statements

Manufactured for:
United Phosphorus, Inc.
 630 Freedom Business Center
 King of Prussia, PA 19406
www.upi-usa.com • 1-800-438-6071

Net Contents: 80 x 0.125 kg, 40 x 0.550 kg, 4 x 2.2 kg and 4 x 4.4 kg pouches
 (80 x 0.275 lb, 40 x 1.21 lb, 4 x 4.85 lb and 4 x 9.69 lb)

EPA Reg. No. 70506-69
 EPA EST No. 41876-IND-1

[LEFT PANEL]

PRECAUTIONARY STATEMENTS

HAZARDS TO HUMANS AND DOMESTIC ANIMALS

DANGER. QUICKPHLO-R® Granules or dust can be fatal if swallowed. Do not get in eyes, on skin, or on clothing. Do not eat, drink or smoke while handling QuickPHlo R Granules. When a sealed container is opened, allowing material to come in contact with moisture, water or acids, toxic phosphine gas will be released. If a garlic odor is detected under certain conditions, refer to the section on Industrial Hygiene Monitoring in the Applicator's Manual. Pure phosphine gas is odorless; the garlic odor is due to a contaminant in the formulation. Since a garlic odor may not be detected under certain circumstances, the absence of an odor does not mean that phosphine gas is absent. Observe proper application, aeration, re-entry and disposal procedures specified elsewhere in the labeling to prevent overexposure.

ENVIRONMENTAL HAZARDS

This product is toxic to wildlife. Non-target organisms exposed to phosphine gas will be killed. Do not apply directly to water or wetlands (swamps, bogs, marshes, and potholes). Do not contaminate water by cleaning of equipment or disposal of wastes.

PHYSICAL AND CHEMICAL HAZARDS

QUICKPHLO-R® Granules and partially spent slurry will release phosphine gas if exposed to moisture from the air or if it comes into contact with water, acids and many other liquids. Since phosphine may ignite spontaneously at levels above its lower flammable limit of 1.8% v/v, it is important not to exceed this concentration. Ignition of high concentrations of phosphine can produce a very energetic reaction. Explosions can occur under these conditions and may cause severe personal injury. **Never allow the buildup of phosphine to exceed explosive concentrations.** Do not confine spent or partially spent granules, as the slow release of phosphine may result in formation of an explosive atmosphere. QUICKPHLO-R Granules outside its storage containers should not be stacked or piled up or contacted with liquid water. This may cause a temperature increase, increase the rate of gas production and confine the gas so that ignition could occur.

Under certain weather conditions, opening the pouches of QUICKPHLO-R® Granules in open air may produce a flash due to the phosphine build up. Containers may also be opened near a fan or other appropriate ventilation that will rapidly exhaust contaminated air. When opening, point the aluminum foil pouch away from the face and body and slowly cut open the pouch with a pair of scissors. Although the chances for a flash are very remote, never open these pouches in a flammable atmosphere. These precautions will also reduce the fumigator's exposure to phosphine gas.

Pure phosphine gas is practically insoluble in water, fats and oils, and is stable at normal fumigation temperatures. However, it may react with certain metals and cause corrosion, especially at higher temperatures and relative humidities. Do not handle the pouches with wet hands. Metals such as copper, brass and other copper alloys, and precious metals such as gold and silver are susceptible to corrosion by phosphine. Thus, small electric motors, smoke detectors, brass sprinkler heads, batteries and battery chargers, fork lifts, temperature monitoring systems, switching gears, communication devices, computers, calculators and other electrical equipment should be protected or removed before fumigation. Phosphine will also react with certain metallic salts and, therefore, sensitive items such as photographic film, some inorganic pigments, etc., should not be exposed. Immediately after addition of phosphine to the structure, turn off any lights and unessential electric equipment.

DIRECTIONS FOR USE

It is a violation of Federal Law to use this product in a manner inconsistent with its labeling. This product is for use against listed insects which infest stored commodities. Use the entire contents of a pouch. Do not leave any granules inside the pouch after opening.

QuickPHlo-R granules may only be used with the QuickPHlo-R Phosphine Generator to produce phosphine at the fumigation site. Refer to the Applicator's Manual for detailed lists of commodities, pests, application rates and sites

- 1. 2.
- 3.
- 4.

[RIGHT PANEL]

STORAGE AND DISPOSAL

Storage Instructions

1. Store QUICKPHLO-R® Granules in its original cardboard box. Store only in cool, dry, locked and ventilated room. Protect from moisture, open flames or heat. Post as a pesticide storage area. Do not contaminate water, food or feed by storing pesticides in the same areas used to store these commodities.
2. Do not store in buildings where humans or domestic animals reside. Keep out of reach of children.
3. QUICKPHLO-R® Granules are supplied in sealed aluminum foil pouches. After opening, do not expose the product to atmospheric moisture any longer than is necessary.
4. Unreacted and partially spent granules remaining in the generator, may be disposed of according to the instructions of the Manual (Disposal of Spent and Partially Reacted Granules, Section 22).
5. Do not leave individual pouches outside its original storage box for extended period of time.

Pesticide Disposal

Do not contaminate water, food or feed by storage or disposal. Do not remove pouches from the storage box until ready for fumigation. Unreacted or partially reacted QUICKPHLO-R® is acutely hazardous. Improper disposal of excess pesticide is a violation of Federal Law. If these wastes cannot be disposed of by use according to label instructions, contact your State Pesticide or Environmental Control Agency, or the Hazardous Waste representative at the nearest EPA Regional Office for guidance. For specific instructions, see the Disposal Instructions and Spill and Leak Procedures sections of the Applicator's Manual. Some local and state waste disposal regulations may vary therefore disposal procedures must be reviewed with appropriate authorities to ensure compliance with these regulations. Contact your state Pesticide or Environmental Control Agency or Hazardous Waste Specialist at the nearest EPA Regional Office for guidance.

Container and Spent Granules Disposal

Non-refillable container. Do not reuse this container. Offer for recycling. Dispose empty aluminum foil pouches in a sanitary landfill or by other procedures approved by state and local authorities. If properly exposed during the fumigation period, spent QUICKPHLO-R Granules will contain virtually no unreacted aluminum phosphide. This will be a non-hazardous waste. However, incompletely exposed Granules will require special care before disposal. For specific instructions, see the Disposal Instructions and Spill and Leak Procedures sections of the Applicator's Manual.

Spill and Leak Procedures

General Precautions and Directions

A spill may produce high levels of phosphine gas and, therefore, attending personnel must wear self contained breathing apparatus (SCBA) or its equivalent when the concentration of gas is unknown. Other NIOSH/MSHA approved respiratory protection may be worn if the concentration is known. Do **not** use water at any time to clean up a spill of QUICKPHLO-R® Granules. Water in contact with unreacted QUICKPHLO-R® Granules will greatly accelerate the production of phosphine gas which could result in a toxic and/or fire hazard. Wear dry gloves of cotton or other material when handling QuickPHLO-R Granules.

Return all intact aluminum foil pouches to the original cardboard box. Notify consignee and shipper of damaged cases.

If aluminum foil pouches have been punctured or damaged so as to leak, the container may be temporarily repaired with aluminum tape or the QUICKPHLO-R® Granules may be transferred from the damaged pouch to a sound metal container which should be sealed and properly labeled as QuickPHLO-R Granules. Transport the damaged containers to an open area suitable for pesticide inspection and storage. Caution: The punctured pouches may flash upon opening at some later time. Refer to the Applicator's Manual for more detailed Spill and Leak procedures.

**FOR CHEMICAL EMERGENCY: SPILL, LEAK, FIRE EXPOSURE, OR ACCIDENT,
CALL CHEMTREC 1-800-424-9300.**

**IMPORTANT INFORMATION
READ BEFORE USING PRODUCT**

CONDITIONS OF SALE AND LIMITATION OF WARRANTY AND LIABILITY

NOTICE: Read the entire Directions for Use and Conditions of Sale and Limitation of Warranty and Liability before buying or using this product. If the terms are not acceptable, return the product at once, unopened, and the purchase price will be refunded.

The Directions for Use of this product reflect the opinion of experts based on field use and tests, and must be followed carefully. It is impossible to eliminate all risks associated with the use of this product. Crop injury, ineffectiveness or other unintended consequences may result because of such factors as manner of use or application, weather or crop conditions, presence of other materials or other influencing factors in the use of the product, which are beyond the control of United Phosphorus, Inc. or Seller. Handling, storage, and use of the product by Buyer or User are beyond the control of United Phosphorus, Inc. and Seller. All such risks shall be assumed by Buyer and User, and Buyer and User agree to hold United Phosphorus, Inc. and Seller harmless for any claims relating to such factors.

TO THE EXTENT CONSISTENT WITH APPLICABLE LAW, UNITED PHOSPHORUS, INC. AND SELLER MAKE NO WARRANTIES OR MERCHANTABILITY OR OF FITNESS FOR A PARTICULAR PURPOSE NOR ANY OTHER EXPRESS OR IMPLIED WARRANTY EXCEPT AS STATED ON THIS LABEL.

To the extent consistent with applicable law, United Phosphorus, Inc. or Seller shall not be liable for any incidental, consequential or special damages resulting from the use or handling of this product and **THE EXCLUSIVE REMEDY OF THE USER OR BUYER, AND THE EXCLUSIVE LIABILITY OF UNITED PHOSPHORUS, INC. AND SELLER FOR ANY AND ALL CLAIMS, LOSSES, INJURIES OR DAMAGES (INCLUDING CLAIMS BASED ON BREACH OF WARRANTY, CONTRACT, NEGLIGENCE, TORT, STRICT LIABILITY OR OTHERWISE) RESULTING FROM THE USE OR HANDLING OF THIS PRODUCT, SHALL BE THE RETURN OF THE PURCHASE PRICE OF THE PRODUCT OR, AT THE ELECTION OF UNITED PHOSPHORUS, INC. OR SELLER, THE REPLACEMENT OF THE PRODUCT.**

United Phosphorus, Inc. and Seller offer this product, and Buyer and User accept it, subject to the foregoing conditions of sale and limitations of warranty and of liability, which may not be modified except by written agreement signed by the duly authorized representative of United Phosphorus, Inc.

7041

RESTRICTED USE PESTICIDE
DUE TO HIGH ACUTE INHALATION TOXICITY OF PHOSPHINE GAS
For retail sale to Dealers and Certified Applicators only. For use by Certified Applicators or persons under their direct supervision, and only for those uses covered by the Certified Applicator's certification. Refer to the directions in this Applicator's Manual for requirements of the physical presence of a Certified Applicator

THE COMPLETE LABEL FOR THIS PRODUCT CONSISTS OF THE CONTAINER LABEL AND APPLICATOR'S MANUAL. READ AND UNDERSTAND THE ENTIRE LABELING AND APPLICATOR'S MANUAL BEFORE USE. ALL PARTS OF THE LABELING AND APPLICATOR'S MANUAL ARE EQUALLY IMPORTANT FOR SAFE AND EFFECTIVE USE OF THE PRODUCT.

A FUMIGATION MANAGEMENT PLAN MUST BE WRITTEN FOR ALL FUMIGATIONS PRIOR TO ACTUAL TREATMENT.

CONSULT WITH YOUR STATE LEAD PESTICIDE REGULATORY AGENCY TO DETERMINE REGULATORY STATUS, REQUIREMENTS, AND RESTRICTIONS FOR FUMIGATION USE IN THAT STATE. CALL UNITED PHOSPHORUS, INC. AT 1-800-438-6071 IF YOU HAVE ANY QUESTIONS OR DO NOT UNDERSTAND ANY PART OF THIS LABELING.

APPLICATOR'S MANUAL FOR

**QuickPHlo - R™
Granules**

FOR USE ONLY WITH UPI'S QuickPHlo - R™ PHOSPHINE GENERATOR

Aluminum Phosphide Fumigant
FOR CONTROL OF PESTS OF STORED PRODUCTS

Active Ingredient: Aluminum Phosphide.....	77.5%
Inert Ingredients.....	22.5%
Total.....	100.0%

KEEP OUT OF REACH OF CHILDREN
DANGER/PELIGRO - POISON [in red]



[in red]

ACCEPTED
With COMMENTS
In EPA Letter Dated:
SEP - 7 2010

Under the Federal Insecticide, Fungicide and Rodenticide Act, As amended, for the pesticide Registered under EPA Reg. No:

70506-69

THE USE OF THIS PRODUCT IS STRICTLY PROHIBITED ON SINGLE AND MULTI-FAMILY RESIDENTIAL PROPERTIES AND NURSING HOMES, SCHOOLS (EXCEPT ATHLETIC FIELDS), DAYCARE FACILITIES AND HOSPITALS.

PRECAUCION AL USUARIO: Si usted no lee ingles, no use este producto hasta que la etiqueta se le haya sido explicado ampliamente. (TO THE USER: If you cannot read English, do not use this product until the label has been fully explained to you.)

FOR CHEMICAL EMERGENCY, SPILL, LEAK, FIRE, EXPOSURE OR ACCIDENT
CALL CHEMTREC 1-800-424-9300

80 of 41

Manufactured for:
United Phosphorus, Inc.
630 Freedom Business Center
King of Prussia, PA 19406
www.upi-usa.com • 1-800-438-6071

Net Contents: 80 x 0.125 kg, 40 x 0.550 kg, 4 x 2.2 kg and 4 x 4.4 kg
(80 x 0.275 lb, 40 x 1.21 lb, 4 x 4.85 lb and 4 x 9.69 lb)

EPA Reg. No. 70506-69
EPA EST No. 41876-IND-1

TABLE OF CONTENTS

	PAGE
1. FIRST AID	5
2. NOTE TO PHYSICIAN	5
3. INTRODUCTION	6 - 10
4. PRECAUTIONARY STATEMENTS	10
4.1 Hazards to Humans and Domestic Animals	
4.2 Environmental Hazards	
4.3 Physical and Chemical Hazards	
5. DIRECTIONS FOR USE	11
6. PESTS CONTROLLED	12
7. COMMODITIES WHICH MAY BE FUMIGATED WITH QUICKPHLO R GRANULES	12
7.1 Raw Agricultural Commodities, Animal Feed and Feed Ingredients	
7.2 Processed Foods	
7.3 Nonfood Commodities Including Tobacco	
8. EXPOSURE CONDITIONS	14
9. DOSAGE RATES	14
9.1 Maximum Allowable Dosage Range for Fumigation with QuickPHlo-R Granules	
9.2 Dosage Rates for Various Sites and Commodities	
10. PROTECTIVE CLOTHING	17
10.1 Gloves	
11. RESPIRATORY PROTECTION	17
11.1 When Respiratory Protection Must Be Worn	
11.2 Permissible Gas Concentration Ranges for Respiratory Protection Devices	
11.3 Requirements for Availability of Respiratory Protection	
12. REQUIREMENTS FOR CERTIFIED APPLICATOR'S PRESENCE AND TRAINING DURING FUMIGATION	17
12.1 Requirements for the Presence of a Certified Applicator	
12.2 Requirements for Authorized Training of Workers in Transit Vehicles	
13. GAS DETECTION EQUIPMENT	18
14. NOTIFICATION REQUIREMENTS	18
14.1 Authorities and On-Site Workers	
14.2 Incidents Involving These Products	
14.3 Theft of Products	
15. APPLICATOR AND WORKER EXPOSURE	19
15.1 Exposure Limits	
15.2 Generation of Phosphine Using the QuickPHlo-R Generator	

15.3 Leakage from Fumigated Sites
15.4 Aeration and Reentry
15.5 Handling Unaerated Commodities
15.6 Industrial Hygiene Monitoring
15.7 Engineering Controls and Work Practices

16. PLACARDING OF FUMIGATED AREAS 20

17. SEALING OF STRUCTURES 21

18. AERATION OF FUMIGATED COMMODITIES 21
18.1 Foods and Feeds
18.2 Non-Food Commodities
18.3 Tobacco

19. STORAGE INSTRUCTIONS 22
19.1 Labeling of Storage

20. TRANSPORT INSTRUCTIONS 23
20.1 Transportation Designations
20.2 Transportation Special Permit

21. REQUIRED WRITTEN FUMIGATION MANAGEMENT PLAN 24
21.1 Purpose
21.2 A Checklist Guide for a Fumigation Management Plan
A. Preliminary Planning and Preparation
B. Personnel
C. Monitoring
D. Notification
E. Sealing Procedures
F. Application Procedures and Fumigation Period
G. Post-Application Operations

22. APPLICATION PROCEDURES 27
22.1 Fumigation of Flat Storages, Bunkers and Other Tarpred Structures
22.2 Fumigation of Vertical Storages
22.3 Fumigation of Mills, Food Processing Plants and Warehouses
22.4 Fumigation of Railcars, Containers, Trucks, Vans, Other Transport Vehicles,
and Small Storages
22.5 Fumigation of Storage to Control Rodents and Other Non-Insect Pests
22.6 Fumigation of Shipholds
22.7 Barges

23. DISPOSAL OF SPENT OR PARTIALLY REACTED GRANULES 31
23.1 General
23.2 Disposal of Aluminum Pouches
23.3 Directions for Disposal of Unreacted or Partially Reacted QuickPHlo-R
Granules in the Generator
23.4 Deactivation of QuickPHlo-R Granules

24. SPILL AND LEAK PROCEDURES 32
24.1 General Precautions and Directions
24.2 Leaking Product Container Procedures
24.3 Spill Procedures
24.4 Direction for Deactivation of Granules by the Wet Method

SECTION 1

FIRST AID

Symptoms of exposure to this product are headaches, dizziness, nausea, difficult breathing, vomiting, and diarrhea. In all cases of overexposure get medical attention immediately. Transport victim to a doctor or emergency treatment facility.	
IF INHALED	<ul style="list-style-type: none"> • Move person to fresh air. • If person is not breathing, call 911 or an ambulance, then give artificial respiration immediately, preferably by mouth-to-mouth if possible. • Keep warm and make sure person can breathe freely. • Call a poison control center or doctor for further treatment advice.
IF SWALLOWED	<ul style="list-style-type: none"> • Call a poison control center or doctor immediately for treatment advice. • Do not induce vomiting unless told to do so by a poison control center or physician. • Vomiting may off-gas and release phosphine, which could pose a risk of secondary contamination. • Do not give water (potential additional formation of phosphine) unless authorized by a physician. • Do not give anything by mouth to an unconscious person.
IF ON SKIN OR CLOTHING	<ul style="list-style-type: none"> • Brush or shake material off clothes and shoes in a well-ventilated area. Allow clothes to aerate in a ventilated area prior to laundering. • Do not leave contaminated clothing in occupied and/or confined areas such as automobiles, vans, motel rooms, etc. • Wash contaminated skin thoroughly with soap and water.
IF IN EYES	<ul style="list-style-type: none"> • Hold eye open and rinse slowly and gently with water for 15 - 20 minutes. • Remove contact lenses, if present, after the first 5 minutes, then continue rinsing eye. • Call a poison control center or doctor for further treatment advice.
<p align="center">EMERGENCY CONTACT NUMBER CALL CHEMTREC 1-800-424-9300</p> <p>Have the product container label or Applicator's Manual with you when calling a poison control center or doctor or going for treatment.</p> <p>Contact the Rocky Mountain Poison Center 866-673-6671 for 24 hour emergency treatment, for assistance with human or animal medical emergencies.</p>	

SECTION 2

NOTE TO PHYSICIAN

QuickPHlo-R® Granules reacts with moisture from the air, water, acids and many other liquids to release phosphine gas. Mild inhalation exposure causes malaise (indefinite feeling of sickness), ringing of ears, fatigue, nausea, and pressure in the chest, which is relieved by removal to fresh air. Moderate poisoning causes weakness, vomiting, and pain just above the stomach, chest pain, diarrhea and dyspnea (difficulty in breathing). Symptoms of severe poisoning may occur within a few hours to several days, resulting in pulmonary edema (fluid in lungs) and may lead to dizziness, cyanosis (blue or purple skin color), unconsciousness, and death.

In sufficient quantity, phosphine affects the liver, kidneys, lungs, nervous system, and circulatory system. Inhalation can cause lung edema (fluid in lungs) and hyperemia (fluid in brain). Ingestion can cause lung and brain symptoms but damage to the viscera (body cavity organs) is more common. Phosphine

poisoning may result in (1) pulmonary edema, (2) liver elevated serum GOT, LDH and alkaline phosphatase, reduced prothrombin, hemorrhage and jaundice (yellow skin color) and (3) kidney hematuria (blood in urine) and anuria (abnormal lack of urination). Pathology is characterized by hypoxia (oxygen deficiency in body tissue). Frequent exposure to subacute concentrations over a period of days or weeks may cause poisoning. Treatment is symptomatic.

SECTION 3

INTRODUCTION

3.1 QUICKPHLO-R GRANULES

QuickPHlo – R Granules must only be used with the QuickPHlo – R Phosphine Generator and **not** for use in the manner conventionally employed by aluminum and magnesium phosphide tablets, pellets and rope fumigants. The Granules must **not** be added directly to raw or any other type of agricultural commodity. QuickPHlo – R Granules are for the exclusive use in a QuickPHlo – R Phosphine Generator for generating phosphine gas for fumigation of stored products to control insect and vertebrate pests.

QuickPHlo – R Granules in combination with **QuickPHlo – R Phosphine Generator**, are used to protect stored commodities from damage by insects and for control of rodents and other vertebrate pests. Fumigation of stored products with QuickPHlo – R Granules in the manner prescribed in the labeling does not contaminate the stored commodity because the granules do not come in direct contact with the stored commodity.

QuickPHlo – R Granules are acted upon by liquid water to produce phosphine (PH₃) gas.

QuickPHlo – R Granules contain aluminum phosphide as the active ingredient and will liberate phosphine via the following chemical reaction:

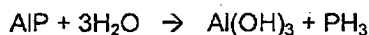

Phosphine gas is highly toxic to insects, vertebrate pests, humans, and other forms of animal life. The phosphine gas will corrode certain metals and may ignite spontaneously in air at concentrations above its lower flammable limit of 1.8% (v/v). These hazards are described in greater detail in the Precautionary Statements section of this Manual.

QuickPHlo – R Granules are greenish yellow in color and are up to 1.4 mm. in size. The QuickPHlo – R Granules are packed in sealed aluminum foil pouches containing 0.125 kg (0.275 lb.), 0.550 kg (1.21 lb.), 2.200 kg (4.85 lb.) or 4.400 kg (9.69 lb.) of product. Each aluminum foil pouch will generate upon contact with water 56 gm, 250 gm, 1,000 gm or 2,000 gm of phosphine, respectively, which equates to almost 1 gram of phosphine for each 2.2 gm of QuickPHlo – R Granules. The aluminum foil pouches are packed in card board, corrugated boxes and shipped in 3/5 ply corrugated fiberboard cartons. The chart below shows the recommended number of pouches to generate the desired amount of phosphine:

Grams Phosphine to be generated	Number of Pouches to Use				Total Number of Pouches
	125 g	550 g	2.2 kg	4.4 kg	
56 g	1				1
500 g		2			2
1 kg			1		1
1.25 kg		1	1		2
1.5 kg		2	1		3
2 kg			2		2
2.5 kg		2	2		4
3 kg			3		3
3 kg			1	1	2
3.5 kg		2	1	1	4
4.0 kg				2	2
5.0 kg			1	2	3
6.0 kg				3	3
7.0 kg			1	3	4
8.0 kg				4	4
9.0 kg			1	4	5
10.0 kg				5	5
Example: For 5.62 kg phosphine	2	2	1	2	7

Note:

Package size of Granules and amount of phosphine gas generated:

- 125 g Granules generates 56 g of phosphine
- 550 g Granules generates 250 g of phosphine
- 2.2 kg Granules generates 1 kg of Phosphine
- 4.4 kg Granules generates 2 kg of phosphine
- or
- 1.0 g of granule generates 0.45 g of phosphine equivalent to 11.3 ppm of phosphine/1000 cu.ft.

QuickPHlo – R Granules are packed in sealed aluminum foil pouches and their shelf life is unlimited as long as the packaging remains intact. The aluminum pouches containing QuickPHlo – R Granules cannot be resealed for future use. Storage and Handling instructions are given in detail in the Storage Instructions and Disposal Instructions sections of the Applicator's Manual. Precautions for and instructions for use of the generator equipment with **QuickPHlo – R Granules** are explained in the User's Operating Instruction Manual supplied with the generator equipment.

3.2. QUICKPHLO – R PHOSPHINE GENERATOR

QuickPHlo - R Phosphine Generator is an automatic equipment assembly for generation of phosphine gas from QuickPHlo - R granules. The equipment is portable and it can be used in any location. The Generator is placed outside the structure to be fumigated. United Phosphorus, Inc. will provide detailed training of all operators of the QuickPHlo – R Phosphine Generator including detailed written instructions in a User's Operating Instructions Manual.

QuickPHlo-R generator can use only the QuickPHlo-R granules to produce phosphine at the fumigation site.

A diagram of the Generator is shown in Figure 1, below.

FIGURE 1. GENERAL BLOCK DIAGRAM FOR QuickPHlo - R GENERATOR

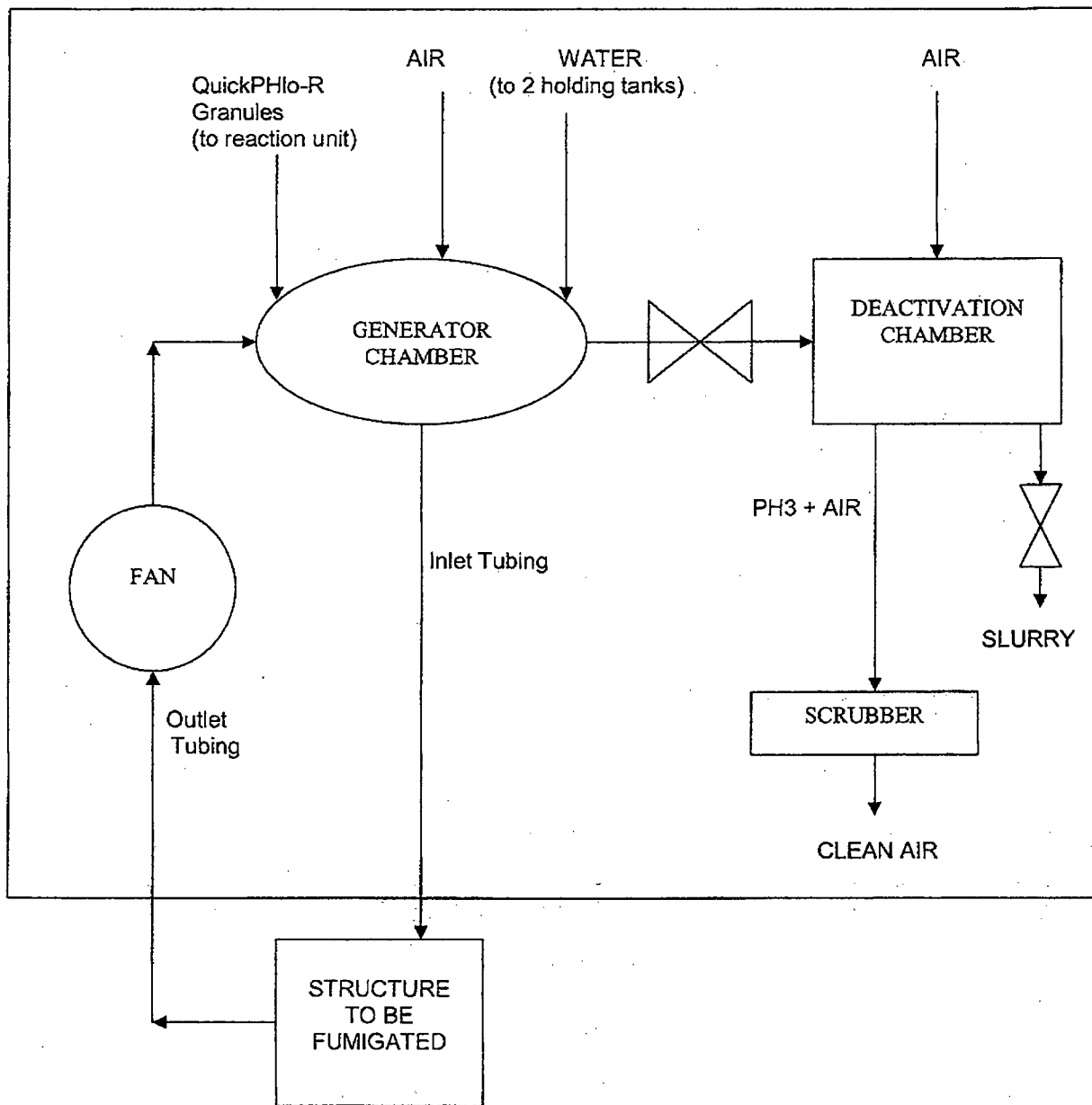

After the structure is prepared and secured for fumigation, the generator is connected to the structure to be fumigated with inlet and outlet tubings. The generator has a fan. The phosphine gas produced by the generator is delivered to the structure being fumigated and the gas is circulated by the fan back into the generator for recirculation. Most of the required phosphine gas is generated in approximately 90 to 120 minutes, depending on the size of the generator. The generation of gas does not depend on outside temperature or relative humidity. Never place the Generator inside the structure to be fumigated.

Doing these prechecks will ensure that there is no accumulation of gas in the generator.

Ensure that the **QuickPHlo – R Phosphine Generator** reaction unit is dry before addition of the **QuickPHlo – R Granules**. QuickPHlo – R Granules must not be exposed to outside sources of water during addition to the QuickPHlo – R generator reaction unit. Do not operate the generator if it is likely to get wet in the rain. Do not apply granules to the generator reaction unit in situations where rain condensate or outside sources of water can come in contact with the granules.

Depending upon the volume of structure to be fumigated, the required quantity of granular formulation (full packets only) is added to the reaction unit of the generator. After the generator is sealed, the operator adds a predetermined quantity of water to the reaction unit from a water tank mounted on the generator.

The operator must check the flow rates of phosphine gas to ensure that the desired system pressure is maintained as recommended in the **QuickPHlo – R Phosphine Generator User's Operating Instructions Manual**. The generator is designed to ensure that the phosphine generated is dispensed into the structure without any accumulation of gas in the reaction chamber.

The residue left behind in the reaction unit consists of a slurry of aluminum hydroxide, water and any remaining aluminum phosphide. That residue is flushed with water into a deactivation unit which is a part of the generator and is automatically sealed off from the rest of the generator to prevent phosphine exposure to the operator. Phosphine gas generated during this deactivation process is passed through a scrubber containing a special grade activated carbon. No phosphine is released from the deactivation unit or scrubber; only clean air is let off into atmosphere from the scrubber. All these operations are controlled automatically by a control panel. The phosphine in the slurry after deactivation drops to less than 0.1 %. After deactivation, the spent material is disposed of as described in Disposal Instructions section of this Manual.

As soon as the residue is flushed with water into the deactivation unit, it is safe to open the generator chamber. Ensure that the reaction chamber is dry before starting another fumigation with additional QuickPHlo R Granules.

1100-41

SECTION 4

PRECAUTIONARY STATEMENTS

4.1 HAZARDS TO HUMANS AND DOMESTIC ANIMALS

DANGER. QUICKPHLO-R® Granules or dust may be fatal if swallowed. Do not get in eyes, on skin, or on clothing. Do not eat, drink or smoke while handling QuickPHLO R Granules. When a sealed container is opened, allowing material to come in contact with moisture, water or acids, toxic phosphine gas will be released. If a garlic odor is detected under certain conditions, refer to the section on Industrial Hygiene Monitoring in Section 13.6 for appropriate monitoring and safety procedures. Pure phosphine gas is odorless; the garlic odor is due to a contaminant in the formulation. Since the odor of phosphine may not be detected under some circumstances, the absence of a garlic odor does not mean that dangerous levels of phosphine gas are absent. Observe proper application, aeration, re-entry procedures specified in Section 15.4 to prevent overexposure.

4.2 ENVIRONMENTAL HAZARDS

This product is highly toxic to wildlife. Non-target organisms exposed to phosphine gas will be killed. Do not apply directly to water or wetlands (swamps, bogs, marshes, and potholes). Do not contaminate water by cleaning of equipment or disposal of wastes.

4.3 PHYSICAL AND CHEMICAL HAZARDS

QUICKPHLO-R® Granules and partially spent slurry will release phosphine gas if exposed to moisture from the air or if it comes into contact with water, acids and many other liquids. Since phosphine may ignite spontaneously at levels above its lower flammable limit of 1.8% v/v (18,000 ppm), it is important not to exceed this concentration. Ignition of high concentrations of phosphine can produce a very energetic reaction. Explosions can occur under these conditions and may cause severe personal injury. **Never allow the buildup of phosphine to exceed explosive concentrations.** Do not confine spent or partially spent granules, as the slow release of phosphine may result in formation of an explosive atmosphere. QUICKPHLO-R Granules outside its containers should not be stacked or piled up or contacted with liquid water. This may cause a temperature increase, increase the rate of gas production and confine the gas so that ignition could occur.

Under certain weather conditions, opening the pouches of QUICKPHLO-R® Granules in open air, may produce a flash due to the phosphine build up. Containers may be opened near a fan or other appropriate ventilation that will rapidly exhaust contaminated air. When opening, point the aluminum foil pouch away from the face and body and slowly cut open the pouch with a pair of scissors. Although the chances for a flash are very remote, never open these pouches in a flammable atmosphere. These precautions will also reduce the fumigator's exposure to phosphine gas.

Pure phosphine gas is practically insoluble in water, fats and oils, and is stable at normal fumigation temperatures. However, it may react with certain metals and cause corrosion, especially at higher temperatures and relative humidities. Metals such as copper, brass and other copper alloys, and precious metals such as gold and silver are susceptible to corrosion by phosphine. Thus, small electric motors, smoke detectors, brass sprinkler heads, batteries and battery chargers, fork lifts, temperature monitoring systems, switching gears, communication devices, computers, calculators and other electrical equipment should be protected or removed before fumigation. Phosphine gas will also react with certain metallic salts and, therefore, sensitive items such as photographic film, some inorganic pigments, etc., should not be exposed. Immediately after addition of phosphine to the structure, turn off any lights and nonessential electric equipment.

QUICK-PHLO R GRANULES are Restricted Use Pesticides due to the acute inhalation toxicity of phosphine gas. Read and follow the entire label, which consist of the container label and Manual, which contains instructions for the authorized use(s) of the pesticide.

Additional copies of this Manual are available from:

United Phosphorus, Inc. (UPI)
630 Freedom Business Center
King of Prussia, PA 19406
Telephone: 1-610-491-2800/ 1-800-438-6071
FAX: 1-610-491-2810
Web site: www.upi-usa.com

SECTION 5

DIRECTIONS FOR USE

It is a violation of federal law to use this product in a manner inconsistent with its labeling.

QuickPHlo-R granules may only be used with the QuickPHlo-R Phosphine Generator to produce phosphine at the fumigation site.

QuickPHlo-R® Granules are Restricted Use Pesticides due to the acute inhalation toxicity of phosphine gas. Read and follow the entire label, which consist of the container label and manual for complete instructions for the safe use of this pesticide.

A fumigation management plan (FMP) must be developed by the certified applicator who is responsible for the entire fumigation process.

SECTION 6

PESTS CONTROLLED

QuickPHlo - R Granules can be used to control the following insects and their pre-adult stages; that is, eggs, larvae and pupae:

almond moth	European grain moth	Mediterranean flour moth
Angoumois grain moth	flat grain beetle	pink bollworm
bean weevil	fruit flies	raisin moth
Bees	granary weevil	red flour beetle
Cadelle	greater wax moth	rice weevil
cereal leaf beetle	hairy fungus beetle	rusty grain beetle
cigarette beetle	Hessian fly	saw-toothed grain beetle
confused flour beetle	Indian meal moth	spider beetle
dermestid beetles	Khapra beetle	tobacco moth
dried fruit beetle	lesser grain borer	yellow meal worm
dried fruit moth	maize weevil	pea weevil

Although it is possible to achieve total control of the listed insect pests, this is frequently not realized in actual practice. Factors contributing to less than 100% control include leaks, poor gas distribution, unfavorable exposure conditions, etc. In addition, some insects and/or their life stages are less susceptible to phosphine than others. If maximum control of the pests is to be attained, temperature and humidity conditions must be favorable, extreme care must be taken in sealing the structure, higher dosages must be used, exposure periods lengthened and proper application procedures must be followed.

SECTION 7

COMMODITIES WHICH MAY BE FUMIGATED WITH QuickPHlo-R® Granules

7.1 RAW AGRICULTURAL COMMODITIES, ANIMAL FEED AND FEED INGREDIENTS

QuickPHlo - R Granules may be used for the fumigation of listed raw agricultural commodities, animal feed and feed ingredients, processed foods, tobacco and certain other nonfood items.

**Raw Agricultural Commodities and Animal Feed and Feed Ingredients
Which May Be Fumigated with QuickPHlo-R® Granules**

almonds	filberts	rye
animal feed & feed ingredients	flower seed	safflower seed
barley	grass seed	sesame seed
brazil nuts	millet	seed & pod vegetables
cashews	oats	sorghum
cocoa beans	peanuts	soybeans
coffee beans	pecans	sunflower seeds
corn	pistachio nuts	triticale
cottonseed	popcorn	vegetable seeds
dates	rice	walnuts
		wheat

7.2 PROCESSED FOODS

Processed Foods Which May Be Fumigated With QuickPHlo-R® Granules

- Processed candy and sugar
- Cereal flours and bakery mixes
- Cereal foods (including cookies, crackers, macaroni, noodles, pasta, pretzels, snack foods and spaghetti)
- Processed cereals (including milled fractions and packaged cereals)
- Cheese and cheese byproducts
- Chocolate and chocolate products (such as assorted chocolate, chocolate liquor, cocoa, cocoa powder, dark chocolate coating and milk chocolate products)
- Processed coffee
- Corn grits
- Cured, dried and processed meat products
- Dates and figs
- Dried eggs and egg yolk solids
- Dried fish
- Dried milk, dried powdered milk, nondairy creamers, and nonfat dried milk
- Dried or dehydrated fruits (such as apples, dates, figs, peaches, pears, prunes, raisins, citrus and sultanas)
- Processed herbs, spices, seasonings and condiments
- Malt
- Processed nuts (such as almonds, apricot kernels, brazil nuts, cashews, filberts, macadamia nuts, peanuts, pecans, pistachio nuts, walnuts and other processed nuts)
- Processed oats (including oatmeal)
- Rice (brewer's rice grits, enriched and polished)
- Soybean flour and milled fractions
- Processed tea
- Dried and dehydrated vegetables (such as beans, carrots, lentils, peas, potato flour, potato products and spinach)
- Yeast (including primary yeast)
- Wild rice
- Other processed foods

7.3 NONFOOD COMMODITIES, INCLUDING TOBACCO

The listed nonfood items may be fumigated with QuickPHlo-R Granules. Granules should not come into direct contact with tobacco and other nonfood commodities.

Nonfood Commodities Which May Be Fumigated With QuickPHlo-R® Granules

- Processed or unprocessed cotton, wool and other natural fibers or cloth, clothing
- Straw and hay
- Feathers
- Human hair, rubberized hair, vulcanized hair, mohair
- Leather products, animal hides and furs
- Tires (for mosquito control)
- Tobacco
- Wood, cut trees, wood chips, wood and bamboo products
- Paper and paper products
- Dried plants and flowers
- Seeds (such as grass seed, ornamental herbaceous plant seed and vegetable seed)
- Other nonfood commodities

The use of this product is strictly prohibited on single and multi-family residential properties and nursing homes, schools (except athletic fields), daycare facilities and hospitals. For a list of approved sites see Section 22.

SECTION 8

EXPOSURE CONDITIONS

The QuickPHlo – R Phosphine generator produces phosphine gas very rapidly from the QuickPHlo – R Granules. Unlike metallic phosphides, it is not dependent upon external conditions like the temperature and humidity to generate phosphine. Therefore, QuickPHlo – R Phosphine Generator can be used under low humidity and/or low temperature. The minimum exposure periods for phosphine gas is 2 to 5 days under favorable weather and other fumigation conditions. Exposure periods may be lengthened to obtain better control of infestation even under conditions of poor sealing and penetration of gas throughout the commodity and lower temperatures. The following table may be used as a guide in determining the minimum length of the exposure period at the indicated temperatures:

<u>Temperature</u>	<u>Exposure Periods for Phosphine generated from QuickPHlo Generator</u>
Below 40°F (5°C)	6 to 15 days
40°-53°F (5-12°C)	4 to 10 days
54°-59°F (12-15°C)	3 to 5 days
60°-68°F (16-20°C)	2 to 4 days
above 68°F (20°C)	2 days

The fumigation must be long enough so as to provide for adequate control of the pests that infest the commodity being treated. The proper length of the fumigation period will vary with exposure conditions since, in general, insects are more difficult to control at lower temperatures. However, with the rapid production of phosphine by the QuickPHlo – R granules, regardless of ambient temperature and the quick distribution of gas in the fumigation structure/commodity it is possible to achieve satisfactory control even at relatively cooler conditions. To achieve a faster turn around during fumigation under tight sealing conditions, higher concentration of phosphine may be used but not exceeding the maximum application rate. It should be noted that there is little to be gained by extending the exposure period if the structure to be fumigated has not been carefully sealed, thereby insects are not subjected to lethal concentrations of phosphine. Careful sealing is required to maintain adequate gas levels and proper application procedures must be followed to provide satisfactory distribution of phosphine gas. Some structures can only be treated when completely tarped while others cannot be properly sealed by any means and should not be fumigated.

SECTION 9

DOSAGE RATES

Phosphine is a mobile gas and will penetrate to all parts of the storage structure if given enough time, even if the area is filled with commodity. Therefore, dosage must be based upon the total volume of the space being treated and not on the amount of commodity it contains. The same amount of QuickPHlo - R Granules is required to treat a 30,000-bushel silo whether it is empty or full of grain unless, of course, a tarpaulin seals off the surface of the commodity. Higher dosages are recommended for structures that are of loose construction and for the fumigation of bulk stored commodities in which diffusion of the gas is slow resulting in poor distribution of phosphine gas.

The quantity of phosphine produced by each of the package sizes of QuickPHlo – R Granules are as follows:

QuickPHlo – R Granules	Phosphine generated	Phosphine, equivalent per 1000 cu.ft. *
125 g pouch	56 g	1,400 ppm
550 g pouch	250 g	6,250 ppm
2.2 kg pouch	1000 g	25,000 ppm
4.4 kg pouch	2000 gr	50,000 ppm

* = 1 g of phosphine is equivalent to 25 ppm /1000 cu.ft. area

9.1 MAXIMUM ALLOWABLE DOSAGE RANGE FOR FUMIGATION WITH QUICKPHLO-R® GRANULES

After determining the quantity of stored commodity or area to be treated, calculate the quantity of QuickPHlo-R Granules required using the application rate table under Section 9.2. Use an adequate number of pouches (use an entire pouch) as required for the fumigation. The amount of phosphine to be used and generated is predetermined based on area to be fumigated, type of storage and other variables.

After calculating the amount in grams of granules needed for the size of the structure to be fumigated, determine the package size best suitable for use in the Generator. If multiple packages are used, and the phosphine concentration level in the structure has reached adequate levels for control of insect pests, then any excess phosphine or unused granules in the generator can be deactivated inside the Generator. Any excess phosphine gas which is generated during this deactivation step is passed through a scrubber containing a special grade activated carbon. No phosphine is released from the unit; only clean air is let off into atmosphere. It is important to be aware that a shortened exposure period cannot be fully compensated for with an increased dosage of phosphine.

Somewhat higher dosages, but not exceeding the maximum dosage, are usually recommended under cooler, or where exposure periods are relatively short. However, the major factor in selection of dosage is the ability of the structure to hold phosphine gas during the fumigation. A good illustration of this point is comparison of the low dosages required to treat modern, well-sealed warehouses with the higher doses used for structures that cannot be sealed adequately.

In certain fumigations, proper distribution of lethal concentrations of gas to reach all parts of the structure becomes a very important factor in dosage selection. Use of QuickPHlo-R- Granules can eliminate the problem of non-uniform gas concentrations. Another advantage for using the Granules is the ease of use and not having to reenter the treated structure by applicators to apply additional fumigant, as is the case with the metallic phosphides.

9.2 DOSAGE RATES FOR VARIOUS SITES AND COMMODITIES

When a dosage range is recommended, use the higher rate under conditions of severe infestation, lower temperature and other applicable variables. The following dosage ranges are based on bulk storage (per 1,000 bushels) or space fumigations (per 1,000 cu. ft.):

<u>Type of Fumigation</u>	<u>Dosage Range/1000 cu.ft.** QuickPHlo-R Granules (g)</u>
<u>Site Fumigation</u>	
1. Vertical Storages (such as silos, concrete bins, steel bins, tanks, etc.)	66-132
2. Farm Bins (Butler Type)	154-319
3. Railcars, containers, trucks, vans and other transport vehicles	66-143
4. Space fumigation (cereal mills, feed mills, food processing plants & warehouses)	44-132
5. Barges	66-176
6. Shipholds	66-143
<u>Commodity Fumigation</u>	
a. Bulk stored commodities in bunkers and commodities stored on ground loosely piled under gas-tight covering	66-176
b. Bulk stored commodities in flat storage and commodities stored on ground loosely piled under gas-tight covering	110-319
c. Packaged commodities (bagged grain, process foods, etc.) in sealable enclosures	66-132
d. Nuts, dates or dried fruit in storage boxes	44-88
e. All other commodities	44-319
f. Stored Tobacco	44-88
** Do not apply more than the recommended maximum rate depending upon the commodity or site being fumigated.	

SECTION 10

PROTECTIVE CLOTHING

10.1 GLOVES

Wear dry gloves of cotton or other material if contact with Granules is likely. Gloves should remain dry during use. Wash hands thoroughly after handling QuickPHlo R Granules. Prior to laundering, aerate used gloves and other clothing that may be contaminated in a well-ventilated area.

SECTION 11

RESPIRATORY PROTECTION

11.1 WHEN RESPIRATORY PROTECTION MUST BE WORN

Respiratory protection is required when concentration levels of phosphine are unknown.

11.2 PERMISSIBLE GAS CONCENTRATION RANGES FOR RESPIRATORY PROTECTION DEVICES

A NIOSH/MSHA approved full-face gas mask - phosphine canister combination may be used at levels up to 15 ppm or following manufacturer's use conditions instructions for escape. Above 15 ppm or in situations where the phosphine concentration is unknown, a NIOSH/MSHA approved, self-contained breathing apparatus (SCBA) must be worn. The NIOSH/OSHA Pocket Guide DHHS (NIOSH) 97-140 or the NIOSH ALERT – Preventing Phosphine Poisoning and Explosions During Fumigation lists these and other types of approved respirators and the concentration limits at which they may be used.

11.3 REQUIREMENTS FOR AVAILABILITY OF RESPIRATORY PROTECTION

If QuickPHlo R Granules is to be applied from within the structure to be fumigated, an approved full-face gas mask – phosphine canister combination or SCBA or its equivalent must be available at the site of application in case it is needed. Respiratory protection must be available for applications from outside the area to be fumigated such as addition of Granules to the Generator in outdoor situations, etc. The Generator may never be placed inside the structure to be fumigated.

SECTION 12

REQUIREMENTS FOR CERTIFIED APPLICATOR'S PRESENCE AND TRAINING DURING FUMIGATION

12.1 THE REQUIREMENTS FOR THE PRESENCE OF A CERTIFIED APPLICATOR AND THEIR RESPONSIBILITY FOR ALL WORKERS ARE AS FOLLOWS:

1. A Certified Applicator must be physically present, responsible for, and maintain visual and/or voice contact with all fumigation workers during the application of the fumigant. Once the application is complete and the structure has been made secure the certified applicator does not need to be physically present at the site.
2. A Certified Applicator must be physically present, responsible for and maintain visual and/or voice contact with all fumigation workers during the initial opening of the fumigation structure for aeration. Once the aeration process is secured and monitoring has established that aeration can be completed safely, the certified applicator does not need to be physically present and trained person(s) can complete the process and remove the placards.
3. Persons with documented training in the handling of phosphine fumigated products must be responsible for receiving, aerating and removal of placards from vehicles, which have been fumigated

in transit. Refer to the Requirements for Certified Applicator's Presence and Training for Receipt of In-Transit Vehicles Under Fumigation section of this manual for training requirements.

- 4. A Certified Applicator must be present on site with at least one trained worker when entering a area under fumigation for initiating aeration, gas level measurements, repairing leaks or other trouble shooting.
- 5. A Certified Applicator must be present on site when a trained worker is operating the generator. It is the responsibility of the certified applicator that at the end of fumigation, the generator is disconnected from the fumigation chamber and the spent granules and waste slurry is processed and disposed of safely and properly.

12.2 THE REQUIREMENTS FOR AUTHORIZED TRAINING OF WORKERS IN TRANSIT VEHICLES

The trained person(s) must be trained by a Certified Applicator following the EPA-accepted product applicator's manual that must precede or be attached to the outside of a transport vehicle; or by other training which is accepted by local and or state authorities. When training has been completed and the employee demonstrates safety knowledge proficiency, the training date must be logged and maintained in the employee's safety training record for a minimum of three years. Refresher training must be done on an annual basis.

This training must cover the following items, each of which may be found in this manual:

- a. How to aerate the vehicle and verify that it contains no more than 0.3 ppm phosphine.
- OR**
- b. How to transfer the commodity to another storage area without prior aeration and ensure that worker safety limits are not being exceeded during the transfer.
- c. How to determine when respiratory protection must be worn.
- d. How to protect workers and nearby persons from exposure to levels above the 8-hour time weighted average (TWA) of 0.3 ppm or the 15 minute TWA short-term exposure limit (STEL) of 1.0 ppm phosphine.
- e. Proper removal of placards and release of the fumigated commodity.
- f. How to follow proper residual disposal instructions.

SECTION 13

GAS DETECTION EQUIPMENT

There are a number of devices on the market for the measurement of phosphine gas at both industrial hygiene and fumigation levels. Glass detection tubes used in conjunction with the appropriate hand-operated air sampling pumps are widely used. These devices are portable, simple to use, do not require extensive training and are relatively rapid, inexpensive and accurate. Electronic devices are also available for both low level and high phosphine gas readings. Such devices should be used in full compliance with manufacturers' recommendations.

SECTION 14

NOTIFICATION REQUIREMENTS

14.1 AUTHORITIES AND ON-SITE WORKERS

As required by local regulations, notify the appropriate local officials (fire department, police department, etc.) of the impending fumigation. Provide to the officials an Material Safety Data Sheet (MSDS) and an Applicator's Manual for the product and any other technical information deemed useful. Offer to review this information with the local official(s).

14.2 INCIDENTS INVOLVING THESE PRODUCTS

Registrants must be informed of any incident involving the use of this product. Please call 1-800-438-6072 so United Phosphorus Inc. can report the incident to Federal and State Authorities.

14.3 THEFT OF PRODUCTS

Immediately report to the local police department about theft of QuickPHlo R Granules.

SECTION 15

APPLICATOR AND WORKER EXPOSURE

Approved respiratory protection must be worn if concentrations exceed the allowable limits, or when concentrations are unknown.

15.1 EXPOSURE LIMITS

Exposure to phosphine must not exceed the 8-hour Time Weighted Average (TWA) of 0.3 ppm or the 15 minute TWA short-term exposure limit (STEL) of 1.0 ppm phosphine. All persons are covered by these exposure standards.

15.2 GENERATION OF PHOSPHINE USING THE QUICKPHLO-R GENERATOR

Since no entry into the fumigated structure is required to apply the fumigant, only a certified applicator or trained person under the direct supervision of the certified applicator may operate the QuickPHlo – R – Generator. The certified applicator is also responsible for disconnecting the generator at the end of generation and disposing of the spent granules safely and properly.

The QuickPHlo – R Phosphine Generator greatly reduces exposures of phosphine to the applicator since the gas is generated internally in the equipment assembly and pumped into the structure through pipes. Sealed aluminum foil pouches containing QuickPHlo – R Granules are opened, one at a time, to add the granules to the QuickPHlo – R Phosphine Generator. The QuickPHlo – R Phosphine Generator is always positioned outside the storage structure to be treated.

Ensure that the QuickPHlo – R Phosphine Generator reaction unit is dry before addition of the QuickPHlo – R Granules. QuickPHlo – R Granules must not be exposed to outside sources of water during addition to the QuickPHlo – R generator reaction unit. Do not operate if the generator is likely to get wet in the rain and do not apply granules to the generator reaction unit in situations where rain condensate or outside sources of water can come in contact with the granules.

The residue left behind in the reaction unit consists of a slurry of aluminum hydroxide, water and any remaining aluminum phosphide. That residue is flushed with water into a deactivation unit which is a part of the generator and is automatically sealed off from the rest of the generator to prevent phosphine exposure to the operator. Phosphine gas which is being generated during this deactivation process is passed through a scrubber containing a special grade activated carbon. No phosphine is released from the deactivation unit or scrubber; only clean air is let off into atmosphere from the scrubber. All these operations take place automatically through a control panel. The phosphine in the slurry after deactivation drops to less than 0.1 %. After deactivation, the spent material is disposed of as described in Disposal Instructions section of the Applicator's Manual.

As soon as the residue is flushed with water into the deactivation unit, it is safe to open the generator chamber, dry it completely and then start another fumigation with additional QuickPHlo R Granules, if needed.

The required amount of water is placed into the holding tank unit of the generator only after the predetermined quantity of granules is placed in a separate section of the reaction unit. The system is sealed and phosphine generation starts instantly after the operator initiates the controls of the Generator.

15.3 LEAKAGE FROM FUMIGATED SITES

Phosphine is highly mobile and given enough time may penetrate seemingly gas-tight materials such as concrete and cinder block. Therefore, adjacent, enclosed areas likely to be occupied should be examined to ensure that significant leakage has not occurred. Sealing of the fumigated site and/or airflow in the occupied areas must be sufficient to bring down the phosphine concentration to a safe level of 0.3 ppm or below.

15.4 AERATION AND REENTRY

The areas neighboring the fumigation site must be monitored to ensure that escape of gas from the treated commodity does not result in the development of unacceptable levels i.e., over industrial hygiene levels of phosphine. Do not allow reentry into treated structures by any person before the level of phosphine reaches 0.3 ppm or below unless protected by an approved respirator. For reentry into an area under fumigation, a certified applicator plus a minimum of one trained worker must be present.

If the structure is to be entered after fumigation, a NIOSH/MSHA approved full-face gas mask - phosphine canister combination may be used at levels up to 15 ppm or following manufacturer's use conditions instructions for escape. Above 15 ppm or in situations where the phosphine concentration is unknown, a NIOSH/MSHA approved, self-contained breathing apparatus (SCBA) must be worn. The NIOSH/OSHA Pocket Guide DHHS (NIOSH) 97-140 or the NIOSH ALERT - Preventing Phosphine Poisoning and Explosions During Fumigation lists these and other types of approved respirators and the concentration limits at which they may be used.

15.5 HANDLING UNAERATED COMMODITIES

Transfer of incompletely aerated commodity via bulk handling equipment such as augers, drag conveyors and conveyor belts to a nearby storage structure is permissible. A Certified Applicator is responsible for training workers who handle the transfer of incompletely aerated listed commodities, and appropriate measures must be taken (i.e., ventilation or respiratory protection) to prevent exposures from exceeding the exposure limits for phosphine. The new storage structure must be placarded if it contains more than 0.3 ppm phosphine. If the fumigation structure must be entered to complete the transfer, at least two trained persons, wearing proper respiratory protection may enter the structure. A certified applicator must be physically present during the entry into the structure.

REMEMBER transporting containers or vehicles under fumigation over public roads is prohibited.

15.6 INDUSTRIAL HYGIENE MONITORING

Phosphine exposures must be documented in an operations log or manual at each fumigation site and operation where exposures may occur. Monitor airborne phosphine concentrations in all indoor areas to which fumigators and other workers have had access during fumigation and aeration. Perform such monitoring in workers' breathing zones. This monitoring is mandatory and is performed to determine when and where respiratory protection is required. Once exposures have been adequately characterized, spot checks must be made, especially if conditions change significantly or if an unexpected garlic odor is detected or a change in phosphine level is suspected.

15.7 ENGINEERING CONTROLS AND WORK PRACTICES

If monitoring shows that workers may be exposed to concentrations in excess of the permitted limits, then engineering controls (such as forced air ventilation) and/or appropriate work practices must be used to reduce exposure to within permitted limits. In any case, appropriate respiratory protection must be worn if phosphine exposure limits are exceeded.

SECTION 16

PLACARDING OF FUMIGATED AREAS

All entrances to the fumigated structure must be placarded. Placards must be made of substantial

27041

material that can be expected to withstand adverse weather conditions and must bear the wording as follows:

1. The signal word DANGER/PELIGRO and the SKULL AND CROSSBONES symbol in red.
2. The statement "Area/Structure and/or commodity under fumigation, DO NOT ENTER/NO ENTRE".
3. The Statement, "This sign may only be removed by a certified applicator or a person with documented training after the commodity is completely aerated and checked to contain 0.3 ppm or less of phosphine gas. If incompletely aerated commodity is transferred to a new structure, the new structure must also be placarded if it contains more than 0.3 ppm phosphine. Worker exposure during this transfer must not exceed allowable limits."
4. The date the fumigation begins.
5. Trade name of the fumigant used and EPA Registration Number.
6. Name, address and telephone number of the fumigation company and/or applicator.
7. A 24-hour emergency response telephone number.

All entrances to a fumigated structure must be placarded. Where possible, placards should be placed in advance of the fumigation to keep unauthorized persons away. For in-transit fumigated railroad hopper cars and trucks, placards must be placed on both sides of the car near the ladders and next to the top hatches into which the fumigant is introduced.

Do not remove placards until the treated commodity is aerated down to 0.3 ppm phosphine or less. To determine whether aeration is complete, each fumigated structure or vehicle must be monitored and shown to contain 0.3 ppm or less phosphine gas in the air space around and, if feasible, in the mass of the commodity.

SECTION 17

SEALING OF STRUCTURES

The structure to be fumigated must first be inspected to determine if it can be made sufficiently gas tight. Careful sealing is required so that adequate gas levels are retained. Turn off all ventilation, supply air, air conditioning, and any other air moving systems which could negatively affect the fumigation. Thoroughly inspect the structure to be fumigated and seal cracks, holes and openings. These areas could include, but are not limited to: windows, doors, vents, chimneys, open pipes and structural flaws. Sealing techniques can vary, but most often include polyethylene sheeting, adhesive tapes and adhesive sprays. Expandable foam or caulking material can work well on structural flaws. Proper sealing will insure sufficient gas levels within the fumigated structure and will decrease the chance of unwanted exposures outside of the fumigated area.

As with all fumigations, it is required that sealing be inspected for leaks. If phosphine above 0.3 ppm is found in an area where exposure to workers or bystanders may occur, the applicator, using proper respiratory protection equipment must attempt to seal the leak from the exterior of the structure. Failing this, the applicator, following proper procedures to prevent accidental poisoning, may enter the structure and seal the leaks from the inside. For entering a structure under fumigation, at least two trained persons, wearing proper respiratory protection may enter the structure. A certified applicator must be physically present during the entry into the structure. If the concentration inside the structure has decreased below the target level as a result of the leakage, additional fumigant may be added following the sealing repairs.

DO NOT FUMIGATE A STRUCTURE THAT CANNOT BE SEALED SUFFICIENTLY GAS-TIGHT.

SECTION 18

AERATION OF FUMIGATED COMMODITIES

As an alternative to the minimum aeration time of 48 hours listed below, each treated commodity may be analyzed for residues of phosphine using accepted analytical methods.

18.1 FOODS AND FEEDS

Tolerances for phosphine residues have been established at 0.1 ppm for raw agricultural commodities and animal feeds and 0.01 ppm for processed foods, fresh fruits and vegetables. To guarantee compliance with these tolerances, it is necessary to aerate these commodities for a minimum of 48 hours prior to offering them to the end consumer.

18.2 NON-FOOD COMMODITIES

Aerate all non-food commodities to 0.3 ppm or less of phosphine. Monitor densely packed commodities to ensure that aeration is complete.

18.3 TOBACCO

Tobacco must be aerated for at least three days (72 hours) when fumigated in hogsheads and for at least two days (48 hours) when fumigated in other containers or until the concentration is below 0.3 ppm. When plastic liners are used, longer aeration periods will probably be required to aerate the commodity down to 0.3 ppm.

SECTION 19

STORAGE INSTRUCTIONS

1. Store QUICKPHLO-R® Granules in its original cardboard box. Store only in cool, dry, locked and ventilated room. Protect from moisture, open flames or heat. Post as a pesticide storage area. Do not contaminate water, food or feed by storing pesticides in the same areas used to store these commodities.
2. Do not store in buildings where humans or domestic animals reside. Keep out of reach of children.
3. QUICKPHLO-R® Granules are supplied in sealed aluminum foil pouches. After opening, do not expose the product to atmospheric moisture any longer than necessary.
4. Unreacted and partially spent granules remaining in the generator, may be disposed of according to the instructions of the Manual (Disposal of Spent and Partially Reacted Granules, Section 22).
5. Do not leave individual pouches outside its original storage box for extended periods of time.

QuickPHlo - R Granules are supplied in aluminum foil pouches. Do not expose the granules to atmospheric moisture any longer than necessary. **QuickPHlo - R Granules** should not be stored at sub-zero temperatures because this will increase the possibility of an ignition (flash) when opened. The shelf life of **QuickPHlo - R Granules** is virtually unlimited as long as the aluminum foil pouches are sealed.

19.1 LABELING OF STORAGE

The labeling of the storage area should take into account the needs of a variety of regulatory organizations. These should include, but not be limited to: corporate policy, insurance carrier, Occupational Safety and Health Administration (OSHA), Emergency Planning and Community Right-To-Know ACT and local emergency response professionals. At a minimum, the storage must be marked with the following signs and should be locked:

1. Danger, Poison (with skull and cross bones)
2. Authorized Personnel Only
3. Pesticide Storage NFPA Hazard Identification Symbols

The National Fire Protection Association (NFPA) has developed Hazard Identification Symbols for hazardous chemicals. This standardized system is designed to provide, at a glance, the information regarding the health, fire and reactivity hazards associated with hazardous materials. The following are the hazard categories and degree of hazard for aluminum phosphide:

<u>Category</u>	<u>Degree of Hazard</u>
-----------------	-------------------------

29041

Health	4 (Severe Hazard)
Flammability	4 (Severe Hazard)
Reactivity	2 (Moderate)
Special Notice Key	W

NOTE: When using the NFPA Hazard Identification System, the characteristics of all hazardous materials stored in a particular area must be considered. The local fire protection district should be consulted for guidance on the selection and placement of such signs.

SECTION 20

TRANSPORTATION INSTRUCTIONS

The United States Department of Transportation (DOT) classifies aluminum phosphide as Dangerous When Wet material and it must be transported in accordance with DOT regulations.

20.1 TRANSPORT DESIGNATIONS

The following transport designations apply to aluminum phosphide

Proper Shipping Name: Aluminum phosphide
 Hazard Class: 4.3
 Identification No.: UN 1397
 Packing Group: PG I
 Shipping Label: Dangerous When Wet/Poison
 Shipping Placard: Dangerous When Wet

20.2 Transportation Special Permit

Special Permit ; DOT- SP 13307

Specific placarding requirements are excepted when shipped under the transportation mode, operational controls, and in packaging as authorized under this Special Permit.

Authorized transportation Mode : Motor vehicle only (private carrier)

Operational controls : Single motor vehicle may not contain more than 21 kilograms of aluminum phosphide pesticides and packages must be stowed within metal boxes or metal compartments within each motor vehicle.

Packaging: Combinatin package consisting of a UN4G fiberboard box with inner aluminum canisters containing not more than 1.5 kilograms of aluminum phosphide which is cushioned against movement within the outer UN4G box.

Special Provision: A copy of the Special Permit must be carried aboard each motor vehicle used to transport under the Special Permit.

Copies of the Special Permit can be obtained from UPI or via DOT website as follows:

UPI
 630 Freedom Business Center, Suite 402
 King of Prussia, PA 19406
 Tele 1-800-438-6071

DOT website : http://hazmat.dot.gov/sp_app/special_permits/spec_perm_index.htm

SECTION 21

REQUIRED WRITTEN FUMIGATION MANAGEMENT PLAN

The certified applicator is responsible for working with the owners and/or responsible employees of the structure and/or area to be fumigated to develop and follow a Fumigation Management Plan (FMP). State, County, and local authorities may also have specific requirements. The FMP must be written PRIOR TO EVERY treatment. The FMP must address characterization of the site, and include appropriate monitoring and notification requirements, consistent with, but not limited to, the following:

1. The use of this product is strictly prohibited on single and multi-family residential properties and nursing homes, schools (except athletic fields), daycare facilities and hospitals. For a list of approved sites see Section 22.
2. Inspect the site to determine its suitability for fumigation.
3. When sealing is required, consult previous records for any changes to the structure, seal leaks, and monitor any occupied adjacent buildings to ensure safety.
4. Prior to each fumigation, review any existing FMP, MSDS, Applicator's Manual and other relevant safety procedures with company officials and appropriate employees.
5. Consult company officials in the development of procedures and appropriate safety measures for nearby workers that will be in and around the area during application and aeration.
6. Consult with company officials to develop an appropriate monitoring plan that will confirm that nearby workers and bystanders are not exposed to levels above the allowed limits during application, fumigation and aeration. This plan must also demonstrate that nearby residents will not be exposed to concentrations above the allowable limits.
7. Consult with company officials to develop procedures for local authorities to notify nearby residents in the event of an emergency.
8. Confirm the placement of placards to secure entrance into any structure under fumigation.
9. Confirm the required safety equipment is in place and the necessary manpower is available to complete a safe effective fumigation.
10. Written notification must be provided to the receiver of a vehicle that is fumigated in transit.

These factors **must** be considered in putting together an FMP. It is important to note that some plans will be more comprehensive than others. All plans should reflect the experience and expertise of the applicator and circumstances at and around the site.

In addition to the plan, the applicator must read the entire label, which includes container label and manual, and must follow its directions carefully. If the applicator has any questions about the development of a FMP, contact United Phosphorus, Inc. for further assistance.

The FMP and related documentation, including monitoring records, must be maintained for a minimum of 2 years.

STEPS FOR PREPARATION OF THE REQUIRED WRITTEN FUMIGATION MANAGEMENT PLAN

21.1 PURPOSE

A Fumigation Management Plan (FMP) is an organized, written description of the required steps involved to help ensure a safe, legal, and effective fumigation. It will also assist you and others in complying with pesticide product label requirements. The guidance that follows is designed to help assist you in addressing all the necessary factors involved in preparing for and fumigating a site.

This guidance is intended to help you organize any fumigation that you might perform PRIOR TO ACTUAL TREATMENT. It is meant to be somewhat prescriptive, yet flexible enough to allow the experience and expertise of the fumigator to make changes based on circumstances which may exist in the field. By following a step-by-step procedure, yet allowing for flexibility, safe and effective fumigation

can be performed.

Before any fumigation begins, carefully read and review the label and the Applicator's Manual. This information must also be given to the appropriate company officials (supervisors, foreman, safety officer, etc.) in charge of the site. Preparation is the key to any successful fumigation. If you do not find specific instructions for the type of fumigation that you are to perform listed in this Guidance Document, you will want to construct a similar set of procedures using this document as your guide or contact United Phosphorus for assistance. Finally, before any fumigation begins, you must be familiar with and comply with all applicable federal, state and local laws. The success and future of fumigation are not only dependent on your ability to do your job but also by carefully following all rules, regulations, and procedures required by governmental agencies.

21.2 A CHECKLIST GUIDE FOR A FUMIGATION MANAGEMENT PLAN

This checklist is provided to help you take into account factors that must be addressed prior to performing all fumigations. It emphasizes safety steps to protect people and property. The checklist is general in nature and cannot be expected to apply to all types of fumigation situations. It is to be used as a guide to prepare the required plan. Each item must be considered. However, it is understood that each fumigation is different and not all items will be necessary for each fumigation site.

A. PRELIMINARY PLANNING AND PREPARATION

1. Determine the purpose of the fumigation.
 - a. Elimination of insect infestation
 - b. Elimination of vertebrate pest infestation
 - c. Plant pest quarantine.
2. Determine the type of fumigation, for example
 - a. Space: tarp, mill, warehouse, food plant
 - b. Vehicle: railcar, truck, van, container
 - c. Commodity: raw agricultural or processed foods
 - d. Type of Storage: vertical silo, farm storage, flat storage
 - e. Vessels: ship or barge. In addition to the Applicator's Manual, read the US Coast Guard Regulations 46 CFR 147A.
3. Fully acquaint yourself with the site and commodity to be fumigated, including.
 - a. The general structure layout, construction (materials, design, age, maintenance) of the structure, fire or combustibility hazards, connecting structures and escape routes, above and below ground, and other unique hazards or structure characteristics. Prepare, with the owner/operator/person in charge. Draw or have a drawing or sketch of structure to be fumigated, delineating features, hazards, and other structural issues.
 - b. The number and identification of persons who routinely enter the area to be fumigated (i.e., employees, visitors, customers, etc.)
 - c. The specific commodity to be fumigated, its mode of storage, and its condition.
 - d. The previous treatment history of the commodity, if available.
 - e. Accessibility of utility service connections.
 - f. Nearest telephone or other means of communication, and mark the location of these items on the drawing/sketch.
 - g. Emergency shut-off stations for electricity water and gas. Mark the location of these items on the drawing/sketch.
 - h. Current emergency telephone numbers of local Health, Fire, Police, Hospital and Physician responders.
 - i. Name and phone number (both day and night) of appropriate company officials.
 - j. Check, mark and prepare the points of fumigation application locations if the job involves entry into the structure for fumigation.
 - k. Review the entire label which includes the container label and Manual. In addition, review the Operator's Manual for the QuickPHlo - R Phosphine Generator.
 - l. Exposure time considerations.
 1. Product (Granules) to be used.
 2. Minimum fumigation period, as defined and described in the use directions of the

Applicator's Manual.

- 3. Down time required to be available
- 4. Aeration requirements
- 5. Cleanup requirements, equipment, and personnel needs, if necessary.
- 6. Measured and recorded commodity temperature and moisture.
- m. Determination of dosage
 - 1. Cubic footage or other appropriate space/location calculations.
 - 2. Structure sealing capability and methods.
 - 3. Label recommendations
 - 4. Temperature, humidity, wind
 - 5. Commodity/space volume
 - 6. Past history of fumigation of structure
 - 7. Exposure time.

B. PERSONNEL

- 1. Confirm in writing that all personnel in and around the structure to be fumigated have been notified prior to application of the fumigant. Consider using a checklist that each employee initials indicating they have been notified.
- 2. Instruct all fumigation personnel to read the Applicator's Manual and about the hazards that may be encountered and about the selection of personal protection devices, including detection equipment.
- 3. Confirm that all personnel are aware of and know how to proceed in case of an emergency situation.
- 4. Instruct all personnel on how to report any accident and/or incidents related to fumigant exposure. Provide a telephone number for emergency response reporting.
- 5. Instruct all personnel to report to proper authorities any theft of fumigant and/or equipment related to fumigation.
- 6. Establish a meeting area for all personnel in case of emergency.

C. MONITORING

- 1. Safety
 - a. Monitoring of phosphine conditions must be conducted in areas to prevent excessive exposure and to determine where exposure may occur. Document where monitoring will occur.
 - b. Keep a log or manual of monitoring records for each fumigation site. This log must at a minimum contain the timing, number of readings taken and level of concentrations found in each location.
 - c. When monitoring, document even if there is no phosphine present. In such cases, subsequent monitoring is not routinely required. However spot checks must be made occasionally, especially if conditions significantly change.
 - d. Monitoring must be conducted during aeration and corrective action taken if gas levels exceed the allowed levels in an area where bystanders and/or nearby residents or domestic animals may be exposed.
- 2. Efficacy
 - a. Phosphine readings should be taken from within the fumigated structure to insure proper gas concentrations. If the phosphine levels have fallen below the targeted level, the fumigators may generate additional phosphine using QuickPHlo - R Granules in the QuickPHlo - R Phosphine Generator.
 - b. All phosphine readings should be documented.

D. NOTIFICATION

- 1. Confirm that the appropriate local authorities (fire departments, police departments, etc.) have been notified as per label instructions, local ordinances, or instructions of the client.
- 2. Prepare written procedure ("Emergency Response Plan") which contains explicit instructions, names, and telephone numbers so as to be able to notify local authorities if phosphine levels are exceeded in an area that could be dangerous to bystanders and or domestic animals.

3. Confirm that the receivers of in-transit vehicles under fumigation have been notified and are trained according to the Requirements for Certified Applicator's Presence and Training for Receipt of In-Transit Vehicles Under Fumigation section of this manual.

E. SEALING PROCEDURES

1. Sealing must be adequate to control the pests. Care should be taken to insure that sealing materials will remain intact until the fumigation is complete.
2. If the site has been fumigated before, review the previous FMP for previous sealing information.
3. Make sure that construction/remodeling has not changed the building in a manner that will affect the fumigation.
4. Warning placards must be placed on every possible entrance to the fumigation site.

F. APPLICATION PROCEDURES AND FUMIGATION PERIOD

1. Plan carefully and apply the product in accordance with the label requirements.
2. When entering into the area under fumigation always work with two or more people under the direct supervision of a certified applicator wearing appropriate respirators.
3. Apply fumigant from the outside where appropriate.
4. Provide watchmen when entry into the fumigation site by unauthorized persons cannot otherwise be assured.
5. When entering structures always follow OSHA rules for confined spaces.
6. Document that the receiver of in-transit vehicles/containers under fumigation has been notified.
7. Turn off any electric lights in the fumigated area of the structure as well as all nonessential electrical motors.

G. POST-APPLICATION OPERATIONS

1. Provide watchmen when you cannot secure the fumigation site from entry by unauthorized persons during the aeration process.
2. Ventilate and aerate in accordance with structural limitations.
3. Turn on ventilating or aerating fans where appropriate.
4. Use a suitable gas detector before reentry into a fumigated structure to determine fumigant concentration.
5. Keep written records of monitoring to document completion of aeration.
6. Consider temperature when aerating.
7. Ensure aeration is complete before moving a treated vehicle onto public roads.
8. Remove warning placards when aeration is complete.
9. Inform business/client that employees/other persons may return to work or otherwise be allowed to reenter the aerated structure.

SECTION 22

APPLICATION PROCEDURES

An FMP MUST BE WRITTEN PRIOR to all applications.

An FMP must be devised to cover application and exposure period, aeration and disposal of the fumigant so as to keep to a minimum any human exposures to phosphine and to help assure adequate control of the insect pests.

22.1 FUMIGATION OF FLAT STORAGE, BUNKERS AND OTHER TARPED STRUCTURES

1. Establish a plan for application of phosphine gas depending upon the characteristics of the structure to be treated. For example, it is difficult to treat a flat storage containing grain at depths

340941

greater than 20 feet and having no aeration ducts or distribution ducts unless the storage is sealed very carefully.

2. If the structure has no distribution ducts, the surface of the commodity must be carefully tarped and the remainder of the building sealed as tightly as possible.
3. Using the Applicator's Manual, determine the length of the fumigation and calculate the dosage of Granules to be used in the Generator based upon volume of the building, air and/or commodity temperature and the general tightness of the structure.
4. Warning placards must be placed on every possible entrance to the fumigation site.
5. Connect the distribution lines from the Generator to the structure to be fumigated. Inject and recirculate phosphine gas from QuickPHlo- R Phosphine Generator through the distribution ducts. Depending upon the size of the storage, it may be necessary to make injections of gas at several points if necessary to achieve more uniform distribution of the gas. Following the introduction of phosphine gas from QuickPHlo- R Phosphine Generator, the distribution lines should be capped or sealed.
6. Phosphine concentrations should be measured at several times throughout the term of the fumigation and at places within the treatment area to verify the lethal concentration throughout the commodity.
7. When the fumigation is complete, aerate as appropriate using precautions to prevent exposure to workers (see Section 13.4 on Aeration and Reentry). Adequate monitoring and aeration must be performed to reduce any residual phosphine levels to below 0.3 ppm.

22.2. FUMIGATION OF VERTICAL STORAGEES (concrete upright bins, farm bins, and other silos in which grain can be rapidly transferred)

1. Carefully seal and place fumigation warning placards on the storage.
2. Smaller bins and silos may be fumigated by circulation of phosphine gas produced by the Generator, in a manner similar to that employed for warehouses.
3. For fumigation of larger vertical storages, leave an opening of 2 sq. ft. or more at the top of the structure. This will prevent a build-up of pressure from gas pumped into the storage.
4. Consult previous records for any changes to the structure. Close openings and seal cracks to make the structure as airtight as possible. Prior to the fumigation, seal the vents near the bin top which connect to adjacent bins.
5. Using the Applicator's Manual, determine the length of the fumigation and calculate the dosage of Granules to be used in the Generator based upon volume of the building, air and/or commodity temperature and the general tightness of the structure.
6. Warning placards must be placed on every possible entrance to the fumigation site.
7. Connect the distribution lines from the Generator to the storage to be fumigated. Inject and recirculate phosphine from the QuickPHlo- R Phosphine Generator through the distribution ducts or at points below the surface of the commodity, if possible. Depending upon the size of the storage, it may be necessary to make injections of gas at several points if necessary to achieve more uniform distribution of the gas.
8. Phosphine concentrations should be measured at several times during the fumigation and at places within the treatment area to verify that lethal concentrations are attained throughout the commodity.
9. When the fumigation is complete, aerate as appropriate using precautions to prevent exposure to workers (see Section 13.4 on Aeration and Reentry). Adequate monitoring and aeration must be performed to reduce any residual phosphine levels to below 0.3 ppm.

22.3 FUMIGATION OF MILLS, FOOD PROCESSING PLANTS, AND WAREHOUSES

1. Using the Applicator's Manual, determine the length of the fumigation and calculate the dosage of Granules to be used in the Generator based upon volume of the building, air and/or commodity temperature and the general tightness of the structure.
2. Turn off all lights within the area to be treated and shut off all electrical motors not essential to operation of storage.
3. Carefully seal and place warning placards on the space to be fumigated. Doors leading to the fumigated space must be closed, sealed, and placarded with warning signs.
4. Attach the inlet and outlet tubing from the QuickPHlo- R Phosphine Generator fan to the

structure to be fumigated. Add the **QuickPHIo – R Granules** to the **QuickPHIo- R Phosphine Generator**. Ensure the generator reaction unit is dry. Inject and re-circulate phosphine gas through the aeration ducts or at points below the surface of the grain, if possible. Depending upon the size of the storage, it may be necessary to make injections of gas at several points if necessary to achieve more uniform distribution of the gas.

5. Upon completion of the exposure period, windows, doors, vents, etc., should be opened and the fumigated structure allowed to aerate. The structure should not be entered without proper Personal Protective Equipment (PPE) unless gas readings have been taken and the concentration is below the allowable limits. Gas concentration readings may be taken using low level detector tubes or similar devices to ensure safety of personnel who reenter the treated area.
6. Collect the spent QuickPHIo-R dust and dispose of it, with or without further deactivation. Refer to Disposal Instructions in the Disposal Instructions section of this Manual.

22.4 FUMIGATION OF RAILCARS, CONTAINERS, TRUCKS, VANS, OTHER TRANSPORT VEHICLES AND SMALL STORAGES

Develop an appropriate Fumigation Management Plan.

Transport vehicles, including railcars, containers, trucks, vans, and other small storages loaded with bulk commodities may be treated with phosphine gas generated using QUICK-PHIO R Granules and the QUICK-PHIO – R Generator.

1. Establish a plan for application of phosphine gas depending upon the characteristics of the vehicle or small storage to be treated.
2. Using the Applicator's Manual, determine the length of the fumigation and calculate the dosage of Granules to be used in the Generator based upon volume of the vehicle or trailer.
3. Inspect all sidewalls, roof, floor and doors for cracks, holes or defects. Seal all openings with tape or caulk. Particular attention should be paid to any drain holes in the floor.
4. Warning placards must be placed on every possible entrance to the fumigation site.
5. Connect the distribution lines from the Generator to the vehicle or structure to be fumigated. Inject and re-circulate phosphine gas from QuickPHIo- R Phosphine Generator through the distribution ducts. Following the introduction of phosphine gas from QuickPHIo- R Phosphine Generator, the distribution lines should be capped or sealed. Disconnect the QuickPHIo R Generator before the vehicles are transported.
6. Phosphine concentrations should be measured at places within the treatment area to verify the lethal concentration throughout the commodity.
7. Notify the consignee if the commodity is to be shipped under fumigation. If the consignee is unfamiliar with proper handling of fumigated rail cars and containers fumigated in-transit, it is recommended that they be provided with the necessary information. See Sections 10, 14, and 16 of this manual for recommendations on training of persons authorized to remove placarding and commodity aeration.
8. Aeration of railcars, railroad boxcars, containers and other vehicles is prohibited en-route.
9. Moving in-transit fumigated containers or vehicles over public roads is prohibited.

vertebrate

22.6 FUMIGATION OF SHIPHOLDS

22.6.1 General Information

Important – In-transit ship or shiphold fumigation is also governed by U.S. Coast Guard Regulation 46 CFR 147A, Interim Regulations for Shipboard Fumigation. Refer to this regulation prior to fumigation. For further information contact:

Commandant U.S. Coast Guard
Hazardous Materials Standards Division, GMSO-3
Washington, DC 20593-0001

3/00/41

22.6.2 Pre-Voyage Fumigation Procedures for In-Transit Fumigation- A FMP must be written for all fumigations PRIOR TO ACTUAL TREATMENT.

1. Prior to fumigating a vessel before the vessel leaves the port, the master of the vessel, or his representative, and the certified applicator must determine whether the vessel is suitably designed and configured so as to allow for safe occupancy by the ship's crew throughout the duration of the fumigation. If it is determined that the design and configuration of the vessel does not allow for safe occupancy by the ship's crew throughout the duration of the fumigation, then the vessel will not be fumigated unless all crew members are removed from the vessel. The crew members will not be allowed to reoccupy the vessel until the vessel has been properly aerated and the master of the vessel and the certified applicator has made a determination that the vessel is safe for occupancy.
2. The certified applicator must notify the master of the vessel, or his representative, of the requirements relating to personal protection equipment*, detection equipment, and that a person qualified in the use of this equipment must accompany the vessel with cargo under fumigation. Emergency procedures, cargo ventilation, periodic monitoring and inspections, and first aid measures must be discussed with and understood by the master of the vessel or his representative.
**Note: Personal protection equipment means a NIOSH/MSHA approved respirator or gas mask fitted with an approved canister for phosphine. The canister is approved for use up to 15 ppm. SCBA or its equivalent must be used above 15 ppm or at unknown concentrations.*
3. Seal all openings to the cargo hold or tank and lock or otherwise secure all openings, man ways, etc., which might be used to enter the hold. The over space pressure relief system of each tank aboard tankers must be sealed by closing the appropriate valves and sealing the openings into the over space with gas-tight materials.
4. Using the application manual, determine the length of the fumigation and calculate the dosage of Granules to be used based upon volume of the vessel, air and/or commodity temperature and the general tightness of the vessel.
5. Placard all entrances to the treated spaces with fumigation warning signs.
6. Connect the distribution lines from the Generator to the vessel. Inject and re-circulate phosphine gas from QuickPHlo- R Phosphine Generator through the distribution ducts. Following the introduction of phosphine gas from QuickPHlo- R Phosphine Generator, the distribution lines should be capped or sealed. Seal up all openings. The QuickPHlo -R Generator must be disconnected and removed from the vessel before it leaves port.
7. If the fumigation is not completed and the vessel aerated before the manned vessel leaves port, the person in charge of the vessel shall ensure that at least two units of personal protection equipment and one gas or vapor detection device and a person qualified in their operation be on board the vessel during the voyage.
8. During the fumigation, or until a manned vessel leaves port or the cargo is aerated, the certified applicator shall ensure that a qualified person using phosphine gas detection equipment tests spaces adjacent to areas containing fumigated cargo as well as all regularly occupied spaces for fumigant leakage. If leakage of the fumigant is detected, the person in charge of the fumigation shall take action to correct the leakage, or shall inform the master of the vessel, or his representative, of the leakage so that corrective action can be taken.
9. The person in charge of the fumigation shall review with the master, or his representative, the precautions and procedures to follow during the voyage of a shiphold in-transit fumigation.

22.6.3. Application Procedures for Bulk Dry Cargo Vessels and Tankers

1. Carefully seal and place fumigation warning placards on the vessel or tanker. Add Granules to the QuickPHlo - R Phosphine Generator. The generated phosphine is introduced into the vessel or tanker. After the fumigation is complete, the Generator is disconnected from the fumigated structure and removed from the vessel before it leaves port.
2. Immediately after application of the fumigant, close and secure all hatch covers, tank tops, Butterworth valves, man ways, etc. The gas can be continuously re-circulated within the vessel or tanker using the vessel's or tanker's circulation fan.

37041

3. If the fumigation is not completed and the vessel aerated before the manned vessel leaves port, the person in charge of the vessel shall ensure that at least two units of personal protection equipment and one gas or vapor detection device and a person qualified in their operation be on board the vessel during the voyage.
4. During the fumigation, or until a manned vessel leaves port or the cargo is aerated, the certified applicator shall ensure that a qualified person using phosphine gas detection equipment tests spaces adjacent to areas containing fumigated cargo as well as all regularly occupied spaces for fumigant leakage. If leakage of the fumigant is detected, the person in charge of the fumigation shall take action to correct the leakage, or shall inform the master of the vessel, or his representative, of the leakage so that corrective action can be taken.

22.6.4. Precautions and Procedures During Voyage

1. Using appropriate gas detection equipment, monitor spaces adjacent to areas containing fumigated cargo and all regularly occupied areas for fumigant leakage. If leakage is detected, the area should be evacuated of all personnel, ventilated, and action taken to correct the leakage before allowing the area to be occupied.
2. Do not enter areas fumigated with QuickPHlo – R Granules except under emergency conditions. If necessary to enter a fumigated area, appropriate personal protection equipment must be used (see Section 21.6.5 Precautions and Procedures During Discharge). Never enter fumigated areas alone. At least one other person, wearing personal protection equipment, should be available to assist in case of an emergency.

22.6.5. Precautions and Procedures During Discharge

If necessary to enter holds prior to aeration, test spaces directly above grain surface for phosphine concentrations using appropriate gas detection and personal safety equipment. Do not allow entry to fumigated areas without personal safety equipment, unless phosphine concentrations are at safe levels, as indicated by a suitable detector. Also see Section 13.5 for re-entry procedures.

22.7 Barges

Barge fumigation is also regulated by U. S. Coast Guard Regulation 46 CFR 147A as modified by U. S. Coast Guard Special Permit 2-75. This permit which must be obtained prior to the fumigation is available from:

Commandant U. S. Coast Guard
Hazardous Materials Standards Div. GMSO-3
Washington, DC 20593-0001

Leaks are a common cause of failures in the treatment of commodities aboard barges. Carefully inspect all hatch covers prior to application of QuickPHlo – R Granules and seal, if necessary. Placard the barge. The barges must not be fumigated in-transit.

SECTION 23

DISPOSAL OF SPENT OR PARTIALLY REACTED GRANULES

23.1 GENERAL

Do not contaminate water, food or feed by storage or disposal.

Unreacted or partially reacted QuickPHlo - R Granules is acutely hazardous. Improper disposal of excess pesticide is a violation of Federal Law. If these wastes cannot be disposed of by use according to the Applicator's Manual, contact your State Pesticide or Environmental Control Agency, or the Hazardous Waste representative at the nearest EPA Regional Office for guidance. For specific instructions, see the Spill and Leak Procedures in the Spill and Leak Procedures section of this Manual.

Some local and state waste disposal regulations may vary therefore disposal procedures must be

380941

reviewed with appropriate authorities to ensure compliance with local regulations. Contact your state Pesticide or Environmental Control Agency or Hazardous Waste Specialist at the nearest EPA Regional Office for guidance.

23.2 DISPOSAL OF ALUMINUM POUCHES

Non-refillable container. Do not reuse this container. Offer for recycling. Dispose empty aluminum foil pouches in a sanitary landfill or by other procedures approved by state and local authorities. If properly exposed during the fumigation period, spent QUICKPHLO-R Granules will contain virtually no unreacted aluminum phosphide. This will be a non-hazardous waste. However, incompletely exposed Granules will require special care before disposal. For specific instructions, see the Disposal Instructions and Spill and Leak Procedures sections of the Manual.

23.3 DIRECTIONS FOR DISPOSAL OF UNREACTED OR PARTIALLY REACTED QuickPHlo-R® - GRANULES IN THE GENERATOR

The residual slurry remaining in the reaction chamber of the Generator, after fumigation with QuickPHlo - R Granules is a grayish liquid. This will be a non-hazardous waste and contain only a small amount of unreacted aluminum phosphide. However, residual slurry from incompletely reacted QuickPHlo - R Granules must be further deactivated within the QuickPHlo - R Phosphine Generator (see below) before disposal at a landfill. Confinement of partially spent QuickPHlo-R Granules may result in a fire hazard. Small amounts of phosphine gas may be given off from unreacted Granules and confinement of the gas may result in a flash.

23.4 DEACTIVATION OF QUICKPHLO - R GRANULES

Any leftover (unreacted) granules remaining inside the reaction chamber of the generator are deactivated in a separate chamber situated within the generator assembly. The QuickPHlo - R Phosphine Generator is equipped with a deactivation chamber to deactivate the residue left after application of QuickPHlo - R Granules. The spent slurry left over from the application of QuickPHlo - R Granules is flushed with water in the deactivation chamber and the liberated phosphine is scrubbed in the scrubber. The spent slurry remaining after the deactivation process is a non-hazardous waste and may be disposed of at a sanitary landfill or other approved sites or other means without prior decanting. Where permissible, the slurry or the decanted water from the slurry may be disposed of by on-site burial.

SECTION 24

SPILL AND LEAK PROCEDURES

24.1 GENERAL PRECAUTIONS AND DIRECTIONS

A spill QuickPHlo - R Granules may produce high levels of gas and, therefore, attending personnel must wear SCBA or its equivalent when the concentration of phosphine gas is unknown. Other NIOSH/MSHA approved respiratory protection may be worn if the concentration is known. Do not use water at any time to clean up a spill of QuickPHlo-R. Water in contact with unreacted Granules or pellets will greatly accelerate the production of phosphine gas that could result in a toxic and/or fire hazard. Wear dry gloves of cotton or other material when handling QuickPHlo R Granules.

Check corrugated cartons and aluminum foil pouches. If they are damaged, handle as described below. Return the pouches in good condition to the cardboard cartons or other suitable packaging which complies with DOT regulations and storage and handling safety parameters.

24.2 LEAKING PRODUCT CONTAINER PROCEDURES

Transport the damaged QuickPHlo - R Granules aluminum foil pouches to an open area away from

humidity and moisture, suitable for pesticide inspection. If QuickPHlo – R Granules aluminum foil pouches have been punctured or damaged causing a leak,

- 1) the product in the pouches may be immediately used,
- 2) the pouches may be temporarily repaired and closed with aluminum tape, OR
- 3) the granules may be deactivated either in the QuickPHlo-R Generator or by the Wet Method described below and then dispose of the residue.

24.3 SPILL PROCEDURES

DO NOT flush spillage down drain with water. DO NOT use water at any time to clean up a spill. Water in contact with unreacted QuickPHlo – R Granules will rapidly accelerate the production of phosphine and could cause spontaneous ignition of the gas. If the spill is only a few minutes old and is not contaminated by other materials, collect the spillage and place it back into the original pouch and tightly seal with aluminum tape. If possible, use immediately. CAUTION: AN IGNITION MAY OCCUR WHEN THESE CONTAINERS ARE REOPENED.

Since the QuickPHlo – R Granules are placed in small aluminum foil pouches, a spill will be a small quantity of powder spilled from a punctured pouch. Consequently, spills are not likely to constitute a frequent problem but the material must not be collected and stored as this might result in a dangerous build-up of phosphine which is not only highly toxic but can also cause a fire and explosion. Collect the spillage properly and deactivate it in the QuickPHlo – R Phosphine Generator or by using the Wet Method for Deactivation. Remember to wear NIOSH/MSHA approved or other suitable respiratory protection when handling spills and during deactivation.

NOTE : Never place granules or the dust/water slurry in a confined container such as a closed drum or plastic bags. Any phosphine generated will be confined and may decompose explosively.

24.4 DIRECTIONS FOR DEACTIVATION OF GRANULES BY WET METHOD

Caution: - Wear a NIOSH/MSHA approved full-face gas mask – phosphine canister combination (if exposed to levels between 0.3 ppm and 15 ppm) or a Self Contained Breathing Apparatus (SCBA) (if exposure is unknown or above 15 ppm) during wet deactivation of partially spent material. Do not cover the container being used for wet deactivation. Do not dispose of QuickPHlo – R Granules dust in a toilet.

If the contaminated material is not to be held until completely reacted by exposure to atmospheric moisture, deactivate the Granules by the "Wet Method" as follows:

- 1. Deactivating solution is prepared by adding low sudsing detergent or surface-active agent to water in a drum or other suitable container. A 2% solution or 4 cups in 30 gallons is suggested. The container should be filled with deactivating solution to within a few inches of the top.
- 2. The Granules should be poured slowly into the deactivating solution and stirred so as to thoroughly wet all of the Granules. This should be done in the open air. Do not cover the container being used for wet deactivation. Granules may react very vigorously with water and only a small amount of unexposed or partially exposed Granules should be deactivated at one time. Fresh additions may be added as soon as the vigorous reaction of the Granules has subsided. QuickPHlo-R Granules should be mixed into no less than about 15 gallons of water-detergent solution for each case of material.
- 3. Allow the mixture to stand, with occasional stirring for about 6 hours to ensure total hydrolysis. Removal of the Granules from water before they are largely deactivated may result in a fire. The resultant slurry will then be safe for disposal. Dispose of the slurry of deactivated material at a sanitary landfill or other suitable site approved by local authorities. Where permissible, this slurry may be poured into a storm sewer or out onto the ground.

FOR CHEMICAL EMERGENCY, SPILL, LEAK, FIRE, EXPOSURE OR ACCIDENT

40041

CALL CHEMTREC 1-800-424-9300

**IMPORTANT INFORMATION
READ BEFORE USING PRODUCT**

CONDITIONS OF SALE AND LIMITATION OF WARRANTY AND LIABILITY

NOTICE: Read the entire Directions for Use and Conditions of Sale and Limitation of Warranty and Liability before buying or using this product. If the terms are not acceptable, return the product at once, unopened, and the purchase price will be refunded.

The Directions for Use of this product reflect the opinion of experts based on field use and tests, and must be followed carefully. It is impossible to eliminate all risks associated with the use of this product. Crop injury, ineffectiveness or other unintended consequences may result because of such factors as manner of use or application, weather or crop conditions, presence of other materials or other influencing factors in the use of the product, which are beyond the control of United Phosphorus, Inc. or Seller. Handling, storage, and use of the product by Buyer or User are beyond the control of United Phosphorus, Inc. and Seller. All such risks shall be assumed by Buyer and User, and Buyer and User agree to hold United Phosphorus, Inc. and Seller harmless for any claims relating to such factors.

TO THE EXTENT CONSISTENT WITH APPLICABLE LAW, UNITED PHOSPHORUS, INC. AND SELLER MAKE NO WARRANTIES OR MERCHANTABILITY OR OF FITNESS FOR A PARTICULAR PURPOSE NOR ANY OTHER EXPRESS OR IMPLIED WARRANTY EXCEPT AS STATED ON THIS LABEL.

To the extent consistent with applicable law, United Phosphorus, Inc. or Seller shall not be liable for any incidental, consequential or special damages resulting from the use or handling of this product and **THE EXCLUSIVE REMEDY OF THE USER OR BUYER, AND THE EXCLUSIVE LIABILITY OF UNITED PHOSPHORUS, INC. AND SELLER FOR ANY AND ALL CLAIMS, LOSSES, INJURIES OR DAMAGES (INCLUDING CLAIMS BASED ON BREACH OF WARRANTY, CONTRACT, NEGLIGENCE, TORT, STRICT LIABILITY OR OTHERWISE) RESULTING FROM THE USE OR HANDLING OF THIS PRODUCT, SHALL BE THE RETURN OF THE PURCHASE PRICE OF THE PRODUCT OR, AT THE ELECTION OF UNITED PHOSPHORUS, INC. OR SELLER, THE REPLACEMENT OF THE PRODUCT.**

United Phosphorus, Inc. and Seller offer this product, and Buyer and User accept it, subject to the foregoing conditions of sale and limitations of warranty and of liability, which may not be modified except by written agreement signed by the duly authorized representative of United Phosphorus, Inc.