

SEP 17 2008

Mr. Vincent Opaskar  
Quality Borate  
3690 Orange Place, Suite #495  
Cleveland, OH 44122

Subject: Label Amendment  
EPA Registration Number: 69529-3  
Application Dated: August 15, 2008  
Decision: 396900

Dear Mr. Opaskar:

The labeling referred to above, submitted in connection with registration under the Federal Insecticide, Fungicide, and Rodenticide Act, as amended, is acceptable subject to the comment listed below. Five copies of the finished labeling must be submitted prior to releasing the product for shipment.

On page number 5, under the subheading, "PREVENTATIVE TREATMENT", correct "t" to read "to".

If you have any questions, please contact Melody Banks on (703) 305-5413.

Sincerely,

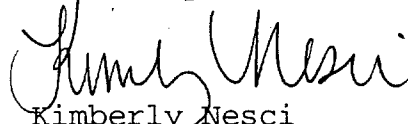

Kimberly Nesci  
Product Manager 11  
Insecticide Branch  
Registration Division (7505P)

Enclosure: Stamped Label "Accepted With" Comments"

2/07

# BoraSol Liquid

Manufactured by: Quality Borate Co., 3690 Orange Place, #495  
Cleveland, OH 44122

Phone: 1-866-BORATES (866-267-2837)

FOR PROTECTION AND PREVENTATIVE TREATMENT OF WOOD AGAINST TERMITES, REMEDIAL CONTROL OF SUCH PESTS IN INFESTED WOOD, PRESSURE TREATMENT AND DIP-DIFFUSION TREATMENT.

**ACTIVE INGREDIENT:**

Disodium Octaborate Tetrahydrate (Na<sub>2</sub>B<sub>8</sub>O<sub>13</sub> • 4H<sub>2</sub>O) ..50%

**INERT INGREDIENTS:**.....50%

EPA Reg. No. 69529-3 EPA Est. No. 01508-OH-001

(10.8 lbs/gallon)

**KEEP OUT OF REACH OF CHILDREN**

**Precautionary Statement:**

**Hazardous to humans and domestic animals**

ACCEPTED  
with COMMENTS  
in EPA Logo Brand

SEP 17 2008

Under the Federal Insecticide, Fungicide, and Rodenticide Act as amended, for the pesticide registered under EPA Reg. No. 69529-3

## C A U T I O N

Harmful if swallowed. Avoid contact with eyes. Wash thoroughly after handling. Avoid contamination of food and feed. Do not leave container where children or animals may gain access. Have the product or label with you when calling a Poison Control Center or Doctor or going for treatment. In case of emergency, for additional information call (866-267-2837).

	FIRST AID
If swallowed	-Call poison control center or doctor immediately for treatment advice. -Have person sip a glass of water if able to swallow. -Do not induce vomiting unless told to do so by the poison control center or doctor. -Do not give anything by mouth to an unconscious person.
If in eyes	-Hold eye open and rinse slowly and gently with water for 15-20 minutes. -Remove contact lenses, if present, after the first 5 minutes, then continue rinsing eye. -Call a poison control center or doctor for treatment advice.
If on skin or clothing	- Rinse skin with plenty of water for 15-20 minutes. -Take off contaminated clothing. -Call poison control center or doctor for additional treatment advice.
If Inhaled	-Move person to fresh air. -If person is not breathing, call 911 or an ambulance, then give artificial respiration, preferably by mouth-to-mouth, if possible -Call a poison control center or doctor for further advice.

### Personal Protection Equipment

Applicators and other handlers must wear a long-sleeved shirt and long pants which cover the entire arm and leg skin surface, socks, water resistant boots, chemical resistant gloves, and chemical resistant protective eyewear – splash goggles are recommended. When applying this product in confined spaces such as crawl spaces and attics, a ventilation exhaust system is recommended. If this is impractical, the use of a NIOSH approved respirator designed for dusts/mists is recommended. Clean spills and over-spray with a clean damp cloth or use an absorbent. Dispose of spill as required by state guidelines and laws.

**DIRECTIONS FOR USE:** It is a violation of Federal Law to use this product in a manner inconsistent with it's labeling. **Do not apply to foamboard.** Do not use in edible product areas of food processing plants or on counter tops and other surfaces where food is prepared. Do not use in serving areas where food is exposed. Do not contaminate feed, water or food. Do not use to treat lumber that will contact soil or be exposed to leaching by weather. Do not apply in classrooms when in use. Do not use in aircraft cabins. Do not apply to patient rooms in hospitals and nursing homes while occupied. Do not apply directly to food. In a non-federally inspected meat and poultry plant and food-processing establishment, the facility must not be in operation when this product is used. Exposed food should be covered or removed prior to the application. Thoroughly wash all food processing surfaces before reuse. After application in bakeries, meat packing plants, food processing plants, cafeterias, and similar facilities, wash all benches, shelving equipment etc. where exposed food will be handled with an effective cleaning compound followed by a potable water rinse to remove all traces of contamination.

This product cannot be tank mixed with other pesticide products. In the home, remove or cover exposed food, food handling surfaces, and cooking utensils. Wash thoroughly after treatment and before reuse. When spraying overhead interior areas of homes, apartments buildings, and all other dwellings, cover or protect all surfaces below the area being treated with plastic sheeting or other material which can be disposed of if contamination from dripping or splashing occurs. Use of this product does not substitute for mechanical alteration, soil treatment or foundation treatment, but is a supplement that is used as a preventative or remedial treatment to protect treated wood only.

### GENERAL INFORMATION

BoraSol Liquid is a water-soluble inorganic borate salt with termiticidal properties. BoraSol Liquid is effective for the protection and remedial treatment of wood against wood-destroying organisms, including the target pests listed below. This product can be used for remedial treatment of wood infested with target organisms, for preventative treatment of wood in existing structures (before signs of infestation), for pre-treatment of wood during construction, for the pressure treatment of lumber and for the dip-diffusion of lumber.

### TARGET ORGANISMS

BoraSol Liquid is effective for treatment of wood (and wood-foam composite structural components) against wood-infesting insects, including the following termites: Subterranean Termites - Reticulitermes, Heterotermes, Coptotermes (Formosan) / Dampwood Termites Zootermopsis

## This label is for End-Use Applications Only.

### WOOD

BoraSol Liquid is recommended for wood materials in accordance with the specific treatment methods described below. BoraSol Liquid is effective for interior and exterior wood (and wood-foam composite structural components) that will be protected from excessive rain and not in direct contact with soil. Types of wood include, but are not limited to, all types of lumber, logs, and plywood. This product is toxic to wood-destroying insects, but surface etching of treated wood may occur.

### **PREPARATION OF TREATMENT SOLUTION**

A 30% aqueous solution of BoraSol Liquid (15% Disodium Octaborate Tetrahydrate) is used for treatments. Please see table below for mixing instructions for various treatment areas.

#### **For Mixing 1:3 Mixing Ratio (One part BoraSol Liquid to 3 parts Water)**

1. Determine the number of gallons of 15% DOT solution to be prepared by first determining the number of square feet of wood to be treated and dividing by 200 sq ft/gal.
2. Using the table below, determine the appropriate size(s) of BoraSol Liquid product container(s) to use and choose the rinse volumes to be used.
3. Empty the contents of the container(s) into an appropriately sized mixing vessel.
4. Triple rinse the BoraSol Liquid container with the chosen amounts of rinse water from the table. Shake the rinses well to loosen and dissolve any residual BoraSol Liquid material and add to the mixing vessel. Use of hot water will hasten the dissolution process.
5. Mix the contents of the mixing vessel using an electric drill until the BoraSol Liquid is dissolved (warm water) or uniformly dispersed (cold water).

**Table of Mixing**

Summary of Mixing Instructions			
Volume of 15% DOT Solution (or 30% BoraSol Liquid)	1 gal RTU (200 sq ft)	2 gal RTU (400 sq ft)	4 gal RTU (800 sq ft)
BoraSol Liquid contents	2.8 lbs, 33 fl.oz., quart unit	5.6 lbs, 66 fl.oz., ½ gal unit	11.2 lbs, 132 fl.oz., gal unit
Volume of <u>Each of 3 Rinses</u>	0.25 gal OR	0.5 gal OR	1 gal OR
	32fl oz OR	64 fl oz OR	128 fl oz OR
	950 ml, 0.95 liters OR	1920ml, 1.9 liters OR	3840ml, 3.8 liters OR
	3.25" of water in the BoraSol Liquid container	6.5" of water in the BoraSol Liquid container	5" of water in the BoraSol Liquid container

## REMEDIAL TREATMENT

For remedial control of organisms attacking wood, apply the 30% aqueous solution of BoraSol Liquid by brush or spray until the surface is thoroughly wet (approximately 5 gallons per 1000 square feet or 500 linear feet). For adequate penetration, treatment should be conducted a second time after surface has dried. Treatment should include the crawl space, slab, basement, attic and all void constructions. Application may also be made by drilling and then injecting the solution under pressure into sound wood or until run-off is observed from entry/exit holes of infested wood. This product should be applied only to treat bare wood, plywood, and particleboard where an intact water repellent such as paint, stain, or a sealer is not present. Be sure to check the wood for structural integrity as this product does not enhance or provide structural integrity to treated wood. Do not use this product on wood in contact with the soil. Remedial treatment should result in a retention of 0.25 lb/ft<sup>3</sup> (4.0 kg/m<sup>3</sup>).

For treating infested wood thicker than one inch, you must inject the BoraSol Liquid solution into the wood in addition to spraying.

- Injection holes (1/8 inch in diameter) should be drilled in the area of suspected infestation. The holes should be drilled in a diamond pattern with the long axis along the grain and the holes spaced every 12 to 16 inches. Holes should be spaced 4 to 6 inches across the grain (see figure 1). When possible the wood should be treated one diamond pattern beyond the immediate area of visible infestation.
- Drill the holes through the widest dimension available. Do not drill completely through the beam, leave about 3/4 inch undrilled (See figure 1). If the widest surface is not accessible, holes can be drilled in the narrower surface. If the diamond pattern cannot be used. Drill holes 8-10 inches apart. All holes should no deeper than the injection tip. A longer injection tip should not be used (See Fig. 2).
- Press and hold the injection tip firmly into each hole and inject solution until runoff is observed from other holes, galleries, etc. When injecting solid wood maintain the injection pressure for 15 to 60 seconds at each hole. Longer times give better penetration.
- Release the trigger, wait briefly, and withdraw the injection tip. Excess solution can be absorbed with paper towels and collected for disposal.
- BoraSol Liquid solutions are compatible with stainless steel, brass and all plastic components of spray equipment.
- Equipment should be rinsed with clear water to flush remaining BoraSol Liquid out of equipment. The rinsate should be saved and treated as clean water to make up future BoraSol Liquid solutions or disposed in accordance with local regulations.

**Example: Treat an infestation in a structural beam with nominal 4x10 inch dimensions.**

- Each hole is drilled approximately 3.25" deep in the diamond pattern shown.
- Solution is injected under pressure for 15 seconds in each hole.
- If a gallery is directly penetrated, solution should be injected until runoff is detected from other holes. Wood surrounding the gallery should also be pressure injected. Treat "one diamond" length beyond the suspected area of infestation when possible.

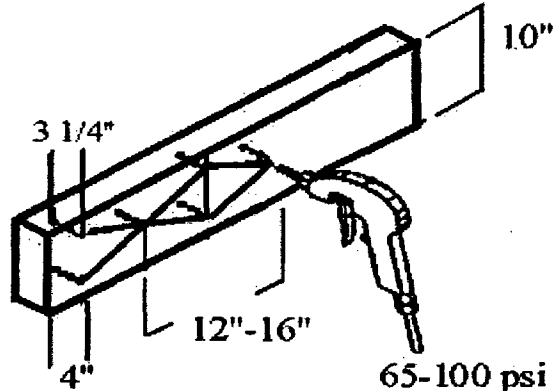

**Drill and pressure injection of a 4" x 10" structural beam**

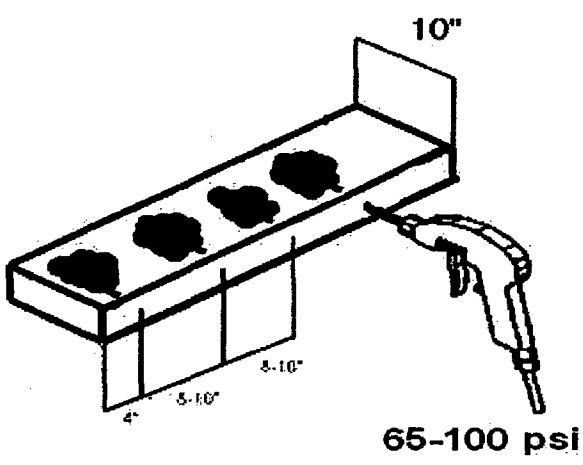

**Alternative pressure treatment of a 4" x 10" structural beam**

**PREVENTATIVE TREATMENT**

Spray applications of BoraSol Liquid may also be made to wood during construction. A 30% aqueous solution of BoraSol Liquid (15% Disodium Octaborate Tetrahydrate) is used for treatment. Please see table above for mixing instructions for various treatment areas.

Apply solution to all accessible surfaces of bare wood at a rate of approximately 5 gallons per 1000 square feet (500 linear feet). For adequate penetration, treatment should be conducted a second time after surface has dried. This should include all wood surfaces in crawl spaces and basements, to include all sills, plates, floor joists, piers, girders and sub floors as well as wood exposed to vertical access from the soil. Avoid spraying electrical components. Be sure electricity is turned off until solution is completely dry. Protect treated wood from excessive rain. Use of this product does not substitute for mechanical alteration, soil or foundation treatment, but is merely a supplement that is used as a preventative treatment to protect treated wood only.

**End cut treatment**

Certain pressure treated lumber should be treated when cut at a construction site because typical wood preservatives do not penetrate some wood species effectively. Spray, brush or dip the end-cuts over a plastic drop cloth to collect any runoff. Spray or brush generously until the wood will accept no more solution. Alternatively, dip each end-cut for about 5 minutes.

**Estimating amounts for application**

Calculating the amount of BoraSol Liquid to be used for a particular treatment is important. Approximately 1 gallon of BoraSol Liquid solution will be needed to treat 200 sq. ft. of wood surface area. You should always try to avoid extra, leftover solution. There are some predetermined factors which you can use as multipliers for given situations to calculate the square footage of wood to be treated. For example, if you had to spray a piece of wood that was 10 feet long and 6 inches wide, one side of the piece of wood will be 5 sq. ft. of wood surface area (10 ft x 0.5 ft. = 5 ft.<sup>2</sup>). If you spray all four sides once, the total square footage would be 20 ft.<sup>2</sup> requiring 0.1 gallons of solution.

When calculating square footage of wood surface area in a crawl space or basement, you have to consider all the wood present. The calculations are easily done. First, determine the square footage of the crawl area, by multiplying the length by the width, i.e., a 20 ft. x 40 ft. crawl space is 800 sq. ft. Multiply this by 2.5 and the result is an approximation of the total square footage of wood surface area for all the wood in the crawl space. Therefore, a 20 ft. x 40 ft. crawl area would be 2000 sq. ft. needing 10 gallons of BoraSol Liquid solution for one application.

In estimating the amount for a preventative treatment, there are many sections to consider: attics, interior walls, exterior walls and flooring. The guideline to use here is to obtain the square footage for the living area of the structure from the builder and multiply by 9. If a crawl space or basement is involved, then use the calculations above and add that number to the amounts calculated here. For example, the structure to be treated will be 2000 sq. ft. and have a 20 ft. x 40 ft. crawl space. Wood surface area is 2000 multiplied by 9, equaling 18000 sq. ft. Add the 2000 sq. ft. for the crawls space to get 20,000 sq. ft. of wood surface to be treated. This is 100 gallons of BoraSol Liquid solution per application.

**PRESSURE TREATMENT OF WOOD**

Pressure treatment of wood should result in a retention of 0.25 lb/ft<sup>3</sup> (4.0 kg/m<sup>3</sup>) DOT (equiv.) in the assay zone specified in AWWA standard C-2. The concentration of the solution must be adjusted to give the correct retention for wood species and size being treated; in general, solutions are in the range of 1-2% DOT (equiv.) (0.083-0.166 lb/gal) w/v. Standards C-1 and C-2 of the American Wood Preservers' Association should be consulted regarding treatment times, pressures and temperatures necessary for various species of wood.

Clean wood should be cut to dimension, dried to less than 25% moisture (as oven dry weight), stickered before treating. If several species are being treated at the same time, the treatment schedule should be chosen for the most difficult species to treat. If both sapwood and heartwood are included, use the schedule for heartwood to ensure adequate loadings.

## DIP-DIFFUSION TREATMENT

**PREPARATION OF SOLUTIONS:** To prepare solutions, described below, water should be added to the tank to about 80% of the volume of solution required. The temperature is then raised to the desired level and the calculated amount of BoraSol Liquid is gradually added with good agitation. The remaining water is then added and the solution agitated for an additional 10 minutes to insure that the product has dissolved. The temperature of the solution should be maintained during treatment. Upon cooling some BoraSol Liquid may crystallize out of the solution, but will re-dissolve when the solution is heated for the next treatment session. In very cold weather, some heating or insulation should be provided to prevent solidification in the bottom of the tank. The tank should be covered when not in use to prevent contamination and evaporation of water.

**Conditions and Solution Strengths for the Dip-Diffusion Method**

Lumber Thickness	Pounds of BoraSol Liq. Per Gallon of Water	Gallons BoraSol Liq.	Pounds of DOT (equiv.)	DOT (equiv.) Solution Conc.	Solution Temp.	Time of Diffusion
Up to 1 inch (2.5 cm)	4.0	0.40	2.0	16.2%	105°F (40°C)	2 to 4 weeks
1 to 1.75 in. (2.5 to 4.0 cm)	6.0	0.60	3.0	21.0%	120°F (50°C)	4 to 6 weeks
1.75 to 2.5 in. (4.0 to 6.5 cm)	12.0	1.2	6.0	29.6%	130°F (55°C)	4 to 6 weeks
2.5 to 3 in.* (6.5 to 7.5 cm)	15.0	1.5	7.5	32.2%	135°F (57°C)	6 to 8 weeks

- Lumber over 3 inches (7.5 cm) in thickness or over 5 inches (12.5 cm) in width should be dipped twice 24 to 72 hours apart.

**DIP-DIFFUSION METHOD OF APPLICATION:** Dip freshly cut lumber in a tank containing a hot aqueous solution of BoraSol Liquid for 2 to 5 minutes. After dipping, the newly treated wood should be stacked and stored under a tarpaulin or shed roof to slow the drying process and prevent wash-off by rainfall, thus improving penetration. Diffusion of the wood preservative into the interior of the wood will start immediately and will require several weeks to thoroughly penetrate the lumber, depending on species and thickness of wood. The dip-diffusion of lumber should result in a retention of 0.25 lbs/ft<sup>3</sup> (4.0 kg/m<sup>3</sup>) DOT (equiv.)



**ENVIRONMENTAL HAZARDS**

Do not discharge effluent containing this product into lakes, streams, ponds, estuaries, oceans or other water unless in accordance with the requirements of a National Pollutant Discharge Elimination System (NPDES) permit and the permitting authority has been notified in writing prior to discharge. Do not discharge effluent containing this product to sewer systems without previously notifying the local sewage treatment plant authority. For guidance contact your State Water Board or Regional Office of the EPA.

**STORAGE AND DISPOSAL**

Do not contaminate water, food, or feed by storage or disposal.

**STORAGE:** Store in a dry place. Do not store where children or animals may gain access.

**PESTICIDE DISPOSAL:** Wastes resulting from the use of this product may be disposed of on site or at an approved waste disposal facility.

**CONTAINER DISPOSAL:** Non-refillable container. Do not reuse or refill this container. Triple rinse container (or equivalent) promptly after emptying. Triple rinse as follows: Empty the remaining contents into application equipment or a mix tank and drain for 10 seconds after the flow begins to drip. Fill the container ¼ full with water and recap. Shake for 10 seconds. Pour rinsate into application equipment or a mix tank or store rinsate for later use or disposal. Drain for 10 seconds after the flow begins to drip. Repeat this procedure two more times. Offer for recycling if available or puncture and dispose of rinsed container in a sanitary landfill, or by other procedures approved by state and local authorities.

**NOTICE**

To the extent consistent with applicable law, neither manufacturer nor seller shall be liable in respect to any injury or damage suffered by reason of the use of this product for a purpose not indicated by the label or when used contrary to the directions or instructions hereon nor with respect to breach of any warranty not expressly specified herein. To the extent consistent with applicable law, buyer accepts this material subject to these terms, and assumes all risk of usage and handling except when used or handled in accordance with this label. For active termite infestations, get a professional inspection.