

69529-3

09/29/2004

1/10

Please read instructions on reverse before completing form.

Form Approved, OMB No. 2070-0060, Approval expires 2-28-95



United States
Environmental Protection Agency
Washington, DC 20460

Registration
 Amendment
 Other

OPP Identifier Number

Application for Pesticide - Section I

1. Company/Product Number Quality Borate Co. / 69529-3	2. EPA Product Manager Richard Gepken / 10	3. Proposed Classification <input type="checkbox"/> None <input type="checkbox"/> Restricted
4. Company/Product (Name) Quality Borate Co. / BoraSol Liquid	PM# 10	
5. Name and Address of Applicant (Include ZIP Code) Quality Borate Co. 3690 Orange Place, Ste. 480 Cleveland, OH 44122 <input type="checkbox"/> Check if this is a new address	6. Expedited Review. In accordance with FIFRA Section 3(c)(3) (b)(i), my product is similar or identical in composition and labeling to: EPA Reg. No. _____ Product Name _____	

Section - II

<input type="checkbox"/> Amendment - Explain below.	<input checked="" type="checkbox"/> Final printed labels in response to Agency letter dated _____	NOTIFICATION SEP 29 2004
<input type="checkbox"/> Resubmission in response to Agency letter dated _____	<input type="checkbox"/> "Me Too" Application.	
<input checked="" type="checkbox"/> Notification - Explain below.	<input type="checkbox"/> Other - Explain below.	

Explanation: Use additional page(s) if necessary. (For section I and Section II.)

In accordance with PR Notice 98-10, the purpose of this notification is to add the pests, "powderpost beetles, carpenter ants and wood decay fungi" to the label. Five copies of the new label with the primary brand name. This notification is consistent with the provisions of PR Notice 98-10 and EPA regulations at 40 CFR 152.46, and no other changes have been made to the labeling or the confidential statement of formula of this product. I understand that it is a violation of 18 U.S.C. Sec. 1001 to willfully make any false statement to EPA. I further understand that if this notification is not consistent with the terms of PR Notice 98-10 and 40 CFR 152.46, this product may be in violation of FIFRA and I may be subject to enforcement action and penalties under sections 12 and 14 of FIFRA."

Section - III

1. Material This Product Will Be Packaged In:

Child-Resistant Packaging <input type="checkbox"/> Yes <input checked="" type="checkbox"/> No	Unit Packaging <input type="checkbox"/> Yes <input checked="" type="checkbox"/> No	Water Soluble Packaging <input type="checkbox"/> Yes <input checked="" type="checkbox"/> No	2. Type of Container <input type="checkbox"/> Metal <input checked="" type="checkbox"/> Plastic <input type="checkbox"/> Glass <input type="checkbox"/> Paper <input type="checkbox"/> Other (Specify) _____
* Certification must be submitted		If "Yes" Unit Packaging wgt. No. per container	If "Yes" Package wgt. No. per container

3. Location of Net Contents Information
 Label Container

4. Size(s) Retail Container
1 gallon, 2.5 gallon, 5 gallon

5. Location of Label Directions
 front and back

6. Manner in Which Label is Affixed to Product
 Lithograph Paper glued Other _____
 Stenciled

Section - IV

1. Contact Point (Complete items directly below for identification of individual to be contacted, if necessary, to process this application.)

Name Kevin R. Kutcel	Title Technical Manager	Telephone No. (Include Area Code) 216-896-1990
-------------------------	----------------------------	---

Certification
I certify that the statements I have made on this form and all attachments thereto are true, accurate and complete. I acknowledge that any knowingly false or misleading statement may be punishable by fine or imprisonment or both under applicable law.

6. Date Application Received (Stamped)

2. Signature 	3. Title Technical Manager
4. Typed Name Kevin R. Kutcel	5. Date 9/17/04

SIG

2/10

NOTIFICATION

SEP 29 2004

BoraSol Liquid

Manufactured by: Quality Borate Co., 3690 Orange Place, #495
Cleveland, OH 44122

Phone: 1-866-BORATES (866-267-2837)

FOR PROTECTION AND PREVENTATIVE TREATMENT OF WOOD AGAINST TERMITES, REMEDIAL CONTROL OF SUCH PESTS IN INFESTED WOOD, PRESSURE TREATMENT AND DIP-DIFFUSION TREATMENT.

ACTIVE INGREDIENT:

Disodium Octaborate Tetrahydrate (Na₂B₈O₁₁ • 4H₂O) ..50%

INERT INGREDIENTS:.....50%

EPA Reg. No. 69529-3 EPA Est. No. 68476-OH-003

**50 lbs. Net Weight
(10 lbs/gallon)**

KEEP OUT OF REACH OF CHILDREN

**Precautionary Statements:
Hazards to humans and domestic animals**

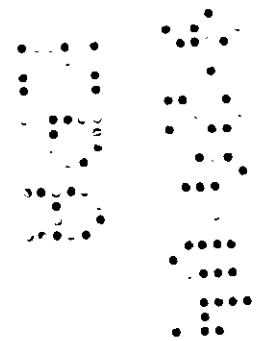

C A U T I O N

Harmful if swallowed. Avoid contact with eyes. Wash thoroughly after handling. Avoid contamination of food and feed. Do not leave container where children or animals may gain access. Have the product or label with you when calling a Poison Control Center or Doctor or going for treatment. In case of emergency, for additional information call (866-267-2837).

	FIRST AID
If swallowed	-Call poison control center or doctor immediately for treatment advice. -Have person sip a glass of water if able to swallow. -Do not induce vomiting unless told to do so by the poison control center or doctor. -Do not give anything by mouth to an unconscious person.
If in eyes	-Hold eye open and rinse slowly and gently with water for 15-20 minutes. -Remove contact lenses, if present, after the first 5 minutes, then continue rinsing eye. -Call a poison control center or doctor for treatment advice.
If on skin or clothing	- Rinse skin with plenty of water for 15-20 minutes. -Take off contaminated clothing. -Call poison control center or doctor for additional treatment advice.
If Inhaled	Move person to fresh air. -If person is not breathing, call 911 or an ambulance, then give artificial respiration, preferably by mouth-to-mouth, if possible -Call a poison control center or doctor for further advice.

Personal Protection Equipment

Applicators and other handlers must wear a long-sleeved shirt and long pants which cover the entire arm and leg skin surface, socks, water resistant boots, chemical resistant gloves, and chemical resistant protective eyewear – splash goggles are recommended. When applying this product in confined spaces such as crawl spaces and attics, a ventilation exhaust system is recommended. If this is impractical, the use of a NIOSH approved respirator designed for dusts/mists is recommended. Clean spills and over-spray with a clean damp cloth or use an absorbent. Dispose of spill as required by state guidelines and laws.

DIRECTIONS FOR USE: It is a violation of Federal Law to use this product in a manner inconsistent with it’s labeling. **Do not apply to foamboard.** Do not use in edible product areas of food processing plants or on counter tops and other surfaces where food is prepared. Do not use in serving areas where food is exposed. Do not contaminate feed, water or food. Do not use to treat lumber that will contact soil or be exposed to leaching by weather. Do not apply in classrooms when in use. Do not use in aircraft cabins. Do not apply to patient rooms in hospitals and nursing homes while occupied. Do not apply directly to food. In a non-federally inspected meat and poultry plant and food-processing establishment, the facility must not be in operation when this product is used. Exposed food should be covered or removed prior to the application. Thoroughly wash all food processing surfaces before reuse. After application in bakeries, meat packing plants, food processing plants, cafeterias, and similar facilities, wash all benches, shelving equipment etc. where exposed food will be handled with an effective cleaning compound followed by a potable water rinse to remove all traces of contamination.

This product cannot be tank mixed with other pesticide products. In the home, remove or cover exposed food, food handling surfaces, and cooking utensils. Wash thoroughly after treatment and before reuse. When spraying overhead interior areas of homes, apartments buildings, and all other dwellings, cover or protect all surfaces below the area being treated with plastic sheeting or other material which can be disposed of if contamination from dripping or splashing occurs. Use of this product does not substitute for mechanical alteration, soil treatment or foundation treatment, but is a supplement that is used as a preventative or remedial treatment to protect treated wood only.

GENERAL INFORMATION

BoraSol Liquid is a water-soluble inorganic borate salt with insecticidal properties. BoraSol Liquid is effective for the protection and remedial treatment of wood against wood-destroying organisms, including the target pests listed below. This product can be used for remedial treatment of wood infested with target organisms, for preventative treatment of wood in existing structures (before signs of infestation), for pre-treatment of wood during construction, for the pressure treatment of lumber and for the dip-diffusion of lumber.

TARGET ORGANISMS

BoraSol Liquid is effective for treatment of wood (and wood-foam composite structural components) against wood-infesting insects, including the following termites.

- | | |
|-------------------------------|----------------------------|
| Subterranean Termites | Powderpost Beetles |
| Reticulitermes, Heterotermes, | Lyctidae, Anobiids, |
| Coptotermes (Formosan) | Bostrichidae, Cerambycidae |
| Dampwood Termites | Carpenter Ants |
| Zootermopsis | Camponotus |
| | Wood Decay Fungi |

This label is for End-Use Applications Only.

WOOD

BoraSol Liquid is recommended for wood materials in accordance with the specific treatment methods described below. BoraSol Liquid is effective for interior and exterior wood (and wood-foam composite structural components) that will be protected from excessive rain and not in direct contact with soil. Types of wood include, but are not limited to, all types of lumber, logs, and plywood. This product is toxic to wood-destroying insects, but surface etching of treated wood may occur.

I. PREVENTATIVE TREATMENT FOR EXISTING STRUCTURE

Spray applications of BoraSol Liquid may also be made for existing structures. A 30% aqueous solution of BoraSol Liquid (15% Disodium Octaborate Tetrahydrate) is used for treatment. For example, to treat 200 square feet of surface area (100 linear feet), gradually mix 36 oz. of BoraSol Liquid (equivalent to 1.4 lbs of Disodium Octaborate Tetrahydrate) to 92 oz. of water to make a total solution of one gallon (8.8 lbs). Continue with agitation until the BoraSol Liquid has dissolved and the solution is completely clear. Please see table below for mixing instructions for various treatment areas.

Surface Area (sq. ft.)	100	200	600	800	2000	3000	5000
Linear Feet (2"x4" studs)	50	100	300	400	1000	1500	2500
Total Solution	½ gal.	1 gal.	3 gal.	4 gal.	10 gal.	15 gal.	25 gal.
Total Solution (lbs.)	4.4	8.8	26.4	35.2	88.0	132.0	220.0
BoraSol Liquid	18 oz.	36 oz.	108 oz.	144 oz.	2.8 gal.	4.2 gal.	7.0 gal.
BoraSol Liquid (lbs.)	1.4	2.8	8.4	11.2	28.0	42.0	70.0
Equiv. DOT (lbs.)	0.7	1.4	4.2	5.6	14.0	21.0	35.0
Water	46 oz.	92 oz.	2.2 gal.	2.9 gal.	7.2 gal.	10.8 gal.	18.0 gal.
Water (lbs.)	3.0	6.0	18.0	24.0	60.0	90.0	150.0

Apply solution to all accessible surfaces of bare wood at a rate of approximately 5 gallons per 1000 square feet (500 linear feet). For adequate penetration, treatment should be conducted a second time after surface has dried. This should include all wood surfaces in crawl spaces and basements, to include all sills, plates, floor joists, piers, girders and sub floors as well as wood exposed to vertical access from the soil. Avoid spraying electrical components. Be sure electricity is turned off until solution is completely dry. Protect treated wood from excessive rain. Use of this product does not substitute for mechanical alteration, soil or foundation treatment, but is merely a supplement that is used as a preventative treatment to protect treated wood only.

II. PRE-TREATMENT FOR WHOLE HOUSE PROTECTION

Spray applications of BoraSol Liquid may also be made to wood during new construction. A 30% aqueous solution of BoraSol Liquid (15% Disodium Octaborate Tetrahydrate) is used for treatment. For example, to treat 200 square feet of surface area (100 linear feet), gradually mix 36 oz. of BoraSol Liquid (equivalent to 1.4 lbs of Disodium Octaborate Tetrahydrate) to 92 oz. of water to make a total solution of one gallon (8.8 lbs). Continue with agitation until the BoraSol Liquid has dissolved and the solution is completely clear. Please see table below for mixing instructions for various treatment areas.

Surface Area (sq. ft.)	100	200	600	800	2000	3000	5000
Linear Feet (2"x4" studs)	50	100	300	400	1000	1500	2500
Total Solution	½ gal.	1 gal.	3 gal.	4 gal.	10 gal.	15 gal.	25 gal.
Total Solution (lbs.)	4.4	8.8	26.4	35.2	88.0	132.0	220.0
BoraSol Liquid	18 oz.	36 oz.	108 oz.	144 oz.	2.8 gal.	4.2 gal.	7.0 gal.
BoraSol Liquid (lbs.)	1.4	2.8	8.4	11.2	28.0	42.0	70.0
Equiv. DOT (lbs.)	0.7	1.4	4.2	5.6	14.0	21.0	35.0
Water	46 oz.	92 oz.	2.2 gal.	2.9 gal.	7.2 gal.	10.8 gal.	18.0 gal.
Water (lbs.)	3.0	6.0	18.0	24.0	60.0	90.0	150.0

A. Buildings on Crawl Spaces and Basements: Apply two (2) coats of BoraSol Liquid (1:1) solution to point of wetness in a 24-inch wide uninterrupted band to all wood surfaces in crawl spaces and basements, to include all sills, plates, floor joists, piers, girders and sub floors as well as wood exposed to vertical access from the soil. Treat any wood adjacent to plumbing, electrical conduit and ducts where they penetrate sub floors or plates, and all wood next to porches, garages, and fireplaces in order to provide a two (2) foot wide barrier of BoraSol Liquid treatment against termite penetration.

Wait at least 20 minutes between applications. If accessible, treat the exterior of sill areas around the entire perimeter of the structure with a 24-inch wide band of BoraSol Liquid solution beginning with the sill area and extending upwards onto the sheathing material.

On multiple story structures, treat only the first story above the masonry foundation level. Coated or painted wood may be treated by pressure injecting BoraSol Liquid into holes drilled into the wood at eight (8) to ten (10) inch intervals. Inject at 40 psi for four (4) to six (6) seconds per hole.

B. Buildings on Slabs: Apply two (2) coats of BoraSol Liquid solution to all base plates and the bottom 24 inches of all studs on all exterior and interior walls. Wait at least 20 minutes between applications. Treat all wood in plumbing walls and apply to any wood in bath traps as well as wood adjacent to plumbing, electrical conduit and duct penetrations in order to provide a minimum 24-inch wide barrier of treatment between the soil and the balance of the structure.

III. REMEDIAL TREATMENT FOR INFESTED WOOD

PREPARATION OF TREATMENT SOLUTION

A 30% aqueous solution of BoraSol Liquid (15% Disodium Octaborate Tetrahydrate) is used for treatment. For example, to treat 200 square feet of surface area (100 linear feet), gradually mix 36 oz. of BoraSol Liquid (equivalent to 1.4 lbs of Disodium Octaborate Tetrahydrate) to 92 oz. of water to make a total solution of one gallon (8.8 lbs). Continue with agitation until the BoraSol Liquid has dissolved and the solution is completely clear. Please see table below for mixing instructions for various treatment areas.

Surface Area (sq. ft.)	100	200	600	800	2000	3000	5000
Linear Feet (2"x4" studs)	50	100	300	400	1000	1500	2500
Total Solution	½ gal.	1 gal.	3 gal.	4 gal.	10 gal.	15 gal.	25 gal.
Total Solution (lbs.)	4.4	8.8	26.4	35.2	88.0	132.0	220.0
BoraSol Liquid	18 oz.	36 oz.	108 oz.	144 oz.	2.8 gal.	4.2 gal.	7.0 gal.
BoraSol Liquid (lbs.)	1.4	2.8	8.4	11.2	28.0	42.0	70.0
Equiv. DOT (lbs.)	0.7	1.4	4.2	5.6	14.0	21.0	35.0
Water	46 oz.	92 oz.	2.2 gal.	2.9 gal.	7.2 gal.	10.8 gal.	18.0 gal.
Water (lbs.)	3.0	6.0	18.0	24.0	60.0	90.0	150.0

REMEDIAL APPLICATION OF SOLUTION FOR EXISTING STRUCTURES

Infested Wood can be treated by spraying, injecting, or brushing a 30% aqueous solution of BoraSol Liquid by brush or spray until surface is thoroughly wet (approximately 5 gallons per 1000 square feet or 500 linear feet). For adequate penetration, treatment should be conducted a second time after surface has dried. Treatment should include the crawl space, slab, basement, attic and all void constructions. Application may also be made by drilling and then injecting the solution under pressure into sound wood or until run-off is observed from entry/exit holes of infested wood. This product should be applied only to treat bare wood, plywood, and particleboard where an intact water repellent such as paint, stain, or a sealer is not present. Be sure to check the wood for structural integrity as this product does not enhance or provide structural integrity to treated wood. Do not use this product on wood in contact with the soil. Remedial treatment should result in a retention of 0.25 lb/ft³ (4.0 kg/m³).

For treating infested wood thicker than one inch, you must inject the BoraSol Liquid solution into the wood in addition to spraying.

- Injection holes (1/8 inch in diameter) should be drilled in the area of suspected infestation. The holes should be drilled in a diamond pattern with the long axis along the grain and the holes spaced every 12 to 16 inches. Holes should be spaced 4 to 6 inches across the grain (see figure 1). When possible the wood should be treated one diamond pattern beyond the immediate area of visible infestation.
- Drill the holes through the widest dimension available. Do not drill completely through the beam, leave about ¼ inch undrilled (See figure 1). If the widest surface is not accessible, holes can be drilled in the narrower surface. If the diamond pattern cannot be used. Drill holes 8-10 inches apart. All holes should no deeper than the injection tip. A longer injection tip should not be used (See Fig. 2).
- Press and hold the injection tip firmly into each hole and inject solution until runoff is observed from other holes, galleries, etc. When injecting solid wood maintain the injection pressure for 15 to 60 seconds at each hole. Longer times give better penetration.

- Release the trigger, wait briefly, and withdraw the injection tip. Excess solution can be absorbed with paper towels and collected for disposal.
- BoraSol Liquid solutions are compatible with stainless steel, brass and all plastic components of spray equipment.
- Equipment should be rinsed with clear water to flush remaining BoraSol Liquid out of equipment. The rinsate should be saved and treated as clean water to make up future BoraSol Liquid solutions or disposed in accordance with local regulations.

Example: Treat an infestation in a structural beam with nominal 4x10 inch dimensions.

- Each hole is drilled approximately 3.25" deep in the diamond pattern shown.
- Solution is injected under pressure for 15 seconds in each hole.
- If a gallery is directly penetrated, solution should be injected until runoff is detected from other holes. Wood surrounding the gallery should also be pressure injected. Treat "one diamond" length beyond the suspected area of infestation when possible.

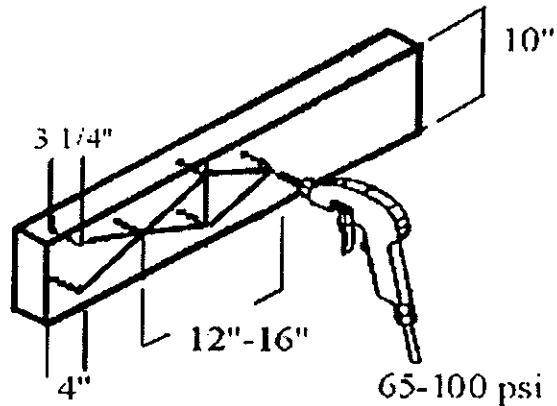

Drill and pressure injection of a 4" x 10" structural beam

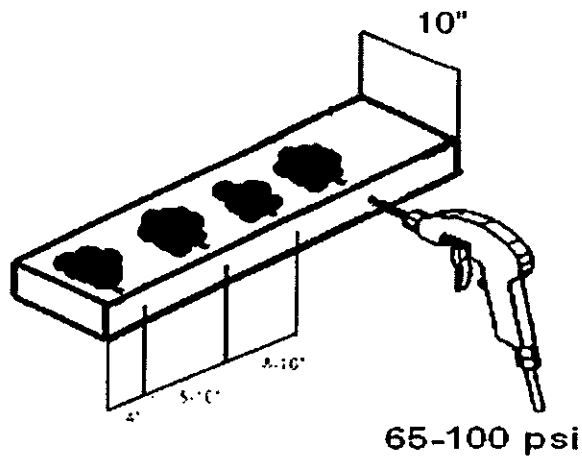

Alternative pressure treatment of a 4" x 10" structural beam

- A. Basements and crawl spaces** may be treated by applying BoraSol Liquid solution to the point of wetness to all infested and susceptible wood surfaces including sill plates, piers, girders, sub-floors, floor joists and any wood exposed to vertical access from the soil. A second coat of BoraSol Liquid should be applied for adequate protection. Wait at least 20 minutes between applications. Apply at a rate of approximately one (1) gallon of BoraSol Liquid solution per 200 square feet of floor area.
- B. Buildings on slabs** may be treated by applying a 30% BoraSol Liquid solution into wall voids by locating each stud and drilling a small hole through the wall covering to gain access to the infested area. Drill holes adjacent to the side of each stud every 18-24 inches along its length and inject at least 1/3 fluid ounce of BoraSol Liquid solution per hole. Drill at least one hole per stud bay near the floor in order to treat the base plate in each void. Treat entire wall areas as opposed to single stud bays in order to include the infested area completely within the treatment zone. A second treatment application is required to assure adequate protection.
- C. Wood flooring** can be treated by spray, brush or roller application. It will be necessary to remove any existing finish by complete coarse sanding or stripping prior to application. Apply a 30% BoraSol Liquid solution at a rate of approximately one (1) gallon of solution per 200 square feet of floor surface. For adequate protection, two (2) coats may be required, waiting at least one (1) hour between applications. Allow floor to completely dry (typically 48 to 72 hours). Moisture content must be 10% or less before applying final finish. BoraSol Liquid applications may raise the grain of the wood and an additional light sanding may be necessary before applying a new finish. Although BoraSol Liquid is compatible with most floor coatings, always test a small section of treated floor with the new finish and check for appropriate adhesion prior to coating the entire floor. NOTE: If residue is evident after 72 hours of drying time, wash affected area with clean water and a mop, cloth, or sponge, rinsing frequently. Allow surface to dry prior to final light sanding and application of finish coat.

End cut treatment

Certain pressure treated lumber should be treated when cut at a construction site because typical wood preservatives do not penetrate some wood species effectively. Spray, brush or dip the end-cuts over a plastic drop cloth to collect any runoff. Spray or brush generously until the wood will accept no more solution. Alternatively, dip each end-cut for about 5 minutes.

Estimating amounts for application

Calculating the amount of BoraSol Liquid to be used for a particular treatment is important. Approximately 1 gallon of BoraSol Liquid solution will be needed to treat 200 sq. ft. of wood surface area. You should always try to avoid extra, leftover solution. There are some predetermined factors which you can use as multipliers for given situations to calculate the square footage of wood to be treated. For example, if you had to spray a piece of wood that was 10 feet long and 6 inches wide, one side of the piece of wood will be 5 sq. ft. of wood surface area ($10 \text{ ft} \times 0.5 \text{ ft} = 5 \text{ ft.}^2$). If you spray all four sides once, the total square footage would be 20 ft.^2 requiring 0.1 gallons of solution.

When calculating square footage of wood surface area in a crawl space or basement, you have to consider all the wood present. The calculations are easily done. First, determine the square footage of the crawl area, by multiplying the length by the width, i.e., a 20 ft. x 40 ft. crawl space is 800 sq. ft. Multiply this by 2.5 and the result is an approximation of the total square

footage of wood surface area for all the wood in the crawl space. Therefore, a 20 ft. x 40 ft. crawl area would be 2000 sq. ft. needing 10 gallons of BoraSol Liquid solution for one application.

In estimating the amount for a preventative treatment, there are many sections to consider: attics, interior walls, exterior walls and flooring. The guideline to use here is to obtain the square footage for the living area of the structure from the builder and multiply by 9. If a crawl space or basement is involved, then use the calculations above and add that number to the amounts calculated here. For example, the structure to be treated will be 2000 sq. ft. and have a 20 ft. x 40 ft. crawl space. Wood surface area is 2000 multiplied by 9, equaling 18000 sq. ft. Add the 2000 sq. ft. for the crawls space to get 20,000 sq. ft. of wood surface to be treated. This is 100 gallons of BoraSol Liquid solution per application.

PRESSURE TREATMENT

Pressure treatment of wood should result in a retention of 0.25 lb/ft³ (4.0 kg/m³) DOT (equiv.) in the assay zone specified in AWWA standard C-2. The concentration of the solution must be adjusted to give the correct retention for wood species and size being treated; in general, solutions are in the range of 1-2% DOT (equiv.) (0.083-0.166 lb/gal) w/v. Standards C-1 and C-2 of the American Wood Preservers' Association should be consulted regarding treatment times, pressures and temperatures necessary for various species of wood.

Board Feet	500	1000	2000	3000	5000	10,000
Wood (cubic feet)	41.7	83.3	166.7	250.0	416.7	833.3
Water (gallons)	62.7	125.4	250.8	376.2	627.0	1,254.0
Water (lbs)	520.4	1,040.8	2,081.6	3,122.5	5,204.1	10,408.2
BoraSol Liquid (gal.)	2.1	4.2	8.3	12.5	20.8	41.6
BoraSol Liquid (lbs)	21.0	42.0	84.0	126.0	210.0	420.0
Equiv. DOT (lbs)	10.5	21.0	42.0	63.0	105.0	210.0

Clean wood should be cut to dimension, dried to less than 25% moisture (as oven dry weight), stickered before treating. If several species are being treated at the same time, the treatment schedule should be chosen for the most difficult species to treat. If both sapwood and heartwood are included, use the schedule for heartwood to ensure adequate loadings.

DIP-DIFFUSION TREATMENT

PREPARATION OF SOLUTIONS: To prepare solutions, described below, water should be added to the tank to about 80% of the volume of solution required. The temperature is then raised to the desired level and the calculated amount of BoraSol Liquid is gradually added with good agitation. The remaining water is then added and the solution agitated for an additional 10 minutes to insure that the product has dissolved. The temperature of the solution should be maintained during treatment. Upon cooling some BoraSol Liquid may crystallize out of the solution, but will re-dissolve when the solution is heated for the next treatment session. In very cold weather, some heating or insulation should be provided to prevent solidification in the bottom of the tank. The tank should be covered when not in use to prevent contamination and evaporation of water.

Conditions and Solution Strengths for the Dip-Diffusion Method

Lumber Thickness	Pounds of BoraSol Liq. Per Gallon of Water	Gallons BoraSol Liq.	Pounds of DOT (equiv.)	DOT (equiv.) Solution Conc.	Solution Temp.	Time of Diffusion
Up to 1 inch (2.5 cm)	4.0	0.40	2.0	16.2%	105°F (40°C)	2 to 4 weeks
1 to 1.75 in. (2.5 to 4.0 cm)	6.0	0.60	3.0	21.0%	120°F (50°C)	4 to 6 weeks
1.75 to 2.5 in. (4.0 to 6.5 cm)	12.0	1.2	6.0	29.6%	130°F (55°C)	4 to 6 weeks
2.5 to 3 in.* (6.5 to 7.5 cm)	15.0	1.5	7.5	32.2%	135°F (57°C)	6 to 8 weeks

* Lumber over 3 inches (7.5 cm) in thickness or over 5 inches (12.5 cm) in width should be dipped twice 24 to 72 hours apart.

DIP-DIFFUSION METHOD OF APPLICATION: Dip freshly cut lumber in a tank containing a hot aqueous solution of BoraSol Liquid for 2 to 5 minutes. After dipping, the newly treated wood should be stacked and stored under a tarpaulin or shed roof to slow the drying process and prevent wash-off by rainfall, thus improving penetration. Diffusion of the wood preservative into the interior of the wood will start immediately and will require several weeks to thoroughly penetrate the lumber, depending on species and thickness of wood. The dip-diffusion of lumber should result in a retention of 0.25 lbs/ft³ (4.0 kg/m³) DOT (equiv.)

ENVIRONMENTAL HAZARDS

Do not discharge effluent containing this product into lakes, streams, ponds, estuaries, oceans or other water unless in accordance with the requirements of a National Pollutant Discharge Elimination System (NPDES) permit and the permitting authority has been notified in writing prior to discharge. Do not discharge effluent containing this product to sewer systems without previously notifying the local sewage treatment plant authority. For guidance contact your State Water Board or Regional Office of the EPA.

STORAGE AND DISPOSAL

Do not contaminate water, food, or feed by storage or disposal.

STORAGE: Store in a dry place. Do not store where children or animals may gain access.

PESTICIDE DISPOSAL: Wastes resulting from the use of this product may be disposed of on site or at an approved waste disposal facility.

CONTAINER DISPOSAL: Completely empty bag into application equipment. Then dispose of empty bag in a sanitary landfill or by incineration, or if allowed by state and local authorities by burning. If burned, stay out of smoke.

NOTICE

Neither manufacturer nor seller shall be liable in respect to any injury or damage suffered by reason of the use of this product for a purpose not indicated by the label or when used contrary to the directions or instructions hereon nor with respect to breach of any warranty not expressly specified herein. Buyer accepts this material subject to these terms, and assumes all risk of usage and handling except when used or handled in accordance with this label. For active termite infestations, get a professional inspection.