

67712-1

10-16-2003

1/26

UNITED STATES ENVIRONMENTAL PROTECTION AGENCY

OCT 16 2003

Sally Hayes, Agent For Zodiac Pool Care  
c/o Scientific & Regulatory Consultants, Inc.  
P.O. Box 1014  
Columbia City, IN 46725

**Subject: Nature 2 G45-VC40  
EPA Reg. No. 67712-1  
Your Notification Dated 9/30/03**

The notification referred to above, submitted in connection with registration under the Federal Insecticide, Fungicide, and Rodenticide Act, as amended, to add the additional brand name of "DuoClear Cartridge", and to make additional non-pesticidal labeling changes allowed by PR Notice 98-10 to both the carton label and owners manual, is acceptable.

Your notification has been made a part of the permanent records for this file.

If you have any questions about the comments in this letter, please feel free to contact Tony Kish at 703-308-9443, or myself at 703-308-6341.

Sincerely,

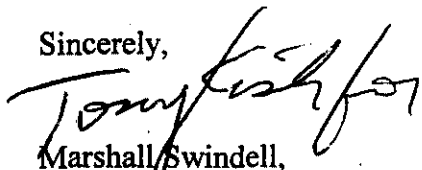

Marshall Swindell,  
Product Manager Team 33,  
Regulatory Management Branch I  
Antimicrobials Division (7510C)

CONCURRENCES

SYMBOL							
SURNAME							
DATE							

2/26



United States  
Environmental Protection Agency  
Washington, DC 20460

<input type="checkbox"/>	Registration
<input type="checkbox"/>	Amendment
<input checked="" type="checkbox"/>	Other

OPP Identifier Number

### Application for Pesticide - Section I

1. Company/Product Number 67712-1	2. EPA Product Manager M. Swindell	3. Proposed Classification <input checked="" type="checkbox"/> None <input type="checkbox"/> Restricted
4. Company/Product (Name) Nature2® G45-VC40	PM# 33	
5. Name and Address of Applicant (Include ZIP Code) Zodiac Pool Care, Inc. 2028 N.W. 25th Avenue Pompano Beach, FL 33069 <input type="checkbox"/> Check if this is a new address	6. Expedited Review. In accordance with FIFRA Section 3(c)(3) (b)(i), my product is similar or identical in composition and labeling to: EPA Reg. No. _____ Product Name _____	

### Section - II

<input type="checkbox"/> Amendment - Explain below.	<input type="checkbox"/> Final printed labels in response to Agency letter dated _____
<input type="checkbox"/> Resubmission in response to Agency letter dated _____	<input type="checkbox"/> "Me Too" Application.
<input type="checkbox"/> Notification - Explain below.	<input type="checkbox"/> Other - Explain below.

**Explanation:** Use additional page(s) if necessary. (For section I and Section II.)

Notification to add an alternate brand name (DuoClear™ Cartridge) and additional labeling language per PR Notice 98-10. This notification is consistent with the provisions of PR Notice 98-10 and EPA regulations at 40 CFR 152.46, and no other changes have been made to the labeling or confidential statement of formula of this product. I understand that it is a violation of 18 U.S.C. Sec. 1001 to willfully make any false statement to EPA. I further understand that if this notification is not consistent with the terms of PR Notice 98-10 and 40 CFR 152.46, this product may be in violation of FIFRA and I may be subject to enforcement action and penalties under sections 12 and 14 of FIFRA.

### Section - III

1. Material This Product Will Be Packaged In:				2. Type of Container	
Child-Resistant Packaging <input type="checkbox"/> Yes <input type="checkbox"/> No	Unit Packaging <input type="checkbox"/> Yes <input type="checkbox"/> No	Water Soluble Packaging <input type="checkbox"/> Yes <input type="checkbox"/> No		<input type="checkbox"/> Metal	<input type="checkbox"/> Plastic
				<input type="checkbox"/> Glass	<input type="checkbox"/> Paper
* Certification must be submitted		If "Yes" Unit Packaging wgt.	No. per container	If "Yes" Package wgt.	No. per container
3. Location of Net Contents Information <input type="checkbox"/> Label <input type="checkbox"/> Container		4. Size(s) Retail Container		5. Location of Label Directions	
6. Manner in Which Label is Affixed to Product <input type="checkbox"/> Lithograph <input type="checkbox"/> Paper glued <input type="checkbox"/> Stenciled			<input type="checkbox"/> Other _____		

### Section - IV

1. Contact Point (Complete items directly below for identification of individual to be contacted, if necessary, to process this application.)		
Name Sally Hayes	Title Agent for Zodiac Pool Care, Inc.	Telephone No. (Include Area Code) 260-244-6270
2. Signature 		3. Title Agent for Zodiac Pool Care, Inc.
4. Typed Name Sally Hayes		5. Date 09/30/03
I certify that the statements I have made on this form and all attachments thereto are true, accurate and complete. I acknowledge that any knowingly false or misleading statement may be punishable by fine or imprisonment or both under applicable law.		6. Date Application Received (Stamped)

Nature<sup>2</sup> G45-VC40  
EPA Reg. No. 67712-1

Notification 093003

- Alternate Brand Name – DuoClear™ Cartridge
- Alternate labeling language

### CHANGES TO CARTON LABEL

LOCATION	CHANGE
Page 2	Added the text "Assembled in USA from components made in USA , China, and Australia"
Page 5	Added new part numbers "W20049", "W20050", and "W20051"
Page 3	Added a new pool graphic of the DuoClear installation
Page 5	Added part numbers
Page 8	Add optional language "Inground and Aboveground"
Page 11	Added chart to show consumer what cartridge to use in their vessel and other related language
Page 11	Added DuoClear chart, associated language and text for cartridge stickers
Page 12	Added a graphic of the DuoClear cartridge

### CHANGES TO OWNER'S MANUAL

LOCATION	CHANGE
Global	Use of the phrase "Zodiac dealer" as an optional replacement for "Nature2 dealer"
Page 2	Changed ""Zeneca" to "Avecia"
Page 4	Changed administrative language
Page 6	Added the text "Monitor the cartridge replacement light on the DuoClear control panel" in the Cartridge Replacement Intervals section
Page 7	Revised the Limited Warranty section to include "Nature <sup>2</sup> " as an alternative
Page 7 & 8	Included the optional pool capacity "10,000 to 45,000 gallons"
Page 8	Added the text "Features Nature <sup>2</sup> Technology"
Page 8	Added the text "with Nature2 Technology"
Page 8	Added cartridge capacity chart

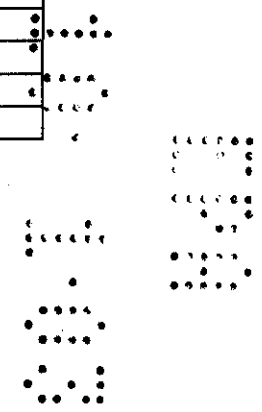

4/26

ACTIVE INGREDIENTS:

Metallic Silver**	3.51%
Copper Sulfate pentahydrate***	8.23%
TOTAL	100.00%

\*\*From Silver Nitrate  
 \*\*\* Copper (Cu) as metallic ... 2.0%

\*The Nature<sup>2</sup> System consists of the patented Nature<sup>2</sup> technology used in conjunction with a chlorine delivery device or 0.5ppm of an EPA registered chlorine pool product.  
 † Nature<sup>2</sup> technology consists of the minerals silver and copper.

EPA Reg. No. 67712-1

EPA Est. No. 67712-FL-001

**KEEP OUT OF REACH OF CHILDREN**

**CAUTION**

SEE BACK PANEL FOR ADDITIONAL PRECAUTIONARY STATEMENTS



**ZODIAC**



**Nature<sup>2</sup>® G45-VC40**



**The Mineral Cartridge**

the Low Chlorine Alternative

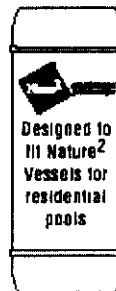

NET CONTENTS: {ONE CARTRIDGE} [ONE UNIT]

8/26

{language on this page is required on all carton labels}

CHANGE THIS CARTRIDGE EVERY [SIX] [FOUR] MONTHS {may appear on any panel}  
Use of this cartridge [for] longer than [four] [six] continuous months will void the warranty. Discard [the] [this] cartridge at the end of [six] [four] months. {may appear on any panel}

**PRECAUTIONARY STATEMENT**  
**Hazards to Humans and Domestic Animals**

**Caution**

In the unlikely event that a cartridge breaks, mineral media should not be ingested by humans or animals as it may cause gastric distress.

**FIRST AID**

IF INGESTED: Call poison control center or doctor immediately for treatment advice.

**DISPOSAL**

After [six] [four] months of use, discard cartridge in household trash. Do not save the cartridge for re-use. The cartridge is manufactured with the mineral media sealed inside. In the unlikely event a cartridge breaks, remove it [the cartridge] and vacuum out any media introduced into the pool [water].

**DIRECTIONS FOR USE**

It is a violation of Federal Law to use this product in a manner inconsistent with its labeling.

See owner's manual inside box for directions for use.



Zodiac Pool Care, Inc.  
2028 NW 25<sup>th</sup> Avenue  
Pompano Beach, FL 33069

© 2002 Zodiac Pool Care, Inc.

Member



Assembled in USA from components made in USA, China and Australia

6/26

{language/pictures/diagrams on this page are optional and may appear on any panel of the carton label in any combination}

Compare the Difference! {photo dependent on model}

Conventionally chlorinated pool

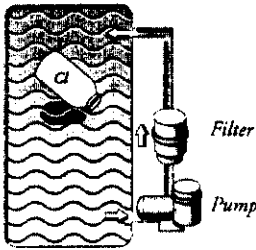

Nature<sup>2</sup> System<sup>™</sup> sanitized pool

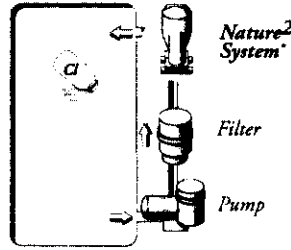

OR

Conventionally chlorinated pool

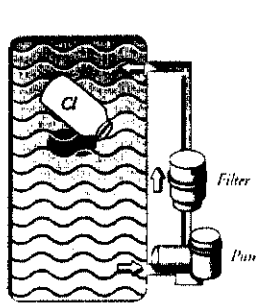

Nature<sup>2</sup> System<sup>™</sup> sanitized pool

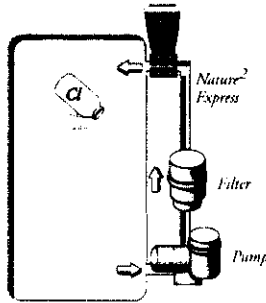

OR

Conventionally chlorinated pool

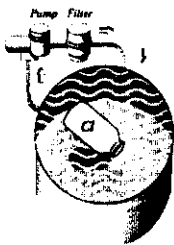

Nature<sup>2</sup> System<sup>™</sup> sanitized pool

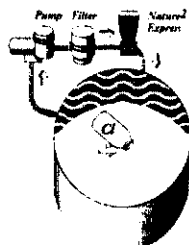

OR {the graphic below added on 9/26/03}

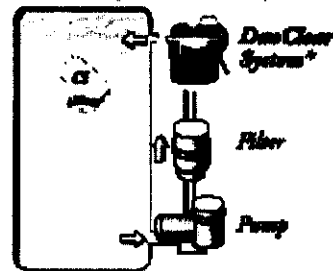
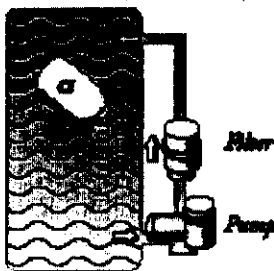

7/26

{language/pictures/diagrams on this page are optional and may appear on any panel of the carton label in any combination}

The Nature<sup>2</sup> System\* effectively sanitizes your pool.

- Destroys bacteria and algae growth
- Reduces chlorine use to just 0.5ppm
- Restores water clarity
- [For inground and aboveground pools with cartridge filters up to 25,000 gallons]
- Install in seconds [- lasts [six] [four] months]
- [Mineral cartridge] Lasts [six] [four] months

It's Nature<sup>2</sup> Technology. †

["Product name" features] Nature<sup>2</sup> technology [which] is an effective process that sanitizes pool water using minerals and just 0.5ppm chlorine.

To keep your patented Nature<sup>2</sup> Sanitizer operating properly, it is necessary to change this cartridge every [six] [four] months.

The Nature<sup>2</sup> System\* improves water quality.

- The Nature<sup>2</sup> System\* is an exclusive patented mineral technology. †
- [Lower chlorine levels] help[s] keep [the] pool pH balanced.
- Simply replace the cartridge every [six] [four] months.

Nature<sup>2</sup>® water is brilliantly clear and soft

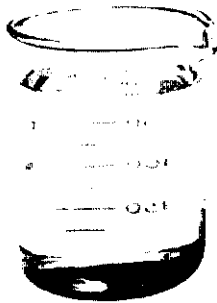

Enhanced swimmer comfort.

- Reduces potential for stinging eyes, skin irritation and unpleasant odors.

Will not damage your pool equipment.

Satisfaction guaranteed.

It's compatible.

- Compatible with most pool maintenance products.\*\*\*\*
- Will not damage your pool equipment.

\*\*\*\* Do not use [this product] [Nature<sup>2</sup>] with copper-based algaecides, bromine or bromide chemicals, or Biguanides (Baquacil®, SoftSwim®, Revacil®). Baquacil is a registered trademark of Zeneca Inc., SoftSwim is a registered trademark of Biolab, Inc. Revacil is a registered trademark of Mareva, Inc.

For Crystal Clear Water in All Types of Pools

8/26

{language/pictures/diagrams on this page are optional and may appear on any panel of the carton label in any combination}

{alternate optional language}

\_\_\_\_\_ VC40

\_\_\_\_\_ VC20

{Replace with the following}

[Nature<sup>2</sup> G Cartridge For 35,000-45,000 Gallon Inground Pools]

[Nature<sup>2</sup> G Cartridge For 25,000-35,000 Gallon Inground Pools]

[Nature<sup>2</sup> G Cartridge For 10,000-25,000 Gallon Inground Pools]

[Nature<sup>2</sup> M Cartridge For 5,000-25,000 Gallon Inground Pools]

[Nature<sup>2</sup> VC Cartridge For inground pools from 5,000-20,000 gallons]

[Nature<sup>2</sup> VC Cartridge] For inground pools from 20,000-40,000 gallons]

[Nature<sup>2</sup>] [G Cartridge] [M Cartridge] [and] [VC Cartridge] [CF] [Express] [Express Cartridge]

For [Aboveground] [and] [Inground] Pools [up to 25,000 Gallons]

{these part numbers may appear on the respective corresponding label}

[P/N] [W] [22325] [22330] [22335] [22340] [22345] [22350] [22355] [222360] [22380] [22385] [20055] [20065] [22375] [29550] [28125] [28126] [28135] [28136] [28145] [28146] [28155] [28175] [28185] [28195] [20171] [20080] [29500] [W20049] [W20050] [W20051]

{these are names of vessels ( housings) to help the consumer determine the correct cartridge for their system}

Nature<sup>2</sup>

Fits all Nature<sup>2</sup> [Professional G], [Premium M], [R] [A] Vessels

[(Except Nature<sup>2</sup> Limited)]

[Nature2, Vision, Claritec, Clear Vision, EcoSpring, Aquatech, Visipure, White River, Fafco, California, Hawaiian ]

{optional cartridge/corresponding vessel checkbox}

Cartridge	Corresponding Vessel
<input type="checkbox"/> G25 10,000 - 25,000 Gallons	Professional G Inground Vessel
<input type="checkbox"/> G35 25,000 - 35,000 Gallons	Professional G Inground Vessel
<input type="checkbox"/> G45 35,000 - 45,000 Gallons	Professional G Inground Vessel
<input type="checkbox"/> M25 5,000 - 25,000 Gallons	Premium M Inground Vessel
<input type="checkbox"/> A30 5,000 - 30,000 Gallons	A Aboveground Vessel

Made in [the] USA {NOTE: A picture of the US flag may also appear on some packages}

{The term "cartridge" or "this product" on this master label may be replaced with the product name on the marketing label}



9/26

{language/pictures/diagrams on this page are optional and may appear on any panel of the carton label in any combination}

{Additional optional language/graphics for Express model}

Easy do-it-yourself in-line installation, in minutes [(fits 1 1/2" and 2" rigid PVC pipe)] [includes adapter that fits most aboveground pools]

Just twist onto your existing Nature<sup>2</sup> Express Assembly

[REPLACEMENT CARTRIDGE FOR NATURE<sup>2</sup> EXPRESS] FOR [ABOVEGROUND] [AND] [INGROUND] POOLS

Installation is simple.

In just minutes you can install Nature<sup>2</sup> Express, activate the cartridge, and start enjoying a crystal clear Nature<sup>2</sup> pool. Nature<sup>2</sup> Express fits most aboveground [inground] pools up to 25,000 gallons [with 1 1/2" or 2" rigid PVC plumbing].

Nature<sup>2</sup> Express contains no moving parts and is unaffected by heavy use, hot weather and water temperature. You only have to change the replaceable cartridge every six months! Please refer to the operating manual for complete installation instructions.

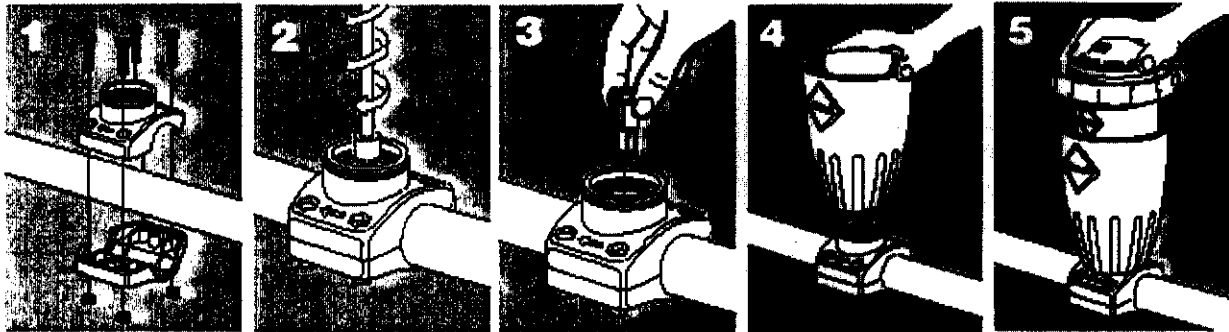

Turn pool pump off. Secure clamp assembly on the return line. [For aboveground pools with corrugated pipe, use PVC adapter provided.]

Cut hole in rigid PVC pipe using a power drill and the hole saw that is provided.

Insert the flow diverter into hole and snap it into place.

Snap dispenser shell onto clamp.

Thread the cartridge into the clamp, turn on pool pump and activate the cartridge. Refer to your cartridge owner's manual for start up instructions.

**PRODUCT SPECIFICATIONS**

Capacity	For 5,000 to 25,000 gallon pools
Cartridge Life	6 months
Run Time	6 hours a day minimum

**Installation Process:**

Please refer to the Nature<sup>2</sup> Express Operating Manual for installation instructions.

Refer to the Nature<sup>2</sup> Express Owner's manual for start-up instructions.

Installation of a Nature<sup>2</sup> Express replacement cartridge takes just minutes. First turn off the pool pump. Then simply remove the existing cartridge from your Nature<sup>2</sup> Express Sanitizer and replace it with your new cartridge.

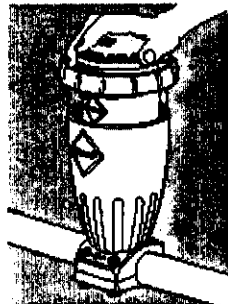

10/26

{language/pictures/diagrams on this page are optional and may appear on any panel of the carton label in any combination}

{Additional optional language/graphics for Express model}



The  
Mineral  
Pool Sanitizer  
The Low Chlorine Alternative

{Additional optional language/graphics for Nature<sup>2</sup> CF model}

FOR INGROUND AND ABOVEGROUND POOLS WITH CARTRIDGE FILTERS

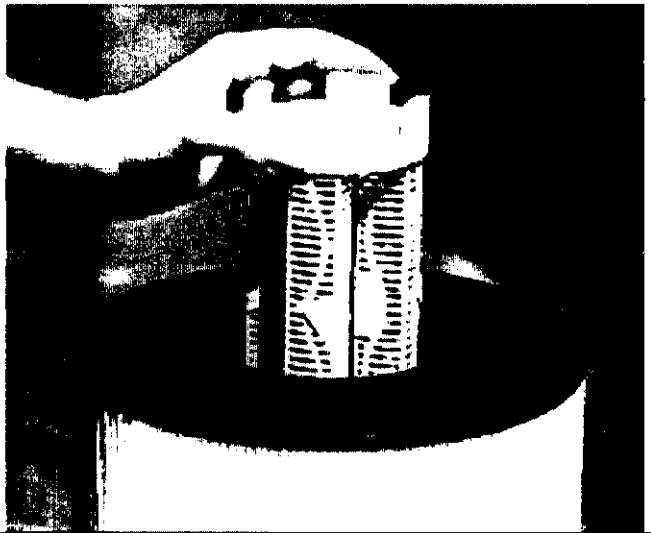

11/26

{language/pictures/diagrams on this page are optional and may appear on any panel of the carton label in any combination}

{Additional optional language/graphics for Hayward model}  
Hayward® Swimpure™



America's #1 Pool Water Systems  
Hayward Swimpure™

Pool Sanitizing System\* for Hayward [Inground and Aboveground] [Cartridge] [Top-Mount Sand] Filters

For Inground and Aboveground Pools [with cartridge filters]

Easily installs in your Hayward cartridge filter – no external canister required

No electricity, no moving parts...it's powered by water flow

For Inground and Aboveground Pools with [Cartridge] [Sand] Filters

- For inground ( up to 35,000 gallons)and aboveground (up to 25,000 gallons) pools with[sand] [cartridge] filters

Works on the following Hayward Cartridge Filters {filter names/model #/cartridge # may vary}

Hayward Filter	Hayward Filter Model #	Swimpure Cartridge #
Easy-Clear	C400	N2CN25
Easy-Clear	C550	N2CN25
ASL	C850	N2CN25
ASL	C1250	N2CW25
Star-Clear Plus	C751/900	N2CW25, N2CW35
Star-Clear Plus	C1200	N2CN25, N2CN35
Star-Clear Plus	C17502	N2CW25, N2CW35
Super Star-Clear/SwimClear	C2000/C2020	N2CN25, N2CN35
Super Star-Clear/SwimClear	C3000/C3020	N2CN25, N2CN35
Super Star-Clear/SwimClear	C4000/C4020	N2CN25, N2CN35
Super Star-Clear/SwimClear	C5000/C5020	N2CN25, N2CN35

{the following cartridge numbers may vary}

N2S25 (Hayward Top Mount IG or AG Sand Filters from 14" x 24" to 21" x 24")

N2S35 (Hayward Top Mount IG Sand Filters from 21" x 24")

12/26

{language/pictures/diagrams on this page are optional and may appear on any panel of the carton label in any combination}



Visit our website at [www.xxxx.xxx](http://www.xxxx.xxx)

[US Patent No. 6,004,458]  
[US Patent No. 6,254,788]  
[US Patent No. 6,287,462]

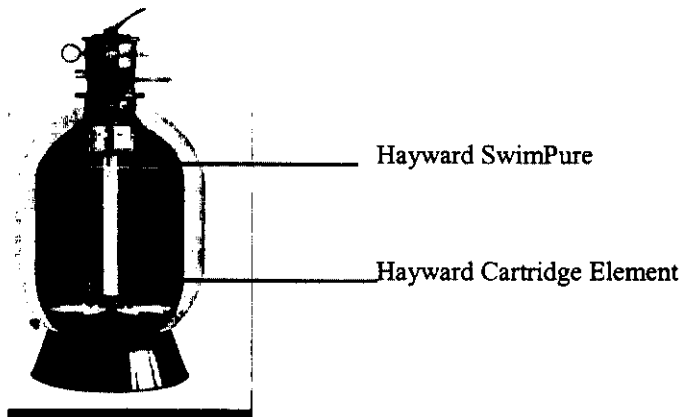
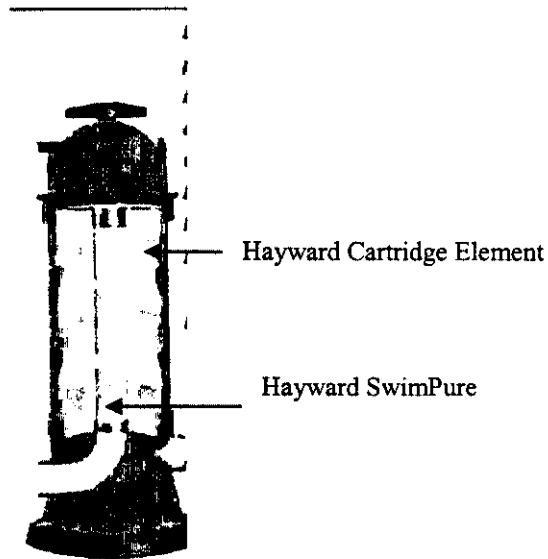

13/26

{language/pictures/diagrams on this page are optional and may appear on any panel of the carton label in any combination}

Debris in unfiltered pool water is trapped by the Hayward cartridge element. Filtered water then passes through the SwimPure Mineral Sanitizing System and re-enters the pool.

{optional graphic for the sand cartridge}

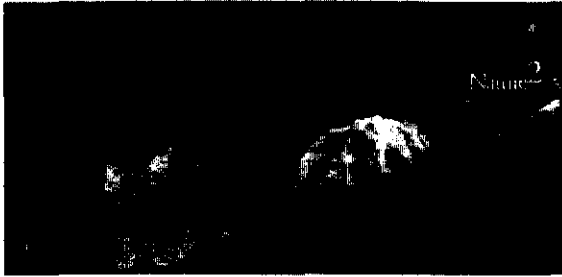
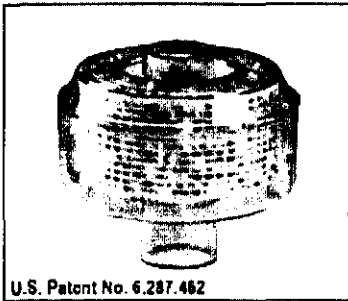

The Nature<sup>2</sup> logo is a registered trademark owned by Zodiac Pool Care, Inc.

©Hayward

14/26

{language/pictures/diagrams on this page are optional and may appear on any panel of the carton label in any combination}

{The contents of this page were added on 09/30/03}

This carton contains

DuoClear Cartridge	Corresponding System
<input type="checkbox"/> DuoClear 25 10,000 - 25,000 Gallons	DuoClear 25
<input type="checkbox"/> DuoClear 35 25,000 - 35,000 Gallons	DuoClear 35
<input type="checkbox"/> DuoClear 45 35,000 - 45,000 Gallons	DuoClear 45

Designed to fit DuoClear Systems for residential pools

Zodiac DuoClear Cartridge

For [10,000-25,000] [25,000-35,000] [35,000-45,000] Gallon Inground Pools

Fits DuoClear [25] [35] [45] System

Features Nature<sup>2</sup> Technology

Use only on Zodiac DuoClear systems for inground pools

Cartridge Model: DuoClear [25] [35] [45]

For [10,000 to 25,000] [25,000 to 35,000] [35,000 to 45,000] gallon pools

P/N [W20049] [20050] 20051]

Serial No. {insert number}

{for DuoClear replacement cartridges sticker placed on cartridge}

Replacement Cartridge for Zodiac DuoClear

For Inground Pools

Use only on Zodiac DuoClear Systems

If assistance is required, please call: 1-888-537-6657

**CAUTION:** Use only as directed – This cartridge must not be used in any other model or make of sanitizer. See installation and start-up instructions. Keep out of reach of children.

**EPA Est. No. 67712-FL-001**

**EPA Reg. No. 67712-1**

This product is covered by one or more of the following U.S. Patents: 4,608,247 4,935,116 5,352,369 372,069

W 17020

Features  
Nature<sup>2</sup>  
Technology



15/26

{language/pictures/diagrams on this page are optional and may appear on any panel of the carton label in any combination}

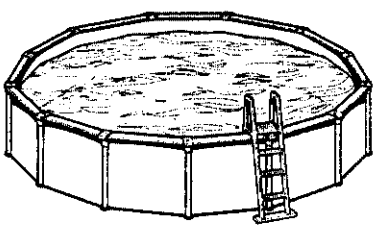

Nature<sup>2</sup>  
Mineral  
Cartridge  
The Low Chlorine Alternative\*

The  
Mineral  
Pool Sanitizer  
The Low Chlorine Alternative\*

{the graphic below was added on 09/30/03}





# ZODIAC



1/6/26

**EXPRESS™ CARTRIDGE**  
FOR INGROUND POOLS AND ABOVEGROUND POOLS

## Nature<sup>2</sup> G45-VC40 Owner's Manual

(above is text/logo for Express)

[For Nature<sup>2</sup> G Cartridges, Nature<sup>2</sup> M Cartridges, and Nature<sup>2</sup> VC Cartridge] EPA Reg. No. 67712-1 EPA Est. No. 67712-FL-001  
[Nature<sup>2</sup> CF Owner's Manual For Inground and Aboveground Pools with Cartridge Filters]

{Supplementals will insert their company name and logo}

### IMPORTANT

**Pool Owner, save this manual! Builders, leave this manual with the pool owner!**

### We ask you to take the time to get familiar with this manual.

Thank you for purchasing [insert product name] [with] Nature<sup>2</sup> [technology]. We believe the more you know, the more enjoyable your family's swimming experience will be—and the more you will reduce the time, effort and cost of maintaining your pool. Pool owners who switch from conventional chemical programs to the Nature<sup>2</sup> System\* spend less time maintaining their pools. Every pool has its own characteristics of water type, amount of sunlight, etc. The recipe [included in this manual] will help insure good water quality for your pool. Remember, your authorized [Zodiac Nature<sup>2</sup>] dealer can provide professional advice and service.

### SAFETY INSTRUCTIONS – Important information. Please read prior to installation

{see attached page for optional information that may be placed here}

 <b>ATTENTION</b>	Failure to heed the following may result in permanent injury, electrocution, or drowning.
--	---

#### ELECTRICAL HAZARD

- [Severe shock will likely occur as a result of a drill or drill cord coming in contact with water. Never allow electric drill or drill cord to come in contact with water. Only plug drill into a Class A (5 Milliampere Trip) protected Ground Fault Circuit Interrupter (GFCI) in accordance with the National Electrical Code Section 680. Please see your drill owner's manual for further safety precautions.]

#### EQUIPMENT UNDER PRESSURE

- Always turn pump off prior to installing or changing Nature<sup>2</sup> cartridge. Your pump/filter system is operated under pressure and the pressure must be released before you begin work. Please see your pump/filter owner's manual for further instructions.

#### PREVENT CHILD DROWNING

- Do not let anyone, especially small children, sit, step, lean or climb on any equipment installed as part of your pool's operational system. Locate the components of your operational system at least 3 feet from the pool so children cannot use the equipment to access the pool and be injured or drown.

#### LOW CHLORINE RECIPE

- You must strictly follow the low chlorine recipe included in this manual to maintain proper water chemistry and avoid health hazards. Failure to follow these instructions can lead to sickness from bacteria and other noxious organisms.

 <b>CAUTION</b>	<p><b>Precautionary Statement</b> <b>Hazards to Humans and Domestic Animals</b></p> <p><b>CAUTION</b> In the unlikely event that a cartridge breaks, mineral media should not be ingested by humans or animals as it may cause gastric distress</p> <p><b>First Aid</b> <b>IF INGESTED:</b> Call poison control center or doctor immediately for treatment advice.</p>
---	--

The Nature<sup>2</sup> [Pool] Sanitizer is designed only for residential swimming pools.

\* The Nature<sup>2</sup> System consists of the patented Nature<sup>2</sup>\* technology used in conjunction with a chlorine delivery device or 0.5ppm of an EPA registered chlorine pool product.

† Nature2™ technology consists of the minerals silver and copper.





17/26

[Optional Table of Contents]

Contents	Page	{the correct page numbers will be inserted for each manual}
Safety Instructions	1	
Start Up	2	
[Assembly]	3	
Balance the Water	3	
Install the Cartridge	3	
Recipe	4	
Provide Filtration/Circulation	4	
Troubleshooting	5	
Nature2 Cartridge Replacement Intervals	6	
Winterizing Your Pool	6	
Disposal	6	
Limited Warranty	7	

**Directions for Use:**

It is a violation of Federal law to use this product in a manner inconsistent with its labeling.

**Nature<sup>2</sup> Compatibility**

Nature<sup>2</sup> Systems\* can be used with all types of pool chemical treatments available except bromine and bromide based chemicals, biguanide products (Baqacil<sup>1</sup>, Softswim<sup>2</sup> or Revacil<sup>3</sup>) and copper based algacides. (<sup>1</sup>A Trademark of Avecia, Inc., <sup>2</sup>A Trademark of Biolab, Inc., <sup>3</sup>A Trademark of Mareva, Inc.)

**Important:** When converting either a biguanide or bromine treated pool to the Nature<sup>2</sup> System\*, the pool must be completely drained and refilled. Then follow the Nature<sup>2</sup> cartridge start-up procedure below.

**Important:** Please make sure that the Nature<sup>2</sup> cartridge you have selected corresponds to your swimming pool size based on gallons of water. Using a Nature<sup>2</sup> cartridge for an undersized pool may cause staining of the pool.]

**Start Up**

Before starting up a new [Nature<sup>2</sup>] cartridge, clean debris and algae out of the pool and [pool] equipment.

**Important:** *Do not install* the new cartridge until the pool water is clean and chemically balanced.

**Balance pool water** before installing [Nature<sup>2</sup>] [sanitizer] cartridge.

- pH 7.4-7.8
- Calcium Hardness 200-400 ppm
- Total Alkalinity 80-150 ppm

Consult with your [Nature<sup>2</sup>] [Zodiac] dealer for specific water balance instructions.

18/26

## Balance the Water

To find out if your pool water is balanced:

- take a water sample to your dealer to be tested regularly, or
- ask your dealer to recommend a pool test kit for water balance.

<b>Element:</b> pH <b>Range:</b> 7.4-7.8	<b>If it's too low:</b>	The surface of your pool can become etched. Metal parts in the pump and plumbing will corrode.	<b>How to fix:</b>	Add pH increaser.
	<b>If it's too high:</b>	"Scale" forms on the surface of your pool. The water can become cloudy. Equipment can become damaged.	<b>How to fix:</b>	Add pH decreaser.
<b>Element:</b> Calcium Hardness <b>Range:</b> 200-400 ppm	<b>If it's too low:</b>	Water is less stable. In plaster pools, the calcium is taken out of the plaster, causing the surface to deteriorate.	<b>How to fix:</b>	Add calcium hardness increaser.
	<b>If it's too high:</b>	Rough, discolored deposits ("scale") will form on the pool surface and inside pool equipment.	<b>How to fix:</b>	Drain or dilute the pool water. <b>Consult your dealer.</b>
<b>Element:</b> Total Alkalinity <b>Range:</b> 80-150 ppm	<b>If it's too low:</b>	It provides no buffer so that you constantly get fluctuating pH readings, which can damage equipment and pool surfaces.	<b>How to fix:</b>	Use an alkalinity increaser.
	<b>If it's too high:</b>	White deposits ("scale") form on the tile line. The plaster on pool surface becomes rough or discolored. The water becomes cloudy or milky white.	<b>How to fix:</b>	Add acid to bring alkalinity down.

## Install the Cartridge

**1 Install the cartridge [into your pool filter] after water is balanced.** [See] [Refer to] [the] [your] Nature<sup>2</sup> {the model name may also be inserted here} [vessel] operating manual for additional instructions [regarding your particular model's installation]. {the product name may be used in place of or in addition to the term "cartridge"}

**2 [Superoxidize] [Superchlorinate] the pool water with chlorine according to manufacturer's instructions to burn off contaminants and activate cartridge.**

**Important:** Initial superoxidation with chlorine is required to burn off contaminants and activate cartridge.

**3 Run the circulating pump either:**

- 24 hours a day for 4 days, maintaining 1-2 ppm [free] chlorine throughout, or
- 6 hours a day for 14 days, maintaining 1-2 ppm [free] chlorine throughout.

**4 Let chlorine dissipate to 0.5 ppm once start up period is completed.**

- Do not enter the pool if the free available chlorine residual is over 3 ppm.

19/26

# Recipe

There is one recipe for maintaining clean, clear, sanitized water with minimum time and effort. This recipe provides the easiest and most economical way to care for your Nature<sup>2</sup> pool.

**Low-Chlorine Recipe** Once the 4-day or 14-day start-up period is done, allow the free [available] chlorine residual to drop to 0.5 ppm (by reducing the amount of chlorine you add) then:

**Ingredients:**

- |  |  |  |
|--|--|--|
| <ul style="list-style-type: none"> <li>• Nature<sup>2</sup> cartridge<br/>{product name may be inserted}</li> <li>• Chlorine granules, tablets, liquid or generator</li> <li>• pH and total alkalinity adjusting chemicals</li> <li>• Calcium hardness increaser, if needed</li> <li>• Water test kit</li> </ul> | <p><b>When:</b></p> <p>Every day</p> <p>Once a week</p> <p>Twice a week</p> <p>As needed</p> | <p><b>What to do:</b></p> <p>Run pump and filter at least 6 hours every day.</p> <p>Balance pH and total alkalinity.</p> <p>Check chlorine residual; add chlorine to maintain at least [a] 0.5ppm [free chlorine] [range using the chart below].</p> <p>If water is hazy, superoxidize with chlorine according to manufacturer's instructions. Additional shocking is recommended following rainstorms or heavy bather load. Do not re-enter the pool if the free available chlorine residual is over 3 ppm.</p> |
|--|--|--|

Add the following amounts of chlorine per 10,000 gallons of water to increase free chlorine by 0.5 ppm

Type of Chlorine Containing Compound	% Active Ingredient	% Available Chlorine Content	Ounce Quantity Required	Gram Quantity Required
Sodium Hypochlorite Liquid	5.25	5.25	12.7	361
Sodium Hypochlorite Liquid	9.2	9.2	7.3	206
Sodium Hypochlorite Liquid	10	10	6.5	184
Sodium Hypochlorite Liquid	12	12	5.6	158
Calcium Hypochlorite	65	64	1.1	30
Dichloroisocyanurate	99	62	1.1	30
Lithium Hypochlorite	29	35	1.9	54
Trichloro-s-triazintrione	99	90	0.7	21
Chlorine Gas, from any source including chlorine generators	100	100	0.7	19

# Provide Filtration/Circulation

**To manage:**      **You need to:**

- Circulation** Follow the manufacturer's directions for keeping the circulating pump in good working order and operate it at least six hours a day. Consult your [Nature<sup>2</sup>] [Zodiac] dealer for optimum run times.
- Filtration** Check the pool's filter periodically and clean it as recommended by the manufacturer.

Note: Bracketed [ ] information is optional text/picture/diagram. Text separated by a comma (,) denotes and/or options. {Bracketed Text} is for administrative purposes only and will not appear on the printed label.

20/26

# Troubleshooting Guide

Consult your Nature 200 Dealer for additional assistance or call 1-888-537-6657.

	Problem	What to look for	Treatment
<b>Cloudy water</b>  Frequently caused by improper start up. See section on Start Up [and Install the Cartridge.]	Poor filtration	Slow filter turnover rates	1 Backwash and clean filter. 2 Run filter for 24 hours. 3 Increase run time per day.
	Algae growth	Hazy pool water, may have slightly green appearance.	[Superchlorinate] [Superoxidize] water with chlorine according to manufacturer's instructions and brush pool walls.
	Unbalanced water	1 High hardness 2 High TDS (total dissolved solids) 3 High pH 4 High total alkalinity	Balance the pool water.
<b>Algae</b>  Algae may be caused by insufficient levels of oxidizer and/or inadequate water circulation.	Green algae	Pea green color; attaches to pool walls; sometimes colors the entire body of water.	1 Check pH and adjust if necessary. 2 [Superchlorinate] [Superoxidize] with chlorine according to manufacturer's instructions and brush pool walls. 3 Repeat steps 1 and 2 until algae is gone.
	Black algae	Black spots on pool walls.	1 Brush affected areas. 2 [Superchlorinate] [Superoxidize] water with chlorine according to manufacturer's instructions.
	Mustard algae	Yellow or brown film on steps or walls.	3 Add algaecide. 4 Vacuum pool. 5 Repeat steps 1 through 4 until algae is gone.
<b>Note:</b> Regular algaecide treatments are recommended for outdoor pools that experience persistent algae problems. Do not use algae treatments containing either copper or sodium bromide.			
<b>Stains</b>	Blue/green	Copper or iron from pool equipment corrosion or water supply.	1 Adjust pH and total alkalinity to ideal ranges. 2 Vigorously brush stained areas. 3 Add sequestrant.
	Red/brown	Iron or manganese from equipment corrosion or water supply.	4 Run filter. 5 Twelve hours later, [superchlorinate] [superoxidize] pool.
	Black	Manganese in water supply.	6 Test and balance water. 7 Test pool water for dissolved metals.
	Metal tarnishing	High native mineral content in water; unbalanced water.	Clean with soft cloth and mild detergent. Test water for minerals; use a sequestrant; maintain water balance.
<b>Scale</b>	Crusty deposits on pool surfaces.	High pH and high total alkalinity	Adjust pH and total alkalinity to ideal ranges.
		High TDS (total dissolved solids) or high hardness levels.	1 Replace a volume of pool water with water low in hardness and dissolved solids.  2 Use sequestrant to prevent scale buildup if high hardness levels are a continuing problem.

[If you need further assistance, please call 1-800-910-4378.]

21/26

## Nature<sup>2</sup> Cartridge Replacement Intervals

[Use the month indicator ring on the top of the [cartridge] [unit]] [Monitor the cartridge replacement light on the DuoClear control panel] to identify the date on which the cartridge should be replaced.] Always turn pump off prior to installing or changing [a] Nature<sup>2</sup> [the model name may be inserted here] cartridge. Your pump/filter is operated under pressure and the pressure must be released before you begin work. Please see your pump/filter owner's manual for further instruction.

A cartridge lasts [six][(6)] [four][(4)] months or one season, whichever is shorter. The cartridge should not be used longer than [six][(6)] [four][(4)] continuous months.

{The frost-belt and sun-belt information is optional language that may be used in some but not all owner's manuals}

### [In frost-belt regions (3-6 month pool season):

Discard your used system when you close your pool at the end of the season. Install a new system when you open your pool in the spring.]

### [In sun-belt regions (7-12 month pool season):

Replace your Nature<sup>2</sup> cartridge every 6 months whether or not you plan to use the pool for swimming. ]

## Winterizing Your Pool

Use these steps as a guide. Consult your dealer for specific information [in] [on] your area.

### Warm Climate

- 1 Reduce the number of hours the pump runs since the cooler weather decreases the spread of algae and other pollutants.
- 2 There is no need to [superoxidize] [superoxidize] the pool during cool weather unless the water becomes cloudy (as may occur after a winter storm). See Cloudy Water in Troubleshooting section.

### Cold Climate

- 1 Check total alkalinity and pH of pool to make sure that they are in proper balance.
- 2 Vacuum the pool bottom to remove any debris or other potential contaminants.
- 3 [Superoxidize] [Superchlorinate] the pool with chlorine according to manufacturer's instructions to clear the water.
- 4 Add a winter algaecide following manufacturer's instructions.

**Important:** Do *not* use a winter algaecide with copper in it. [This will void the Nature<sup>2</sup> no-stain warranty.]

- 5 Backwash the filter.
- 6 Drain part of the pool water. The amount to drain varies from one part of the country to another. Consult your dealer for advice.
- 7 Remove the [Nature<sup>2</sup>] [sanitizer system] cartridge and discard with household trash.
- 8 Winterize the pipes with pool antifreeze following manufacturer's instructions.
- 9 Drain the water out of all equipment (pump, filter, etc.)
- 10 Store all baskets, hoses and cleaning equipment, indoors if possible.
- 11 Cover the pool with a winter cover.

## Disposal

After [six] [four] months of use, discard [Nature<sup>2</sup>] cartridge in household trash. Do not save the cartridge for re-use. The cartridge is manufactured with the mineral media sealed inside. In the unlikely event a cartridge breaks, remove it and vacuum out any media introduced into the pool.

22/26

{language/pictures/diagrams on this page are optional and may appear on any panel of the carton label in any combination}

{The following warranty statement(s) will not be on supplemental labels}

## Limited Warranty

### Nature<sup>2®</sup> Limited Warranty

The limited warranties contained within this document are the only warranties given with your Nature<sup>2®</sup> [insert model name] [Sanitizer] Cartridge and supercede any prior warranties. **All other warranties, expressed or implied, including the implied warranty of merchantability or the implied warranty of fitness for a particular purpose are hereby disclaimed.** Our sole obligation under this warranty, and the purchaser's sole remedy, is limited to repair or replacement of the [Nature<sup>2</sup>] [Nature<sup>2</sup> G Cartridge[s]] [Nature<sup>2</sup> M Cartridge[s]] [and] [Nature<sup>2</sup> VC Cartridge[s]] [and] [Nature<sup>2</sup> VC Cartridge[s]] [Nature<sup>2</sup> Express] [Nature<sup>2</sup> CF] [Sanitizer] [cartridge], [or one of its parts]. The Nature<sup>2®</sup> warranty applies to the original owner only.

**[THE LIMITED WARRANTIES OF THE [NATURE<sup>2®</sup>] [Nature<sup>2</sup> G Cartridge[s]] [Nature<sup>2</sup> M Cartridge[s]] [and] [Nature<sup>2</sup> VC Cartridge[s]] [Nature<sup>2</sup> CF] [Nature<sup>2</sup> Express] [Cartridge[s]] [Inground] [SANITIZER[s]] [ARE]]:**  
[The] [Nature<sup>2</sup>] [Nature<sup>2</sup> G Cartridges] [Nature<sup>2</sup> M Cartridges] [and] [Nature<sup>2</sup> VC Cartridges] [Nature<sup>2</sup> CF] [Nature<sup>2</sup> Express] [Sanitizer] [cartridges] [are] [is] warranted to be free of defects in materials and to perform satisfactorily for a period of [six] [four] months from the date of purchase. Nature<sup>2®</sup> [insert model name] [Sanitizer] [cartridges] [are] [is] warranted not to cause copper staining in your pool. This limited warranty requires that you exercise reasonable care of your pool and keep water in balance at all times and not use a copper-based algaecide. This [limited] warranty does not cover discoloration to chromium fittings. This warranty does not cover cartridges used with any biguanide products such as Baquacil<sup>®</sup> or Soft Swim<sup>®</sup> or any products containing Bromine or Bromine-based chemicals. If the cartridge is defective and does not perform satisfactorily for the entire [six] [four] months, we will [make a prorata rebate based on your actual period of use. **You are responsible to pay the below-indicated percentage on the then applicable retail cost: <1 month-0%; 1-2 months-25%; 3-4 months-50%; 5-<6 months-75%.**] [replace your cartridge.]

### EXCLUSIONS FROM WARRANTY

[The] [Nature<sup>2®</sup>] [Nature<sup>2</sup> G Cartridge[s]] [Cartridge[s] M] [and] [Nature<sup>2</sup> VC Cartridges] [Nature<sup>2</sup> CF] [Nature<sup>2</sup> Express Cartridge[s]] [Sanitizer] [Cartridges] [is] [are] designed for use on [inground] [and] [aboveground] pools [with cartridge filters] from [5,000 to 25,000] [5,000 to 45,000] [10,000 to 45,000] gallons [depending on cartridge model]. If it is used in any other application, the warranty is void, and the purchaser and/or pool owner releases the manufacturer from [any and] all claims related to the use of the Nature<sup>2®</sup> [Sanitizer] [Express] [Cartridge].

This warranty does not cover problems arising in whole or in part from purchaser's negligence, misuse or abuse, improper maintenance or storage, accident, improper installation, improper application, failure to follow all appropriate safety precautions, Acts of God, abnormal weather conditions, damage from plants or animals, and improper use of chemicals.

This warranty specifically excludes all incidental or consequential damages, except where state law requires them to be paid. This warranty gives you specific rights. You may have other rights that vary from state to state.

### TO SUBMIT A CLAIM

Report claims to Zodiac Pool Care, Inc. by calling 1-888-537-6657. Only the original purchaser may submit a claim under this limited warranty. [All] Claims must be accompanied by an original purchase receipt.



Zodiac Pool Care, Inc.  
10000 North Central Expressway  
Dallas, Texas 75243  
Tel: 888-537-6657  
Fax: 972-382-2200  
www.zodiacpoolcare.com

Nature2 is a registered trademark [owned by] [of] Zodiac Pool Care, Inc.

Printed in the USA

© Copyright 2002 Zodiac Pool Care, Inc.

{optional manual part numbers} {W17545} {W17510} {W17570}

23/26

{language/pictures/diagrams on this page are optional and may appear on any panel of the carton label in any combination}

{optional chart(s) for Nature<sup>2</sup> cartridges}

CARTRIDGE CAPACITY

G Cartridge	10,000 - 25,000 gallons
	25,000 - 35,000 gallons
	35,000 - 45,000 gallons
M Cartridge	5,000 - 25,000 gallons
VC Cartridge	5,000 - 20,000 gallons
	20,000 - 40,000 gallons

CARTRIDGE CAPACITY

DuoClear Cartridge	10,000 - 25,000 gallons
	25,000 - 35,000 gallons
	35,000 - 45,000 gallons

{additional optional language for first page}

Features Nature<sup>2</sup> Technology<sup>†</sup>

insert product name; with Nature<sup>2</sup> Technology

{optional language for Safety Instructions}

[Nature<sup>2</sup>] [Nature<sup>2</sup> G Cartridge[s]] [Nature<sup>2</sup> M Cartridge[s]] [and] [Nature<sup>2</sup> VC Cartridge[s]] [CF] [Express] [Cartridge[s]] [have] [has] been designed to sanitize swimming pools from [5,000 to 25,000] [5,000 - 45,000] [10,000 to 45,000] gallons [depending on cartridge model. Make sure that your Nature<sup>2</sup> [Sanitizer] Cartridge corresponds with the proper vessel and is appropriate for your pool size by consulting the chart above.]

{additional optional chart for Hayward supplementals}

This owner's manual covers the following SwimPure cartridges:

- N2CN25 - For inground or aboveground pools 5,000 - 25,000 gallons
- J2CN35 - For inground pools 25,000 - 35,000 [gallons]
- N2CW25 - For inground or aboveground pools 5,000 - 25,000 gallons
- N2CW35 - For inground pools 25,000 - 35,000 [gallons]

- N2S25 - For inground or aboveground pools 5,000 - 25,000 gallons
- N2S35 - For inground or aboveground pools 25,000 - 35,000 [gallons]

{additional optional descriptive language for Hayward supplementals}

For inground and aboveground pools with [cartridge] [sand] filters

24/26

{language/pictures/diagrams on this page are optional and may appear on any panel of the carton label in any combination}

# Assembly

The Nature<sup>2</sup> CF consists of 4 sanitizer elements, 2 end caps and 2 end spikes.

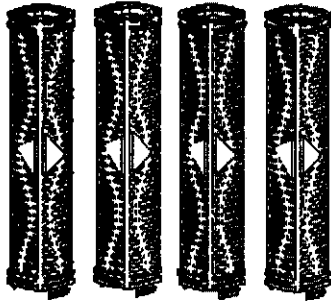

Sanitizer Elements

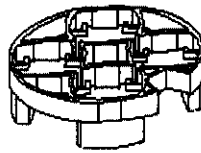
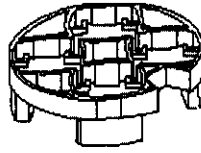

Endcaps

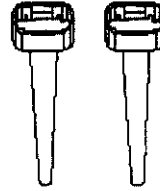

Spikes

Depending upon the size of your swimming pool cartridge filter, these parts can be assembled as a bundle of 4 sanitizer elements, or as 2 sticks of 2 elements each.

**NOTE:** You should first attempt to use the bundle assembly.

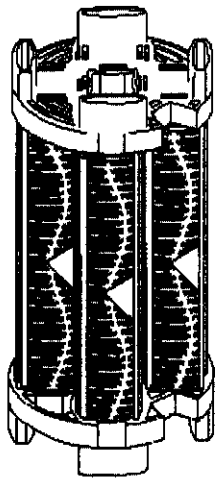

Bundle Assembly

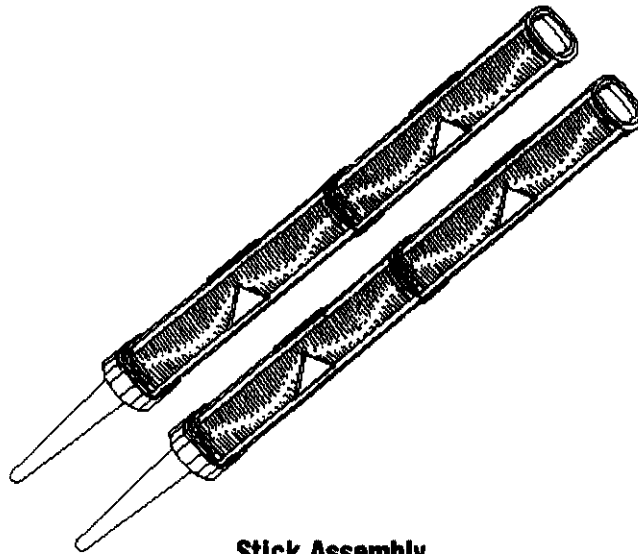

Stick Assembly

## Decide which Nature<sup>2</sup> CF assembly is right for your pool filter.

- 1 Turn off the pump and disassemble the pool filter as you normally would to clean the cartridge.
- 2 Check to see if the endcap fits easily into the core of your cartridge filter:
  - if it does, go to Bundle Assembly
  - if it does not, go to Stick Assembly



{language/pictures/diagrams on this page are optional and may appear on any panel of the carton label in any combination}

## Bundle Assembly

The hole in the center of the endcap accommodates a center rod should your filter have one.

- 1 Lay an end cap on a flat surface and snap the 4 sanitizer elements into it,** so that the tabs are pointing up.

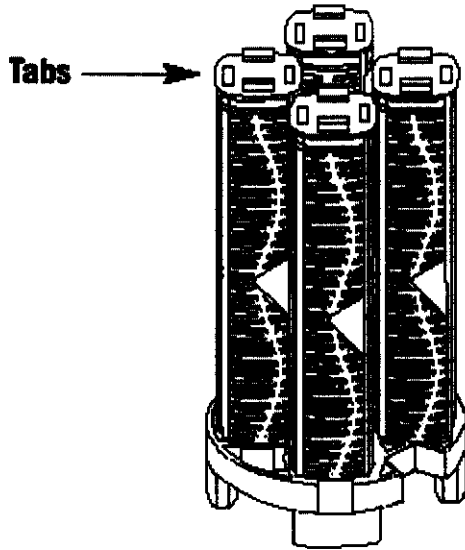

- 2 Snap the other end cap on top.**

---

**Important:** Be sure that the notch on each end cap lines up together to accommodate an air bleed tube.

---

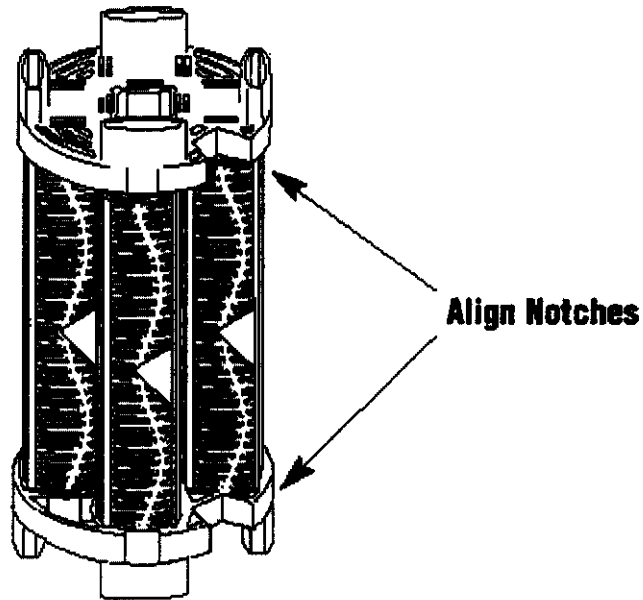

26/26

{language/pictures/diagrams on this page are optional and may appear on any panel of the carton label in any combination}

# Stick Assembly

**Important:** Use only after attempting the Bundle Assembly.

**1 Snap two sanitizer elements together** so that each tab and slot line up.



**2 Snap the end spike to one end.**

**NOTE:** Once assembled, do not attempt to separate the sanitizer elements as the tabs may break.

