



UNITED STATES ENVIRONMENTAL PROTECTION AGENCY
WASHINGTON, DC 20460

OFFICE OF CHEMICAL SAFETY
AND POLLUTION PREVENTION

October 14, 2015

Robin R. Charlton, Ph.D.
Senior Regulatory Scientist
Registration and Regulatory Affairs
Valent U.S.A. Corporation
1600 Riviera Ave. Ste. 200
Walnut Creek, CA 94596-8025

Subject: Label Amendment – Addition of products to tables listing compatible tank mix partners, changes to language regarding adjuvants
Product Name: Cobra Herbicide
EPA Registration Number: 59639-34
Application Date: 09/25/2015
Decision Number: 509838

Dear Dr. Charlton:

The amended label referred to above, submitted in connection with registration under the Federal Insecticide, Fungicide and Rodenticide Act, as amended, is acceptable. This approval does not affect any conditions that were previously imposed on this registration. You continue to be subject to existing conditions on your registration and any deadlines connected with them.

A stamped copy of your labeling is enclosed for your records. This labeling supersedes all previously accepted labeling. You must submit one copy of the final printed labeling before you release the product for shipment with the new labeling. In accordance with 40 CFR 152.130(c), you may distribute or sell this product under the previously approved labeling for 18 months from the date of this letter. After 18 months, you may only distribute or sell this product if it bears this new revised labeling or subsequently approved labeling. "To distribute or sell" is defined under FIFRA section 2(gg) and its implementing regulation at 40 CFR 152.3.

Should you wish to add/retain a reference to the company's website on your label, then please be aware that the website becomes labeling under the Federal Insecticide Fungicide and Rodenticide Act and is subject to review by the Agency. If the website is false or misleading, the product would be misbranded and unlawful to sell or distribute under FIFRA section 12(a)(1)(E). 40 CFR 156.10(a)(5) list examples of statements EPA may consider false or misleading. In addition, regardless of whether a website is referenced on your product's label, claims made on the website may not substantially differ from those claims approved through the registration process. Therefore, should the Agency find or if it is brought to our attention that a website contains false or misleading statements or claims substantially differing from the EPA approved registration, the website will be referred to the EPA's Office of Enforcement and Compliance.

Page 2 of 2
EPA Reg. No. 59639-34
Decision No. 509838

Your release for shipment of the product constitutes acceptance of these conditions. If these conditions are not complied with, the registration will be subject to cancellation in accordance with FIFRA section 6. If you have any questions, please contact Lisa Pabel by phone at 703-347-0459, or via email at pabel.lisa@epa.gov.

Sincerely,

A handwritten signature in cursive script that reads "Heather A. Garvie".

Heather A. Garvie, Product Manager 24
Fungicide Herbicide Branch (7505P)
Office of Pesticide Programs

Enclosure



GROUP 14 HERBICIDE

[Bracketed text is optional]

[Roundup Ready PLUS® Crop Management Solutions]

ACCEPTED
10-14-2015
Under the Federal Insecticide, Fungicide and Rodenticide Act as amended, for the pesticide registered under EPA Reg. No. 59639-34

COBRA® HERBICIDE

Table with 2 columns: Active Ingredient, By Wt.
*Lactofen 24%
Other Ingredients 76%
Total 100%

*2-ethoxy-1-methyl-2-oxoethyl 5-[2-chloro-4-(trifluoromethyl)phenoxy]-2-nitrobenzoate

Contains petroleum distillates.

Contains 2 lbs of active ingredient per gallon

KEEP OUT OF REACH OF CHILDREN

DANGER – PELIGRO

SEE NEXT PAGE FOR ADDITIONAL PRECAUTIONARY STATEMENTS.

Si usted no entiende la etiqueta, busque a alguien para que se la explique a usted en detalle. (If you do not understand the label, find someone to explain it to you in detail).

EPA Reg. No. 59639-34

NET CONTENT 1 GALLON
2-1/2 GALLON
250 GALLONS (946.35 L)

PRECAUTIONARY STATEMENTS

HAZARDS TO HUMANS & DOMESTIC ANIMALS

DANGER: Corrosive. Causes skin burns and irreversible eye damage. Harmful if swallowed, inhaled or absorbed through skin. Do not get in eyes or on skin or clothing. Avoid breathing vapor or spray mist. This product contains lactofen, which has been determined to cause tumors in laboratory animals (mouse, rat). Risks can be reduced by closely following use directions and precautions, and by wearing the protective clothing specified elsewhere on this label.

FIRST AID	
If in eyes:	<ul style="list-style-type: none">• Hold eye open and rinse slowly and gently with water for 15-20 minutes.• Remove contact lenses, if present, after the first 5 minutes, then continue rinsing eye.• Call a poison control center or doctor for treatment advice.
If swallowed:	<ul style="list-style-type: none">• Immediately call a poison control center or doctor.• Do not induce vomiting unless told to by a poison control center or doctor.• Do not give any liquid to the person.• Do not give anything by mouth to an unconscious person.
If on skin or clothing:	<ul style="list-style-type: none">• Take off contaminated clothing.• Rinse skin immediately with plenty of water for 15-20 minutes.• Call a poison control center or doctor for treatment advice.
If inhaled:	<ul style="list-style-type: none">• Move person to fresh air.• If person is not breathing, call 911 or an ambulance, then give artificial respiration, preferably by mouth-to-mouth, if possible.• Call a poison control center or doctor for further treatment advice.
HOT LINE NUMBER Have the product container or label with you when calling a poison control center or doctor or going for treatment. You may also contact 1-800-892-0099 for emergency medical treatment information.	
NOTE TO PHYSICIAN Ingestion of this product or subsequent vomiting can result in aspiration of light hydrocarbon liquid, which can cause pneumonitis.	

PERSONAL PROTECTIVE EQUIPMENT (PPE):

Applicators and other handlers must wear: coveralls over long-sleeved shirt and long pants, chemical-resistant gloves, such as Barrier Laminate or Viton \geq 14 mils, chemical-resistant footwear plus socks, protective eyewear, chemical-resistant headgear for overhead exposure and chemical-resistant apron when cleaning equipment, mixing or loading.

Discard clothing and other absorbent materials that have been drenched or heavily contaminated with this product's concentrate. Do not reuse them. Follow manufacturer's instructions for cleaning/maintaining PPE. If no such instructions for washables, use detergent and hot water. Keep and wash PPE separately from other laundry.

USER SAFETY RECOMMENDATIONS

Users should:

- Wash hands before eating, drinking, chewing gum, using tobacco or using the toilet.
- Remove clothing immediately if pesticide gets inside. Then wash thoroughly and put on clean clothing.
- Remove clothing/PPE immediately after handling this product. Wash the outside of gloves before removing. As soon as possible, wash thoroughly and change into clean clothing.

ENVIRONMENTAL HAZARDS:

This pesticide is toxic to fish. Do not apply directly to water, or to areas where surface water is present or to intertidal areas below the mean high water mark. Drift and runoff from treated areas may be hazardous to aquatic organisms in neighboring areas. Do not contaminate water by cleaning of equipment or disposal of waste. Do not apply when weather conditions favor drift from target area.

PHYSICAL OR CHEMICAL HAZARDS:

Combustible. Do not use or store near heat or open flame.

DIRECTIONS FOR USE

It is a violation of Federal law to use this product in a manner inconsistent with its labeling.

READ ENTIRE LABEL. USE STRICTLY IN ACCORDANCE WITH PRECAUTIONARY STATEMENTS AND DIRECTIONS AND WITH APPLICABLE STATE AND FEDERAL REGULATIONS.

Do not apply this product in a way that will contact workers or other persons, either directly or through drift. Only protected handlers may be in the area during application. For any requirements specific to your State or Tribe, consult the agency responsible for pesticide regulation.

AGRICULTURAL USE REQUIREMENTS

Use this product only in accordance with its labeling and with the Worker Protection Standard (WPS), 40 CFR part 170. This Standard contains requirements for the protection of agricultural workers on farms, forests, nurseries, and greenhouses, and handlers of agricultural pesticides. It contains requirements for training, decontamination, notification and emergency assistance. It also contains specific statements on this label about Personal Protective Equipment (PPE), and Restricted-Entry Interval (REI). The requirements in this box only apply to uses of this product that are covered by the WPS.

Do not enter or allow worker entry into treated areas during the REI of 12 hours.

PPE required for early entry to treated areas that is permitted under the WPS and that involves contact with anything that has been treated, such as plants, soil or water, is: coveralls over long-sleeved shirt and long pants, chemical-resistant gloves, such as Barrier Laminate or Viton \geq 14 mils, chemical-resistant footwear plus socks, protective eyewear and chemical-resistant headgear for overhead exposure.

**DISCLAIMER, RISKS OF USING THIS PRODUCT,
LIMITED WARRANTY
AND LIMITATION OF LIABILITY**

IMPORTANT: Read the entire Label including this Disclaimer, Risks of Using this Product, Limited Warranty, and Limitation of Liability before using this product. If the terms are not acceptable THEN DO NOT USE THE PRODUCT; rather, return the unopened product within 15 days of purchase for a refund of the purchase price.

RISKS OF USING THIS PRODUCT

The Buyer and User (referred to collectively herein as "Buyer") of this product should be aware that there are inherent unintended risks associated with the use of this product which are impossible to eliminate. These risks include, but are not limited to, injury to plants and crops to which this product is applied, lack of control of the target pests or weeds, resistance of the target pest or weeds to this product, injury caused by drift, and injury to rotational crops caused by carryover in the soil. Such risks of crop injury, non-performance, resistance or other unintended consequences are unavoidable and may result because of such factors as weather, soil conditions, disease, moisture conditions, irrigation practices, condition of the crop at the time of application, presence of other materials either applied in the tank mix with this product or prior to application of this product, cultural practices or the manner of use or application, (or a combination of such factors) all of which are factors beyond the control of Valent. The Buyer should be aware that these inherent unintended risks may reduce the harvested yield of the crop in all or a portion of the treated acreage, or otherwise affect the crop such that additional care, treatment and expense are required to take the crop to harvest. If the Buyer chooses not to accept these risks, THEN THIS PRODUCT SHOULD NOT BE APPLIED. By applying this product Buyer acknowledges and accepts these inherent unintended risks AND TO THE FULLEST EXTENT ALLOWED BY LAW, AGREES THAT ALL SUCH RISKS ASSOCIATED WITH THE APPLICATION AND USE ARE ASSUMED BY THE BUYER.

Valent shall not be responsible for losses or damages (including, but not limited to, loss of yield, increased expenses of farming the crop or such incidental, consequential or special damages that may be claimed) resulting from use of this product in any manner not set forth on the label. Buyer assumes all risks associated with the use of this product in any manner or under conditions not specifically directed or approved on the label.

LIMITED WARRANTY

Valent warrants only that this product conforms to the chemical description on the label and is reasonably fit for the purposes stated in the label, under average use conditions, when used strictly in accordance with the label and subject to the Risks of Using This Product as described above. To the extent consistent with applicable law AND AS SET FORTH ABOVE, VALENT MAKES NO OTHER WARRANTIES, EITHER EXPRESSED OR IMPLIED. No agent or representative of Valent or Seller is authorized to make or create any other express or implied warranty.

LIMITATION OF LIABILITY

To the fullest extent allowed by law, Valent or Seller is not liable for any incidental, consequential, indirect or special damages resulting from the use or handling of this product. The limitation includes, but is not limited to, loss of yield on all or any portion of the treated acreage, increased care, treatment or other expenses required to take the crop to harvest, increased finance charges or altered finance ratings, emotional or mental distress and/or exemplary damages. TO THE FULLEST EXTENT ALLOWED BY LAW, THE EXCLUSIVE REMEDY OF THE BUYER, AND THE EXCLUSIVE MAXIMUM LIABILITY OF VALENT OR SELLER FOR ANY AND ALL CLAIMS, LOSSES, INJURIES OR DAMAGES (INCLUDING CLAIMS BASED ON BREACH OF WARRANTY, CONTRACT, NEGLIGENCE, TORT, STRICT LIABILITY OR OTHERWISE) RESULTING FROM THE USE OR HANDLING OF THIS PRODUCT SHALL BE THE RETURN OF THE PURCHASE PRICE OF THIS PRODUCT OR, AT THE ELECTION OF VALENT OR SELLER, THE REPLACEMENT OF THE PRODUCT.

PROMPT NOTICE OF CLAIM

To the extent consistent with applicable law allowing such requirements, Valent must be provided notice as soon as Buyer has reason to believe it may have a claim, but in no event later than twenty-one days from date of planting, or twenty-one days from the date of application, whichever is latter, so that an immediate inspection of the affected property and growing crops can be made.

To the extent consistent with applicable law, if Buyer does not notify Valent of any claims, in such period, it shall be barred from obtaining any remedy.

NO AMENDMENTS

Valent and Seller offer this product, and Buyer accepts it, subject to the foregoing **Disclaimer, Risks of Using This Product, Limited Warranty** and **Limitation of Liability**, which may not be modified by any oral or written agreement.

TANK MIXES

NOTICE: Tank mixing of this product with any other product which is not specifically and expressly authorized by the label shall be the exclusive risk of user, applicator and/or application advisor, to the extent allowed by applicable law.

Read and follow the entire label of each product to be used in the tank mix with this product.

RESISTANCE MANAGEMENT RECOMMENDATION

Cobra[®] Herbicide is a Group 14 herbicide (PPO inhibitor). Any weed population may contain or develop plants naturally resistant to herbicides in various mode of action classes. Resistant biotypes, such as waterhemp, may eventually dominate the weed population if the same class of chemistry/mode of action herbicides are used repeatedly in the same field or in successive years. These resistant biotypes may not be adequately controlled by herbicides in a mode of action class for which resistance has developed. A gradual or total loss of weed control may occur over time. Other resistance mechanisms that are not linked to site of action, such as enhanced metabolism, may also exist. Appropriate resistance management strategies should be followed.

TO DELAY HERBICIDE RESISTANCE

- Avoid the use of herbicides that have a similar target site mode of action in consecutive years. Other Group 14 herbicides (PPO inhibitors) include acifluorfen (Ultra Blazer[®]) and fomesafen (Flexstar[®], Reflex[®]). If resistant weed biotypes such as waterhemp are suspected or known to be present, use a tank mix partner with *Cobra* Herbicide to help control these biotypes, or use a planned herbicide rotation program where residual broadleaf herbicides having different modes of action are used.
- Herbicide use should be based on an IPM program that includes scouting, record keeping, and consideration of cultivation practices, water management, weed-free crop seed, crop rotation and other chemical or cultural control practices.
- Monitor treated weed population for resistance development and report suspected resistance.
- Contact your local extension or crop expert (advisor) for any additional pesticide resistance management and/or IPM recommendations for specific crops and weed biotypes.
- For further information contact Valent U.S.A. Corporation at the following toll free number 800-682-5368.

GROUNDWATER ADVISORY

This chemical (lactofen) has properties and characteristics associated with chemicals detected in groundwater. Acifluorfen, a degradate of this chemical, is known to leach through soil into groundwater under certain conditions as a result of labeled use. Use of this chemical in areas where soils are permeable, particularly where the water table is shallow, may result in groundwater contamination.

TABLE OF CONTENTS

PRODUCT INFORMATION	
Restrictions	
Environmental Conditions and Biological Performance	
Rainfastness	
Adjuvants and Additives	
Table 1. Adjuvant Recommendations.....	
Jar Test to Determine Compatibility of Adjuvants and <i>Cobra</i> Herbicide.....	
Mixing Instructions	
Application Equipment	
Spray Drift Management	
Broadcast Application	
Aerial Application	
Application and Cultivation	
Sequential Applications.....	
Crop Failure	
Rotational Restrictions	
DIRECTIONS FOR USE IN SOYBEANS	
Crop Information	
Restrictions	
Application Timing.....	
Table 2. Weeds Controlled by Postemergence Activity of <i>Cobra</i> Herbicide	
Table 3. Weeds Suppressed by Postemergence Activity of <i>Cobra</i> Herbicide	
Tank Mix Partners for use in Soybeans – Preplant/Preemergence Application	
Table 4. Tank Mix Partners for <i>Cobra</i> Herbicide for Preplant/Preemergence	
Application in Soybean	
Table 5. Weeds Controlled by Preemergence Activity of <i>Cobra</i> Herbicide	
Tank Mix Partners for Use in Soybeans - Postemergence Application	
Table 6. Tank Mix Partners for <i>Cobra</i> Herbicide for Postemergence Application in Soybean	
Table 7. Disease Suppression by <i>Cobra</i> Herbicide	
Precaution.....	
DIRECTIONS FOR USE IN COTTON	
Crop Information	
Restrictions	
Limitations.....	
Tank Mix Partners for Use in Cotton.....	
Table 8. Tank Mix Partners for <i>Cobra</i> Herbicide Layby Application in Cotton	
Cotton Tolerance.....	
Timing	
Cultivation	
Application Rates	
Adjuvants	
Table 9. Adjuvant Recommendations for Use in Cotton	

DIRECTIONS FOR USE IN PEANUTS
 Crop Information
 Restrictions
 Early Postemergence Treatment.....
 Adjuvant and Additives.....
 Crop Tolerance
 Tank Mix Partners for Use in Peanuts.....
 Table 10. Tank Mix Partners for *Cobra* Herbicide Postemergence Application in Peanuts

DIRECTIONS FOR OUTDOOR USE IN CONIFER SEEDLINGS AND NURSERIES

Crop Information
 Conifer Species.....
 Preemergence Application
 Table 11. Preemergence Applications to Conifer Seedlings
 Postemergence Application.....
 Table 12. Postemergence Applications to Conifer Seedlings
 Application Instructions
 Use Restrictions for *Cobra* Herbicide in Conifer Seedlings.....

DIRECTIONS FOR POST-DIRECTED APPLICATION IN KENAF

Crop Information
 Kenaf Tolerance.....
 Timing
 Directed Band Application
 Cultivation
 Application Rates
 Table 13. *Cobra* Herbicide Rates Post-Directed: KENAF

STORAGE AND DISPOSAL

PRODUCT INFORMATION

Cobra Herbicide is a selective, broad spectrum herbicide for preemergence and postemergence control of susceptible broadleaf weeds. *Cobra* Herbicide is formulated as an emulsifiable concentrate containing 2 lbs of active ingredient per gallon. In the Midwest, postemergence application of *Cobra* Herbicide to soybeans (at or just before 1st bloom) has resulted in suppression of the soybean disease white mold caused by *Sclerotinia sclerotiorum*.

Cobra Herbicide works primarily through contact action. Good coverage of young, actively growing weeds is essential for maximum weed control. The use of a spray adjuvant is usually required. Refer to the label section on ADJUVANTS AND ADDITIVES for specific recommendations.

When *Cobra* Herbicide is applied postemergence, a portion of the spray solution may contact the soil surface. If soil moisture conditions are favorable for **preemergence activity** following the application, suppressed germination of small-seeded broadleaf weeds, such as nightshade and pigweed species (including waterhemp and Palmer amaranth) may be expected for a 2 week period with rates of 10 fl oz/A or greater. The presence of excessive crop or weed foliage at the time of application will reduce the amount of herbicide spray contacting the soil surface and will reduce the level of soil activity.

A **temporary crop response** should be expected following a postemergence application of *Cobra* Herbicide. Leaves which are open at the time of application will show some burn, bronzing and speckling. Leaves which have emerged but are unopened at the time of application may appear cupped at the tip and/or crinkled along the edges of the leaf. Labeled crops quickly outgrow all initial herbicide effects. When *Cobra* Herbicide is used as directed **yields will not be adversely affected**.

RESTRICTIONS

Do not apply this product through any type of irrigation system.
Do not make more than two applications per acre per season.

ENVIRONMENTAL CONDITIONS AND BIOLOGICAL PERFORMANCE

For best results, apply *Cobra* Herbicide to actively growing weeds within the growth stages indicated in this label. Applying *Cobra* Herbicide under conditions that do not promote active weed growth will reduce herbicide effectiveness. Do not apply *Cobra* Herbicide when the crop or weeds are under stress due to drought, excessive water, extremes in temperature, disease or low humidity. Weeds under stress tend to become less susceptible to herbicidal action. *Cobra* Herbicide is most effective when applied under sunny conditions at temperatures above 70°F.

RAINFASTNESS

Cobra Herbicide is rainfast 30 minutes after application. Do not apply *Cobra* Herbicide if rain is expected within 30 minutes of application or efficacy may be reduced.

ADJUVANTS AND ADDITIVES

The addition of an adjuvant to *Cobra* Herbicide is required for postemergence weed control. Use of a crop oil concentrate (COC), including methylated seed oils (MSO), containing at least 15% emulsifier or non-ionic surfactant containing at least 80% surfactant is recommended. The addition of nitrogen (28, 30 or 32%) or ammonium sulfate, in combination with COC or non-ionic surfactant, may enhance weed control. Mixing and compatibility qualities should be verified by a jar test.

Crop Oil Concentrate: Crop oil concentrate is the preferred adjuvant with *Cobra* Herbicide for weed control over a wide spectrum of application conditions. Higher levels of crop response are also generally observed with the use of a crop oil concentrate; however crops quickly outgrow all initial herbicide effects. The rate of crop oil concentrate will depend on the environmental conditions preceding the application and the weed size and species at the time of application. If environmental conditions are good and weeds are growing vigorously, use of the low rate of crop oil concentrate is recommended. The higher rate is required when the weeds are under environmental stress such as low temperature, low humidity or low soil moisture.

Non-Ionic Surfactant (NIS): Under optimal growing conditions, and when weeds are actively growing, a NIS may be used in place of a crop oil concentrate.

Drift Control Additives

Drift control additives are not recommended with *Cobra* Herbicide.

Also refer to crop specific directions for any additional adjuvant recommendations.

Table 1. Adjuvant Recommendations

ADJUVANT	PERCENT RELATIVE HUMIDITY		
	> 80% (High)	60 to 80% (Medium)	< 60% (Low)
Non-Ionic Surfactant (NIS) or	0.25% v/v	Not Recommended	Not Recommended
Crop Oil Concentrate (COC) / Methylated Seed Oil (MSO)	1 pt/A	1.5 pt/A	2 pt/A
A nitrogen source, such as ammonium sulfate (2.5 lb/A) or 28% (1 qt/A) may be added to enhance weed control.			

v/v is volume NIS/volume of the tank solution.

JAR TEST TO DETERMINE COMPATIBILITY OF ADJUVANTS AND COBRA HERBICIDE

A jar test should be performed before mixing commercial quantities of *Cobra* Herbicide when using *Cobra* Herbicide for the first time, when using new adjuvants, or when a new water source is being used.

1. Add 1 pt of the water to a quart jar. The water should be from the same source and temperature as will be used in the spray tank mixing operation.
2. Add 2 ml (0.4 tsp) of *Cobra* Herbicide to the quart jar, gently mix until product dissipates.
3. Add 6 ml (1 tsp) of the crop oil concentrate or methylated seed oil to the quart jar, gently mix. If a non-ionic surfactant is being used in a tank mix, add 2.5 ml (0.5 tsp) of the non-ionic surfactant in place of the oil.
4. If nitrogen is being used, add 16 ml (1 tbsp or 0.5 oz) of the 28 to 32% nitrogen source to the quart jar. If ammonium sulfate (AMS) is being used, add 19 gms (0.04 lbs) AMS to the quart jar in place of the 28 to 32% nitrogen. Add Ammonium sulfate to the jar before the *Cobra* Herbicide in step 2.
5. Place cap on jar, invert 10 times, let stand for 15 minutes, evaluate.
6. An ideal tank mix combination will be uniform and free of suspended particles. If any of the following conditions are observed the choice of adjuvant should be questioned:
 - a) Layer of oil or globules on the mixture's surface.
 - b) Flocculation: fine particles in suspension or as a layer on the bottom of the jar.
 - c) Clabbering: Thickening texture (coagulated) like gelatin.

MIXING INSTRUCTIONS

1. Fill spray tank with clean water 1/3 to 1/2 of desired level.
2. While agitating, add the required amount of *Cobra* Herbicide. Agitation should create a rippling or rolling action on the water surface. If tank mixing *Cobra* Herbicide with other labeled pesticides, add water soluble bags first, followed by dry formulations, flowables, emulsifiable concentrates and then solutions. Prepare no more spray mixture than is required for the immediate spray operation.
3. Add any required adjuvants.
4. Add any required nitrogen source, unless ammonium sulfate (AMS) is being used. If AMS is being used as the nitrogen source, it should be added after water soluble bags and before dry pesticides.
5. Fill spray tank to desired level with water. Agitation should continue until spray solution has been applied.
6. Mix only the amount of spray solution that can be applied the day of mixing. *Cobra* Herbicide will remain active in the spray solution for 12 hours.

APPLICATION EQUIPMENT

Application equipment should be clean and in good repair. Space nozzles uniformly on boom and frequently check for accuracy. Ground speed should not exceed 10 mph to provide proper spray coverage. Boom height, ground speed, and pressure recommendations, should not exceed those recommended by the spray nozzle manufacturer for the type and size of nozzle being used. Improper use of the selected spray nozzle will adversely affect the spray pattern, prevent proper coverage of weed leaf surface, and reduce weed control. Refer to the manufacturer's spray chart for nozzle selection and operating information. Give special attention to preparing and operating the spray equipment to assure proper coverage of weed foliage.

SPRAY DRIFT MANAGEMENT

Do not allow spray from ground or aerial equipment to drift onto adjacent land or crops. The interaction of many equipment and weather related factors determine the potential for spray drift. The applicator and the grower are responsible for considering all factors involved in minimizing drift potential.

BROADCAST APPLICATION

Do Not Use The Following Delivery Systems To Apply Cobra Herbicide:

- 1 – Flood nozzles
- 2 – Control Droplet Application (CDA)
- 3 – Flat fan nozzles larger than 8006
- 4 – Spray rigs which utilize wheel driven pumps

Apply *Cobra* Herbicide and *Cobra* Herbicide tank mixes with ground equipment using standard commercial sprayers equipped with flat fan (including split-nozzle systems which spray in opposite directions) or hollow cone nozzles designed to deliver the desired spray pressure and spray volume. Thorough weed coverage is required for optimum control. Center spray nozzles at a maximum of 20 inch spacing to provide adequate coverage.

Carrier Volume and Spray Pressure

Use *Cobra* Herbicide on a broadcast basis in a minimum of **10 gallons of water per acre** and a minimum spray pressure of **40 PSI measured at the boom**. *Cobra* Herbicide is a contact herbicide which requires coverage for optimal control. Valent recommends 20 gallons of water per acre when targeting weeds which are at the maximum labeled growth stage at application.

AERIAL APPLICATION

Spray drift away from the site of application may cause damage to non-target vegetation. To minimize drift, apply the largest droplet size consistent with uniform coverage and satisfactory weed control. To obtain satisfactory application and avoid drift, the following directions must be observed:

- Do not apply during low-level inversion conditions (including fog), when winds are gusty or under other conditions that favor drift. Do not spray when wind velocity is less than 2 mph or more than 10 mph.
- Do not apply this product by air within 200 ft of non-target plants including non-target crops.
- Do not apply this product by air within 200 ft of emerged cotton crops.
- Do not apply this product by air within 200 ft of streams, wetlands, marshes, ponds, lakes and reservoirs.
- **Carrier Volume and Spray Pressure:** When used as part of a burndown weed control program, apply *Cobra* Herbicide in 7 to 10 gals of water per acre. Application at less than 7 gals per acre may provide inadequate control. When used for preemergence weed control, apply *Cobra* Herbicide in 5 to 10 gals of water per acre. The higher gallonage applications generally afford more consistent weed control. Do not exceed the nozzle manufacturer's recommended pressures. For many nozzle types, lower pressure produces larger droplets. When higher flow rates are needed, use higher flow rate nozzles instead of increasing pressure.

- **Nozzle Selection and Orientation:** Formation of very small drops may be minimized by appropriate nozzle selection, by orienting nozzles away from the air stream as much as possible and by avoiding excessive spray pressure. Use nozzles that produce flat or hollow cone spray patterns. Use non-drip type nozzles, such as diaphragm type nozzles, to avoid unwanted discharge of spray solution. The nozzles must be directed toward the rear of the aircraft, at an angle between 0 and 15° downward. Do not place nozzles on the outer 25% of the wings or rotors.

Adjuvants and Drift Control Additives:

Drift control additives are not recommended with *Cobra* Herbicide.

Swath Adjustment

When applications are made with a cross wind, the swath will be displaced downwind. Therefore, on the up and downwind edges of the field, the applicator must compensate for this displacement by adjusting the path of the aircraft upwind. Swath adjustment distance should increase, with increasing drift potential (higher wind, smaller drops, etc.).

Wind

Variable wind speeds with changing directions may pose the largest potential for drift damage in areas that are adjacent to the field to be sprayed. Drift potential is lowest between wind speeds of 2 to 8 mph. However, many factors, including droplet size and equipment type determine drift potential at any given speed. Application should be avoided below 2 mph due to variable wind direction and high inversion potential. Note: Local terrain can influence wind patterns. Every applicator should be familiar with local wind patterns and how they affect drift.

Temperature and Humidity

When making applications in low relative humidity, set up equipment to produce larger droplets to compensate for evaporation but they still should remain within the medium droplet size category. Droplet evaporation is most severe when conditions are both hot and dry.

Temperature Inversions

Do not spray at times when spray particles may be entrained into a temperature inversion layer. If inversion conditions are suspected, consult with local weather services before making an application. Applications should not occur during temperature inversion, because drift potential is high. Temperature inversions restrict vertical air mixing, which causes small, suspended droplets to remain in a concentrated cloud. This cloud can move in unpredictable directions due to the light variable winds common during inversions. Temperature inversions are characterized by increasing temperatures with altitude and are common on nights with limited cloud cover and light to no wind. They begin to form as the sun sets and often continue into the morning. Their presence can be indicated by ground fog; however, if fog is not present, inversions can also be identified by the movement of smoke from a ground source or an aircraft smoke generator. Smoke that layers and moves laterally in a connected cloud (under low wind conditions) indicates an inversion, while smoke that moves upwards and rapidly dissipates indicates good vertical air mixing.

Sensitive Areas

The pesticide should only be applied when the potential for drift to adjacent sensitive areas (e.g., residential areas, bodies of water, known habitat for threatened or endangered species, non-target crops) is minimal (e.g., when wind is blowing away from the sensitive areas).

Do not apply during low-level inversion conditions, when winds are gusty or under any other condition that favors drift. Do not spray when drift is possible or when wind velocity is less than 2 or more than 10 mph.

Drift may cause damage to any vegetation contacted to which application is not intended. To prevent injury to adjacent desirable vegetation, appropriate buffer zones must be maintained.

Do not apply this product within 200 feet of non-target plants including non-target crops. Do not apply this product within 200 feet of streams, wetlands, marshes, ponds, lakes and reservoirs.

APPLICATION AND CULTIVATION

Do not cultivate prior to or during application. Do not generate excessive dust while spraying. Excessively dusty conditions may interfere with the coverage of the weed leaf surface by the spray solution. A timely cultivation approximately one week after application will assist in weed control.

SEQUENTIAL APPLICATIONS

A sequential application of *Cobra* Herbicide can be made after a minimum of 14 days have passed following the first application.

CROP FAILURE

If the crop treated with *Cobra* Herbicide is lost due to a catastrophe, such as hail or other forms of inclement weather, refer to crop Rotational Restrictions below.

ROTATIONAL RESTRICTIONS

Cobra Herbicide has no rotational restrictions.

DIRECTIONS FOR USE IN SOYBEANS

CROP INFORMATION

Apply *Cobra* Herbicide preplant, preemergence and/or postemergence.

RESTRICTIONS

Do not exceed a total of 25 fl oz (0.4 lb ai) per acre per year.

Do not apply within 45 days of harvest or after growth stage R6 (full seed).

NOTE: New York State Only – Apply *Cobra* Herbicide only as a postemergence herbicide once per year, at a maximum annual application rate not to exceed 12.5 fl oz (0.2 lb ai) per acre, and not later than 90 days before harvest.

Do not graze animals on green forage or stubble. Do not feed treated soybean silage (ensiled soybeans) to cattle. Do not utilize hay or straw for animal feed or bedding.

APPLICATION TIMING

Preplant

Cobra Herbicide may be applied as part of a burndown program to control emerged weeds listed in Table 2 prior to planting soybeans. *Cobra* Herbicide will control the weeds found in Table 2 if they are within the maximum leaf number and the maximum height.

Postemergence

Cobra Herbicide will control the weeds listed in Table 2 if they are within the maximum leaf number and the maximum height. For best results, *Cobra* Herbicide and *Cobra* Herbicide tank mixes should be applied to actively growing weeds. Use of a crop oil concentrate or a non-ionic surfactant is required. Refer to the label section on ADJUVANTS AND ADDITIVES for specific recommendation.

Table 2. Weeds Controlled by Postemergence Activity of *Cobra* Herbicide

RATE	COMMON NAME	SCIENTIFIC NAME	MAXIMUM LEAF NUMBER	MAXIMUM HEIGHT (INCHES)
8 fl oz/A*	Cocklebur, Common	<i>Xanthium strumarium</i>	4	3
	Jimsonweed	<i>Datura stramonium</i>	4	3
	Nightshade, Black	<i>Solanum nigrum</i>	4	4
	Pigweeds			
	Redroot	<i>Amaranthus retroflexus</i>	6	3
	Smooth	<i>Amaranthus hybridus</i>	6	3
10 fl oz/A*	Cocklebur, Common	<i>Xanthium strumarium</i>	5	4
	Jimsonweed	<i>Datura stramonium</i>	4	4
	Nightshade, Black	<i>Solanum nigrum</i>	5	4
	Kochia	<i>Kochia scoparia</i>	6	2
	Pigweeds			
	Redroot	<i>Amaranthus retroflexus</i>	6	4
	Palmer Amaranth*	<i>Amaranthus palmeri</i>	4	2
	Smooth	<i>Amaranthus hybridus</i>	6	4
	Ragweeds			
	Common	<i>Ambrosia artemisiifolia</i>	4	2
	Waterhemp			
	Common	<i>Amaranthus rudis</i>	4	2
	Tall	<i>Amaranthus tuberculatus</i>	4	2

continued

Table 2. Weeds Controlled By Postemergence Activity of Cobra Herbicide continued

RATE	COMMON NAME	SCIENTIFIC NAME	MAXIMUM LEAF NUMBER	MAXIMUM HEIGHT (INCHES)	
12.5 fl oz/A	Balloonvine	<i>Cardiospermum halicacabum</i>	4	4	
	Beggarticks, Devils	<i>Bidens frondosa</i>	6	4	
	Bristly Starbur	<i>Acanthospermum hispidum</i>	4	4	
	Buffalobur	<i>Solanum rostratum</i>	4	4	
	Burcucumber	<i>Sicyos angulatus</i>	4	4	
	Carpetweed	<i>Mollugo verticillata</i>	8" diameter		
	Common Cocklebur	<i>Xanthium strumarium</i>	6	4	
	Common Purslane	<i>Portulaca oleracea</i>	8" diameter		
	Copperleaf				
		Hophornbeam	<i>Acalypha ostryifolia</i>	6	4
		Virginia	<i>Acalypha virginica</i>	4	4
	Croton				
		Tropic	<i>Croton glandulosus</i> <i>var.septentrionalis</i>	4	4
		Woolly	<i>Croton capitatus</i>	4	4
		Devil's-claw	<i>Proboscidea louisianica</i>	4	4
		Eclipta	<i>Eclipta prostrata</i>	6	4
		Florida Beggarweed	<i>Desmodium tortuosum</i>	2	4
		Florida Pusley	<i>Richardia scabra</i>	6	4
	Groundcherry				
		Cutleaf	<i>Physalis angulata</i>	6	4
		Lanceleaf		6	-
		Hairy Galinsoga	<i>Galinsoga quadriradiata</i>	4	4
		Hemp Sesbania	<i>Sesbania herbacea</i>	6	4
		Jimsonweed	<i>Datura stramonium</i>	4	4
		Kochia	<i>Kochia scoparia</i>	6	2
		Lanceleaf Sage	<i>Salvia reflexa</i>	4	4
		Texasweed	<i>Caperonia palustris</i>	4	4
	Morningglories				
		Cypressvine	<i>Ipomoea quamoclit</i>	4	3
		Entireleaf*	<i>Ipomoea hederacea var.</i> <i>integriuscula</i>	4	3
		Ivyleaf*	<i>Ipomoea hederacea</i>	4	3
		Palmleaf*	<i>Ipomoea wrightii</i>	4	3
		Pitted*	<i>Ipomoea lacunosa</i>	4	3
		Purple Moonflower*	<i>Ipomoea turbinata</i>	4	3
		Smallflower*	<i>Jacquemontia tamnifolia</i>	4	3
		Tall*	<i>Ipomoea purpurea</i>	4	3
		Mustard, Wild	<i>Sinapis arvensis</i>	6	4
	Nightshades				
		Black	<i>Solanum nigrum</i>	6	5
		Eastern Black	<i>Solanum ptychanthum</i>	6	5
		Hairy	<i>Solanum physalifolium</i>	4	5

continued

Table 2. Weeds Controlled By Postemergence Activity of Cobra Herbicide continued

Rate	COMMON NAME	SCIENTIFIC NAME	Maximum Leaf Number	Maximum Height (Inches)
12.5 fl oz/A	Pigweeds			
	Palmer Amaranth*	<i>Amaranthus palmeri</i>	6	3
	Prostrate	<i>Amaranthus blitoides</i>	6	4
	Redroot	<i>Amaranthus retroflexus</i>	6	4
	Smooth	<i>Amaranthus hybridus</i>	6	4
	Spiny Amaranth	<i>Amaranthus spinosus</i>	6	4
	Poorjoe	<i>Diodia teres</i>	6	3
	Prickly Sida (Teaweed)	<i>Sida spinosa</i>	4	3
	Puncturevine	<i>Tribulus terrestris</i>	1.5 inch diameter	
	Ragweeds			
	Common	<i>Ambrosia artemisiifolia</i>	6	4
	Giant	<i>Ambrosia trifida</i>	4	2
	Showy Crotalaria	<i>Crotalaria spectabilis</i>	4	4
	Smellmelon	<i>Cucumis melo</i>	6	4
	Sunflower, Common*	<i>Helianthus annuus</i>	2	4
	Spurge			
	Prostrate	<i>Chamaesyce maculata</i>	1.5 inch diameter	
	Spotted	<i>Chamaesyce maculata</i>	4	4
	Toothed	<i>Euphorbia dentate</i>	4	4
	Venice Mallow	<i>Hibiscus trionum</i>	4	4
	Waterhemp*			
	Common	<i>Amaranthus rudis</i>	6	3
	Tall	<i>Amaranthus tuberculatus</i>	6	3
	Wild Poinsettia	<i>Euphorbia heterophylla</i>	4	4
	Witchweed	<i>Striga asiatica</i>	6 to 8 inches and prior to bloom	

*Crop oil concentrate (COC) is required for control. The addition of liquid nitrogen (28, 30 or 32%) or ammonium sulfate in combination with COC may enhance weed control.

Table 3. Weeds Suppressed by Postemergence Activity of Cobra Herbicide

Rate	Common Name	Scientific Name	Maximum Leaf Number
12.5 fl oz /A	Coffee Senna*	<i>Senna occidentalis</i>	2
	Canada Thistle	<i>Cirsium arvense</i>	6
	Milkweed		
	Climbing	<i>Funastrum cynanchoides</i>	6
	Common	<i>Asclepias syriaca</i>	6
	Morningglory		
	Bigroot (Wild Sweet Potato)	<i>Ipomoea pandurata</i>	6
	Redvine	<i>Brunnichia ovate</i>	6
	Smartweed, Swamp	<i>Polgonum amphibium</i>	6
	Trumpetcreeper	<i>Campsis radicans</i>	6
	Smartweed, Pennsylvania	<i>Polygonum pennsylvanicum</i>	4
	Spurred Anoda	<i>Anoda cristata</i>	2
	Velvetleaf*	<i>Abutilon theophrasti</i>	4

*Crop oil concentrate (COC) is required for suppression. The addition of liquid nitrogen (28, 30 or 32%) or ammonium sulfate in combination with COC may enhance weed control.

If any of the weeds listed in Table 2 have been previously treated with a postemergence herbicide, the efficacy of *Cobra* Herbicide may be reduced because those weeds may be under a herbicide stress.

TANK MIX PARTNERS FOR USE IN SOYBEANS – PREPLANT/PREEMERGENCE APPLICATION

Cobra Herbicide can be tank mixed with the following soybean herbicides listed in Table 4. Refer to tank mix partner's label for additional use instructions and restrictions. Follow the most restrictive label limitations, precautions and restrictions from both herbicide labels.

Table 4. Tank Mix Partners for Cobra Herbicide for Preplant/Preemergence Application in Soybean

2,4-D	Gangster®	Resource®
2,4-DB	glufosinate (Liberty® 280 SL Herbicide)	Roundup® Power Max®
Basagran®	glyphosate	Roundup® Weather Max®
Classic®	Harmony® SG	Scepter®
Dual® II Magnum	IntRRo®	Select Max®
Fierce®	Outlook®	Surveil®
FirstRate®	Pursuit®	Valor®
fluazifop (Fusilade® DX)	quizalofop-p-ethyl (Assure® II)	Valor® XLT
flumioxazin	Raptor®	Warrant®

Preemergence

Cobra Herbicide may be utilized as a preemergence soil applied herbicide for control of annual broadleaf weeds in soybeans. Preemergence applications of *Cobra* Herbicide will provide approximately two weeks of residual control of the weeds listed in Table 5.

Do not apply more than 19 fl oz/A (0.3 lb ai) preemergence per acre per year.

Table 5. Weeds Controlled by Preemergence Activity of *Cobra* Herbicide

Rate	Common Name	Scientific Name
12.5 to 15 fl oz/A	Nightshade	
	Black	<i>Solanum nigrum</i>
	Eastern Black	<i>Solanum ptychanthum</i>
	Pigweed	
	Redroot	<i>Amaranthus retroflexus</i>
	Smooth	<i>Amaranthus hybridus</i>
15 to 19 fl oz/A	Copperleaf	
	Hophornbeam	<i>Acalypha ostryifolia</i>
	Virginia	<i>Acalypha virginica</i>
	Lambsquarters, Common	<i>Chenopodium album</i>
	Nightshade	
	Black	<i>Solanum nigrum</i>
	Eastern Black	<i>Solanum ptychanthum</i>
	Pigweed	
	Redroot	<i>Amaranthus retroflexus</i>
	Smooth	<i>Amaranthus hybridus</i>
	Ragweed, Common	<i>Ambrosia artemisiifolia</i>
	Waterhemp	
	Common	<i>Amaranthus rudis</i>
	Tall	<i>Amaranthus tuberculatus</i>

TANK MIX PARTNERS FOR USE IN SOYBEANS - POSTEMERGENCE APPLICATION

Cobra Herbicide can be tank mixed with the following soybean herbicides listed in Table 6. Refer to tank mix partner’s label for additional use instructions and restrictions. Follow the most restrictive label limitations, precautions and restrictions from both herbicide labels.

Table 6. Tank Mix Partners for *Cobra* Herbicide for Postemergence Application in Soybean

2,4-DB	glyphosate	<i>Resource</i>
Basagran	Harmony SG	Roundup PowerMAX
Classic	IntRRo	Roundup WeatherMAX
Dual II Magnum	Outlook	Scepter
FirstRate	Pursuit	<i>Select Max</i>
fluazifop (Fusilade DX)	quizalofop-p-ethyl (Assure II)	Warrant
glufosinate (Liberty 280 SL Herbicide)	Raptor	

Applying *Cobra* Herbicide under conditions that do not promote active weed growth will reduce herbicide effectiveness. These conditions include drought, excessive water, extremes in temperatures, previous postemergence herbicide treatments, and low humidity. Weeds under stress tend to “harden off” and become less susceptible to herbicidal action.

Do not cultivate prior to or during application. Do not generate excessive dust while spraying. Excessively dusty conditions may interfere with the coverage of the weed leaf surface by the spray solution. A timely cultivation approximately one week after application will assist in weed control.

Disease Suppression

A postemergence application of *Cobra* Herbicide to soybeans can suppress white mold caused by *Sclerotinia sclerotiorum* [as well as Sudden Death Syndrome caused by *Fusarium virguliforme*].

Table 7. Disease Suppression by *Cobra* Herbicide

Rate	Common Name	Soybean Growth Stage	Adjuvant Recommendation
6 to 12.5 fl oz/A	White Mold (<i>Sclerotinia stem rot</i>) [Sudden Death Syndrome (<i>Fusarium vrguliforme</i>)]	Application of <i>Cobra</i> Herbicide must be made at, or just before, R2 (full bloom).	Crop Oil Concentrate or Methylated Seed Oil 1.0 pt/A or Non-ionic Surfactant 0.25% v/v
NOTE: It has been shown that the effects of <i>Cobra</i> Herbicide on white mold is not a fungicidal response but one that may involve Systemic Acquired Resistance (SAR).			

PRECAUTION: Apply *Cobra* Herbicide prior to infection and before soybeans are past R2 (full bloom).

DIRECTIONS FOR USE IN COTTON

CROP INFORMATION

Cobra Herbicide may be applied as a post-directed or layby application for postemergence weed control.

RESTRICTIONS

- Do not apply more than 12.5 fl oz/A (0.20 lb ai/A) of *Cobra* Herbicide per application.
- Do not exceed a combined rate of 25 fl oz/A (0.40 lb ai/A) of *Cobra* Herbicide per year.
- Do not make a sequential application of *Cobra* Herbicide within 14 days of the first application.
- Do not make more than two (2) *Cobra* Herbicide applications per year.
- Do not apply *Cobra* Herbicide to cotton within 70 days before harvest.
- Do not graze animals on green forage or stubble.
- Do not utilize hay or straw for animal feed or bedding.
- Do not apply *Cobra* Herbicide over the top of cotton.

LIMITATIONS

Apply *Cobra* Herbicide postemergence as a directed spray application following a preplant incorporated or preemergence herbicide(s) for early season control of grasses and broadleaf weeds. Use *Cobra* Herbicide as a postemergence directed application when the cotton plant has reached a minimum height of 6 inches and a height difference of 3 to 5 inches has been established between the lower leaves of the cotton plant and the top of the broadleaf weeds.

Layby applications of *Cobra* Herbicide will control broadleaf weeds that do not exceed leaf stage recommendations listed in Table 2 of this label. Refer to the label section on TANK MIX PARTNERS FOR USE IN COTTON for specific recommendations. Use of a crop oil concentrate or a non-ionic surfactant is required.

TANK MIX PARTNERS FOR USE IN COTTON

Cobra Herbicide can be tank mixed with the following cotton herbicides listed in Table 8. Refer to tank mix partner for additional use instructions and restrictions

Table 8. Tank Mix Partners for *Cobra* Herbicide Layby Application in Cotton

Caparol [®]	Ignite [®]	<i>Select Max</i>
Cotoran [®]	linuron	S-metolachlor
diuron	MSMA	<i>Valor</i>
Envoke [®]	Roundup PowerMAX	Warrant
glyphosate	Roundup WeatherMAX	--

COTTON TOLERANCE

Apply *Cobra* Herbicide to cotton **ONLY** as a **DIRECTED SPRAY** application with nozzles set to deliver the spray mixture toward the base of the cotton plant, as specified in the “Timing” and “Application” sections of this label. Lower leaves which are contacted by the spray mixture will appear spotted or light brown to bronze in color. This response will have no effect on the growth or development of the cotton crop, and all growth following application will be normal.

It is essential to establish a height differential of 3 to 5 inches between the crop and the target weeds prior to application to ensure full coverage of the weed leaf surfaces while minimizing direct contact of the spray mixture with the upper leaves and terminal area of the cotton plant.

Cobra Herbicide is a contact herbicide. It does not move throughout the cotton plant and it will not vaporize off the soil surface.

TIMING

Post-Directed: Cotton 6” or more - For best results, *Cobra* Herbicide should be applied to small, actively growing weeds. Nozzle should be set to spray no higher than the bottom 2 to 3 inches of the cotton stalk (or the top of the bark formation) and still fully cover the target weeds. A properly timed directed spray application will provide control of labeled weeds not larger than indicated in Table 2.

Layby: Cotton 12” or more - Nozzles should be set to spray no higher than the bottom 1/3 of the cotton stalk (up to the first fruiting node) and still fully cover the target weeds. Use of tank mix combinations will provide better control of larger late season troublesome weeds in cotton.

CULTIVATION

When postemergence directing *Cobra* Herbicide at the same time as cultivation, the spray nozzles must be positioned in front of the cultivation equipment. Applying *Cobra* Herbicide at the time of cultivation under dry soil conditions will cause excessive dust which will prevent proper contact between *Cobra* Herbicide and the weed surface. This reduced contact will decrease weed control activity. In addition, applying *Cobra* Herbicide while cultivating at ground speeds greater than 5 mph will prevent good coverage of the weed surface by the spray solution and reduce weed control activity.

APPLICATION RATES

***Cobra* Herbicide Applied Alone:** Apply *Cobra* Herbicide at a rate of 12.5 fl oz per acre on a broadcast basis. The sprayer must be equipped with flat fan or off-center fan nozzles designed to deliver 10 to 30 gals of water per acre when operated at a spray pressure of 20 to 30 PSI measured at the nozzle. Pressures greater than 30 PSI may cause the spray mist to move upward into the cotton canopy resulting in severe crop injury.

ADJUVANTS

The use of recommended adjuvants has consistently enhanced weed control over a wide range of application conditions.

For post-directed application of *Cobra* Herbicide to cotton at least 6” tall, use either a non-ionic surfactant at 0.25% v/v; **OR** crop oil concentrate at 1 pt per acre (broadcast basis), if bark formation has begun.

For Layby application of *Cobra* Herbicide to cotton 12” tall (or more), use a crop oil concentrate at 1 to 2 pts per acre (broadcast basis).

Table 9. Adjuvant Recommendations for Use in Cotton

Adjuvant	Post-Directed	Layby
Non-Ionic Surfactant (NIS)	0.25% v/v	Not Recommended
Crop Oil Concentrate (COC)/Acre	1 pt/A*	1 to 2 pt/A

*Only use COC during a post directed application if bark formation has begun

DIRECTIONS FOR USE IN PEANUTS

CROP INFORMATION

Cobra Herbicide effectively controls a wide spectrum of important broadleaf weeds in peanuts. Weeds can be controlled by applying *Cobra* Herbicide postemergence to actively growing weeds no larger than sizes indicated in Table 2.

RESTRICTIONS

- Do not apply more than 12.5 fl oz/A (0.2 lb ai/A) of *Cobra* Herbicide per application.
- Do not exceed a combined rate of 25 fl oz/A (0.4 lb ai/A) of *Cobra* Herbicide per year.
- Do not make a sequential application of *Cobra* Herbicide within 14 days of the first application.
- Do not make more than two (2) *Cobra* Herbicide applications per year.
- Do not apply *Cobra* Herbicide to peanuts later than 45 days before harvest.
- Do not allow livestock to graze treated foliage.
- Do not use treated vines for feed or forage.

EARLY POSTEMERGENCE TREATMENT

A single early postemergence treatment of *Cobra* Herbicide at 12.5 fl oz per acre may be made to control emerged broadleaf weeds. Apply after the peanuts have at least 6 true leaves. A second postemergence application of *Cobra* Herbicide at 12.5 fl oz per acre may be made to control later emerging weeds or weeds escaping the first application as long as they are still within the labeled growth stage.

ADJUVANTS AND ADDITIVES

Refer to Table 1 in ADJUVANTS AND ADDITIVES section for adjuvant recommendations.

CROP TOLERANCE

Peanuts with 6 or more emerged true leaves are very tolerant to postemergence *Cobra* Herbicide applications. Mature peanut leaves treated with *Cobra* Herbicide will show some brown speckling and bronzing. Growth of the next 2 true leaves may show some cupping or crinkling of the leaf margins. Subsequent growth will be normal and peanuts quickly outgrow this temporary condition.

TANK MIX PARTNERS FOR USE IN PEANUTS

Cobra Herbicide can be tank mixed with the following peanut herbicides listed in Table 10. Refer to tank mix partner for additional use instructions and restrictions.

Table 10. Tank Mix Partners for *Cobra* Herbicide for Postemergence Application in Peanuts

2,4-DB*	Classic	Outlook
Basagran	Dual II Magnum	Pursuit
Cadre [®]	IntRRo	<i>Select Max</i>

*Use only 2,4-DB formulations approved for postemergence use in peanuts. Add a crop oil concentrate at 1.0 to 2.0 pt/A or a non-ionic surfactant at 0.25% v/v to this mixture. Follow all 2,4-DB label restrictions relative to drift onto sensitive crops.

DIRECTIONS FOR OUTDOOR USE IN CONIFER SEEDLINGS AND CONIFER NURSERIES

CROP INFORMATION

Cobra Herbicide is a selective herbicide for outdoor use on and around conifer seedlings when used according to this label. *Cobra* Herbicide works primarily through contact activity. *Cobra* Herbicide may be used on the tolerant conifer species listed below.

Cobra Herbicide may be applied for preemergence and/or postemergence broadleaf weed control in conifer seedbeds, container grown conifers, seedling transplants and conifer plantations (but not in forests).

IMPORTANT

- Occasionally slight needle burn may be observed on the youngest growth following application. New growth will be normal and the seedlings will continue vigorous growth under favorable environmental conditions.
- Plant tolerance to *Cobra* Herbicide at labeled rates has been found to be acceptable for the indicated genera and species listed below. Due to variability within species, crop growth stage, environmental conditions, and application techniques, it is recommended that the user determine if herbicide can be used safely on a few plants prior to widespread application. Neither the seller nor the manufacturer of *Cobra* Herbicide have investigated the safety factor to plants not listed on the label.

CONIFER SPECIES

Cobra Herbicide may be applied to conifer seedbeds of numerous species including the following:

Common Name	Scientific Name
Fir	
Douglas	<i>Pseudotsuga menziesii</i>
Fraser	<i>Abies fraseri</i>
Grand	<i>Abies grandis</i>
Noble	<i>Abies procera</i>
Hemlock	
Eastern	<i>Tsuga canadensis</i>
Western	<i>Tsuga heterophylla</i>
Pine	
Eastern White	<i>Pinus strobes</i>
Jack	<i>Pinus banksiana</i>
Loblolly	<i>Pinus taeda</i>
Lodgepole	<i>Pinus contorta</i>
Longleaf	<i>Pinus palustris</i>
Ponderosa	<i>Pinus ponderosa</i>
Sand	<i>Pinus clausa</i>
Scotch	<i>Pinus sylvestris</i>
Shortleaf	<i>Pinus echinata</i>
Slash	<i>Pinus elliotii</i>
Virginia	<i>Pinus Virginiana</i>
Spruce	
Blue	<i>Picea pungens</i>
Dwarf Alberta	<i>Picea glauca conica</i>
Norway	<i>Picea abies</i>
Sitka	<i>Picea sitchensis</i>

PREEMERGENCE APPLICATION

Preemergence application of *Cobra* Herbicide should be made to tilled, weed free, planted seedbeds or to weed-free container grown seedlings after sowing but prior to seedling emergence. *Cobra* Herbicide may be incorporated with 0.25 to 0.5 inch water following application and before conifer seedling emergence. A preemergence (to weeds) application of *Cobra* Herbicide may be sprayed directly over conifers recently transplanted providing bud break has not yet occurred. Do not mechanically incorporate *Cobra* Herbicide. After preemergence application of *Cobra* Herbicide to seedbeds, soil should not be disturbed because herbicidal effectiveness will be decreased. *Cobra* Herbicide may be used as a preemergence application to conifers, when used as directed in Table 11.

Table 11. Preemergence Applications to Conifer Seedlings

Cobra Herbicide Rates	Adjuvant	Weeds Controlled
8 to 16 fl oz/A (0.125 – 0.25 lb ai/A)	None	Clover (<i>Trifolium</i> spp.)
		Common Chickweed
		Common Groundsel
		Common Purslane
		Common Ragweed
		Cottonwood (<i>Populus</i> spp.)
		Lambsquarters
		Mustard species
		Nightshade species
		Pearlwort
		Pigweed species
		Pineapple weed
		Sowthistle
		Spurge
		Prostrate
Spotted		
Willow (<i>Salix</i> spp.)		

POSTEMERGENCE APPLICATION

Postemergence applications of *Cobra* Herbicide should be made when weeds are actively growing and no larger than 4 inches in height. *Cobra* Herbicide works primarily through contact activity. Conifer seedlings will tolerate postemergence treatments when applications are made following complete stand emergence and when the primary shoot growth is complete and has hardened off. Some forking and stunting of seedling may result if *Cobra* Herbicide is applied to newly emerged seedlings. Conifer transplants will tolerate postemergence treatments when applications are made before bud break or after foliage has had an opportunity to harden off. Occasionally slight needle burn will be observed on the youngest conifer growth following application. New growth will not be adversely affected and conifers will continue vigorous growth under favorable environmental conditions. *Cobra* Herbicide may be used in postemergence applications to conifers, when used as directed in Table 12.

Table 12. Postemergence Applications to Conifer Seedlings

Cobra Herbicide Rates	Adjuvant	Weeds Controlled (up to 4 inches)
6.5 to 16 fl oz/A* (0.10 – 0.25 lb ai/A)	0.25% v/v non-ionic surfactant or 0.125 % v/v crop oil concentrate**	Carpetweed
		Clover (<i>Trifolium</i> spp.)
		Common Chickweed
		Common Dayflower
		Common Groundsel
		Common Purslane
		Common Ragweed
		Cottonwood (<i>Populus</i> spp.)
		Dogfennel
		Eclipta
		Florida Beggarweed
		Florida Pusley
		Hairy Galinsoga
		Mayweed
		Morningglory species
		Mustard species
		Nightshade species
		Pearlwort
		Pigweed species
		Pineapple weed
		Poorjoe
		Prickly Sida
		Showy Crotalaria
		Sowthistle
		Spurge
		Prostrate
Spotted		
Tropic Croton		
Willow (<i>Salix</i> spp.)		
Witchweed		
Yellow Woodsorrel		
* Four applications at weekly intervals of 6.5 fl oz/A or two applications at two week intervals of 13 fl oz/A are recommended for Southern Pine species only.		
**Crop oil concentrate has been proven safe only in Southern Pine conifer species (after primary shoot growth has begun).		

APPLICATION INSTRUCTIONS

Thoroughly mix *Cobra* Herbicide with clean water and apply at a minimum of 30 PSI in minimum of 20 gals per acre. Flat fan or hollow cone nozzles are recommended. Applications made at less than 20 gals per acre or less than 30 PSI will not provide complete coverage of the weeds and will result in incomplete weed control.

Care should be taken to ensure your nursery species are tolerant to *Cobra* Herbicide applications. In each nursery it is suggested that *Cobra* Herbicide be tested on each species in limited areas prior to an operational application.

USE RESTRICTIONS FOR COBRA HERBICIDE IN CONIFER SEEDLINGS

1. Do not apply *Cobra* Herbicide when conifers are under stress from diseases, animal or winter injury, planting shock or other stresses.
2. The total amount of *Cobra* Herbicide used per year must not exceed 26 fl oz/A.
3. **Do not apply *Cobra* Herbicide with spray adjuvants while conifer shoot growth is young and has not hardened off.**

DIRECTIONS FOR POST-DIRECTED APPLICATION IN KENAF

CROP INFORMATION

Cobra Herbicide is a broad spectrum contact herbicide for postemergence directed control of broadleaf weeds in kenaf. Apply *Cobra* Herbicide postemergence as a directed spray application following a preplant incorporated or preemergence herbicide(s) for early season control of grasses and broadleaf weeds. Use *Cobra* Herbicide as a postemergence directed application when the kenaf plant has reached a minimum height of 10 inches and a height difference of 3 to 5 inches has been established between the lower leaves of the kenaf plant and the top of the broadleaf weeds. Make one (1) application per year.

Misapplication resulting in *Cobra* Herbicide coming into contact with the kenaf plant may result in injury of kenaf plants.

The postemergence directed applications of *Cobra* Herbicide or *Cobra* Herbicide tank mixes should use equipment designed to minimize spray solution contacting the kenaf plant. This equipment would include spray nozzles positioned a minimum of 3 inches above the soil surface and angled backward so that the spray solution discharges to the rear and underneath the row canopy, nozzles as described above with leaf lifters or shields and/or plastic preformed hooded sprayers positioned to run between the kenaf rows, all of which are designed to help reduce spray contact with the kenaf plant.

KENAF TOLERANCE

Apply *Cobra* Herbicide to kenaf **ONLY** as a **DIRECTED SPRAY** application with nozzles set to deliver the spray mixture toward the base of the kenaf plant, as specified in the "Timing" and "Application" sections of this label. Lower leaves which are contacted by the spray mixture will appear spotted or light brown to bronze in color. This response will have no effect on the growth or development of the kenaf crop, and all growth following application will be normal.

It is essential to establish a height differential of 3 to 5 inches between the crop and the target weeds prior to application to ensure full coverage of the weed leaf surfaces while minimizing direct contact of the spray mixture with the upper leaves and terminal area of the kenaf plant.

Cobra Herbicide is a contact herbicide. It does not move throughout the kenaf plant and it will not vaporize off the soil surface.

DO NOT apply *Cobra* Herbicide **OVER-THE-TOP** of kenaf.

TIMING

Post-Directed: KENAF 10" or More - For best results, apply *Cobra* Herbicide to small, actively growing weeds. Set nozzles to spray no higher than the bottom 2 to 3 inches of the kenaf stalk and still fully cover the target weeds. A properly timed directed spray application will provide control of labeled weeds not larger than indicated in Table 2.

DIRECTED BAND APPLICATION

Directed row banding is required for use of *Cobra* Herbicide in kenaf. Two nozzles per row, one on each side, are required for postemergence directed application. Tractor ground speed should not exceed 5 mph. The spray equipment used should accurately direct the spray pattern to the base of the kenaf plant to minimize contact with the kenaf plant and provide good coverage of the target weeds. Spray nozzles should be positioned a minimum of 3 inches above the soil surface and angled backward so that the spray solution discharges to the rear and under the row canopy. The use of leaf lifters or shields on application equipment is recommended to help reduce spray contact with the kenaf plant. Row banding equipment should be adjusted to provide maximum coverage of weeds in the banding area.

CULTIVATION

When postemergence directing *Cobra* Herbicide at the same time as cultivation, the spray nozzle must be positioned in front of the cultivation equipment. Applying *Cobra* Herbicide at the time of cultivation under dry soil conditions will cause excessive dust which will prevent proper contact between *Cobra* Herbicide and the weed surface. This reduced contact will decrease weed control activity. In addition, applying *Cobra* Herbicide while cultivating at ground speeds greater than 5 mph will prevent good coverage of the weed surface by the spray solution and reduce weed control activity.

APPLICATION RATES

Apply *Cobra* Herbicide at a rate of 12.5 fl oz per acre on a broadcast basis. The sprayer must be equipped with flat fan or off-center fan nozzles designed to deliver a minimum of 10 gallons of water per acre when operated at a minimum spray pressure of 20 PSI measured at the nozzle. Pressures greater than 30 PSI may cause the spray mist to move upward into the kenaf canopy resulting in severe crop injury. Refer to Table 13 for adjuvant recommendations.

Table 13. *Cobra* Herbicide Rates Post-Directed: KENAF

Application Timing	Broadcast Rate/Acre	Adjuvant*	Weeds	Comments
Post-directed: KENAF 10" or more	12.5 fl oz	1% v/v Crop Oil Concentrate (COC)	Refer to Table 2	Reduce broadcast rate in proportion to band area actually treated (See SPRAYER CALIBRATION).

*The use of spray adjuvants will provide enhanced control of broadleaf weeds.

STORAGE AND DISPOSAL

Do not contaminate water, food, or feed by storage, disposal or cleaning of equipment.

PESTICIDE STORAGE

Store in cool, dry place.

Keep pesticide in original container.

Do not put concentrate or dilute into food or drink containers.

Not for use or storage in or around the home.

For help with any spill, leak, fire or exposure involving this material call day or night
1-800-892-0099.

PESTICIDE DISPOSAL

This product is acutely hazardous. Improper disposal of excess pesticide, spray mixture, or rinsate is a violation of Federal law. If these wastes cannot be disposed of by use according to label instructions, contact your State Pesticide or Environmental Control Agency, or the Hazardous Waste representative at the nearest EPA Regional Office for guidance.

CONTAINER HANDLING

Note to EPA reviewer: if this product is shipped in containers less than 50 gallons, the following container handling statement will be added to the label:

[Nonrefillable container. Do not reuse or refill this container. Clean container promptly after emptying. Triple rinse as follows: Empty the remaining contents into application equipment or a mix tank and drain for 10 seconds after the flow begins to drip. Fill the container 1/4 full with water and recap. Shake for 10 seconds. Pour rinsate into application equipment or a mix tank or store rinsate for later use or disposal. Drain for 10 seconds after the flow begins to drip. Repeat this procedure two more times. Offer for recycling or reconditioning, or puncture and dispose of in a sanitary landfill, or incineration, or, if allowed by state and local authorities, by burning. If burned, stay out of smoke.]

Note to EPA reviewer: if this product is shipped in containers greater than 50 gallons, the following container handling statement will be added to the label:

[Nonrefillable container. Do not reuse or refill this container. Cleaning the container before final disposal is the responsibility of the person disposing of the container. Cleaning before refilling is the responsibility of the refiller. To clean the container before final disposal, empty the remaining contents from this container into application equipment or mix tank. Fill the container about 10 percent full with water. Agitate vigorously or recirculate water with the pump for 2 minutes. Pour or pump rinsate into application equipment or rinsate collection system. Repeat this rinsing procedure two more times. Offer for recycling, if available; otherwise dispose of in a sanitary landfill.]

©2015 Valent U.S.A. Corporation

Cobra, Fierce, Gangster, Resource, Select Max and *Valor* are registered trademarks of Valent U.S.A. Corporation

Assure, Classic and Harmony are registered trademarks of E. I. du Pont de Nemours and Company

Basagran, Cadre, Outlook, Pursuit, Raptor and Scepter are registered trademarks of BASF

Cotoran is a registered trademark of Griffin LLC

Caparol, Dual II Magnum, Envoke, Flexstar, Fusilade and Reflex are registered trademarks of Syngenta

FirstRate and Surveil are registered trademarks of Dow AgroSciences LLC

Ignite and Liberty are registered trademarks of Bayer

IntRRo, Roundup PowerMAX, Roundup Ready PLUS, Roundup WeatherMAX and Warrant are registered trademarks of Monsanto Company

Ultra Blazer is a registered trademark of United Phosphorus, Inc.

Manufactured for:

Valent U.S.A. Corporation

P. O. Box 8025

Walnut Creek, CA 94596-8025

Made in U.S.A.

EPA Reg. No. 59639-34

EPA Est. No.

059639-00034.20151012.COB.AMEND

THE VALENT RETURNABLE KEG

Description: This keg is a closed-system, refillable container designed for easy handling and convenient dispensing of product with no container disposal.

Construction: The keg is made of all stainless steel. Both the gaskets and seals are Viton and are compatible with the Valent product.

Pump System: With the versatility of the keg, either a mechanical pump or an air pressure system may be used to dispense the product.

Coupler: A specific dry-disconnect coupler is required for dispensing product from the keg. This coupler is available through local agricultural equipment suppliers.

Container Capacity: 15 gallons or 56.7 liters (by weight)

ATTENTION!

This is a closed-system container. Do not try to remove the valve from the keg. The coupler required for removal of product is available from local agricultural equipment suppliers. The keg contains tamper evident seals that, if broken, will incur a fee for the user of the keg. Both the coupler and the valve are designed for one-way operation only. Never try to pump any type of material back into the keg.

DIRECTIONS FOR USE

The proper coupler must be attached and engaged before removing any product from the keg. Either a mechanical pump or an air pressure system may be used and connected to the 1-inch NPT thread on the top of the coupler.

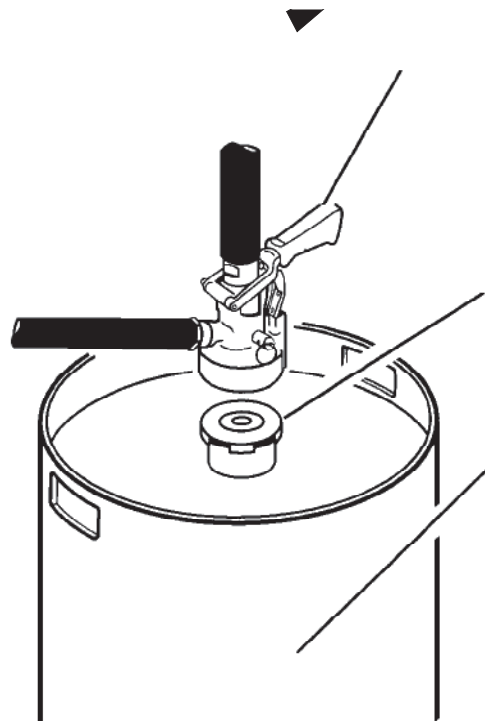

IMPORTANT! Attach a hose or pump to the coupler before engaging coupler. This will prevent the user from being splashed in the event that pressure build-up in the keg forces liquid up through the coupler.

To attach and engage the coupler:

1. Pull top of black dust cover back to expose head of valve. The bottom ring of the black dust cover will still be attached to the neck of the valve. Save the dust cover for reuse when returning keg.
2. Before engaging the coupler, securely attach a hose or pump to the threaded connection.
3. Twist coupler onto valve on keg.
and engage coupler by pulling handle straight out to unlock and then pushing handle down into lower position to open internal valve. Handle will automatically lock in place.
4. Secure and engage coupler by pulling handle straight out to unlock and then pushing handle down into lower position to open internal valve. Handle will automatically lock in place.
5. You are now ready to begin the pumping operation.

To remove coupler from container:

1. Release coupler by pulling handle straight out to unlock and then lifting handle into upper position. Handle will automatically lock in place.
2. Lift coupler from keg. As coupler clears top of valve, pull coupler sideways and lift it off the valve.
3. Wipe valve off and replace dust cover.
4. Flush coupler with water.
5. Wipe coupler and store in a clean place.
6. Properly dispose of cleaning towels and rinsate.

RETURNING KEGS

Clean the outside of the keg with water or soap before returning the keg to the distributor. Leave all Valent product labels and stickers securely attached. All Valent product labels, stickers and other information must remain on the keg in order to comply with both State and Federal regulations.

All Valent kegs are tracked using the individual keg serial number stamped in the top of the keg. Distributors are responsible for these kegs that have been assigned to them. Return this keg to the distributor from which it was purchased. Notify the distributor if the keg cannot be returned by the specific time.

Valent U.S.A. Corporation
1600 Riviera Avenue, Suite 200
Walnut Creek, CA 94596-8025

Valent U.S.A. Corporation
P. O. Box 8025
Walnut Creek, CA 94596-8025