

10F70
Pm21
46946-194



ca. expanded, for the pesticide
No. 148-1114

CHEMSTOR

**LIQUID PRESERVATIVE FOR HIGH MOISTURE CORN, SORGHUM,
WHEAT, OATS, BARLEY, GRASS FORAGE AND LEGUME FORAGE**

TO BE USED IN ANIMAL FEED ONLY

**DANGER:
CAUSES SEVERE BURNS**

KEEP OUT OF REACH OF CHILDREN

ACTIVE INGREDIENTS:

Organic Acids 99% Min. (19% Acetic and 80% Propionic)

INERT INGREDIENTS:

(Water) 1% Max.

ChemStor® is a Trademark of Celanese Corporation under License to Thompson-Hayward.

EPA Reg. No. 148-1114

CG-4-75

Do not get liquid or vapor in eyes, on skin, or clothing. Use in well ventilated area and do not inhale. Wear goggles, rubber gloves and protective clothing when handling ChemStor®. Do not use, pour, spill, or store near heat or open flame. In case of contact, immediately flush skin or eyes with plenty of water for at least 15 minutes. For eyes, get medical attention. After contents have been removed, drums should be washed and completely drained. Do not contaminate water by cleaning of equipment, or disposal of wastes.

**IMPORTANT: BEFORE USE SEE MANUFACTURERS
TECHNICAL BULLETIN FOR DIRECTIONS
AND OTHER CAUTIONS**

WARRANTIES: Apart from the representations in the ChemStor® Product and Technical Bulletins, there's NO WARRANTY, representation or condition of ANY KIND, expressed or implied (including NO WARRANTY OF MERCHANTABILITY) concerning material sold hereunder or containers in which shipped. Thompson-Hayward shall have no responsibility, whether for breach of warranty, negligence, or otherwise, for any loss, damage or injury to persons or property arising out of the use, storage or handling of ChemStor® otherwise than in strict accordance with the directions contained in the ChemStor® Technical Bulletin.

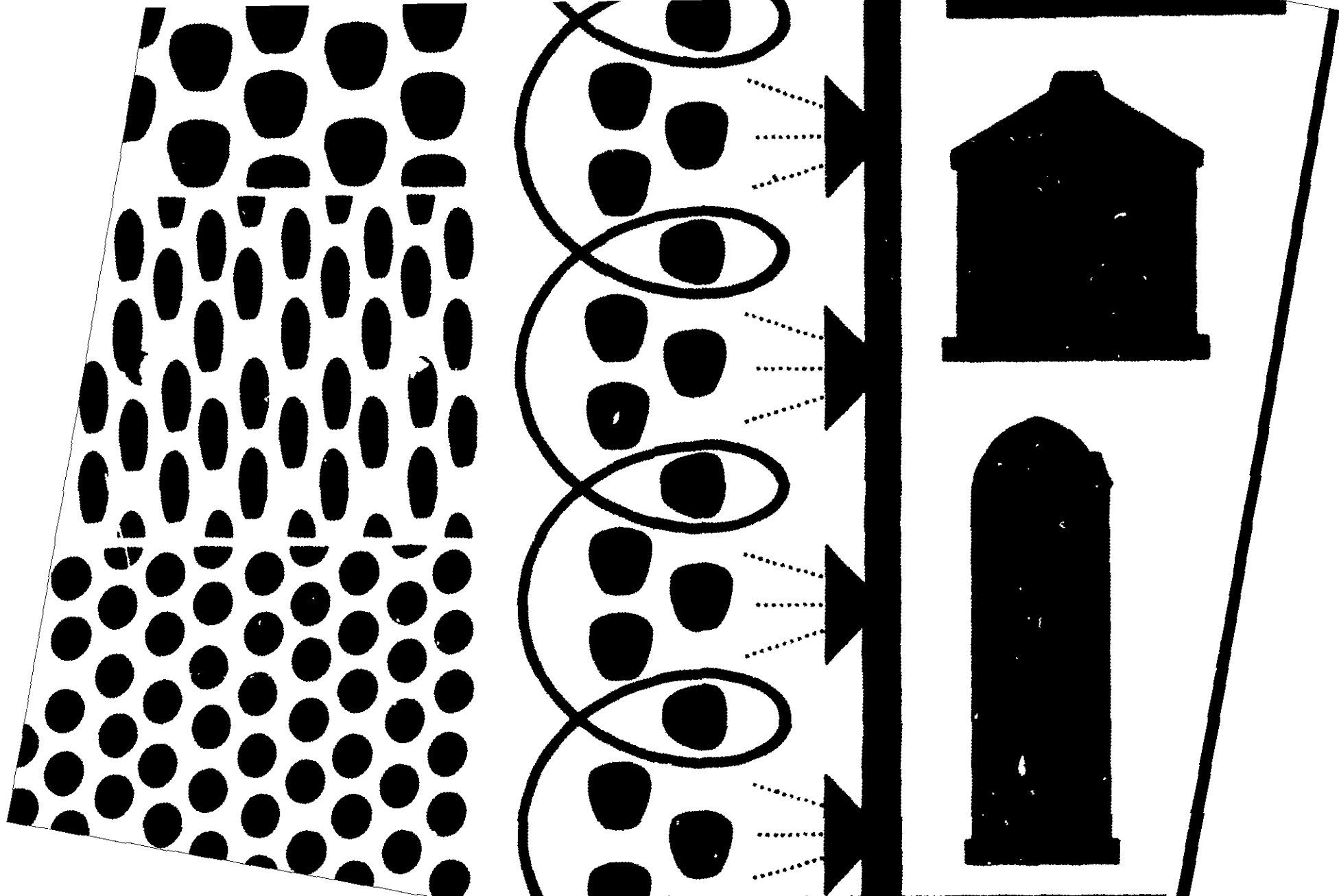

Technical Bulletin

USE IN FORAGE PRESERVATION

INTRODUCTION

In this Technical Bulletin Supplement are those directions for use of ChemStor^R when used as a forage preservative.

FOR PRESERVATION OF FORAGE TO BE STORED IN BALES OR AS LOOSE HAY

Spray ChemStor^R completely over entire fresh forage prior to storage in a well ventilated barn or shed. The following application rates should be used:

15-20% moisture at 10 pounds ChemStor^R per ton of forage

20-25% moisture at 20 pounds ChemStor^R per ton of forage

25-30% moisture at 30 pounds ChemStor^R per ton of forage

FOR PRESERVATION OF FORAGE INTENDED TO BE STORED AS SILAGE OR HAYLAGE

Apply 20 lbs ChemStor^R preservative per ton of fresh forage by metering the preservative into the blower housing continuously as the forage is blown into upright silos, or by metering the preservative into the blower housing of the forage harvester if silage is to be stored compacted in bunkers or pits. Follow customary best practices for moisture levels and compaction of forages.

For peripheral protection of the top layers of spoilage which often spoil on exposure to the air, surface spray with ChemStor^R preservative at a rate of 0.25 lb per sq ft. of surface.

In either of the above applications the ChemStor^R preservative can be diluted by adding an equal volume of water, to improve coverage and make metering easier, but such dilution is not necessary for good results.

This Supplement is to be affixed inside the front cover of the ChemStor^R Technical Bulletin.

February, 1975.

4.5.15

ACCEPTED
AUG 19 1975
Under the Federal Insecticide,
Fungicide, and Rodenticide Act,
as amended, for the pesticide
registered under
EPA Reg. No. **148-1114**

CHEMSTOR[®]

PRESERVATIVE SYSTEM

SOF 18

TABLE OF CONTENTS

I. INTRODUCTION	5
II. FEEDING CHEMICALLY TREATED HM GRAIN	6
■ Ration Formulations	
III. TREATING GRAIN	7
■ ChemStor® System	
■ Procedure	
IV. APPLICATION RATES TO WHOLE AND GROUND HM GRAIN	9
V. STORING GRAIN	14
VI. SAFETY AND HANDLING	16

6:18

INTRODUCTION

ChemStor[®] preservative is a liquid fungicide developed for use on high moisture whole and ground feed corn, sorghum, wheat, oats and barley. It is a mild blend of organic acetic and propionic acids—which allows the farmer to store shelled corn and other high moisture cereal grains for animal feeds with or without drying or the use of air tight silos.

ChemStor[®] acts as a preservative by preventing the growth of molds and most bacteria in high moisture cereal grains during storage—and is effective for the storage and preservation of both whole and ground cereal grains for animal feeds only.

The purpose of this manual, is to provide a basic introduction to the general aspects of the preservation of high moisture cereal grains via the ChemStor[®] system. More comprehensive literature is available on such specific subjects as treatment of grain, storage, and comparative economics.

For further information on these and other subjects, contact your local ChemStor[®] dealer.

IMPORTANT FEEDING NOTE

In feeding high moisture grain, it is important to account for the additional moisture content when formulating rations for livestock!

For example 100 pounds of 14% moisture grain will weigh 116 pounds at a moisture content of 26%. (See chart below)

Thus a ration consisting of 800 pounds of corn at a theoretical 14% moisture level, 150 pounds of roughage, and 50 pounds of supplement (total 1,000 lbs) should be adjusted *upward* to 928 pounds corn (*actual* 26% moisture), with the roughage and supplement rations remaining at 150 and 50 pounds respectively (Adjusted new total weight: 1128 pounds).

When dairy rations are fed on a production basis, a similar adjustment for moisture should also be made, to prevent underfeeding.

WEIGHT MOISTURE CHART

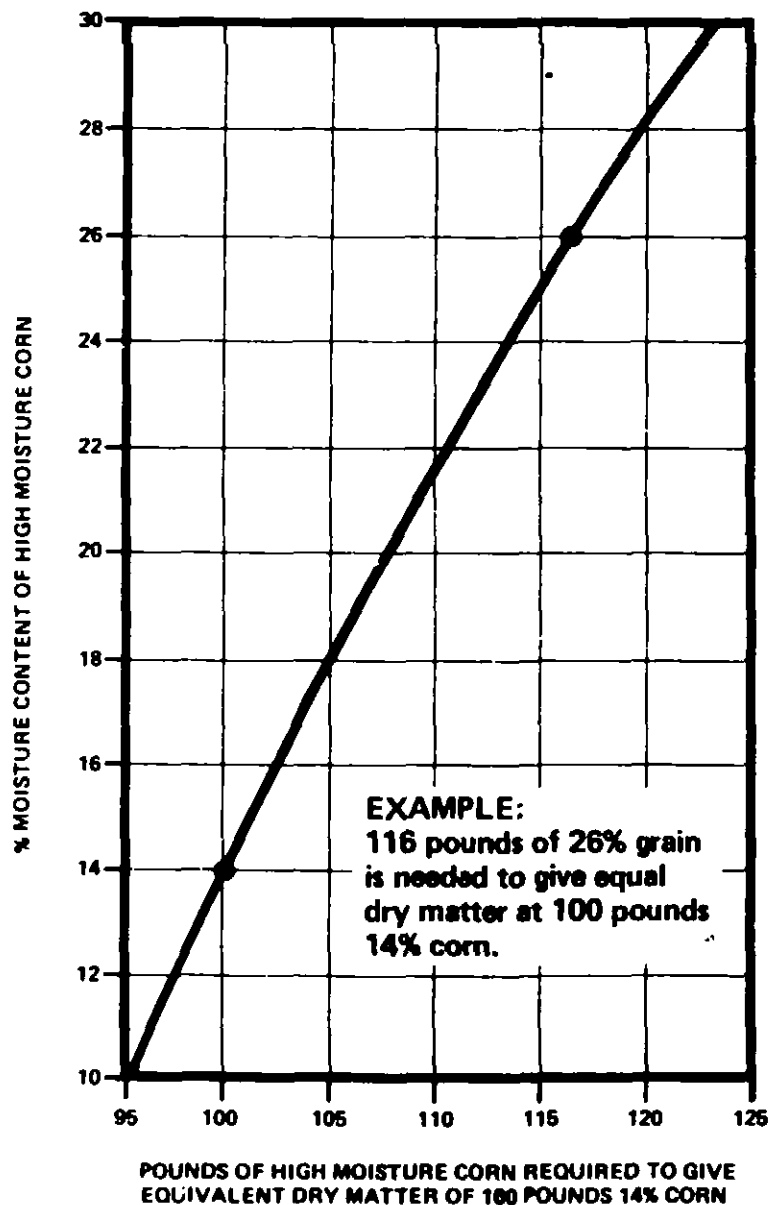

TREATING GRAIN WITH CHEMSTOR® PRESERVATIVE

Celanese has developed an exclusive application system for the treatment and handling of high moisture grain. It consists of the following components:

APPLICATOR

Applicators are available to treat approximately 400 to 1000 bushels per hour, at 25% moisture, and is made-up of the following: 1 Hopper, 2 Auger, 3 Spray Chamber, 4 Pump, 5 Control Panel, 6 Motor

The applicator weighs 450 pounds, has tires and can be maneuvered by one man

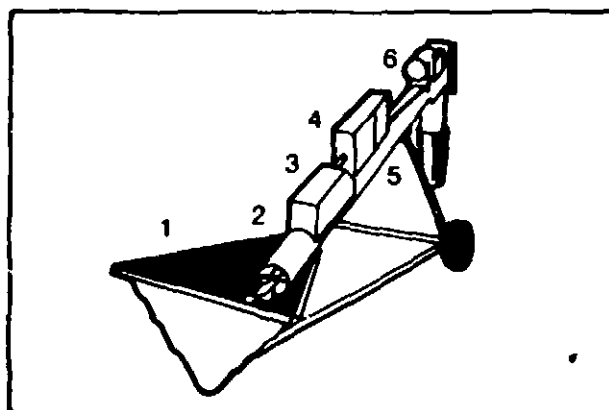

MOISTURE METER

The moisture meter is the key component, in determining the moisture level of the grain to be treated

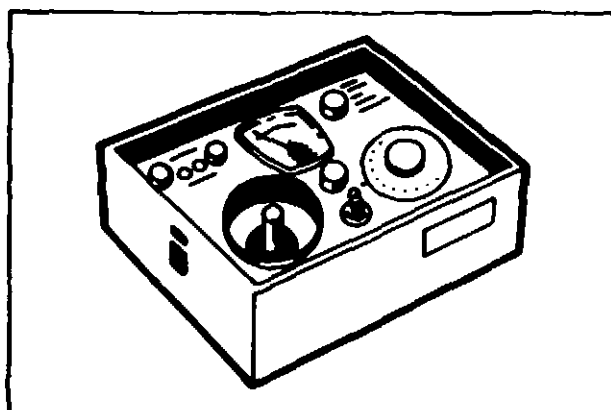

TEMPERATURE PROBE

The temperature probe is used to determine the temperature of grain during the storage period

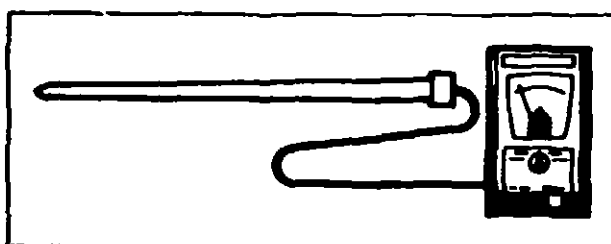

RELATED SAFETY EQUIPMENT

Goggles to protect the eyes and rubber gloves to protect the hands are essential for safe handling of ChemStor®

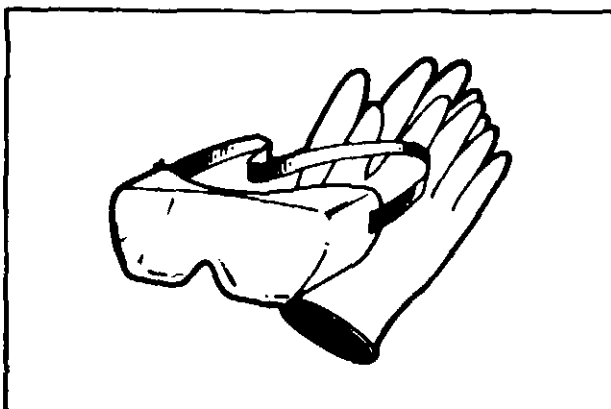

PROCEDURE

The treatment of the grain starts with the unloading of the grain into the polyethylene hopper of the ChemStor[®] Applicator

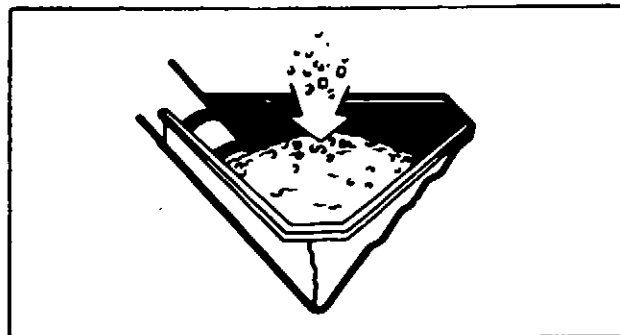

Next, the grain travels up the auger, at a pre-determined speed. (See operating manual)

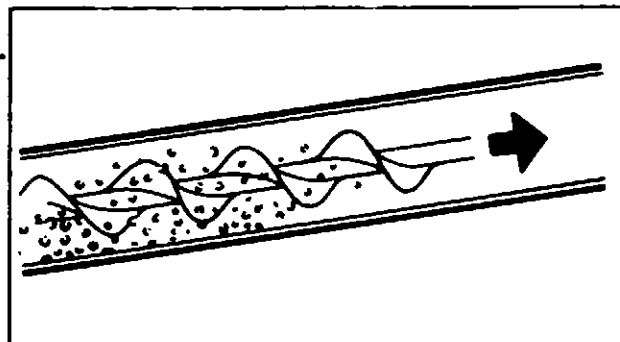

As the grain moves up the auger, it passes through the spray chamber, where the correct amount of ChemStor[®] preservative is applied automatically

Note: The applicator control panel has a shutdown valve that automatically stops the unit, should the supply of ChemStor[®] run out

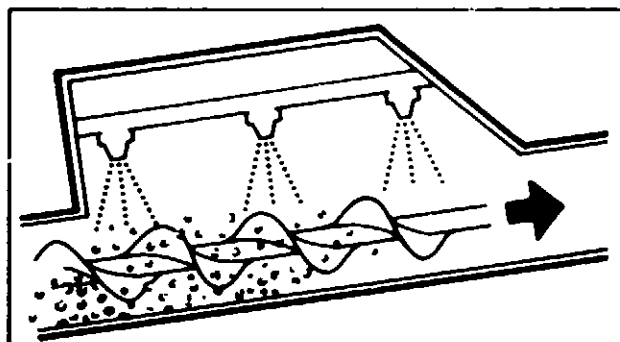

The combination of auger speed, the tumbling action of the auger, and the thoroughness of the three spray-heads, assures complete coverage of the grain to be treated

Once the grain has traveled through the applicator, it is delivered to the farmers conveyor, and on into storage. The crop is only handled once. No further treatment is necessary

100518

TYPICAL CHEMSTOR APPLICATION RATES

GRAIN MOISTURE ..	15	17	19	21	23	25	27	29
CHEMSTOR® WT %	0.60	0.70	0.85	0.95	1.10	1.20	1.33	1.45

TREATING GRAIN ABOVE THE 29% MOISTURE LEVEL IS GENERALLY NOT RECOMMENDED AS THE COST ADVANTAGES OF CHEMSTOR® BEGIN TO DIMINISH BEYOND THAT POINT

The three critical factors involved in properly treating any grain with ChemStor® are

- Moisture of grain being treated
- The amount of grain being treated, per unit of time

These two factors in turn, determine the third, which is

- Amount of ChemStor® to be applied

The following chart is an easy to use tool in determining the proper amount of ChemStor® to be used in treating grain

Directions:

First of all determine the moisture level of the harvested grain, with the Moisture Meter supplied with the system. Locate this percentage on one of the upward angled lines on the chart

Next, run a quantity of the grain to be weighed through the auger for ten (10) seconds, and collect it in a suitable container. Weigh this sample. Repeat the run a second time. Average the two results, and find this weight on the bottom horizontal scale on chart

By moving from this weight number straight up to where this imaginary line meets the angled line representing the moisture of the harvested grain and then left to the vertical scale—(Flowmeter Setting, Gallons per minute)—we arrive at the Flowmeter setting number which will apply the proper amount (flow-rate) of ChemStor®

Example:

Assume a grain harvested with a moisture content of 27% and its weight is 114 pounds per 10 second run through the auger

By locating the 114 pounds on the horizontal (bottom) scale following that line up to the 27% moisture line and then over to the vertical axis we find that the proper flow rate is 1.11 gals/min which is then set on the flowmeter. With this setting, you are ready to run your applicator and treat your grain

CHEMSTOR® APPLICATION RATE FROM 10 SECOND TIMED SAMPLE WEIGHT

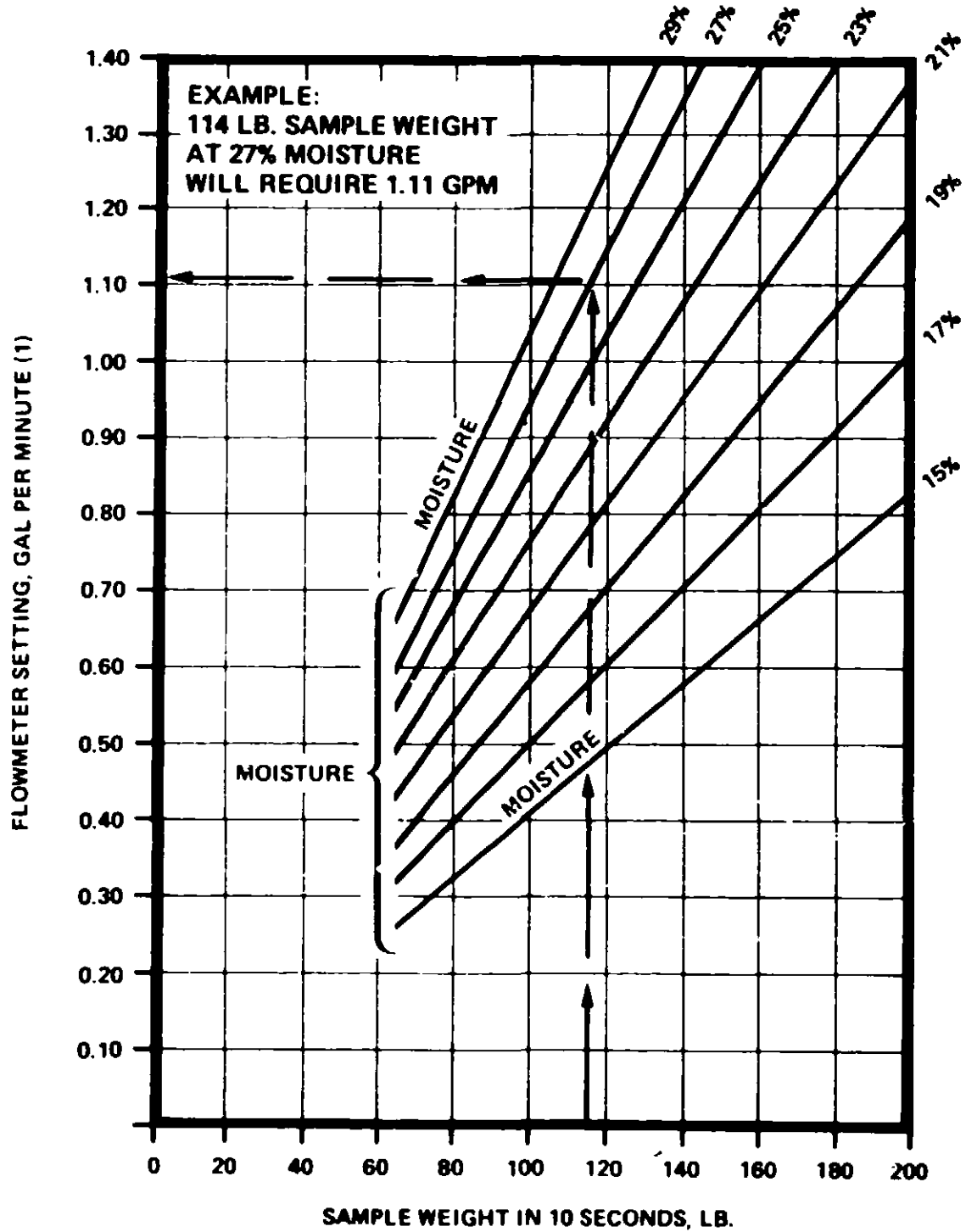

(1) Check flowmeter scale and multiply flow rate by 60 if scale reads gallons/hour.

120F 13

CHEMSTOR TREATMENT OF GROUND CORN COB AND KERNEL

Many farmers grind cob and kernel for feed to obtain the nutritional value available in the cob. Ground cob and kernel may be successfully treated with ChemStor[®] preservative if allowance is made for the moisture content of the cob. Mixtures of grain and cob will distort the moisture readings.

The following table and treatment curve have been constructed to provide a ready means of determining the percent of ChemStor[®] preservative required for treatment of ground cob and kernel.

Moisture Content of Kernels Only	Moisture of Cob Only	Moisture of Kernel and Cob Mixture
15.0%	17.5%	15.4%
20.0	32.5	22.5
25.0	44.0	29.0
30.0	52.0	35.1

The ChemStor[®] treatment level for ground cob and kernels is based on the moisture level of the mixture as calculated. The distribution of ChemStor[®] preservative must be uniform on both the cob and the kernels.

To determine the ChemStor[®] treatment level, hand shell several ears to obtain a representative sample of the grain. A moisture determination is made using the ChemStor[®] portable field moisture meter. Moisture of the kernel and cob mixture may then be read from the curve shown. Use grain only to obtain moisture readings. Once the moisture of the mixture is determined, proceed as outlined under treatment section.

CORN/COB CHOP CHEMSTOR® APPLICATION RATE

USE THIS CHART WHEN MOISTURE LEVEL OF CHOP MIXTURE IS MEASURED

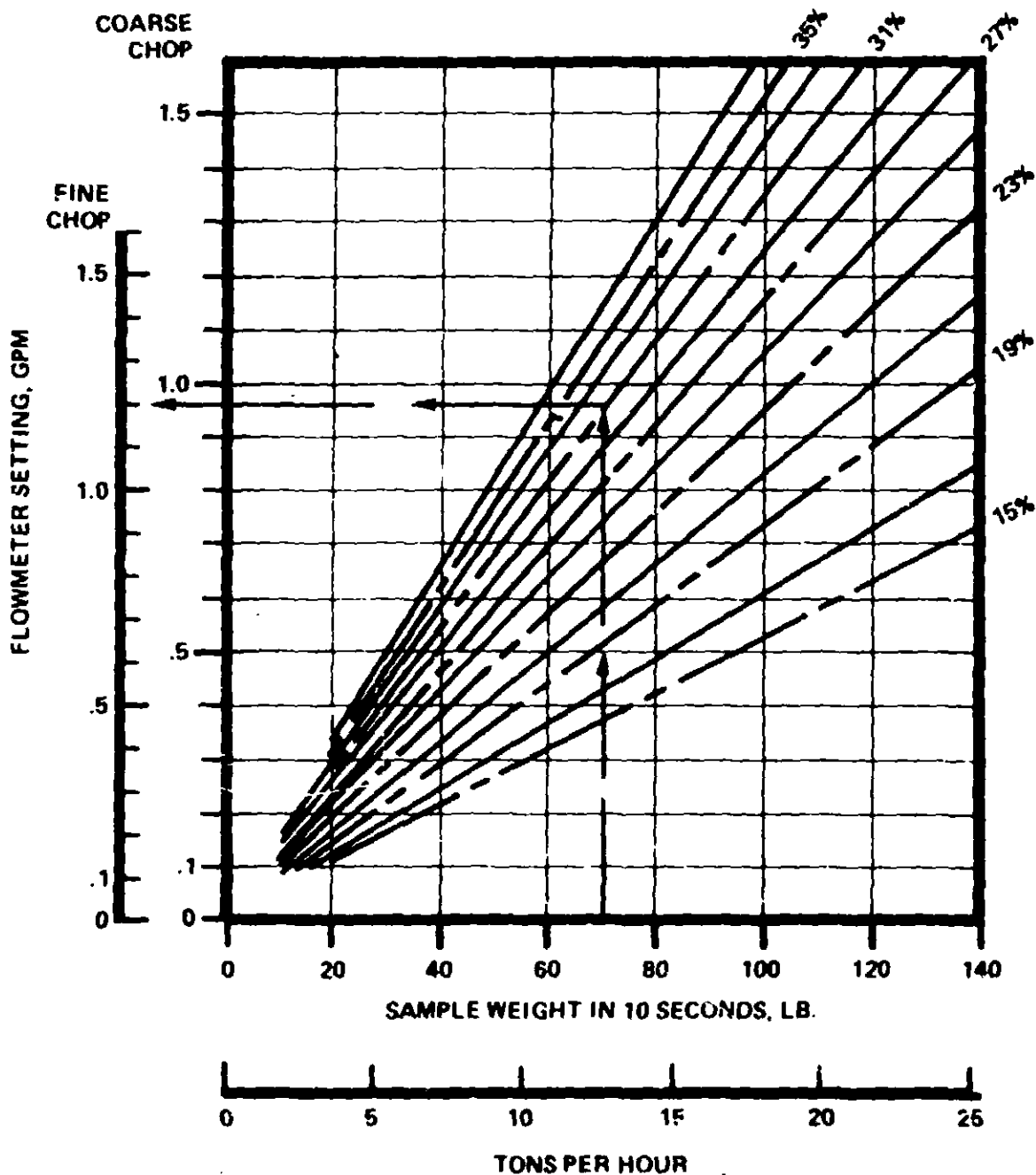

EXAMPLE: 70 LB SAMPLE WEIGHT IN 10 SECONDS,
31% MOISTURE MEASURED ON THE CHOP
MIXTURE. FOR FINE CHOP USE 1.2 GPM
FOR COARSE CHOP USE 0.9 GPM

1405/8

CORN/COB CHOP CHEMSTOR® APPLICATION RATE

USE THIS CHART WHEN MOISTURE LEVEL OF KERNEL GRAIN ONLY IS MEASURED

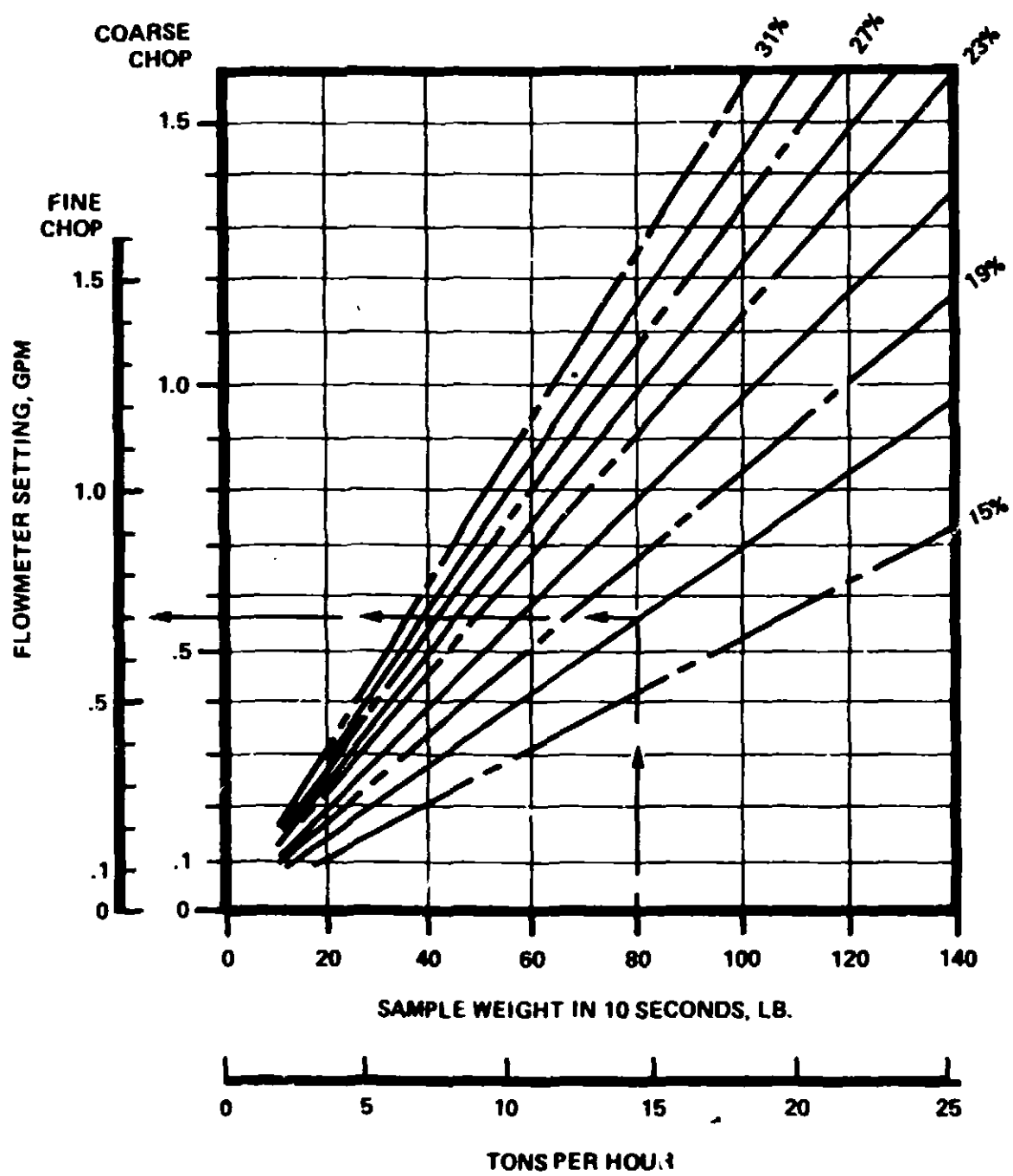

EXAMPLE: 80 LB SAMPLE WEIGHT IN 10 SECONDS,
17% MOISTURE MEASURED ON THE
KERNEL CORN ONLY. FOR FINE CHOP
USE .7 GPM; COARSE CHOP .6 GPM

15.18

STORING CHEMSTOR® PRESERVED GRAIN

Good harvesting and storage practices should always be followed in the handling, treatment, and storage of ChemStor® treated high moisture grain.

1. Clean storage area of dirt and old grain
2. Protect metal and concrete surfaces. ChemStor® preservative is a mixture of weak organic acids which will react with metal surfaces causing damage to the metal and sometimes causing the grain at the metal surface to mold. To a lesser extent it also reacts with a concrete surface.
3. Know your harvesting machinery and set it properly. Clean grain stores better.
4. Treat grain as soon as possible after harvesting—preferably within six hours. Mold growth often starts within a few hours after harvest.
5. Do not store ChemStor® treated grain with untreated dry grain, as this can lead to spoilage of untreated grain.
6. Level the surface of stored grain in bins to prevent moisture from condensing in the peaks. Leveled grain should not exceed eave height to allow sufficient ventilation space. Leave top surface of stored grain uncovered to prevent sweating.
7. Ventilate air space over bin or silo stored grain to prevent sweating by permitting moisture laden air to escape. If head space is large enough (for example, a small pile of grain inside a shed) natural ventilation should be adequate. Forced ventilation with fans is desirable in enclosed head spaces of bins, silos, covered piles of grain, or large volumes of grain in a shed. Size the fan to provide at least one air change every three minutes. Suction fans should have aluminum blades and a totally enclosed motor. Louvered sections in the roofs of bins, silos, and sheds will also aid in ventilating the head space. All ventilating systems should be designed to keep rain and snow from entering the storage container.
8. Use extra care, because experience has shown that high moisture grain stored at grain temperatures above 60° F is more difficult to preserve than grain stored below 60° F.

Early harvest in some areas will result in grain entering storage at higher temperatures

- a. Plan your feeding program to feed this grain first, and inspect the grain's temperature with the temperature probe more frequently.
- b. Avoid storing warm grains in volumes greater than 3000 bushels.
- c. Cooling, if properly performed, can give improved keeping qualities. Where warm grain (greater than 60°-70° F) in quantities greater than 1500 bushels is stored, cooling should be done as follows:
- d. Start fans only when overnight average temperature drops to 50° F.
- e. Once fans are started, run continuously until grain temperature reaches 55° F. Then shut off fan. Measure grain temperature near point where air leaves stored area.

NOTE: TO AVOID MOISTURE DEPOSITION ON GRAIN, AVOID OVER AERATING

DO NOT AERATE IN SPRING

9. Inspect grain weekly. Observe conditions of the surface and measure internal temperature. Notify your dealer immediately if you detect a problem.

CHEMSTOR® & STORAGE FACILITIES

- 1. Concrete Silos or Bins**—To prevent pitting of concrete or cement surfaces, a coating of Devco's No. 48201 Coal Tar Epoxy paint to the floor and lower portions of the wall is recommended. A drain in the bottom is also beneficial.
- 2. Galvanized or Steel Bins**—Both the acid treated grain and the vapors from the grain will react with the metal and damage the bin. Some protection is offered by covering the walls with 6-mil polyethylene. Areas exposed to vapors should be coated with coal tar epoxy.
- 3. Wooden Bins**—A highly recommended form of storage. Any exposed metal surfaces may be protected using coal tar epoxy paint.
- 4. Aluminum and Stainless Steel Bins**—Need no protection.
- 5. Buildings or Quonsets**—Protect metal walls in contact with grain as outlined above.
- 6. Pits and Trenches**—Ventilation of head space in pits and trenches is difficult if they are covered with polyethylene. A roof above the pit or trench is desirable as it keeps moisture out and allows proper ventilation. Polyethylene covers restrict air movement and cause moisture condensation. When grain is stored under polyethylene it may be necessary to remove the cover from time to time to ventilate, or to force ventilate by drawing air under the cover. All pits should be well drained.
- 7. Sheds**—Open sheds with dirt or concrete floors make good storage. Grain can be stored in piles, wooden bins, paper multiwall bins manufactured by St. Regis Paper Co., or snow fence enclosures under sheds. Snow fence should be lined with aluminum screen wire.
- 8. Temporary Storage**—Treated grain may be temporarily stored for 3 or 4 months in uncovered piles on the ground. Ground should be well drained.
- 9. Air-supported Structures**—Portable or permanent storage covers are available from a number of manufacturers. Many of the coated fabrics from which these covers are made are resistant to ChemStor® preservative and make excellent low-cost storage.

1705/1

SAFETY AND HANDLING

SAFETY

ChemStor[®] preservative is corrosive and causes eye damage and skin burns if improperly handled. Care should be taken to avoid inhaling the vapors, and of course, it should never be swallowed

Gloves, safety goggles or glasses and aprons should be worn at all times—whether handling the preservative, or grain that is still wet from treating. Protective gear should be made of rubber or equivalent impermeable material.

A water supply should be readily available in case of contact

FIRST AID

ChemStor[®] preservative will not cause discomfort immediately following contact—and thus does not give quick warning of possible burns. Therefore, speed is essential in removing any ChemStor[®] that has made contact with any unprotected areas. In case of exposure, the following first aid procedures should be followed:

SKIN SPLASH: Immediately flush all exposed areas that were splashed with large quantities of water for at least 15 minutes. A physician should be consulted in case of severe or extensive exposure

EYE CONTACT: Flush immediately with water for 15 minutes. Get medical attention

SWALLOWING: If ChemStor[®] is swallowed, *do not* attempt to induce vomiting. Wash out mouth with abundant quantities of water—then drink milk mixed with the whites of eggs. If milk and eggs are unavailable, drink as much water as possible. A physician should be called

CLOTHING: All contaminated clothing should be removed immediately and washed and cleaned separately and thoroughly before being used again

HANDLING

ELIMINATE ALL SOURCES OF HEAT AND OPEN FLAME FROM THE TREATING AREA AND STORAGE FACILITY.

Drums of ChemStor[®] preservative should be handled carefully to avoid undue stress. They should always be stored with the body plug upward.

When opening a drum, loosen the drum plug slightly (checking for internal pressure) and then proceed to open plug slowly to allow any internal pressure to vent. Pressure should never be used to discharge the contents of a drum. After the contents have been removed, drums should be washed and completely drained.

DO NOT ENTER STORAGE FACILITIES WITHOUT ADEQUATE VENTILATION!

DO NOT TREAT CORN OR OTHER CEREAL GRAINS WHICH MIGHT BE USED FOR SEED, MALTING PURPOSES, OR HUMAN CONSUMPTION!

TREATED CORN AND OTHER CEREAL GRAINS ARE TO BE USED FOR ANIMAL FEED ONLY!

Fish and wildlife cautions — DO NOT CONTAMINATE WATER BY DISPOSAL OF WASTE OR WATER USED IN CLEANING EQUIPMENT.

DRUMS NOT TO BE REUSED FOR ANY PRODUCT OTHER THAN CHEMSTOR[®]

GENERAL SAFETY POINTERS

Wear rubber soled shoes when treating with ChemStor[®] as spilled ChemStor[®] will be absorbed through leather soled shoes and then make contact with skin.

When the applicator is operating, keep hands away from the auger. Avoid wearing loose clothing.

Make sure the electrical system is properly grounded. When using 115 volt power, a 3-wire, grounded system is absolutely required.

When using 230 volt power, the usual 3-wire, grounded neutral system is adequate...but a separate ground wire, tied directly to the chassis is recommended.

WARRANTIES

Apart from the representations in this bulletin, there is NO WARRANTY, representation or condition of ANY KIND, expressed or implied (including NO WARRANTY OF MERCHANTABILITY) concerning material sold hereunder or containers in which shipped. Celanese Corporation shall have no responsibility, whether for breach or warranty, negligence, or otherwise, for any loss, damage or injury to persons or property arising out of the use, storage or handling of ChemStor[®] otherwise than in strict accordance with the directions contained in the ChemStor[®] Technical Bulletin.