

DENNEY-

KEYBURN



CHLORINE

Active Ingredient - Liquid Chlorine 100%

DANGER  **POISON**

**HAZARDOUS LIQUID AND
GAS UNDER PRESSURE
KEEP OUT OF REACH OF CHILDREN**

**DO NOT HANDLE OR USE UNTIL SAFETY PRE-
CAUTIONS RECOMMENDED BY MANUFACTURER
HAVE BEEN READ AND UNDERSTOOD.**

Do not breathe air containing this gas.

Do not get in eyes or on skin.

Do not heat cylinder.

Have available emergency gas masks approved by
U. S. Bureau of Mines for Chlorine Service.

In case of exposure, remove patient to fresh air,
keep warm and quiet, and call a physician.

Make daily inspection for leaks of all containers and
equipment containing chlorine whether in use or in
storage. Stop any leak since it will become greater
and can damage nearby equipment.

Write for copy of our Chlorine Bulletin and Wall Chart out-
lining recommended practice for handling chlorine containers.

MANUFACTURED FOR
DOREMUS CHEMICAL CO.
638 EAST 19th ST.
PATERSON, N. J. 07514

Net Wt.—2000 lbs.

EPA Reg. No. 33013-1

CYLINDER NUMBER	TARE WEIGHT

Handwritten signature

DENNEY-

KEYBURN



CHLORINE

Active Ingredient - Liquid Chlorine 100%

DANGER  **POISON**

**HAZARDOUS LIQUID AND
GAS UNDER PRESSURE
KEEP OUT OF REACH OF CHILDREN**

**DO NOT HANDLE OR USE UNTIL SAFETY PRE-
CAUTIONS RECOMMENDED BY MANUFACTURER
HAVE BEEN READ AND UNDERSTOOD.**

Do not breathe air containing this gas.

Do not get in eyes or on skin.

Do not heat cylinder.

Have available emergency gas masks approved by
U. S. Bureau of Mines for Chlorine Service.

In case of exposure, remove patient to fresh air,
keep warm and quiet, and call a physician.

Make daily inspection for leaks of all containers and
equipment containing chlorine whether in use or in
storage. Stop any leak since it will become greater
and can damage nearby equipment.

Write for copy of our Chlorine Bulletin and Wall Chart out-
lining recommended practice for handling chlorine containers.

MANUFACTURED FOR
DOREMUS CHEMICAL CO.
638 EAST 19th ST.
PATERSON, N. J. 07514

Net Wt. 48⁴ Cyl.—150 lb.

36⁴ Cyl.—100 lb.

EPA Reg. No. 33013-1

CYLINDER NUMBER	TARE WEIGHT

DENNEY-

REYBURN

CHLORINE

Active Ingredient - Liquid Chlorine 100%

DANGER  **POISON**

HAZARDOUS LIQUID AND
GAS UNDER PRESSURE
KEEP OUT OF REACH OF CHILDREN

**DO NOT HANDLE OR USE UNTIL SAFETY PRE-
CAUTIONS RECOMMENDED BY MANUFACTURER
HAVE BEEN READ AND UNDERSTOOD.**

Do not breathe air containing this gas.

Do not get in eyes or on skin.

Do not heat cylinder.

Have available emergency gas masks approved by
U. S. Bureau of Mines for Chlorine Service.

In case of exposure, remove patient to fresh air,
keep warm and quiet, and call a physician.

Make daily inspection for leaks of all containers and
equipment containing chlorine whether in use or in
storage. Stop any leak since it will become greater
and can damage nearby equipment.

Write for copy of our Chlorine Bulletin and Wall Chart out-
lining recommended practice for handling chlorine containers.

MANUFACTURED FOR
DOREMUS CHEMICAL CO.
638 EAST 19th ST.
PATERSON, N. J. 07514

Net Wt.—2000 lbs.

EPA Reg. No. 33013-1

CYLINDER NUMBER	TARE WEIGHT

CHLORINE

Active Ingredient - Liquid Chlorine 100%

DANGER  **POISON**

HAZARDOUS LIQUID AND
GAS UNDER PRESSURE
KEEP OUT OF REACH OF CHILDREN

**DO NOT HANDLE OR USE UNTIL SAFETY PRE-
CAUTIONS RECOMMENDED BY MANUFACTURER
HAVE BEEN READ AND UNDERSTOOD.**

Do not breathe air containing this gas.

Do not get in eyes or on skin.

Do not heat cylinder.

Have available emergency gas masks approved by
U. S. Bureau of Mines for Chlorine Service.

In case of exposure, remove patient to fresh air,
keep warm and quiet, and call a physician.

Make daily inspection for leaks of all containers and
equipment containing chlorine whether in use or in
storage. Stop any leak since it will become greater
and can damage nearby equipment.

Write for copy of our Chlorine Bulletin and Wall Chart out-
lining recommended practice for handling chlorine containers.

MANUFACTURED FOR
DOREMUS CHEMICAL CO.
638 EAST 19th ST.
PATERSON, N. J. 07514

Net Wt. 484 Cyl.—110 lb.

365 Cyl.—100 lb.

EPA Reg. No. 33013-1

CYLINDER NUMBER	TARE WEIGHT

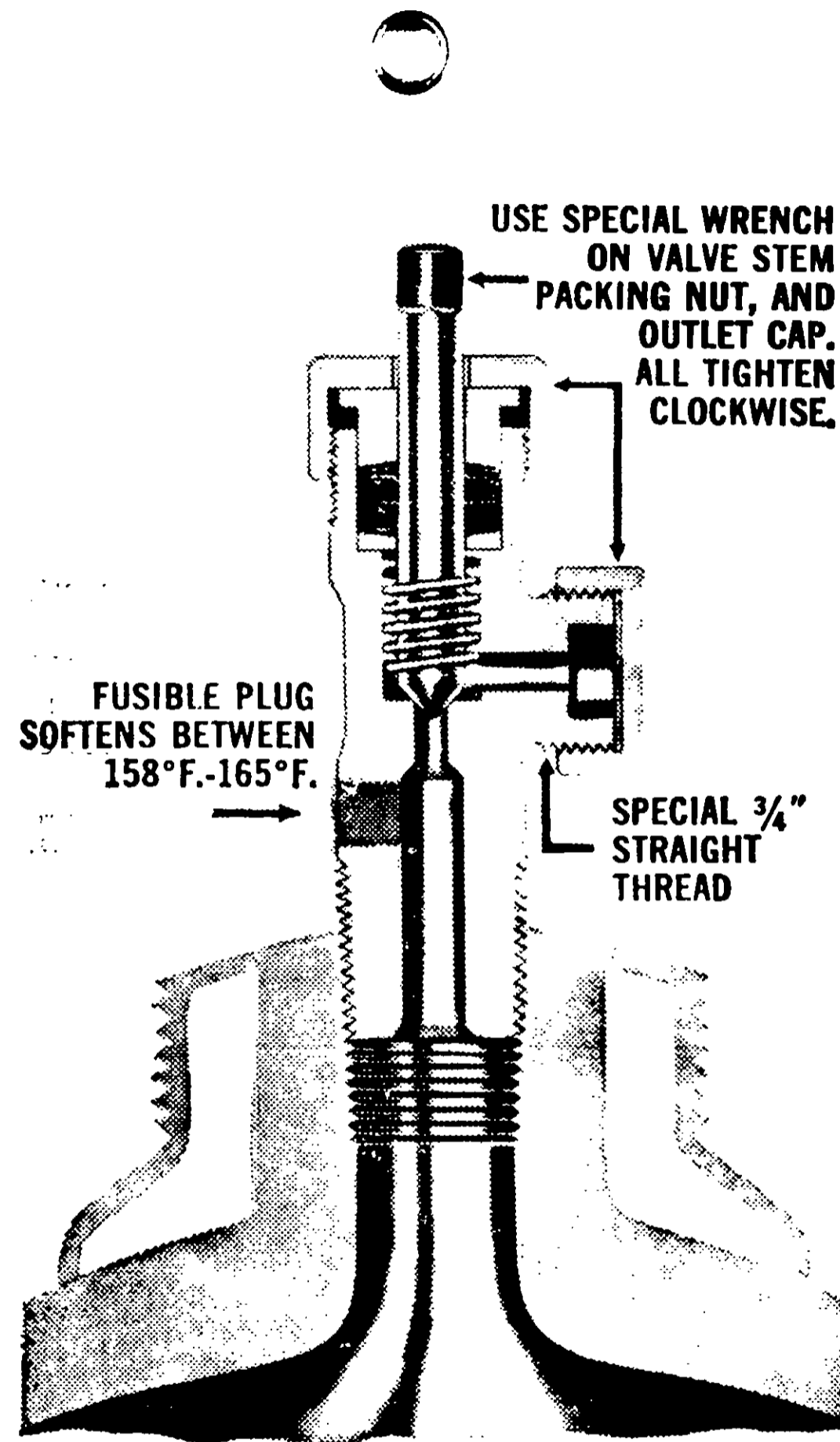

CROSS SECTION OF CYLINDER VALVE

Made in U.S.A. 2-3610-13 Printed in U.S.A.

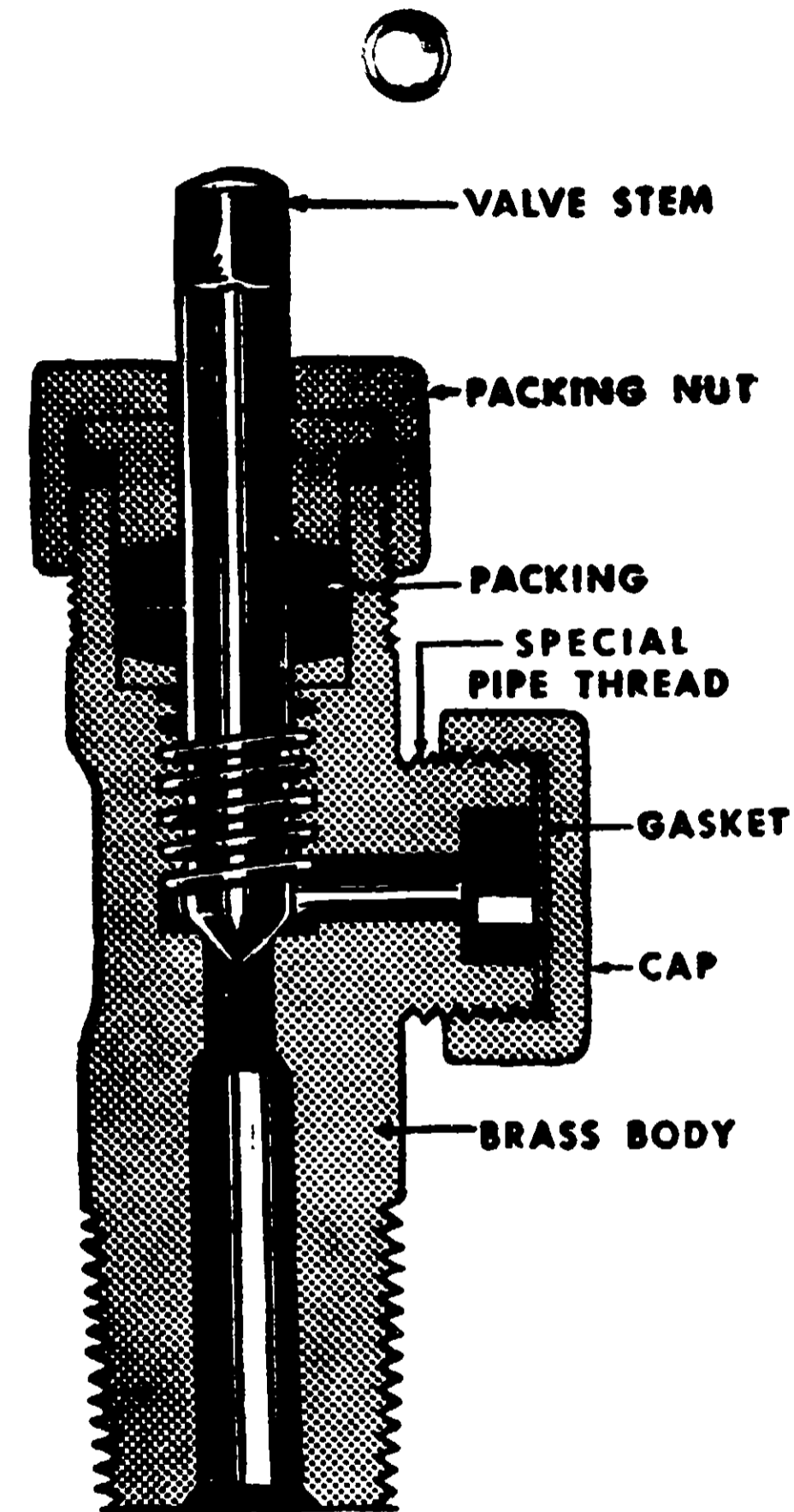

CROSS SECTION OF TON CONTAINER VALVE

Note: Do not tamper with fusible plugs at each end of the container. Fusible metal melts at 158° F. to 165° F.

Made In U.S.A. 2-3612-07 Printed in U.S.A.

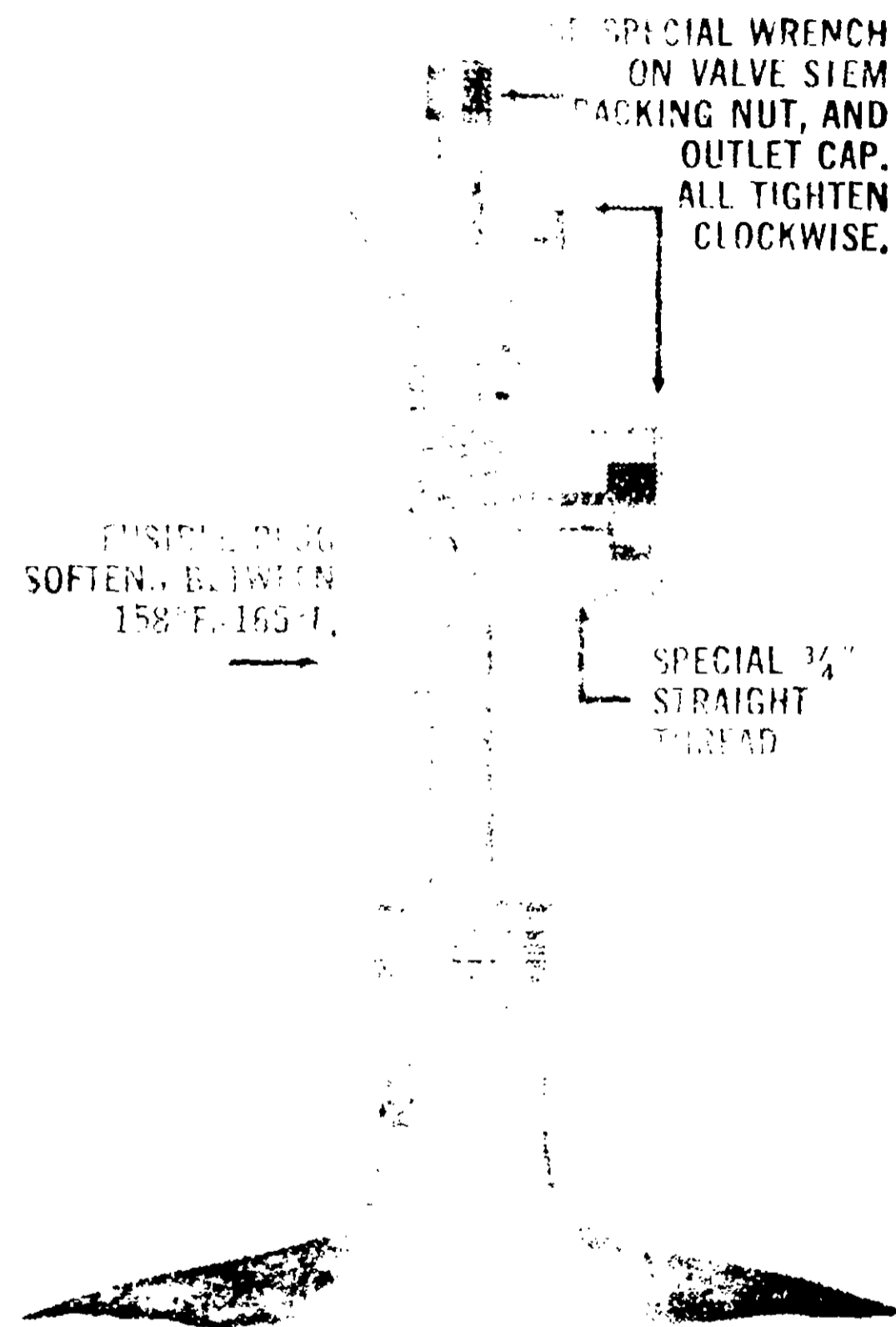

CROSS SECTION OF VALVE
Part 1 of 2

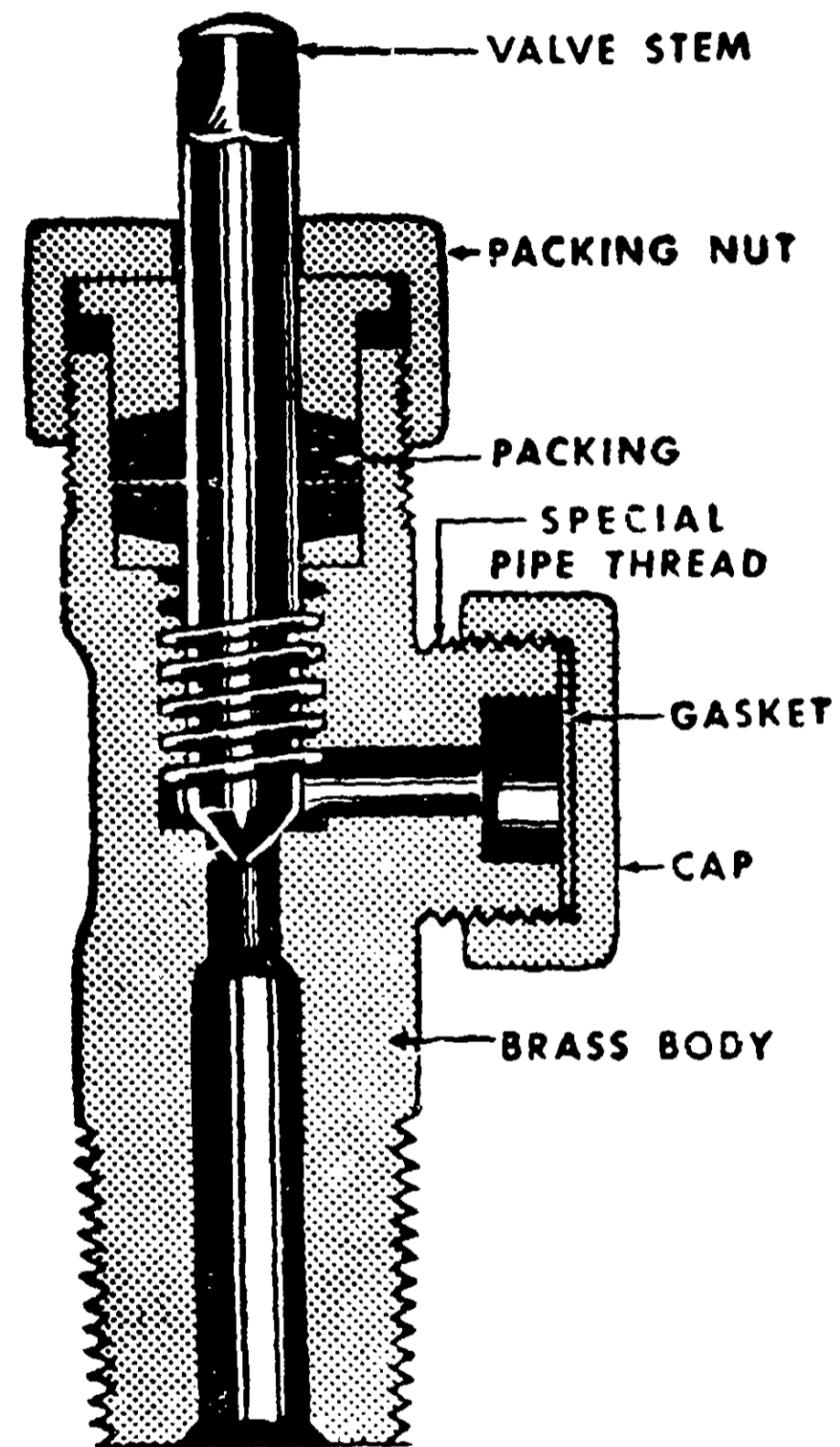

CROSS SECTION OF TON CONTAINER VALVE