

JUN 21 2006

UNITED STATES ENVIRONMENTAL PROTECTION AGENCY  
WASHINGTON, D.C. 20460United States  
Environmental Protection  
AgencyOffice of Pesticide ProgramsS. C. Johnson & Sons, Inc.  
1525 Howe Street  
Racine, WI 53403Attention: Mrs. Kelly K. Naujock  
Registration SpecialistSubject: **Raid 1000**  
EPA Registration No. 4822-531  
Notification Dated May 26, 2006

This will acknowledge receipt of your notification to add a non-pesticidal claim to the product label, submitted under the provisions of FIFRA Section 3(c)(9). Based on a review of the submitted material, the following comments apply.

The Notification is in compliance with PR Notice 98-10 and is acceptable. This information has been added to your file.

If you have any questions concerning this letter, please contact Martha Terry at (703) 308-6217.

Sincerely

A handwritten signature in black ink that reads "Martha S. Swindell".

Marshall Swindell  
Product Manager (33)  
Regulatory Management Branch 1  
Antimicrobials Division (7510P)

2 8 6

	United States <b>Environmental Protection Agency</b> Washington, DC 20460	<input type="checkbox"/> Registration <input type="checkbox"/> Amendment <input checked="" type="checkbox"/> Other	OPP Identifier Number
---	---	--	-----------------------

**Application for Pesticide - Section I**

1. Company/Product Number <b>4822-531</b>	2. EPA Product Manager <b>Mr. Swindell</b>	3. Proposed Classification <input checked="" type="checkbox"/> None <input type="checkbox"/> Restricted
4. Company/Product (Name) <b>S. C. Johnson / Raid 1000</b>	PM# <b>33</b>	
5. Name and Address of Application (Include ZIP Code) <b>S. C. Johnson &amp; Son, Inc.</b> <b>1525 Howe St.</b> <b>Racine, WI 53403</b> <input type="checkbox"/> Check if this is a new address		6. Expedited Review. In accordance with FIFRA Section 3(c)(3)(b)(i), my product is similar or identical in composition and labeling to:  EPA Reg. No.  Product Name

**Section II**

<input type="checkbox"/> Amendment – Explain below.  <input type="checkbox"/> Resubmission in response to Agency letter dated  <input checked="" type="checkbox"/> Notification – Explain below.	<input type="checkbox"/> Final printed labels in response to Agency letter dated <input type="checkbox"/> "Me Too" Application. <input type="checkbox"/> Other - Explain below.
--	---

**Explanation:** Use additional page(s) if necessary. (For Section I and Section II.) The purpose of this notification is to add a non-pesticidal claim to the product label. Under PRIA, a fee is not required for this submission as it is a notification.

**Section III**

<b>1. Material This Product Will Be Packaged In:</b>					
Child-Resistant Packaging <input type="checkbox"/> Yes * <input type="checkbox"/> No <i>*Certification must be submitted</i>	Unit Packaging <input type="checkbox"/> Yes <input type="checkbox"/> No If "Yes" Unit Packaging wgt.	No. Per container	Water Soluble Packaging <input type="checkbox"/> Yes <input type="checkbox"/> No If "Yes" Package wgt.	No. Per container	2. Type of Container <input type="checkbox"/> Metal <input type="checkbox"/> Plastic <input type="checkbox"/> Glass <input type="checkbox"/> Paper <input type="checkbox"/> Other (Specify)
3. Location of Net Contents Information <input type="checkbox"/> Label <input type="checkbox"/> Container		4. Size(s) Retail Container		5. Location of Label Directions <input type="checkbox"/> On Label <input type="checkbox"/> On Labeling accompanying product	
6. Manner in Which Label is Affixed to Product <input type="checkbox"/> Lithograph <input type="checkbox"/> Other <input type="checkbox"/> Paper glued <input type="checkbox"/> Stenciled					

**Section IV**

<b>1. Contact Point (Complete items directly below for identification of individual to be contacted, if necessary, to process this application)</b>		
Name <b>Mrs. Kelly K. Naujock</b>	Title <b>Registration Specialist</b>	Telephone No. (Include Area Code) <b>(262) 260-2686</b>

**Certification**

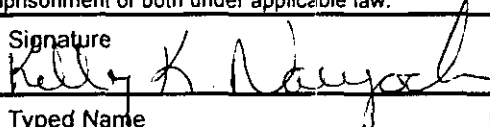
I certify that the statements I have made on this form and all attachments thereto are true, accurate and complete. I acknowledge that any knowingly false or misleading statements may be punishable by fine or imprisonment or both under applicable law.		6. Date Application Received <b>(Stamped)</b>
2. Signature 	3. Title <b>Registration Specialist</b>	
4. Typed Name <b>Mrs. Kelly K. Naujock</b>	5. Date <b>May 26, 2006</b>	

376

**SC Johnson**

A FAMILY COMPANY

S. C. Johnson & Son, Inc.  
1525 Howe Street  
Racine, WI 53403-2236  
262.260.2000

May 26, 2006

Mr. Marshall Swindell  
Product Manager #33  
Doc Processing Desk (Notif)  
Office of Pesticide Programs (7504P)  
U.S. Environmental Protection Agency  
1200 Pennsylvania Avenue, N.W.  
Washington, DC 20460

Subject: Notification  
Raid 1000  
EPA Reg. No. 4822-531

Dear Mr. Swindell:

On behalf of S.C. Johnson and Son, Inc., I am submitting a notification for the above referenced product. We have placed the non-pesticidal claim, "Over 70 Sprays!" on the product labeling. I have included a registration application marked as a notification, as well as 6 copies of the final, printed labeling.

As this action constitutes a notification, PRIA fees do not apply.

Thank you for your assistance with this matter. If I can be of any service, please don't hesitate to contact me at (262) 260-2686.

Sincerely,

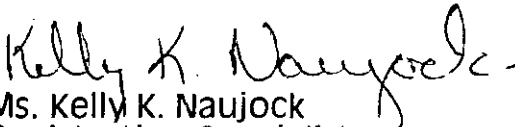
  
Ms. Kelly K. Naujock  
Registration Specialist

4 8 6

Over  
**70**  
SPRAYERS

# Owst<sup>®</sup> Mini Air Sanitizer

Eliminates  
Odors  
by killing  
odor-  
causing  
bacteria  
in the air

ACTIVE INGREDIENT:  
Triethylene Glycol... 6.0%  
INERT INGREDIENTS: 94.0%  
TOTAL: ..... 100.0%

**KEEP OUT OF  
REACH OF  
CHILDREN  
CAUTION**

SEE BACK PANEL  
FOR ADDITIONAL  
PRECAUTIONARY  
STATEMENTS

NET WT.  
.32 OZ. (9g)

**SC Johnson**  
A FAMILY COMPANY

517835

**DIRECTIONS FOR USE:**

It is a violation of the Federal law to use this product in a manner inconsistent with its labeling.

**TO TEMPORARILY REDUCE AIRBORNE BACTERIA** and eliminate odors in the air around the toilet, close all doors, windows and air vents. For maximum effectiveness relative humidity should be between 45% and 70%. Resume normal room ventilation after spray has settled.

1. Push the button to release the Oust® Mini Air Sanitizer 2 times for a room size of 4 1/2' x 4' x 7'.
2. Important: For maximum effectiveness and to kill odor-causing bacteria in the air, use only Oust® Mini Air Sanitizer canister in this unit.

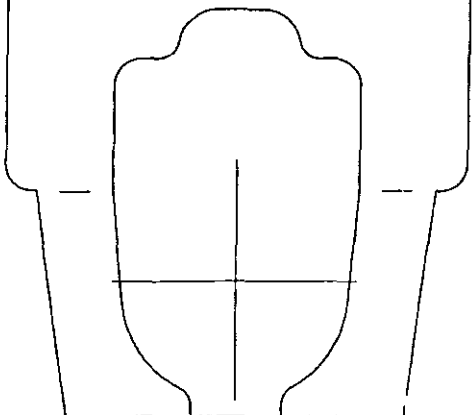

SC Johnson, Inc. will not be responsible for damage, injury, or poor performance caused by any other canisters other than the Oust® Mini Air Sanitizer canisters.

**STORAGE AND DISPOSAL STATEMENTS:**

**STORAGE:** Store away from heat, sparks and open flame, in an area inaccessible to children. **DISPOSAL:** This container may be recycled in the few, but growing number of communities where aerosol can recycling is available. Before offering for recycling, empty the can by using the product according to the label. (DO NOT PUNCTURE!) If recycling is not available, wrap the container and discard in trash.

**FIRST AID:**

- **If in eyes:** Hold eye open and rinse slowly and gently with water for 15-20 minutes. Remove contact lenses, if present, after the first 5 minutes, then continue rinsing eye. Call a poison control center or doctor for treatment advice.
- Have the product container or label with you when calling a poison control center or doctor, or going for treatment.

491635

**Oust® Mini**  
Air Sanitizer



New Oust® Mini Air Sanitizer helps reduce the number of airborne bacteria in any room to leave your home smelling clean and fresh. Unlike air fresheners that only mask odors temporarily, Oust® Mini Air Sanitizer eliminates tough odors such as bathroom, pet odors, and mildew.

90%

**For Position Only**  
Check Code Number Before  
Generating Actual Bar Code  
0 46500 14324 X

X XXXXX XXXXX X

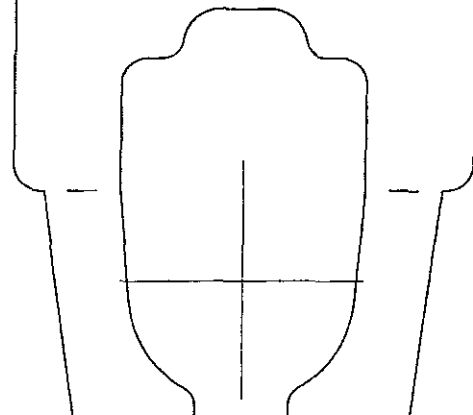

See insert for complete directions for use, first aid and storage and disposal.

**PRECAUTIONARY STATEMENTS  
HAZARDS TO HUMANS & DOMESTIC ANIMALS  
CAUTION:**

Avoid contact with food and food utensils. Avoid contact with eyes. Before using product throughout your home, use in one room and wait 24 hours to ensure that no one has any physical reactions to the product.

**Asthma and Allergy Sufferers:**

Consult your physician before using this product in your home.

**PHYSICAL/CHEMICAL HAZARDS: EXTREMELY FLAMMABLE!** Keep away from fire, sparks and heated surfaces. Contents under pressure. Do not puncture or incinerate container. Exposure to temperatures above 120°F may cause bursting.

EPA Reg. No. 4822-531 EPA Est. No. 4902 WI-1

S.C. Johnson & Son, Inc. Family Company  
Visit our web site at [www.oustodur.com](http://www.oustodur.com)

Questions? Comments?

Call 800-558-5952 or write Helen Johnson.

©2004 S.C. Johnson & Son, Inc., Johnson, WI 53403-2236 U.S.A.

All Rights Reserved. Canister Made in Thailand

# OWST<sup>®</sup> Mini Air Sanitizer



KEEP OUT OF REACH OF CHILDREN  
**CAUTION**

NET WT. 32 OZ. (9g)

Eliminates Odors by  
killing odor-causing  
bacteria in the air

**ACTIVE INGREDIENT:**

Triethylene Glycol.....6.0%

**INERT INGREDIENTS:** ...94.0%

**TOTAL:**.....100.0%

**KEEP OUT OF REACH OF  
CHILDREN. CAUTION:**

SEE OUTER PACKAGING FOR  
DIRECTIONS FOR USE AND  
ADDITIONAL PRECAUTIONARY  
STATEMENTS.

Questions? Comments?

Call 800-558-5252 or write Helen  
Johnson.

©2004 S.C. Johnson & Son, Inc.  
Racine, WI, 53403-2236 U.S.A.

All Rights Reserved.

EPA Reg. No. 4822-531

EPA Est. No. 4822-WI-1

Canister Made in Thailand

491649

989