

1839-178

10/24/2003

1/24

UNITED STATES ENVIRONMENTAL PROTECTION AGENCY

OCT 24 2003

Thomas W. Isaac  
Sr. Regulatory specialist  
Stepan Company  
22 W. Frontage Rd.  
Northfield, IL 60093

Subject: Solvent Free Disinfectant Wipes  
EPA Registration No. 1839-178  
Application Date: 8/1/03  
Receipt Date: 8/5/03

Dear Mr. Isaac:

The following amendment, submitted in connection with registration under the Federal Insecticide, Fungicide and Rodenticide Act (FIFRA), as amended, is acceptable:

Label Revisions

LABEL COMMENTS

1. Delete the claim "faster". This is a comparative claim and the Agency policy is not to allow comparative claims on pesticide labeling.
2. The alternate brand name "Household Disinfectant Wipes" is acceptable, however we have crossed it off the label, as the Agency doesn't stamp labels with alternate brand names.
3. Since it appears that your product as not tested in a soil load, the statements "scrubs and disinfects in one easy step" must be deleted from the label, as it is not supported by your data.

GENERAL COMMENTS

A stamped copy of the accepted labeling is enclosed. Submit three (3) copies of your final printed labeling before distributing or selling the product bearing the revised labeling.

CONCURRENCES							
SYMBOL	15100						
SURNAME	Jones						
DATE	10-29-03						

Should you have any questions or comments concerning this letter, please contact Zenobia Jones at (703) 308-6198.

Sincerely,

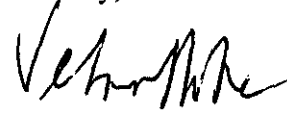

Velma Noble  
Product Manager 31  
Regulatory Management Branch 1  
Antimicrobial Branch (7510C)

# SOLVENT FREE DISINFECTANT WIPES



**LIMITED DISINFECTANT (This statement is mandatory.)**

*(Optional statements:)*

KILLS 99.9% OF SOME GRAM NEGATIVE BACTERIA (*Salmonella choleraesuis*, ATCC #10708, and *Escherichia coli*, ATCC #11229)  
CLEANER // NEW // QUICK // EASY // EFFECTIVE // FAST EFFECTIVE // CONVENIENT  
CLEANS, DISINFECTS & DEODORIZES  
ALL PURPOSE CLEANER  
KILLS 99.9% OF SOME BACTERIA (*Salmonella choleraesuis*, ATCC #10708 and *Escherichia coli*, ATCC #11229)  
ANTIBACTERIAL FORMULA CLEANS and DISINFECTS  
CITRUS SCENTED // FRESH SCENTED // LEMON SCENTED  
BLEACH-FREE // ALCOHOL-FREE // DISINFECT AND TOUCH-UP CLEAN ANYTIME

### ACTIVE INGREDIENTS

Octyl decyl dimethyl ammonium chloride .....	0.03990%
Dioctyl dimethyl ammonium chloride .....	0.01995%
Didecyl dimethyl ammonium chloride .....	0.01995%
Alkyl (50% C <sub>14</sub> , 40% C <sub>12</sub> , 10% C <sub>16</sub> ) dimethyl benzyl ammonium chloride .....	0.05320%
<b>INERT INGREDIENTS</b> .....	<b>99.86700%</b>
Total .....	100.00000%

**KEEP OUT OF REACH OF CHILDREN**

## CAUTION

See side panels for additional precautionary statements.

EPA REG. NO. 1839-178  
EPA EST. NO. 1839-IL-01

**STEPAN COMPANY**  
22 W. Frontage Rd.  
Northfield 60093

### NET CONTENTS:

X Pre-measured (Wipes) (Towelettes) (Cloths) (X) "x" (X)"  
(e.g. 40 Pre-measured Wipes (7" x 8") (11.7cm x 20cm))

ACCEPTED  
with COMMENTS  
EPA Letter Dated:

OCT 24 2003

Under the Federal Insecticide, Fungicide, and Rodenticide Act as amended, for the pesticide, registered under EPA Reg. No.

1839-178

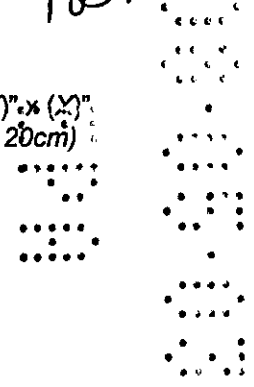

(Optional additional bullet points for label:)

4/24

- Scrubs and disinfects in one easy step.
- (Antibacterial) (Disinfecting) and scrubbing power all in one
- (All)(Multi) purpose
- (All)(Multi) surface
- Non-scratching
- The (wipe) (towelette) (cloth) that is (strong) (durable) (thick) (heavy) enough to scrub (and) (clean)
- (Textured cloth) gets up stubborn stuck on messes
- Will not scratch
- Cleans faster because the (scrubbies) (texture) remove(s) (stubborn) (stuck on) (dirt) (messes)
- Dual (action) (purpose)
- Scrubs like no other (wipe) (towelette) (cloth)
- Textured (wipe) (towelette) (cloth) (for tough jobs)
- Scrubbing (wipe) (towelette) (cloth)
- Wipes and scrubs
- The (wipe) (towelette) (cloth) that cleans (up (stubborn) (stuck-on) messes)
- Leaves a clean, fresh scent
- Leaves your (bathroom) (kitchen) fresh and clean
- Lint free
- Clean with just a wipe or a touch up
- Easy to use
- For (light touch ups) (quick clean-ups) (in one easy step)
- For household surfaces (all around the house)
- For when a regular (wipe) (towelette) (cloth) (just) can't get the job done
- Great for cleaning around the toilet
- Handles daily clean-ups with no need for additional sprays or buckets
- Heavy (light) duty jobs
- Just (pull) (pop), wipe and toss
- Makes (your job) (cleaning) (easier) (easy)
- No (mixing) (spraying) (mess) (and/or fuss)
- One step (clean) (cleaning)
- Quick easy clean-ups
- Saves time
- The smart (way to) clean (and disinfect)

ACCEPTED  
with COMMENTS  
EPA Letter Dated:  
OCT 24 2003  
Under the Federal Insecticide,  
Fungicide, and Rodenticide Act as  
amended, for the pesticide,  
registered under EPA Reg. No.  
1839-178

5/24

### DIRECTIONS FOR USE

It is a violation of Federal Law to use this product in a manner inconsistent with its labeling.

**(POTENTIAL LABEL CLAIMS:)**

<i>(Select any one of the following)</i>	<i>Followed by: (Select any one or more of the following)</i>	<i>May be followed by: (Select any one or more of the following)</i>
Kill(s)	<i>Salmonella choleraesuis (Salmonella), ATCC #10708</i>	Found on hard, non-porous Kitchen and Bathroom surfaces
Clean(s)	<i>Escherichia coli (E. coli), ATCC #11229</i>	From hard, non-porous Kitchen surfaces
Remove(s)	Household Kitchen/Bathroom Bacteria*	From hard, non-porous Bathroom surfaces
Effective Against	99.9% of some bacteria*	From hard, non-porous restroom surfaces
Wipes Away	Household bacteria*	<i>(one or more of the following surfaces):</i> kitchen counters, stovetops, sinks, the outside of microwaves, refrigerators, and other similar appliances, walls, countertops, finished hardwood, cabinets, floors, toilets, diaper pails, trash cans, glazed tile, tubs, changing tables, sinks, chrome, shower walls, bathrooms, public restrooms, door knobs, faucets, telephone receivers and key pads, patio furniture, cribs, car interiors, computers, hand rails, wall switch plates, door frames, restrooms, urinals, desks, and dining room surfaces
Are thick pre-moistened antibacterial wipes that remove	99.9% of some Household/Kitchen/Bathroom Bacteria*	
Easily removes	Odor causing bacteria*	
Cleans streak-free and kills		

\* *Salmonella choleraesuis (Salmonella), ATCC #10708, and Escherichia coli (E. coli), ATCC #11229*

**CLEANING:** Wipe surface with (wipe) (towelette) (cloth), let air dry. No need to rinse. These (wipes) (towelettes) (cloths) will not harm most surfaces. Not recommended on unpainted wood or glass.

**DISINFECTING:** Kills *Salmonella choleraesuis*, ATCC #10708, and *E. coli*, ATCC #11229, on hard, non-porous surfaces. Wipe surface to be disinfected. Allow surface to remain wet for 10 minutes before use. Let surface dry. A rinse is required for surfaces in direct contact with food.

For heavily soiled surfaces, clean before following disinfecting instructions.

Not for personal cleansing.

This is not a baby wipe!

**ACCEPTED  
with COMMENTS  
EPA Letter Dated:**

**OCT 24 2003**

*Under the Federal Insecticide,  
Fungicide, and Rodenticide Act as  
amended, for the pesticide,  
registered under EPA Reg. No.  
1839-178*

Canister Directions (Use any of the following instructions - can also use with canister icon)

**TO OPEN:**

- Remove lid from canister.
- Lift flap in center of lid.
- Pull up corner of center (wipe) (towelette) (cloth), twist to a point and thread through dispenser hole in lid. **DO NOT PUSH FINGER THROUGH OPENING.**
- Replace lid. Pull out exposed (wipe) (towelette) (cloth) and snap off. The next (wipe) (towelette) (cloth) pops up automatically. Dispose of used (wipes) (towelettes) (cloths) in trash receptacle. Snap center flap down when finished to retain moisture.
- Do not flush.

**TO OPEN PACKAGE:** Flip open dispensing cap and remove lid by pulling upward. Thread center (wipe) (towelette) (cloth) corner through slits in lid center. **DO NOT PUSH FINGER THROUGH OPENING.** Replace lid. Dispense (wipes) (towelettes) (cloths) by pulling out at an angle. Snap flip lid down when finished, to retain moisture. Dispose of used (wipes) (towelettes) (cloths) in trash. Do not flush.

**TO OPEN PACKAGE:** Pop open dispensing tab and remove top by lifting upward. Pull up corner of center (wipe) (towelette) (cloth), twist to a point and thread through slits in top. **DO NOT PUSH FINGER THROUGH SLITS.** Replace top and pull (wipe) (towelette) (cloth) at slight angle. The next (wipe) (towelette) (cloth) pops up automatically. Snap tab closed to retain moisture. Do not flush.

**DISPENSER:** to start feed. Remove large cover and discard seal from container. From center of (wipe) (towelette) (cloth) roll, pull up (wipe) (towelette) (cloth) corner, twist into a point and thread it through the hole in the container cover. **DO NOT PUSH FINGER THROUGH HOLE.** Pull through about one inch. Replace cover. Pull out first (wipe) (towelette) (cloth) and snap off at a 90 degree angle. Remaining (wipes) (towelettes) (cloths) feed automatically ready for next use. When through using, keep small center cap closed to prevent moisture loss. Do not flush.

Refillable Package Instructions: (Use with product supplied in refillable packages)

**TO OPEN PACKAGE:** Flip open dispensing flap and remove lid by lifting upward. Place (pouch) (package) in (container) (tub). Open pouch by peeling back seal. Insert (wipe) (towelette) (cloth) through opening in lid. Replace lid. The next (wipe) (towelette) (cloth) pops up automatically. When finished, close lid flap to retain moisture.

Refill Package Instructions: (Use for refill package)

**TO OPEN PACKAGE:** Flip open dispensing flap and remove lid by lifting upward. Place refill in (container) (tub). Open in (container) (tub) by peeling back seal. Insert (wipe) (towelette) (cloth) through opening in lid. Replace lid. The next (wipe) (towelette) (cloth) pops up automatically. When finished, close lid to retain moisture.

Resealable Package Instructions: (Use for product supplied in resealable pouches/packages)

**TO OPEN PACKAGE:** Slowly peel back label. (Pull out) (Remove) (wipes) (towelettes) (cloths) as needed. To retain moisture, reseal (pouch) (package) by firmly pressing label back on the (pouch) (package).

ACCEPTED  
 with COMMENTS  
 EPA Letter Dated:  
 OCT 24 2003  
 Under the Federal Insecticide,  
 Fungicide, and Rodenticide Act as  
 amended, for the pesticide,  
 registered under EPA Reg. No.  
 1839-178

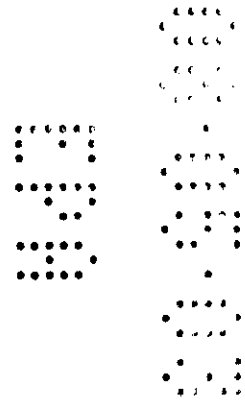

7124

**PRECAUTIONARY STATEMENTS**  
Hazards to Humans and Domestic Animals

**CAUTION:** Causes moderate eye irritation. Avoid contact with eyes or clothing. Wash thoroughly with soap and water after handling.

**FIRST AID**

Have the product container or label with you when calling a poison control center or doctor, or going for treatment.

**IF IN EYES:** Hold eyelids open and rinse slowly and gently with water for 15–20 minutes. Remove contact lenses if present, after the first 5 minutes, then continue rinsing the eye. Call a poison control center or doctor for treatment advice.

*(Optional)* You may contact XXX/XXX-XXXX for emergency medical treatment information.

**STORAGE AND DISPOSAL**

Do not contaminate water, food or feed by storage or disposal.

**PESTICIDE STORAGE:** Store in an area inaccessible to children.

**CONTAINER DISPOSAL:** Do not reuse empty (container) (canister). Rinse thoroughly before discarding in trash.

*(Optional for Product Supplied in Refillable Containers & Refill Package)*

**CONTAINER STORAGE/DISPOSAL:** Dispose of (wipe) (towelette) (cloth) in trash after use. Do not flush. Tightly close lid between uses to retain moisture. Do not reuse empty container except with refill, otherwise discard in trash.

*(Optional for Product Supplied in Resealable Packages)*

**CONTAINER STORAGE/DISPOSAL:** Dispose of (wipe) (towelette) (cloth) in trash after use. Do not flush. Reseal label between uses to retain moisture. Do not reuse empty (pouch) (package). Discard empty (pouch) (package) in trash.

**ACCEPTED**  
**With COMMENTS**  
**EPA Letter Dated:**  
OCT 24 2003  
Under the Federal Insecticide,  
Fungicide, and Rodenticide Act as  
amended for the pesticide,  
registered under EPA Reg. No.  
1839-178

8/24

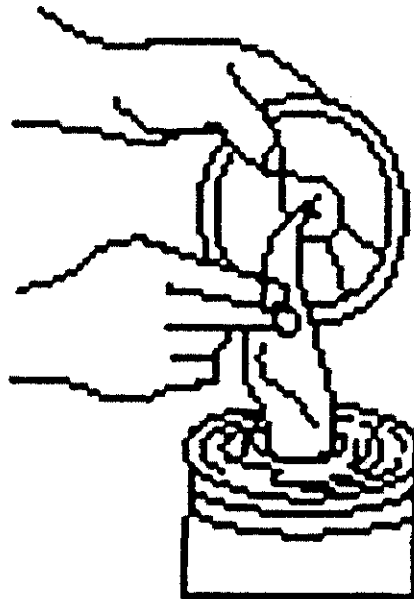

## Canister Directions

ACCEPTED  
with COMMENTS  
EPA Letter Dated:  
OCT 24 2003  
Under the Federal Insecticide,  
Fungicide, and Rodenticide Act, 28 USC  
amended, for the pesticide,  
registered under EPA Reg. No.  
1839-178



9/24

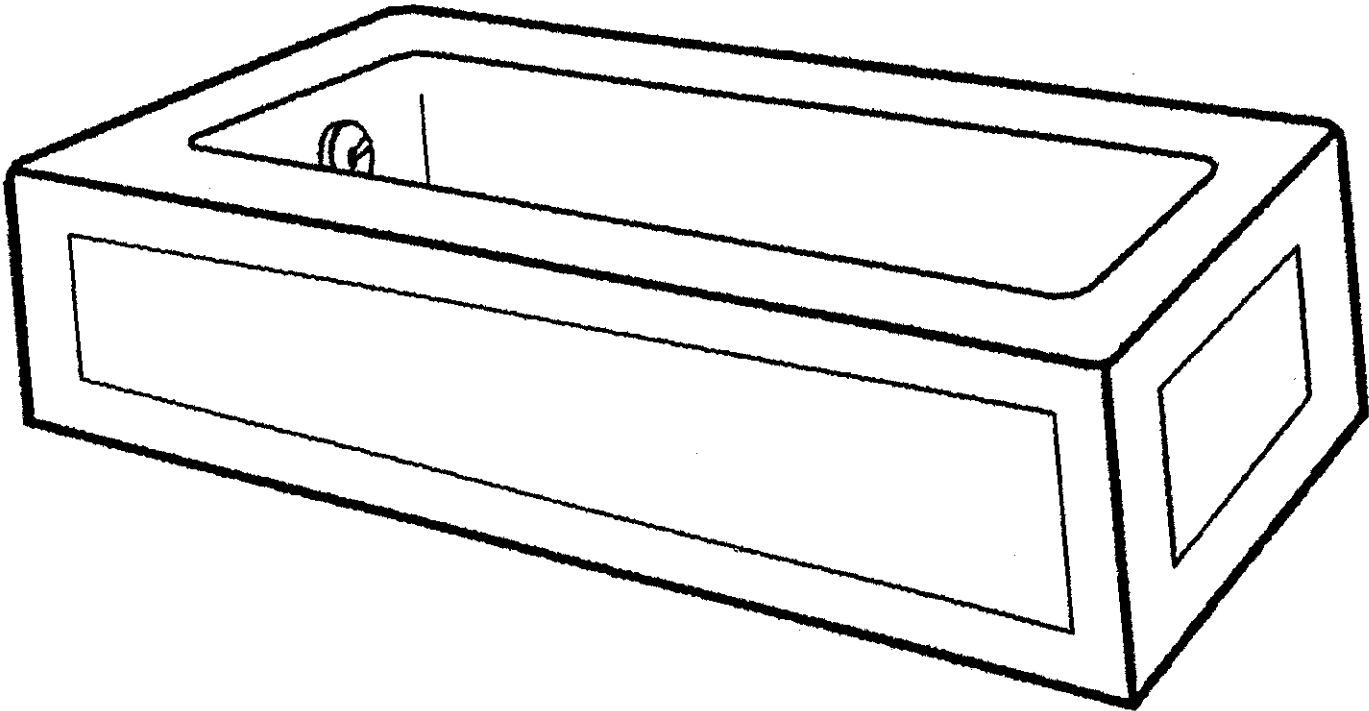

# Bathtub

ACCEPTED  
with COMMENTS  
EPA Letter Dated:  
OCT 24 2003

Under the Federal Insecticide,  
Fungicide, and Rodenticide Act as  
amended, for the pesticide,  
registered under EPA Reg. No.  
1839-178

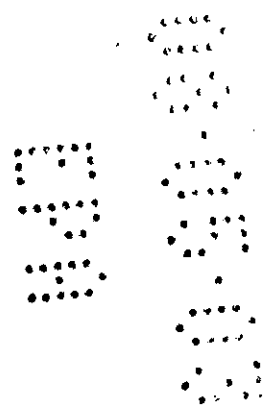

10/24

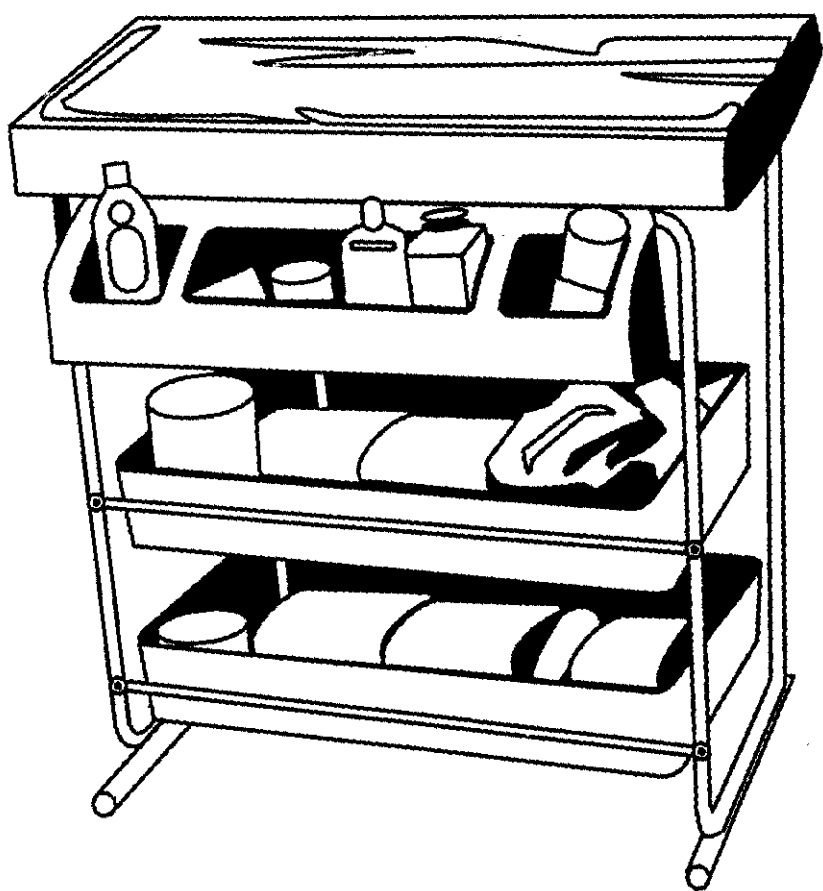

# Changing Table

ACCEPTED  
 with COMMENTS  
 EPA Letter Dated:  
 OCT 24 2003

Under the Federal Insecticide,  
 Fungicide, and Rodenticide Act as  
 amended, for the pesticide,  
 registered under EPA Reg. No.  
 1839-178

11/24



# Door Knob

ACCEPTED  
with COMMENTS  
EPA Letter Dated:

OCT 24 2003

Under the Federal Insecticide,  
Fungicide, and Rodenticide Act as  
amended; for the pesticide,  
registered under EPA Reg. No.

1839-178

12/24

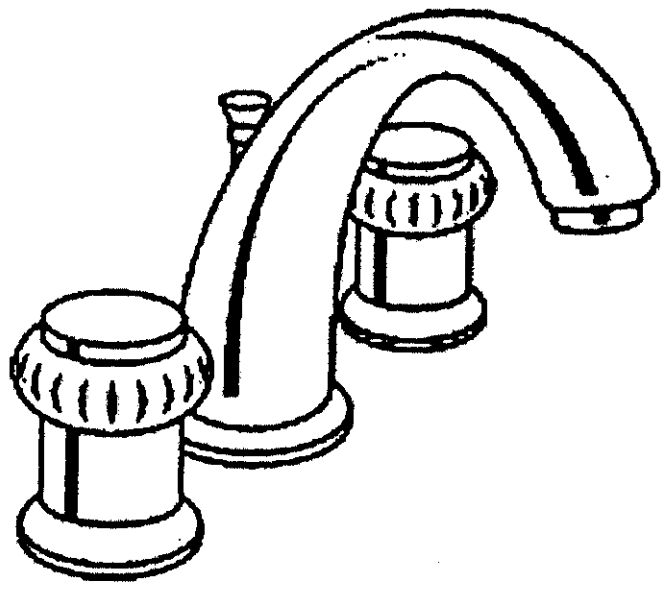

# Faucet

ACCEPTED  
with COMMENTS  
EPA Letter Dated:  
OCT 24 2003  
Under the Federal Insecticide,  
Fungicide, and Rodenticide Act as  
amended, for the pesticide,  
registered under EPA Reg. No.  
1839-178

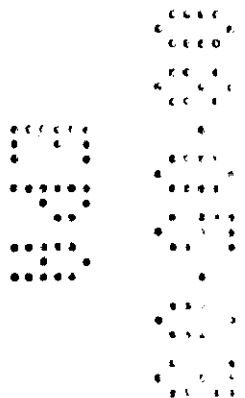

13/24-



# Kitchen Countertops

ACCEPTED  
with COMMENTS  
EPA Letter Dated  
OCT 24 2003

Under the Federal Insecticide,  
Fungicide, and Rodenticide Act,  
registered for the use of this  
product under EPA Reg. No.

Stepan Company  
Northfield, IL 60093  
EPA Reg. No. 1839-178

1839-178

page 11 of 22

Amend 08/01/03

14/24-

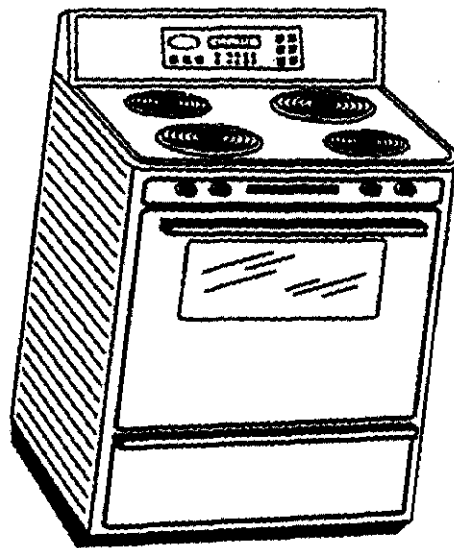

# Stovetop

ACCEPTED  
with COMMENTS  
EPA Letter Date:

OCT 24 2003

1839-178

Stepan Company  
Northfield, IL 60093  
EPA Reg. No. 1839-178

15/24

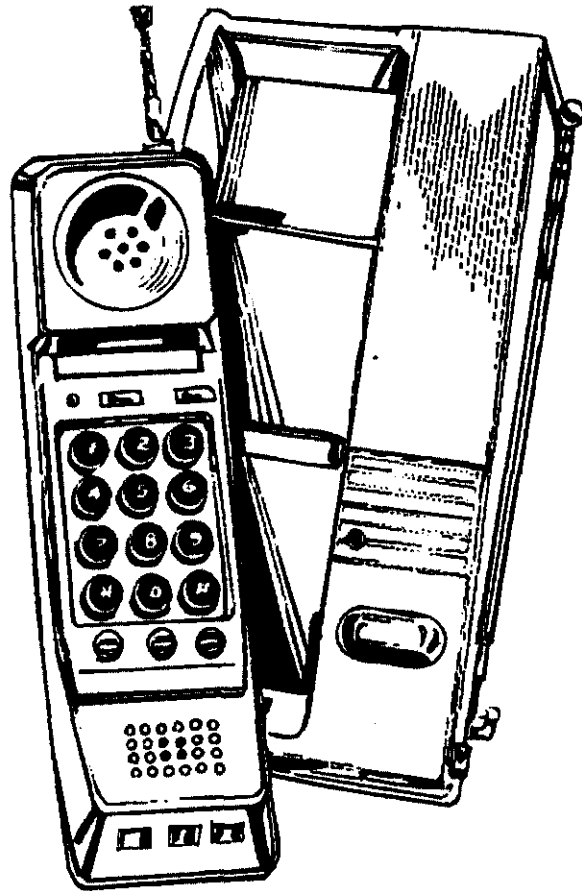

## Telephone Receivers and Key Pads

ACCEPTED  
with COMMENTS  
EPA Letter Dated:

OCT 24 2003

Under the Federal Insecticide,  
Fungicide, and Rodenticide Act as  
amended for the pesticide,  
registered under EPA Reg. No.

1839-178

page 13 of 22

Stepan Company  
Northfield, IL 60093  
EPA Reg. No. 1839-178

Amend 08/01/03

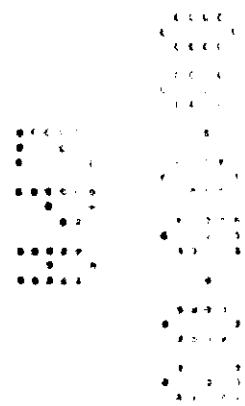

16/24

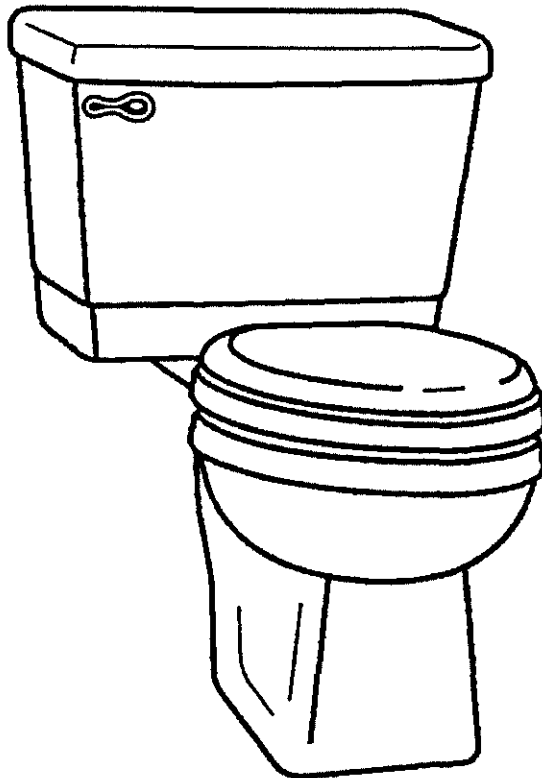

# Toilet

ACCEPTED  
with COMMENTS  
EPA Letter Dated:  
OCT 24 2003

Under the Federal Insecticide,  
Fungicide, and Rodenticide Act as  
amended, for the pesticide,  
registered under EPA Reg. No.

1839-178



17/24

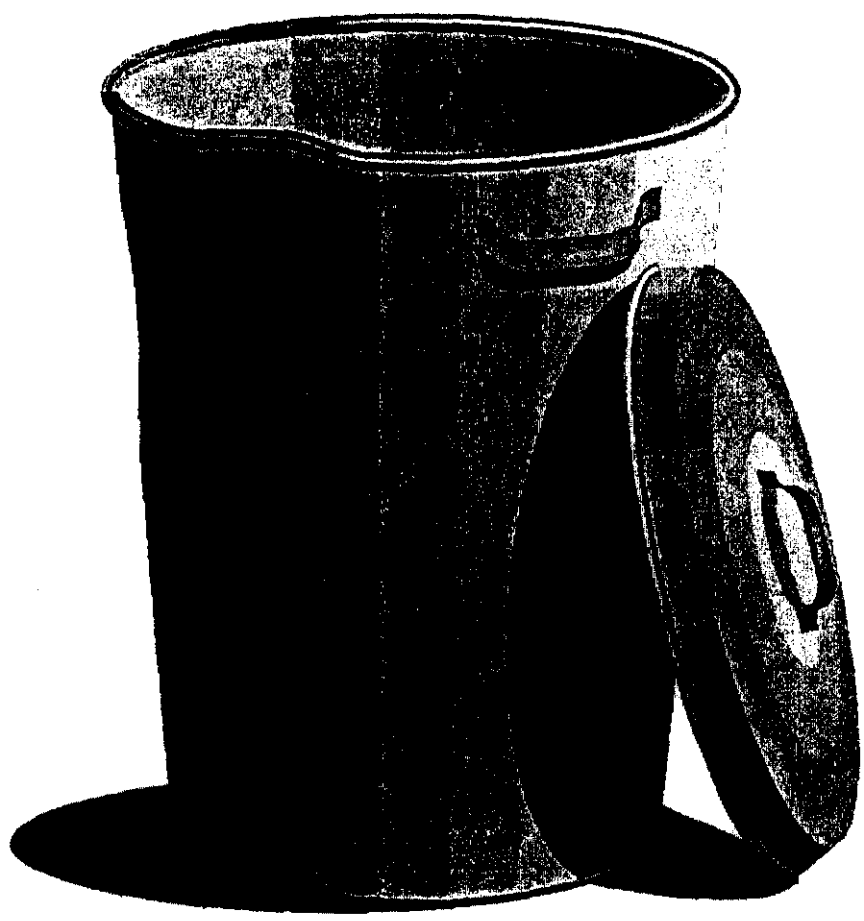

# Garbage Can

ACCEPTED  
with COMMENTS  
EPA Letter Dated:  
OCT 24 2003

Under the Federal Insecticide,  
Fungicide, and Rodenticide Act as  
amended, for the pesticide,  
registered under EPA Reg. No.

1839-178

Stepan Company  
Northfield, IL 60093  
EPA Reg. No. 1839-178

18/24

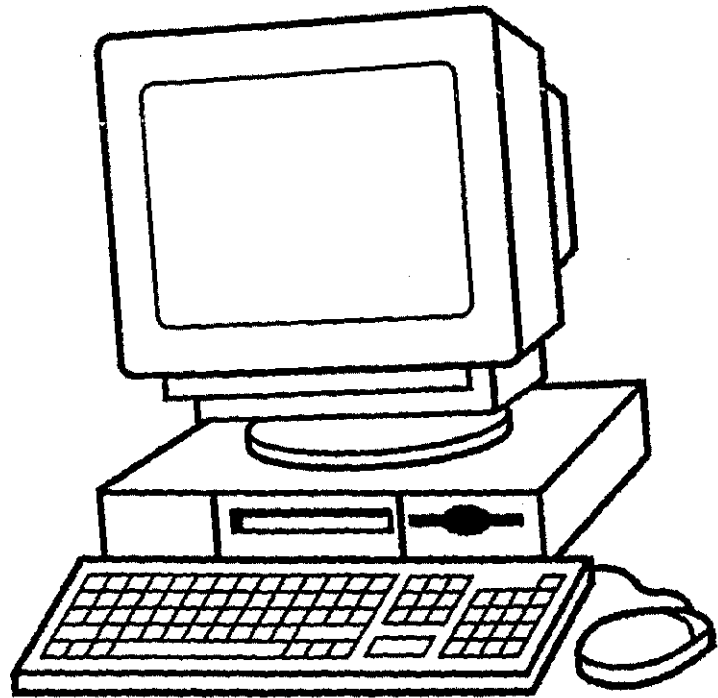

# Computer

ACCEPTED  
with COMMENTS  
EPA Letter Date:

OCT 24 2003  
Under the Federal Insecticide,  
Fungicide, and Fumigant Act as  
amended, for the pesticide  
registered under EPA Reg. No.  
1839-178

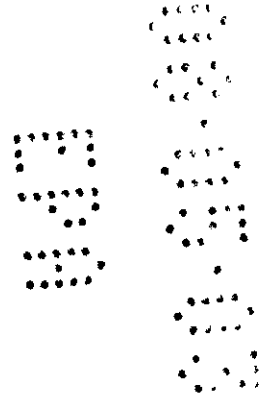

19/24



## Patio Furniture

ACCEPTED  
with COMMENTS  
EPA Letter Dated:  
OCT 24 2003

Under the Federal Insecticide,  
Fungicide, and Rodenticide Act as  
amended, for the pesticide  
registered under EPA Reg. No.

1839-178

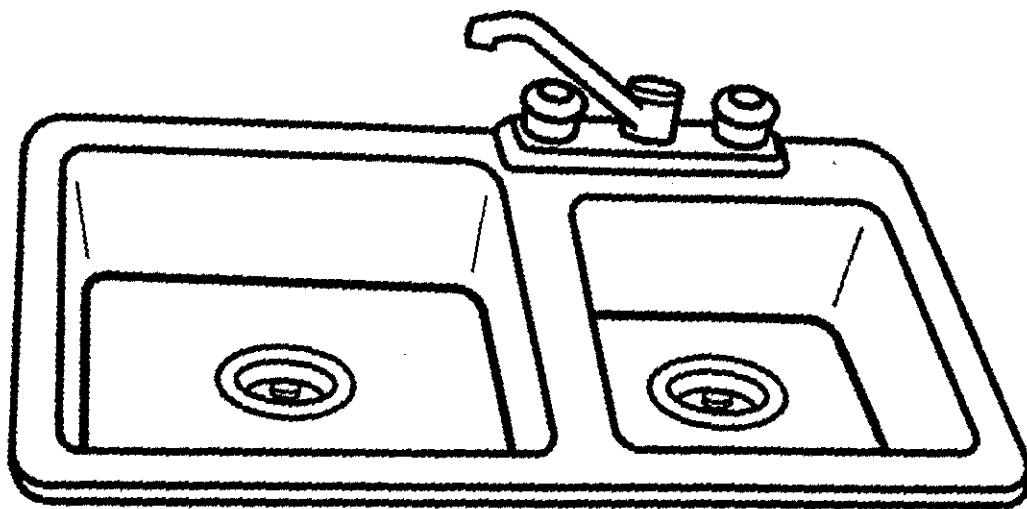

# Sinks

ACCEPTED  
with COMMENTS  
EPA Letter Dated:  
OCT 24 2003  
Under the Federal Insecticide,  
Fungicide, and Rodenticide Act as  
amended, for the pesticide,  
registered under EPA Reg. No.  
1839-178

Stepan Company  
Northfield, IL 60093  
EPA Reg. No. 1839-178

page 18 of 22

Under the Federal Insecticide,  
Fungicide, and Rodenticide Act as  
amended, for the pesticide,  
registered under EPA Reg. No.  
1839-178

Stepan Company  
Northfield, IL 60093  
EPA Reg. No. 1839-178

page 19 of 22

Northfield, IL 60093  
EPA Reg. No. 1839-178

page 21 of 22

Amend 08/01/03

Amend 08/01/03

Amend 08/01/03

2/24

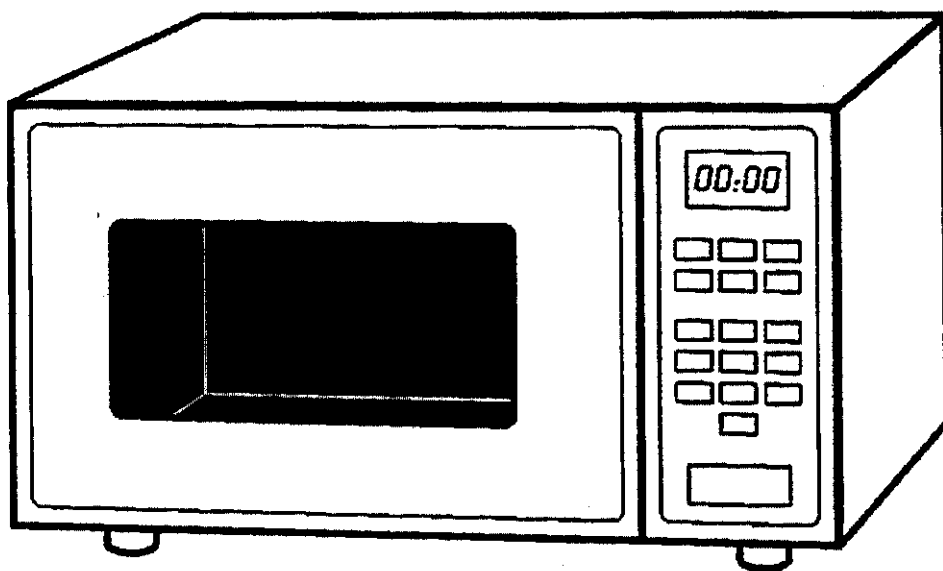

# Outside of microwaves

**ACCEPTED**  
with **COMMENTS**  
EPA Letter Dated:  
**OCT 24 2003**

Under the Federal Insecticide,  
Fungicide, and Rodenticide Act as  
amended, for the pesticide,  
registered under EPA Reg. No.

**1839-178**

Stepan Company  
Northfield, IL 60093  
EPA Reg. No. 1839-178

page 19 of 22

Amend 08/01/03

Fungicide, and Rodenticide Act as  
amended, for the pesticide,  
registered under EPA Reg. No.

**1839-178**

Stepan Company  
Northfield, IL 60093  
EPA Reg. No. 1839-178

page 20 of 22

Amend 08/01/03

28/24-

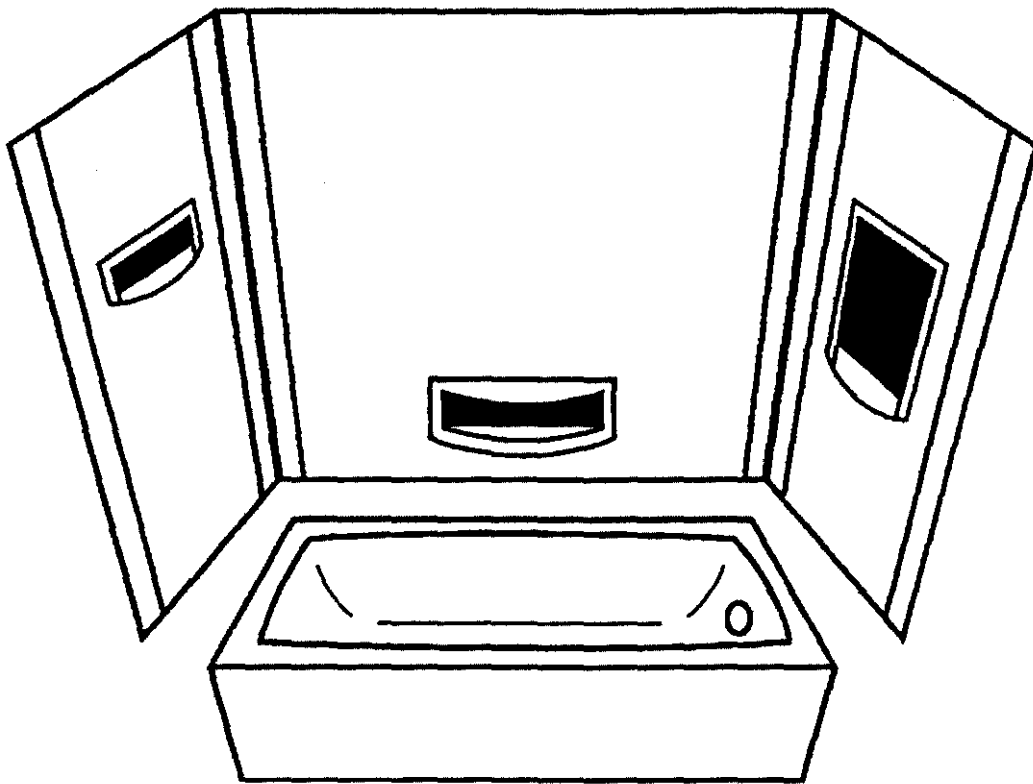

# Tub and Shower walls

ACCEPTED  
with COMMENTS  
EPA Letter Dated:  
OCT 24 2003

Under the Federal Insecticide,  
Fungicide, and Rodenticide Act as  
amended, for the pesticide,  
registered under EPA Reg. No.

1839-178

23/24



# Baby crib

**ACCEPTED**  
with **COMMENTS**  
EPA Letter Dated:  
OCT 24 2003

Under the Federal Insecticide,  
Fungicide, and Rodenticide Act as  
amended, for the pesticide,  
registered under EPA Reg. No.

1839-178

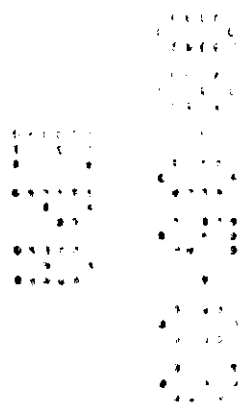

34/24

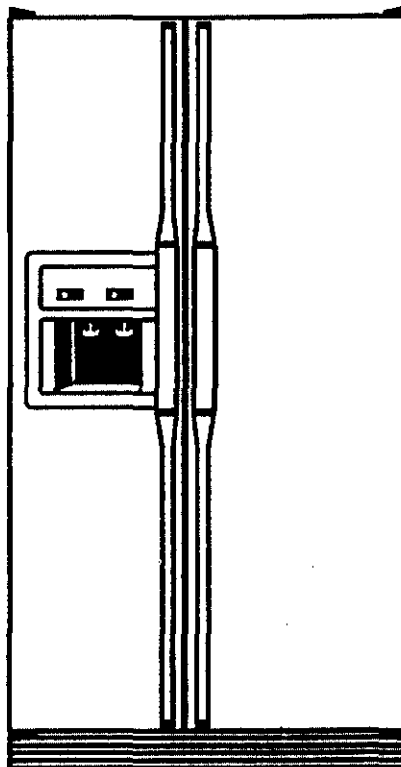

### Outside of Refrigerator

**ACCEPTED**  
with **COMMENTS**  
EPA Letter Dated:  
OCT 24 2003

Under the Federal Insecticide,  
Fungicide, and Rodenticide Act as  
amended, for the pesticide,  
registered under EPA Reg. No.  
**1839-178**

