

Application for Certification - Part 1

2027 Model Year

Common section

These common sections are applicable to all 2027 Test Groups. In accordance with EPA's procedure, the common section is issued with the first application submission for the model year, and will be updated as necessary throughout the model year and at the Part-1 update timing.

Honda Motor Co., Ltd.

Table of Contents

| Section | Contents |
|-------------|--|
| 01.00.00.00 | Correspondence and Communications |
| 02.00.00.00 | Durability Group Description |
| 03.00.00.00 | Evaporative(EVAP)/Refueling Family Description |
| 04.00.00.00 | Durability Procedure Description |
| 05.00.00.00 | Test Group Description |
| 06.00.00.00 | Test Vehicle Description |
| 07.00.00.00 | Test Results |
| 08.00.00.00 | Waiver Statements |
| 09.00.00.00 | OBD System Description |
| 10.00.00.00 | Description of Alternate-fueled Vehicles |
| 11.00.00.00 | AECD Descriptions |
| 12.00.00.00 | Description of vehicles covered by certificate and test parameters |
| 13.00.00.00 | Projected Sales |
| 14.00.00.00 | Request for Approval |
| 15.00.00.00 | Other Information |
| 16.00.00.00 | Confidential Information |
| 17.00.00.00 | California ARB Information |

01.00.00.00 Correspondence and Communications

01.01.00.00 Contact person list

(a) American Honda Motor Co., Inc.

Certification and Compliance (Torrance)
1919 Torrance Blvd., Torrance, CA 90501-2746
FAX Number : (310) 783-3510

| Name | Title | Function | Telephone No. | E-mail Address |
|------------------|---------------------------|---------------------------|----------------|-------------------------------|
| Jesse Deeter | Department Lead | Manager | (937) 620-5517 | jesse_deeter@na.honda.com |
| Gary Wong | Senior Principal Engineer | Tech Leader | (310) 749-8734 | gary_wong@na.honda.com |
| Curtis Yamanaka | Senior Engineer I | Defect Reporting | (310) 781-4044 | curtis_yamanaka@na.honda.com |
| Mitchell Poeung* | Specialist I | Certification, Compliance | (310) 701-5605 | mitchell_poeung@na.honda.com |
| Nicholas Ghysels | Senior Engineer I | Compliance, OBD | (310) 269-5436 | nicholas_ghysels@na.honda.com |
| Shuma Yatabe | Chief Engineer | Manager | (310) 720-7403 | shuma_yatabe@na.honda.com |

Certification and Compliance Testing (Ann Arbor)
3497 Research Park Drive, Ann Arbor, MI 48108
FAX Number : (734) 665-5998

| Name | Title | Function | Telephone No. | E-mail Address |
|---------------|--------------------------|----------------------------|----------------|----------------------------|
| Tommy Chang * | Senior Director | Management | (734) 222-5965 | tommy_chang@na.honda.com |
| Paul DeHart | Manager | Management Cert/In-Use | (734) 222-5961 | paul_dehart@na.honda.com |
| Jason Peabody | Principal Engineer | Certification Test/ In-Use | (734) 222-5966 | jason_peabody@na.honda.com |
| Grant Peel | Engineer | In-Use | (734) 222-5964 | grant_peel@na.honda.com |
| Ryo Koike | Assistant Chief Engineer | Advisor, Testing | (734) 222-5967 | ryo_koike@na.honda.com |

(b) Honda Motor Co., Ltd.

Certification, Regulation, and Compliance
52-1 Hagadai, Haga-machi, Haga-gun, Tochigi, 321-3325 Japan
Fax Number : +81 (28) 687-2144

| Name | Title | Function | Telephone No. | E-mail Address |
|-------------------|-----------------|------------|-------------------|----------------------------|
| Kazutomo Sawamura | General Manager | Management | +81 (28) 687-2166 | kazutomo_sawamura@jp.honda |

* For questions call

01.02.00.00

Mailing address

The corporation's name and address which should appear on the certificate of conformity:

Honda Motor Co., Ltd.
2-3, Toranomom 2-chome, Minato-ku, Tokyo, Japan

The name and address of the person to whom the certificate of conformity and the Executive Order should be mailed:

Jesse Deeter
Department Lead
Certification and Compliance
American Honda Motor Co., Inc.
1919 Torrance Blvd., Torrance, CA 90501-2746

02.00.00.00 Durability group description

| Durability Group Name | | VHNXGPGNN79A | VHNXGPGNN7FA | VHNXGPGNN7FB | VHNXGPGNN93A | VHNXGPGNN95A |
|----------------------------|--------------------------|----------------------|-----------------------|--------------|--------------|--------------|
| Catalyst Information | Code | TW-121 | TW-127 | TW-127, 137 | TW-146, 147 | TW-149 |
| | Specification | 1) | | | | |
| | Grouping Statistic Value | 1) | | | | |
| Combustion Cycle | | 4 Stroke, Otto Cycle | | | | |
| Engine Type | | Piston | | | | |
| Fuel Used | | Gasoline | | | | |
| Basic Fuel Metering System | | Port Fuel Injection | Direct Fuel Injection | | | |

| Durability Group Name | | VHNXGPGNN84A | VHNXGPGNN8EA |
|----------------------------|--------------------------|-----------------------|--------------|
| Catalyst Information | Code | TW-126, 132 | TW-141, 142 |
| | Specification | 1) | |
| | Grouping Statistic Value | 1) | |
| Combustion Cycle | | 4 Stroke, Otto Cycle | |
| Engine Type | | Piston | |
| Fuel Used | | Gasoline | |
| Basic Fuel Metering System | | Direct Fuel Injection | |

1) Refer to 16.02.01.00¹ of this Part 1 common section.

¹ Catalyst specifications

02.00.00.00 Durability group description (contd.)

| | | | | | |
|----------------------------|--------------------------|-----------------------|--------------|--------------|--------------|
| Durability Group Name | | VHNXGPGNN8AA | VHNXGPGNN8CA | VHNXGPGNN90A | VHNXGPGNN96A |
| Catalyst Information | Code | TW-138 | TW-139,140 | TW-144 | TW-150 |
| | Specification | 1) | | | |
| | Grouping Statistic Value | 1) | | | |
| Combustion Cycle | | 4 Stroke, Otto Cycle | | | |
| Engine Type | | Piston | | | |
| Fuel Used | | Gasoline | | | |
| Basic Fuel Metering System | | Direct Fuel Injection | | | |

| | | | | | |
|----------------------------|--------------------------|---|--------------|--------------|--------------|
| Durability Group Name | | VHNXHHGNN91A | VHNXHHGNN98A | VHNXHHGNN99A | VHNXHHGNN9AA |
| Catalyst Information | Code | TW-145 | TW-152 | TW-153 | TW-154 |
| | Specification | 1) | | | |
| | Grouping Statistic Value | 1) | | | |
| Combustion Cycle | | 4 Stroke, Otto Cycle (with Hybrid Electric) | | | |
| Engine Type | | Piston (with Hybrid Electric) | | | |
| Fuel Used | | Gasoline | | | |
| Basic Fuel Metering System | | Direct Fuel Injection | | | |

1) Refer to 16.02.01.00¹ of this Part 1 common section.

¹ Catalyst specifications

02.00.00.00 Durability group description (contd.)

| | | | | |
|----------------------------|--------------------------|---------------------|--------------|--------------|
| Durability Group Name | | VHNXCEINN00A | VHNXEEVNN001 | VHNXEEVNN002 |
| Catalyst Information | Code | N/A | | |
| | Specification | N/A | | |
| | Grouping Statistic Value | N/A | | |
| Combustion Cycle | | Electric/ Fuel Cell | Electric | |
| Engine Type | | Electric | | |
| Fuel Used | | Electric/ Hydrogen | Electric | |
| Basic Fuel Metering System | | N/A | | |

03.00.00.00 Evaporative (EVAP) / Refueling family description

03.01.00.00 EVAP/refueling family grouping parameters

| EVAP/Refueling Family Name | | VHNXR0112DAA | VHNXR0122DAA | | | VHNXR0122DBA |
|-----------------------------------|----------------------|--------------------------------|-----------------------|---------------------|-----------------------|-----------------------|
| Basic Canister Design | Working Capacity (g) | 112 | 121 | 122 | 122 | 122 |
| | System Configuration | 1 1) | | | | |
| | Geometry | Box | | | | |
| | Construction | Inner Partition | | | | |
| | Materials | Plastic | | | | |
| Type of Vapor Storage Device | | EVAP Canister | | | | |
| Fuel System | | Direct Fuel Injection | Direct Fuel Injection | Port Fuel Injection | Direct Fuel Injection | Direct Fuel Injection |
| Refueling Emission Control System | | Integrated System | | | | |
| Fill Pipe Seal Mechanism | | Liquid Seal | | | | |
| Vapor Control System | | N/A | | | | |
| Purge Control System | | Intake Air Volume Proportional | | | | |
| Vapor Hose Material | | Steel, Plastic, Rubber | | | | |
| Fuel Tank Material | | Plastic | | | | |
| Leak Family identifier | | A00 | A00 | A00 | A00 | A00/ D00 |

| EVAP/Refueling Family Name | | VHNXR0149DBA | VHNXR0150DAA | VHNXR0150EAA | VHNXR0150FAA |
|-----------------------------------|----------------------|--------------------------------|--------------|--------------|--------------|
| Basic Canister Design | Working Capacity (g) | 149 | 150 | 150 | 150 |
| | System Configuration | 1 1) | | | |
| | Geometry | Box | | | |
| | Construction | Inner Partition | | | |
| | Materials | Plastic | | | |
| Type of Vapor Storage Device | | EVAP Canister | | | |
| Fuel System | | Direct Fuel Injection | | | |
| Refueling Emission Control System | | Integrated System | | | |
| Fill Pipe Seal Mechanism | | Liquid Seal | | | |
| Vapor Control System | | N/A | | | |
| Purge Control System | | Intake Air Volume Proportional | | | |
| Vapor Hose Material | | Steel, Plastic, Rubber | | | |
| Fuel Tank Material | | Plastic | | | |
| Leak Family identifier | | A00 | A00/ E00 | A00/ E00 | A00 |

1) The identifier "1" means the EVAP/refueling emission control systems use the same (one) canister.

03.02.00.00 ORVR system statement

(a) ORVR system

Honda does not have any new technologies which require the new ORVR safety applications review for 2027MY. Therefore, Honda will carry-over the previous ORVR safety applications, pursuant to CISD-06-06, April 6, 2006.

(b) In-use problems

There are no new in-use problems have occurred since reported in the 2026MY application.

- 04.00.00.00 Durability procedure description
- 04.01.00.00 Durability demonstration procedures for exhaust emissions
Refer to 16.04.01.00¹ of this Part 1 common section.
- 04.02.00.00 Durability demonstration procedures for EVAP/refueling emissions
Refer to 16.04.02.00² of this Part 1 common section.
- 04.03.00.00 Deterioration Factor (DF) information
Refer to Certification Summary Information Report of Part 1 application each test group.
- 04.04.00.00 Equivalency Factor (EF) information
Refer to 04.04.00.00³ of Part 1 application each test group.

¹ Durability demonstration procedures for exhaust emissions

² Durability demonstration procedures for EVAP/refueling emissions

³ Equivalency Factor (EF) information

05.00.00.00 Test group description
Refer to 05.00.00.00¹ of Part 1 application each test group.

06.00.00.00 Test vehicle description
Refer to 06.00.00.00² of Part 1 application each test group.

07.00.00.00 Test result
Refer to 07.00.00.00³ of Part 1 application each test group.

¹ Test Group Description
² Test Vehicle Description
³ Test Result

- 08.00.00.00 Waiver statements
- 08.01.00.00 Emission testing waiver
- 08.01.01.00 Exhaust emission testing

- (a) High altitude testing

Pursuant to 40 CFR 86.1829-15 (c), Honda Motor Co., Ltd. states that;

All vehicles comply with applicable emission standards at high-altitude based on Honda's engineering evaluation of high-altitude emission testing as we deem appropriate.

- (b) 91 RON fuel testing for Regular recommended vehicle

Pursuant to EPA letter VPCD-97-01, January 24, 1997, Honda Motor Co., Ltd. states that;

The city and highway fuel economy test result difference between comparing 91 RON operation and 96 RON operation is within 3%, and there are no significant emissions increases using 91 RON fuel when tested on the FTP or SFTP.

- (c) [Reseeved]

- (d) Emission continuity

Based on engineering evaluation, there is no discontinuity in emission performance measured on Federal Test Procedure in temperature range of 20° F to 86° F.

- (e) Mid-temperature intermediate soak

Pursuant to 40 CFR 86.1829-15(d)(7), Honda states that; the vehicles comply with the mid-temperature intermediate soak standards for the applicable test groups based on our engineering evaluation.

08.01.01.00

Exhaust emission testing (contd.)

(f) Fuel Cell vehicles and Battery Electric vehicles

For Durability testing;

As provided in the following regulations, fuel cell powered electric vehicle using compressed gaseous hydrogen and Battery Electric vehicle is exempted from exhaust durability requirements.

- Pursuant to 40 CFR 86.1815-27(h)(8) "Battery-related requirements for battery electric vehicles and plug-in hybrid electric vehicles," Honda Motor Co., Ltd. states that battery electric vehicles and fuel cell vehicles meet the monitor accuracy requirement, and that battery electric vehicles meet the battery durability requirement.

(g) Fuel Cell vehicles and Battery Electric vehicles (contd.)

For Emission testing;

As provided in the following regulations, fuel cell powered electric vehicle using compressed gaseous hydrogen and Battery Electric vehicle is exempted from exhaust emission requirements.

- Pursuant to subsection (f) of 40 CFR 86.1829-15 "Durability and emission testing requirements; waivers.", Honda Motor Co., Ltd. States that; All Honda Battery Electric vehicles and Fuel Cell vehicles comply with all the requirements of this subpart.

(h) Battery for Hybrid Electric Vehicles

For Durability testing;

Battery control system expands the use of the battery capacity to the level where the capacity will be reduced over useful life. Honda technically evaluated that there would not be substantial impact on CO₂ emission by the battery deterioration. Therefore, Honda does not set the CO₂ DFs for Hybrid Electric Vehicle.

08.01.02.00

EVAP/refueling emission testing

(a) High altitude testing

Pursuant to 40 CFR 86.1829-15 (c), Honda Motor Co., Ltd. states that;

All vehicles comply with the EVAP/refueling emission standards at high-altitude based on Honda's engineering evaluation of high-altitude emission testing as we deem appropriate.

(b) Spitback testing

Pursuant to 40 CFR 86.1829-15 (e)(5), Honda Motor Co., Ltd. states that;

Honda vehicles inherently meet the fuel dispensing spitback standard as part of compliance with the refueling emission standard for the full useful life of the vehicle.

(c) Fuel Cell vehicles and Battery Electric vehicles

As provided in the following regulations, fuel cell powered electric vehicle using compressed gaseous hydrogen and Battery Electric vehicles are exempted from evaporative and refueling emission requirements.

- Pursuant to subsection (f) of 40 CFR 86.1829-15 "Durability and emission testing requirements; waivers.", Honda Motor Co., Ltd. states that; all Honda Battery Electric vehicles and Fuel Cell vehicles comply with all the requirements of this subpart.

(d) Leak Test

Pursuant to 40 CFR 86.1829-15 (e)(4), Honda Motor Co., Ltd. states that;

Fuel systems of Honda vehicles inherently may not exceed an effective leak diameter of 0.02 inches when measured using the procedure specified in 40 CFR 1066.985 based on Honda's engineering evaluation of EVAP leak test as we deem appropriate.

08.02.00.00 Data submittal waiver

08.02.01.00 Exhaust emission testing

(a) Certification Inspection and Maintenance (I/M) compliance

Pursuant to MAC 99-05 issued on June 17, 1999, Honda Motor Co., Ltd. states that;

All vehicles comply with the Accelerated Simulation Mode(ASM) loaded mode and idle mode I/M emission standards based on Honda's engineering evaluation of emission testing.

(b) Formaldehyde

Pursuant to 40 CFR 86.1829-15 (d)(4), Honda Motor Co., Ltd. states that;

Honda's gasoline fueled Otto-cycle vehicles comply with the formaldehyde emission standard based on the engineering evaluation of formaldehyde emission testing as we deem appropriate.

| | |
|-------------|--|
| 09.00.00.00 | OBD system description |
| | Refer to 16.09.00.00 ¹ of this Part 1 common section. |
| 10.00.00.00 | Description of alternate-fueled vehicles |
| | Refer to 10.00.00.00 ² of Part 1 application each test group. |
| 11.00.00.00 | AECD descriptions |
| | Refer to 16.11.00.00 ³ of Part 1 application each test group. |

¹ OBD system description

² Description of alternate-fueled vehicles

³ AECD descriptions

12.00.00.00 Description of vehicles covered by certificate and test parameters

12.01.00.00 Vehicle parameters

Refer to 12.01.00.00¹ of Part 1 application each test group.

12.02.00.00 Test parameters and special test procedure

12.02.01.00 Engine starting procedures

(a) Before starting

(1) Automatic transmission, Continuously Variable transmission (CVT)

(i) Apply the parking brake.

(ii) Make sure the shift lever is in Park. Press on the brake pedal.

(2) Manual transmission

(i) Apply the parking brake.

(ii) Push the clutch pedal down all the way.

(b) Starting the engine

(1) MT, AT and CVT model

Without touching the accelerator pedal, turn the ignition key to the START (III) position or push the ENGINE START/STOP button.

¹ Vehicle parameters

12.02.01.00 Engine starting procedures (Contd.)

(c) Test Procedure for vehicle's tests on dyno and Coasting Down tests

| Test Group | Transmission | Drive Axle | Test Procedure ¹ | | |
|--------------|--------------------|------------|-----------------------------|-----------------------------|-------------------|
| | | | Emission test | | Coast down test |
| | | | R/L derivation | Mode driving | |
| VHNXV01.563A | CVT | FWD | C/D mode (7times) | Certification mode (3times) | C/D mode (7times) |
| VHNXV02.07LC | Fixed Single Speed | FWD | C/D mode (7times) | Certification mode (3times) | C/D mode (7times) |
| VHNXV02.0FEK | CVT | FWD | Certification mode (3times) | Certification mode (3times) | - |
| VHNXV02.0DJC | Fixed Single Speed | FWD | C/D mode (7times) | Certification mode (3times) | C/D mode (7times) |
| VHNXV02.0TWE | 6MT | FWD | Certification mode (3times) | Certification mode (3times) | - |
| VHNXJ01.5N3A | CVT | FWD | C/D mode (7times) | Certification mode (3times) | C/D mode (7times) |
| VHNXJ01.5N3A | CVT | AWD | C/D mode (7times) | Certification mode (3times) | C/D mode (7times) |
| VHNXJ02.0PLD | Fixed Single Speed | FWD | C/D mode (7times) | Certification mode (3times) | C/D mode (7times) |
| VHNXJ02.0PLD | Fixed Single Speed | AWD | C/D mode (7times) | Certification mode (3times) | C/D mode (7times) |
| VHNXV00.0RRG | Fixed Single Speed | FWD | C/D mode (7times) | Certification mode (3times) | C/D mode (7times) |
| VHNXV02.02EC | CVT | FWD | Certification mode (3times) | Certification mode (3times) | - |
| VHNXV02.02EC | CVT | AWD | Certification mode (3times) | Certification mode (3times) | - |
| VHNXT03.5R4C | 10AT | FWD | Certification mode (3times) | Certification mode (3times) | - |
| VHNXT03.51W4 | 10AT | AWD | C/D mode (7times) | Certification mode (3times) | C/D mode (7times) |
| VHNXV03.513D | 10AT | FWD | C/D mode (7times) | Certification mode (3times) | C/D mode (7times) |
| VHNXV03.513D | 10AT | AWD | C/D mode (7times) | Certification mode (3times) | C/D mode (7times) |

¹ Please refer to (d) of this section for procedure of setting each test mode.

12.02.01.00 Engine starting procedures (Contd.)

(c) Test Procedure for vehicle's tests on dynamo and Coasting Down tests (Contd.)

| Test Group | Transmission | Drive Axle | Test Procedure ¹ | | |
|--------------|--------------------|------------|-----------------------------|-----------------------------|-------------------|
| | | | Emission test | | Coast down test |
| | | | R/L derivation | Mode driving | |
| VHNXV01.58ND | CVT | FWD | C/D mode (7times) | Certification mode (3times) | - |
| VHNXV01.58ND | CVT | AWD | C/D mode (7times) | Certification mode (3times) | - |
| VHNXV01.54FE | CVT | FWD | Certification mode (3times) | Certification mode (3times) | - |
| VHNXV02.0TWE | 6MT | FWD | Certification mode (3times) | Certification mode (3times) | - |
| VHNXT03.5CCC | 10AT | FWD | Certification mode (3times) | Certification mode (3times) | C/D mode (7times) |
| VHNXT03.5CCC | 10AT | AWD | Certification mode (3times) | Certification mode (3times) | C/D mode (7times) |
| VHNXV02.09FE | Fixed Single Speed | RWD | C/D mode (7times) | Certification mode (3times) | C/D mode (7times) |
| VHNXV00.0J2A | Fixed Single Speed | RWD | Certification mode (3times) | Certification mode (3times) | C/D mode (7times) |
| VHNXV00.0J2G | Fixed Single Speed | AWD | Certification mode (3times) | Certification mode (3times) | C/D mode (7times) |
| VHNXV00.0J2B | Fixed Single Speed | RWD | Certification mode (3times) | Certification mode (3times) | C/D mode (7times) |
| VHNXV00.0J2H | Fixed Single Speed | AWD | Certification mode (3times) | Certification mode (3times) | C/D mode (7times) |
| VHNXV00.0J1G | Fixed Single Speed | AWD | Certification mode (3times) | Certification mode (3times) | C/D mode (7times) |
| VHNXV00.0J1H | Fixed Single Speed | AWD | Certification mode (3times) | Certification mode (3times) | C/D mode (7times) |

¹ Please refer to (d) of this section for procedure of setting each test mode.

12.02.01.00 Engine starting procedures (Contd.)

(d) Each test mode setting procedure for non-MT models;

- ① Move the shift lever to "P" and press the power switch twice, and conduct the following procedure within 60 seconds:
 - ② Fully open and close the Acc. pedal for (n) times.
 - ③ Move the shift lever to "N" while stepping on the brake pedal
 - ④ Fully open and close the Acc. pedal for (n) times.
 - ⑤ Move the shift lever to "P" while stepping on the brake pedal
 - ⑥ Fully open and close the Acc. pedal for (n) times.
 - ⑦ When successful, message will be displayed on the indicator.
 - ⑧ Press on the brake pedal and press the power switch
 - ⑨ Ready lamp will be indicated and engine will start running.
- *When ignition is turned off, testing mode will be deactivated.

| Acc. Pedal Operation # | Item |
|------------------------|--------------------|
| 3 | Certification mode |
| 7 | C/D mode |

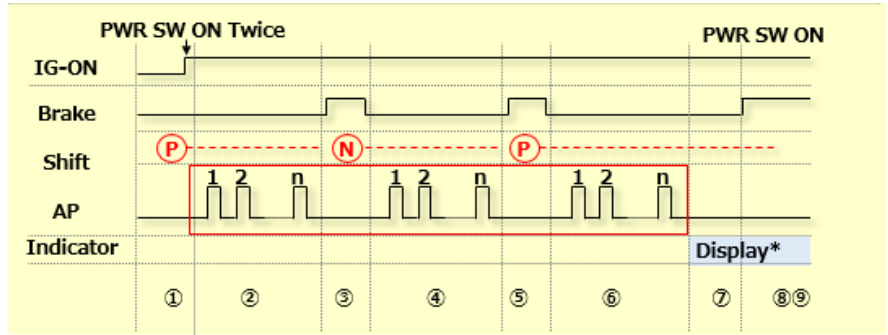

*Message will be displayed on indicator when successful.

12.02.01.00 Engine starting procedures (Contd.)

(d) Each test mode setting procedure for MT models;

- *Parking brake must be applied at all times.
- ① Press the power switch twice without pressing on the clutch pedal and conduct the following procedure within 60 seconds:
 - ② Fully open and close the Acc. pedal for (n) times.
 - ③ While stepping on the brake pedal, step on a clutch pedal.
 - ④ Fully open and close the Acc. pedal for (n) times.
 - ⑤ Release the clutch while stepping on the brake pedal.
 - ⑥ Fully open and close the Acc. pedal for (n) times.
 - ⑦ When successful, message will be displayed on the indicator.
 - ⑧ Step on the brake pedal and press the power switch
 - ⑨ Ready lamp will be indicated and engine will start running.
- *When ignition is turned off, testing mode will be deactivated.

| Acc. Pedal Operation # | Item |
|------------------------|--------------------|
| 3 | Certification mode |
| 7 | C/D mode |

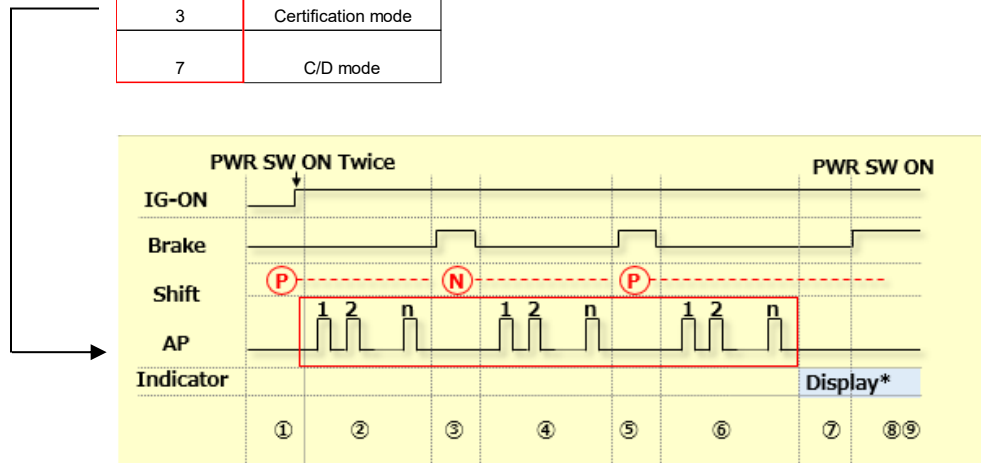

*Message will be displayed on indicator when successful.

12.02.01.00 Engine starting procedures (Contd.)

(e) Vehicle's function under each test mode

| test mode | Drivetrain | Purpose | VSA ABS | AWD | Rr MOT Clutch | Active Grill Shutter (If applicable) | EV I/S | CMBS RDM ACC (Honda SENSING) |
|-----------------------|-------------------------|------------------------------------|------------|-------------------|------------------|--|-------------------|---------------------------------------|
| Certification mode | Except BEV models | Emission/FE test on FWD Dyno | Cancel | Normal Control | - | Normal Control | Normal Control | Cancel |
| | BEV | Driving on Dyno | Cancel | Normal Control | - | Normal Control | - | Cancel |
| C/D mode | Except BEV models | Coasting Down Test on Road | Cancel | Normal Control | - | Close | Cancel | Cancel |
| | BEV | Coasting Down Test on Road | Cancel | Normal Control | - | Disable Temp. control | - | Cancel |

- 12.02.02.00 Shift schedule
Refer to 12.02.02.00¹ of Part 1 application each test group.
- 12.02.03.00 Dynamometer loading information - Road force and dynamometer setting specifications
Refer to 12.02.03.00² of Part 1 application for each test group.
- 12.02.04.00 Fuel Tank Temperature Profile (FTTP)
Refer to 16.12.02.04³ of this Part 1 common section.
- 12.03.00.00 Emission control label
Refer to 12.03.00.00⁴ of Part 1 application for each test group.
- 13.00.00.00 Projected sales
Refer to 16.13.00.00⁵ of this Part 1 common section.

¹ Shift schedule

² Dynamometer loading information - Road force and dynamometer setting specifications

³ Fuel Tank Temperature Profile (FTTP)

⁴ Emission control label

⁵ Projected sales information

14.00.00.00 Request for approval

14.01.00.00 Request for certificate

Refer to 14.01.00.00¹ of the Part 1 application each test group.

14.02.00.00 Request for Executive Order

Refer to 14.02.00.00² of the Part 1 application each test group.

14.03.00.00 Statement of compliance

(a) Tested in accordance with applicable procedures

Refer to 16.14.03.00(a)³ of this Part 1 common section.

(b) Others

(1) Auxiliary Emission Control Device (AECD) – Defeat device

Pursuant to EPA letter VPCD-98-08, May 27, 1998, Honda Motor Co., Ltd. states that;

All test groups are not equipped with AECDs which can be classified as a defeat device as defined in 40 CFR 86.1803-01.

(2) Onboard Diagnostic (OBD) compliance with California requirements

Honda Motor Co., Ltd. states that;

The OBD system installed in each test group meets the full intent of both the Clean Air Act as amended in 1990, section 202(m), and the applicable federal OBD regulations contained in 40 CFR 86.1806-27.

(3) Leak-free of exhaust system

Pursuant to 40 CFR 86.1844-01(d)(16), Honda Motor Co., Ltd. states that;

Honda has conducted an engineering analysis of the complete exhaust system to ensure that the exhaust system has been designed to facilitate leak-free assembly, installation and operation for the full useful life, and leak-free repair for the full useful life.

¹ Request for certificate

² Request for Executive Order

³ Statement of compliance

14.03.00.00

Statement of compliance (contd.)

(c) Others (contd.)

(4) Risk to public safety

Compliance with section 206(a)(3) of CAA described in A/C No. 76 and 76-1.

Honda Motor Co., Ltd. states that any element of design, system or emission control device installed on or incorporated in Honda's new motor vehicles, for the purpose of complying with standards prescribed under section 202 of the Clean Air Act, will not, to the best of Honda's information and belief, cause the emission into the ambient air of pollutants in the operation of its motor vehicles which cause or contribute to an unreasonable risk to public health or welfare except as specifically permitted by the standards prescribed under section 202 of the Clean Air Act. Honda Motor Co., Ltd. further states that any element of design, system or emission control device installed on or incorporated in Honda's new motor vehicles, for the purpose of complying with standards prescribed under section 202 of the Clean Air Act, will not, to the best of Honda's information and belief, cause or contribute to an unreasonable risk to public safety.

The term pollutant means:

- a. Diesel particulates
- b. Nickel
- c. MMT combustion products
- d. Ammonia
- e. Sulfates
- f. Hydrogen sulfide
- g. Hydrogen cyanide
- h. Ruthenium combustion products
- i. Nitrosamines

or any other pollutant which Honda Motor Co., Ltd. has identified can reasonably be expected to be emitted from these vehicles.

(5) US06 - Lean Best Torque (LBT) Air-to-Fuel (A/F) ratio control

Honda Motor Co., Ltd. states that;

All vehicles comply with US06 - Lean Best Torque (LBT) Air-to-Fuel (A/F) ratio control requirement specified in 40 CFR 86.1811-17 (d) (1).

15.00.00.00 Other information

15.01.00.00 Fee filing form

Refer to 15.01.00.00¹ of Part 1 application each test group.

¹ Fee filing form

17.00.00.00-17.09.00.00

[Reserved]

17.10.00.00 California Emissions Warranty Statement

(a) Honda ICE

California Emissions Warranties

In addition to the Federal Emissions Warranties, the California Emissions Warranties that follow cover all vehicles registered and normally driven in California, Colorado, Connecticut, Delaware, Maine, Maryland, Massachusetts, Minnesota, Nevada, New Jersey, New Mexico, New York, Oregon, Pennsylvania, Rhode Island, Vermont, Virginia, Washington, and Washington D.C..

Time and Mileage Period

These warranties begin on the date the vehicle is delivered to the first purchaser other than an authorized Honda automobile dealer, or the date it is first used as a demonstrator, lease, or company vehicle, whichever comes first. The duration of the warranties may vary depending on vehicle model and location where the vehicle is registered and normally operated. Refer to the Emissions Warranty Parts List at the back of

this booklet for information on the warranty duration of the systems that receive extended coverage.

Your Warranty Rights and Obligations

The California Air Resources Board and Honda are pleased to explain the emissions control systems warranties on your 2027 Honda vehicle. In California, new motor vehicles must be designed, built, and equipped to meet the state's stringent anti-smog standards. Honda must warrant the emissions control systems on your vehicle for the periods of time listed here provided there has been no abuse, neglect, or improper maintenance of your vehicle.

Your emissions control systems may include parts such as the carburetor or fuel injection system, the ignition system, catalytic converter, and engine computer. Also included may be hoses, belts, connectors, and other emissions-related assemblies.

Where a warrantable condition exists, Honda will repair your vehicle at no cost to you, including diagnosis, parts, and labor.

Manufacturer's Warranty Coverage

For **3 years or 50,000 miles**, or a longer period of time or mileage, whichever comes first:

- If your vehicle fails a Smog Check inspection, all necessary repairs and adjustments will be made by Honda to ensure your emissions control system **PERFORMANCE WARRANTY**.
- If any emissions-related part on your vehicle is defective, the part will be repaired or replaced by Honda. This is your short-term emissions control system **DEFECTS WARRANTY**.

Refer to the Emissions Warranty Parts List in the back of this booklet for more information on the warranty duration and the emissions systems that receive extended coverage.

California Emissions Warranties

For **7 years or 70,000 miles**, whichever comes first:

If an emissions-related part listed in this warranty booklet specially noted with coverage for 7 years or 70,000 miles is defective, the part will be repaired or replaced by Honda. This is your long-term emissions control system **DEFECTS WARRANTY**.

Refer to the Emissions Warranty Parts List in the back of this booklet for model specific information on the warranty duration and the emissions systems that receive extended coverage.

Owner's/Lessee's Warranty Responsibilities

As the vehicle owner or lessee, you are responsible for the performance of the required maintenance listed in your owner's manual. Honda recommends that you retain all receipts covering maintenance on

your vehicle, but Honda cannot deny warranty solely for the lack of receipts or for your failure to ensure the performance of all scheduled maintenance.

You are responsible for presenting your vehicle to an authorized Honda automobile dealer as soon as a problem exists. The warranty repairs should be completed in a reasonable amount of time, not to exceed 30 days.

As the vehicle owner or lessee, you should also be aware that Honda may deny warranty coverage if your vehicle or a part has failed due to abuse, neglect, improper maintenance, or unapproved modifications. If you have any questions regarding your warranty rights and responsibilities, you should contact Honda Automobile Customer Service (see the inside front cover of this booklet).

California residents may also contact the California Air Resources Board.

California Air Resources Board
4001 Iowa Avenue
Riverside, CA 92507

The California Emissions Control Systems Defects and Emissions Performance warranties are in addition to the Honda New Vehicle Limited Warranty. These warranties are given only to the owner or lessee of a 2027 model year Honda automobile distributed by American Honda, through the Honda Automobile Division, for a vehicle registered and operated in California or other states that have adopted California emissions warranty regulations.

17.10.00.00 California Emissions Warranty Statement (contd.)

(a) Honda ICE (contd.)

| | | |
|--|--|---|
| California Emissions Warranties | | |
| <p>If an authorized Honda automobile dealer cannot repair your vehicle or honor your claim within a reasonable period of time, contact Honda Automobile Customer Service for assistance (see the inside front cover of this booklet). If you are not satisfied with the way in which a claim was resolved by Honda, in California, you may write directly to:</p> <p>California Air Resources Board 4001 Iowa Avenue Riverside, CA 92507</p> <p>Your Responsibilities</p> <p>To qualify for coverage under the defects and performance warranties, you should operate and maintain your 2027 Honda automobile according to the requirements on page 35 of this warranty booklet and/or the information provided by the Maintenance Minder™.</p> | <p>This schedule is designed to keep your vehicle's emissions control systems functioning properly by maintaining your vehicle in peak operating condition.</p> <p>Honda will not deny a claim for emissions warranty coverage because you did not generally maintain the vehicle, or do not have maintenance records to show that you did. However, any part that fails as a result of abuse, misuse, unapproved modification, use of improper parts, or failure to perform required maintenance affecting the failed part will not be covered under this warranty.</p> <p>Honda recommends that only parts supplied by Honda or equivalent parts be used to repair your vehicle.</p> | <p>Maintenance, replacement, or repair of emissions control devices and systems may be done by any automotive repair establishment or individual.</p> <p>Under normal circumstances, Honda will pay for warranty repairs only when they are performed at an authorized Honda automobile repair facility. However, in an emergency situation, the repair of emissions control devices or systems may be done by any automotive repair establishment or individual or by the owner, using an equivalent, non-Honda replacement part.</p> <p>An emergency situation is considered to exist if an authorized Honda repair facility is not reasonably available, when a warranted part is not available within 30 days, or when an authorized Honda automobile repair facility is unable to complete a repair within 30 days.</p> |
| <p>20 Your Warranties in Detail</p> | | |

(b) Acura ICE

TBD

(c) Honda BEV

TBD

(d) Honda CR-V e:FCEV

TBD