



WUHAN LOTUS CARS CO., LTD. APPLICATION FOR CERTIFICATION – PART I

Model Year: 2026

Test Group: TWHNV00.0LZB

Durability Group: TWHNEEVNNLZB

Evaporative Family: Not Applicable

Durability Group Description: Electric Vehicle / BEV / ZEV

Test Group Description: Electric Vehicle / BEV / ZEV

Different test groups based on battery
and Electric motor configuration

Applicable Standards: FEDERAL Tier 3 BIN 0

CALIFORNIA ZEV

Carlines Covered: ELETRE R Long range,

ELETRE R Performance

Vehicles Tested: GIC_C10_6101,

GIC_C10_6114

For Question, Contact: Danielle M. House

Phone: +1 (734) 209 6660

Email: Danielle.house@lotuscars.com



Table of Contents:

Section 01	Correspondence and Communication
Section 02	Durability Group Description
Section 03	Evaporative / Refueling Family Description
Section 04	Durability Procedure Description
Section 05	Test Group Description
Section 06	Test Vehicle Description
Section 07	Test Results
Section 08	Manufacturer Statements
Section 09	OBD System Description
Section 10	Description of Alternate-fueled Vehicles
Section 11	AECD Description
Section 12	Description of vehicles covered by certificate and test parameters
Section 13	Projected Sales
Section 14	Request for Certificate
Section 15	Other Information
Section 16	Confidential Information



01. Correspondence and Communication

Refer to Section 16.01 of this Test Group Application.



02. Durability Group Description

Durability Group Name:	TWHNEEVNNLZB
Combustion Cycle:	Electric
Engine Type:	Electric Motor
Fuel Used:	Power Grid Electricity



03. Evaporative / Refueling Family Description

Not applicable. Battery Electric Vehicles.



04. Durability Procedure Description

Not applicable. Battery Electric Vehicles.



05. Test Group Description

Durability Group Name:	TWHNEEVNNLZB
Test Group Name:	TWHNV00.0LZB
Electric Motor Type:	Front: AC, 3 Phase, Synchrony, With Permanent Magnets Rear: AC, 3 Phase, Synchrony, With Permanent Magnets
Electric Motor Size:	Total: 905 HP
Battery Type:	Lithium-ion Battery
Battery Capacity:	158 Ah
Battery rated voltage:	708 V
Vehicle Class	LDV
Federal Emissions Standards Class	Tier 3 BIN 0
California Emissions Standards Class	LEVIII ZEV



06. Test Vehicle Description

06.01. Test Vehicles

Vehicle ID	VIN	Model	Purpose	Tests Performed
GIC_C10_6114	#1029	ELETRE R Long Range	Range/Energy	5-Cycle
GIC_C10_6101	#1027	ELETRE R Performance	Range/Energy	5-Cycle



06.02. Test Parameters, Instruction

Engine Start Operation

- 1) After using the effective key to unlock the car and opening the doors, the instrument cluster and the Center Stack Display (CSD) will light up, and the car will automatically power on.
- 2) If the driver is using the card key to unlock and enter the car, you need to place the card key in the wireless charging induction area. If the brake pedal is depressed and the gear is shifted to R or D position, the car starts in the driving mode.
- 3) After the driver enters the vehicle with the key fob/digital key, the vehicle starts by pressing the brake pedal. If the gear is shifted to R or D position, the car is in driving mode.
- 4) When the vehicle is in drivable mode, the READY indicator on instrument cluster will be illuminated.
- 5) After the vehicle reaches the READY state, you can put the card key in a different location in the vehicle if the phone's wireless charging function is required.
- 6) At conclusion of the driving cycle, set gear selector to P.
- 7) If you have closed all doors (including the bonnet and the tailgate) and are about to leave the car with the key, you can power off the car in the following ways:
 - Lock the car with the key.
 - If the driver door is not opened within 5 minutes, the car will automatically turn off the power.



Transmission Shift Operation

- Flick the gear lever to switch to different gears, while the corresponding gear information is displayed on the instrument cluster.
- Reverse (R): When the vehicle is parked, press the brake pedal, long toggle the gear lever forward and release it, and switch gears to R.
- Neutral (N): When the gear is in D or R, the lever is flicked forward or backwards shortly and the gear switches to N.
- Drive (D): When the vehicle is parked, press the brake pedal, long toggle the gear lever backwards and release it, and switch gears to D.
- Park (P): After the vehicle is parked, press the P button, the gear switches to P gear, and the electronic parking brake is automatically activated.

Selectable mode

All selectable modes to be left in default positions.

Cooling fan

One road-speed fan, centered upright, front of vehicle.

Drive mode:

All models are AWD.



06.03. Battery Charge Procedures

The charging port is located at the front left side of the vehicle, and the charging port cover can be opened or closed in the following ways:

- Unlock the vehicle with a valid key, press the outside of the charging port cover, and the cover will open automatically; press the cover closing button or lock the vehicle, and the cover will be closed automatically.



- Click the  icon in the CSD, select the integrated charging port cover switch to automatically open or close the cover.





During the charging, the charging status of the car can be known through the following indication:

- Instrument cluster
- Centre Stack Display (CSD)
- Mobile APP
- Charging port indicator

The colors legend is described below:

- White (always on): Indicates that the indicator lamp is illuminated automatically when the charging port cover is opened.
- Green (flash): The charging is normal within a period of time after the charging plug is connected.
- Green: The charge is complete and lasts for 2 minutes.
- Orange (always on): Indicates that the battery preheating function is activated.
- Red: Failure occurred for 2 min during charging.



Charging with charging pile:

- Remove the charging plug from the charging pile, and insert it into the integrated charging port properly, at which point the electronic lock will be enabled automatically.
- Operate according to instructions on the charging pile to start charging the car.



06.04. Voltage and Current Measurement Procedures

These instructions apply to certification vehicles only. Voltage and current analysis on production vehicles can only be accomplished via control unit communications.

How to Install the current clamps in HVB and LVB system

The vehicle is prepared to fit the clamps avoiding the insulate shield current measurement effect.

Total of 4 x Current clamps must be installed: 2 x HVB (front and rear battery outlet) and 2 x LVB outlet.

A HVB disconnect procedure is recommended after lifting the vehicle with a 2-post lift to better access to HVB output cables from the battery, especially in the rear side.

- a) Open front bonnet and rear trunk and cheat both latches.
- b) Open windows and lock the vehicle.
- c) Disconnect HVB service plug located in front engine bay.
- d) Leave the vehicle 5 minutes asleep.
- e) Disconnect 12V Lithium battery located in rear trunk.
- f) Disconnect 12V Lead battery located in rear trunk.
- g) Verify there is no Voltage through the HVB instrumented cable located in the front engine bay.
- h) Install 2 x clamps for LVB. Exact locations are marked on rear trunk and detailed below.





- i) Install 2 x clamps for HVB (front and rear outlet). In case of Zeus e-motor rear configuration, 2 x HVB connectors must be removed before fitting the current clamp.

How to acquire the voltage

The vehicle is prepared with voltage banana plugs to be connected to Hioki power analyzer.

The HVB banana plugs are located inside a sealed bag in the front engine bay.



The LVB banana plugs are located inside a sealed bag under passenger seat footage.





06.05. Description of the Climate Control System

The automatic four-zone A/C control system is automatically controlled according to the pre-set temperature in the vehicle, and the temperature, air volume and air direction of the left front, right front, left rear and right rear climate area in the vehicle can be adjusted separately according to the ambient temperature, interior temperature, sunshine, air quality and window fog.

When setting the climate of individual zone manually, the climate of other zones can still be in auto mode.

The air conditioning compressor not only provides cooling for the passenger compartment, but also cools the battery. Therefore, in hot weather, even if the air conditioning is turned off, the compressor may still be working, which is a normal phenomenon. This is to maintain the battery in an optimal temperature range to ensure longer service life and optimal performance.

Climate control systems use R1234yf refrigerant.



Front climate control interface settings



ION switch: click to turn on or off the negative oxygen ion function of the A/C.



Streaming mirror defrosting/defogging switch: click to turn on or off the exterior rear view mirror display defrost/defog function.



A/C switch: click to turn on or off the A/C refrigeration system. In auto mode, the A/C mode is on by default.

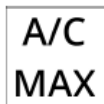

A/C MAX switch: after this switch is turned on by clicking, the A/C temperature will be automatically adjusted to the lowest and the A/C air volume will be adjusted to the maximum.



Front windscreen defrost/defog switch: click on or off the maximum defrost/defogging function to quickly remove ice or fog from the front windscreen and side windows.



Four-zone sync switch: after the four-zone sync is activated by clicking, the temperature, air volume, blowing mode and auto mode in the vehicle can be adjusted synchronously from the driver side; after this feature is deactivated, each area can be adjusted separately. This function needs to be manually activated again every time the vehicle is started.



Rear windscreen and outside mirror defrost/defogging switches: click to turn on or off the defrost/defogging functions of rear windscreen and outside mirrors.



Internal circulation switch: click to activate the internal circulation of air in the vehicle.



External circulation switch: click to activate the external circulation of air in the vehicle.



Automatic circulation mode: when the A/C is turned to Auto mode, the internal/external circulation will be automatically activated.



ECO switch: click to turn on or off the economic operation mode of the A/C.



Window blowing mode: air flow blows front windscreen and front side window.



Face blowing mode: when the air outlet is opened, the air flow blows out from the centre and side air outlets, blowing the side faces of the driver and front passenger.



Foot blowing mode: air flow blows to the side feet of the driver and front passenger.



Click "-" or "+" switch on both sides of the fan to adjust the air volume at the corresponding side respectively. Adjust the air volume to reduce or increase by 1 gear, the higher the value, the greater the air volume.



Turn on auto mode and the air volume will be automatically adjusted.



Front A/C system switch: click to turn the front A/C system on or off.



Air quality system: click to view the working status of the air quality system.



Rear climate control interface settings

There is a rear A/C control panel on the center armrest of the rear seat. Some models have a rear A/C control panel in the rear seat center armrest.



Face blowing mode: when the air outlets are opened, the air flow blows out from the centre and side air outlets, blowing the faces of the rear passengers.



Feet blowing mode: air flow blows towards the feet of the rear passengers.



Auto mode: after clicking it on, the A/C system automatically controls the temperature, air volume and air direction according to the temperature you set in the vehicle, and maintains the temperature in the vehicle at the temperature value you set.



Click "-" or "+" switch on both sides of the fan to adjust the air volume at the corresponding side respectively. Adjust the air volume to reduce or increase by 1 gear, the higher the value, the greater the air volume.



Turn on auto mode and the air volume will be automatically adjusted.



Rear A/C system switch: click to turn the rear A/C system on or off.



06.06. BEV Proper and Safe Operation

ELETRE is driven by high voltage batteries, which may result in worse conditions such as high voltage electricity leakage, damage to battery pack, leakage of chemical liquid, etc. in the event of serious collisions. Therefore, the emergency rescue personnel should wear appropriate protective equipment to ensure personal safety when rescuing on the vehicle.

LOTUS supplies safety recommendations and special precautions and warnings for rescue personnel such as towing method, emergency rescue procedures, release method of high-voltage system, wading rescue and rescue of vehicle or fire. This detailed documentation can be found in the vehicle handbook.



06.07. Dynamometer Parameters

Vehicle	ETW	Target			Setting		
		A [lbf]	B [lbf/mph]	C [lbf/mph ²]	A [lbf]	B [lbf/mph]	C [lbf/mph ²]
GIC_C10_6114	6000	52.54	0.0264	0.0230	-9.08	-0.0365	0.0220
GIC_C10_6101	6000	46.58	0.4928	0.0187	-9.89	0.0579	0.0200



07. Test Results

07.01. Exhaust & Evaporative Standards

	Federal	California
Exhaust Emissions Standards	Tier 3 Bin 0	ZEV
Evaporative Standards	N.A.	N.A.

07.02. Certification tests and Test procedures

LOTUS chose the 5-cycle test procedures according to SAE J1634-2017, Appendix B, Option 2, for fuel economy labeling. The following certification tests IDs are detailed below for Range, Energy consumption and adjustment factor determination.

5-Cycle based Range & Energy Consumption	ELETRE R Long Range GIC_C10_6114#1029	ELETRE R Performance GIC_C10_6101#1027
MCT	SWHN10086682	SWHN10086725
UDDS	SWHN10086780	SWHN10086781
HW	SWHN10086803	SWHN10086804
US06	SWHN10086807	SWHN10086816
SC03	SWHN10086819	SWHN10086820
COLD UDDS 20F	SWHN10086823	SWHN10086824

For 5-Cycle Range and Energy Consumption results, please refer to 16.03 of this Test Group Application.

Certification Summary Information Report

Test Group	TWHNV00.0LZB	Evaporative/Refueling Family	--
-------------------	--------------	-------------------------------------	----

Models Covered by this Certificate

Carline Manufacturer	Division	Carline	Certification Region Code(s)	Drive System	Trans - Type	- # of Gears	Trans - Lockup
Wuhan Lotus Cars Co., Ltd	1 - Wuhan Lotus Cars	802 - ELETRE R Performance	California + CAA Section 177 states	4-Wheel Drive	Automatic	2	No
Wuhan Lotus Cars Co., Ltd	1 - Wuhan Lotus Cars	801 - ELETRE R Long Range	California + CAA Section 177 states	4-Wheel Drive	Automatic	2	No
Wuhan Lotus Cars Co., Ltd	1 - Wuhan Lotus Cars	802 - ELETRE R Performance	Federal	4-Wheel Drive	Automatic	2	No
Wuhan Lotus Cars Co., Ltd	1 - Wuhan Lotus Cars	801 - ELETRE R Long Range	Federal	4-Wheel Drive	Automatic	2	No

Engine Description

Hybrid Type	--	Hybrid Description	--
Engine Type	--	Mfr Engine Description	--
Engine Block Arrangement	--	Mfr Engine Block Arrangement Description	--
Camless Valvetrain Indicator	--	Oil Viscosity/Classification	
Number of Cylinders/Rotors	--	Mechanically Variable Compression Ratio Indicator	--

After Treatment Device(s) (ATD)

Mfr After Treatment Device (ATD) Comments	--
Direct Ozone Reduction (DOR) Device	--
Mfr Emission Control Device Comments	--

Official Test Numbers

Test Group	Fuel	FTP	US06	SC03	Cold CO	Highway	EPA City Litmus Value	EPA City Litmus Threshold	EPA Highway Litmus Value	EPA Highway Litmus Threshold	CREE Weighting Factor
Electricity		--	--	--	--	--	--	--	--	--	--

Certification Summary Information Report

Test Group	TWHNV00.0LZB	Evaporative/Refueling Family	--
Hybrid Electric Vehicle And Fuel Cell Information			
Rechargeable Energy Storage System	Battery(s)	Rechargeable Energy Storage System, if Other	--
Battery Type	Lithium Ion	Number of Battery Packs	1
Total Voltage of Battery Packs	708	Battery Energy Capacity	158
Battery Specific Energy	168	Battery Charger Type	On-Board
Number of Capacitors	--	Capacitor Rating (In Farads)	--
Mfr Capacitor Comments	--		
Hydraulic System Description	--		
Regenerative Braking Type	Electrical Regen Brake		
Regenerative Braking Source	Both	Driver Controlled Regenerative Braking	Yes
Mfr Regenerative Braking Description	--		
Drive Motor(s)/Generator(s)	2		
Motor/Generator Type 1	AC 3ph permanent magnet rear	Rated Motor/Generator Power	450
Motor/Generator Type 2	AC 3ph permanent magnet front	Rated Motor/Generator Power	225
Mfr Fuel Cell Description	--		
Fuel Cell On-Board H2 Storage Capacity (kg)	--	Usable H2 Fill Capacity (kg)	--
Mfr Hybrid Electric/ Electric Vehicle Comments	--		

Certification Summary Information Report

Test Group		TWHNV00.0LZB			Evaporative/Refueling Family			--
Dynamometer Coefficients:								
		Target Coefficients			Set Coefficients			EPA Calculated Total Road Load Horse Power for City/Highway/Evap Coefficients
Coefficient Category	A (lbf)	B (lbf/mph)	C (lbf/mph**2)	A (lbf)	B (lbf/mph)	C (lbf/mph**2)		
City/Highway/Evap	46.58	0.4928	0.0187	-9.89	0.0579	0.02	15.7	
Cold CO	51.24	0.542	0.0206	-24.86	-0.0329	0.0219	N/A	
US06	46.58	0.4928	0.0187	-9.89	0.0579	0.02	N/A	
Emission Control Device Comments		--						
Manufacturer Test Vehicle Comments		This is 2025 ELETRE R Performance; Front Motor Power - 225kW (EDS1 motor); Rear Motor Power - 450 kW (Zeus motor) Number of transmission gears on front motor EDS1: 1 Number of transmission gears on rear motor Zeus: 2 N/V ratio on front motor EDS1: 9.187 N/V ratio on rear motor Zeus: 1st 13.645 , 2nd 7.155						

Certification Summary Information Report

Test Group	TWHNV00.0LZB	Evaporative/Refueling Family	--
Test #	SWHN10086781	Test Procedure	2 - CVS 75 and later (w/o can. load)
Exhaust Test # for this Evap Test	--	Test Fuel Type	62 - Electricity
Test Date	04/19/2024	Fuel	Electricity
Fuel Batch ID	--	Fuel Calibration Number	--
Vehicle Class	LDV/Passenger Car	DF Type	Mfr. Assigned
Verify Test Lab ID	Applus IDIADA Automotive Technology		
E10 Evaporative Test Measurement Method	--		
Test Start Odometer Reading	7862	Odometer Units	K
4WD Test Dyno	Yes	Diesel Adjustment Factor Usage	--
State of Charge Delta	No	Road Speed Fan Usage	Yes
Drive Cycle Speed Tolerance Criteria	Used Part 1066 (+/- 2.0 mph, +/- 1.0 sec)		

Test Results

Test Result Name	Unrounded Test Result	Verify Calculated FE Equivalent Value (kilowatt-hour per 100 miles)
ACT-DISTANCE (Actual Distance Driven (miles))	14.843	--
METHANE (CH4 - Methane)	0	--
CO (Carbon Monoxide)	0	--
DT-ASCR (Drive Trace Absolute Speed Change Rating)	0	--
DT-EER (Drive Trace Energy Economy Rating)	0	--
DT-IWRR (Drive Trace Inertia Work Ratio Rating)	0	--
MFR FE (Manufacturer Fuel Economy)	30.78	109.502924
NOX (Nitrogen Oxide)	0	--
N2O (Nitrous Oxide)	0	--
HC-NM (Non-methane Hydrocarbon)	0	--
NMOG (Non-methane organic gases)	0	--

Test Result Name	Unrounded Test Result	Verify Calculated CREE/OPT-CREE
Carbon-Related Exhaust Emissions	0	0
Optional Carbon-Related Exhaust Emissions	0	0

Test Result Name	Unrounded Test Result	Verify Calculated CO2
Carbon dioxide	0	--

Manufacturer Test Comments

DC energy consumption Phase1 = 336.1 Wh/mi; Phase2 = 291.9 Wh/mi; Phase3 = 319.8 Wh/mi; Phase4 = 289.0 Wh/mi Drive trace indicators Ph1 ASCR (%) = 3.266; EER (%) = 2.163; IWR (%) = 3.330 Ph2 ASCR (%) = 1.606; EER (%) = 1.036; IWR (%) = 2.897 Ph3 ASCR (%) = 0.148; EER (%) = 0.697; IWR (%) = -0.034 Ph4 ASCR (%) = 1.379; EER (%) = 0.834; IWR (%) = 1.961

Certification Summary Information Report

Test Group		TWHNV00.0LZB				Evaporative/Refueling Family				--		
Certification Region	Useful Life	Standard Level	Emission Name	Rounded Result	RAF	NMOG/NM HC Ratio	Diesel Adjustment Factor	Add DF	Mult DF	Certification Level	Standard	Pass/Fail
Fed	150,000 miles	Federal Tier 3 Bin 0	CO	0.0	--	--	--	0	--	0	0	Pass
Fed	150,000 miles	Federal Tier 3 Bin 0	CREE	0	--	--	--	0	--	0	--	--

NOTE: For Non-charge depleting tests, the Rounded Result for CREE/OPT-CREE Emission names are Verify-calculated values.

Certification Summary Information Report

Test Group	TWHNV00.0LZB	Evaporative/Refueling Family	--
Test #	SWHN10086804	Test Procedure	3 - HWFE
Exhaust Test # for this Evap Test	--	Test Fuel Type	62 - Electricity
Test Date	04/19/2024	Fuel	Electricity
Fuel Batch ID	--	Fuel Calibration Number	--
Vehicle Class	LDV/Passenger Car	DF Type	Mfr. Assigned
Verify Test Lab ID	Applus IDIADA Automotive Technology		
E10 Evaporative Test Measurement Method	--		
Test Start Odometer Reading	7862	Odometer Units	K
4WD Test Dyno	Yes	Diesel Adjustment Factor Usage	--
State of Charge Delta	No		
Drive Cycle Speed Tolerance Criteria	Used Part 1066 (+/- 2.0 mph, +/- 1.0 sec)	Road Speed Fan Usage	Yes

Test Results

Test Result Name	Unrounded Test Result	Verify Calculated FE Equivalent Value (kilowatt-hour per 100 miles)
ACT-DISTANCE (Actual Distance Driven (miles))	10.234	--
METHANE (CH4 - Methane)	0	--
CO (Carbon Monoxide)	0	--
DT-ASCR (Drive Trace Absolute Speed Change Rating)	-0.355	--
DT-EER (Drive Trace Energy Economy Rating)	0.126	--
DT-IWRR (Drive Trace Inertia Work Ratio Rating)	-0.984	--
MFR FE (Manufacturer Fuel Economy)	31.08	108.4459459
NOX (Nitrogen Oxide)	0	--
N2O (Nitrous Oxide)	0	--
HC-NM (Non-methane Hydrocarbon)	0	--
NMOG (Non-methane organic gases)	0	--

Test Result Name	Unrounded Test Result	Verify Calculated CREE/OPT-CREE
Carbon-Related Exhaust Emissions	0	0
Optional Carbon-Related Exhaust Emissions	0	0

Test Result Name	Unrounded Test Result	Verify Calculated CO2
Carbon dioxide	0	--

Manufacturer Test Comments

DC energy consumption = 310.8 Wh/mi

Certification Summary Information Report

Test Group		TWHNV00.0LZB				Evaporative/Refueling Family				--		
Certification Region	Useful Life	Standard Level	Emission Name	Rounded Result	RAF	NMOG/NM HC Ratio	Diesel Adjustment Factor	Add DF	Mult DF	Certification Level	Standard	Pass/Fail
Fed	150,000 miles	Federal Tier 3 Bin 0	CO	0.0	--	--	--	0	--	0	0	Pass
Fed	150,000 miles	Federal Tier 3 Bin 0	CREE	0	--	--	--	0	--	0	--	--

NOTE: For Non-charge depleting tests, the Rounded Result for CREE/OPT-CREE Emission names are Verify-calculated values.

Certification Summary Information Report

Test Group	TWHNV00.0LZB	Evaporative/Refueling Family	--
Test #	SWHN10086816	Test Procedure	90 - US06
Exhaust Test # for this Evap Test	--	Test Fuel Type	62 - Electricity
Test Date	04/19/2024	Fuel	Electricity
Fuel Batch ID	--	Fuel Calibration Number	--
Vehicle Class	LDV/Passenger Car	DF Type	Mfr. Assigned
Verify Test Lab ID	Applus IDIADA Automotive Technology		
E10 Evaporative Test Measurement Method	--		
Test Start Odometer Reading	7862	Odometer Units	K
4WD Test Dyno	Yes	Diesel Adjustment Factor Usage	--
State of Charge Delta	No		
Drive Cycle Speed Tolerance Criteria	Used Part 1066 (+/- 2.0 mph, +/- 1.0 sec)	Road Speed Fan Usage	Yes

Test Results

Test Result Name	Unrounded Test Result	Verify Calculated FE Equivalent Value (kilowatt-hour per 100 miles)
ACT-DISTANCE (Actual Distance Driven (miles))	7.965	--
METHANE (CH4 - Methane)	0	--
CO (Carbon Monoxide)	0	--
DT-ASCR (Drive Trace Absolute Speed Change Rating)	0	--
DT-EER (Drive Trace Energy Economy Rating)	0	--
DT-IWRR (Drive Trace Inertia Work Ratio Rating)	0	--
MFR FE (Manufacturer Fuel Economy)	39.66	84.9848714
NOX (Nitrogen Oxide)	0	--
N2O (Nitrous Oxide)	0	--
HC-NM (Non-methane Hydrocarbon)	0	--
NMOG (Non-methane organic gases)	0	--

Test Result Name	Unrounded Test Result	Verify Calculated CREE/OPT-CREE
Carbon-Related Exhaust Emissions	0	--
Optional Carbon-Related Exhaust Emissions	0	--

Test Result Name	Unrounded Test Result	Verify Calculated CO2
Carbon dioxide	0	--

Manufacturer Test Comments

DC energy consumption Phase 1 (Highway) = 419.2 Wh/mi; Phase 2 (City) = 390.3 Wh/mi Drive trace indicators Ph city ASCR (%) = -1.618; EER (%) = 0.849; IWR (%) = -1.405 Ph hw ASCR (%) = -1.405; EER (%) = -2.732; IWR (%) = -1.694

Certification Summary Information Report

Test Group	TWHNV00.0LZB	Evaporative/Refueling Family	--
-------------------	--------------	-------------------------------------	----

Certification Region	Useful Life	Standard Level	Emission Name	Rounded Result	RAF	NMOG/NM HC Ratio	Diesel Adjustment Factor	Add DF	Mult DF	Certification Level	Standard	Pass/Fail
Fed	150,000 miles	Federal Tier 3 Bin 0	CO	0.0	--	--	--	0	--	0	0	Pass

Certification Summary Information Report

Test Group	TWHNV00.0LZB	Evaporative/Refueling Family	--
Test #	SWHN10086820	Test Procedure	95 - SC03
Exhaust Test # for this Evap Test	--	Test Fuel Type	62 - Electricity
Test Date	05/02/2024	Fuel	Electricity
Fuel Batch ID	--	Fuel Calibration Number	--
Vehicle Class	LDV/Passenger Car	DF Type	Mfr. Assigned
Verify Test Lab ID	Applus IDIADA Automotive Technology		
E10 Evaporative Test Measurement Method	--		
Test Start Odometer Reading	8028	Odometer Units	K
4WD Test Dyno	Yes	Diesel Adjustment Factor Usage	--
State of Charge Delta	No		
Drive Cycle Speed Tolerance Criteria	Used Part 1066 (+/- 2.0 mph, +/- 1.0 sec)	Road Speed Fan Usage	Yes

Test Results

Test Result Name	Unrounded Test Result	Verify Calculated FE Equivalent Value (kilowatt-hour per 100 miles)
ACT-DISTANCE (Actual Distance Driven (miles))	3.566	--
METHANE (CH4 - Methane)	0	--
CO (Carbon Monoxide)	0	--
DT-ASCR (Drive Trace Absolute Speed Change Rating)	0.411	--
DT-EER (Drive Trace Energy Economy Rating)	0.221	--
DT-IWRR (Drive Trace Inertia Work Ratio Rating)	0.987	--
MFR FE (Manufacturer Fuel Economy)	46.97	71.7585693
NOX (Nitrogen Oxide)	0	--
N2O (Nitrous Oxide)	0	--
HC-NM (Non-methane Hydrocarbon)	0	--
NMOG (Non-methane organic gases)	0	--

Test Result Name	Unrounded Test Result	Verify Calculated CREE/OPT-CREE
Carbon-Related Exhaust Emissions	0	--
Optional Carbon-Related Exhaust Emissions	0	--

Test Result Name	Unrounded Test Result	Verify Calculated CO2
Carbon dioxide	0	--

Manufacturer Test Comments DC energy consumption = 469.7 Wh/mi

Certification Summary Information Report

Test Group		TWHNV00.0LZB				Evaporative/Refueling Family				--		
Certification Region	Useful Life	Standard Level	Emission Name	Rounded Result	RAF	NMOG/NM HC Ratio	Diesel Adjustment Factor	Add DF	Mult DF	Certification Level	Standard	Pass/Fail
Fed	150,000 miles	Federal Tier 3 Bin 0	CO	0.0	--	--	--	0	--	0	0	Pass

Certification Summary Information Report

Test Group	TWHNV00.0LZB	Evaporative/Refueling Family	--
Test #	SWHN10086725	Test Procedure	77 - Multi-Cycle Test (MCT)
Exhaust Test # for this Evap Test	--	Test Fuel Type	62 - Electricity
Test Date	04/16/2024	Fuel	Electricity
Fuel Batch ID	--	Fuel Calibration Number	--
Vehicle Class	LDV/Passenger Car	DF Type	Mfr. Assigned
Verify Test Lab ID	Applus IDIADA Automotive Technology		
E10 Evaporative Test Measurement Method	--		
Test Start Odometer Reading	7128	Odometer Units	K
4WD Test Dyno	Yes	Diesel Adjustment Factor Usage	--
State of Charge Delta	--		
Drive Cycle Speed Tolerance Criteria	Used Part 1066 (+/- 2.0 mph, +/- 1.0 sec)	Road Speed Fan Usage	Yes
PHEV/EV Charge Depleting Test Information			
Recharge Event Voltage	230	Recharge Event Energy (kiloWatt-hours)	127.924
Charge Depleting Range (Calculated miles)	367.616	Charge Depleting Range (Actual miles)	367.616
Charge Depleting Range Highway (Calculated miles)	360.69	Derived 5-Cycle Coefficient Model Year	--
All Electric Range Unadjusted (miles)	--	Equivalent All Electric Range (miles)	367.616
Number of Charge Depleting Bags/Phases Conducted	8	Transition Bag/Phase Number	--
Charge Depleting Bag/Phase #1			
Test Result/Emission Name		Unrounded Test Result	
Actual Distance Driven (miles)		7.469	
Carbon-Related Exhaust Emissions		0	
Drive Trace Absolute Speed Change Rating		5.856	
Drive Trace Energy Economy Rating		4.44	
Drive Trace Inertia Work Ratio Rating		8.248	
Integrated DC KW-HRS		2.349	
Manufacturer Fuel Economy		31.45	
Charge Depleting Bag/Phase #2			

Certification Summary Information Report

Test Group	TWHNV00.0LZB	Evaporative/Refueling Family	--																
<table border="1"> <thead> <tr> <th>Test Result/Emission Name</th> <th>Unrounded Test Result</th> </tr> </thead> <tbody> <tr> <td>Actual Distance Driven (miles)</td> <td>10.271</td> </tr> <tr> <td>Carbon-Related Exhaust Emissions</td> <td>0</td> </tr> <tr> <td>Drive Trace Absolute Speed Change Rating</td> <td>4.83</td> </tr> <tr> <td>Drive Trace Energy Economy Rating</td> <td>1.767</td> </tr> <tr> <td>Drive Trace Inertia Work Ratio Rating</td> <td>5.267</td> </tr> <tr> <td>Integrated DC KW-HRS</td> <td>3.1565</td> </tr> <tr> <td>Manufacturer Fuel Economy</td> <td>30.73</td> </tr> </tbody> </table>				Test Result/Emission Name	Unrounded Test Result	Actual Distance Driven (miles)	10.271	Carbon-Related Exhaust Emissions	0	Drive Trace Absolute Speed Change Rating	4.83	Drive Trace Energy Economy Rating	1.767	Drive Trace Inertia Work Ratio Rating	5.267	Integrated DC KW-HRS	3.1565	Manufacturer Fuel Economy	30.73
Test Result/Emission Name	Unrounded Test Result																		
Actual Distance Driven (miles)	10.271																		
Carbon-Related Exhaust Emissions	0																		
Drive Trace Absolute Speed Change Rating	4.83																		
Drive Trace Energy Economy Rating	1.767																		
Drive Trace Inertia Work Ratio Rating	5.267																		
Integrated DC KW-HRS	3.1565																		
Manufacturer Fuel Economy	30.73																		
Charge Depleting Bag/Phase #3																			
<table border="1"> <thead> <tr> <th>Test Result/Emission Name</th> <th>Unrounded Test Result</th> </tr> </thead> <tbody> <tr> <td>Actual Distance Driven (miles)</td> <td>7.444</td> </tr> <tr> <td>Carbon-Related Exhaust Emissions</td> <td>0</td> </tr> <tr> <td>Drive Trace Absolute Speed Change Rating</td> <td>3.922</td> </tr> <tr> <td>Drive Trace Energy Economy Rating</td> <td>2.006</td> </tr> <tr> <td>Drive Trace Inertia Work Ratio Rating</td> <td>4.864</td> </tr> <tr> <td>Integrated DC KW-HRS</td> <td>2.2908</td> </tr> <tr> <td>Manufacturer Fuel Economy</td> <td>30.77</td> </tr> </tbody> </table>				Test Result/Emission Name	Unrounded Test Result	Actual Distance Driven (miles)	7.444	Carbon-Related Exhaust Emissions	0	Drive Trace Absolute Speed Change Rating	3.922	Drive Trace Energy Economy Rating	2.006	Drive Trace Inertia Work Ratio Rating	4.864	Integrated DC KW-HRS	2.2908	Manufacturer Fuel Economy	30.77
Test Result/Emission Name	Unrounded Test Result																		
Actual Distance Driven (miles)	7.444																		
Carbon-Related Exhaust Emissions	0																		
Drive Trace Absolute Speed Change Rating	3.922																		
Drive Trace Energy Economy Rating	2.006																		
Drive Trace Inertia Work Ratio Rating	4.864																		
Integrated DC KW-HRS	2.2908																		
Manufacturer Fuel Economy	30.77																		
Charge Depleting Bag/Phase #4																			
<table border="1"> <thead> <tr> <th>Test Result/Emission Name</th> <th>Unrounded Test Result</th> </tr> </thead> <tbody> <tr> <td>Actual Distance Driven (miles)</td> <td>238.513</td> </tr> <tr> <td>Carbon-Related Exhaust Emissions</td> <td>0</td> </tr> <tr> <td>Drive Trace Absolute Speed Change Rating</td> <td>0</td> </tr> <tr> <td>Drive Trace Energy Economy Rating</td> <td>-0.333</td> </tr> <tr> <td>Drive Trace Inertia Work Ratio Rating</td> <td>0</td> </tr> <tr> <td>Integrated DC KW-HRS</td> <td>87.1452</td> </tr> <tr> <td>Manufacturer Fuel Economy</td> <td>36.54</td> </tr> </tbody> </table>				Test Result/Emission Name	Unrounded Test Result	Actual Distance Driven (miles)	238.513	Carbon-Related Exhaust Emissions	0	Drive Trace Absolute Speed Change Rating	0	Drive Trace Energy Economy Rating	-0.333	Drive Trace Inertia Work Ratio Rating	0	Integrated DC KW-HRS	87.1452	Manufacturer Fuel Economy	36.54
Test Result/Emission Name	Unrounded Test Result																		
Actual Distance Driven (miles)	238.513																		
Carbon-Related Exhaust Emissions	0																		
Drive Trace Absolute Speed Change Rating	0																		
Drive Trace Energy Economy Rating	-0.333																		
Drive Trace Inertia Work Ratio Rating	0																		
Integrated DC KW-HRS	87.1452																		
Manufacturer Fuel Economy	36.54																		
Charge Depleting Bag/Phase #5																			
<table border="1"> <thead> <tr> <th>Test Result/Emission Name</th> <th>Unrounded Test Result</th> </tr> </thead> <tbody> <tr> <td>Actual Distance Driven (miles)</td> <td>7.444</td> </tr> <tr> <td>Carbon-Related Exhaust Emissions</td> <td>0</td> </tr> <tr> <td>Drive Trace Absolute Speed Change Rating</td> <td>2.732</td> </tr> <tr> <td>Drive Trace Energy Economy Rating</td> <td>2.913</td> </tr> <tr> <td>Drive Trace Inertia Work Ratio Rating</td> <td>4.379</td> </tr> <tr> <td>Integrated DC KW-HRS</td> <td>2.154</td> </tr> <tr> <td>Manufacturer Fuel Economy</td> <td>28.94</td> </tr> </tbody> </table>				Test Result/Emission Name	Unrounded Test Result	Actual Distance Driven (miles)	7.444	Carbon-Related Exhaust Emissions	0	Drive Trace Absolute Speed Change Rating	2.732	Drive Trace Energy Economy Rating	2.913	Drive Trace Inertia Work Ratio Rating	4.379	Integrated DC KW-HRS	2.154	Manufacturer Fuel Economy	28.94
Test Result/Emission Name	Unrounded Test Result																		
Actual Distance Driven (miles)	7.444																		
Carbon-Related Exhaust Emissions	0																		
Drive Trace Absolute Speed Change Rating	2.732																		
Drive Trace Energy Economy Rating	2.913																		
Drive Trace Inertia Work Ratio Rating	4.379																		
Integrated DC KW-HRS	2.154																		
Manufacturer Fuel Economy	28.94																		
Charge Depleting Bag/Phase #6																			

Certification Summary Information Report

Test Group	TWHNV00.0LZB	Evaporative/Refueling Family	--
-------------------	--------------	------------------------------	----

Test Result/Emission Name	Unrounded Test Result
Actual Distance Driven (miles)	10.265
Carbon-Related Exhaust Emissions	0
Drive Trace Absolute Speed Change Rating	0.024
Drive Trace Energy Economy Rating	1.136
Drive Trace Inertia Work Ratio Rating	-0.175
Integrated DC KW-HRS	3.0819
Manufacturer Fuel Economy	30.02

Charge Depleting Bag/Phase #7

Test Result/Emission Name	Unrounded Test Result
Actual Distance Driven (miles)	7.444
Carbon-Related Exhaust Emissions	0
Drive Trace Absolute Speed Change Rating	4.007
Drive Trace Energy Economy Rating	3.093
Drive Trace Inertia Work Ratio Rating	5.48
Integrated DC KW-HRS	2.2031
Manufacturer Fuel Economy	29.6

Charge Depleting Bag/Phase #8

Test Result/Emission Name	Unrounded Test Result
Actual Distance Driven (miles)	19.182
Carbon-Related Exhaust Emissions	0
Drive Trace Absolute Speed Change Rating	88.51
Drive Trace Energy Economy Rating	-0.817
Drive Trace Inertia Work Ratio Rating	82.78
Integrated DC KW-HRS	7.1865
Manufacturer Fuel Economy	37.46

Manufacturer Test Comments

MCT UBE energy = 109.570 kWh Due to the system only allows metrics between -99.99 to 99.99, '0' are input in the test results. The charge depleting bag/phase #4 real data metrics are: DT-ASCR = 560.772 DT-IWRR = 1115.138

Certification Summary Information Report

Test Group	TWHNV00.0LZB	Evaporative/Refueling Family	--
-------------------	--------------	-------------------------------------	----

Certification Region	Useful Life	Standard Level	Emission Name	Rounded Result	RAF	NMOG/NM HC Ratio	Diesel Adjustment Factor	Add DF	Mult DF	Certification Level	Standard	Pass/Fail
Fed	150,000 miles	Federal Tier 3 Bin 0	CREE	0	--	--	--	0	--	0	--	--
Fed	150,000 miles	Federal Tier 3 Bin 0	CREE	0	--	--	--	0	--	0	--	--
Fed	150,000 miles	Federal Tier 3 Bin 0	CREE	0	--	--	--	0	--	0	--	--
Fed	150,000 miles	Federal Tier 3 Bin 0	CREE	0	--	--	--	0	--	0	--	--
Fed	150,000 miles	Federal Tier 3 Bin 0	CREE	0	--	--	--	0	--	0	--	--
Fed	150,000 miles	Federal Tier 3 Bin 0	CREE	0	--	--	--	0	--	0	--	--
Fed	150,000 miles	Federal Tier 3 Bin 0	CREE	0	--	--	--	0	--	0	--	--
Fed	150,000 miles	Federal Tier 3 Bin 0	CREE	0	--	--	--	0	--	0	--	--

Certification Summary Information Report

Test Group	TWHNV00.0LZB	Evaporative/Refueling Family	--
Test #	SWHN10086824	Test Procedure	86 - Charge Depleting 20 Degree F FTP
Exhaust Test # for this Evap Test	--	Test Fuel Type	62 - Electricity
Test Date	04/30/2024	Fuel	N/A
Fuel Batch ID	--	Fuel Calibration Number	--
Vehicle Class	N/A	DF Type	Mfr. Assigned
Verify Test Lab ID	Applus IDIADA Automotive Technology		
E10 Evaporative Test Measurement Method	--		
Test Start Odometer Reading	7961	Odometer Units	K
4WD Test Dyno	Yes	Diesel Adjustment Factor Usage	--
State of Charge Delta	No		
Drive Cycle Speed Tolerance Criteria	Used Part 1066 (+/- 2.0 mph, +/- 1.0 sec)	Road Speed Fan Usage	Yes
PHEV/EV Charge Depleting Test Information			
Recharge Event Voltage	230	Recharge Event Energy (kiloWatt-hours)	127.924
Charge Depleting Range (Calculated miles)	14.9	Charge Depleting Range (Actual miles)	14.9
Charge Depleting Range Highway (Calculated miles)	--	Derived 5-Cycle Coefficient Model Year	--
All Electric Range Unadjusted (miles)	--	Equivalent All Electric Range (miles)	14.9
Number of Charge Depleting Bags/Phases Conducted	4	Transition Bag/Phase Number	--
Charge Depleting Bag/Phase #1			
Test Result/Emission Name		Unrounded Test Result	
Actual Distance Driven (miles)		3.578	
Carbon-Related Exhaust Emissions		0	
Drive Trace Absolute Speed Change Rating		-0.748	
Drive Trace Energy Economy Rating		-0.355	
Drive Trace Inertia Work Ratio Rating		-1.323	
Integrated DC KW-HRS		2.3063	
Manufacturer Fuel Economy		64.45	
Charge Depleting Bag/Phase #2			

Certification Summary Information Report

Test Group	TWHNV00.0LZB	Evaporative/Refueling Family	--																
<table border="1"> <thead> <tr> <th>Test Result/Emission Name</th> <th>Unrounded Test Result</th> </tr> </thead> <tbody> <tr> <td>Actual Distance Driven (miles)</td> <td>3.839</td> </tr> <tr> <td>Carbon-Related Exhaust Emissions</td> <td>0</td> </tr> <tr> <td>Drive Trace Absolute Speed Change Rating</td> <td>0.416</td> </tr> <tr> <td>Drive Trace Energy Economy Rating</td> <td>-0.669</td> </tr> <tr> <td>Drive Trace Inertia Work Ratio Rating</td> <td>0.315</td> </tr> <tr> <td>Integrated DC KW-HRS</td> <td>1.9775</td> </tr> <tr> <td>Manufacturer Fuel Economy</td> <td>51.52</td> </tr> </tbody> </table>				Test Result/Emission Name	Unrounded Test Result	Actual Distance Driven (miles)	3.839	Carbon-Related Exhaust Emissions	0	Drive Trace Absolute Speed Change Rating	0.416	Drive Trace Energy Economy Rating	-0.669	Drive Trace Inertia Work Ratio Rating	0.315	Integrated DC KW-HRS	1.9775	Manufacturer Fuel Economy	51.52
Test Result/Emission Name	Unrounded Test Result																		
Actual Distance Driven (miles)	3.839																		
Carbon-Related Exhaust Emissions	0																		
Drive Trace Absolute Speed Change Rating	0.416																		
Drive Trace Energy Economy Rating	-0.669																		
Drive Trace Inertia Work Ratio Rating	0.315																		
Integrated DC KW-HRS	1.9775																		
Manufacturer Fuel Economy	51.52																		
Charge Depleting Bag/Phase #3																			
<table border="1"> <thead> <tr> <th>Test Result/Emission Name</th> <th>Unrounded Test Result</th> </tr> </thead> <tbody> <tr> <td>Actual Distance Driven (miles)</td> <td>3.59</td> </tr> <tr> <td>Carbon-Related Exhaust Emissions</td> <td>0</td> </tr> <tr> <td>Drive Trace Absolute Speed Change Rating</td> <td>-0.665</td> </tr> <tr> <td>Drive Trace Energy Economy Rating</td> <td>-0.316</td> </tr> <tr> <td>Drive Trace Inertia Work Ratio Rating</td> <td>-0.71</td> </tr> <tr> <td>Integrated DC KW-HRS</td> <td>1.8024</td> </tr> <tr> <td>Manufacturer Fuel Economy</td> <td>50.2</td> </tr> </tbody> </table>				Test Result/Emission Name	Unrounded Test Result	Actual Distance Driven (miles)	3.59	Carbon-Related Exhaust Emissions	0	Drive Trace Absolute Speed Change Rating	-0.665	Drive Trace Energy Economy Rating	-0.316	Drive Trace Inertia Work Ratio Rating	-0.71	Integrated DC KW-HRS	1.8024	Manufacturer Fuel Economy	50.2
Test Result/Emission Name	Unrounded Test Result																		
Actual Distance Driven (miles)	3.59																		
Carbon-Related Exhaust Emissions	0																		
Drive Trace Absolute Speed Change Rating	-0.665																		
Drive Trace Energy Economy Rating	-0.316																		
Drive Trace Inertia Work Ratio Rating	-0.71																		
Integrated DC KW-HRS	1.8024																		
Manufacturer Fuel Economy	50.2																		
Charge Depleting Bag/Phase #4																			
<table border="1"> <thead> <tr> <th>Test Result/Emission Name</th> <th>Unrounded Test Result</th> </tr> </thead> <tbody> <tr> <td>Actual Distance Driven (miles)</td> <td>3.861</td> </tr> <tr> <td>Carbon-Related Exhaust Emissions</td> <td>0</td> </tr> <tr> <td>Drive Trace Absolute Speed Change Rating</td> <td>0.41</td> </tr> <tr> <td>Drive Trace Energy Economy Rating</td> <td>-0.312</td> </tr> <tr> <td>Drive Trace Inertia Work Ratio Rating</td> <td>0.911</td> </tr> <tr> <td>Integrated DC KW-HRS</td> <td>1.7188</td> </tr> <tr> <td>Manufacturer Fuel Economy</td> <td>44.52</td> </tr> </tbody> </table>				Test Result/Emission Name	Unrounded Test Result	Actual Distance Driven (miles)	3.861	Carbon-Related Exhaust Emissions	0	Drive Trace Absolute Speed Change Rating	0.41	Drive Trace Energy Economy Rating	-0.312	Drive Trace Inertia Work Ratio Rating	0.911	Integrated DC KW-HRS	1.7188	Manufacturer Fuel Economy	44.52
Test Result/Emission Name	Unrounded Test Result																		
Actual Distance Driven (miles)	3.861																		
Carbon-Related Exhaust Emissions	0																		
Drive Trace Absolute Speed Change Rating	0.41																		
Drive Trace Energy Economy Rating	-0.312																		
Drive Trace Inertia Work Ratio Rating	0.911																		
Integrated DC KW-HRS	1.7188																		
Manufacturer Fuel Economy	44.52																		
Manufacturer Test Comments	2xUDDS 20F test +MY25 requirement. DC energy consumption Phase 1 = 644.5 Wh/mi; Phase 2 = 515.2 Wh/mi; Phase 3 = 502.0 Wh/mi; Phase 4 = 445.2 Wh/mi																		

Certification Summary Information Report

Test Group	TWHNV00.0LZB	Evaporative/Refueling Family	--
-------------------	--------------	-------------------------------------	----

Dynamometer Coefficients:

Coefficient Category	Target Coefficients			Set Coefficients			EPA Calculated Total Road Load Horse Power for City/Highway/Evap Coefficients
	A (lbf)	B (lbf/mph)	C (lbf/mph**2)	A (lbf)	B (lbf/mph)	C (lbf/mph**2)	
City/Highway/Evap	52.54	0.0264	0.023	-9.08	-0.0365	0.022	14.8
Cold CO	57.79	0.0289	0.0253	-30.78	-0.2927	0.0253	N/A
US06	52.54	0.0264	0.023	-9.08	-0.0365	0.022	N/A

Emission Control Device Comments

--

Manufacturer Test Vehicle Comments

This is 2025 ELETRE R Long Range; Front Motor Power - 225kW (EDS1 motor); Rear Motor Power - 450 kW (Zeus motor) Number of transmission gears on front motor EDS1: 1 Number of transmission gears on rear motor Zeus: 2 N/V ratio on front motor EDS1: 9.187 N/V ratio on rear motor Zeus: 1st 13.645 , 2nd 7.155

Certification Summary Information Report

Test Group	TWHNV00.0LZB	Evaporative/Refueling Family	--
Test #	SWHN10086780	Test Procedure	2 - CVS 75 and later (w/o can. load)
Exhaust Test # for this Evap Test	--	Test Fuel Type	62 - Electricity
Test Date	04/19/2024	Fuel	Electricity
Fuel Batch ID	--	Fuel Calibration Number	--
Vehicle Class	LDV/Passenger Car	DF Type	Mfr. Assigned
Verify Test Lab ID	Applus IDIADA Automotive Technology		
E10 Evaporative Test Measurement Method	--		
Test Start Odometer Reading	9423	Odometer Units	K
4WD Test Dyno	Yes	Diesel Adjustment Factor Usage	--
State of Charge Delta	No	Road Speed Fan Usage	Yes
Drive Cycle Speed Tolerance Criteria	Used Part 1066 (+/- 2.0 mph, +/- 1.0 sec)		

Test Results

Test Result Name	Unrounded Test Result	Verify Calculated FE Equivalent Value (kilowatt-hour per 100 miles)
ACT-DISTANCE (Actual Distance Driven (miles))	14.88	--
METHANE (CH4 - Methane)	0	--
CO (Carbon Monoxide)	0	--
DT-ASCR (Drive Trace Absolute Speed Change Rating)	0	--
DT-EER (Drive Trace Energy Economy Rating)	0	--
DT-IWRR (Drive Trace Inertia Work Ratio Rating)	0	--
MFR FE (Manufacturer Fuel Economy)	29.66	113.6378962
NOX (Nitrogen Oxide)	0	--
N2O (Nitrous Oxide)	0	--
HC-NM (Non-methane Hydrocarbon)	0	--
NMOG (Non-methane organic gases)	0	--

Test Result Name	Unrounded Test Result	Verify Calculated CREE/OPT-CREE
Carbon-Related Exhaust Emissions	0	0
Optional Carbon-Related Exhaust Emissions	0	0

Test Result Name	Unrounded Test Result	Verify Calculated CO2
Carbon dioxide	0	--

Manufacturer Test Comments

DC energy consumption Phase1 = 316.5 Wh/mi; Phase2 = 286.3 Wh/mi; Phase3 = 305.8 Wh/mi; Phase4 = 281.9 Wh/mi Drive trace indicators Ph1 ASCR (%) = -1.705; EER (%) = -0.366; IWR (%) = -2.733 Ph2 ASCR (%) = 0.722; EER (%) = 0.550; IWR (%) = 1.303 Ph3 ASCR (%) = -0.868; EER (%) = -0.639; IWR (%) = -1.073 Ph4 ASCR (%) = -0.876; EER (%) = -1.133; IWR (%) = -0.902

Certification Summary Information Report

Test Group	TWHNV00.0LZB	Evaporative/Refueling Family	--
-------------------	--------------	-------------------------------------	----

Certification Region	Useful Life	Standard Level	Emission Name	Rounded Result	RAF	NMOG/NM HC Ratio	Diesel Adjustment Factor	Add DF	Mult DF	Certification Level	Standard	Pass/Fail
Fed	150,000 miles	Federal Tier 3 Bin 0	CO	0.0	--	--	--	0	--	0	0	Pass
Fed	150,000 miles	Federal Tier 3 Bin 0	CREE	0	--	--	--	0	--	0	--	--

NOTE: For Non-charge depleting tests, the Rounded Result for CREE/OPT-CREE Emission names are Verify-calculated values.

Certification Summary Information Report

Test Group	TWHNV00.0LZB	Evaporative/Refueling Family	--
Test #	SWHN10086803	Test Procedure	3 - HWFE
Exhaust Test # for this Evap Test	--	Test Fuel Type	62 - Electricity
Test Date	04/19/2024	Fuel	Electricity
Fuel Batch ID	--	Fuel Calibration Number	--
Vehicle Class	LDV/Passenger Car	DF Type	Mfr. Assigned
Verify Test Lab ID	Applus IDIADA Automotive Technology		
E10 Evaporative Test Measurement Method	--		
Test Start Odometer Reading	9423	Odometer Units	K
4WD Test Dyno	Yes	Diesel Adjustment Factor Usage	--
State of Charge Delta	No		
Drive Cycle Speed Tolerance Criteria	Used Part 1066 (+/- 2.0 mph, +/- 1.0 sec)	Road Speed Fan Usage	Yes

Test Results

Test Result Name	Unrounded Test Result	Verify Calculated FE Equivalent Value (kilowatt-hour per 100 miles)
ACT-DISTANCE (Actual Distance Driven (miles))	10.246	--
METHANE (CH4 - Methane)	0	--
CO (Carbon Monoxide)	0	--
DT-ASCR (Drive Trace Absolute Speed Change Rating)	-0.673	--
DT-EER (Drive Trace Energy Economy Rating)	0.243	--
DT-IWRR (Drive Trace Inertia Work Ratio Rating)	-0.857	--
MFR FE (Manufacturer Fuel Economy)	29.82	113.028169
NOX (Nitrogen Oxide)	0	--
N2O (Nitrous Oxide)	0	--
HC-NM (Non-methane Hydrocarbon)	0	--
NMOG (Non-methane organic gases)	0	--

Test Result Name	Unrounded Test Result	Verify Calculated CREE/OPT-CREE
Carbon-Related Exhaust Emissions	0	0
Optional Carbon-Related Exhaust Emissions	0	0

Test Result Name	Unrounded Test Result	Verify Calculated CO2
Carbon dioxide	0	--

Manufacturer Test Comments

DC energy consumption = 298.2 Wh/mi

Certification Summary Information Report

Test Group		TWHNV00.0LZB				Evaporative/Refueling Family				--		
Certification Region	Useful Life	Standard Level	Emission Name	Rounded Result	RAF	NMOG/NM HC Ratio	Diesel Adjustment Factor	Add DF	Mult DF	Certification Level	Standard	Pass/Fail
Fed	150,000 miles	Federal Tier 3 Bin 0	CO	0.0	--	--	--	0	--	0	0	Pass
Fed	150,000 miles	Federal Tier 3 Bin 0	CREE	0	--	--	--	0	--	0	--	--

NOTE: For Non-charge depleting tests, the Rounded Result for CREE/OPT-CREE Emission names are Verify-calculated values.

Certification Summary Information Report

Test Group	TWHNV00.0LZB	Evaporative/Refueling Family	--
Test #	SWHN10086807	Test Procedure	90 - US06
Exhaust Test # for this Evap Test	--	Test Fuel Type	62 - Electricity
Test Date	04/19/2024	Fuel	Electricity
Fuel Batch ID	--	Fuel Calibration Number	--
Vehicle Class	LDV/Passenger Car	DF Type	Mfr. Assigned
Verify Test Lab ID	Applus IDIADA Automotive Technology		
E10 Evaporative Test Measurement Method	--		
Test Start Odometer Reading	9423	Odometer Units	K
4WD Test Dyno	Yes	Diesel Adjustment Factor Usage	--
State of Charge Delta	No		
Drive Cycle Speed Tolerance Criteria	Used Part 1066 (+/- 2.0 mph, +/- 1.0 sec)	Road Speed Fan Usage	Yes

Test Results

Test Result Name	Unrounded Test Result	Verify Calculated FE Equivalent Value (kilowatt-hour per 100 miles)
ACT-DISTANCE (Actual Distance Driven (miles))	7.973	--
METHANE (CH4 - Methane)	0	--
CO (Carbon Monoxide)	0	--
DT-ASCR (Drive Trace Absolute Speed Change Rating)	0	--
DT-EER (Drive Trace Energy Economy Rating)	0	--
DT-IWRR (Drive Trace Inertia Work Ratio Rating)	0	--
MFR FE (Manufacturer Fuel Economy)	38.29	88.0255941
NOX (Nitrogen Oxide)	0	--
N2O (Nitrous Oxide)	0	--
HC-NM (Non-methane Hydrocarbon)	0	--
NMOG (Non-methane organic gases)	0	--

Test Result Name	Unrounded Test Result	Verify Calculated CREE/OPT-CREE
Carbon-Related Exhaust Emissions	0	--
Optional Carbon-Related Exhaust Emissions	0	--

Test Result Name	Unrounded Test Result	Verify Calculated CO2
Carbon dioxide	0	--

Manufacturer Test Comments

DC energy consumption Phase 1 (Highway) = 412.5 Wh/mi; Phase 2 (City) = 374.6 Wh/mi Drive trace indicators Ph city ASCR (%) = -2.169; EER (%) = -0.163; IWR (%) = -2.055 Ph hw ASCR (%) = -2.612; EER (%) = -3.261; IWR (%) = -3.331

Certification Summary Information Report

Test Group		TWHNV00.0LZB				Evaporative/Refueling Family				--		
Certification Region	Useful Life	Standard Level	Emission Name	Rounded Result	RAF	NMOG/NM HC Ratio	Diesel Adjustment Factor	Add DF	Mult DF	Certification Level	Standard	Pass/Fail
Fed	150,000 miles	Federal Tier 3 Bin 0	CO	0.0	--	--	--	0	--	0	0	Pass

Certification Summary Information Report

Test Group	TWHNV00.0LZB	Evaporative/Refueling Family	--
Test #	SWHN10086819	Test Procedure	95 - SC03
Exhaust Test # for this Evap Test	--	Test Fuel Type	62 - Electricity
Test Date	04/24/2024	Fuel	Electricity
Fuel Batch ID	--	Fuel Calibration Number	--
Vehicle Class	LDV/Passenger Car	DF Type	Mfr. Assigned
Verify Test Lab ID	Applus IDIADA Automotive Technology		
E10 Evaporative Test Measurement Method	--		
Test Start Odometer Reading	9589	Odometer Units	K
4WD Test Dyno	Yes	Diesel Adjustment Factor Usage	--
State of Charge Delta	No		
Drive Cycle Speed Tolerance Criteria	Used Part 1066 (+/- 2.0 mph, +/- 1.0 sec)	Road Speed Fan Usage	Yes

Test Results

Test Result Name	Unrounded Test Result	Verify Calculated FE Equivalent Value (kilowatt-hour per 100 miles)
ACT-DISTANCE (Actual Distance Driven (miles))	3.568	--
METHANE (CH4 - Methane)	0	--
CO (Carbon Monoxide)	0	--
DT-ASCR (Drive Trace Absolute Speed Change Rating)	1.077	--
DT-EER (Drive Trace Energy Economy Rating)	1.877	--
DT-IWRR (Drive Trace Inertia Work Ratio Rating)	2.495	--
MFR FE (Manufacturer Fuel Economy)	43.62	77.2696011
NOX (Nitrogen Oxide)	0	--
N2O (Nitrous Oxide)	0	--
HC-NM (Non-methane Hydrocarbon)	0	--
NMOG (Non-methane organic gases)	0	--

Test Result Name	Unrounded Test Result	Verify Calculated CREE/OPT-CREE
Carbon-Related Exhaust Emissions	0	--
Optional Carbon-Related Exhaust Emissions	0	--

Test Result Name	Unrounded Test Result	Verify Calculated CO2
Carbon dioxide	0	--

Manufacturer Test Comments

DC energy consumption = 436.2 Wh/mi

Certification Summary Information Report

Test Group	TWHNV00.0LZB	Evaporative/Refueling Family	--
-------------------	--------------	-------------------------------------	----

Certification Region	Useful Life	Standard Level	Emission Name	Rounded Result	RAF	NMOG/NM HC Ratio	Diesel Adjustment Factor	Add DF	Mult DF	Certification Level	Standard	Pass/Fail
Fed	150,000 miles	Federal Tier 3 Bin 0	CO	0.0	--	--	--	0	--	0	0	Pass

Certification Summary Information Report

Test Group	TWHNV00.0LZB	Evaporative/Refueling Family	--
Test #	SWHN10086682	Test Procedure	77 - Multi-Cycle Test (MCT)
Exhaust Test # for this Evap Test	--	Test Fuel Type	62 - Electricity
Test Date	04/11/2024	Fuel	Electricity
Fuel Batch ID	--	Fuel Calibration Number	--
Vehicle Class	LDV/Passenger Car	DF Type	Mfr. Assigned
Verify Test Lab ID	Applus IDIADA Automotive Technology		
E10 Evaporative Test Measurement Method	--		
Test Start Odometer Reading	8816	Odometer Units	K
4WD Test Dyno	Yes	Diesel Adjustment Factor Usage	--
State of Charge Delta	--		
Drive Cycle Speed Tolerance Criteria	Used Part 1066 (+/- 2.0 mph, +/- 1.0 sec)	Road Speed Fan Usage	Yes
PHEV/EV Charge Depleting Test Information			
Recharge Event Voltage	230	Recharge Event Energy (kiloWatt-hours)	128.301
Charge Depleting Range (Calculated miles)	383.559	Charge Depleting Range (Actual miles)	383.559
Charge Depleting Range Highway (Calculated miles)	373.593	Derived 5-Cycle Coefficient Model Year	--
All Electric Range Unadjusted (miles)	--	Equivalent All Electric Range (miles)	383.559
Number of Charge Depleting Bags/Phases Conducted	8	Transition Bag/Phase Number	--
Charge Depleting Bag/Phase #1			
Test Result/Emission Name		Unrounded Test Result	
Actual Distance Driven (miles)		7.413	
Carbon-Related Exhaust Emissions		0	
Drive Trace Absolute Speed Change Rating		-0.99	
Drive Trace Energy Economy Rating		-1.119	
Drive Trace Inertia Work Ratio Rating		-2.609	
Integrated DC KW-HRS		2.2834	
Manufacturer Fuel Economy		30.8	
Charge Depleting Bag/Phase #2			

Certification Summary Information Report

Test Group	TWHNV00.0LZB	Evaporative/Refueling Family	--																
<table border="1"> <thead> <tr> <th>Test Result/Emission Name</th> <th>Unrounded Test Result</th> </tr> </thead> <tbody> <tr> <td>Actual Distance Driven (miles)</td> <td>10.253</td> </tr> <tr> <td>Carbon-Related Exhaust Emissions</td> <td>0</td> </tr> <tr> <td>Drive Trace Absolute Speed Change Rating</td> <td>-3.352</td> </tr> <tr> <td>Drive Trace Energy Economy Rating</td> <td>-0.331</td> </tr> <tr> <td>Drive Trace Inertia Work Ratio Rating</td> <td>-4.849</td> </tr> <tr> <td>Integrated DC KW-HRS</td> <td>3.0852</td> </tr> <tr> <td>Manufacturer Fuel Economy</td> <td>30.09</td> </tr> </tbody> </table>				Test Result/Emission Name	Unrounded Test Result	Actual Distance Driven (miles)	10.253	Carbon-Related Exhaust Emissions	0	Drive Trace Absolute Speed Change Rating	-3.352	Drive Trace Energy Economy Rating	-0.331	Drive Trace Inertia Work Ratio Rating	-4.849	Integrated DC KW-HRS	3.0852	Manufacturer Fuel Economy	30.09
Test Result/Emission Name	Unrounded Test Result																		
Actual Distance Driven (miles)	10.253																		
Carbon-Related Exhaust Emissions	0																		
Drive Trace Absolute Speed Change Rating	-3.352																		
Drive Trace Energy Economy Rating	-0.331																		
Drive Trace Inertia Work Ratio Rating	-4.849																		
Integrated DC KW-HRS	3.0852																		
Manufacturer Fuel Economy	30.09																		
Charge Depleting Bag/Phase #3																			
<table border="1"> <thead> <tr> <th>Test Result/Emission Name</th> <th>Unrounded Test Result</th> </tr> </thead> <tbody> <tr> <td>Actual Distance Driven (miles)</td> <td>7.419</td> </tr> <tr> <td>Carbon-Related Exhaust Emissions</td> <td>0</td> </tr> <tr> <td>Drive Trace Absolute Speed Change Rating</td> <td>-0.47</td> </tr> <tr> <td>Drive Trace Energy Economy Rating</td> <td>-0.29</td> </tr> <tr> <td>Drive Trace Inertia Work Ratio Rating</td> <td>-0.842</td> </tr> <tr> <td>Integrated DC KW-HRS</td> <td>2.2095</td> </tr> <tr> <td>Manufacturer Fuel Economy</td> <td>29.78</td> </tr> </tbody> </table>				Test Result/Emission Name	Unrounded Test Result	Actual Distance Driven (miles)	7.419	Carbon-Related Exhaust Emissions	0	Drive Trace Absolute Speed Change Rating	-0.47	Drive Trace Energy Economy Rating	-0.29	Drive Trace Inertia Work Ratio Rating	-0.842	Integrated DC KW-HRS	2.2095	Manufacturer Fuel Economy	29.78
Test Result/Emission Name	Unrounded Test Result																		
Actual Distance Driven (miles)	7.419																		
Carbon-Related Exhaust Emissions	0																		
Drive Trace Absolute Speed Change Rating	-0.47																		
Drive Trace Energy Economy Rating	-0.29																		
Drive Trace Inertia Work Ratio Rating	-0.842																		
Integrated DC KW-HRS	2.2095																		
Manufacturer Fuel Economy	29.78																		
Charge Depleting Bag/Phase #4																			
<table border="1"> <thead> <tr> <th>Test Result/Emission Name</th> <th>Unrounded Test Result</th> </tr> </thead> <tbody> <tr> <td>Actual Distance Driven (miles)</td> <td>242.926</td> </tr> <tr> <td>Carbon-Related Exhaust Emissions</td> <td>0</td> </tr> <tr> <td>Drive Trace Absolute Speed Change Rating</td> <td>0</td> </tr> <tr> <td>Drive Trace Energy Economy Rating</td> <td>-0.204</td> </tr> <tr> <td>Drive Trace Inertia Work Ratio Rating</td> <td>0</td> </tr> <tr> <td>Integrated DC KW-HRS</td> <td>87.4922</td> </tr> <tr> <td>Manufacturer Fuel Economy</td> <td>36.02</td> </tr> </tbody> </table>				Test Result/Emission Name	Unrounded Test Result	Actual Distance Driven (miles)	242.926	Carbon-Related Exhaust Emissions	0	Drive Trace Absolute Speed Change Rating	0	Drive Trace Energy Economy Rating	-0.204	Drive Trace Inertia Work Ratio Rating	0	Integrated DC KW-HRS	87.4922	Manufacturer Fuel Economy	36.02
Test Result/Emission Name	Unrounded Test Result																		
Actual Distance Driven (miles)	242.926																		
Carbon-Related Exhaust Emissions	0																		
Drive Trace Absolute Speed Change Rating	0																		
Drive Trace Energy Economy Rating	-0.204																		
Drive Trace Inertia Work Ratio Rating	0																		
Integrated DC KW-HRS	87.4922																		
Manufacturer Fuel Economy	36.02																		
Charge Depleting Bag/Phase #5																			
<table border="1"> <thead> <tr> <th>Test Result/Emission Name</th> <th>Unrounded Test Result</th> </tr> </thead> <tbody> <tr> <td>Actual Distance Driven (miles)</td> <td>7.407</td> </tr> <tr> <td>Carbon-Related Exhaust Emissions</td> <td>0</td> </tr> <tr> <td>Drive Trace Absolute Speed Change Rating</td> <td>-0.187</td> </tr> <tr> <td>Drive Trace Energy Economy Rating</td> <td>-0.471</td> </tr> <tr> <td>Drive Trace Inertia Work Ratio Rating</td> <td>-0.315</td> </tr> <tr> <td>Integrated DC KW-HRS</td> <td>2.0386</td> </tr> <tr> <td>Manufacturer Fuel Economy</td> <td>27.52</td> </tr> </tbody> </table>				Test Result/Emission Name	Unrounded Test Result	Actual Distance Driven (miles)	7.407	Carbon-Related Exhaust Emissions	0	Drive Trace Absolute Speed Change Rating	-0.187	Drive Trace Energy Economy Rating	-0.471	Drive Trace Inertia Work Ratio Rating	-0.315	Integrated DC KW-HRS	2.0386	Manufacturer Fuel Economy	27.52
Test Result/Emission Name	Unrounded Test Result																		
Actual Distance Driven (miles)	7.407																		
Carbon-Related Exhaust Emissions	0																		
Drive Trace Absolute Speed Change Rating	-0.187																		
Drive Trace Energy Economy Rating	-0.471																		
Drive Trace Inertia Work Ratio Rating	-0.315																		
Integrated DC KW-HRS	2.0386																		
Manufacturer Fuel Economy	27.52																		
Charge Depleting Bag/Phase #6																			

Certification Summary Information Report

Test Group	TWHNV00.0LZB	Evaporative/Refueling Family	--
-------------------	--------------	------------------------------	----

Test Result/Emission Name	Unrounded Test Result
Actual Distance Driven (miles)	10.253
Carbon-Related Exhaust Emissions	0
Drive Trace Absolute Speed Change Rating	-2.303
Drive Trace Energy Economy Rating	0.038
Drive Trace Inertia Work Ratio Rating	-3.108
Integrated DC KW-HRS	2.9631
Manufacturer Fuel Economy	28.9

Charge Depleting Bag/Phase #7

Test Result/Emission Name	Unrounded Test Result
Actual Distance Driven (miles)	7.413
Carbon-Related Exhaust Emissions	0
Drive Trace Absolute Speed Change Rating	-0.391
Drive Trace Energy Economy Rating	-1.321
Drive Trace Inertia Work Ratio Rating	-0.55
Integrated DC KW-HRS	2.1314
Manufacturer Fuel Economy	28.75

Charge Depleting Bag/Phase #8

Test Result/Emission Name	Unrounded Test Result
Actual Distance Driven (miles)	21.972
Carbon-Related Exhaust Emissions	0
Drive Trace Absolute Speed Change Rating	47.694
Drive Trace Energy Economy Rating	-1.015
Drive Trace Inertia Work Ratio Rating	21.518
Integrated DC KW-HRS	7.9925
Manufacturer Fuel Economy	36.38

Manufacturer Test Comments

MCT UBE energy = 110.195 kWh Due to the system only allows metrics between -99.99 to 99.99, '0' are input in the test results. The charge depleting bag/phase #4 real data metrics are: DT-ASCR = 479.091 DT-IWRR = 956.074

Certification Summary Information Report

Test Group		TWHNV00.0LZB				Evaporative/Refueling Family				--		
Certification Region	Useful Life	Standard Level	Emission Name	Rounded Result	RAF	NMOG/NM HC Ratio	Diesel Adjustment Factor	Add DF	Mult DF	Certification Level	Standard	Pass/Fail
Fed	150,000 miles	Federal Tier 3 Bin 0	CREE	0	--	--	--	0	--	0	--	--
Fed	150,000 miles	Federal Tier 3 Bin 0	CREE	0	--	--	--	0	--	0	--	--
Fed	150,000 miles	Federal Tier 3 Bin 0	CREE	0	--	--	--	0	--	0	--	--
Fed	150,000 miles	Federal Tier 3 Bin 0	CREE	0	--	--	--	0	--	0	--	--
Fed	150,000 miles	Federal Tier 3 Bin 0	CREE	0	--	--	--	0	--	0	--	--
Fed	150,000 miles	Federal Tier 3 Bin 0	CREE	0	--	--	--	0	--	0	--	--
Fed	150,000 miles	Federal Tier 3 Bin 0	CREE	0	--	--	--	0	--	0	--	--
Fed	150,000 miles	Federal Tier 3 Bin 0	CREE	0	--	--	--	0	--	0	--	--

Certification Summary Information Report

Test Group	TWHNV00.0LZB	Evaporative/Refueling Family	--
Test #	SWHN10086823	Test Procedure	86 - Charge Depleting 20 Degree F FTP
Exhaust Test # for this Evap Test	--	Test Fuel Type	62 - Electricity
Test Date	04/23/2024	Fuel	N/A
Fuel Batch ID	--	Fuel Calibration Number	--
Vehicle Class	N/A	DF Type	Mfr. Assigned
Verify Test Lab ID	Applus IDIADA Automotive Technology		
E10 Evaporative Test Measurement Method	--		
Test Start Odometer Reading	9523	Odometer Units	K
4WD Test Dyno	Yes	Diesel Adjustment Factor Usage	--
State of Charge Delta	No		
Drive Cycle Speed Tolerance Criteria	Used Part 1066 (+/- 2.0 mph, +/- 1.0 sec)	Road Speed Fan Usage	Yes
PHEV/EV Charge Depleting Test Information			
Recharge Event Voltage	230	Recharge Event Energy (kiloWatt-hours)	128.301
Charge Depleting Range (Calculated miles)	14.9	Charge Depleting Range (Actual miles)	14.9
Charge Depleting Range Highway (Calculated miles)	--	Derived 5-Cycle Coefficient Model Year	--
All Electric Range Unadjusted (miles)	--	Equivalent All Electric Range (miles)	14.9
Number of Charge Depleting Bags/Phases Conducted	4	Transition Bag/Phase Number	--
Charge Depleting Bag/Phase #1			
Test Result/Emission Name		Unrounded Test Result	
Actual Distance Driven (miles)		3.595	
Carbon-Related Exhaust Emissions		0	
Drive Trace Absolute Speed Change Rating		-1.73	
Drive Trace Energy Economy Rating		-1.372	
Drive Trace Inertia Work Ratio Rating		-2.117	
Integrated DC KW-HRS		2.413	
Manufacturer Fuel Economy		67.13	
Charge Depleting Bag/Phase #2			

Certification Summary Information Report

Test Group	TWHNV00.0LZB	Evaporative/Refueling Family	--																
<table border="1"> <thead> <tr> <th>Test Result/Emission Name</th> <th>Unrounded Test Result</th> </tr> </thead> <tbody> <tr> <td>Actual Distance Driven (miles)</td> <td>3.844</td> </tr> <tr> <td>Carbon-Related Exhaust Emissions</td> <td>0</td> </tr> <tr> <td>Drive Trace Absolute Speed Change Rating</td> <td>-0.614</td> </tr> <tr> <td>Drive Trace Energy Economy Rating</td> <td>-1.54</td> </tr> <tr> <td>Drive Trace Inertia Work Ratio Rating</td> <td>-0.517</td> </tr> <tr> <td>Integrated DC KW-HRS</td> <td>2.0847</td> </tr> <tr> <td>Manufacturer Fuel Economy</td> <td>54.24</td> </tr> </tbody> </table>				Test Result/Emission Name	Unrounded Test Result	Actual Distance Driven (miles)	3.844	Carbon-Related Exhaust Emissions	0	Drive Trace Absolute Speed Change Rating	-0.614	Drive Trace Energy Economy Rating	-1.54	Drive Trace Inertia Work Ratio Rating	-0.517	Integrated DC KW-HRS	2.0847	Manufacturer Fuel Economy	54.24
Test Result/Emission Name	Unrounded Test Result																		
Actual Distance Driven (miles)	3.844																		
Carbon-Related Exhaust Emissions	0																		
Drive Trace Absolute Speed Change Rating	-0.614																		
Drive Trace Energy Economy Rating	-1.54																		
Drive Trace Inertia Work Ratio Rating	-0.517																		
Integrated DC KW-HRS	2.0847																		
Manufacturer Fuel Economy	54.24																		
Charge Depleting Bag/Phase #3																			
<table border="1"> <thead> <tr> <th>Test Result/Emission Name</th> <th>Unrounded Test Result</th> </tr> </thead> <tbody> <tr> <td>Actual Distance Driven (miles)</td> <td>3.585</td> </tr> <tr> <td>Carbon-Related Exhaust Emissions</td> <td>0</td> </tr> <tr> <td>Drive Trace Absolute Speed Change Rating</td> <td>-1.024</td> </tr> <tr> <td>Drive Trace Energy Economy Rating</td> <td>-0.794</td> </tr> <tr> <td>Drive Trace Inertia Work Ratio Rating</td> <td>-1.5</td> </tr> <tr> <td>Integrated DC KW-HRS</td> <td>1.876</td> </tr> <tr> <td>Manufacturer Fuel Economy</td> <td>52.33</td> </tr> </tbody> </table>				Test Result/Emission Name	Unrounded Test Result	Actual Distance Driven (miles)	3.585	Carbon-Related Exhaust Emissions	0	Drive Trace Absolute Speed Change Rating	-1.024	Drive Trace Energy Economy Rating	-0.794	Drive Trace Inertia Work Ratio Rating	-1.5	Integrated DC KW-HRS	1.876	Manufacturer Fuel Economy	52.33
Test Result/Emission Name	Unrounded Test Result																		
Actual Distance Driven (miles)	3.585																		
Carbon-Related Exhaust Emissions	0																		
Drive Trace Absolute Speed Change Rating	-1.024																		
Drive Trace Energy Economy Rating	-0.794																		
Drive Trace Inertia Work Ratio Rating	-1.5																		
Integrated DC KW-HRS	1.876																		
Manufacturer Fuel Economy	52.33																		
Charge Depleting Bag/Phase #4																			
<table border="1"> <thead> <tr> <th>Test Result/Emission Name</th> <th>Unrounded Test Result</th> </tr> </thead> <tbody> <tr> <td>Actual Distance Driven (miles)</td> <td>3.858</td> </tr> <tr> <td>Carbon-Related Exhaust Emissions</td> <td>0</td> </tr> <tr> <td>Drive Trace Absolute Speed Change Rating</td> <td>-1.429</td> </tr> <tr> <td>Drive Trace Energy Economy Rating</td> <td>-2.08</td> </tr> <tr> <td>Drive Trace Inertia Work Ratio Rating</td> <td>-1.942</td> </tr> <tr> <td>Integrated DC KW-HRS</td> <td>1.8382</td> </tr> <tr> <td>Manufacturer Fuel Economy</td> <td>47.65</td> </tr> </tbody> </table>				Test Result/Emission Name	Unrounded Test Result	Actual Distance Driven (miles)	3.858	Carbon-Related Exhaust Emissions	0	Drive Trace Absolute Speed Change Rating	-1.429	Drive Trace Energy Economy Rating	-2.08	Drive Trace Inertia Work Ratio Rating	-1.942	Integrated DC KW-HRS	1.8382	Manufacturer Fuel Economy	47.65
Test Result/Emission Name	Unrounded Test Result																		
Actual Distance Driven (miles)	3.858																		
Carbon-Related Exhaust Emissions	0																		
Drive Trace Absolute Speed Change Rating	-1.429																		
Drive Trace Energy Economy Rating	-2.08																		
Drive Trace Inertia Work Ratio Rating	-1.942																		
Integrated DC KW-HRS	1.8382																		
Manufacturer Fuel Economy	47.65																		
Manufacturer Test Comments	2xUDDS 20F test +MY25 requirement. DC energy consumption Phase 1 = 671.3 Wh/mi; Phase 2 = 542.4 Wh/mi; Phase 3 = 523.3 Wh/mi; Phase 4 = 476.5 Wh/mi																		
Fuel Properties																			

Certification Summary Information Report

Test Group	TWHNV00.0LZB	Evaporative/Refueling Family	--						
Consolidated List of Standards									
Exhaust Standards									
Cert Region	California + CAA Section 177 states	Cert/In-Use Code	Cert						
Vehicle Class	LDV/Passenger Car	Standard Level	California ZEV						
Fuel	Electricity	Test Procedure	Charge Depleting 20 Degree F FTP						
Useful Life	Emission Name	Rounded Result	RAF	NMOG / NMHC	Upward Diesel Adjustment Factor	Downward Diesel Adjustment Factor	Mult DF	Add DF	Std
150,000 miles	CO	--	--	--	--	--	--	0	0
150,000 miles	CREE	--	--	--	--	--	--	0	0
Cert Region	Federal	Cert/In-Use Code	Cert						
Vehicle Class	LDV/Passenger Car	Standard Level	Federal Tier 3 Bin 0						
Fuel	Electricity	Test Procedure	US06						
Useful Life	Emission Name	Rounded Result	RAF	NMOG / NMHC	Upward Diesel Adjustment Factor	Downward Diesel Adjustment Factor	Mult DF	Add DF	Std
150,000 miles	CO	--	--	--	--	--	--	0	0
150,000 miles	CREE	--	--	--	--	--	--	0	0
Cert Region	Federal	Cert/In-Use Code	Cert						
Vehicle Class	LDV/Passenger Car	Standard Level	Federal Tier 3 Bin 0						
Fuel	Electricity	Test Procedure	CVS 75 and later (w/o can. load)						
Useful Life	Emission Name	Rounded Result	RAF	NMOG / NMHC	Upward Diesel Adjustment Factor	Downward Diesel Adjustment Factor	Mult DF	Add DF	Std
150,000 miles	CO	--	--	--	--	--	--	0	0
150,000 miles	CREE	--	--	--	--	--	--	0	0
Cert Region	Federal	Cert/In-Use Code	Cert						
Vehicle Class	LDV/Passenger Car	Standard Level	Federal Tier 3 Bin 0						
Fuel	Electricity	Test Procedure	Multi-Cycle Test (MCT)						
Useful Life	Emission Name	Rounded Result	RAF	NMOG / NMHC	Upward Diesel Adjustment Factor	Downward Diesel Adjustment Factor	Mult DF	Add DF	Std
150,000 miles	CO	--	--	--	--	--	--	0	0
150,000 miles	CREE	--	--	--	--	--	--	0	0

Certification Summary Information Report

Test Group		TWHNV00.0LZB			Evaporative/Refueling Family			--		
Cert Region		Federal			Cert/In-Use Code			Cert		
Vehicle Class		LDV/Passenger Car			Standard Level			Federal Tier 3 Bin 0		
Fuel		Electricity			Test Procedure			SC03		
Useful Life	Emission Name	Rounded Result	RAF	NMOG / NMHC	Upward Diesel Adjustment Factor	Downward Diesel Adjustment Factor	Mult DF	Add DF	Std	
120,000 miles	CREE	--	--	--	--	--	--	0	0	
150,000 miles	CO	--	--	--	--	--	--	0	0	
Cert Region		Federal			Cert/In-Use Code			Cert		
Vehicle Class		LDV/Passenger Car			Standard Level			Federal Tier 3 Bin 0		
Fuel		Electricity			Test Procedure			HWFE		
Useful Life	Emission Name	Rounded Result	RAF	NMOG / NMHC	Upward Diesel Adjustment Factor	Downward Diesel Adjustment Factor	Mult DF	Add DF	Std	
150,000 miles	CO	--	--	--	--	--	--	0	0	
150,000 miles	CREE	--	--	--	--	--	--	0	0	
Cert Region		Federal			Cert/In-Use Code			Cert		
Vehicle Class		LDV/Passenger Car			Standard Level			Federal Tier 3 Bin 0		
Fuel		Electricity			Test Procedure			Charge Depleting 20 Degree F FTP		
Useful Life	Emission Name	Rounded Result	RAF	NMOG / NMHC	Upward Diesel Adjustment Factor	Downward Diesel Adjustment Factor	Mult DF	Add DF	Std	
150,000 miles	CO	--	--	--	--	--	--	0	0	
150,000 miles	CREE	--	--	--	--	--	--	0	0	

Certification Summary Information Report

Test Group	TWHNV00.0LZB	Evaporative/Refueling Family	--
Glossary			
Useful Life			
4	4,000 miles	120	120,000 miles
50	50,000 miles	150	150,000 miles
100	100,000 miles		
Emission Name			
HC-TOTAL	Total Hydrocarbon	AS-VOLT	Average System Voltage
CO	Carbon Monoxide	CO2 BAG 1	Bag 1 Carbon Dioxide
CO2	Carbon dioxide	CO2 BAG 2	Bag 2 Carbon Dioxide
CREE	Carbon-Related Exhaust Emissions	CO2 BAG 3	Bag 3 Carbon Dioxide
OPT-CREE	Optional Carbon-Related Exhaust Emissions	CO2 BAG 4	Bag 4 Carbon Dioxide
NOX	Nitrogen Oxide	NMOG+NOX	Non-methane organic gases plus Nitrogen Oxides
PM	Particulate Matter	NMOG+NOX-COMP	SFTP Composite Non-methane Organic Gases + Nitrogen Oxides
PM-COMP	SFTP Composite Particulate Matter	DT-IWRR	Drive Trace Inertia Work Ratio Rating
HC-NM	Non-methane Hydrocarbon	DT-ASCR	Drive Trace Absolute Speed Change Rating
OMHCE	Organic material Hydrocarbon Equivalent	DT-EER	Drive Trace Energy Economy Rating
OMNMHCE	Organic material non-methane HC equivalent	COMB-CREE	Combined Carbon-Related Exhaust Emissions
NMOG	Non-methane organic gases	COMB-OPT-CREE	Combined Optional Carbon-Related Exhaust Emissions
HCHO	Formaldehyde	HC-TOTAL-EQUIV	Total Hydrocarbon equivalent - Evap only
H3C2HO	Acetaldehyde	METHANE-COMB	Combined CH4 for HD 2b/3 vehicles only
HC-NM+NOX	SFTP Non-methane Hydrocarbon + Nitrogen Oxides for US06 or SC03	N2O-COMB	Combined Nitrous Oxide for HD 2b/3 vehicles only
HC-NM+NOX-COMP	SFTP Composite Non-methane Hydrocarbon + Nitrogen Oxides	LEAK-DIA	Effective Leak Diameter (inches)
CO-COMP	SFTP Composite Carbon Monoxide	LEAK-GAS CAP	Gas Cap Leakage (cc/min)
ETHANOL	C2H5OH - Ethanol	CO2-COMB	Combined Carbon Dioxide for HD 2b/3 Vehicles Only
FE BAG 1	Bag 1 Fuel Economy	KW-HRS	Integrated DC KW-HRS
FE BAG 2	Bag 2 Fuel Economy	CH4 BAG 1	Bag 1 Methane
FE BAG 3	Bag 3 Fuel Economy	CH4 BAG 2	Bag 2 Methane
FE BAG 4	Bag 4 Fuel Economy	CH4 BAG 3	Bag 3 Methane
MFR FE	Manufacturer Fuel Economy	CH4 BAG 4	Bag 4 Methane
HC	Hydrocarbon for Running Loss and ORVR	CO BAG 1	Bag 1 Carbon Monoxide
METHANE	CH4 - Methane	CO BAG 2	Bag 2 Carbon Monoxide
METHANOL	CH3OH - Methanol	CO BAG 3	Bag 3 Carbon Monoxide
N2O	Nitrous Oxide	CO BAG 4	Bag 4 Carbon Monoxide
SPITBACK	Spitback Hydrocarbon in grams	NMOG BAG 1	Bag 1 Non-methane organic gases
AMP-HRS	Integrated Amp-hours	NMOG BAG 2	Bag 2 Non-methane organic gases
START-SOC	System Start State of Charge Watt-hours	NMOG BAG 3	Bag 3 Non-methane organic gases
END-SOC	System End State of Charge Watt-hours	NMOG BAG 4	Bag 4 Non-methane organic gases
ACT-DISTANCE	Actual Distance Driven (miles)		
Certification Region			

Certification Summary Information Report

Test Group	TWHNV00.0LZB	Evaporative/Refueling Family	
CA	California + CAA Section 177 states	FA	Federal
Exhaust Emission Standard Level			
B1	Federal Tier 2 Bin 1	T3B160	Federal Tier 3 Bin 160
B2	Federal Tier 2 Bin 2	T3B125	Federal Tier 3 Bin 125
B3	Federal Tier 2 Bin 3	T3B110	Federal Tier 3 Transitional Bin 110
B4	Federal Tier 2 Bin 4	T3B85	Federal Tier 3 Transitional Bin 85
B5	Federal Tier 2 Bin 5	T3SULEV30	Federal Tier 3 Transitional LEV-II SULEV30 Carryover
B6	Federal Tier 2 Bin 6	T3B70	Federal Tier 3 Bin 70
B7	Federal Tier 2 Bin 7	T3B50	Federal Tier 3 Bin 50
B8	Federal Tier 2 Bin 8	T3B30	Federal Tier 3 Bin 30
B9	Federal Tier 2 Bin 9	T3B20	Federal Tier 3 Bin 20
B10	Federal Tier 2 Bin 10	T3B0	Federal Tier 3 Bin 0
B11	Federal Tier 2 Bin 11	HDV2B395	Federal Tier 3 HD Class 2b Transitional Bin 395
HDV1	HDV1 (Federal HD chassis Class 2b GVW 8501-10000)	HDV2B340	Federal Tier 3 HD Class 2b Transitional Bin 340
HDV2	HDV2 (Federal HD chassis Class 3 GVW 10001-14000)	HDV2B250	Federal Tier 3 HD Class 2b Bin 250
L2	California LEV-II LEV	HDV2B200	Federal Tier 3 HD Class 2b Bin 200
L2OP	California LEV-II LEV Optional	HDV2B170	Federal Tier 3 HD Class 2b Bin 170
U2	California LEV-II ULEV	HDV2B150	Federal Tier 3 HD Class 2b Bin 150
S2	California LEV-II SULEV	HDV2B0	Federal Tier 3 HD Class 2b Bin 0
ZEV	California ZEV	HDV3B630	Federal Tier 3 HD Class 3 Transitional Bin 630
OT	Other	HDV3B570	Federal Tier 3 HD Class 3 Transitional Bin 570
T1	Federal Tier 1	HDV3B400	Federal Tier 3 HD Class 3 Bin 400
PZEV	California PZEV	HDV3B270	Federal Tier 3 HD Class 3 Bin 270
L2LEV160	California LEV-II LEV160	HDV3B230	Federal Tier 3 HD Class 3 Bin 230
L2ULEV125	California LEV-II ULEV125	HDV3B200	Federal Tier 3 HD Class 3 Bin 200
L2SULEV30	California LEV-II SULEV30	HDV3B0	Federal Tier 3 HD Class 3 Bin 0
L2LEV395	California LEV-II LEV395	L4SULEV100	California LEV-IV SULEV100
L2ULEV340	California LEV-II ULEV340	L4SULEV125	California LEV-IV SULEV125
L2LEV630	California LEV-II LEV630	L4SULEV15	California LEV-IV SULEV15
L2ULEV570	California LEV-II ULEV570	L4SULEV150	California LEV-IV SULEV150
L3LEV160	California LEV-III LEV160	L4SULEV170	California LEV-IV SULEV170
L3ULEV125	California LEV-III ULEV125	L4SULEV175	California LEV-IV SULEV175
L3ULEV70	California LEV-III ULEV70	L4SULEV20	California LEV-IV SULEV20
L3ULEV50	California LEV-III ULEV50	L4SULEV200	California LEV-IV SULEV200
L3SULEV30	California LEV-III SULEV30	L4SULEV230	California LEV-IV SULEV230
L3SULEV20	California LEV-III SULEV20	L4SULEV25	California LEV-IV SULEV25
L3LEV395	California LEV-III LEV395	L4SULEV30	California LEV-IV SULEV30
L3ULEV340	California LEV-III ULEV340	L4SULEV75	California LEV-IV SULEV75
L3ULEV250	California LEV-III ULEV250	L4SULEV85	California LEV-IV SULEV85
L3ULEV200	California LEV-III ULEV200	L4ULEV125	California LEV-IV ULEV125

Certification Summary Information Report

Test Group		TWHNV00.0LZB	Evaporative/Refueling Family		--
L3SULEV170	California LEV-III SULEV170		L4ULEV200	California LEV-IV ULEV200	
L3SULEV150	California LEV-III SULEV150		L4ULEV250	California LEV-IV ULEV250	
L3LEV630	California LEV-III LEV630		L4ULEV270	California LEV-IV ULEV270	
L3ULEV570	California LEV-III ULEV570		L4ULEV40	California LEV-IV ULEV40	
L3ULEV400	California LEV-III ULEV400		L4ULEV400	California LEV-IV ULEV400	
L3ULEV270	California LEV-III ULEV270		L4ULEV50	California LEV-IV ULEV50	
L3SULEV230	California LEV-III SULEV230		L4ULEV60	California LEV-IV ULEV60	
L3SULEV200	California LEV-III SULEV200		L4ULEV70	California LEV-IV ULEV70	
Transmission Type Code					
AMS	Automated Manual- Selectable (e.g. Automated Manual with paddles)		M	Manual	
A	Automatic		OT	Other	
AM	Automated Manual		SA	Semi-Automatic	
CVT	Continuously Variable		SCV	Selectable Continuously Variable (e.g. CVT with paddles)	
Drive System Code					
4	4-Wheel Drive		P	Part-time 4-Wheel Drive	
F	2-Wheel Drive, Front		A	All Wheel Drive	
R	2-Wheel Drive, Rear				
Additional Terms and Acronyms					
AFC	Alternative Fuel Converter		ICI	Independent Commercial Importer	
CSI	Certificate Summary Information		ORVR	Onboard Refueling Vapor Recovery	
DF	Deterioration Factor		SIL	Shift Indicator Light	
Evap	Evaporation, Evaporative		Trans	Transmission	



08. Manufacturer Statement (Emission Testing Waiver)

Not Applicable. Not required for Battery Electric Vehicles.



09. OBD System Description

Not Applicable. Not required for Battery Electric Vehicles.



10. Description of Alternate-fueled Vehicles

Wuhan Lotus Co. Ltd. produces Battery Electric Vehicles.



11. AECD Description

Battery Electric Vehicle: No Auxiliary Emissions Control Devices



12. Description of vehicles covered by certificate and test parameters

List of Certified Vehicles

Durability Group	TWHNEEVNNLZB		
Test Group	TWHNV00.0LZB		
Emission Control	NA (BEV)		
Exhaust	NA (BEV)		
Evaporative	NA (BEV)		
Model	ELETRE R Long Range	ELETRE R Performance	
Carline	801	802	
Vehicle Class	LDV	LDV	LDV
Vehicle ID Tested	GIC_C10_6114	GIC_C10_6101	N.A.
ETW	6000	6000	6000
Curb Weight [lbs]	5820	5886	N.A.
Engine Code	LZB		
Drive type	AWD	AWD	AWD
Tire Size	Front: 275/40 R22 Rear: 315/35 R22	Front: 275/40 R22 Rear: 315/35 R22	Front: 275/35 R23 Rear: 315/30 R23
Axle Ratio	Front-1, Rear-1	Front-1, Rear-1	Front-1, Rear-1
N/V Ratio	Front-9.187 Rear- 1 st :13.645,2 nd :7.155	Front-9.187 Rear- 1 st :13.645,2 nd :7.155	Front-9.187 Rear- 1 st :13.645,2 nd :7.155
RLHP@50mph	14.84	15.72	15.52
Target RL A [lbf]	52.54	46.58	45.10
Target B [lbf/mph]	0.0264	0.4928	0.4928
Target C [lbf/mph^2]	0.0230	0.0187	0.0187

*Test vehicles are selected on worst case



Transmission

	ELETRE R Long Range ELETRE R Performance
Transmission Type	AT
Number of Transmission gears	Front: 1, Rear: 2

Battery details

Battery Type	Lithium-ion
Total Weight (kg)	665
Rated Voltage (V)	708
Rated Capacity (Ah)	158
Energy Density (Wh/kg)	168

Driving electric motor details

Engine Code	LZB
Front axle	
Front motor type	TZ230XS225
Working principle	AC, 3 Phases, Permanent magnet
Rated Speed (rpm)	17,000
Peak Power (kW)	225
Peak Torque (N.m)	355
Rear axle	
Rear motor type	TZ264XY000
Working principle	AC, 3 Phases, Permanent magnet
Rated Speed (rpm)	14,000
Peak Power (kW)	450
Peak Torque (N.m)	630



VEHICLE EMISSION CONTROL INFORMATION LABEL

Label size: 130mm*45mm

Label location: Inside of the hood

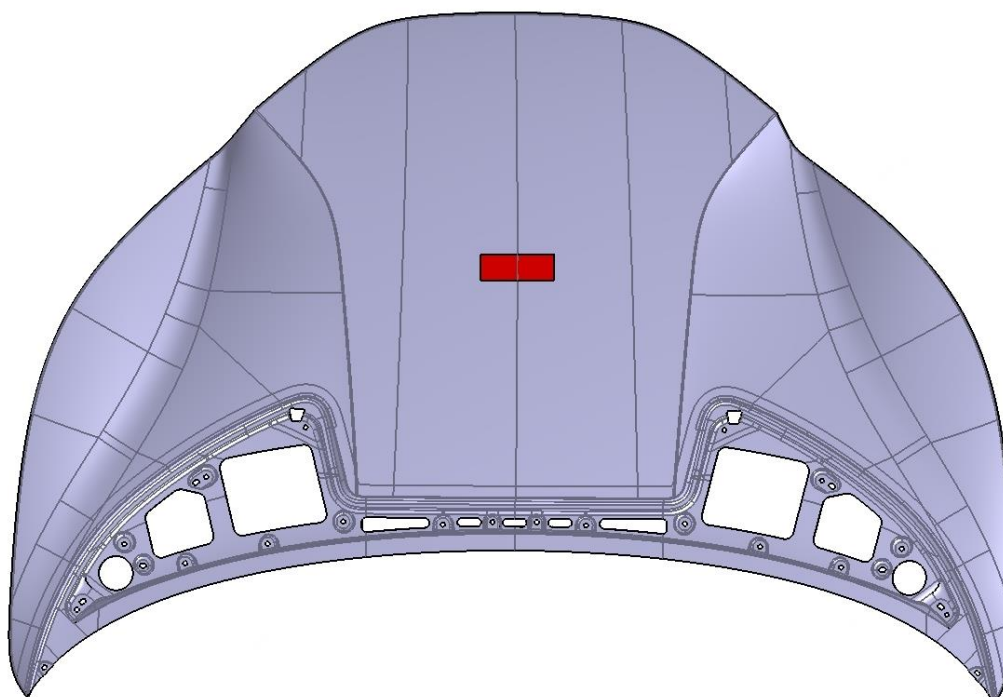

Label Sample:

	WUHAN LOTUS CARS CO.,LTD
VEHICLE EMISSION CONTROL INFORMATION	
THIS VEHICLE CONFORMS TO U.S. EPA REGULATIONS APPLICABLE TO 2026 MODEL YEAR NEW TIER 3 BIN 0 LIGHT-DUTY VEHICLES.	
Battery Electric Vehicle	
TEST GROUP:TWHNV00.0LZB	8600015883

100x30mm



Fuel Economy Label

Fuel Economy and Environment

Electric Vehicle

Fuel Economy

MPGe Midsize cars range from 10 to 99 MPGe. The best vehicle rates 99 MPGe.

combined city/hwy	city	highway	kW-hrs per 100 miles
Driving Range			
When fully charged, vehicle can travel about...			
0	20	40	60
Charge Time: hours (240V)			80
			miles

You save

in fuel costs over 5 years

compared to the average new vehicle.

Annual fuel cost

Fuel Economy & Greenhouse Gas Rating (tailpipe only)

10

1

10
Best

This vehicle emits 0 grams CO₂ per mile. The best emits 0 grams per mile (tailpipe only). Does not include emissions from generating electricity; learn more at fueleconomy.gov.

Smog Rating (tailpipe only)

1

10
Best

Actual results will vary for many reasons, including driving conditions and how you drive and maintain your vehicle. The average new vehicle gets 22 MPG and costs \$12,600 to fuel over 5 years. Cost estimates are based on 15,000 miles per year at \$0.12 per kW-hr. MPGe is miles per gasoline gallon equivalent. Vehicle emissions are a significant cause of climate change and smog.

fueleconomy.gov

Smartphone QR Code™

Calculate personalized estimates and compare vehicles



13. Projected Sales

Refer to Section 16 of this Test Group Application



14. Request for Certificate

Mr. David Wright

Light-Duty Vehicle Compliance Branch

Implementation, Analysis, and Compliance Division

U.S.Environmental Protection Agency

2000 Traverwood Drive

Ann Arbor, Michigan 48105

Subject: Request for issuance of a new Certificate of Conformity-Initial application

Dear Mr. David

Wuhan Lotus Cars Co., Ltd. (Lotus) herewith submits an application for Certification for 2026MY light-duty vehicles (LDV's) in test group **TWHNV00.0LEB** which comprises of all Zero Emission Vehicles

Lotus believes that all vehicles within this test group comply with all applicable regulations within Code of Federal Regulations Title 40 Parts 85, 86, 600.

Please do not hesitate to contact me if you have any questions regarding this submission.

Sincerely yours,

Wuhan Lotus Cars Co.. Ltd.

Ms Han FANG

Senior Director- Vehicle Homologation



15. Other Information

15.01. Revision Index

Section No.	Date:	Comments:	RC Number
Part I			
All	02/2026	Initial application	
Part II			
All	02/2026	Initial application	

15.02. Running Change

Model Year: 2026

Test Group: TWHNV00.0LEB

Model: ELETRE S Long Range, ELETRE S Performance

RC number	Description of change	Date

15.03. Fee Filling Form

Please refer to the following page.

US EPA Fee Form

[Help and EPA Instructions](#)

* Required Field

General Information

Date: 02/05/2026

Process Code *

Submit New Fee Filing Form

Manufacturer Code *

WHN

Manufacturer Name *

Wuhan Lotus Cars Co., Ltd.

Contact Name *

Ray Wang

Contact Email Address *

yiqun.wang7@geely.com

Contact Phone *

008613930348533

Calendar Year complete application submitted to EPA *

2026

PLEASE NOTE: These fees apply to complete certification applications received by EPA from January 1, 2026, through December 31, 2026. The applicable fee is determined by the

calendar year in which the complete certification application is received, not the model year.

Engine Family / Evaporative Family / Test Group *

TWHNV00.0LZB

Certificate Request Type (Industry Sector Code)

Certificate Request Type *

- On-Highway LDV, LTD, MDVPV, HDV Chassis Cert (Federal) (A, B, D, J, T, V)
- On-Highway HDE Dyno Cert (Federal) (E, H)
- On-Highway LD ICI, MDPV ICI, HDV ICI (A, B, D, J, T, V)
- On-Highway Motorcycle (C)
- On-Highway HDV Evap (F)
- On-Highway LDV, LTD, MDVPV, HDV Chassis Cert (California-Only) (A, B, D, J, T, V)
- On-Highway HDE Dyno Cert (California-Only) (E, H)
- Nonroad CI (L)
- Nonroad SI (B, S)
- Locomotive (G, K)
- All Nonroad Recreational, excluding Marine engines (X, Y)
- All Marine (Including IMO) (M, N, W)
- Component Certification for Evaporative Emissions (P)

IMO Name (Required for dual US/IMO Marine Only)

ICI VIN Number (Required for ICIs Only)

Do you qualify for a Reduced Fee? *

No

Payment Information

Amount Owed

\$32,317.00

Payment Type *

Offline Wire

Comments

MY2026 LOTUS Cars Test Group - ELETRE R

EPA Form Number 3520-29

OMB Control No. 2060-0545

Approval expires 7/31/2027

The public reporting and recordkeeping burden for this collection of information is estimated to average 12 minutes per response. Send comments on the Agency's need for this information, the accuracy of the provided burden estimates, and any suggested methods for minimizing respondent burden, including through the use of automated collection techniques to the Director, Collection Strategies Division, U.S. Environmental Protection Agency (2822T), 1200 Pennsylvania Ave., NW, Washington, D.C. 20460. Include the OMB control number in any correspondence. Do not send the completed forms to this address.

The content of this document may contain Sensitive But Unclassified (SBU) data and/or Controlled Unclassified Information (CUI).



16. Confidential Information

N/A