

US EPA ARCHIVE DOCUMENT

FINAL

Coal Combustion Residue Impoundment

Round 12 - Dam Assessment Report

Big Brown Steam Electric Station

Bottom Ash Pond

Fairfield, Texas

Luminant Generation Co., LLC

Prepared for:

United States Environmental Protection Agency
Office of Resource Conservation and Recovery

Prepared by:

Dewberry Consultants LLC
Fairfax, Virginia



Under Contract Number: EP-09W001727

March 2014

FINAL

INTRODUCTION, SUMMARY CONCLUSIONS AND RECOMMENDATIONS

The release of over five million cubic yards of coal combustion residue from the Tennessee Valley Authority's Kingston, Tennessee facility in December 2008, which flooded more than 300 acres of land and damaged homes and property, is a wake-up call for diligence on coal combustion residue disposal units. A first step toward this goal is to assess the stability and functionality of the ash impoundments and other units, then quickly take any needed corrective measures.

This assessment of the stability and functionality of the Big Brown Steam Electric Station Bottom Ash Pond impoundment dikes is based on a review of available documents and on the site assessment conducted by Dewberry personnel on September 26, 2012. We found the supporting technical documentation adequate (Section 1.1.3). Subsequent to the submittal of Dewberry's Draft report, Luminant provided the Ash Pond Slope Stability Investigation Report conducted by Golder Associates.

Based on the new information, the Big Brown Steam Electric Station Bottom Ash Pond management unit is **SATISFACTORY** for continued safe and reliable operation.

PURPOSE AND SCOPE

The U.S. Environmental Protection Agency (EPA) is investigating the potential for catastrophic failure of Coal Combustion Surface Impoundments (i.e., management unit) from occurring at electric utilities in an effort to protect lives and property from the consequences of a dam failure or the improper release of impounded slurry. The EPA initiative is intended to identify conditions that may adversely affect the structural stability and functionality of a management unit and its appurtenant structures (if present); to note the extent of deterioration (if present), status of maintenance and/or a need for immediate repair; to evaluate conformity with current design and construction practices; and to determine the hazard potential classification for units not currently classified by the management unit owner or by a state or federal agency. The initiative will address management units that are classified as having a Less-than-Low, Low, Significant, or High Hazard Potential ranking (for Classification, see pp. 3-8 of the 2004 Federal Guidelines for Dam Safety).

In early 2009, the EPA sent letters to coal-fired electric utilities seeking information on the safety of surface impoundments and similar facilities that receive liquid-borne material that store or dispose of coal combustion residue. This letter was issued under the authority of the Comprehensive Environmental Response, Compensation, and Liability Act (CERCLA) Section 104(e), to assist the Agency in assessing the structural stability and functionality of such management units, including which facilities should be visited to perform a safety assessment of the berms, dikes, and dams used in the construction of these impoundments.

FINAL

EPA requested that utility companies identify all management units including surface impoundments or similar diked or bermed management units or management units designated as landfills that receive liquid-borne material used for the storage or disposal of residuals or by-products from the combustion of coal, including, but not limited to, fly ash, bottom ash, boiler slag, or flue gas emission control residuals. Utility companies provided information on the size, design, age and the amount of material placed in the units.

The purpose of this report is **to evaluate the condition and potential of residue release from management units and to determine the hazard potential classification**. This evaluation included a site visit. Prior to conducting the site visit, a two-person team reviewed the information submitted to EPA, reviewed any relevant publicly available information from state or federal agencies regarding the unit hazard potential classification (if any) and accepted information provided via telephone communication with the management unit owner.

This report presents the opinion of the assessment team as to the potential of catastrophic failure and reports on the condition of the management unit(s).

Note: The terms “embankment”, “berm”, “dike” and “dam” are used interchangeably within this report, as are the terms “pond”, “basin”, and “impoundment”.

LIMITATIONS

The assessment of dam safety reported herein is based on field observations and review of readily available information provided by the owner/operator of the subject coal combustion residue management unit(s). Qualified Dewberry engineering personnel performed the field observations and review and made the assessment in conformance with the required scope of work and in accordance with reasonable and acceptable engineering practices. No other warranty, either written or implied, is made with regard to our assessment of dam safety.

FINAL

Table of Contents

| | <u>Page</u> |
|---|-------------|
| INTRODUCTION, SUMMARY CONCLUSIONS AND RECOMMENDATIONS..... | ii |
| PURPOSE AND SCOPE | ii |
| 1.0 CONCLUSIONS AND RECOMMENDATIONS | 1-1 |
| 1.1 CONCLUSIONS | 1-1 |
| 1.1.1 <i>Conclusions Regarding the Structural Soundness of the Management Unit(s)</i> | 1-1 |
| 1.1.2 <i>Conclusions Regarding the Hydrologic/Hydraulic Safety of the Management Unit</i> | 1-1 |
| 1.1.3 <i>Conclusions Regarding the Adequacy of Supporting Technical Documentation</i> | 1-1 |
| 1.1.4 <i>Conclusions Regarding the Description of the Management Unit(s)</i> | 1-2 |
| 1.1.5 <i>Conclusions Regarding the Field Observations</i> | 1-2 |
| 1.1.6 <i>Conclusions Regarding the Adequacy of Maintenance and Methods of Operation</i> | 1-2 |
| 1.1.7 <i>Conclusions Regarding the Adequacy of the Surveillance and Monitoring Program</i> | 1-2 |
| 1.1.8 <i>Classification Regarding Suitability for Continued Safe and Reliable Operation</i> | 1-3 |
| 1.2 RECOMMENDATIONS | 1-3 |
| 1.2.1 <i>Recommendations Regarding Structural Stability</i> | 1-3 |
| 1.2.2 <i>Recommendations Regarding the Supporting Technical Documentation</i> | 1-3 |
| 1.2.3 <i>Recommendations Regarding Continued Safe and Reliable Operation</i> | 1-3 |
| 1.3 PARTICIPANTS AND ACKNOWLEDGEMENT | 1-3 |
| 1.3.1 <i>List of Participants</i> | 1-3 |
| 1.3.2 <i>Acknowledgement and Signature</i> | 1-3 |
| 2.0 DESCRIPTION OF THE COAL COMBUSTION RESIDUE MANAGEMENT UNIT(S)..... | 2-1 |
| 2.1 LOCATION AND GENERAL DESCRIPTION | 2-1 |
| 2.2 COAL COMBUSTION RESIDUE HANDLING | 2-2 |
| 2.2.1 <i>Fly Ash</i> | 2-2 |
| 2.2.2 <i>Bottom Ash</i> | 2-2 |
| 2.2.3 <i>Boiler Slag</i> | 2-3 |
| 2.2.4 <i>Flue Gas Desulfurization Sludge</i> | 2-3 |
| 2.3 SIZE AND HAZARD CLASSIFICATION | 2-3 |
| 2.4 AMOUNT AND TYPE OF RESIDUALS CURRENTLY CONTAINED IN THE UNIT(S) AND MAXIMUM CAPACITY | 2-4 |
| 2.5 PRINCIPAL PROJECT STRUCTURES | 2-4 |
| 2.5.1 <i>Earth Embankment</i> | 2-4 |
| 2.5.2 <i>Outlet Structures</i> | 2-5 |
| 2.6 CRITICAL INFRASTRUCTURE WITHIN FIVE MILES DOWN GRADIENT | 2-5 |
| 3.0 SUMMARY OF RELEVANT REPORTS, PERMITS, AND INCIDENTS | 3-1 |
| 3.1 SUMMARY OF REPORTS ON THE SAFETY OF THE MANAGEMENT UNITS | 3-1 |
| 3.2 SUMMARY OF LOCAL, STATE, AND FEDERAL ENVIRONMENTAL PERMITS..... | 3-1 |
| 3.3 SUMMARY OF SPILL/RELEASE INCIDENTS | 3-1 |

FINAL

| | | |
|------------|--|------------|
| 4.0 | SUMMARY OF HISTORY OF CONSTRUCTION AND OPERATION | 4-1 |
| 4.1 | SUMMARY OF CONSTRUCTION HISTORY | 4-1 |
| 4.1.1 | <i>Original Construction</i> | 4-1 |
| 4.1.2 | <i>Significant Changes/Modifications in Design since Original Construction</i> | 4-1 |
| 4.1.3 | <i>Significant Repairs/Rehabilitation since Original Construction</i> | 4-2 |
| 4.2 | SUMMARY OF OPERATIONAL PROCEDURES | 4-2 |
| 4.2.1 | <i>Original Operational Procedures</i> | 4-2 |
| 4.2.2 | <i>Significant Changes in Operational Procedures and Original Startup</i> | 4-2 |
| 4.2.3 | <i>Current Operational Procedures</i> | 4-2 |
| 4.2.4 | <i>Other Notable Events since Original Startup</i> | 4-2 |
| 5.0 | FIELD OBSERVATIONS | 5-1 |
| 5.1 | PROJECT OVERVIEW AND SIGNIFICANT FINDINGS | 5-1 |
| 5.2 | BOTTOM ASH POND | 5-1 |
| 5.2.1 | <i>Crest</i> | 5-1 |
| 5.2.2 | <i>Upstream/Inside Slope</i> | 5-2 |
| 5.2.3 | <i>Downstream/Outside Slope and Toe</i> | 5-3 |
| 5.2.4 | <i>Abutments and Groin Areas</i> | 5-4 |
| 5.3 | OUTLET STRUCTURES | 5-4 |
| 5.3.1 | <i>Overflow Structure</i> | 5-4 |
| 5.3.2 | <i>Outlet Conduit</i> | 5-5 |
| 5.3.3 | <i>Emergency Spillway</i> | 5-5 |
| 5.3.4 | <i>Low Level Outlet</i> | 5-5 |
| 6.0 | HYDROLOGIC/HYDRAULIC SAFETY | 6-1 |
| 6.1 | SUPPORTING TECHNICAL DOCUMENTATION | 6-1 |
| 6.1.1 | <i>Flood of Record</i> | 6-1 |
| 6.1.2 | <i>Inflow Design Flood</i> | 6-1 |
| 6.1.3 | <i>Spillway Rating</i> | 6-2 |
| 6.1.4 | <i>Downstream Flood Analysis</i> | 6-2 |
| 6.2 | ADEQUACY OF SUPPORTING TECHNICAL DOCUMENTATION | 6-2 |
| 6.3 | ASSESSMENT OF HYDROLOGIC/HYDRAULIC SAFETY | 6-2 |
| 7.0 | STRUCTURAL STABILITY | 7-1 |
| 7.1 | SUPPORTING TECHNICAL DOCUMENTATION | 7-1 |
| 7.1.1 | <i>Stability Analyses and Load Cases Analyzed</i> | 7-1 |
| 7.1.2 | <i>Design Parameters and Dam Materials</i> | 7-2 |
| 7.1.3 | <i>Uplift and/or Phreatic Surface Assumptions</i> | 7-2 |
| 7.1.4 | <i>Factors of Safety and Base Stresses</i> | 7-2 |
| 7.1.5 | <i>Liquefaction Potential</i> | 7-4 |
| 7.1.6 | <i>Critical Geological Conditions</i> | 7-4 |
| 7.2 | ADEQUACY OF SUPPORTING TECHNICAL DOCUMENTATION | 7-4 |
| 7.3 | ASSESSMENT OF STRUCTURAL STABILITY | 7-4 |

FINAL

| | | |
|------------|---|------------|
| 8.0 | ADEQUACY OF MAINTENANCE AND METHODS OF OPERATION | 8-1 |
| 8.1 | OPERATING PROCEDURES | 8-1 |
| 8.2 | MAINTENANCE OF THE DAM AND PROJECT FACILITIES | 8-1 |
| 8.3 | ASSESSMENT OF MAINTENANCE AND METHODS OF OPERATIONS | 8-1 |
| 8.3.1 | <i>Adequacy of Operating Procedures</i> | <i>8-1</i> |
| 8.3.2 | <i>Adequacy of Maintenance</i> | <i>8-1</i> |
| 9.0 | ADEQUACY OF SURVEILLANCE AND MONITORING PROGRAM | 9-1 |
| 9.1 | SURVEILLANCE PROCEDURES | 9-1 |
| 9.2 | INSTRUMENTATION MONITORING | 9-1 |
| 9.3 | ASSESSMENT OF SURVEILLANCE AND MONITORING PROGRAM..... | 9-1 |
| 9.3.1 | <i>Adequacy of Inspection Program.....</i> | <i>9-1</i> |
| 9.3.2 | <i>Adequacy of Instrumentation Monitoring Program</i> | <i>9-1</i> |

APPENDIX A

- Doc 01: Bottom Ash Pond Design Drawing 119-1134-301 Sheets 1 - 3
- Doc 02: Big Brown Bottom Ash Pond Weekly Inspection Reports for September 6 and 11, 2012
- Doc 03: Big Brown Critical Impoundment Inspection Report, Luminant Fossil Engineering Services, February 21, 2011
- Doc 04: Big Brown Critical Impoundment Inspection Report, HDR Engineering, Inc., April 19, 2012
- Doc 05: NPDES Permit No. TN 85003-0-02
- Doc 06: FLOW CHART, Big Brown Steam Electric Station

APPENDIX B

- Doc 07: Dam Inspection Check List Lime and Ash Pond

APPENDIX C

- Doc 08: Ash Pond Slope Stability Investigation Report, Golder Associates Inc. November 2012 (Revised December 2012)

1.0 CONCLUSIONS AND RECOMMENDATIONS

1.1 CONCLUSIONS

Conclusions are based on visual observations from a one-day site visit, September 26, 2012, and review of technical documentation provided by the Luminant.

1.1.1 Conclusions Regarding the Structural Soundness of the Management Unit(s)

The dike embankments appear to be structurally sound based on Dewberry engineers' observations during the site visit. However, documentation of slope stability Factors of Safety under static and seismic conditions for the Bottom Ash Pond was not provided for review. Subsequent to Dewberry's Draft submittal Golder Associates completed the Ash Pond slope stability analyses (See Doc 08 in Appendix C). Based on the new documentation of slope stability factors of safety, the embankments are rated SATISFACTORY for structural soundness.

1.1.2 Conclusions Regarding the Hydrologic/Hydraulic Safety of the Management Unit

Documentation of the hydrologic and hydraulic safety was not provided to Dewberry for review. However, since the pond only receives ash sluice water at a controlled rate and direct rainfall, the safety of the pond can be determined without an extensive hydrologic analysis. The normal pool elevation of the Bottom Ash Pond is managed to a relatively constant +347 feet, providing a 3-ft. freeboard. Dewberry examined the 100-year rainfall event and compared the data with the available freeboard. The freeboard should be adequate to contain the one-percent probability, 24-hour precipitation event (10.6 inches) without overtopping the impoundment embankments.

Based on the information reviewed the management unit is rated SATISFACTORY for hydrologic and hydraulic safety.

1.1.3 Conclusions Regarding the Adequacy of Supporting Technical Documentation

The supporting technical documentation is adequate although no documentation for the hydrologic and hydraulic safety analyses was provided to Dewberry for review.

FINAL

1.1.4 Conclusions Regarding the Description of the Management Unit(s)

The description of the management unit provided by the owner was an accurate representation of what Dewberry observed in the field.

1.1.5 Conclusions Regarding the Field Observations

Dewberry staff was provided access to all areas in the vicinity of the management unit required to conduct a thorough field observation. The visible parts of the embankments were observed to have no signs of overstress, significant settlement, shear failure, or other signs of instability. Embankments appear structurally sound. There are no apparent indications of unsafe conditions or conditions needing remedial action.

The Bottom Ash Pond does not have an outlet spillway. After the bottom ash is collected at the dewatering bins, the transport water is returned to the two-celled Bottom Ash Pond at the east end of the impoundment. Water, from sluice water and precipitation, is removed using a 42-in. diameter pipe through the west end of each cell. The discharge pipes lead to below grade control valves which are used to recycle water back through the plant.

1.1.6 Conclusions Regarding the Adequacy of Maintenance and Methods of Operation

The Bottom Ash Pond appears to be well maintained with no outstanding issues.

1.1.7 Conclusions Regarding the Adequacy of the Surveillance and Monitoring Program

The Bottom Ash Pond monitoring program consists of reading groundwater levels, and collecting samples for water quality testing from the piezometers installed near the toe of the embankments. Piezometer readings are taken on a semi-annual basis.

The surveillance program consists of weekly inspections with results recorded on site checklists, and formal annual inspections documented with formal written report.

FINAL

1.1.8 Classification Regarding Suitability for Continued Safe and Reliable Operation

The Bottom Ash Pond Cell impoundment embankments are rated SATISFACTORY for continued safe and reliable operation.

1.2 RECOMMENDATIONS

1.2.1 Recommendations Regarding Structural Stability

Based on the new report (Ash Pond Slope Stability Investigation Report, See Doc 08 in Appendix C) no recommendations are warranted regarding structural stability.

1.2.2 Recommendations Regarding the Supporting Technical Documentation

Since Dewberry issuance of the Draft Report Luminant submitted additional documentation, see Doc 08 in Appendix C. The supporting technical documentation is adequate.

1.2.3 Recommendations Regarding Continued Safe and Reliable Operation

No recommendations for continued safe and reliable operation of the management unit are warranted at this time.

1.3 PARTICIPANTS AND ACKNOWLEDGEMENT



1.3.1 List of Participants

Eric Chavers, Big Brown Steam Electric Station
Joe Hubbert, Big Brown Steam Electric Station
Phillip Street, Big Brown Steam Electric Station
Jeffrey White, Big Brown Steam Electric Station
Gary Spicer, Luminant
Karla Henson, Luminant
Mark Kelly, Luminant
Patrick Kelly, US EPA Washington, D.C.
Golam Mustafa, US EPA Regions 6
Joseph P. Klein, III, P.E., Dewberry
Michael McLaren, P.E., Dewberry

1.3.2 Acknowledgement and Signature

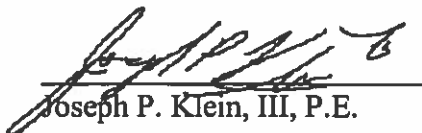
We acknowledge that the management unit referenced herein has been assessed on August 20, 2012.

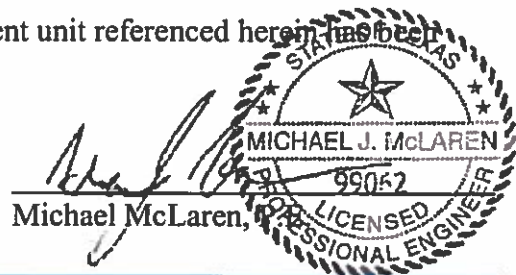
Joseph P. Klein, III, P.E.

Michael McLaren, P.E.

FINAL

2.0 DESCRIPTION OF THE COAL COMBUSTION RESIDUE MANAGEMENT UNIT(S)

2.1 LOCATION AND GENERAL DESCRIPTION

The Big Brown Steam Electric Station (Big Brown SES) is located on Texas Farm to Market (FM) Route 2570 about 10 miles northeast of Fairfield, Freestone County, Texas. Fairfield is about 140 miles northwest of Houston, Texas. The coordinates of the plant site are 31.8218° N and 96.0610° W. The site abuts the northeast corner of Fairfield reservoir, which was constructed to provide cooling water for the plant.

The Bottom Ash Pond is a single diked impoundment divided into two cells by an interior divider dike. The impoundment is about 1,400 feet long by about 600 feet wide. The long axis is oriented in the east-west direction. The impoundment is divided into two approximately equal cells, designated the North and South Ash Ponds. The cells are separated by an engineered divider dike that was part of the original facility constructions. Figure 2.1a depicts a vicinity map around the Big Brown SES. Figure 2.1b depicts an aerial view of the Big Brown SES and the CCR impoundment. Table 2.1 presents size information about the active disposal areas.

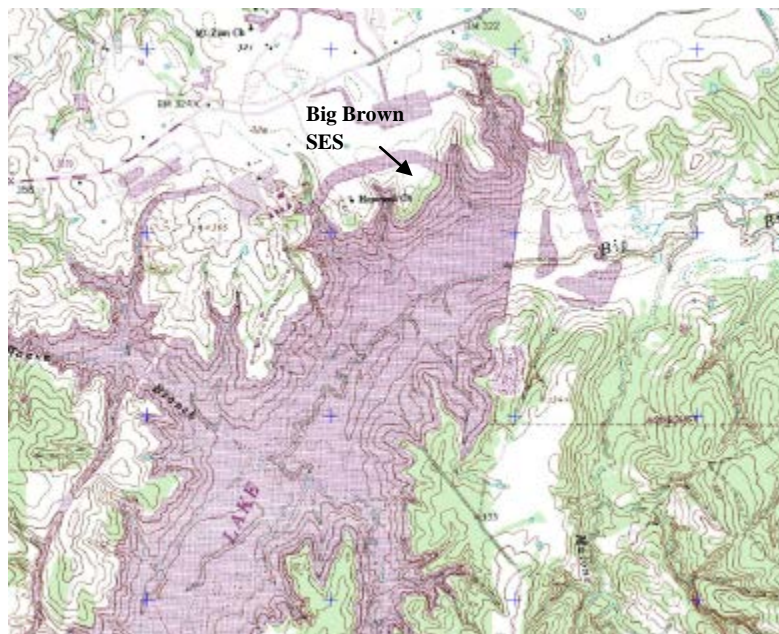

Figure 2.1 a: Big Brown SES Plant Vicinity Map

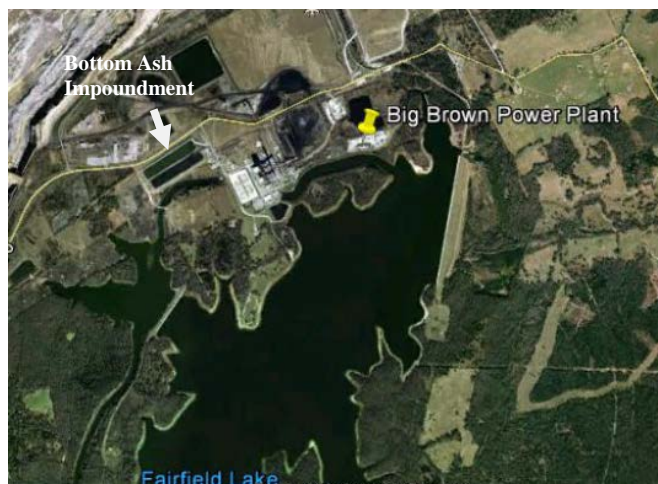

Figure 2.1 b: Big Brown SES and Bottom Ash Impoundment Locations

| Table 2.1: Summary of Dam Dimensions and Size ¹ | |
|--|-----------------------------------|
| | Bottom Ash Pond |
| Dam Height (ft) | 25 |
| Crest Width (ft) | 25 |
| Length (ft) | 4,000 |
| Side Slopes (upstream) H:V | 2.5:1 |
| Side Slopes (downstream) H:V | 2.0:1 to 2.2:1 varies by location |

¹ Dimensions based on design drawings prepared by Luminant (See Appendix A – Doc 01)

2.2 COAL COMBUSTION RESIDUE HANDLING

2.2.1 Fly Ash

Information provided by Luminant indicates that fly ash is handled dry for off-site beneficial reuse or land disposal.

2.2.2 Bottom Ash

Bottom ash is sluiced to bins and dewatered. After dewatering, bottom ash is transported offsite for beneficial re-use or land disposal as solid waste. (Photograph 2.2.2-1).

FINAL



Photograph 2.2.2-1: Ash sluice water return pipes from dewatering bins to Bottom Ash Pond

2.2.3 Boiler Slag

Boiler slag is handled with the bottom ash.

2.2.4 Flue Gas Desulfurization Sludge

No scrubbers are used in this plant so there is no flue gas desulfurization (FGD) process or related waste products to be discharged.

2.3 SIZE AND HAZARD CLASSIFICATION

Based on the size of the Bottom Ash Pond embankment height and impoundment storage capacity, the impoundment would be classified as Small by US Army Corps of Engineers (USACE) criteria.

| Table 2.2a: USACE ER 1110-2-106 Size Classification | | |
|--|------------------------|--------------------|
| Category | Impoundment | |
| | Storage (Ac-ft) | Height (ft) |
| Small | 50 and < 1,000 | 25 and < 40 |
| Intermediate | 1,000 and < 50,000 | 40 and < 100 |
| Large | > 50,000 | > 100 |

Federal guidelines for dam safety hazard classification use two criteria: potential loss of human life and economic, environmental and lifeline losses. Per the Federal Guidelines for Dam Safety dated April 2004, a Significant Hazard Potential classification applies to those dams where failure or misoperation results in no probable loss of human life but can cause economic loss, environmental damage,

FINAL

disruption of lifeline facilities, or can impact other concerns. Significant Hazard Potential dams are often located in agricultural areas.

Luminant representatives reported that the company owns most of the property in the vicinity of the plant, including the lake and dam. Land near the south end of the lake operated as a State Park is owned by Luminant and leased to the State of Texas for a nominal amount. Failure or misoperation of the impoundment is not expected to result in a probable loss of human life, and the economic and environmental losses are expected to be contained on the owner's property. Therefore, a Federal Hazard Classification of **LOW** is appropriate for these facilities.

| Table 2.2b: FEMA Federal Guidelines for Dam Safety Hazard Classification | | |
|---|--------------------------------|--|
| Classification | Loss of Human Life | Economic or Environmental Damage |
| Low | None Expected | Low and generally limited to owner site |
| Significant | None Expected | Yes |
| High | Probable. One or more expected | Yes (but not necessary for classification) |

2.4 AMOUNT AND TYPE OF RESIDUALS CURRENTLY CONTAINED IN THE UNIT(S) AND MAXIMUM CAPACITY

The Bottom Ash Pond generally only receives sluiced bottom ash and direct precipitation.

| | Bottom Ash Pond |
|---|------------------------|
| Surface Area (acre) | 19.3 |
| Current Storage Capacity (cubic yards) | 110,352 |
| Current Storage Capacity (acre-feet) | 68.4 |
| Total Storage Capacity (cubic yards) | 367,840 |
| Total Storage Capacity (acre-feet) | 228 |
| Crest Elevation (feet) | +350.0 |
| Normal Pond Level (feet) | +347.0 |

2.5 PRINCIPAL PROJECT STRUCTURES

2.5.1 Earth Embankment

The embankments consist of compacted earth fill with a 3-ft. thick compacted clay liner on the inside slope. Geotextile erosion control fabric

FINAL

has been installed along the inside slope to mitigate the impacts of wind driven wave action.

The exterior slopes are vegetated with various grasses and small weeds. The slopes are free of trees, tall bushes, or other vegetation potentially deleterious to slope stability.

2.5.2 Outlet Structures

Sluice water in each Bottom Ash Pond cell drains to the west portion of the cell. A concrete pipe drop inlet riser allows decant water into a reinforced concrete discharge pipe that passes through the west embankment to a valve control pit. The discharge pipe diameters are 30-in. at the north cell and 42-in. at the south cell. The inlet elevation of the decant risers is +342.7 ft.

There are no other outlets from the Bottom Ash Pond.

2.6 CRITICAL INFRASTRUCTURE WITHIN FIVE MILES DOWN GRADIENT

The Big Brown SES is located near the northeast corner of Fairfield Lake, about 10 miles northeast of Fairfield Texas. Area topographic conditions are shown on Figure 2.6-1. Observations of the area around the plant site and nearby roads did not identify critical infrastructure within 5 miles of the plant other than the electric transmission lines from the plant.

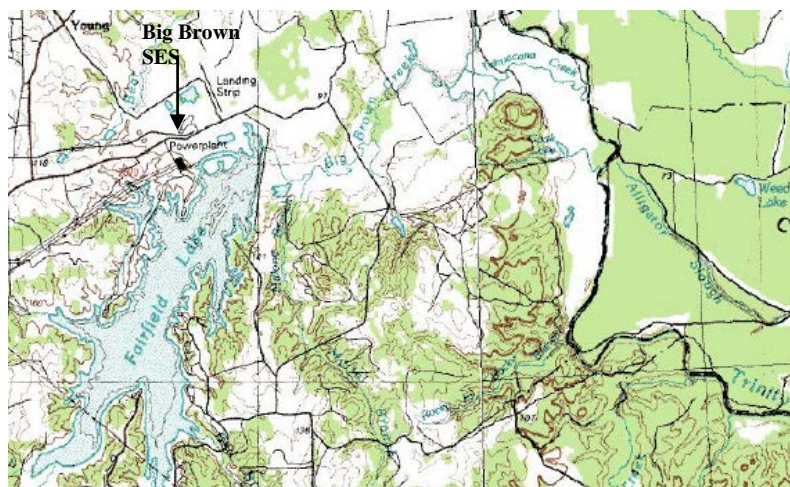

Figure 2.6-1: Bottom Ash Pond Area Topography

FINAL

3.0 SUMMARY OF RELEVANT REPORTS, PERMITS, AND INCIDENTS

3.1 SUMMARY OF REPORTS ON THE SAFETY OF THE MANAGEMENT UNITS

Luminant provided representative 2012 weekly inspection reports prepared by plant personnel for the Bottom Ash Pond. The inspection reports focus on the Bottom Ash Pond pool elevation, and observations of the embankments. No issues were identified in the reports provided which covered inspections for September 6, 2012 and September 11, 2012 (See Appendix A – Doc 2).

Luminant also provided the 2011 annual inspection report prepared by Luminant technical staff, and the 2012 annual inspection report prepared by HDR Engineering, Inc. Findings of the 2011 inspections were generally minor issues related to erosion from recent rains, vegetation maintenance, and animal scrapings disturbing areas of the embankment slopes (See Appendix A – Doc 3).

The 2012 annual inspection report indicates the inspection was conducted shortly after several day of rain of about 1.2 in. fell at the plant. Findings of the 2012 report were generally minor issues related to erosion rills, animal burrows, areas of standing water near the toe of the slope, tire ruts on the embankment crest, and vegetation maintenance (See Appendix A – Docs 3 and 4).

3.2 SUMMARY OF LOCAL, STATE, AND FEDERAL ENVIRONMENTAL PERMITS

The Texas Commission on Environmental Quality has issued a Texas Pollutant Discharge Elimination System Permit. Permit No. WQ0001309000 was issued April 18, 2007 (See Appendix A – Doc 05). The permit expired February 1, 2012. Luminant submitted an application for renewal which is still being reviewed by the State.

3.3 SUMMARY OF SPILL/RELEASE INCIDENTS

No recent documented spills or releases have been reported for the Bottom Ash Pond.

FINAL

4.0 SUMMARY OF HISTORY OF CONSTRUCTION AND OPERATION

4.1 SUMMARY OF CONSTRUCTION HISTORY

4.1.1 Original Construction

Based on construction drawings provided to Dewberry for review, the Bottom Ash Pond was designed and constructed in 1989. Dimensions of the Bottom Ash Pond are about 1,600 feet at the base along the east-west axis, and 600 feet along the north-south axis (See Appendix A – Doc. 1). The pond is divided into north and south cells by an interior divided dike.

The dikes were constructed of compacted soil fill excavated from within the pond plan area.

Discharge from each of the two cells in the Bottom Ash Pond is through a pipe to a valve pit located near the toe of the west embankment. Valves in the pit control flow back to the plant for recycling. There are no other outlets from the Bottom Ash Pond (See Appendix A – Doc 01). In an emergency, portable pumps would be deployed to pump water from the impoundment into the nearby plant cooling water discharge canal.

Each cell receives sluiced bottom ash and boiler slag through dedicated pipes. In the event there is a need to transfer liquid between cells, a mobile pump connected to HDPE pipes is used. The HDPE pipes are located at the opposite end of the ponds from the incoming sluice pipes.

4.1.2 Significant Changes/Modifications in Design since Original Construction

Drawings provided to Dewberry during the site visit indicate the embankment design was modified in 1999 to include a 3-ft. thick compacted clay liner along the interior side of the embankments and the impoundment bottom. Drawing General Notes specify that the clay liners shall have a permeability of 1×10^{-7} cm/sec.

The 1999 design also modified the discharge pipe from the south cell by replacing the original 30-in. diameter concrete pipe with a 42-in. diameter concrete pipe. Other modifications included adjustments to the outfall access bridges, and sluice pipe support structures to accommodate the addition of the 3-ft. thick liner.

FINAL

4.1.3 Significant Repairs/Rehabilitation since Original Construction

No significant repairs or rehabilitation have been made to the Bottom Ash Pond other than the 1999 design changes.

4.2 SUMMARY OF OPERATIONAL PROCEDURES

4.2.1 Original Operational Procedures

Bottom ash from coal combustion is sluiced to dewatering bins. Bottom ash sluice water flows to the Bottom Ash Pond. The bottom ash from the de-watering bins is transported off-site for beneficial re-use or land disposal as solid waste (See Appendix A – Doc. 06).

The Bottom Ash Pond may also receive metal-cleaning wastes, and waste water treatment wastes. However, fly ash is normally managed dry and transported off-site for beneficial reuse or land disposal as solid waste.

Big Brown SES does not have scrubbers.

4.2.2 Significant Changes in Operational Procedures and Original Startup

Based on information provided to Dewberry during the site visit, no significant change in operational procedures have been made since the 1999 design upgrades were completed.

4.2.3 Current Operational Procedures

Based on observations made during the Dewberry site visit current operations are substantively the same as described in the original operational procedures.

4.2.4 Other Notable Events since Original Startup

No notable events were reported to Dewberry during our site visit.

FINAL

5.0 FIELD OBSERVATIONS

5.1 PROJECT OVERVIEW AND SIGNIFICANT FINDINGS

Dewberry personnel Michael McLaren, P.E., and Joseph P. Klein, III, P.E. conducted a site visit on September 26, 2012 in company with the participants.

The site visit began at 9:00 AM. The weather was sunny and warm. Photographs were taken of conditions observed. Please refer to the Dam Inspection Checklist in Appendix B for additional information. Selected photographs are included here for ease of visual reference. All pictures were taken by Dewberry personnel during the site visit. Copies of all photographs were provided to Luminant representatives.

The overall visual assessment of the dam slopes was that the dikes are in satisfactory condition and no significant findings were noted.

5.2 BOTTOM ASH POND

5.2.1 Crest

Overall, there were no signs of rutting, depressions, tension cracking, or other indications of settlement or shear failure and the crest appeared to be in satisfactory condition (see Figure 5.2.1-1).



**Figure 5.2.1-1 North Dike Crest View West
Along Bottom Ash Pond**

FINAL

5.2.2 Upstream/Inside Slope

No scarps, sloughs, depressions, bulging or other indications of slope instability were observed (see Figure 5.2.2-1). Vegetation along the interior slope generally consisted of various types of grass and weeds.



Figure 5.2.2-1 Interior Slope South Embankment

Isolated areas of erosion from wind generated waves were observed on the interior slopes of the east and west embankments. It appears that recent lack of rain has had an adverse impact on vegetation planted to mitigate wave erosion. (See Figure 5.2.2-2)



**Figure 5.2.2-2 Area of Interior Slope Erosion
– West Embankment**

FINAL

5.2.3 Downstream/Outside Slope and Toe

No scarps, sloughs, depressions, bulging or other indications of slope instability or signs of erosion were observed. Exterior slopes were vegetated with grass, and weeds (See Figure 5.2.3-1).



Figure 5.2.3-1 North Embankment Outside Slope and Toe

The plant cooling water discharge canal passes near the center of the north embankment on its path to the main lake (See Figure 5.2.3-2)



Figure 5.2.3-2 Plant Cooling Water Discharge Canal near Bottom Ash Pond North Embankment

FINAL

No evidence of seepage was observed in the exterior slopes or along the toe of the embankments.

5.2.4 Abutments and Groin Areas

The Bottom Ash Pond is a fully diked impoundment with no abutments. Groins were found to be in satisfactory condition with no signs of distress (See Figure 5.2.4-1)



Figure 5.2.4-1: Bottom Ash Pond Northeast Groin

5.3 OUTLET STRUCTURES

5.3.1 Overflow Structure

The north and south cells of the Bottom Ash Pond each have an overflow structure. Each overflow structure consists of a concrete pipe riser connected to an outlet conduit. The overflow structure consists of a concrete riser pipe with an inlet elevation of +342.5. The riser diameters are 30-in. and 42-in. in the north and south cells respectively.

Access to the overflow structure is provided by a steel framed bridge (See Figure 5.3.1-1).



Figure 5.3.3-1: Access Bridge to Riser Structure; Bottom Ash Pond South Cell

The pipe along the top of the access bridge is the HDPE pipe that can be connected to a mobile pump for transferring water between pond cells.

5.3.2 Outlet Conduit

The north and south cells of the Bottom Ash Pond each have a concrete pipe through the embankment to a valve chamber near the exterior toe of the embankment. The valves direct the discharge back to the plant for recycling.

The HDPE pipe located in the outlet access bridge was installed to facilitate transferring water between the north and south cells. Temporary, mobile pumps can be connected to the pipes as operational conditions require. Dewberry was informed that transfer of water between cells is not done on a regular basis.

5.3.3 Emergency Spillway

The Bottom Ash Pond does not have an emergency spillway. In the event of an emergency, a temporary, mobile pump would be used to pump water from the impoundment to the plant cooling water discharge canal located to the south.

5.3.4 Low Level Outlet

The Bottom Ash Pond does not have a low level outlet.

6.0 HYDROLOGIC/HYDRAULIC SAFETY

6.1 SUPPORTING TECHNICAL DOCUMENTATION

6.1.1 Flood of Record

No documentation has been provided about the flood of record.

6.1.2 Inflow Design Flood

According to FEMA Federal Guidelines for Dam Safety, the current practice in the design of dams is to use the Inflow Design Flood (IDF) that is deemed appropriate for the hazard potential of the dam and reservoir, and to design spillways and outlet works that are capable of safely accommodating the flood flow without risking the loss of the dam or endangering areas downstream from the dam to flows greater than the inflow. The recommended IDF or spillway design flood for a low hazard, small-sized structure (See section 2.2) in accordance with the USACE Recommended Guidelines for Safety Inspection of Dams ER 1110-2-106 criteria is the 50 to 100 year storm (See Table 6.1.2).

| Hazard | Size | Spillway Design Flood |
|---------------|--------------|------------------------------|
| Low | Small | 50- to 100-year frequency |
| | Intermediate | 100-year to ½ PMF |
| | Large | ½ PMF to PMF |
| Significant | Small | 100-year to ½ PMF |
| | Intermediate | ½ PMF to PMF |
| | Large | PMF |
| High | Small | ½ PMF to PMF |
| | Intermediate | PMF |
| | Large | PMF |

No hydrologic and hydraulic documentation was provided to Dewberry for review.

A brief internet search by Dewberry found data from indicating the one percent probability in any given year (100-year storm) 24- hour precipitation in Freestone County, Texas is 10.6 inches (www.onlinemanuals.txdot.gov/txdotmanuals/hyd/p24lkup.xls).

FINAL

6.1.3 Spillway Rating

The Bottom Ash Pond does not have a spillway discharge. The method of discharge from the impoundment is recirculation pumping from risers and conduits through the embankment of each cell to recycle water to the plant.

6.1.4 Downstream Flood Analysis

No downstream flood analysis was provided.

6.2 ADEQUACY OF SUPPORTING TECHNICAL DOCUMENTATION

Supporting documentation from the utility and reviewed by Dewberry is inadequate since no hydrologic and hydraulic safety analyses were provided. However, national rainfall data available to Dewberry is sufficient to determine whether the impoundment is safe from floods and overflows.

6.3 ASSESSMENT OF HYDROLOGIC/HYDRAULIC SAFETY

The crest elevation of the Bottom Ash Pond is a minimum of 8 feet above the adjacent exterior grade. Stormwater into the impoundment is expected to be limited to direct rainfall.

The normal pool elevation of the Bottom Ash Pond is managed to a relatively constant +347 feet, providing a 3-ft. freeboard. The freeboard should be adequate to contain the one-percent probability, 24-hour precipitation event (10.6 inches) without overtopping the impoundment embankments.

7.0 STRUCTURAL STABILITY

7.1 SUPPORTING TECHNICAL DOCUMENTATION

7.1.1 Stability Analyses and Load Cases Analyzed

Subsequent to Dewberry's Draft report submittal, Luminant provided slope stability analyses for the Ash Pond (See Doc 08 in Appendix C).

Slope stability analyses were performed using the commercial slope stability software program, SLIDE Version 6.0. The typical containment dike section has an interior (wet side) slope of 2.5 horizontal to 1 vertical (2.5H:1V) and a minimum exterior (dry side) slope of 2H:1V. The crest elevation of the containment dike is at approximately 350 ft-msl. The ponds are lined with 3 feet of compacted clay. The top of liner elevation on the pond floors is approximately 328 ft-msl. The most critical slope geometry was identified along the west sideslope, consisting of an approximately 24-foot high, 1.7H:1V slope.

Stability analyses were performed for four (4) separate slope sections to assess the various soil conditions and slope geometries around the ponds. Stability analyses considered "empty pond" and "full pond" conditions.

A rapid drawdown scenario was analyzed for one full pond condition at each section. The analysis was completed on the drained or undrained section with the lower factor of safety in the full condition. The analysis was completed using the B-bar method to simulate the effects of rapid drawdown in a low permeability material such as the sandy clays and clayey sands encountered at Big Brown. The initial water level was modeled as the full condition and the final water level was modeled at the pond floor, representing a final condition after drawdown where the pond is empty.

The most critical slope geometry was identified along the east sideslope. The effect of pseudo-static¹ earthquake loading was also analyzed at this location. The plant is not located in a seismic zone (Reference: Figure 6 of EM 1110-2-1902, "Stability of Earth and Rock-Fill Dams", U.S. Army

¹ The pseudostatic method is a simplified method for determining seismic slope stability that is based on the same approach (i.e., limit equilibrium) used in analyzing static slope stability. In current practice, the pseudostatic method of analysis is used primarily as a screening tool to help assess whether an embankment dam or slope requires a more detailed seismic slope analysis. The pseudostatic method ignores cyclic loading of the earthquake, but accounts for seismicity by applying an equivalent static force on the slope. In the limit equilibrium approach bearing capacity and stress-strain relationship of the soil is not considered, so the method should not be used for sensitive clays and other materials that lose shear strength during an earthquake or loose soils located below the groundwater table subject to liquefaction.

FINAL

Corps of Engineers, 1970), so a nominal seismic coefficient of 0.01g was therefore used in the earthquake loading analysis.

7.1.2 Design Parameters and Dam Materials

The Golder Associates report, Ash Pond Slope Stability Investigation Report (See Appendix C – Doc 08) included design parameters and dam material information used for modeling structural stability. Table 7.1 presents parametric values for impoundment materials from the report that were used in the stability analyses

| Soil Material | Moist Unit Weight (lb/ft ³) | Saturated Unit Weight (lb/ft ³) | Undrained Soil Properties | | Drained Soil Properties | |
|------------------------|---|---|---|---------------------------|--------------------------------------|---------------------------|
| | | | Undrained Shear Strength, s_u (lb/ft ²) | Friction Angle ϕ (°) | Cohesion, c' (lb/ft ²) | Friction Angle ϕ (°) |
| Sandy Clay/Clayey Sand | 127 | 132 | 1500 | 0 | 1000 | 14 |
| Clean Sand | 127 | 132 | 0 | 29 | 0 | 29 |

7.1.3 Uplift and/or Phreatic Surface Assumptions

No documentation of uplift force or phreatic surface assumptions was provided to Dewberry for review.

7.1.4 Factors of Safety and Base Stresses

Slope stability analyses were performed for both short-term and long-term conditions using undrained and drained soil properties, respectively. The results of the analyses are provided in Table 7.2. A factor of safety of 1.5 is typically considered adequate for permanent slopes. The minimum calculated factor of safety from our analyses is 2.5 (Case 2) for normal loading conditions. The analyses indicate that the slopes are stable. Additionally, slope stability analyses for rapid drawdown and earthquake conditions have factors of safety greater than 1.5 as well.

FINAL

TABLE 7.2 SLOPE STABILITY FACTORS OF SAFETY

| Case | Description | Factor of Safety | Inside/outside slope |
|------|--|------------------|----------------------|
| 1 | East sideslope; empty pond; short-term (undrained) conditions | 2.6 | Inside |
| 2 | East sideslope; empty pond; long-term (drained) conditions | 2.5 | Inside |
| 3 | East sideslope; full pond; short-term (undrained) conditions | 5.7 | Inside |
| 4 | East sideslope; full pond; long-term (drained) conditions | 5.9 | Inside |
| 5 | East sideslope; empty pond; long-term conditions; seismic , earthquake loading analysis | 2.4 | Inside |
| 6 | East sideslope; rapid drawdown | 2.6 | Inside |
| 7 | North sideslope; empty pond; short-term (undrained) conditions | 3.3 | Inside |
| 8 | North sideslope; empty pond; long-term (drained) conditions | 3.2 | Inside |
| 9 | North sideslope; full pond; short-term (undrained) conditions | 6.3 | Inside |
| 10 | North sideslope; full pond; long-term (drained) conditions | 6.6 | Inside |
| 11 | North sideslope; rapid drawdown | 3.1 | Inside |
| 12 | Northeast sideslope; empty pond; short-term (undrained) conditions | 3.5 | Outside |
| 13 | Northeast sideslope; empty pond; long-term (drained) conditions | 3.6 | Outside |
| 14 | Northeast sideslope; full pond; short-term (undrained) conditions | 3.5 | Outside |
| 15 | Northeast sideslope; full pond; long-term (drained) conditions | 3.6 | Outside |
| 16 | Northeast sideslope; rapid drawdown | 3.6 | Outside |
| 17 | West sideslope; empty pond; short-term (undrained) conditions | 5.5 | Outside |
| 18 | West sideslope; empty pond; long-term (drained) conditions | 4.4 | Outside |
| 19 | West sideslope; full pond; short-term (undrained) conditions | 5.4 | Outside |
| 20 | West sideslope; full pond; long-term (drained) conditions | 4.4 | Outside |
| 21 | West sideslope; rapid drawdown | 4.4 | Outside |

US EPA ARCHIVE DOCUMENT

FINAL

7.1.5 Liquefaction Potential

The soils encountered in the borings are not susceptible to liquefaction.

The 2008 U.S.G.S. seismic risk map indicates the estimated peak ground acceleration for an earthquake having a two percent probability of exceedance in 50 years is 0.04g.

7.1.6 Critical Geological Conditions

Critical geologic conditions were determined from maps in the *Geologic Atlas of Texas*, accessed on the Texas Water Development Board website.² The sequence of geologic formations from the surface included the Calvert Bluff, Simsboro, and Hooper formations.

The Calvert Bluff formation includes sandy to silty clays between seams of lignite. The lignite is surface mined to provide fuel for the Big Brown SES. The thickness of the Calvert Formation is several hundred feet. The Calvert Bluff Formation is underlain by the Simsboro Formation consisting of well-sorted fine to coarse sand with lenses of mudstone. The Hooper formation which underlies the Simsboro Formation consists of mudstone and sandstone.

7.2 ADEQUACY OF SUPPORTING TECHNICAL DOCUMENTATION

Subsequent to Dewberry's Draft report submittal, Luminant provided slope stability analyses for the Ash Pond (See Doc 08 in Appendix C). Based on the new information provide the structural stability documentation is adequate to support a quantitative analysis of the stability of the embankments impounding the Bottom Ash Pond.

7.3 ASSESSMENT OF STRUCTURAL STABILITY

Overall, the structural stability of the Bottom Ash Pond embankment appears to be **Satisfactory** based on the following observations:

- Safety factors for static stability and seismic stability meet the minimum required by the US Army Corp of Engineers guidance.

² Texas Water Development Board web site: www.txwb.state.tx.us/groundwater/acquifer/GAT/

FINAL

8.0 ADEQUACY OF MAINTENANCE AND METHODS OF OPERATION

8.1 OPERATING PROCEDURES

Dehydrated bottom ash and boiler slag are collected in dewatering bins and transported off-site for beneficial re-use or land disposal as solid waste.. The Bottom Ash Pond also receives process water and precipitation runoff (See Appendix A –Doc 6). There are dedicated pipes feeding each the north and south cells of the impoundment. Sluiced ash is piped to the east end of each cell. Sluice water is recycled through a decant riser at the west end of each cell. The outlet pipes connect to a valve box near the exterior toe of the south cell. Standard operating procedures are for the valves to route water back to the plant for recycling. In the event of unexpected conditions, the valves are reset to send water to a Bottom Ash Treatment Pond, which is the TXPDES permitted outfall for the plant.

Water transfer between pond cells is not a frequent event, but when required it is accomplished using a temporary mobile pump and HDPE pipes attached to the top of the decant riser system access bridge.

Emergency drainage of the Bottom Ash Pond is conducted using mobile pumps and discharging water to the plant discharge canal near the south side of the impoundment.

8.2 MAINTENANCE OF THE DAM AND PROJECT FACILITIES

Maintenance of the impoundment generally consists of mowing the exterior slopes and toe areas, periodic grading of the crest, and repairing anomalies reported in weekly inspection reports.

8.3 ASSESSMENT OF MAINTENANCE AND METHODS OF OPERATIONS

8.3.1 Adequacy of Operating Procedures

Based on assessments from received documents and the site visit, operating procedures appear to be adequate.

8.3.2 Adequacy of Maintenance

Based on assessments from received documents and the site visit, maintenance procedures appear to be adequate.

FINAL

9.0 ADEQUACY OF SURVEILLANCE AND MONITORING PROGRAM

9.1 SURVEILLANCE PROCEDURES

Normal plant surveillance procedures consist of weekly visual inspections of the Bottom Ash Pond. Results of the inspections are recorded on checklist reports and submitted to plant management.

Critical impoundment inspections are conducted annually, either by Luminant corporate technical staff, or outside technical consultants. Dewberry was provided copies of the February 2011 and April 2012 inspection reports prepared by engineers from the Luminant Fossil Engineering and Support group, and HDR Engineering, Inc. respectively (See Appendix A – Docs 3 and 4, respectively).

Although both reports included recommendations for relatively minor maintenance actions, no major concerns were identified. Findings in both reports were consistent with Dewberry's observations during our site visit.

9.2 INSTRUMENTATION MONITORING

Instrumentation of the embankment consists of groundwater piezometers located outside the toe of the perimeter embankment (See Figure 9.2-1). The piezometers are read semi-annually and results reported to plant management.



**Figure 9.2-1: Piezometer near Embankment Toe
– Northwest Groin**

FINAL

9.3 ASSESSMENT OF SURVEILLANCE AND MONITORING PROGRAM

9.3.1 Adequacy of Inspection Program

Based on the data reviewed by Dewberry, including observations during the site visit, the inspection program is adequate.

9.3.2 Adequacy of Instrumentation Monitoring Program

Based on the data reviewed by Dewberry, including observations during the site visit, the monitoring program is adequate.

APPENDIX A

Document 1

Bottom Ash Pond Design Drawing

119-1134-301 Sheets 1 - 3

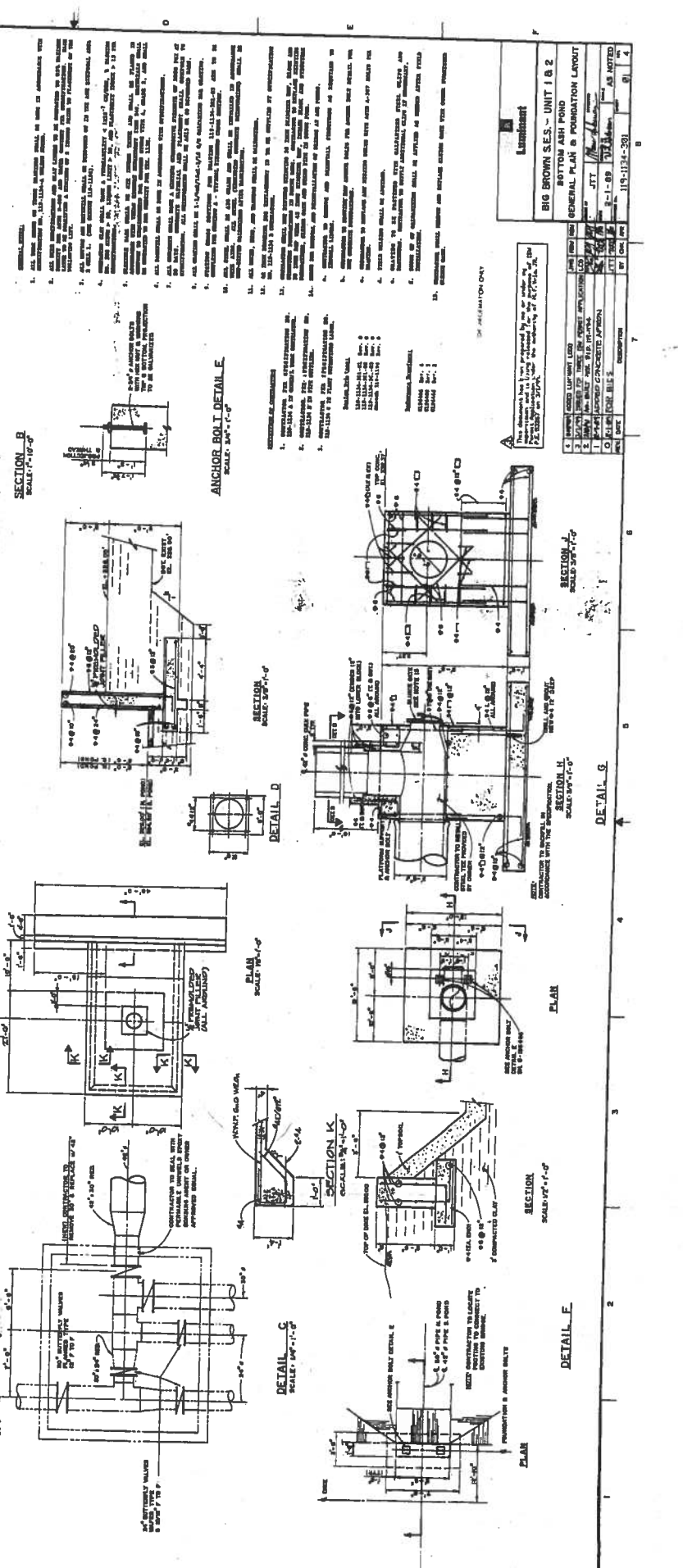
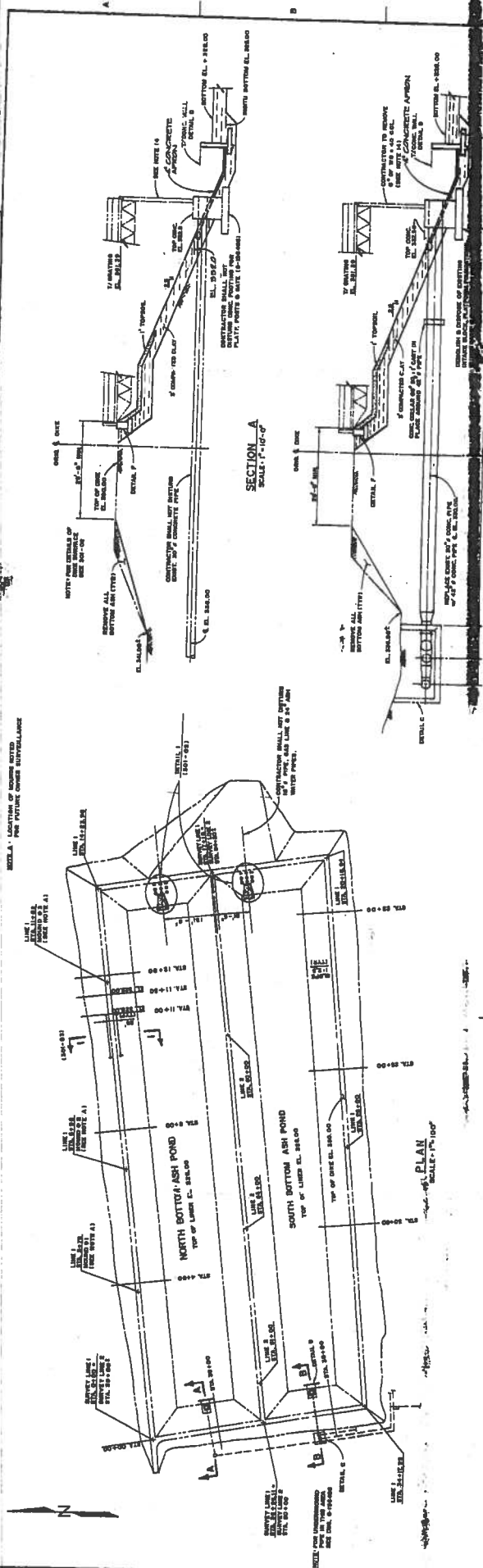

- GENERAL NOTES:**
1. ALL STRUCTURAL STEEL SHALL BE A36 UNLESS OTHERWISE SPECIFIED.
 2. ALL STRUCTURAL STEEL SHALL BE WELDED TO THE CONCRETE SLAB.
 3. ALL STRUCTURAL STEEL SHALL BE WELDED TO THE CONCRETE SLAB.
 4. ALL STRUCTURAL STEEL SHALL BE WELDED TO THE CONCRETE SLAB.
 5. ALL STRUCTURAL STEEL SHALL BE WELDED TO THE CONCRETE SLAB.
 6. ALL STRUCTURAL STEEL SHALL BE WELDED TO THE CONCRETE SLAB.
 7. ALL STRUCTURAL STEEL SHALL BE WELDED TO THE CONCRETE SLAB.
 8. ALL STRUCTURAL STEEL SHALL BE WELDED TO THE CONCRETE SLAB.
 9. ALL STRUCTURAL STEEL SHALL BE WELDED TO THE CONCRETE SLAB.
 10. ALL STRUCTURAL STEEL SHALL BE WELDED TO THE CONCRETE SLAB.
 11. ALL STRUCTURAL STEEL SHALL BE WELDED TO THE CONCRETE SLAB.
 12. ALL STRUCTURAL STEEL SHALL BE WELDED TO THE CONCRETE SLAB.
 13. ALL STRUCTURAL STEEL SHALL BE WELDED TO THE CONCRETE SLAB.
 14. ALL STRUCTURAL STEEL SHALL BE WELDED TO THE CONCRETE SLAB.
 15. ALL STRUCTURAL STEEL SHALL BE WELDED TO THE CONCRETE SLAB.

Legend

| | | |
|----|------------|------------|
| 1 | CONCRETE | CONCRETE |
| 2 | STEEL | STEEL |
| 3 | WOOD | WOOD |
| 4 | PAINT | PAINT |
| 5 | ASPHALT | ASPHALT |
| 6 | GRAVEL | GRAVEL |
| 7 | SAND | SAND |
| 8 | CLAY | CLAY |
| 9 | ROCK | ROCK |
| 10 | WATER | WATER |
| 11 | AIR | AIR |
| 12 | SOIL | SOIL |
| 13 | ICE | ICE |
| 14 | SNOW | SNOW |
| 15 | VEGETATION | VEGETATION |

Legend

| | | |
|----|------------|------------|
| 1 | CONCRETE | CONCRETE |
| 2 | STEEL | STEEL |
| 3 | WOOD | WOOD |
| 4 | PAINT | PAINT |
| 5 | ASPHALT | ASPHALT |
| 6 | GRAVEL | GRAVEL |
| 7 | SAND | SAND |
| 8 | CLAY | CLAY |
| 9 | ROCK | ROCK |
| 10 | WATER | WATER |
| 11 | AIR | AIR |
| 12 | SOIL | SOIL |
| 13 | ICE | ICE |
| 14 | SNOW | SNOW |
| 15 | VEGETATION | VEGETATION |

Legend

| | | |
|----|------------|------------|
| 1 | CONCRETE | CONCRETE |
| 2 | STEEL | STEEL |
| 3 | WOOD | WOOD |
| 4 | PAINT | PAINT |
| 5 | ASPHALT | ASPHALT |
| 6 | GRAVEL | GRAVEL |
| 7 | SAND | SAND |
| 8 | CLAY | CLAY |
| 9 | ROCK | ROCK |
| 10 | WATER | WATER |
| 11 | AIR | AIR |
| 12 | SOIL | SOIL |
| 13 | ICE | ICE |
| 14 | SNOW | SNOW |
| 15 | VEGETATION | VEGETATION |

Legend

| | | |
|----|------------|------------|
| 1 | CONCRETE | CONCRETE |
| 2 | STEEL | STEEL |
| 3 | WOOD | WOOD |
| 4 | PAINT | PAINT |
| 5 | ASPHALT | ASPHALT |
| 6 | GRAVEL | GRAVEL |
| 7 | SAND | SAND |
| 8 | CLAY | CLAY |
| 9 | ROCK | ROCK |
| 10 | WATER | WATER |
| 11 | AIR | AIR |
| 12 | SOIL | SOIL |
| 13 | ICE | ICE |
| 14 | SNOW | SNOW |
| 15 | VEGETATION | VEGETATION |

Legend

| | | |
|----|------------|------------|
| 1 | CONCRETE | CONCRETE |
| 2 | STEEL | STEEL |
| 3 | WOOD | WOOD |
| 4 | PAINT | PAINT |
| 5 | ASPHALT | ASPHALT |
| 6 | GRAVEL | GRAVEL |
| 7 | SAND | SAND |
| 8 | CLAY | CLAY |
| 9 | ROCK | ROCK |
| 10 | WATER | WATER |
| 11 | AIR | AIR |
| 12 | SOIL | SOIL |
| 13 | ICE | ICE |
| 14 | SNOW | SNOW |
| 15 | VEGETATION | VEGETATION |

Legend

| | | |
|----|------------|------------|
| 1 | CONCRETE | CONCRETE |
| 2 | STEEL | STEEL |
| 3 | WOOD | WOOD |
| 4 | PAINT | PAINT |
| 5 | ASPHALT | ASPHALT |
| 6 | GRAVEL | GRAVEL |
| 7 | SAND | SAND |
| 8 | CLAY | CLAY |
| 9 | ROCK | ROCK |
| 10 | WATER | WATER |
| 11 | AIR | AIR |
| 12 | SOIL | SOIL |
| 13 | ICE | ICE |
| 14 | SNOW | SNOW |
| 15 | VEGETATION | VEGETATION |

119-1134-301 03

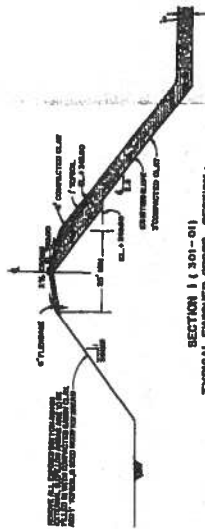
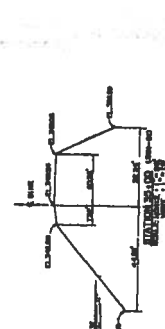
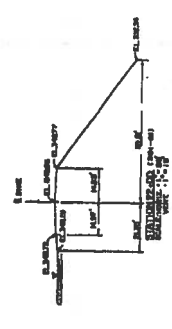
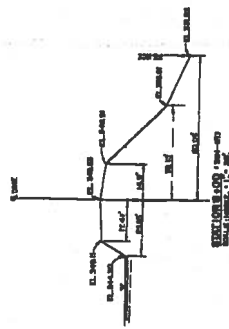

SECTION 1 (301-01)
TYPICAL FINISHED BRIDGE SECTION

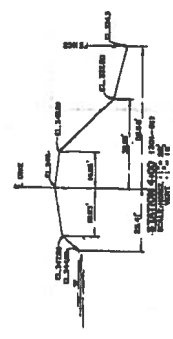
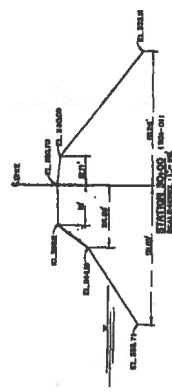
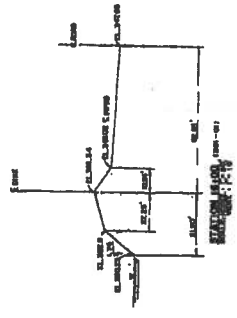
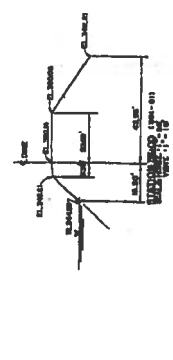
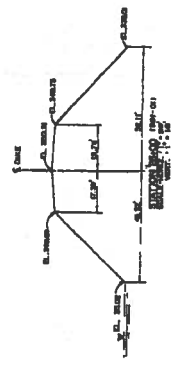
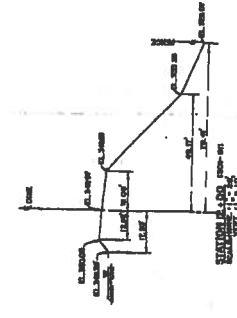

NOTES:
1. SEE GENERAL NOTES AND SPEC. 801-01

This document has been prepared by the number of the project and the name of the project. The drawing is the property of the State of California and shall not be used for any other project without the written consent of the State of California.

| | |
|-------------------------------|--------------|
| 119-1134-301 | |
| Landsheet | |
| BIG BROWN S.E. UNITS 1, 2 & 3 | |
| BOTTOM ASH POND | |
| DATE | 11-1-88 |
| BY | W. J. ... |
| CHECKED BY | ... |
| SCALE | AS SHOWN |
| PROJECT NO. | 119-1134-301 |
| SHEET NO. | 03 |
| TOTAL SHEETS | 3 |

| NO. | DESCRIPTION | DATE | BY | CHECKED |
|-----|-------------------------|---------|-----------|---------|
| 1 | ISSUED FOR PERMITS | 11-1-88 | W. J. ... | ... |
| 2 | ISSUED FOR CONSTRUCTION | ... | ... | ... |
| 3 | ISSUED FOR RECORD | ... | ... | ... |

119-1134-301

APPENDIX A

Document 2

Big Brown Bottom Ash Pond Weekly Inspection Reports for September 6 and 11, 2012

BIG BROWN STEAM ELECTRIC STATION

Bottom Ash Pond Inspection

Inspected by: McNew

Date of Inspection: 9-6-12

Permit No. SW-39099

| Yes | No | Item | Deficiencies | Date Corrected |
|-------------------------------------|-------------------------------------|---|--------------|----------------|
| | <input checked="" type="checkbox"/> | Visible leaks or corrosion associated with transfer piping for metal cleaning waste. | | |
| <input checked="" type="checkbox"/> | | Freeboard is a minimum of 3 feet. <u>Nth. Pond Elevation --> 347</u> <u>Sth. Pond Elevation --> 347</u> | | |
| | <input checked="" type="checkbox"/> | Evidence of overtopping of dikes. | | |
| | <input checked="" type="checkbox"/> | Depressions, potholes. Or Washouts in flexbase of truck ramp or on top of containment dike. | | |
| | <input checked="" type="checkbox"/> | Visible signs of erosion along external or internal slopes of containment dike. | | |
| | <input checked="" type="checkbox"/> | Bare spots in vegetative cover along external slope of dike. | | |
| | <input checked="" type="checkbox"/> | Trees, brush, or other plants with root systems capable of penetrating clay liner. | | |
| <input checked="" type="checkbox"/> | <input checked="" type="checkbox"/> | WMU signs prominently displayed. | | |
| | <input checked="" type="checkbox"/> | Evidence of tank truck or piping spills/leaks. | | |

Maintain completed form with the WMC Compliance Plan for a period of three (3) years.

FOR USE BY WMC ONLY

BIG BROWN STEAM ELECTRIC STATION

Bottom Ash Pond Inspection

Inspected by: McNew

Date of Inspection: 9-11-12

Permit #: SW-39099

| Yes | No | Item | Deficiencies | Date Corrected |
|-------------------------------------|-------------------------------------|---|--------------|----------------|
| | <input checked="" type="checkbox"/> | Visible leaks or corrosion associated with transfer piping for metal cleaning waste. | | |
| <input checked="" type="checkbox"/> | | Freeboard is a minimum of 3 feet. N th Pond Elevation --> 346.8 S th Pond Elevation --> 347 | | |
| | <input checked="" type="checkbox"/> | Evidence of overtopping of dikes. | | |
| | <input checked="" type="checkbox"/> | Depressions, potholes. Or Washouts in flexbase of truck ramp or on top of containment dike. | | |
| | <input checked="" type="checkbox"/> | Visible signs of erosion along external or internal slopes of containment dike. | | |
| | <input checked="" type="checkbox"/> | Bare spots in vegetative cover along external slope of dike. | | |
| | <input checked="" type="checkbox"/> | Trees, brush, or other plants with root systems capable of penetrating clay liner. | | |
| <input checked="" type="checkbox"/> | | WMU signs prominently displayed. | | |
| | <input checked="" type="checkbox"/> | Evidence of tank truck or piping spills/leaks. | | |

Maintain completed form with the WMC Compliance Plan for a period of three (3) years.

FOR INFORMATION ONLY

APPENDIX A

Document 3

Big Brown Critical Impoundment Inspection Report, Luminant Fossil Engineering Services, February 21, 2011

Critical Impoundment Inspection Report

For

Big Brown SES

The attached report is based on an on-site inspection conducted on January 17, 2011 at Luminant's Big Brown Steam Electric Station located in Freestone County, Texas.

Draft Report date: February 3, 2011

Final report date: February 20, 2011

Added PE Seal: February 21, 2011



FOR INFORMATION ONLY

Mark W. Kelly
February 21, 2011

Report prepared by: Mark W. Kelly, P.E.

Luminant

500 N. Akard St., Dallas, TX 75201
Office: 214-875-8259 ◊ Fax: 214-875-8284
Email: mark.kelly@luminant.com

Table of Contents:

Introduction

Pond Impoundment Inspections:

- North and South Bottom Ash Ponds
- Plant Operating Pond
- Storm Drain Pond
- Inactive Solid Waste Disposal Area

Appendix A – Critical Impoundment Worksheets:

- North Bottom Ash Pond
- South Bottom Ash Ponds
- Plant Operating Pond
- Storm Drain Pond
- Inactive Solid Waste Disposal Area

Appendix B –Photo Locator Plans:

- SK-1 Bottom Ash Pond 2010 Inspection Photo Locator Plan
- SK-2 Plant Operating Pond 2010 Inspection Photo Locator Plan
- SK-3 Storm Drain Pond 2010 Inspection Photo Locator Plan
- SK-4 Inactive Solid Waste Disposal Area 2010 Inspection Photo Locator Plan

Introduction:

The critical impoundments at Big Brown SES were inspected for dike structural stability on January 17, 2011. The inspection was performed by Mark W. Kelly of Luminant Fossil Engineering Services and Will Steen of Luminant Big Brown SES. As shown on Figure 1, the impoundments inspected were: North Bottom Ash Pond, South Bottom Ash Pond, Plant Operating Pond, Storm Drain Pond and the Inactive Waste Disposal Area.

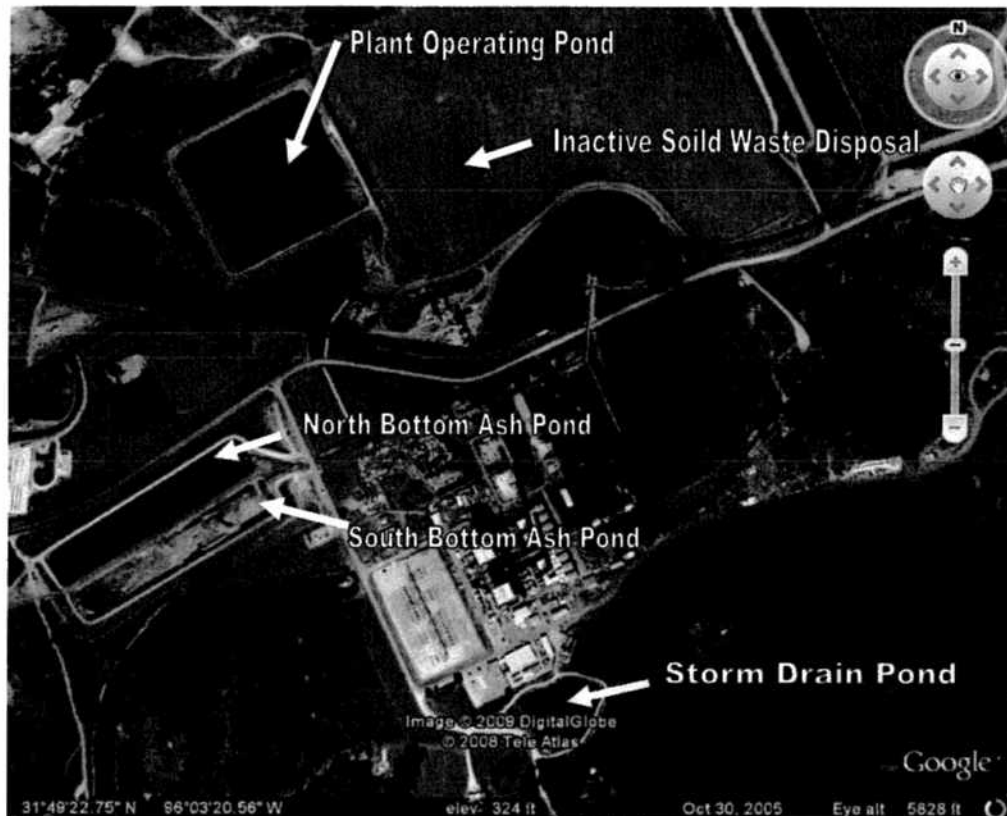

Figure 1: Big Brown Steam Electric Station Site Impoundments

The site had two days of rain fall prior to the inspection in the amounts of 1.15-in and 2.30-in on January 15th and 16th, 2011 respectively. At the time of inspection, the ground was moist with standing water in various locations.

Worksheets and photo location drawings for all impoundment inspections are included in Appendices A and B of this report.

The inspection of Big Brown's critical impoundments included a visual inspection of the inner and outer berms and crest for vegetative cover, erosion, misalignment, slides, settlement, damage and erosion, seeps, cracks, and lining condition.

North and South Bottom Ash Ponds:

The North and South Bottom Ash Ponds are adjacent to each other. They are clay-lined surface impoundments used to hold metal-cleaning wastes, waste water treatment wastes, and bottom ash contained in transporter sluice water. The rectangular impoundments measure approximately 1,400 feet by 264 feet at the crest. Each pond surface area is 9.6 acres. The slope of the dike is approximately 1:2.5, and the depth of the impoundments from the top of the dike to the top of the clay liner is 22 feet. Each pond will hold about 44 million gallons when the fluid level is at the top of the dike or about 38 million gallons (or 114 acre-feet) with 3 feet of freeboard.

Each impoundment is constructed with a compacted clay liner 3 feet thick underlying the bottom and interior dike slopes. The clay liner does not extend beyond the centerline of the crest.

The top of the dikes is approximately 14 to 21 feet above the surrounding grade. Surface runoff does not enter the impoundments.

On inspection day, the water elevations of South and North Bottom Ash Ponds were 347.0-feet. In 2010 both impoundments had their upstream slopes repaired and Recyclax erosion placed along the perimeter approximately 3-feet below and above the waterline. The Recyclax on the South Pond had been in place for 12 months at the time of the inspection and was found to be in good condition the vegetation is well established. The erosion protection at the North Pond had been in place approximately 4 months prior and was also performing well with the exception with one area. On the west side there was a gully that has formed where the vegetation was not able to establish. This needs to be filled in and re-vegetated. The other major item noted is the extensive hog damage along the downstream slope on the south side of the South Pond. This should be smoothed out and reseeded to promote vegetation to take hold and prevent erosion. There are two minor action items identified including rutting at various locations on the crest and a few bean sprouts on the south side of the upstream embankment of the South Pond.

Photo locations in this report can be found in Appendix B on SK-1 "Bottom Ash Pond 2011 Inspection Photo Locator Plan."

Photos 1 and 2 show the Recyclax along the upstream slopes. Photo 1 is representative of the South Pond where the vegetation has been established. The North Pond (Photo 2) depicts the Recyclax on the North Pond where the vegetation is not widely established. This should take hold once the spring growth season starts.

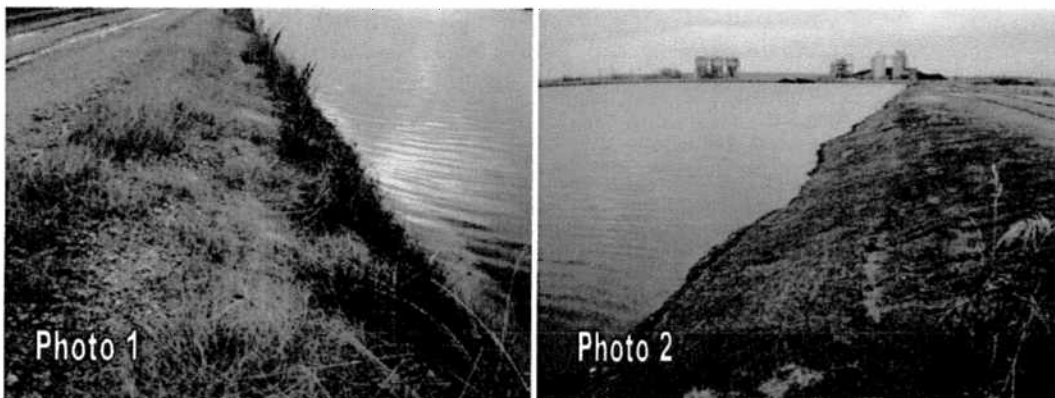

Photos 3 and 4 show the two locations on the north side of the North Pond where erosion has occurred under the Recyclex. It is recommended these areas be filled in and allowed to re-vegetate.

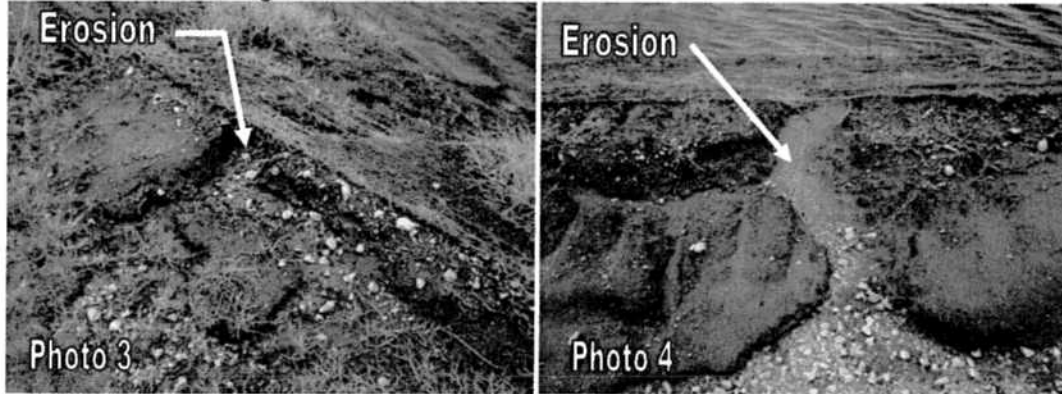

Photos 5 and 6 depict the hog damage that was prevalent along the downstream embankment of the South Pond. This needs to be re-vegetated to prevent erosion.

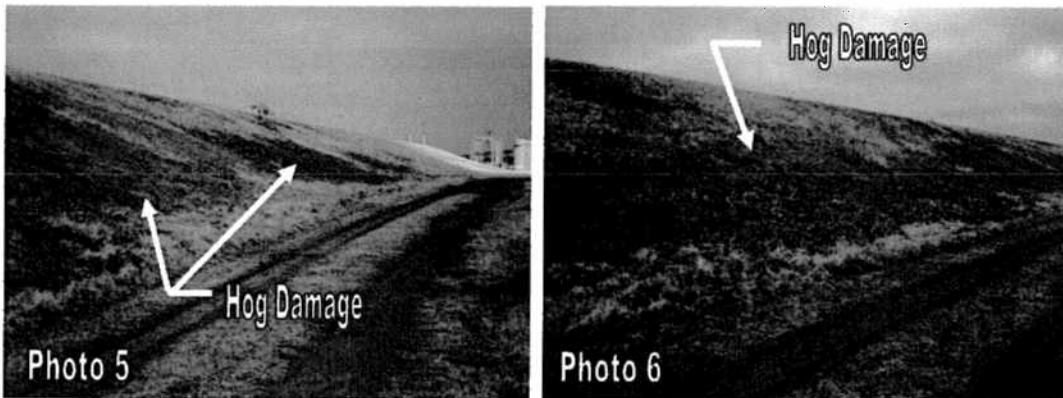
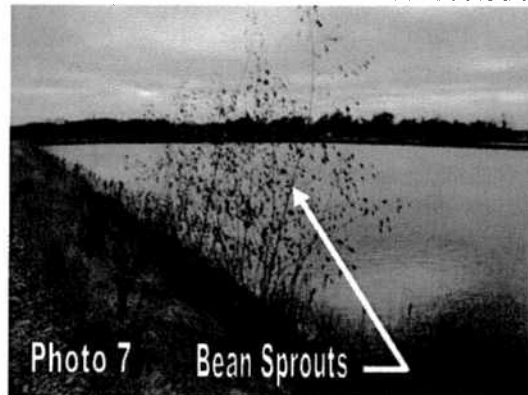

Photo 7 shows bean sprouts on the center of the upstream embankment of the South Pond. This needs to be removed at the next routine scheduled maintenance.



Photos 8 and 9 are rutting along the crest. The ruts allow rainwater to collect, penetrate and potentially weaken the embankment. These should be repaired and care should be taken to avoid driving on the crest when the embankment has been softened by wet conditions. See SK-1 for the locations of the ruts.



Plant Operating Pond:

The Plant Operating Pond is located north of the plant near the Boral facilities.

The square Plant Operating Pond measures approximately 800 feet by 800 feet at the crest and is 24 feet deep. Surface area is approximately 14.7 acres. The pond capacity is about 83 million gallons. On the day of the inspection the pond level was recorded at 322.4-feet.

The impoundment is constructed with a 3-foot thick compacted clay liner underlying the bottom and interior dike slopes. The clay liner does not extend beyond the centerline of the crest. Riprap has been placed at the upstream corners and along the east end of the pond.

The top of the dike is above the surrounding grade on all sides. Surface runoff does not enter the impoundments.

Photo locations in this report can be found in Appendix B on SK-2 "Plant Operating Pond 2010 Inspection Photo Locator Plan."

Following are the observations with recommendations:

Rutting was absent from most of the crest except one location on the south east side where the rutting was deep and a large amount of water had collected. (Photo 1) This should be corrected as soon as possible as this water will penetrate and potentially weaken the embankment. Whenever possible, care should be taken to avoid driving on the embankment periods when the embankment is soft as a result of wet conditions.

PAGE (S) REMOVED

NOT IN SCOPE

APPENDIX A
INSPECTION WORKSHEETS

CRITICAL IMPOUNDMENT INSPECTION CHECKLIST

| Impoundment: North Bottom Ash Pond | | | Inspection Date: January 17, 2011 | | | | Weather: Cloudy and Cool | | | |
|--|------|----------------------|--|-----------------------------|----------|--------------|--------------------------|--------|---------|--------|
| Inspected By: Mark Kelly | | | Last Inspection Date: February 1, 2010 | | | | | | | |
| Area | Item | Condition | Current Observations | Change From Last Inspection | | | | Action | | |
| | | | | Similar | Improved | Deteriorated | unknown | OK | Monitor | Repair |
| CREST | 1 | SURFACE CRACKING | Non Observed | X | | | | X | | |
| | 2 | ANIMAL BURROWS | Non Observed | X | | | | X | | |
| | 3 | CREST SINKS | Non Observed | X | | | | X | | |
| | 4 | HORIZONTAL ALIGNMENT | Good | X | | | | X | | |
| | 5 | RUTS/PUDDLES | Some ruts on the west side | | X | | | | | X |
| | 6 | VEGETATION | Grass on the edges and no vegetation on the driving surface. | X | | | | X | | |
| | 7 | TREES | Non Observed | X | | | | X | | |
| | 8 | CREST - OTHER | Non Observed | X | | | | X | | |
| | 9 | | | | | | | | | |
| | 10 | | | | | | | | | |
| UPSTREAM EMBANKMENT | 11 | TREES | Not Applicable | X | | | | X | | |
| | 12 | BERM SLIDE, SLOUGH | Repaired during the Fall of 2010. | | X | | | X | | |
| | 13 | SLOPE PROTECTION | Recyclax with Grass | | X | | | X | | |
| | 14 | BERM SINKS | Non Observed | X | | | | X | | |
| | 15 | ANIMAL BURROWS | Non Observed | X | | | | X | | |
| | 16 | ABUTMENT CONTACT | Good | X | | | | X | | |
| | 17 | EROSION | Two areas on the north side in the center. Improved from 2010. | | X | | | | | X |
| | 18 | VEGETATION | Grass anchored by Recyclax | | X | | | X | | |
| | 19 | TREES | Non Observed | | X | | | X | | |
| | 20 | BERM BULGES | Non Observed | X | | | | X | | |
| | 21 | UPSTREAM - OTHER | Non Observed | X | | | | X | | |
| | 22 | | | | | | | | | |
| | 23 | | | | | | | | | |
| DOWNSTREAM EMBANKMENT | 24 | WET AREAS, SEEPAGE | Non Observed | X | | | | X | | |
| | 25 | EST. SEEPAGE RATE | Non Observed | X | | | | X | | |
| | 26 | SEEPAGE DESCRIPTION | Non Observed | X | | | | X | | |
| | 27 | BERM SLIDE, SLOUGH | Non Observed | X | | | | X | | |
| | 28 | ABUTMENT CONTACT | Good | X | | | | X | | |
| | 29 | ANIMAL BURROWS | Non Observed | X | | | | X | | |
| | 30 | EROSION | Some minor erosion on the NE side. | | X | | | X | | |
| | 31 | UNUSUAL MOVEMENT | Non Observed | X | | | | X | | |
| | 32 | VEGETATION | Grass | X | | | | X | | |
| | 33 | TREES | Non Observed | | | | | | | |
| | 34 | DOWNSTREAM - OTHER | Non Observed | | | | | | | |
| | 35 | | | | | | | | | |
| | 36 | | | | | | | | | |
| | 37 | | | | | | | | | |
| Comments and Photo Information: | | | | | | | | | | |

CRITICAL IMPOUNDMENT INSPECTION CHECKLIST

| Impoundment: South Bottom Ash Pond | | | Inspection Date: January 17, 2011 | | | Weather: Cloudy and Cool | | | | |
|------------------------------------|------|----------------------|--|-----------------------------|----------|--------------------------|---------|--------|---------|--------|
| Inspected By: Mark Kelly | | | Last Inspection Date: February 1, 2010 | | | | | | | |
| Area | Item | Condition | Current Observations | Change From Last Inspection | | | | Action | | |
| | | | | Similar | Improved | Deteriorated | unknown | OK | Monitor | Repair |
| CREST | 1 | SURFACE CRACKING | Non Observed | X | | | | X | | |
| | 2 | ANIMAL BURROWS | Non Observed | X | | | | X | | |
| | 3 | CREST SINKS | Non Observed | X | | | | X | | |
| | 4 | HORIZONTAL ALIGNMENT | Good | X | | | | X | | |
| | 5 | RUTS/PUDDLES | Some ruts on the west side | | X | | | | | X |
| | 6 | VEGETATION | Grass on the edges and no vegetation on the driving surface. | X | | | | X | | |
| | 7 | TREES | Non Observed | X | | | | X | | |
| | 8 | CREST - OTHER | Non Observed | X | | | | X | | |
| | 9 | | | | | | | | | |
| | 10 | | | | | | | | | |
| UPSTREAM EMBANKMENT | 11 | TREES | Not Applicable | X | | | | X | | |
| | 12 | BERM SLIDE, SLOUGH | Repaired during the Fall of 2010. | | X | | | X | | |
| | 13 | SLOPE PROTECTION | Recyclax with Grass | | X | | | X | | |
| | 14 | BERM SINKS | Non Observed | X | | | | X | | |
| | 15 | ANIMAL BURROWS | Non Observed | X | | | | X | | |
| | 16 | ABUTMENT CONTACT | Good | X | | | | X | | |
| | 17 | EROSION | Non Observed | X | | | | X | | |
| | 18 | VEGETATION | Grass anchored by Recyclax | | X | | | X | | |
| | 19 | TREES | Non Observed | | X | | | X | | |
| | 20 | BERM BULGES | Non Observed | X | | | | X | | |
| | 21 | UPSTREAM - OTHER | Bean stalks to be remove don the south side near the center. | | | X | | | | X |
| | 22 | | | | | | | | | |
| | 23 | | | | | | | | | |
| DOWNSTREAM EMBANKMENT | 24 | WET AREAS, SEEPAGE | Non Observed | X | | | | X | | |
| | 25 | EST. SEEPAGE RATE | Non Observed | X | | | | X | | |
| | 26 | SEEPAGE DESCRIPTION | Non Observed | X | | | | X | | |
| | 27 | BERM SLIDE, SLOUGH | Non Observed | X | | | | X | | |
| | 28 | ABUTMENT CONTACT | Good | X | | | | X | | |
| | 29 | ANIMAL BURROWS | Non Observed | X | | | | X | | |
| | 30 | EROSION | Some minor erosion on the NE side. | X | | | | X | | |
| | 31 | UNUSUAL MOVEMENT | Non Observed | X | | | | X | | |
| | 32 | VEGETATION | Grass | X | | | | X | | |
| | 33 | TREES | Non Observed | X | | | | X | | |
| | 34 | DOWNSTREAM - OTHER | Extensive hog damage on the south side. Revegetate. | | | X | | | | X |
| | 35 | | | | | | | | | |
| | 36 | | | | | | | | | |
| | 37 | | | | | | | | | |

Comments and Photo Information:

PAGE (S) REMOVED

NOT IN SCOPE

APPENDIX B
PHOTO LOCATOR PLANS

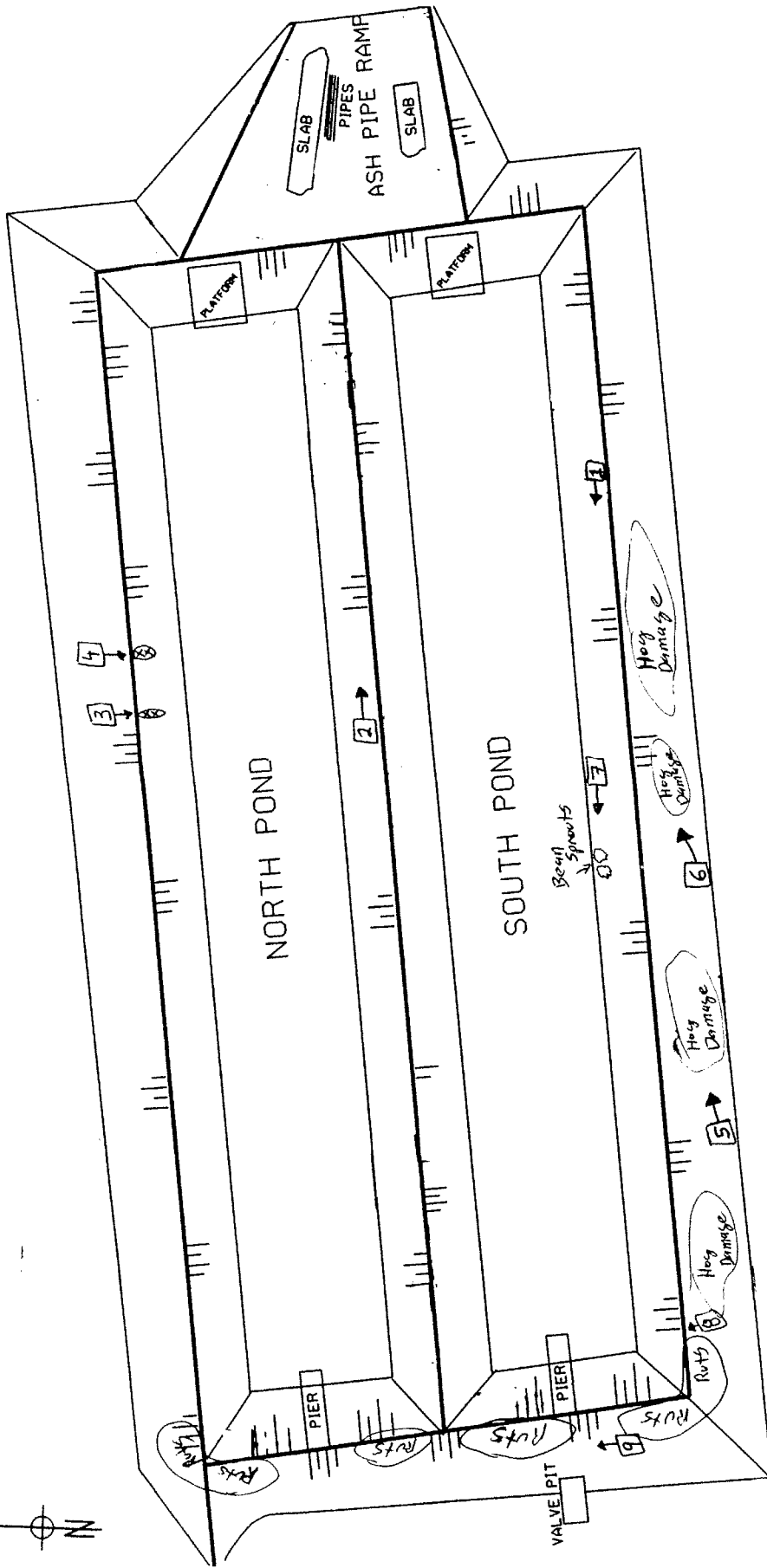

□ → DESIGNATES CAMERA VIEW LOCATION OF PHOTO. NUMBER IN BOX IS NUMBER OF PHOTO.

BIG BROWN SES
SK-1 "BOTTOM ASH POND"
INSPECTION DATE: JANUARY 17, 2011

PAGE (S) REMOVED

NOT IN SCOPE

APPENDIX A

Document 4

Big Brown Critical Impoundment Inspection Report, HDR Engineering Inc., April 19, 2012



Luminant

FOR INFORMATION ONLY

**Big Brown Steam Electric Station
Freestone County, Texas**

Critical Impoundment Inspection Report

April 19, 2012

**HDR Project No. 179596
Texas P.E. Firm Registration No. F-754**

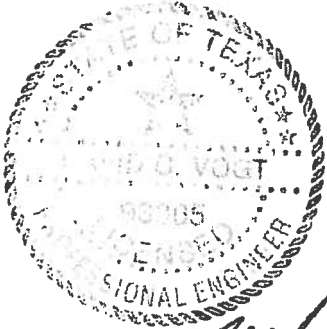

Andrew B. Vogt
4/19/12

Contents

| | |
|---|----|
| Summary of Findings..... | 2 |
| Background..... | 2 |
| North and South Bottom Ash Pond: | 5 |
| Crest..... | 5 |
| Upstream Embankment..... | 6 |
| Downstream Embankment..... | 7 |
| Other Observations | 9 |
| Plant Operating Pond | 11 |
| Crest..... | 11 |
| Upstream Embankment..... | 12 |
| Downstream Embankment..... | 14 |
| Storm Drain Pond | 17 |
| Crest..... | 18 |
| Upstream Embankment..... | 19 |
| Downstream Embankment..... | 22 |
| Oil Skimmer:..... | 23 |
| Inactive Solid Waste Disposal Area..... | 24 |

Attachment 1: Inspection Checklists

Attachment 2: Inspection Maps

PAGE (S) REMOVED

NOT IN SCOPE

The last recorded rainfall event occurred over a three day period. The plant recorded 0.55 inches of rain on February 2nd, 0.62 inches on February 3rd and 0.02 inches on February 4th, 2012. On the date of inspection, the ground was moist and there were areas of standing water present.

North and South Bottom Ash Pond:

The North and South Bottom Ash Ponds are adjacent to each other and can be found approximately 1,000 feet northwest of the plant. The clay-lined surface impoundments are used to hold metal-cleaning wastes, waste water treatment wastes, and bottom ash contained in transporter sluice water. The rectangular impoundments measure approximately 1,400 feet by 264 feet at the crest. Each pond surface area is 9.6 acres and is surrounded by an earth embankment that serves as a containment dike. The slope of the perimeter dike is approximately 2.5 Horizontal: 1 Vertical. The depth of the impoundments from the top of the dike to the top of the clay liner is approximately 22 feet. Each pond will hold about 44 million gallons when the fluid level is at the top of the dike or about 38 million gallons (or 114 acre-feet) with 3 feet of freeboard.

Each impoundment is constructed with a compacted clay liner 3 feet thick underlying the bottom and interior dike slopes. The clay liner does not extend beyond the centerline of the crest.

The top of the dike surrounding the ponds is approximately 14 to 21 feet above surrounding grade. Surface runoff does not enter the impoundments.

On the day of the inspection, the water elevation in the North Bottom Ash Pond was approximately 346.9 feet. The South Bottom Ash Pond had an elevation of 346.6 feet.

Crest

In general, the crest of the impoundment was in good condition (Figures 2 and 3).



Figure 2: Crest of North Impoundment



Figure 3: Crest of North Impoundment

MODERATE ITEM: The crest of the impoundment had areas with rutting from vehicular traffic (Figures 4 and 5) in localized areas around the entire pond.

Recommendation 1: Repair damaged areas and grade to drain.

Recommendation 2: Discourage vehicular traffic from driving on impoundment crests after storm events.



Figure 4: Crest Rutting North Pond



Figure 5: Crest Rutting South Pond

Upstream Embankment

MODERATE ITEM: Wave erosion was observed on the North Pond (Figure 6). Erosion matting was installed to mitigate the erosion along the upstream embankments of both ponds. The matting installed in the North Pond did not appear to be functioning as well as the matting installed on the South Pond (Figure 7). The North Pond was emptied in 2011 and repairs were made to the liner and protective cover. The South Pond was emptied and repaired in 2009.

Recommendation 1: Repair upstream embankment on North Pond using the same erosion matting installed on the South Pond.

Recommendation 2: Continue to monitor erosion to protective cover over liner and repair as needed with riprap.

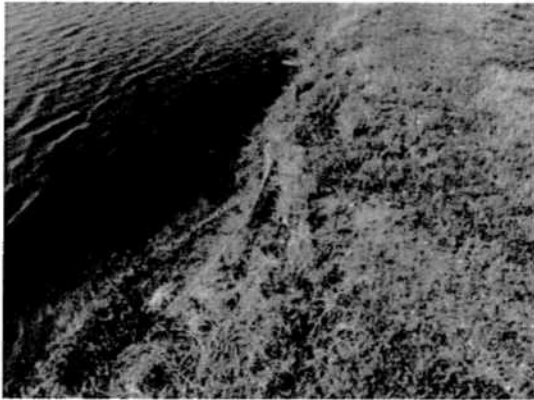

Figure 6: North Pond Embankment (Note geotextile separation and erosion).



Figure 7: South Pond Upstream Embankment (Note geotextile well placed and functioning as intended)

MODERATE ITEM: The South Bottom Ash Pond had isolated areas of cattails and other vegetation growing on the upstream embankment (Figures: 8 and 9).

Recommendation 1: Remove cattails and undesirable vegetation (bushes) from upstream embankment. Repair surface areas disturbed by removal of large vegetation (bushes).



Figure 8: Cattails South Pond



Figure 9: Bush Growing South Pond Embankment

Downstream Embankment

In general, the downstream side of the impoundment embankment was in good condition (Figures 10 and 11).

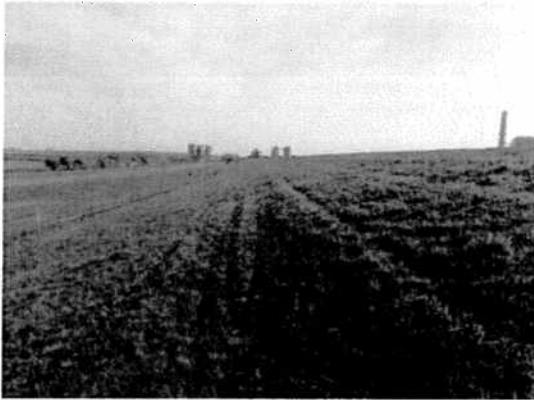

Figure 10: Downstream Embankment North Pond



Figure 11: Downstream Embankment South Pond

MODERATE ITEM: Animal burrows were found in the downstream embankment of both ponds (Figures 12 and 13).

Recommendation 1: Backfill burrows with compacted cohesive soil and reestablish vegetation.

Recommendation 2: Continue to monitor for burrow reestablishment or erosion to restored areas.

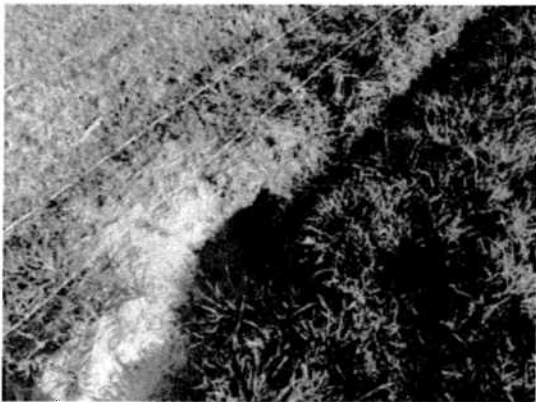

Figure 12: North Pond Animal Burrow



Figure 13: South Pond Animal Burrows

MODERATE ITEM: Bare areas were found at a couple of areas along the downstream face of the embankment around both ponds (Figures: 14 and 15).

Recommendation 1: Reseed and reestablish vegetation in these bare areas.

Recommendation 2: Continue to monitor for additional erosion after re-vegetation.



Figure 14: Bare Area North Pond



Figure 15: Bare Area South Pond

MODERATE ITEM: Water is ponding at the toe of both ponds in isolated areas (Figures 16 and 17). It is assumed the water was from recent storm activities, but this could also represent seepage from the impoundment.

Recommendation 1: Continue to monitor these low areas, especially during dry (i.e., rain free) periods to determine if this is storm water or water migrating from the ponds.

Recommendation 2: Provide compacted cohesive fill soil and grade to eliminate the ponding areas.



Figure 16: North Pond Standing Water at Toe



Figure 17: South Pond Standing Water at Toe

Other Observations

MODERATE ITEM: The North Bottom Ash Pond pipe rack has wave erosion at the foundation (Figures 18 and 19).

Recommendation 1: Backfill bare erosion gullies with compacted cohesive soil and reestablish vegetation.

Recommendation 2: Place riprap in areas of concentrated flow.

Recommendation 3: Continue to monitor areas after repairs for additional erosion.

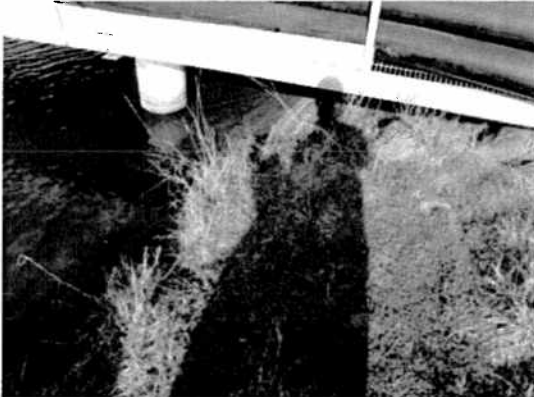

Figure 18: North Pond Pipe Rack Erosion

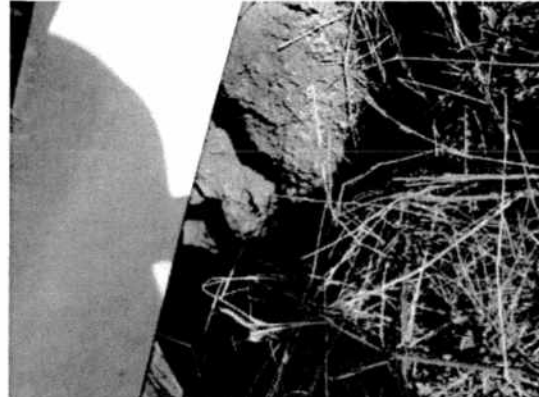

Figure 19: North Pond Pipe Rack Erosion

MODERATE ITEM: The pipe rack at the South Bottom Ash Pond has erosion gullies undercutting the slab foundation (Figures 20 and 21).

Recommendation 1: Backfill bare erosion gullies with compacted cohesive soil, grade and reestablish vegetation. Place and pack grave or grout in voids beneath concrete slab.

Recommendation 2: Place riprap or stone in areas of concentrated flow.

Recommendation 3: Continue to monitor areas after repairs for additional erosion.

PAGE (S) REMOVED

NOT IN SCOPE

ATTACHMENT 1
Inspection Checklists

IMPOUNDMENT INSPECTION CHECKLIST

| Impoundment: North and South Bottom Ash Ponds | | | Inspection Date: 2/8/12 | Weather: Sunny | | | | | | | | | | |
|--|------|------------------------|------------------------------|-----------------------------|----------|--------------|---------|--|--------|----------|----------|-------|---------|--|
| Inspected By: Mark Kelly, Will Steen and Dave Vogt | | | Last Inspection Date: 1/7/11 | | | | | | | | | | | |
| Element | Item | Component | Current Observations | Change From Last Inspection | | | | | Action | | | | | |
| | | | | Similar | Improved | Deteriorated | Unknown | | OK | Critical | Moderate | Minor | Monitor | |
| Crest | 1 | Surface Cracking | | X | | | | | X | | | | | |
| | 2 | Animal Burrows | | X | | | | | X | | | | | |
| | 3 | Crest Sinks | | X | | | | | X | | | | | |
| | 4 | Horizontal Alignment | | X | | | | | X | | | | | |
| | 5 | Ruts/Puddles | | X | | | | | | | X | | | |
| | 6 | Vegetation | | X | | | | | X | | | | | |
| | 7 | Trees | | X | | | | | X | | | | | |
| | 8 | Piezometer Readings | | | | | X | | | | | | | |
| | 9 | Piezometer Condition | | | | | X | | | | | | | |
| Upstream Embankment and Cap Area | 10 | Cap Erosion | | X | | | | | X | | | | | |
| | 11 | Cap Vegetation/Trees | | X | | | | | X | | | | | |
| | 12 | Berm Slide, Slough | | X | | | | | X | | | | | |
| | 13 | Slope Protection | | X | | | | | X | | | | | |
| | 14 | Berm Sinks | | X | | | | | X | | | | | |
| | 15 | Animal Burrows | | X | | | | | X | | | | | |
| | 16 | Abutment Contact | | X | | | | | X | | | | | |
| | 17 | Erosion | | X | | | | | | | X | | | |
| | 18 | Vegetation | | X | | | | | | | X | | | |
| | 19 | Trees | | X | | | | | X | | | | | |
| | 20 | Drains | | X | | | | | X | | | | | |
| Downstream Embankment | 21 | Berm Bulges | | X | | | | | X | | | | | |
| | 22 | Wet Areas/Seepage | | X | | | | | | | X | | | |
| | 23 | Estimated Seepage Rate | | X | | | | | X | | | | | |
| | 24 | Seepage Description | | X | | | | | X | | | | | |
| | 25 | Toe Drain Status | | X | | | | | X | | | | | |
| | 26 | Berm Slide/Slough | | X | | | | | X | | | | | |
| | 27 | Abutment Contact | | X | | | | | X | | | | | |
| | 28 | Animal Burrows | | X | | | | | | | X | | | |
| | 29 | Erosion | | X | | | | | | | X | | | |
| | 30 | Unusual Movement | | X | | | | | X | | | | | |
| | 31 | Vegetation | | X | | | | | X | | | | | |
| | 32 | Trees | | X | | | | | X | | | | | |
| | 33 | Piezometer Reading | | | | | X | | | | | | | |
| | 34 | Piezometer Condition | | | | | X | | | | | | | |

Comments and Photo Information:

PAGE (S) REMOVED

NOT IN SCOPE

ATTACHMENT 2

Inspection Maps



HDR
 HYDROLOGICAL DESIGN, INC.
 2414 West 15th Street
 Suite 200
 Fort Worth, Texas 76148
 Phone: 817.333.8000
 Fax: 817.333.8001

| ISSUE | DATE | DESCRIPTION |
|-------|------|-------------|
| | | |
| | | |

PROJECT MANAGER: DWIGHT
 CIVIL ENGINEER: DWIGHT
 CHECKED BY: _____
 DESIGNED BY: _____
 DRAWN BY: DWIGHT
 DATE: 04/20/12
 PROJECT NUMBER: 179568

PRELIMINARY
 FOR INFORMATION ONLY. NOT FOR PERMITTING, BIDDING, OR CONSTRUCTION.
 Property is owned by
 DWIGHT WOODS RE TRANSFER
 #10520

BIG BROWN STEAM ELECTRIC STATION
 FREESTONE COUNTY, TEXAS

IMPOUNDMENT INSPECTIONS
 SHEET 1 OF 4
 FILE NAME: BBL_S01.dwg
 SCALE: _____
 SHEET: **BB1**



| POINT NO. | NOTATION | METHOD | DESCRIPTION |
|-----------|----------|----------|-------------|
| 1 | + | TRAVELER | TRAVELER |
| 2 | + | TRAVELER | TRAVELER |
| 3 | + | TRAVELER | TRAVELER |
| 4 | + | TRAVELER | TRAVELER |
| 5 | + | TRAVELER | TRAVELER |
| 6 | + | TRAVELER | TRAVELER |
| 7 | + | TRAVELER | TRAVELER |
| 8 | + | TRAVELER | TRAVELER |
| 9 | + | TRAVELER | TRAVELER |
| 10 | + | TRAVELER | TRAVELER |
| 11 | + | TRAVELER | TRAVELER |
| 12 | + | TRAVELER | TRAVELER |
| 13 | + | TRAVELER | TRAVELER |
| 14 | + | TRAVELER | TRAVELER |
| 15 | + | TRAVELER | TRAVELER |
| 16 | + | TRAVELER | TRAVELER |

LEGEND
 + MARKED POINTS WITH COORDINATES
 X BUSH MARKED POINTS WITHOUT COORDINATES

PAGE (S) REMOVED

NOT IN SCOPE

APPENDIX A

Document 5

NPDES Permit No. TN 85003-0-02



TEXAS COMMISSION ON ENVIRONMENTAL QUALITY
P. O. Box 13087
Austin, Texas 78711-3087

TPDES PERMIT NO. WQ0001309000
[For TCEQ office use only -
EPA I.D. No. TX0030180]

This is a renewal of TCEQ Permit No.
WQ0001309000, issued on December
28, 2004.

PERMIT TO DISCHARGE WASTES
under provisions of
Section 402 of the Clean Water Act
and Chapter 26 of the Texas Water Code

TXU Big Brown Company LP (Owner) and TXU Generation Company LP (Operator)

whose mailing address is

c/o Water Programs Coordinator
Environmental Services
Energy Plaza
1601 Bryan Street
Dallas, Texas 75201-3411

is authorized to treat and discharge wastes from the Big Brown Steam Electric Station, a steam power generating facility (SIC 4911)

located on the north bank of Fairfield Lake on Farm-to-Market Road 2570, approximately 11 miles northeast of the City of Fairfield, Freestone County, Texas

to Fairfield Lake; thence to Big Brown Creek; thence to Tehuacana Creek; thence to the Trinity River Above Lake Livingston in Segment No. 0804 of the Trinity River Basin

only according to effluent limitations, monitoring requirements and other conditions set forth in this permit, as well as the rules of the Texas Commission on Environmental Quality (TCEQ), the laws of the State of Texas, and other orders of the TCEQ. The issuance of this permit does not grant to the permittee the right to use private or public property for conveyance of wastewater along the discharge route described in this permit. This includes, but is not limited to, property belonging to any individual, partnership, corporation or other entity. Neither does this permit authorize any invasion of personal rights nor any violation of federal, state, or local laws or regulations. It is the responsibility of the permittee to acquire property rights as may be necessary to use the discharge route.

This permit shall expire at midnight on February 1, 2012.

ISSUED DATE: **APR 18 2007**

A handwritten signature in black ink, appearing to be "D. M. ...", written over a horizontal line.

For the Commission

APPENDIX A

Document 6

FLOW CHART, Big Brown Steam Electric Station

FLOW CHART

Luminant Generation Company, LLC
 Big Brown Steam Electric Station
 Bottom Ash Ponds

FOR INFORMATION ONLY

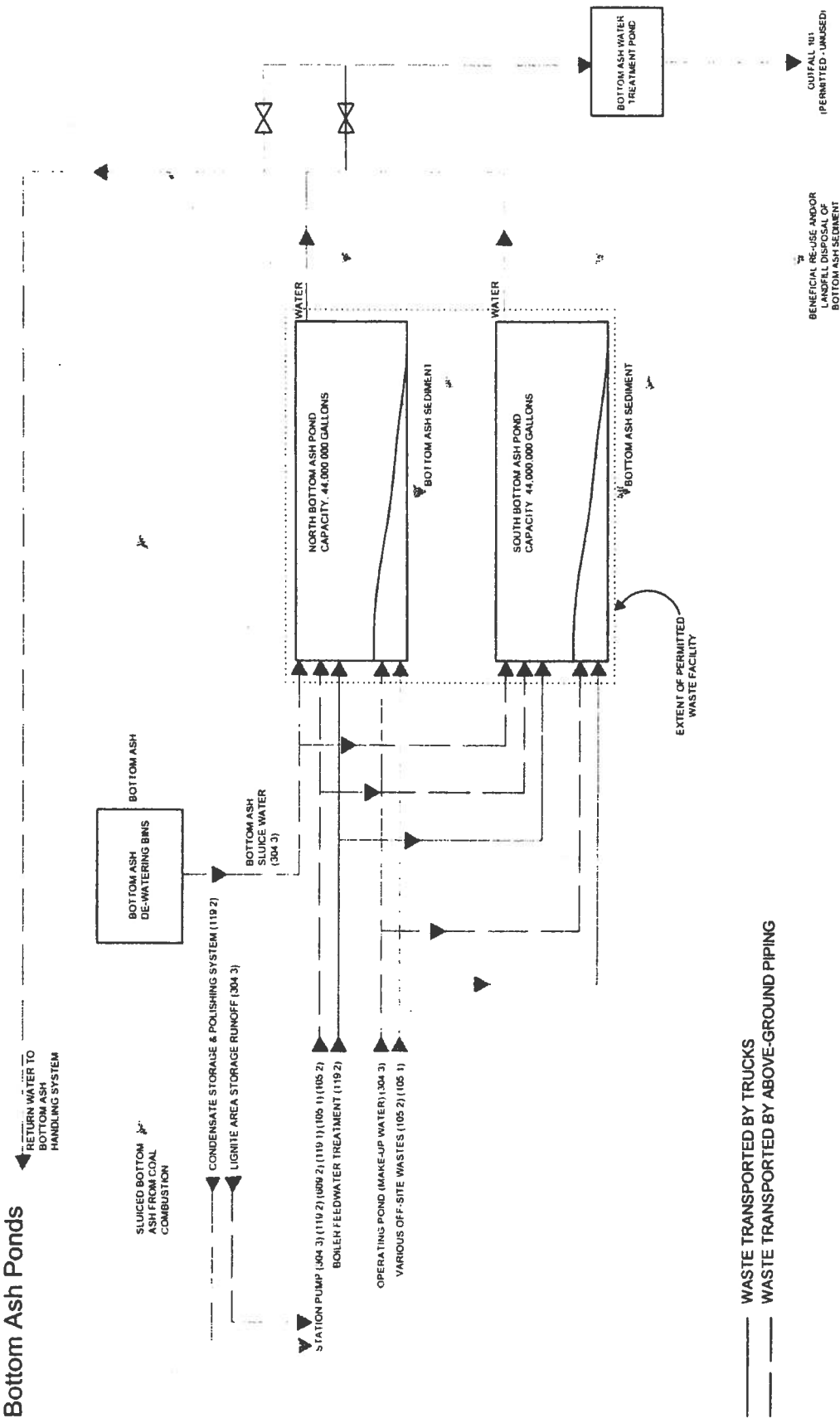

WASTE TRANSPORTED BY TRUCKS
 WASTE TRANSPORTED BY ABOVE-GROUND PIPING

APPENDIX B

Document 7

Dam Inspection Check List Lime and Ash Pond



| | | | |
|--------------------------|---|---|--|
| Site Name: | Big Brown Steam Electric Station | Date: | September 26, 2012 |
| Unit Name: | Bottom Ash Pond | Operator's Name: | Luminant |
| Unit I.D.: | | Hazard Potential Classification: | High <input type="checkbox"/> Significant <input type="checkbox"/> Low <input checked="" type="checkbox"/> |
| Inspector's Name: | | Michael McLaren, P.E. and Joe Klein, P.E. | |

Check the appropriate box below. Provide comments when appropriate. If not applicable or not available, record "N/A". Any unusual conditions or construction practices that should be noted in the comments section. For large diked embankments, separate checklists may be used for different embankment areas. If separate forms are used, identify approximate area that the form applies to in comments.

| | Yes | No | | Yes | No |
|--|--------|-----|---|-----|-----|
| 1. Frequency of Company's Dam Inspections? | X | | 18. Sloughing or bulging on slopes? | | X |
| 2. Pool elevation (operator records)? | 347 ft | | 19. Major erosion or slope deterioration? | | X |
| 3. Decant inlet elevation (operator records)? | | N/A | 20. Decant Pipes: | | |
| 4. Open channel spillway elevation (operator records)? | | N/A | Is water entering inlet, but not exiting outlet? | | N/A |
| 5. Lowest dam crest elevation (operator records)? | 350 ft | | Is water exiting outlet, but not entering inlet? | | N/A |
| 6. If instrumentation is present, are readings recorded (operator records)? | X | | Is water exiting outlet flowing clear? | | N/A |
| 7. Is the embankment currently under construction? | | X | 21. Seepage (specify location, if seepage carries fines, and approximate seepage rate below): | | |
| 8. Foundation preparation (remove vegetation, stumps, topsoil in area where embankment fill will be placed)? | | INA | From underdrain? | | X |
| 9. Trees growing on embankment? (If so, indicate largest diameter below) | | X | At isolated points on embankment slopes? | | X |
| 10. Cracks or scarps on crest? | | X | At natural hillside in the embankment area? | | X |
| 11. Is there significant settlement along the crest? | | X | Over widespread areas? | | X |
| 12. Are decant trashracks clear and in place? | | N/A | From downstream foundation area? | | X |
| 13. Depressions or sinkholes in tailings surface or whirlpool in the pool area? | | X | "Boils" beneath stream or ponded water? | | X |
| 14. Clogged spillways, groin or diversion ditches? | | N/A | Around the outside of the decant pipe? | | X |
| 15. Are spillway or ditch linings deteriorated? | | N/A | 22. Surface movements in valley bottom or on hillside? | | X |
| 16. Are outlets of decant or underdrains blocked? | | N/A | 23. Water against downstream toe? | | X |
| 17. Cracks or scarps on slopes? | | X | 24. Were Photos taken during the dam inspection? | X | |

Major adverse changes in these items could cause instability and should be reported for further evaluation. Adverse conditions noted in these items should normally be described (extent, location, volume, etc.) in the space below and on the back of this sheet.

| Issue # | Comments |
|--------------------------|--|
| 1 | Formal inspections conducted annually. Daily inspections conducted by plant staff and documented using checklist reports. |
| 3, 4, 12, 14, 15, 16, 20 | Bottom Ash Pond consists of two cells. Each cell has a suction pipe inlet on the opposite end from the sluice outlet. The suction pipe flows to a valve box used to recycle water to the plant. In abnormal conditions, the pipe flow can be rerouted to the process water pond for discharge to Fairfield Lake. |
| 6 | Piezometers at toe of embankment. Piezometers read semi-annually. |
| 8 | INA: Information Not Available |

US EPA ARCHIVE DOCUMENT



Coal Combustion Waste (CCW) Impoundment Inspection

Impoundment NPDES Permit WQ0001309000 **INSPECTOR** Mike McLaren
Joe Klein

Date September 26, 2012
Impoundment Name Bottom Ash Pond
Big Brown Steam Electric Station

Impoundment Company TXU Big Brown Company, LP
EPA Region 6

State Agency Texas Commission on Environmental Quality
(Field Office) Address P.O. Box 13087
Austin, TX 78711

Name of Impoundment Big Brown Steam Electric Station
Bottom Ash Pond

(Report each impoundment on a separate form under the same Impoundment NPDES Permit number)

New **Update**

| | | |
|---|-------------------------------------|-------------------------------------|
| | Yes | No |
| Is impoundment currently under construction? | <input type="checkbox"/> | <input checked="" type="checkbox"/> |
| Is water or ccw currently being pumped into the impoundment? | <input checked="" type="checkbox"/> | <input type="checkbox"/> |

IMPOUNDMENT FUNCTION: Receive and store sluiced bottom ash

Nearest Downstream Town Name: There are no towns downstream of the plant location between it and the Trinity River. There are no towns along the Trinity River in the general area of the plant site.

Distance from the impoundment: Trinity River is about 4 miles east of Big Brown Steam Electric Station

Location:

| | | | | | | | |
|------------------|----|---------|----|---------|-------|---------|----------|
| Latitude | 31 | Degrees | 49 | Minutes | 18.47 | Seconds | N |
| Longitude | 96 | Degrees | 03 | Minutes | 39.44 | Seconds | W |

State Texas **County** Freestone

| | | |
|---|-------------------------------------|--------------------------|
| | Yes | No |
| Does a state agency regulate this impoundment? | <input checked="" type="checkbox"/> | <input type="checkbox"/> |

If So Which State Agency? Texas Commission on Environmental Quality

US EPA ARCHIVE DOCUMENT



HAZARD POTENTIAL *(In the event the impoundment should fail, the following would occur):*

- LESS THAN LOW HAZARD POTENTIAL:** Failure or misoperation of the dam results in no probable loss of human life or economic or environmental losses.
- LOW HAZARD POTENTIAL:** Dams assigned the low hazard potential classification are those where failure or misoperation results in no probable loss of human life and low economic and/or environmental losses. Losses are principally limited to the owner’s property.
- SIGNIFICANT HAZARD POTENTIAL:** Dams assigned the significant hazard potential classification are those dams where failure or misoperation results in no probable loss of human life but can cause economic loss, environmental damage, disruption of lifeline facilities, or can impact other concerns. Significant hazard potential classification dams are often located in predominantly rural or agricultural areas but could be located in areas with population and significant infrastructure.
- HIGH HAZARD POTENTIAL:** Dams assigned the high hazard potential classification are those where failure or misoperation will probably cause loss of human life.

DESCRIBE REASONING FOR HAZARD RATING CHOSEN:

Based on the size and location of the Big Brown Steam Electric Station Bottom Ash Pond, there is no probable loss of life in the event of failure or misoperation. Economic and environmental losses are expected to be low and limited to the owner’s property. The plant owner owns Fairfield Lake and most of the surrounding property. There is a State Park located on the upper end of Fairfield Lake. The park property is owned by Luminant and leased to the State for a nominal annual amount to provide public recreational access to the lake.

US EPA ARCHIVE DOCUMENT



CONFIGURATION:

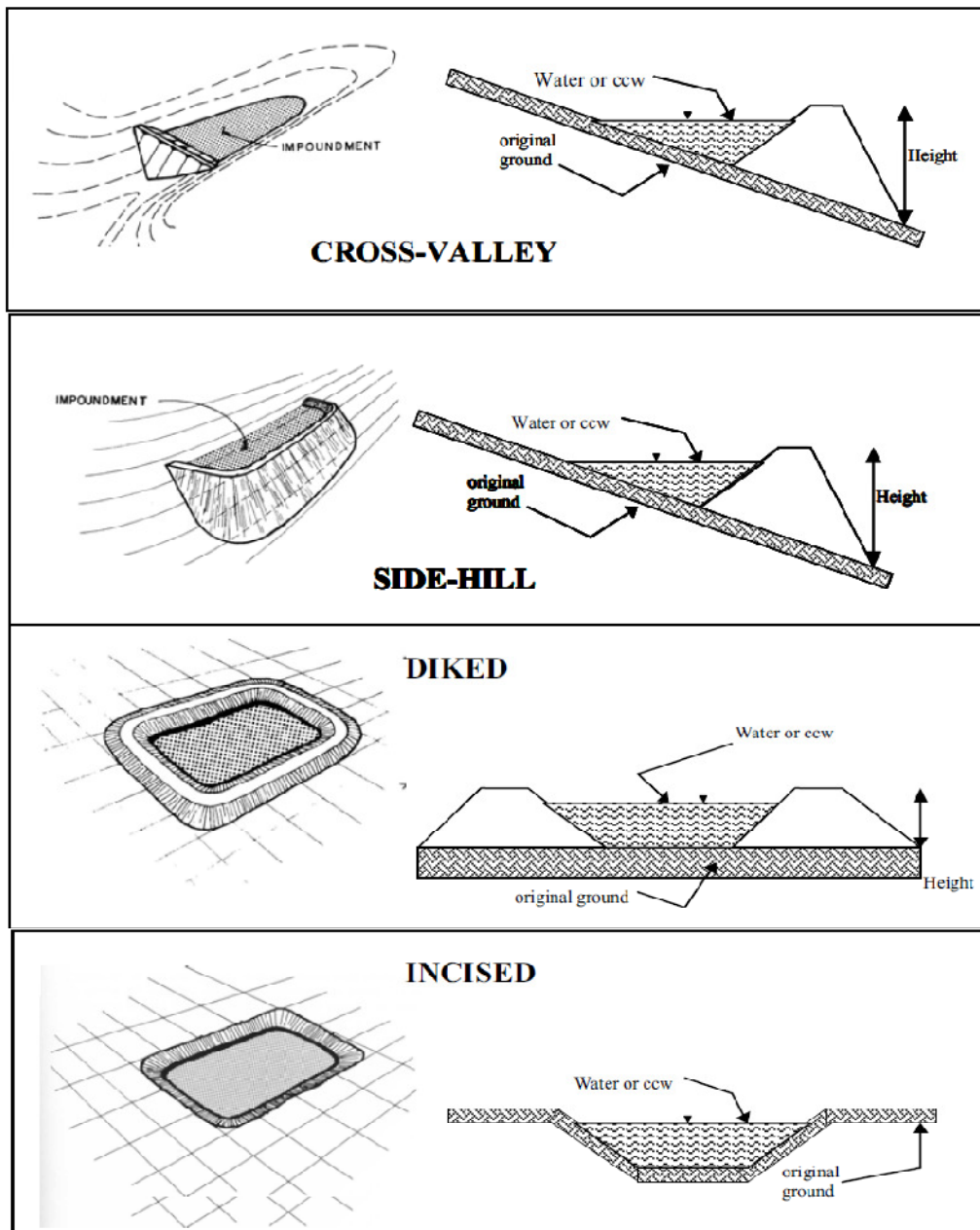

- Cross-Valley
- Side-Hill
- Diked
- Incised (form completion optional)
- Combination Incised/Diked

| | | | |
|-------------------------------|------|----------------------------|-------------------------|
| Embankment Height (ft) | 25 | Embankment Material | Soil Fill |
| Pool Area (ac) | 19.3 | Liner | Compacted Clay |
| Current Freeboard (ft) | 3 | Liner Permeability | 10 ⁻⁷ cm/sec |

US EPA ARCHIVE DOCUMENT



TYPE OF OUTLET (Mark all that apply)

Open Channel Spillway

Trapezoidal

Triangular

Rectangular

Irregular

depth (ft)

average bottom width (ft)

top width (ft)

TRAPEZOIDAL

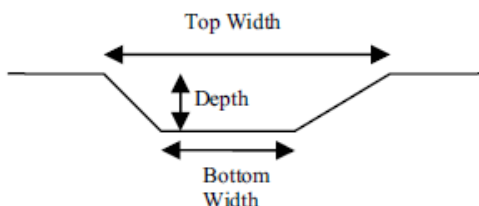

TRIANGULAR

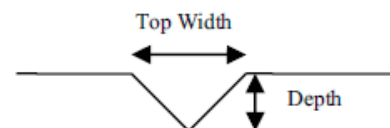

RECTANGULAR

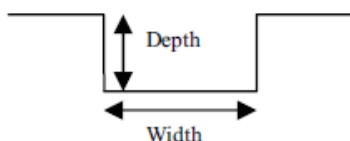

IRREGULAR

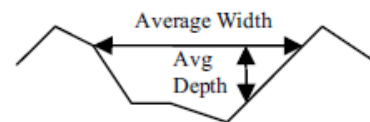

Outlet

18" inside diameter
(SDR 17 – smooth lined – 19.5" OD)

Material

corrugated metal

welded steel

concrete

plastic (hdpe, pvc, etc.)

other (specify):

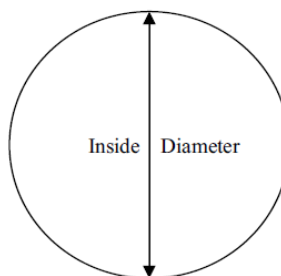

Is water flowing through the outlet?

Yes

No

No Outlet

Other Type of Outlet
(specify):

Water from each of two cells is pumped from the bottom of the pond and recycled to the plant. In abnormal conditions, valves can direct pump discharge to plant discharge canal.

In emergency event, temporary pumps deployed to pump

US EPA ARCHIVE DOCUMENT



water into the plant discharge canal.

The Impoundment was Designed By **Luminant**

| | | |
|---|--------------------------|-------------------------------------|
| | Yes | No |
| Has there ever been a failure at this site? | <input type="checkbox"/> | <input checked="" type="checkbox"/> |

If So When?

If So Please Describe :

| | | |
|--|--------------------------|-------------------------------------|
| | Yes | No |
| Has there ever been significant seepages at this site? | <input type="checkbox"/> | <input checked="" type="checkbox"/> |

If So When?

If So Please Describe :

| | | |
|---|--------------------------|-------------------------------------|
| | Yes | No |
| Has there ever been any measures undertaken to monitor/lower Phreatic water table levels based on past seepages or breaches at this site? | <input type="checkbox"/> | <input checked="" type="checkbox"/> |

If so, which method (e.g., piezometers, gw pumping,...)?

If So Please Describe :

US EPA ARCHIVE DOCUMENT

**ADDITIONAL INSPECTION QUESTIONS**

Concerning the embankment foundation, was the embankment construction built over wet ash, slag, or other unsuitable materials? If there is no information just note that.

No formal documentation was available. However, it was reported that the Bottom Ash Pond was included in the original plant development. In the late 1980s and early 1990s both cells of the pond were upgraded. The upgrade included removal of stored ash, construction of a compacted clay liner and improvements at the suction line pipe inlets.

Observations during the site visit indicate the embankments were constructed on natural ground.

Did the dam assessor meet with, or have documentation from, the design Engineer-of-Record concerning the foundation preparation?

No documentation of original foundation preparation was provided.

From the site visit or from photographic documentation, was there evidence of prior releases, failures, or patchwork on the dikes?

Neither observations during the site visit, nor photographs in prior inspection reports provided to Dewberry indicate prior releases, failures or patchwork on the dikes.

APPENDIX C

Document 8

Ash Pond Slope Stability Investigation Report, Golder Associates Inc., November 2012 (Revised December 2012)



REPORT

ASH POND SLOPE STABILITY INVESTIGATION REPORT

**Big Brown Power Plant
Freestone County, Texas**

Submitted To: Luminant – Systems Engineering
Energy Plaza, Floor 27
1601 Bryan Street
Dallas, Texas 75201

Submitted By: Golder Associates Inc.
500 Century Plaza Drive, Suite 190
Houston, TX 77073 USA
Texas Registration Number: F-2578



P. Chris Marshall

November 2012 (Revised December 2012)

123-94128.001

**A world of
capabilities
delivered locally**





Table of Contents

| | | |
|-----|---|---|
| 1.0 | INTRODUCTION..... | 1 |
| 1.1 | Project Description | 1 |
| 1.2 | Scope of the Investigation..... | 1 |
| 1.3 | Coordinate System and Unit System | 1 |
| 2.0 | SUBSURFACE INVESTIGATION..... | 2 |
| 2.1 | Soil Boring Procedures | 2 |
| 2.2 | Laboratory Testing | 3 |
| 2.3 | Subsurface Conditions | 3 |
| 3.0 | STABILITY ANALYSES | 5 |
| 3.1 | Soil Properties | 5 |
| 3.2 | Slope Stability Results | 6 |
| 4.0 | IMPORTANT INFORMATION..... | 7 |
| 5.0 | CLOSING | 8 |

List of Tables

| | | |
|---------|---|---|
| Table 1 | Boring Coordinates | 2 |
| Table 2 | Soil Material Properties | 6 |
| Table 3 | Slope Stability Factors of Safety | 6 |

List of Figures

| | |
|----------|----------------------|
| Figure 1 | Boring Location Plan |
| Figure 2 | Analysis Locations |

List of Appendices

| | |
|------------|--|
| Appendix A | Boring Logs |
| Appendix B | Laboratory Test Summary Sheets |
| Appendix C | Laboratory Test Results |
| Appendix D | Slope Stability Calculations |
| Appendix E | Important Information About This Geotechnical Report |

US EPA ARCHIVE DOCUMENT





1.0 INTRODUCTION

This revised report supersedes original report submitted to Luminant on November 21, 2012.

1.1 Project Description

Luminant Power (Luminant) operates the Big Brown Power Plant, a lignite-fueled power plant near Fairfield, Freestone County, Texas. As part of regulatory compliance, the existing ash ponds are being characterized for slope stability. The ash ponds are located northwest of the power plant. The ash ponds consist of two adjacent ponds that share a dike that separates the two ponds. Each ash pond encompasses an area of approximately 8 acres.

Golder Associates Inc. (Golder) has been contracted by Luminant to perform a geotechnical site investigation at the facility and analyze the ash pond slope stability. This report presents the findings of the field investigation, boring logs, laboratory test results, a description of the subsurface soil conditions, and results of the slope stability analyses.

1.2 Scope of the Investigation

The scope of this investigation included:

- Drilling and sampling of six (6) geotechnical soil borings,
- Laboratory testing of representative soil samples,
- Characterization of subsurface conditions, and
- Slope stability analyses.

The subsurface investigation was performed on October 15, 16, and 17, 2012.

1.3 Coordinate System and Unit System

The soils boring locations and elevations were estimated by Golder using existing topographic maps and aerial imagery. We have reported coordinates with reference to latitude and longitude with WGS84 datum. All elevations are referenced to mean sea level (msl).

This report is presented using U.S. customary (or English) units.



2.0 SUBSURFACE INVESTIGATION

Golder performed a subsurface investigation that included six (6) soil borings. Two (2) borings were drilled to a depth of 30 feet below ground surface (bgs) and four (4) borings were drilled to a depth of 50 feet bgs. Table 1 provides the boring coordinates and elevations. The soils boring locations and elevations were estimated by Golder using existing topographic maps and aerial imagery. Boring locations are shown on Figure 1.

TABLE 1. BORING COORDINATES

| Boring Number | Latitude | Longitude | Elevation (ft-msl) | Boring Depth (ft) |
|---------------|------------|------------|--------------------|-------------------|
| BH-1 | 31°49'21"N | 96° 3'41"W | 350 | 50 |
| BH-2 | 31°49'18"N | 96° 3'48"W | 350 | 50 |
| BH-3 | 31°49'14"N | 96° 3'54"W | 350 | 30 |
| BH-4 | 31°49'10"N | 96° 3'51"W | 350 | 30 |
| BH-5 | 31°49'13"N | 96° 3'44"W | 350 | 50 |
| BH-6 | 31°49'17"N | 96° 3'37"W | 350 | 50 |

2.1 Soil Boring Procedures

The borings were drilled by Van and Sons Drilling Service, Inc. using an all terrain truck-mounted drilling rig and rotary drilling methods with solid stem augers. Soil samples were collected at 2.5-foot intervals within the top 10 feet of the boring and at 5-foot intervals below 10 feet. The boring logs from the site investigation are included as Appendix A.

Disturbed soil samples were obtained in sand using an ASTM standard split spoon sampler, i.e., 2-inch outer diameter and 1-3/8- inch inner diameter. Standard Penetration Tests (SPT) were conducted during sampling. Sampling and testing were carried out in general agreement with the guidelines in ASTM D1586.

SPTs involve counting the number of blows of a 140 lb hammer dropping 30 inches needed for the sampler to penetrate three successive 6-inch increments into the soil. The reported N value is the number of blows required to penetrate the second and third 6-inch intervals, with units of blows/12 inches. In some hard clays and very dense sands, 50 blows are insufficient to advance the sampler 6 inches and penetration "refusal" was encountered. In this case the N value is not obtained and the incomplete penetration is recorded. This is registered in the boring logs as, for example, 50/5 in., i.e. 50 blows with only 5 inches of penetration.



Select samples were obtained in clayey soils using steel Shelby tubes. Shelby tubes were 30-inch long and 3-inch outer diameter (OD). The inside diameter was 2.87 inch giving an area ratio of 9% ($C_a = 100 \times (OD^2 - ID^2)/ID^2$). These Shelby tubes have a cutting edge diameter (D_e) of 2.85 in., thus an inside clearance ratio ($C_i = 100 \times (ID - D_e)/D_e$) equal to 0.7%. The recovery ratio (length recovered/length pushed) is typically variable and dependent on the soil stiffness, with higher recovery values generally obtained in softer clays. The recovery ratio is reported in the individual boring logs.

All borings were sampled by a Golder field engineer and the soils were described using a modified version of the Unified Soil Classification System (ASTM D 2487). The soil description included a density or consistency qualifier, color, structural characteristics when evident, composition with major component in capital letters, and minor characteristics.

After visual classification, recovered samples from SPTs were placed in plastic bags to preserve the natural moisture content. After retrieval and visual soil identification of each Shelby tube sample, a pocket penetrometer test was performed at the bottom end of the sample. Shelby tubes pushed in stiff to hard clayey soils were extruded in the field and the recovered samples were placed in plastic storage tubes and plastic bags to preserve the moisture content. All samples were labeled and transported back to the Golder's Houston office for laboratory soils testing.

Boring logs were prepared from the field logs using the software package gINT v. 8.1.021. The boring logs are provided in Appendix A.

Following the completion of the ash pond soil borings, the boreholes were backfilled with bentonite grout and finished with cement to the surface.

2.2 Laboratory Testing

Laboratory testing was performed on selected samples, in accordance with commonly accepted methods and practices. Undisturbed and disturbed soil samples were tested to determine water content, Atterberg limits, grain size distribution, and shear strength. Water content determination was performed in accordance with ASTM D2216; Atterberg limits were determined in accordance with ASTM D4318; and grain size distribution was performed in accordance with ASTM D422. Shear strength testing consisted of unconsolidated-undrained (UU) and consolidated-undrained (CU) triaxial compression tests in general accordance with ASTM D2850 and D4767, respectively. Laboratory data summary sheets are presented in Appendix B. Laboratory test result sheets are presented in Appendix C.

2.3 Subsurface Conditions

The soils encountered in the borings generally consist of very stiff to hard sandy clays and compact to very dense clayey sands. The subsurface stratigraphy generally consists of clayey or silty sand with



interspersed layers of sandy clay and lean clay. The sandy clay and lean clay layers range in thickness from approximately 5 to 17 feet. A thin (less than 5 feet thick) layer of loose to compact clayey sand was encountered in BH-1, BH-2 and BH-5 at a depth of approximately 44 feet bgs. All of the borings except BH-3 and BH-6 were terminated in a stratum of compact to very dense silty sand. BH-3 and BH-6 were terminated in layers of dense to very dense sand.

Groundwater was encountered in 2 of the 6 borings. Groundwater elevations encountered during drilling ranged from 320 to 332 ft-msl. Our analyses were conducted assuming groundwater elevation at each cross section based on the boring closest to that cross section.



3.0 STABILITY ANALYSES

Slope stability analyses were performed using the commercial slope stability software program, SLIDE Version 6.0. The site topography and geometry used in the analyses were determined from site survey and design drawings provided by Luminant.

The typical containment dike section has an interior (wet side) slope of 2.5 horizontal to 1 vertical (2.5H:1V) and a minimum exterior (dry side) slope of 2H:1V. The crest elevation of the containment dike is at approximately 350 ft-msl. The ponds are lined with 3 feet of compacted clay. The top of liner elevation on the pond floors is approximately 328 ft-msl. The most critical slope geometry was identified along the west sideslope, consisting of an approximately 24-foot high, 1.7H:1V slope.

Stability analyses were performed for four (4) separate slope sections to assess the various soil conditions and slope geometries around the ponds; analysis locations are shown on Figure 2. Stability analyses considered “empty pond” and “full pond” conditions.

A rapid drawdown scenario was analyzed for one full pond condition at each section. The analysis was completed on the drained or undrained section with the lower factor of safety in the full condition. The analysis was completed using the B-bar method to simulate the effects of rapid drawdown in a low permeability material such as the sandy clays and clayey sands encountered at Big Brown. The initial water level was modeled as the full condition and the final water level was modeled at the pond floor, representing a final condition after drawdown where the pond is empty.

The most critical slope geometry was identified along the east sideslope. The effect of pseudo-static earthquake loading was also analyzed at this location. The plant is not located in a seismic zone (Reference: Figure 6 of EM 1110-2-1902, “Stability of Earth and Rock-Fill Dams”, U.S. Army Corps of Engineers, 1970), so a nominal seismic coefficient of 0.01g was therefore used in the earthquake loading analysis.

The soils encountered in the borings are not susceptible to liquefaction.

3.1 Soil Properties

For each slope section, a conservative, generalized subsurface stratigraphy was developed based on soil boring information and laboratory soil testing results from the borings conducted as part of this investigation. The soil properties assumed for the slope sections are provided in Table 2.

**TABLE 2. SOIL MATERIAL PROPERTIES**

| Soil Material | Description | Moist Unit Weight (lb/ft ³) | Saturated Unit Weight (lb/ft ³) | Undrained Soil Properties | | Drained Soil Properties | |
|---------------|------------------------|---|---|---|----------------------------|--------------------------------------|-----------------------------|
| | | | | Undrained Shear Strength, s_u (lb/ft ²) | Friction Angle, ϕ (°) | Cohesion, c' (lb/ft ²) | Friction Angle, ϕ' (°) |
| I | Sandy Clay/Clayey Sand | 127 | 132 | 1500 | 0 | 1000 | 14 |
| II | Clean Sand | 127 | 132 | 0 | 29 | 0 | 29 |

3.2 Slope Stability Results

Slope stability analyses were performed for both short-term and long-term conditions using undrained and drained soil properties, respectively. The results of the analyses are provided in Table 3. SLIDE output files are included in Appendix D. A factor of safety of 1.5 is typically considered adequate for permanent slopes. The minimum calculated factor of safety from our analyses is 2.5 (Case 2) for normal loading conditions. Therefore, our analyses indicate that the slopes are stable. Additionally, slope stability analyses for rapid drawdown and earthquake conditions have factors of safety greater than 1.5 as well.

TABLE 3. SLOPE STABILITY FACTORS OF SAFETY

| Case | Description | Factor of Safety |
|------|---|------------------|
| 1 | East sideslope; empty pond; short-term (undrained) conditions | 2.6 |
| 2 | East sideslope; empty pond; long-term (drained) conditions | 2.5 |
| 3 | East sideslope; full pond; short-term (undrained) conditions | 5.7 |
| 4 | East sideslope; full pond; long-term (drained) conditions | 5.9 |
| 5 | East sideslope; empty pond; long-term (drained) conditions; seismic | 2.4 |
| 6 | East sideslope; rapid drawdown | 2.6 |
| 7 | North sideslope; empty pond; short-term (undrained) conditions | 3.3 |
| 8 | North sideslope; empty pond; long-term (drained) conditions | 3.2 |
| 9 | North sideslope; full pond; short-term (undrained) conditions | 6.3 |
| 10 | North sideslope; full pond; long-term (drained) conditions | 6.6 |
| 11 | North sideslope; rapid drawdown | 3.1 |
| 12 | Northeast sideslope; empty pond; short-term (undrained) conditions | 3.5 |
| 13 | Northeast sideslope; empty pond; long-term (drained) conditions | 3.6 |
| 14 | Northeast sideslope; full pond; short-term (undrained) conditions | 3.5 |
| 15 | Northeast sideslope; full pond; long-term (drained) conditions | 3.6 |
| 16 | Northeast sideslope; rapid drawdown | 3.6 |
| 17 | West sideslope; empty pond; short-term (undrained) conditions | 5.5 |
| 18 | West sideslope; empty pond; long-term (drained) conditions | 4.4 |
| 19 | West sideslope; full pond; short-term (undrained) conditions | 5.4 |
| 20 | West sideslope; full pond; long-term (drained) conditions | 4.4 |
| 21 | West sideslope; rapid drawdown | 4.4 |



4.0 IMPORTANT INFORMATION

Attention is drawn to the document - "Important Information About Your Geotechnical Engineering Report", which is included in Appendix E of this report. This document has been prepared by the ASFE (Professional Firms Practicing in the Geosciences), of which Golder is a member. The statements presented in this document are intended to advise owners of what their realistic expectations of this report should be, and to present recommendations on how to minimize the risks associated with the groundworks for this project. The document is not intended to reduce the level of responsibility accepted by Golder, but rather to ensure that all parties who may rely on this report are aware of the responsibilities each assumes in so doing.



5.0 CLOSING

Golder appreciates the opportunity to assist Luminant with this project. If you have any questions, or require further assistance from Golder, please contact the undersigned at (281) 821-6868.

Very truly yours,

GOLDER ASSOCIATES INC.

P. Chris Marshall, P.E.
Senior Project Engineer

Charles F. Rickert, P.E.
Associate

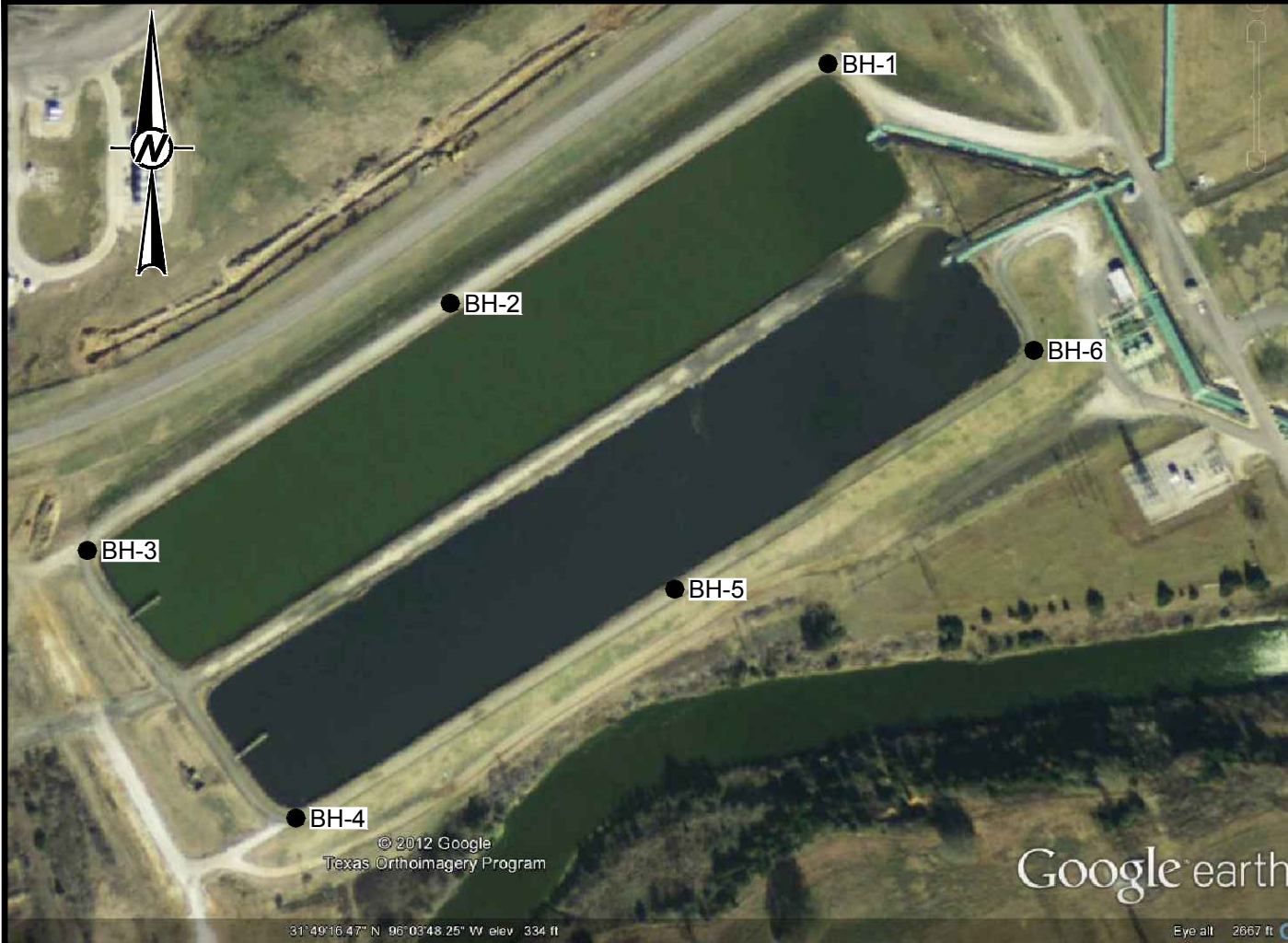

LEGEND

● BH-1 BORING LOCATION

REFERENCES / SPECIFICATIONS

IMAGE SOURCE:
GOOGLE EARTH PRO. 2010

| REV | DATE | REVISION DESCRIPTION | HPR | VJE | HPR | PCM |
|---|------|----------------------|--|----------|-----|--------------|
| | | | DES | CADD | CHK | RWW |
| PROJECT | | | LUMINANT - BIG BROWN ASH POND SLOPE STABILITY INVESTIGATION REPORT FREESTONE COUNTY, TEXAS | | | |
| TITLE | | | BORING LOCATION PLAN | | | |
| PROJECT No. | | | 123-94128 | FILE No. | | 12394128A001 |
| SCALE | | | | | NTS | |
|  | | | FIG-1 | | | |



LEGEND

—— ANALYSIS LOCATION

REFERENCES / SPECIFICATIONS

IMAGE SOURCE:
GOOGLE EARTH PRO. 2010

| REV | DATE | REVISION DESCRIPTION | HPR | VJE | HPR | PCM |
|---|------|--|-----------------------|------|-----|-----|
| | | | DES | CADD | CHK | RWW |
| PROJECT | | LUMINANT - BIG BROWN ASH POND SLOPE STABILITY INVESTIGATION REPORT FREESTONE COUNTY, TEXAS | | | | |
| TITLE | | ANALYSIS LOCATIONS | | | | |
| PROJECT No. 123-94128 | | | FILE No. 12394128A002 | | | |
| SCALE | | | NTS | | | |
|  | | | FIG-2 | | | |

**APPENDIX A
BORING LOGS**



500 Century Plaza Drive, Suite 190
Houston, Texas 77073
Telephone: (281) 821-6868
Fax: (281) 821-6870

BORING NUMBER BH-1

PAGE 1 OF 2

CLIENT Luminant
PROJECT NUMBER 123-94128
DATE STARTED 10/15/12 COMPLETED 10/15/12
DRILLING CONTRACTOR Van & Sons Drilling Service
DRILLING METHOD Mud Rotary
LOGGED BY HR CHECKED BY PCM
NOTES _____

PROJECT NAME Pond Slope Stability
PROJECT LOCATION Big Brown Plant
GROUND ELEVATION _____ HOLE SIZE inches
GROUND WATER LEVELS:
AT TIME OF DRILLING ---
AT END OF DRILLING ---
▼ AFTER DRILLING 20.00 ft

GEOTECH BH PLOTS - GINT STD US LAB.GDT - 11/20/12 15:09 - P.1 2012 PROJECT FOLDERS\123-94128 LUMINANT POND SLOPE STABILITY\BIG BROWN FIELD INVESTIGATION\94128BIGBROWN.GPJ

| DEPTH (ft) | GRAPHIC LOG | MATERIAL DESCRIPTION | SAMPLE TYPE NUMBER | RECOVERY % (RQD) | BLOW COUNTS (N VALUE) | POCKET PEN. (tsf) | DRY UNIT WT. (pcf) | ▲ SPT N VALUE ▲ | | | |
|------------|-------------|--|--------------------|------------------|-----------------------|-------------------|--------------------|-----------------------|----|----|--|
| | | | | | | | | PL | MC | LL | |
| | | | | | | | | □ FINES CONTENT (%) □ | | | |
| 0 | | (SC) CLAYEY SAND, medium to fine, well graded, light brown, and low plasticity clay, moist | | | | | | | | | |
| 3.5 | | sandy clay lenses, dry at 3.5' | SH 1 | 78 | | 3.0 | | | | | |
| 4.9 | | no clay lenses at 6.0' | SH 2 | | | 4.9 | | | | | |
| 4.5 | | | SH 3 | 78 | | 4.5 | | | | | |
| 4.5 | | (CL) LEAN CLAY, low plasticity, with sand, brown-orange, cohesive, dry | SH 4 | | | 4.5 | | | | | |
| 15 | | (SC) CLAYEY SAND, medium to fine, well graded, brown to orange, and low plasticity clay, moist | SH 5 | 65 | | | | | | | |
| 20 | | ▼ | SH 6 | 79 | | 1.5 | | | | | |
| 23.0 | | gray at 23.0' | SH 7 | 83 | | | | | | | |
| 30 | | (CL) LEAN CLAY, low plasticity, some fine to medium sand, gray to brown, cohesive, moist | SH 8 | 79 | | | | | | | |
| 35 | | | SH 9 | 83 | | | | | | | |

(Continued Next Page)

US EPA ARCHIVE DOCUMENT



500 Century Plaza Drive, Suite 190
Houston, Texas 77073
Telephone: (281) 821-6868
Fax: (281) 821-6870

BORING NUMBER BH-1

CLIENT Luminant PROJECT NAME Pond Slope Stability
PROJECT NUMBER 123-94128 PROJECT LOCATION Big Brown Plant

GEOTECH BH PLOTS - GINT STD US LAB.GDT - 11/20/12 15:09 - P:_2012 PROJECT FOLDERS\123-94128 LUMINANT POND SLOPE STABILITY\BIG BROWN FIELD INVESTIGATION\94128BIGBROWN.GPJ

| DEPTH (ft) | GRAPHIC LOG | MATERIAL DESCRIPTION | SAMPLE TYPE NUMBER | RECOVERY % (RQD) | BLOW COUNTS (N VALUE) | POCKET PEN. (tsf) | DRY UNIT WT. (pcf) | ▲ SPT N VALUE ▲ | | | | |
|------------|-------------|---|--------------------|------------------|-----------------------|-------------------|--------------------|-----------------------|----|----|----|--|
| | | | | | | | | 20 | 40 | 60 | 80 | |
| | | | | | | | | PL | MC | LL | | |
| | | | | | | | | 20 | 40 | 60 | 80 | |
| | | | | | | | | □ FINES CONTENT (%) □ | | | | |
| | | | | | | | | 20 | 40 | 60 | 80 | |
| 35 | | (CL) LEAN CLAY, low plasticity, some fine to medium sand, gray to brown, cohesive, moist (<i>continued</i>) | | | | | | | | | | |
| 40 | | (SC) CLAYEY SAND, medium to fine, well graded, with low plasticity clay, brown, wet | SS 10 | 83 | 12-13-14 (27) | | | | | | | |
| 45 | | | SS 11 | 100 | 5-5-3 (8) | | | | | | | |
| 50 | | | SS 12 | 100 | 8-9-11 (20) | | | | | | | |

Bottom of borehole at 50.0 feet.

US EPA ARCHIVE DOCUMENT



500 Century Plaza Drive, Suite 190
Houston, Texas 77073
Telephone: (281) 821-6868
Fax: (281) 821-6870

BORING NUMBER BH-2

PAGE 1 OF 2

CLIENT Luminant
PROJECT NUMBER 123-94128
DATE STARTED 10/16/12 **COMPLETED** 10/16/12
DRILLING CONTRACTOR Van & Sons Drilling Service
DRILLING METHOD Mud Rotary
LOGGED BY HR **CHECKED BY** PCM
NOTES _____

PROJECT NAME Pond Slope Stability
PROJECT LOCATION Big Brown Plant
GROUND ELEVATION _____ **HOLE SIZE** inches
GROUND WATER LEVELS:
AT TIME OF DRILLING ---
AT END OF DRILLING ---
AFTER DRILLING ---

GEOTECH BH PLOTS - GINT STD US LAB.GDT - 11/20/12 15:09 - P:\2012 PROJECT FOLDERS\123-94128 LUMINANT POND SLOPE STABILITY\BIG BROWN FIELD INVESTIGATION\94128BIGBROWN.GPJ

| DEPTH (ft) | GRAPHIC LOG | MATERIAL DESCRIPTION | SAMPLE TYPE NUMBER | RECOVERY % (RQD) | BLOW COUNTS (N VALUE) | POCKET PEN. (tsf) | DRY UNIT WT. (pcf) | ▲ SPT N VALUE ▲ | | | |
|------------|-------------|---|--------------------|------------------|-----------------------|-------------------|--------------------|-----------------------|----|----|----|
| | | | | | | | | PL | MC | LL | |
| | | | | | | | | □ FINES CONTENT (%) □ | | | |
| | | | | | | | | 20 | 40 | 60 | 80 |
| 0 | | | | | | | | | | | |
| 0 - 5 | | (CL) LEAN CLAY, low plasticity, with sand and gravel, decreasing coarse content with depth, dry, gray and brown | SH 1 | 58 | | 4.5 | | | | | |
| 5 | | | SH 2 | 75 | | 4.5 | | | | | |
| 5 - 10 | | (SC) CLAYEY SAND, medium to fine, well graded, with low plasticity clay, brown, moist | SH 3 | 100 | | 4.5 | | | | | |
| 10 | | | SH 4 | 50 | | 3.0 | | | | | |
| 10 - 15 | | | SH 5 | 67 | | 4.5 | | | | | |
| 15 - 20 | | decreasing clay with depth at 18.0' | SH 6 | 44 | | 2.25 | | | | | |
| 20 - 25 | | | SH 7 | 94 | | 4.5 | | | | | |
| 25 - 30 | | gray and orange at 28.0' | SH 8 | 88 | | 4.5 | | | | | |
| 30 - 35 | | | SH 9 | 90 | | 2.5 | | | | | |

(Continued Next Page)

US EPA ARCHIVE DOCUMENT



500 Century Plaza Drive, Suite 190
Houston, Texas 77073
Telephone: (281) 821-6868
Fax: (281) 821-6870

BORING NUMBER BH-2

CLIENT Luminant PROJECT NAME Pond Slope Stability

PROJECT NUMBER 123-94128 PROJECT LOCATION Big Brown Plant

GEOTECH BH PLOTS - GINT STD US LAB.GDT - 11/20/12 15:09 - P:_2012 PROJECT FOLDERS\123-94128 LUMINANT POND SLOPE STABILITY\BIG BROWN FIELD INVESTIGATION\94128BIGBROWN.GPJ

| DEPTH (ft) | GRAPHIC LOG | MATERIAL DESCRIPTION | SAMPLE TYPE NUMBER | RECOVERY % (RQD) | BLOW COUNTS (N VALUE) | POCKET PEN. (tsf) | DRY UNIT WT. (pcf) | ▲ SPT N VALUE ▲ | |
|------------|-------------|---|--------------------|------------------|-----------------------|-------------------|--------------------|-----------------------|----------|
| | | | | | | | | PL | MC LL |
| | | | | | | | | □ FINES CONTENT (%) □ | |
| | | | | | | | | 20 | 40 60 80 |
| 35 | | (SC) CLAYEY SAND, medium to fine, well graded, with low plasticity clay, brown, moist (continued) | | | | | | | |
| | | wet at 38.5' | | | | | | | |
| 40 | | | SS 10 | 56 | 15-18-20 (38) | | | | |
| 45 | | | SS 11 | 100 | 3-3-5 (8) | | | | |
| 50 | | | SS 12 | 100 | 18-18-17 (35) | | | | |

Bottom of borehole at 50.0 feet.

US EPA ARCHIVE DOCUMENT



500 Century Plaza Drive, Suite 190
Houston, Texas 77073
Telephone: (281) 821-6868
Fax: (281) 821-6870

BORING NUMBER BH-3

PAGE 1 OF 1

CLIENT Luminant
PROJECT NUMBER 123-94128
DATE STARTED 10/15/12 **COMPLETED** 10/15/12
DRILLING CONTRACTOR Van & Sons Drilling Service
DRILLING METHOD Mud Rotary
LOGGED BY HR **CHECKED BY** PCM
NOTES _____

PROJECT NAME Pond Slope Stability
PROJECT LOCATION Big Brown Plant
GROUND ELEVATION _____ **HOLE SIZE** inches
GROUND WATER LEVELS:
AT TIME OF DRILLING ---
AT END OF DRILLING ---
AFTER DRILLING ---

GEOTECH BH PLOTS - GINT STD US LAB.GDT - 11/20/12 15:09 - P:\2012 PROJECT FOLDERS\123-94128 LUMINANT POND SLOPE STABILITY\BIG BROWN FIELD INVESTIGATION\94128BIGBROWN.GPJ

| DEPTH (ft) | GRAPHIC LOG | MATERIAL DESCRIPTION | SAMPLE TYPE NUMBER | RECOVERY % (RQD) | BLOW COUNTS (N VALUE) | POCKET PEN. (tsf) | DRY UNIT WT. (pcf) | ▲ SPT N VALUE ▲ | | | | |
|---------------|-------------|--|--------------------|------------------|-----------------------|-------------------|--------------------|-----------------|----|----|----|--|
| | | | | | | | | 20 | 40 | 60 | 80 | |
| 0 | | (SC) CLAYEY SAND, medium to fine, some gravel, brown, moist | | | | | | | | | | |
| 2.5 | | | SH 1 | 56 | | 2.5 | | | | | | |
| 5 | | increasing clay content and clay lenses at 3.5' | | | | | | | | | | |
| 4.5 | | | SH 2 | 67 | | 4.5 | | | | | | |
| 7.5 | | (CL) LEAN CLAY, low plasticity, and well graded, medium to fine sand, light brown, moist | | | | | | | | | | |
| 4.5 | | | SH 3 | 72 | | 4.5 | | | | | | |
| 10 | | | SH 4 | 89 | | 4.5 | | | | | | |
| 15 | | | SH 5 | 81 | | 4.5 | | | | | | |
| 20 | | (SC) CLAYEY SAND, medium to fine, brown, moist | | | | | | | | | | |
| 4.0 | | | SH 6 | 75 | | 4.0 | | | | | | |
| 25 | | (SP) SAND, poorly graded, medium, tan, moist | | | | | | | | | | |
| 13-18-18 (36) | | | SS 7 | 89 | 13-18-18 (36) | | | | | | | |
| 13-24-30 (54) | | | SS 8 | 100 | 13-24-30 (54) | | | | | | | |
| 30 | | Bottom of borehole at 30.0 feet. | | | | | | | | | | |

US EPA ARCHIVE DOCUMENT



500 Century Plaza Drive, Suite 190
Houston, Texas 77073
Telephone: (281) 821-6868
Fax: (281) 821-6870

BORING NUMBER BH-4

PAGE 1 OF 1

CLIENT Luminant
PROJECT NUMBER 123-94128
DATE STARTED 10/16/12 **COMPLETED** 10/16/12
DRILLING CONTRACTOR Van & Sons Drilling Service
DRILLING METHOD Mud Rotary
LOGGED BY HR **CHECKED BY** PCM
NOTES _____

PROJECT NAME Pond Slope Stability
PROJECT LOCATION Big Brown Plant
GROUND ELEVATION _____ **HOLE SIZE** inches
GROUND WATER LEVELS:
AT TIME OF DRILLING ---
AT END OF DRILLING ---
AFTER DRILLING ---

GEOTECH BH PLOTS - GINT STD US LAB.GDT - 11/20/12 15:09 - P:\2012 PROJECT FOLDERS\BIG BROWN FIELD INVESTIGATION\94128\BIGBROWN.GPJ

| DEPTH (ft) | GRAPHIC LOG | MATERIAL DESCRIPTION | SAMPLE TYPE NUMBER | RECOVERY % (RQD) | BLOW COUNTS (N VALUE) | POCKET PEN. (tsf) | DRY UNIT WT. (pcf) | ▲ SPT N VALUE ▲ | | |
|------------|-------------|---|--------------------|------------------|-----------------------|-------------------|--------------------|-----------------|----|----|
| | | | | | | | | 20 | 40 | 60 |
| 0 | | | | | | | | | | |
| 0 - 15 | | (SC) CLAYEY SAND, medium to fine, well graded, and low plasticity clay, moist dry at 3.5' moist at 6.0' | SH 1 | 56 | | 4.5 | | | | |
| 5 | | | SH 2 | 67 | | 4.5 | | | | |
| 10 | | | SH 3 | 72 | | 4.5 | | | | |
| 15 | | (CL) LEAN CLAY, low plasticity, with medium to fine sand, gray - brown, moist, cohesive | SH 5 | 83 | | 1.5 | | | | |
| 20 | | (SC) CLAYEY SAND, medium to fine, well graded, and low plasticity clay, moist | SH 6 | 54 | | 1.5 | | | | |
| 25 | | | SH 7 | 58 | | 2 | | | | |
| 30 | | | SH 8 | 92 | | 1.0 | | | | |

Bottom of borehole at 30.0 feet.

US EPA ARCHIVE DOCUMENT



500 Century Plaza Drive, Suite 190
Houston, Texas 77073
Telephone: (281) 821-6868
Fax: (281) 821-6870

BORING NUMBER BH-5

CLIENT Luminant
PROJECT NUMBER 123-94128
DATE STARTED 10/16/12 **COMPLETED** 1/16/12
DRILLING CONTRACTOR Van & Sons Drilling Service
DRILLING METHOD Mud Rotary
LOGGED BY HR **CHECKED BY** PCM
NOTES _____

PROJECT NAME Pond Slope Stability
PROJECT LOCATION Big Brown Plant
GROUND ELEVATION _____ **HOLE SIZE** inches
GROUND WATER LEVELS:
AT TIME OF DRILLING --
AT END OF DRILLING --
AFTER DRILLING --

GEO TECH BH PLOTS - GINT STD US LAB.GDT - 11/20/12 15:09 - P.1 2012 PROJECT FOLDERS\123-94128 LUMINANT POND SLOPE STABILITY\BIG BROWN FIELD INVESTIGATION\94128\BIGBROWN.GPJ

US EPA ARCHIVE DOCUMENT

| DEPTH (ft) | GRAPHIC LOG | MATERIAL DESCRIPTION | SAMPLE TYPE NUMBER | RECOVERY % (RQD) | BLOW COUNTS (N VALUE) | POCKET PEN. (tsf) | DRY UNIT WT. (pcf) | ▲ SPT N VALUE ▲ | | | | | | |
|------------|-------------|---|--------------------|------------------|-----------------------|-------------------|--------------------|-----------------|----|----|----|--|--|--|
| | | | | | | | | 20 | 40 | 60 | 80 | | | |
| 0 | | | | | | | | | | | | | | |
| 4.5 | | (CL) SANDY LEAN CLAY, low plasticity, medium to fine, well graded, brown and orange, cohesive, moist | SH 1 | 78 | | 4.5 | | | | | | | | |
| 5 | | trace gravel, red and gray at 3.5' | SH 2 | 78 | | 4.5 | | | | | | | | |
| 7.5 | | (SC) CLAYEY SAND, medium to fine, well graded, some low plasticity clay, orange, cohesive, moist | SH 3 | 100 | | 2.25 | | | | | | | | |
| 10 | | (CL) SANDY LEAN CLAY, low plasticity, medium to fine, well graded, brown and orange, cohesive, moist | SH 4 | 89 | | 0.75 | | | | | | | | |
| 10 | | (SC) CLAYEY SAND, medium to fine, well graded, some low plasticity clay, gray to brown, non-cohesive, moist | | | | | | | | | | | | |
| 15 | | (CL) SANDY LEAN CLAY, low plasticity, medium to fine, well graded, gray and brown, cohesive, moist | SH 5 | 75 | | 3.25 | | | | | | | | |
| 20 | | (SW) WELL GRADED SAND, medium to fine, with low plasticity clay lenses, orange, non-cohesive, moist | SH 6 | 52 | | 3.0 | | | | | | | | |
| 25 | | (CH) SANDY FAT CLAY, high plasticity, medium to fine, well graded, gray, cohesive, moist | SH 7 | 83 | | 2.75 | | | | | | | | |
| 30 | | (CL) SANDY LEAN CLAY, low plasticity, medium to fine, well graded, gray, cohesive, moist | SH 8 | 73 | | 4.5 | | | | | | | | |
| 30 | | orange and gray at 28.0' | | | | | | | | | | | | |
| 35 | | (SC) CLAYEY SAND, medium to fine, well graded, some low plasticity clay, gray and orange, cohesive, moist | SH 9 | 67 | | 4.25 | | | | | | | | |

(Continued Next Page)



500 Century Plaza Drive, Suite 190
Houston, Texas 77073
Telephone: (281) 821-6868
Fax: (281) 821-6870

BORING NUMBER BH-5

PAGE 2 OF 2

CLIENT Luminant PROJECT NAME Pond Slope Stability

PROJECT NUMBER 123-94128 PROJECT LOCATION Big Brown Plant

GEOTECH BH PLOTS - GINT STD US LAB.GDT - 11/20/12 15:09 - P:_2012 PROJECT FOLDERS\123-94128 LUMINANT POND SLOPE STABILITY\BIG BROWN FIELD INVESTIGATION\94128BIGBROWN.GPJ

| DEPTH (ft) | GRAPHIC LOG | MATERIAL DESCRIPTION | SAMPLE TYPE NUMBER | RECOVERY % (RQD) | BLOW COUNTS (N VALUE) | POCKET PEN. (tsf) | DRY UNIT WT. (pcf) | ▲ SPT N VALUE ▲ | |
|------------|-------------|---|--------------------|------------------|-----------------------|-------------------|--------------------|-----------------------|-------------|
| | | | | | | | | PL | MC LL |
| | | | | | | | | □ FINES CONTENT (%) □ | |
| | | | | | | | | 20 40 60 80 | 20 40 60 80 |
| 35 | | (SC) CLAYEY SAND, medium to fine, well graded, some low plasticity clay, gray and orange, cohesive, moist (continued) | | | | | | | |
| 40 | | | SS 10 | 100 | 13-15-16 (31) | | | | |
| 45 | | wet at 43.5' | SS 11 | 100 | 4-5-5 (10) | | | | |
| 50 | | | SS | | 10-10-12 (22) | | | | |

Bottom of borehole at 50.0 feet.

US EPA ARCHIVE DOCUMENT



500 Century Plaza Drive, Suite 190
Houston, Texas 77073
Telephone: (281) 821-6868
Fax: (281) 821-6870

BORING NUMBER BH-6

CLIENT Luminant
PROJECT NUMBER 123-94128
DATE STARTED 10/16/12 **COMPLETED** 10/16/12
DRILLING CONTRACTOR Van & Sons Drilling Service
DRILLING METHOD Mud Rotary
LOGGED BY HR **CHECKED BY** PCM
NOTES _____

PROJECT NAME Pond Slope Stability
PROJECT LOCATION Big Brown Plant
GROUND ELEVATION _____ **HOLE SIZE** inches
GROUND WATER LEVELS:
AT TIME OF DRILLING ---
AT END OF DRILLING ---
AFTER DRILLING ---

GEOTECH BH PLOTS - GINT STD US LAB.GDT - 11/20/12 15:10 - P:\2012 PROJECT FOLDERS\123-94128 LUMINANT POND SLOPE STABILITY\BIG BROWN FIELD INVESTIGATION\94128BIGBROWN.GPJ

US EPA ARCHIVE DOCUMENT

| DEPTH (ft) | GRAPHIC LOG | MATERIAL DESCRIPTION | SAMPLE TYPE NUMBER | RECOVERY % (RQD) | BLOW COUNTS (N VALUE) | POCKET PEN. (tsf) | DRY UNIT WT. (pcf) | ▲ SPT N VALUE ▲ | | | | |
|------------|-------------|---|--------------------|------------------|-----------------------|-------------------|--------------------|-----------------|----|----|----|--|
| | | | | | | | | 20 | 40 | 60 | 80 | |
| 0 | | (SC) CLAYEY SAND, medium to fine, well graded, some low plasticity clay, brown, cohesive, moist | SH 1 | 28 | | | | | | | | |
| 5 | | and low plasticity clay at 3.5' | SH 2 | 67 | | 4.5 | | | | | | |
| | | (CL) SANDY LEAN CLAY, low plasticity, some medium to fine sand, orange, wet (SW) WELL GRADED SAND, medium to fine, gray, dry | SH 3 | 72 | | 0.0 | | | | | | |
| 10 | | (SC) CLAYEY SAND, medium to fine, well graded, and low plasticity clay, orange, dry, cohesive | SH 4 | 61 | | 4.5 | | | | | | |
| 15 | | (CL) LEAN CLAY, low plasticity, some medium to fine sand, orange, moist, cohesive | SH 5 | 54 | | 4.5 | | | | | | |
| 20 | | (SC) CLAYEY SAND, medium to fine, well graded, and low plasticity clay, gray, moist, cohesive | SS 6 | 54 | 5-7-10 (17) | | | | | | | |
| 25 | | (CL) SANDY LEAN CLAY, low plasticity, increasing sand with depth, gray, cohesive, moist | SH 7 | 100 | | 2.0 | | | | | | |
| 30 | | (SC) CLAYEY SAND, medium to fine, well graded, and low plasticity clay, gray and orange, possible some lignite (black), moist, cohesive | SH 8 | 88 | | 3.5 | | | | | | |
| 35 | | no lignite at 33.0' | SH 9 | 69 | | 3.5 | | | | | | |

(Continued Next Page)



500 Century Plaza Drive, Suite 190
Houston, Texas 77073
Telephone: (281) 821-6868
Fax: (281) 821-6870

BORING NUMBER BH-6

PAGE 2 OF 2

CLIENT Luminant PROJECT NAME Pond Slope Stability
PROJECT NUMBER 123-94128 PROJECT LOCATION Big Brown Plant

GEOTECH BH PLOTS - GINT STD US LAB.GDT - 11/20/12 15:10 - P:_2012 PROJECT FOLDERS\123-94128 LUMINANT POND SLOPE STABILITY\BIG BROWN FIELD INVESTIGATION\94128BIGBROWN.GPJ

| DEPTH (ft) | GRAPHIC LOG | MATERIAL DESCRIPTION | SAMPLE TYPE NUMBER | RECOVERY % (RQD) | BLOW COUNTS (N VALUE) | POCKET PEN. (tsf) | DRY UNIT WT. (pcf) | ▲ SPT N VALUE ▲ | |
|------------|-------------|--|--------------------|------------------|-----------------------|-------------------|--------------------|-----------------------|-------------|
| | | | | | | | | PL | MC LL |
| | | | | | | | | 20 40 60 80 | 20 40 60 80 |
| | | | | | | | | □ FINES CONTENT (%) □ | |
| | | | | | | | | 20 40 60 80 | 20 40 60 80 |
| 35 | | (SC) CLAYEY SAND, medium to fine, well graded, and low plasticity clay, gray and orange, possible some lignite (black), moist, cohesive (<i>continued</i>) | | | | | | | |
| 40 | | (SW) WELL GRADED SAND, medium to fine, trace low plasticity clay lenses, gray, non-cohesive, moist | SH 10 | 60 | | 0.0 | | ● | □ |
| 45 | | orange, clay nodules at 43.0' | SH 11 | 50 | | 0.0 | | ● | |
| 50 | | with stiff, gray, clay nodules and lenses at 48.0' | SH 12 | 46 | | 0.0 | | ● | |

Bottom of borehole at 50.0 feet.

US EPA ARCHIVE DOCUMENT

**APPENDIX B
LABORATORY TEST SUMMARY SHEETS**



500 Century Plaza Drive, Suite 190
Houston, Texas 77073
Telephone: (281) 821-6868
Fax: (281) 821-6870

SUMMARY OF LABORATORY RESULTS

CLIENT Luminant

PROJECT NAME Pond Slope Stability

PROJECT NUMBER 123-94128

PROJECT LOCATION Big Brown Plant

| Sample ID | Depth | Natural Moisture (%) | Atterberg Limits | | | % <#200 Sieve | Class-ification | Unit Weight | | Permeability (cm/sec) | Additional Lab Testing |
|-----------|-------|----------------------|------------------|---------------|------------------|---------------|-----------------|----------------------|-------------------|-----------------------|------------------------|
| | | | Liquid Limit | Plastic Limit | Plasticity Index | | | Moisture Content (%) | Dry Density (psf) | | |
| BH-1 | 1 | 19.3 | | | | | | | | | |
| BH-1 | 4 | 11.9 | | | | | | | | | |
| BH-1 | 6 | 8.8 | | | | | | | | | |
| BH-1 | 9 | 13.6 | | | | | | | | | |
| BH-1 | 13 | 19.1 | | | | | | | | | |
| BH-1 | 18 | 15.5 | | | | | | | | | |
| BH-1 | 23 | 15.4 | | | | | | | | | |
| BH-1 | 28 | 19.9 | 33 | 13 | 20 | | | | | | |
| BH-1 | 33 | 16.0 | | | | | | | | | |
| BH-1 | 39 | 22.9 | | | | | | | | | |
| BH-1 | 44 | 25.6 | | | | | | | | | |
| BH-1 | 49 | 27.6 | | | | | | | | | |
| BH-2 | 1 | 20.1 | | | | | | | | | |
| BH-2 | 4 | 13.3 | | | | | | | | | |
| BH-2 | 6 | 16.2 | | | | | | | | | |
| BH-2 | 9 | 9.9 | | | | | | | | | |
| BH-2 | 13 | 18.3 | | | | | | | | | |
| BH-2 | 18 | 17.9 | | | | | | | | | |
| BH-2 | 23 | 15.0 | | | | | | | | | |
| BH-2 | 28 | 17.2 | 34 | 17 | 17 | | | | | | |
| BH-2 | 33 | 22.5 | | | | | | | | | |
| BH-2 | 39 | 24.2 | | | | | | | | | |
| BH-2 | 44 | 26.1 | | | | | | | | | |
| BH-2 | 49 | 25.6 | | | | | | | | | |
| BH-3 | 1 | 12.2 | | | | | | | | | |
| BH-3 | 4 | 17.3 | | | | | | | | | |
| BH-3 | 6 | 16.7 | | | | | | | | | |
| BH-3 | 9 | 18.6 | | | | | | | | | |
| BH-3 | 13 | 18.7 | | | | | | | | | |
| BH-3 | 18 | 14.1 | | | | | | | | | |
| BH-3 | 24 | 8.5 | | | | | | | | | |
| BH-3 | 29 | 7.0 | | | | 17 | | | | | |
| BH-4 | 1 | 9.9 | | | | | | | | | |
| BH-4 | 4 | 11.4 | | | | | | | | | |
| BH-4 | 6 | 10.7 | | | | | | | | | |
| BH-4 | 9 | 22.0 | | | | | | | | | |
| BH-4 | 13 | 20.1 | 39 | 16 | 23 | | | | | | |
| BH-4 | 18 | 15.7 | | | | | | | | | |
| BH-4 | 23 | 14.3 | | | | | | | | | |
| BH-4 | 28 | 20.3 | | | | | | | | | |
| BH-5 | 1 | 17.8 | | | | | | | | | |

LAB SUMMARY - CQA - GINT STD US LAB.GDT - 11/15/12 17:09 - P1_2012 PROJECT FOLDERS\123-94128 LUMINANT POND SLOPE STABILITY\BIG BROWN FIELD INVESTIGATION\94128BIGBROWN.GPJ

US EPA ARCHIVE DOCUMENT



500 Century Plaza Drive, Suite 190
Houston, Texas 77073
Telephone: (281) 821-6868
Fax: (281) 821-6870

SUMMARY OF LABORATORY RESULTS

CLIENT Luminant

PROJECT NAME Pond Slope Stability

PROJECT NUMBER 123-94128

PROJECT LOCATION Big Brown Plant

| Sample ID | Depth | Natural Moisture (%) | Atterberg Limits | | | % <#200 Sieve | Class-ification | Unit Weight | | Permeability (cm/sec) | Additional Lab Testing |
|-----------|-------|----------------------|------------------|---------------|------------------|---------------|-----------------|----------------------|-------------------|-----------------------|------------------------|
| | | | Liquid Limit | Plastic Limit | Plasticity Index | | | Moisture Content (%) | Dry Density (psf) | | |
| BH-5 | 4 | 20.3 | | | | | | | | | |
| BH-5 | 6 | 20.0 | 43 | 15 | 28 | | | | | | |
| BH-5 | 9 | 20.8 | | | | | | | | | |
| BH-5 | 13 | 18.3 | | | | | | | | | |
| BH-5 | 18 | 14.2 | | | | | | | | | |
| BH-5 | 23 | 19.6 | 60 | 14 | 46 | | | | | | |
| BH-5 | 28 | 15.7 | | | | | | | | | |
| BH-5 | 33 | 14.8 | | | | | | | | | |
| BH-5 | 39 | 19.6 | | | | | | | | | |
| BH-5 | 44 | 22.5 | | | | | | | | | |
| BH-5 | 49 | 20.9 | | | | | | | | | |
| BH-6 | 1 | 16.5 | | | | | | | | | |
| BH-6 | 4 | 11.9 | | | | | | | | | |
| BH-6 | 6 | 28.2 | | | | | | | | | |
| BH-6 | 9 | 12.3 | | | | | | | | | |
| BH-6 | 13 | 17.7 | 49 | 16 | 33 | | | | | | |
| BH-6 | 19 | 20.6 | | | | | | | | | |
| BH-6 | 23 | 19.3 | | | | | | | | | |
| BH-6 | 28 | 13.3 | | | | | | | | | |
| BH-6 | 33 | 21.9 | 44 | 14 | 30 | | | | | | |
| BH-6 | 38 | 21.5 | | | | 69 | | | | | |
| BH-6 | 43 | 26.0 | | | | | | | | | |
| BH-6 | 48 | 31.1 | | | | | | | | | |

LAB SUMMARY - CQA - GINT STD US LAB.GDT - 11/15/12 17:09 - P:_2012 PROJECT FOLDERS\123-94128 LUMINANT POND SLOPE STABILITY\BIG BROWN FIELD INVESTIGATION\94128BIGBROWN.GPJ

US EPA ARCHIVE DOCUMENT

**APPENDIX C
LABORATORY TEST RESULTS**

ATTERBERG LIMIT RESULTS



500 Century Plaza Drive, Suite 190
Houston, Texas 77073
Telephone: (281) 821-6868
Fax: (281) 821-6870

ATTERBERG LIMITS' RESULTS

CLIENT Luminant

PROJECT NAME Pond Slope Stability

PROJECT NUMBER 123-94128

PROJECT LOCATION Big Brown Plant

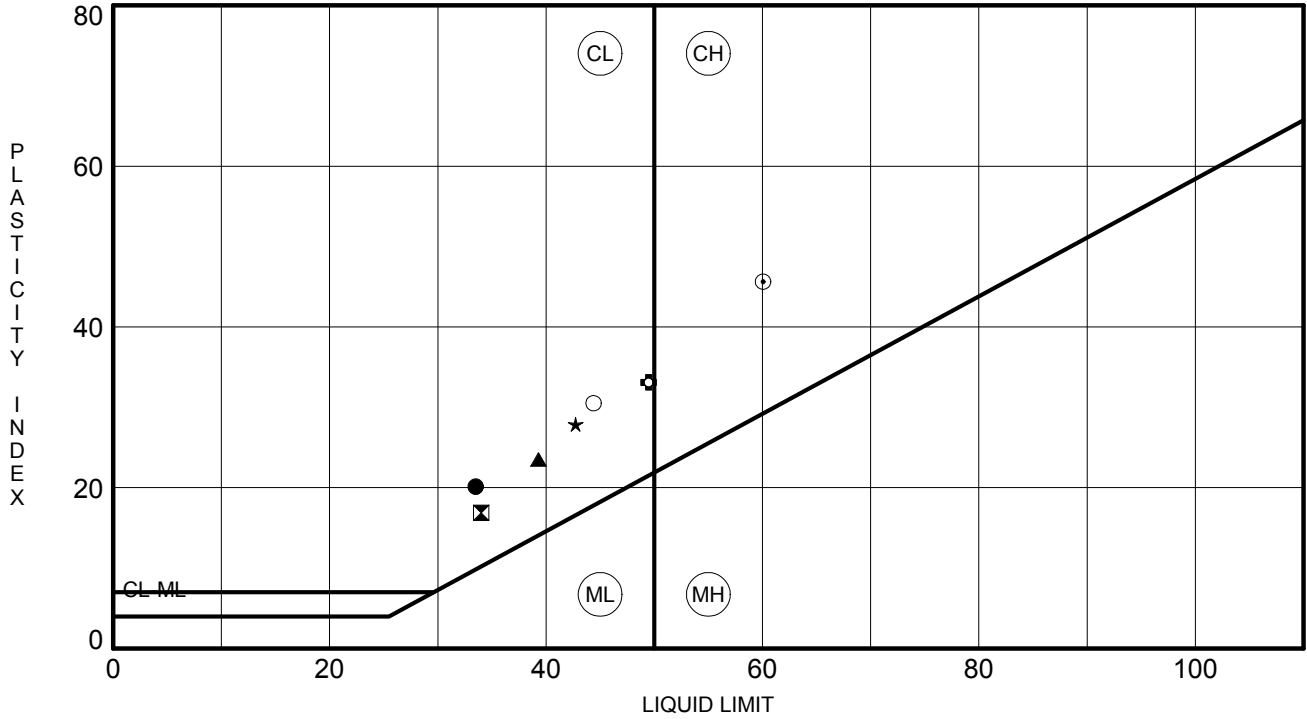

| BOREHOLE | DEPTH | LL | PL | PI | Fines | Classification |
|----------|-------|----|----|----|-------|----------------|
| ● BH-1 | 28.0 | 33 | 13 | 20 | | |
| ⊠ BH-2 | 28.0 | 34 | 17 | 17 | | |
| ▲ BH-4 | 13.0 | 39 | 16 | 23 | | |
| ★ BH-5 | 6.0 | 43 | 15 | 28 | | |
| ⊙ BH-5 | 23.0 | 60 | 14 | 46 | | |
| ⊕ BH-6 | 13.0 | 49 | 16 | 33 | | |
| ○ BH-6 | 33.0 | 44 | 14 | 30 | | |
| | | | | | | |
| | | | | | | |
| | | | | | | |
| | | | | | | |
| | | | | | | |
| | | | | | | |
| | | | | | | |
| | | | | | | |
| | | | | | | |
| | | | | | | |
| | | | | | | |
| | | | | | | |
| | | | | | | |
| | | | | | | |
| | | | | | | |
| | | | | | | |
| | | | | | | |
| | | | | | | |
| | | | | | | |
| | | | | | | |
| | | | | | | |
| | | | | | | |
| | | | | | | |
| | | | | | | |
| | | | | | | |

US EPA ARCHIVE DOCUMENT

ATTERBERG LIMITS - GINT STD US LAB.GDT - 11/15/12 17:07 - P1_2012 PROJECT FOLDERS\123-94128 LUMINANT POND SLOPE STABILITY\BIG BROWN FIELD INVESTIGATION\94128\BIGBROWN.GPJ

GRAIN SIZE ANALYSIS



500 Century Plaza Drive, Suite 190
Houston, Texas 77073
Telephone: (281) 821-6868
Fax: (281) 821-6870

GRAIN SIZE DISTRIBUTION

CLIENT Luminant

PROJECT NAME Pond Slope Stability

PROJECT NUMBER 123-94128

PROJECT LOCATION Big Brown Plant

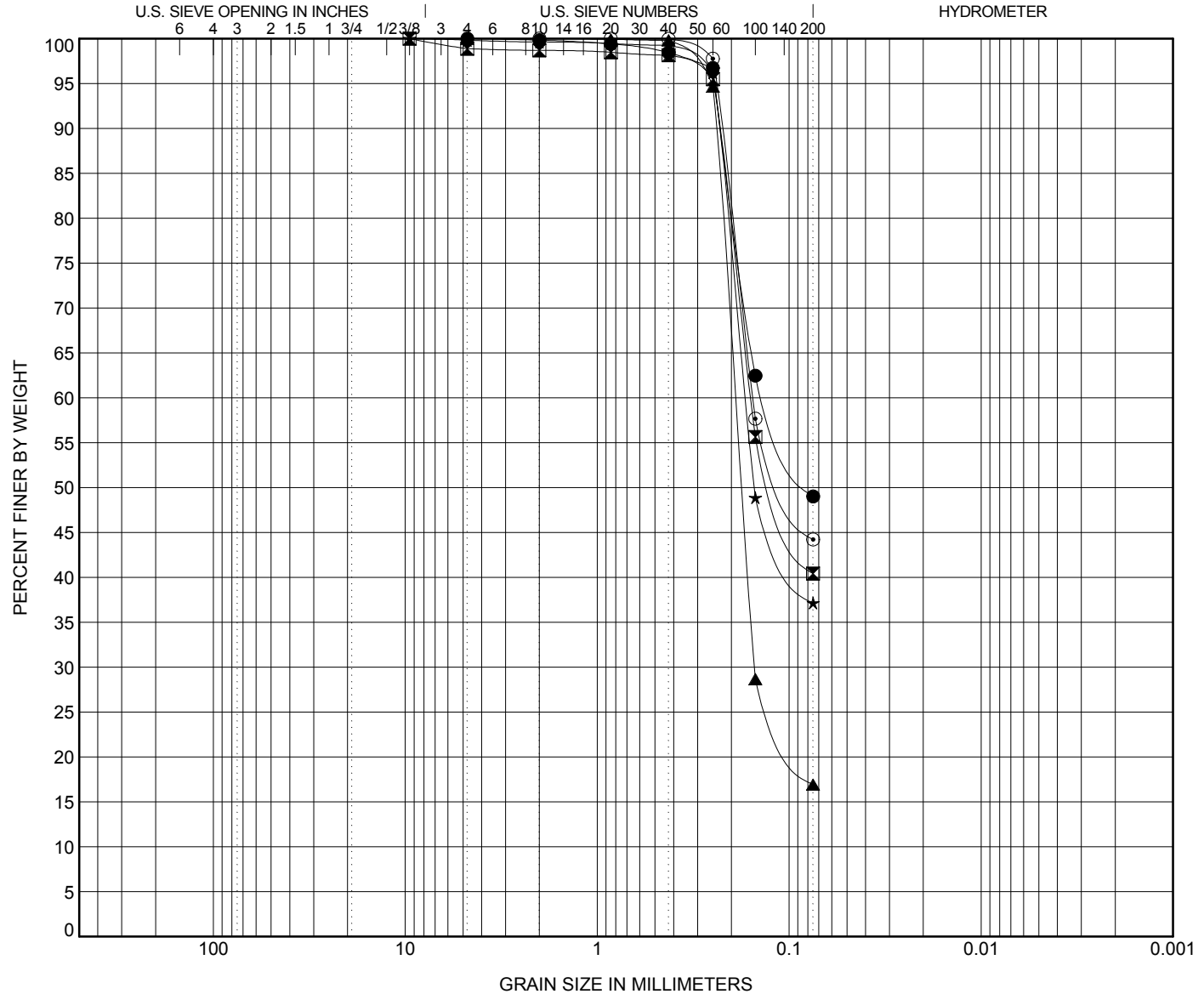

| COBBLES | GRAVEL | | SAND | | | SILT OR CLAY |
|---------|--------|------|--------|--------|------|--------------|
| | coarse | fine | coarse | medium | fine | |

| BOREHOLE | DEPTH | Classification | | | | | LL | PL | PI | Cc | Cu |
|----------|-------|----------------|-------|-------|-----|---------|-------|-------|-------|----|----|
| ● BH-1 | 6 | | | | | | | | | | |
| ☒ BH-2 | 39 | | | | | | | | | | |
| ▲ BH-3 | 29 | | | | | | | | | | |
| ★ BH-4 | 18 | | | | | | | | | | |
| ◎ BH-5 | 33 | | | | | | | | | | |
| BOREHOLE | DEPTH | D100 | D60 | D30 | D10 | %Gravel | %Sand | %Silt | %Clay | | |
| ● BH-1 | 6 | 4.75 | 0.132 | | | 0.0 | 51.0 | | 49.0 | | |
| ☒ BH-2 | 39 | 9.5 | 0.159 | | | 1.1 | 58.5 | | 40.4 | | |
| ▲ BH-3 | 29 | 4.75 | 0.191 | 0.152 | | 0.0 | 83.1 | | 16.9 | | |
| ★ BH-4 | 18 | 9.5 | 0.169 | | | 0.2 | 62.7 | | 37.2 | | |
| ◎ BH-5 | 33 | 2 | 0.155 | | | 0.0 | 55.8 | | 44.2 | | |

GRAIN SIZE - COA - GINT STD US LAB.GDT - 11/16/12 - 13:59 - P:_2012 PROJECT FOLDERS\BIG BROWN FIELD INVESTIGATION\94128\BIGBROWN.GPJ

US EPA ARCHIVE DOCUMENT



500 Century Plaza Drive, Suite 190
Houston, Texas 77073
Telephone: (281) 821-6868
Fax: (281) 821-6870

GRAIN SIZE DISTRIBUTION

CLIENT Luminant

PROJECT NAME Pond Slope Stability

PROJECT NUMBER 123-94128

PROJECT LOCATION Big Brown Plant

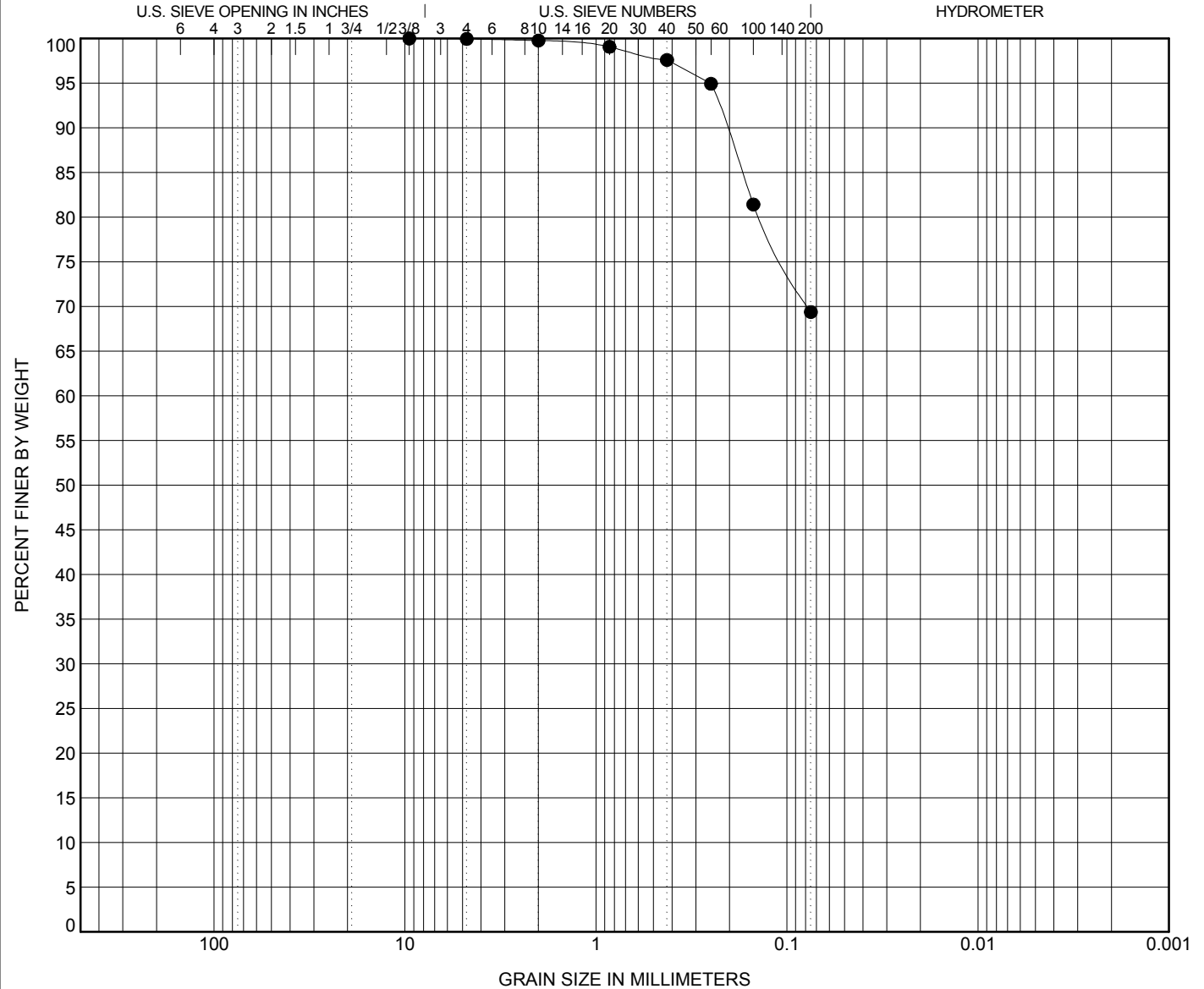

| COBBLES | GRAVEL | | SAND | | | SILT OR CLAY |
|---------|--------|------|--------|--------|------|--------------|
| | coarse | fine | coarse | medium | fine | |

| BOREHOLE | DEPTH | Classification | | | | | LL | PL | PI | Cc | Cu |
|----------|-------|----------------|--|--|--|--|----|----|----|----|----|
| ● BH-6 | 38 | | | | | | | | | | |

| BOREHOLE | DEPTH | D100 | D60 | D30 | D10 | %Gravel | %Sand | %Silt | %Clay |
|----------|-------|------|-----|-----|-----|---------|-------|-------|-------|
| ● BH-6 | 38 | 9.5 | | | | 0.1 | 30.6 | 69.4 | |

GRAIN SIZE - COA - GINT STD US LAB.GDT - 11/16/12 - 13:59 - P:_2012 PROJECT FOLDERS\BIG BROWN FIELD INVESTIGATION\94128\BIGBROWN.GPJ

US EPA ARCHIVE DOCUMENT

UNCONSOLIDATED / UNDRAINED COMPRESSIVE STRENGTH (UU)

UNCONSOLIDATED / UNDRAINED COMPRESSIVE STRENGTH
ASTM D 2850

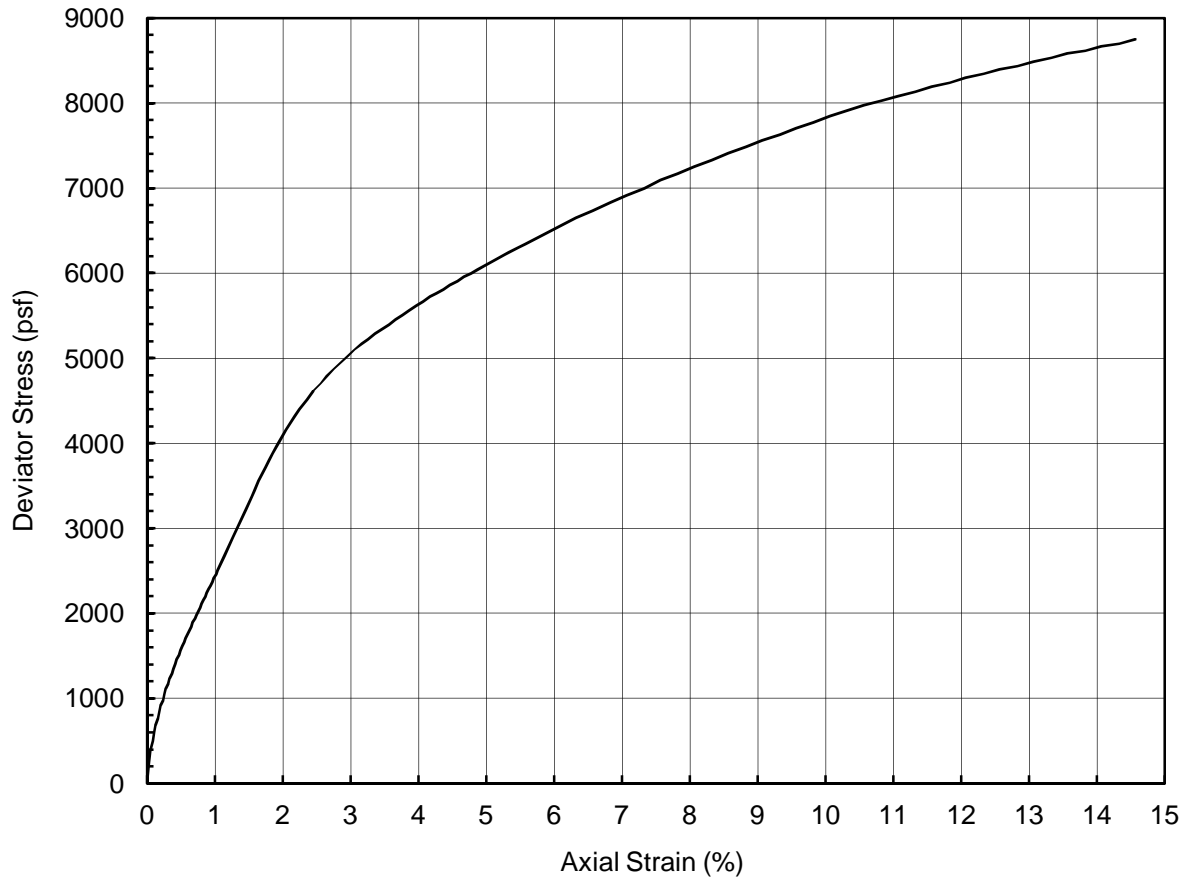

| | | | | | | | |
|----------------------|----|--------------------------------|----|----|-----|------|----|
| Specimen Description | | Light Tan and Gray Clayey Sand | | | | | |
| LL | 33 | PI | 20 | LI | 0.2 | USCS | CL |

| | | | |
|-------------------------------|--------|---------------------------------|------|
| Depth (ft) | 28.0 | Confining Pressure (psf) | 2879 |
| Specimen Height (inch) | 5.9 | Strain Rate (%/min) | 1.0 |
| Specimen Diameter (inch) | 2.8 | Peak Deviator Stress (psf) | 8784 |
| Initial Specimen Weight (g) | 1253.7 | Axial Strain at Peak Stress (%) | 15.0 |
| Moist Unit Weight (pcf) | 132.8 | | |
| Initial Water Content (%) | 17 | | |
| Initial Dry Unit Weight (pcf) | 113.3 | | |

| | |
|----------------|--------------------------------------|
| Project Title | Luminant - Big Brown Slope Stability |
| Project Number | 123-94128 |
| Sample Type | Shelby Tube |
| Sample ID | BH-2 TO-8 |
| Comments | |

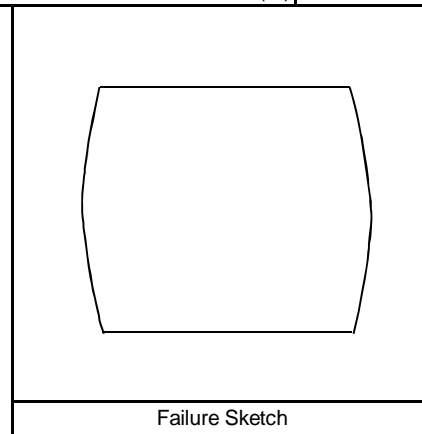

| | |
|--------------|----------|
| Performed by | PN |
| Date | 7-Nov-12 |
| Check | HR |
| Review | PCM |

**UNCONSOLIDATED / UNDRAINED COMPRESSIVE STRENGTH
ASTM D 2850**

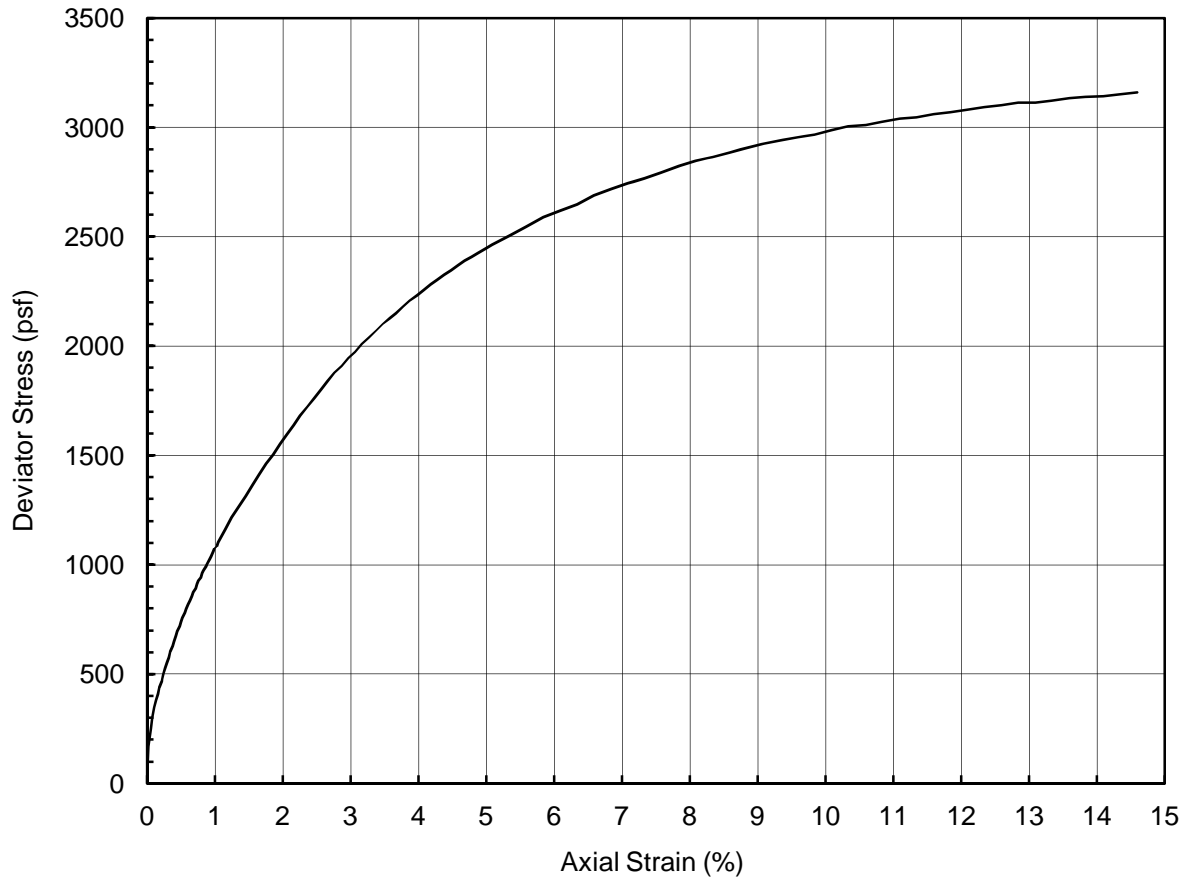

| | | | | | | | |
|----------------------|----|--------------------------------|----|----|-----|------|----|
| Specimen Description | | Light Tan and Gray Clayey Sand | | | | | |
| LL | 39 | PI | 23 | LI | 0.2 | USCS | CL |

| | | | |
|-------------------------------|-------|---------------------------------|------|
| Depth (ft) | 13.0 | Confining Pressure (psf) | 1754 |
| Specimen Height (inch) | 4.9 | Strain Rate (%/min) | 1.0 |
| Specimen Diameter (inch) | 2.8 | Peak Deviator Stress (psf) | 3164 |
| Initial Specimen Weight (g) | 950.5 | Axial Strain at Peak Stress (%) | 14.8 |
| Moist Unit Weight (pcf) | 121.4 | | |
| Initial Water Content (%) | 20 | | |
| Initial Dry Unit Weight (pcf) | 101.3 | | |

| | |
|----------------|--------------------------------------|
| Project Title | Luminant - Big Brown Slope Stability |
| Project Number | 123-94128 |
| Sample Type | Shelby Tube |
| Sample ID | BH-4 TO-5 |
| Comments | Sample L/D ratio < 2 |

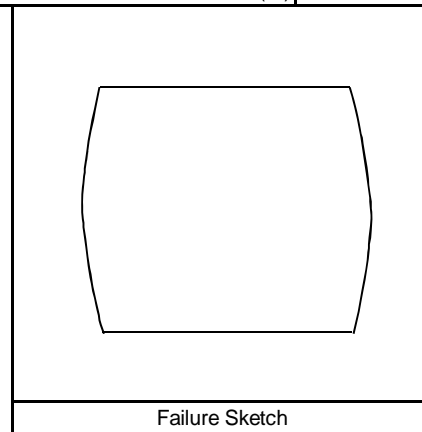

| | |
|--------------|----------|
| Performed by | PN |
| Date | 7-Nov-12 |
| Check | HR |
| Review | PCM |



**UNCONSOLIDATED / UNDRAINED COMPRESSIVE STRENGTH
ASTM D 2850**

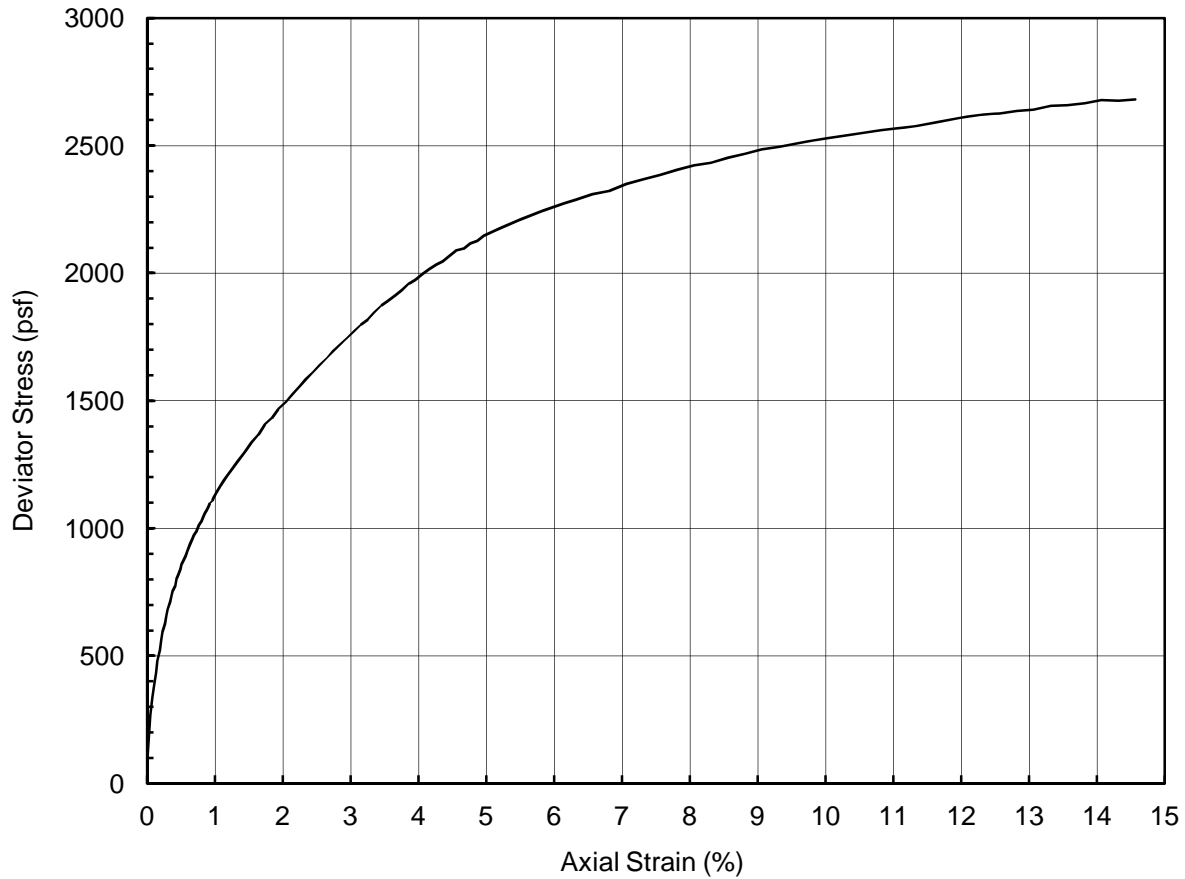

| | | | | | | | | | | | | | | | |
|----------------------|----|----|----|----|-----|------|----|--------------------------|--|--|--|--|--|--|--|
| Specimen Description | | | | | | | | Reddish Gray Clayey Sand | | | | | | | |
| LL | 43 | PI | 28 | LI | 0.2 | USCS | CL | | | | | | | | |

| | | | |
|-------------------------------|-------|---------------------------------|------|
| Depth (ft) | 6.0 | Confining Pressure (psf) | 891 |
| Specimen Height (inch) | 4.6 | Strain Rate (%/min) | 1.0 |
| Specimen Diameter (inch) | 2.8 | Peak Deviator Stress (psf) | 2688 |
| Initial Specimen Weight (g) | 926.5 | Axial Strain at Peak Stress (%) | 14.8 |
| Moist Unit Weight (pcf) | 122.1 | | |
| Initial Water Content (%) | 20 | | |
| Initial Dry Unit Weight (pcf) | 101.5 | | |

| | | | |
|----------------|--------------------------------------|------|--|
| Project Title | Luminant - Big Brown Slope Stability | | |
| Project Number | 123-94128 | | |
| Sample Type | Shelby Tube | | |
| Sample ID | BH-5 | TO-3 | |
| Comments | Sample L/D ratio < 2 | | |

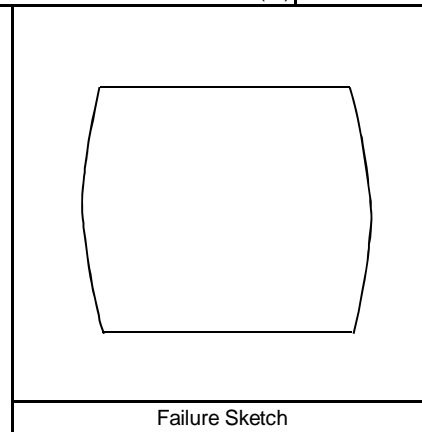

| | |
|--------------|----------|
| Performed by | PN |
| Date | 7-Nov-12 |
| Check | HR |
| Review | PCM |

**UNCONSOLIDATED / UNDRAINED COMPRESSIVE STRENGTH
ASTM D 2850**

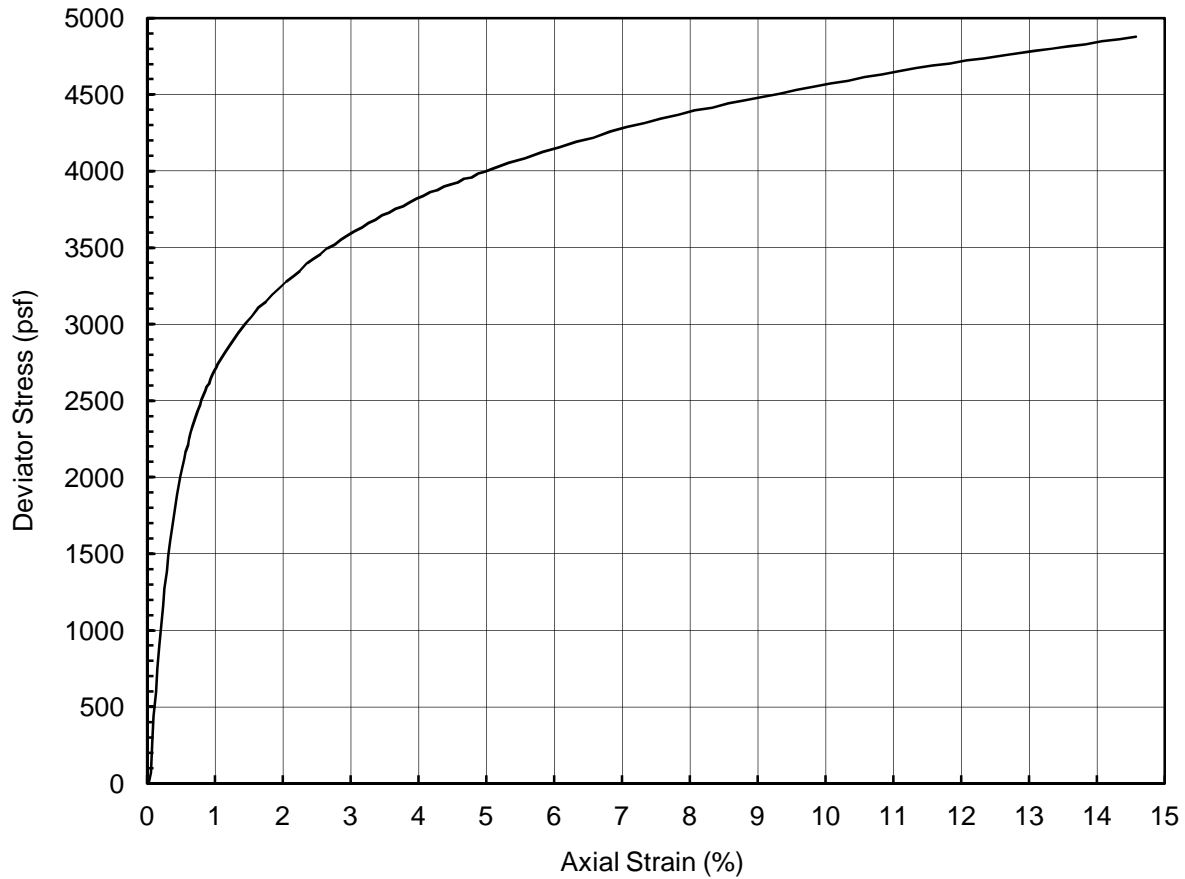

| | | | | | | | |
|----------------------|----|-------------------|----|----|-----|------|----|
| Specimen Description | | Reddish Gray Clay | | | | | |
| LL | 60 | PI | 46 | LI | 0.1 | USCS | CH |

| | | | |
|-------------------------------|--------|---------------------------------|------|
| Depth (ft) | 23.0 | Confining Pressure (psf) | 2879 |
| Specimen Height (inch) | 6.0 | Strain Rate (%/min) | 1.0 |
| Specimen Diameter (inch) | 2.8 | Peak Deviator Stress (psf) | 4887 |
| Initial Specimen Weight (g) | 1218.0 | Axial Strain at Peak Stress (%) | 15.0 |
| Moist Unit Weight (pcf) | 131.2 | | |
| Initial Water Content (%) | 20 | | |
| Initial Dry Unit Weight (pcf) | 109.1 | | |

| | |
|----------------|--------------------------------------|
| Project Title | Luminant - Big Brown Slope Stability |
| Project Number | 123-94128 |
| Sample Type | Shelby Tube |
| Sample ID | BH-5 TO-7 |
| Comments | |

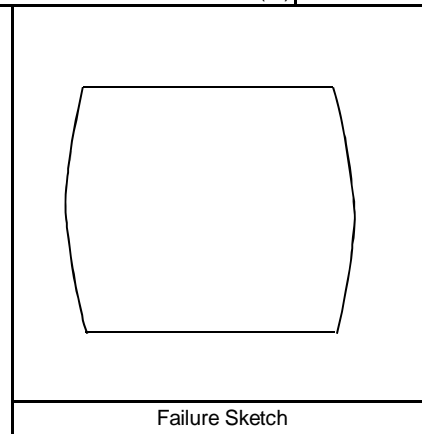

| | |
|--------------|----------|
| Performed by | PN |
| Date | 8-Nov-12 |
| Check | HR |
| Review | PCM |

**UNCONSOLIDATED / UNDRAINED COMPRESSIVE STRENGTH
ASTM D 2850**

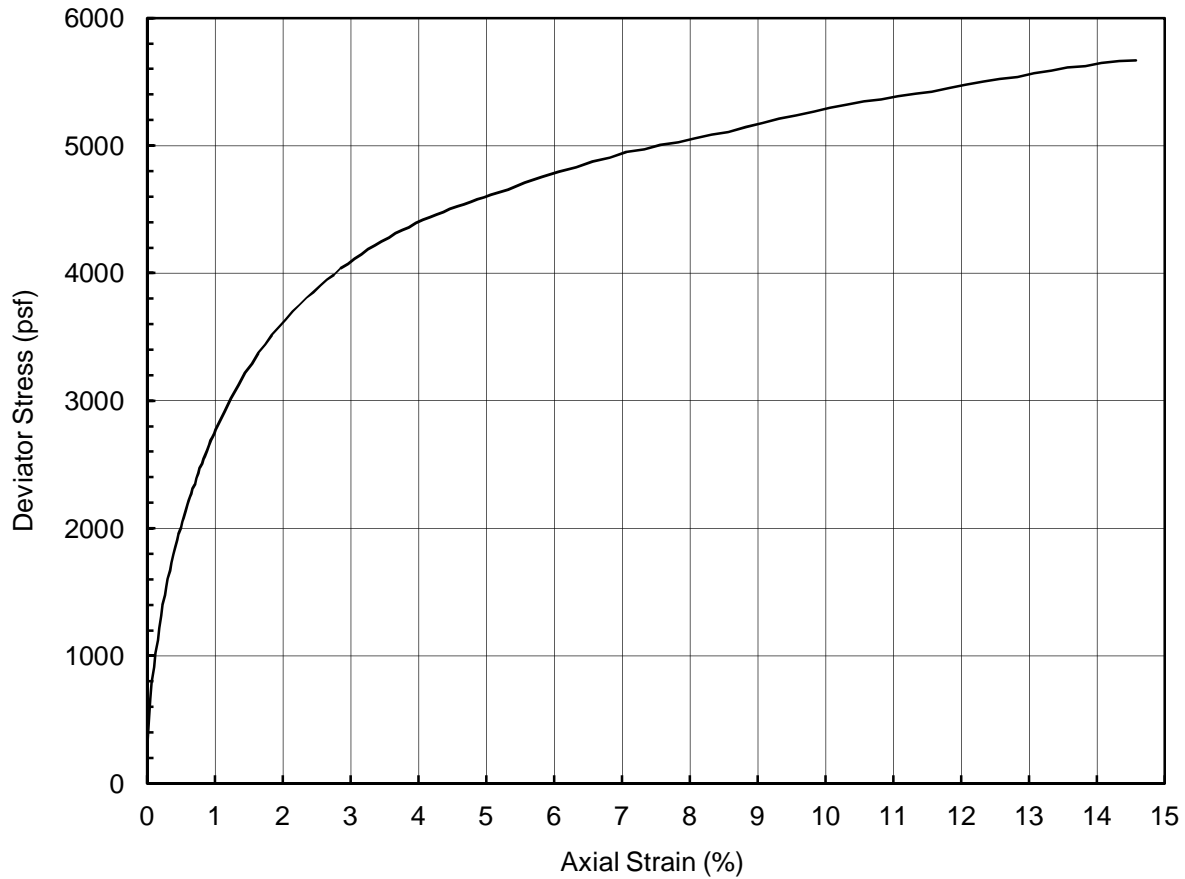

| | | | | | | | |
|----------------------|----|----------------------|----|----|-----|------|----|
| Specimen Description | | Light Red Sandy Clay | | | | | |
| LL | 49 | PI | 33 | LI | 0.0 | USCS | CL |

| | | | |
|-------------------------------|--------|---------------------------------|------|
| Depth (ft) | 13.0 | Confining Pressure (psf) | 1752 |
| Specimen Height (inch) | 5.7 | Strain Rate (%/min) | 1.0 |
| Specimen Diameter (inch) | 2.8 | Peak Deviator Stress (psf) | 5685 |
| Initial Specimen Weight (g) | 1150.2 | Axial Strain at Peak Stress (%) | 14.8 |
| Moist Unit Weight (pcf) | 125.3 | | |
| Initial Water Content (%) | 17 | | |
| Initial Dry Unit Weight (pcf) | 107.5 | | |

| | |
|----------------|--------------------------------------|
| Project Title | Luminant - Big Brown Slope Stability |
| Project Number | 123-94128 |
| Sample Type | Shelby Tube |
| Sample ID | BH-6 TO-5 |
| Comments | |

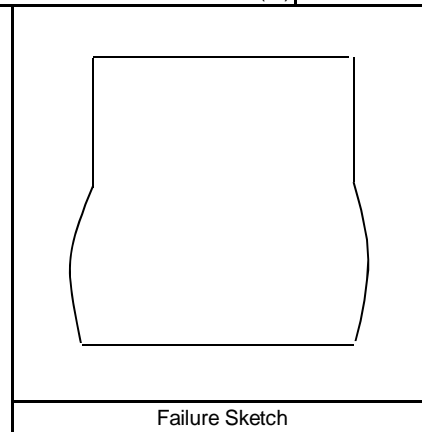

| | |
|--------------|----------|
| Performed by | PN |
| Date | 8-Nov-12 |
| Check | HR |
| Review | PCM |

**UNCONSOLIDATED / UNDRAINED COMPRESSIVE STRENGTH
ASTM D 2850**

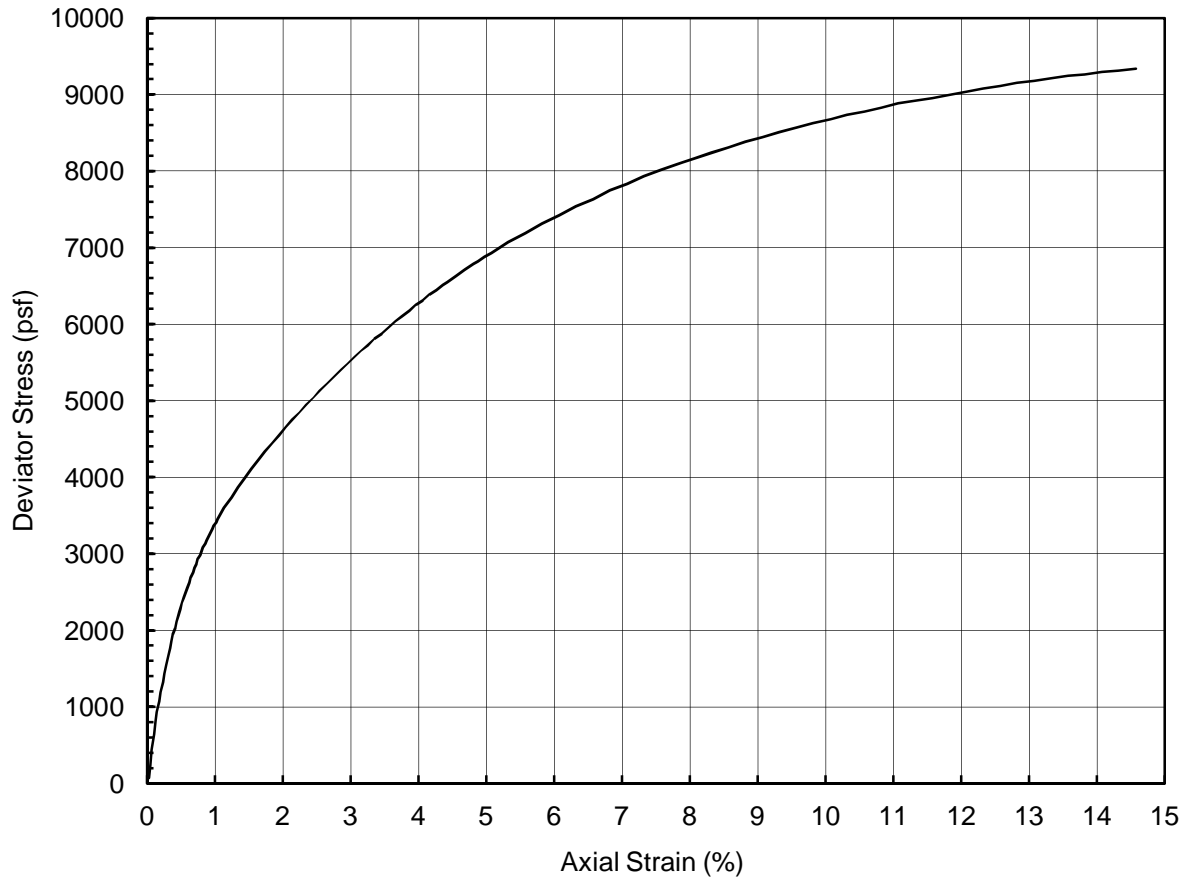

| | | | | | | | |
|----------------------|----|-----------------------|----|----|-----|------|----|
| Specimen Description | | Light Gray Sandy Clay | | | | | |
| LL | 44 | PI | 30 | LI | 0.1 | USCS | CL |

| | | | |
|-------------------------------|--------|---------------------------------|------|
| Depth (ft) | 33.0 | Confining Pressure (psf) | 3304 |
| Specimen Height (inch) | 6.0 | Strain Rate (%/min) | 1.0 |
| Specimen Diameter (inch) | 2.9 | Peak Deviator Stress (psf) | 9360 |
| Initial Specimen Weight (g) | 1270.9 | Axial Strain at Peak Stress (%) | 15.0 |
| Moist Unit Weight (pcf) | 127.4 | | |
| Initial Water Content (%) | 18 | | |
| Initial Dry Unit Weight (pcf) | 107.9 | | |

| | | |
|----------------|--------------------------------------|------|
| Project Title | Luminant - Big Brown Slope Stability | |
| Project Number | 123-94128 | |
| Sample Type | Shelby Tube | |
| Sample ID | BH-6 | TO-9 |
| Comments | | |

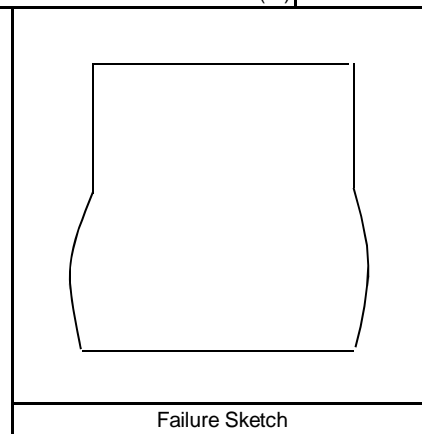

| | |
|--------------|----------|
| Performed by | PN |
| Date | 9-Nov-12 |
| Check | HR |
| Review | PCM |

ISOTROPICALLY CONSOLIDATED UNDRAINED TRIAXIAL TEST (ICU)

Isotropically Consolidated Undrained Triaxial Test (ICU)

Project Title: Big Brown Plant, Pond Stability
Boring Number: BH-1

Project Number: 123-94128
Specimen Name: TO-8

Date: 11-Nov-12
Depth (ft): 28.0

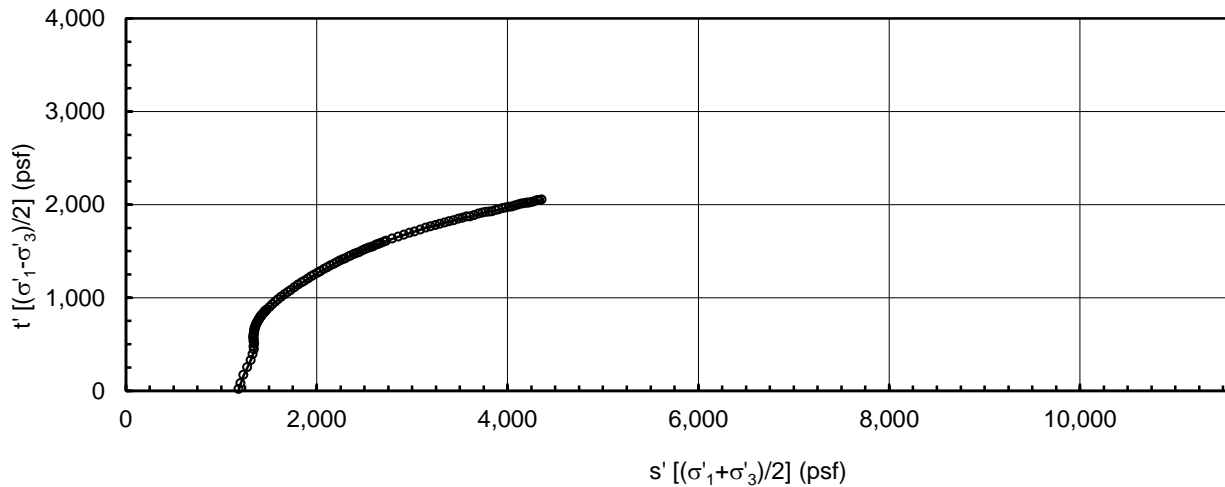
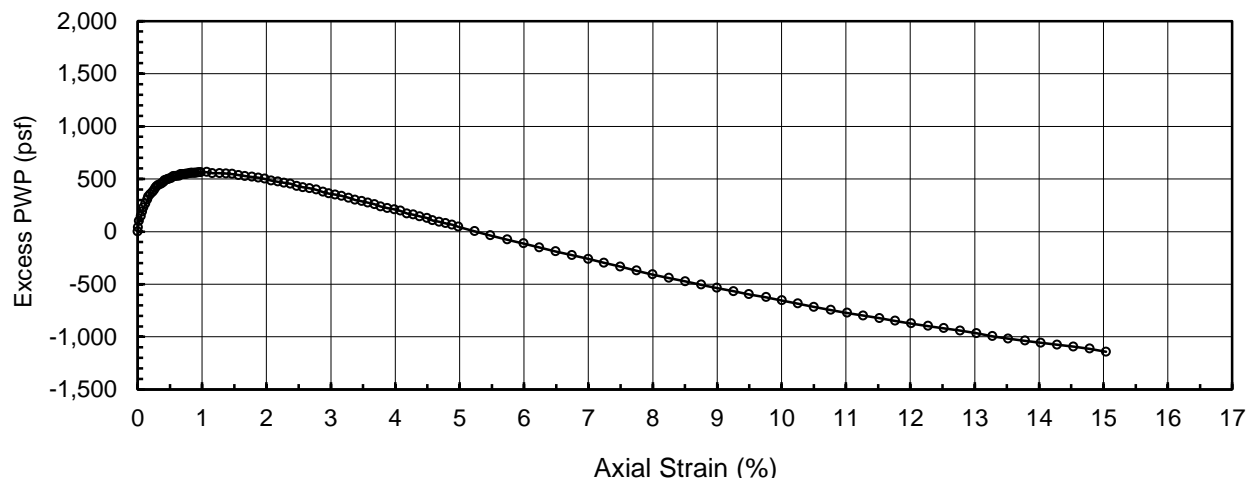
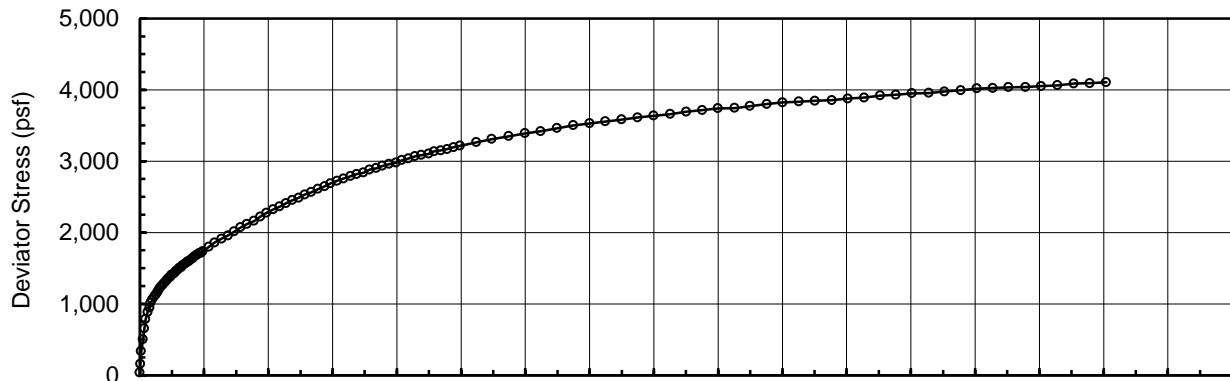

Specimen Description: Dark Gray Sandy CLAY

| | | | |
|--|--------|---|--------|
| Initial Specimen Diameter (inch) = | 2.84 | Initial Specimen Height (inch) = | 5.95 |
| Initial Water Content (%) = | 15.4 | Water Content at End of Test (%) = | 18.4 |
| Initial Moist Unit Weight (pcf) = | 127.6 | B-value = | 0.98 |
| Back Pressure (BP, psf) = | 4320.0 | Consolidation Stress (σ'_3 , psf) = | 1165.6 |
| Initial Lateral Stress (σ'_3 , psf) = | 1165.6 | Consolidation t_{50} (min) = | 10 |
| Initial Deviator Stress ($\sigma_1 - \sigma_3$, psf) = | 36.4 | Rebound Stress (σ'_3 , psf) = | NA |
| Test Strain Rate (%/hour) = | 1.0 | Rebound t_{50} (min) = | NA |
| LL = | 33 | PI = | 20 |
| USCS | CL | Performed by | SBK |
| Comments: | | Reviewed by | PCM |

Isotropically Consolidated Undrained Triaxial Test (ICU)

Project Title: Big Brown Plant, Pond Stability
Boring Number: BH-1

Project Number: 123-94128
Specimen Name: TO-8

Date: 11-Nov-12
Depth (ft): 28.0

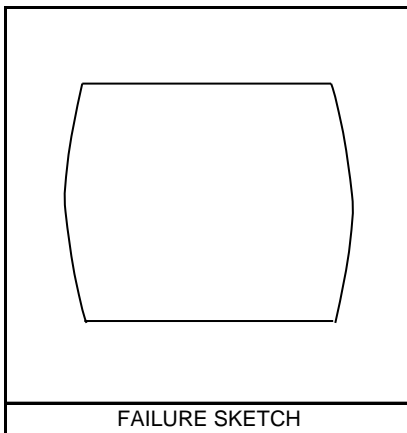
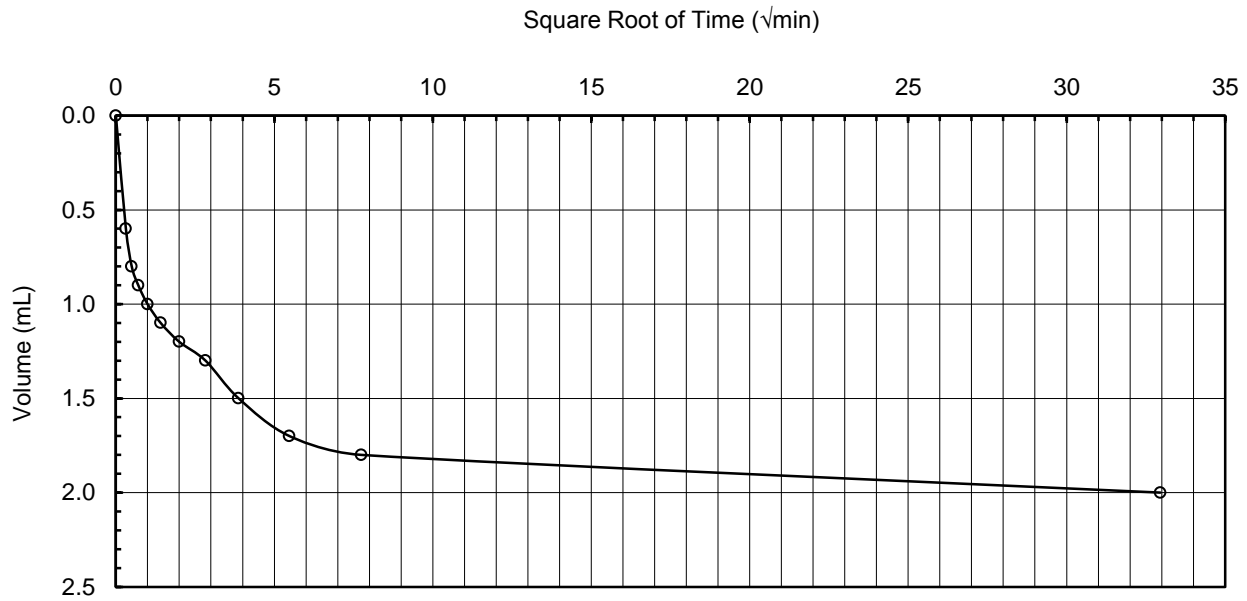

| | | | |
|---|------|---------|----|
| Consolidation Stress (σ'_3 , psf) = | | 1165.6 | |
| Consolidation t_{50} (min) = | | 10 | |
| Consolidation Volume Change (mL) = | | 2.0 | |
| Unloading Stress (psf) = | | NA | |
| Unloading t_{50} (min) = | | NA | |
| Unloading Volume Change (mL) = | | NA | |
| LL = | 33 | PI = | 20 |
| USCS | CL | | |
| Gs = | 2.65 | assumed | |

Performed by SBK
Reviewed by PCM

US EPA ARCHIVE DOCUMENT

Isotropically Consolidated Undrained Triaxial Test (ICU)

Project Title: Big Brown Plant, Pond Stability
Boring Number: BH-1

Project Number: 123-94128
Specimen Name: TO-8

Date: 12-Nov-12
Depth (ft): 28.0

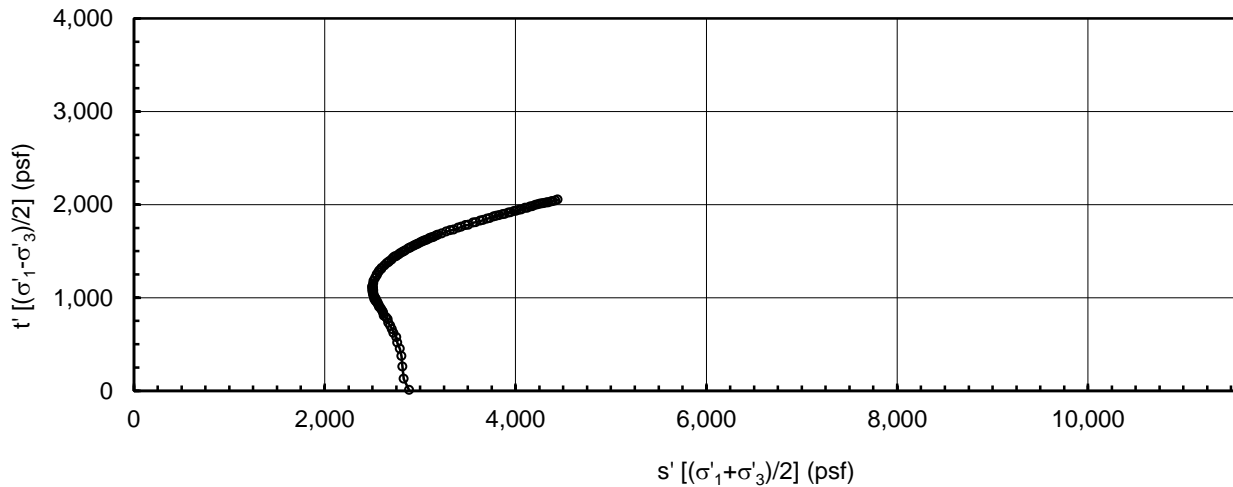
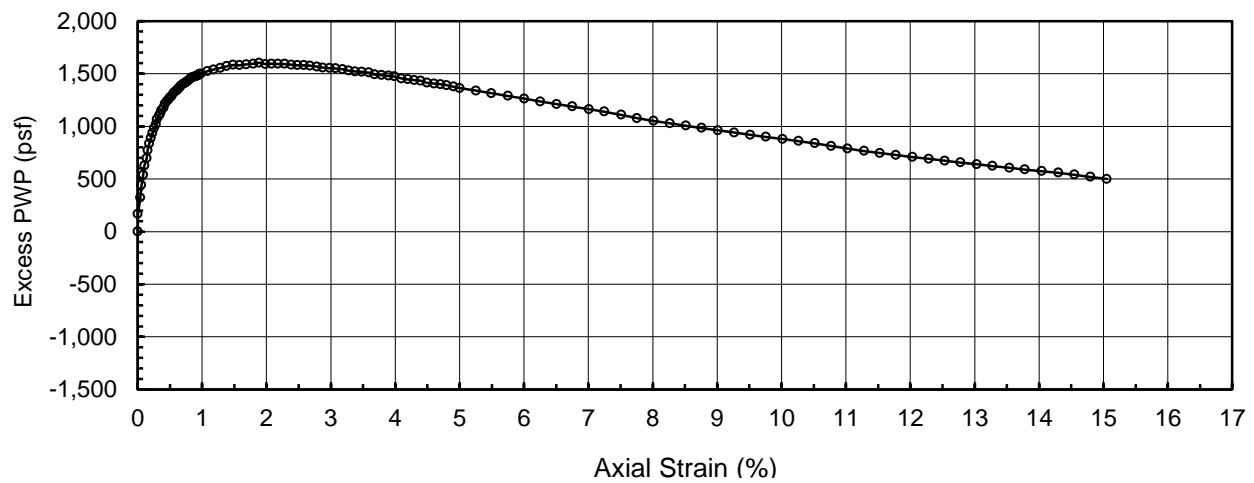
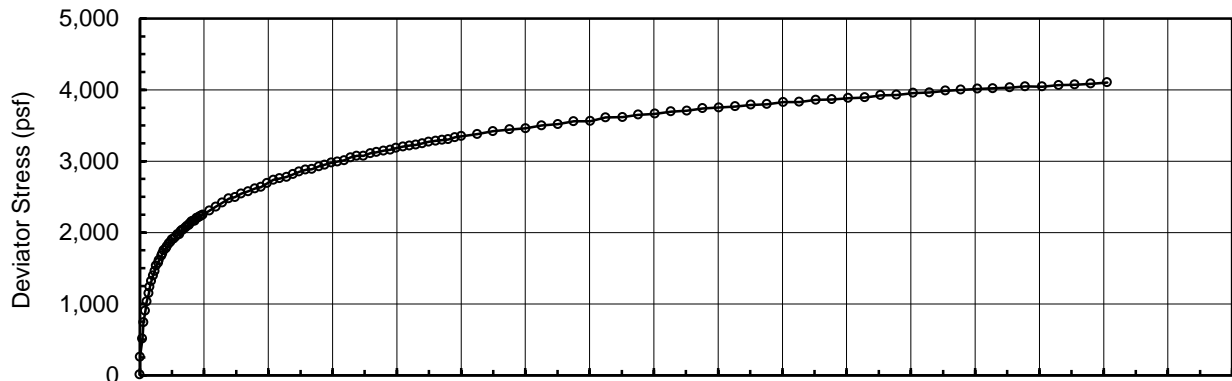

Specimen Description: Dark Gray Sandy CLAY

| | | | | | | | |
|--|----|--------|----|---|----|--------------|-----|
| Initial Specimen Diameter (inch) = | | 2.83 | | Initial Specimen Height (inch) = | | 5.95 | |
| Initial Water Content (%) = | | 16.9 | | Water Content at End of Test (%) = | | 18.0 | |
| Initial Moist Unit Weight (pcf) = | | 128.7 | | B-value = | | 0.99 | |
| Back Pressure (BP, psf) = | | 3600.0 | | Consolidation Stress (σ'_3 , psf) = | | 2879.8 | |
| Initial Lateral Stress (σ'_3 , psf) = | | 2879.8 | | Consolidation t_{50} (min) = | | 3 | |
| Initial Deviator Stress ($\sigma_1 - \sigma_3$, psf) = | | 11.4 | | Rebound Stress (σ'_3 , psf) = | | NA | |
| Test Strain Rate (%/hour) = | | 1.0 | | Rebound t_{50} (min) = | | NA | |
| LL = | 33 | PI = | 20 | USCS | CL | Performed by | SBK |
| Comments: | | | | | | Reviewed by | PCM |

Isotropically Consolidated Undrained Triaxial Test (ICU)

Project Title: Big Brown Plant, Pond Stability
Boring Number: BH-1

Project Number: 123-94128
Specimen Name: TO-8

Date: 12-Nov-12
Depth (ft): 28.0

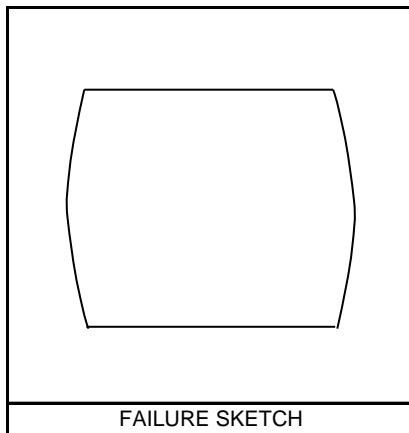
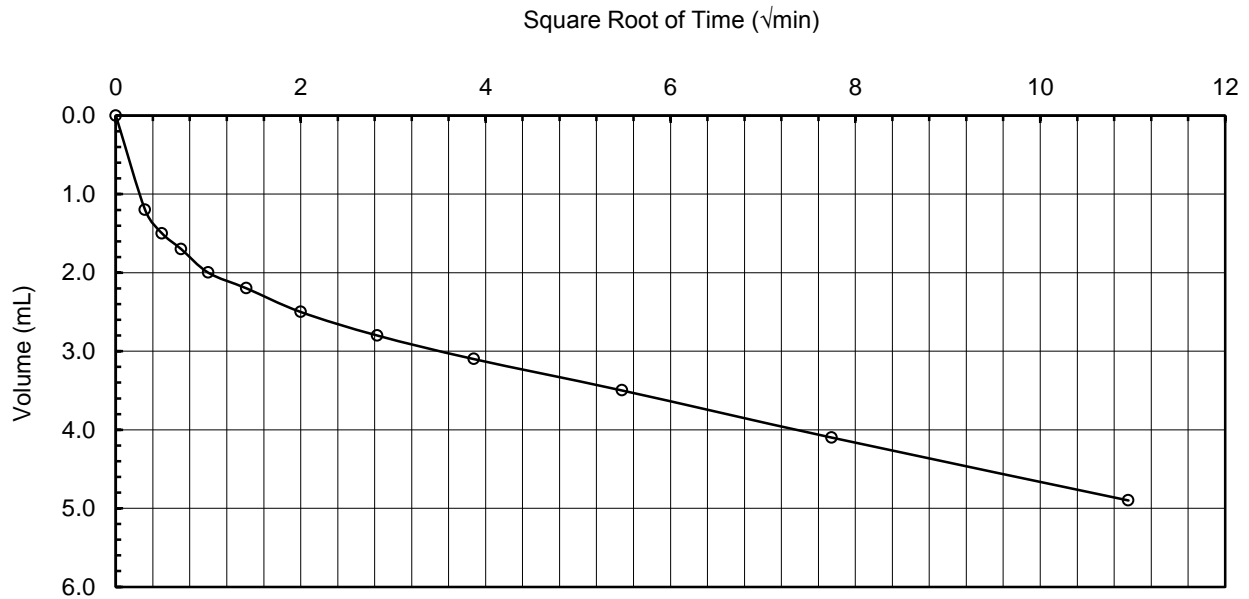

| | | | |
|---|------|---------|----|
| Consolidation Stress (σ'_3 , psf) = | | 2879.8 | |
| Consolidation t_{50} (min) = | | 3 | |
| Consolidation Volume Change (mL) = | | 4.9 | |
| Unloading Stress (psf) = | | NA | |
| Unloading t_{50} (min) = | | NA | |
| Unloading Volume Change (mL) = | | NA | |
| LL = | 33 | PI = | 20 |
| USCS | CL | | |
| Gs = | 2.65 | assumed | |

Performed by SBK
Reviewed by PCM

US EPA ARCHIVE DOCUMENT

Isotropically Consolidated Undrained Triaxial Test (ICU)

Project Title: Big Brown Plant, Pond Stability
Boring Number: BH-1

Project Number: 123-94128
Specimen Name: TO-8

Date: 12-Nov-12
Depth (ft): 28.0

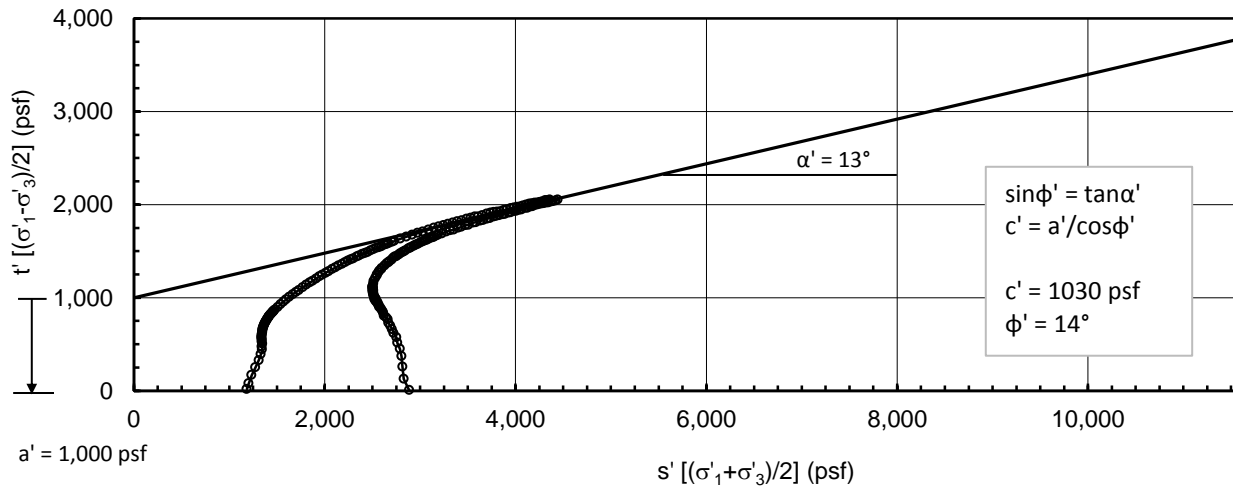
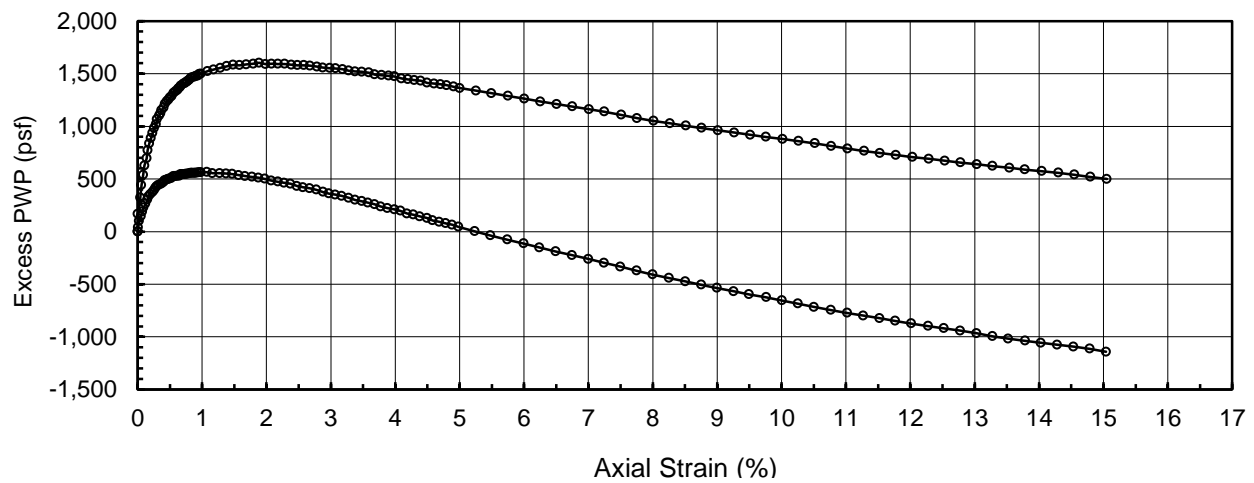
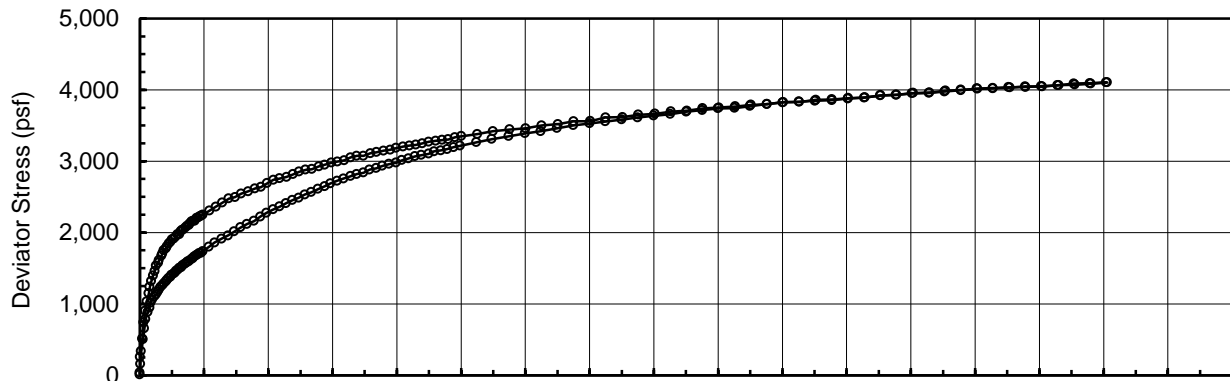

Specimen Description: Dark Gray Sandy CLAY

| | | | |
|--|----|---|------------------|
| Initial Specimen Diameter (inch) = | | Initial Specimen Height (inch) = | |
| Initial Water Content (%) = | | Water Content at End of Test (%) = | |
| Initial Moist Unit Weight (pcf) = | | B-value = | |
| Back Pressure (BP, psf) = | | Consolidation Stress (σ'_3 , psf) = | |
| Initial Lateral Stress (σ'_3 , psf) = | | Consolidation t_{50} (min) = | |
| Initial Deviator Stress ($\sigma_1 - \sigma_3$, psf) = | | Rebound Stress (σ'_3 , psf) = | |
| Test Strain Rate (%/hour) = | | Rebound t_{50} (min) = | |
| LL = | 33 | PI = | 20 |
| USCS | | CL | |
| Comments: | | | Performed by SBK |
| | | | Reviewed by PCM |

Isotropically Consolidated Undrained Triaxial Test (ICU)

Project Title: Big Brown Plant, Pond Stability
Boring Number: BH-1

Project Number: 123-94128
Specimen Name: TO-9

Date: 13-Nov-12
Depth (ft): 33.0

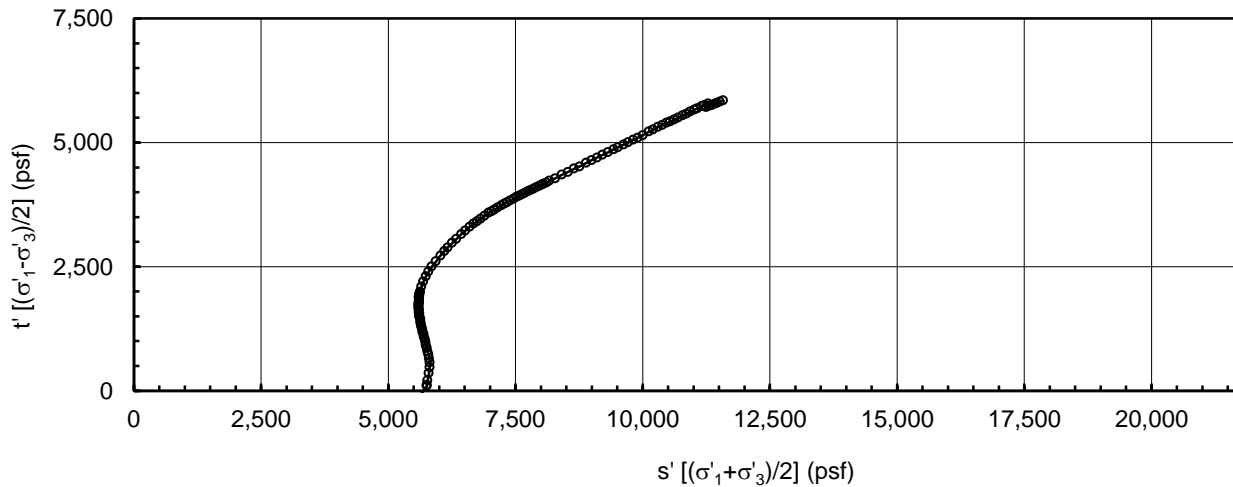
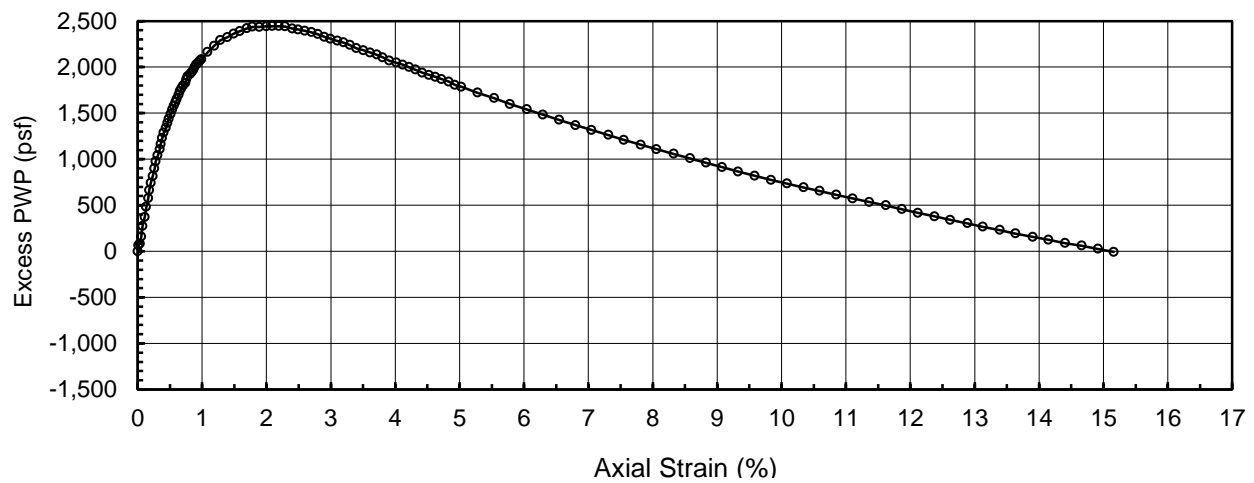
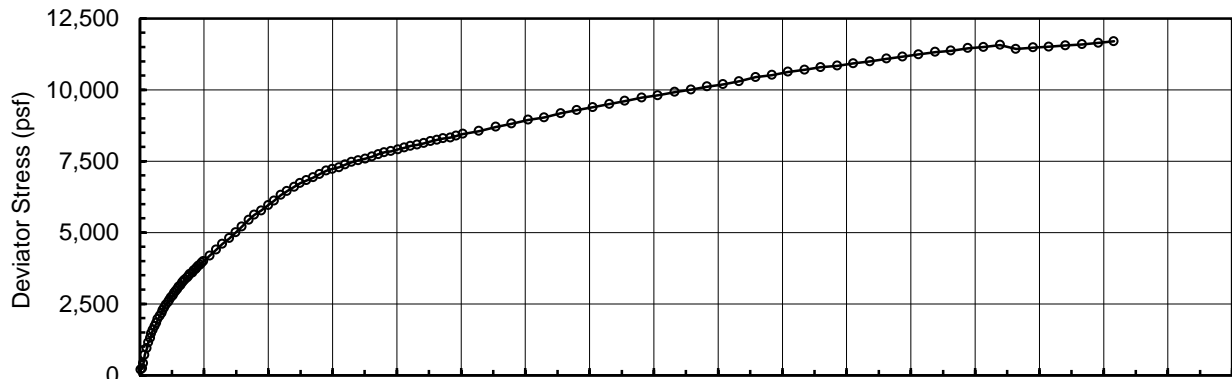

Specimen Description: Light Gray Sandy CLAY (visual classification)

| | | | |
|--|--------|---|-------------------------|
| Initial Specimen Diameter (inch) = | 2.83 | Initial Specimen Height (inch) = | 5.89 |
| Initial Water Content (%) = | 16.1 | Water Content at End of Test (%) = | 17.9 |
| Initial Moist Unit Weight (pcf) = | 127.4 | B-value = | 0.97 |
| Back Pressure (BP, psf) = | 5040.0 | Consolidation Stress (σ'_3 , psf) = | 5717.7 |
| Initial Lateral Stress (σ'_3 , psf) = | 5717.7 | Consolidation t_{50} (min) = | 11 |
| Initial Deviator Stress ($\sigma_1 - \sigma_3$, psf) = | -164.7 | Rebound Stress (σ'_3 , psf) = | NA |
| Test Strain Rate (%/hour) = | 1.0 | Rebound t_{50} (min) = | NA |
| LL = | | PI = | |
| | USCS | | (CL) |
| Comments: | | | Performed by SBK |
| | | | Reviewed by PCM |

Isotropically Consolidated Undrained Triaxial Test (ICU)

Project Title: Big Brown Plant, Pond Stability
Boring Number: BH-1

Project Number: 123-94128
Specimen Name: TO-9

Date: 13-Nov-12
Depth (ft): 33.0

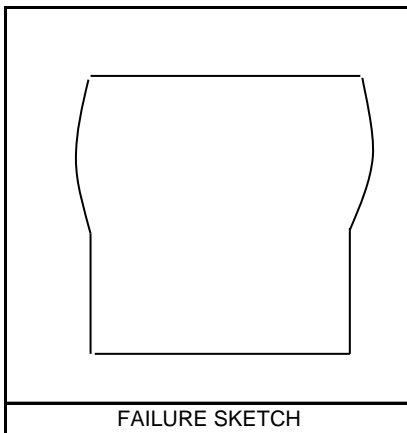
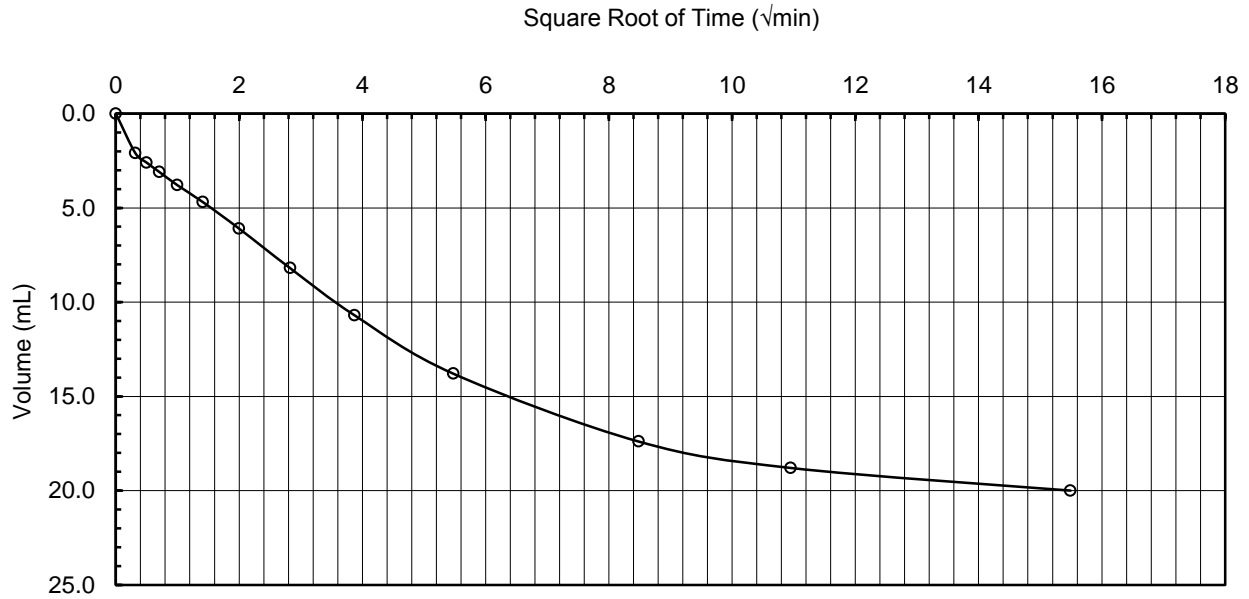

| | | | |
|---|------|---------|--|
| Consolidation Stress (σ'_3 , psf) = | | 5717.7 | |
| Consolidation t_{50} (min) = | | 11 | |
| Consolidation Volume Change (mL) = | | 20.0 | |
| Unloading Stress (psf) = | | NA | |
| Unloading t_{50} (min) = | | NA | |
| Unloading Volume Change (mL) = | | NA | |
| LL = | | PI = | |
| USCS | (CL) | | |
| Gs = | 2.65 | assumed | |

Performed by SBK
Reviewed by PCM

**APPENDIX D
SLOPE STABILITY ANALYSES**

Case 1

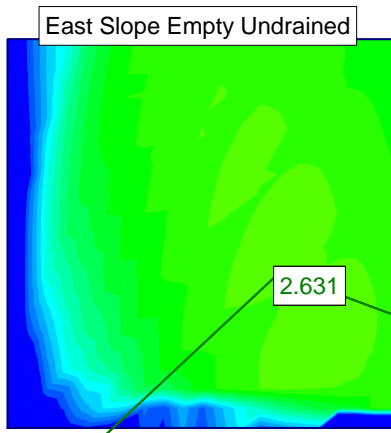
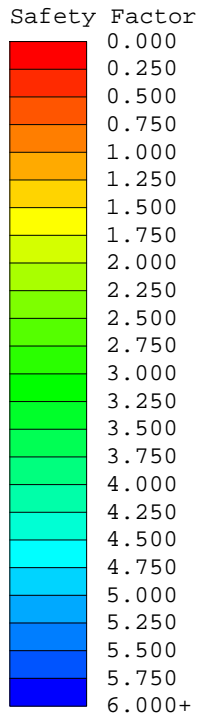

Results
 bishop simplified
 Surface Type: Circular
 Search Method: Grid Search
 Radius Increment: 10
 Composite Surfaces: Disabled
 Reverse Curvature: Create Tension Crack
 Minimum Elevation: Not Defined
 Minimum Depth: Not Defined
 Every available surface
 2.631
 Factor of Safety: 2.631
 Center: -61.281, 375.327
 Radius: 69.391
 Left Slip Surface Endpoint: -112.028, 328.000
 Right Slip Surface Endpoint: 3.752, 351.123

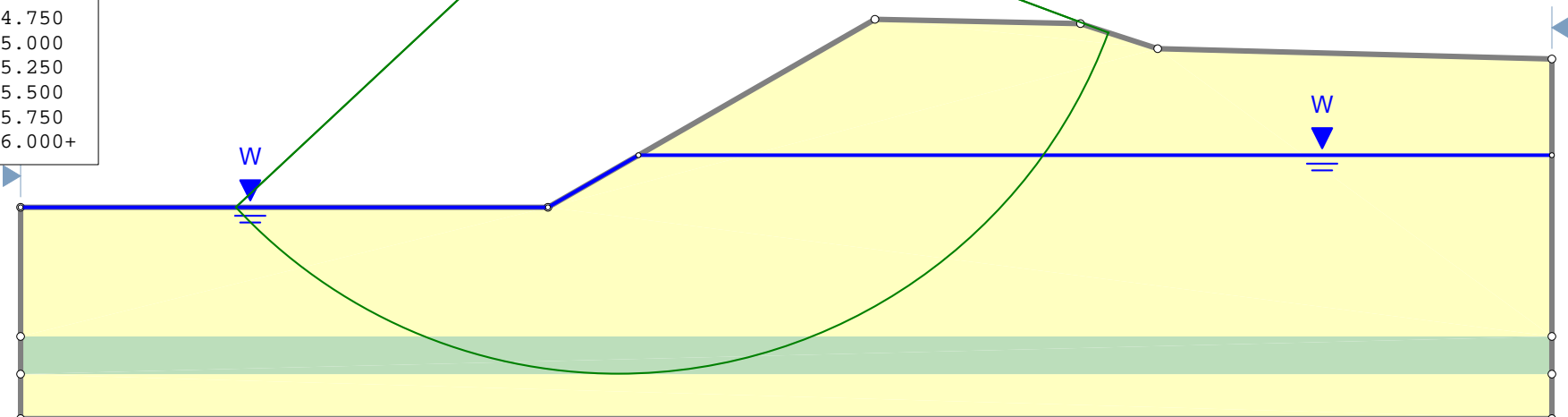

| Material Name | Color | Unit Weight (lbs/ft3) | Sat. Unit Weight (lbs/ft3) | Strength Type | Cohesion (psf) | Phi (deg) | Water Surface | Hu Type |
|-------------------------|-------|-----------------------|----------------------------|---------------|----------------|-----------|---------------|----------|
| Clayey Sand/ Sandy Clay | | 127 | 132 | Mohr-Coulomb | 1500 | 0 | Water Surface | Constant |
| Clean Sand | | 127 | 132 | Mohr-Coulomb | 0 | 29 | Water Surface | Constant |

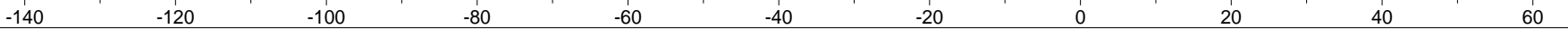

Case 2

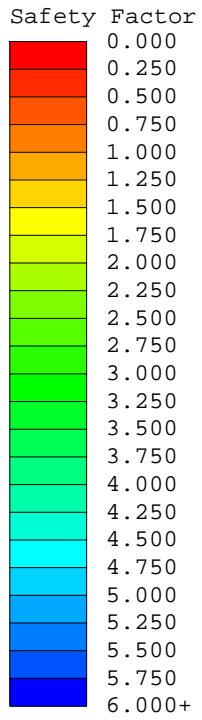

Document
East Slope Empty Drained.sli

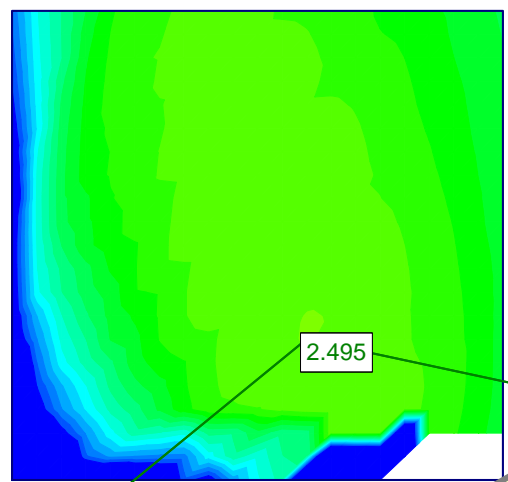

Results
 bishop simplified
 Surface Type: Circular
 Search Method: Grid Search
 Radius Increment: 10
 Composite Surfaces: Disabled
 Reverse Curvature: Create Tension Crack
 Minimum Elevation: Not Defined
 Minimum Depth: Not Defined
 Every available surface
 2.495
 Factor of Safety: 2.495
 Center: -58.985, 364.435
 Radius: 57.569
 Left Slip Surface Endpoint: -103.556, 328.000
 Right Slip Surface Endpoint: -2.689, 352.395

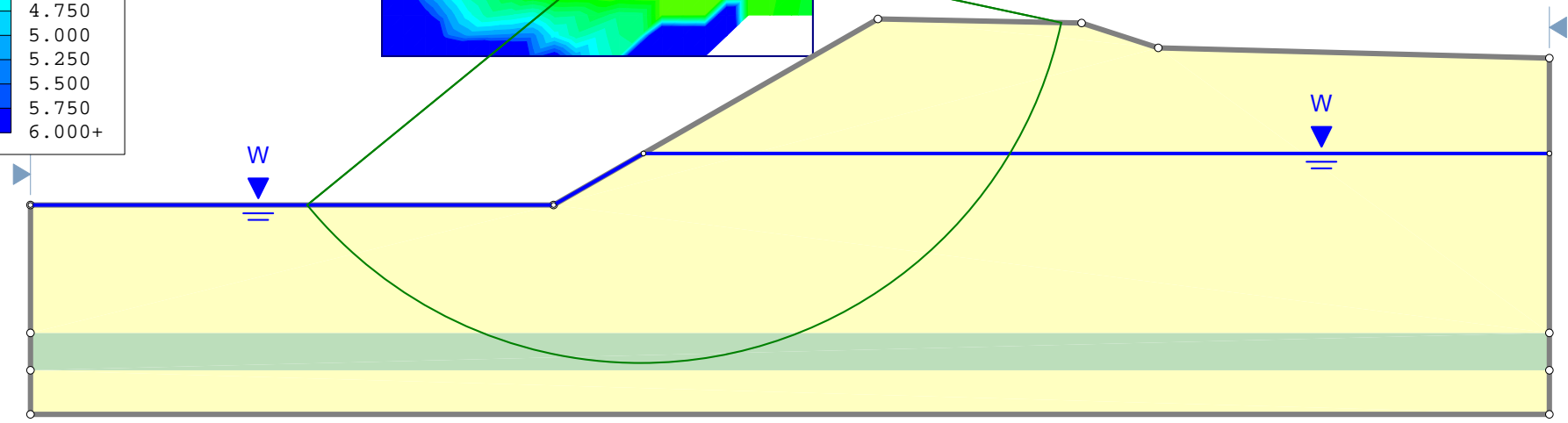

| Material Name | Color | Unit Weight (lbs/ft3) | Sat. Unit Weight (lbs/ft3) | Strength Type | Cohesion (psf) | Phi (deg) | Water Surface | Hu Type |
|-------------------------|-------|-----------------------|----------------------------|---------------|----------------|-----------|---------------|----------|
| Clayey Sand/ Sandy Clay | | 127 | 132 | Mohr-Coulomb | 1000 | 14 | Water Surface | Constant |
| Clean Sand | | 127 | 132 | Mohr-Coulomb | 0 | 29 | Water Surface | Constant |

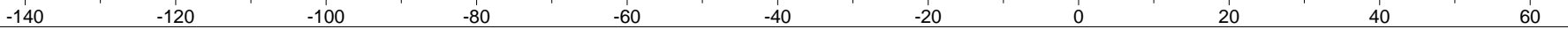

Case 3

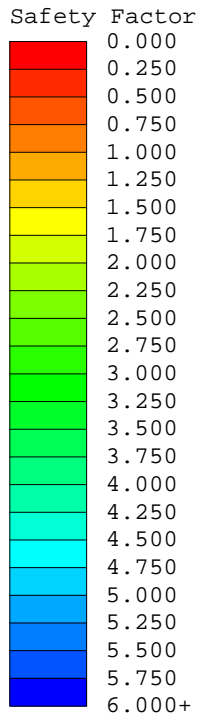

Results
 bishop simplified
 Surface Type: Circular
 Search Method: Grid Search
 Radius Increment: 10
 Composite Surfaces: Disabled
 Reverse Curvature: Create Tension Crack
 Minimum Elevation: Not Defined
 Minimum Depth: Not Defined
 Every available surface
 5.695
 Factor of Safety: 5.695
 Center: -51.463, 362.509
 Radius: 51.200
 Left Slip Surface Endpoint: -89.285, 328.000
 Right Slip Surface Endpoint: -1.278, 352.366
 Left Slope Intercept: -89.285 352.900
 Right Slope Intercept: -1.278 352.366

Document
 East Slope Full Undrained.sli

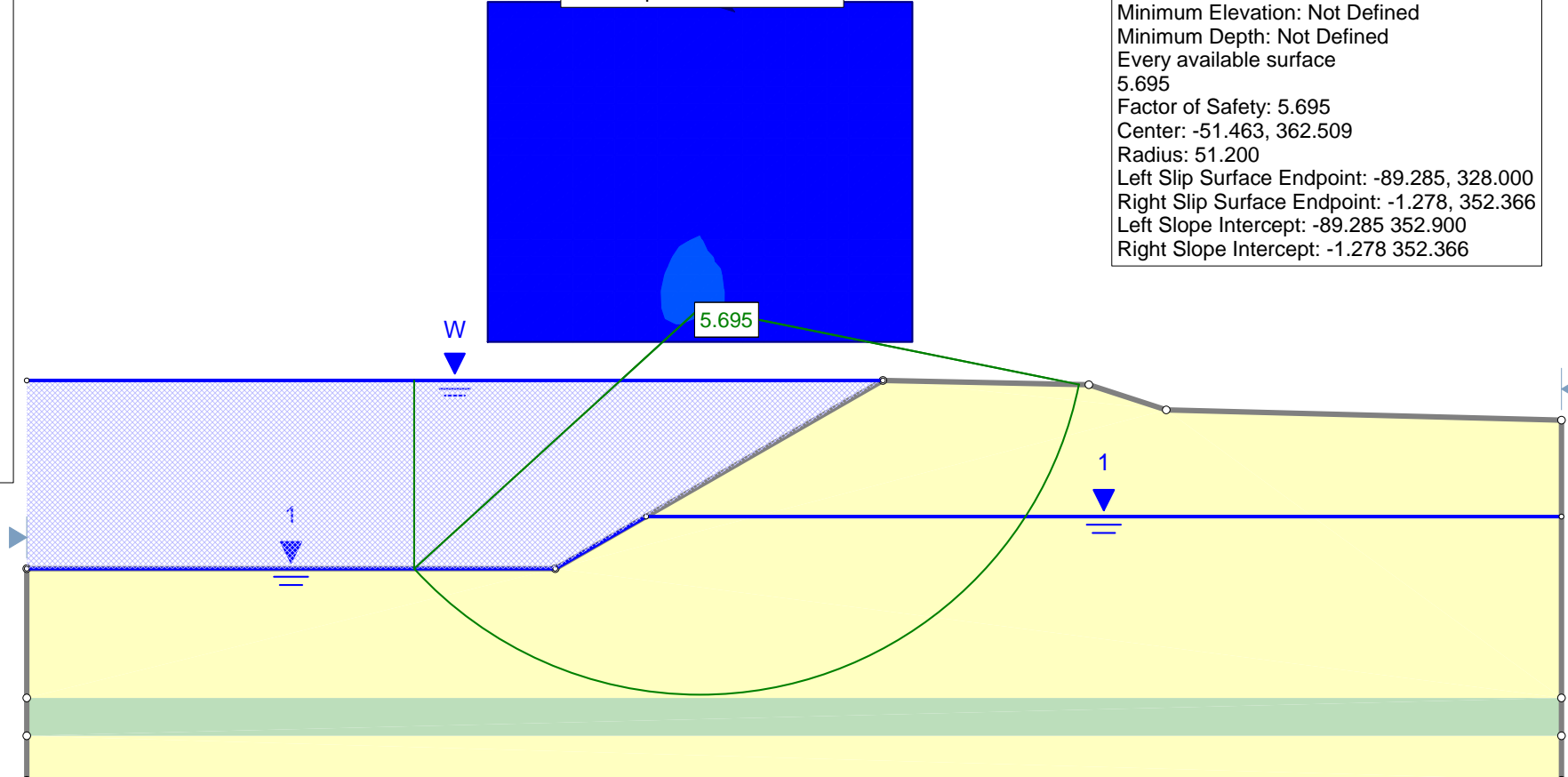

| Material Name | Color | Unit Weight (lbs/ft3) | Sat. Unit Weight (lbs/ft3) | Strength Type | Cohesion (psf) | Phi (deg) | Water Surface | Hu Type |
|-------------------------|-------|-----------------------|----------------------------|---------------|----------------|-----------|--------------------|----------|
| Clayey Sand/ Sandy Clay | | 127 | 132 | Mohr-Coulomb | 1500 | 0 | Piezometric Line 1 | Constant |
| Clean Sand | | 127 | 132 | Mohr-Coulomb | 0 | 29 | Piezometric Line 1 | Constant |

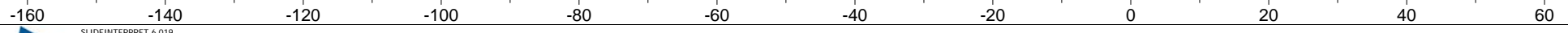

Case 4

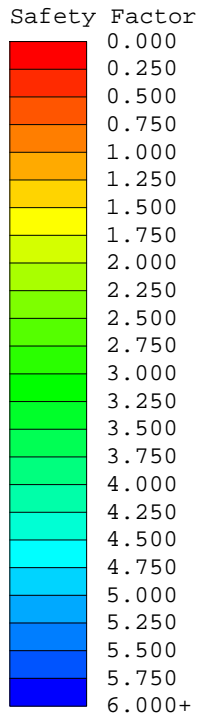

Results
 bishop simplified
 Surface Type: Circular
 Search Method: Grid Search
 Radius Increment: 10
 Composite Surfaces: Disabled
 Reverse Curvature: Create Tension Crack
 Minimum Elevation: Not Defined
 Minimum Depth: Not Defined
 Every available surface
 5.862
 Factor of Safety: 5.862
 Center: -53.612, 365.562
 Radius: 46.698
 Left Slip Surface Endpoint: -81.358, 328.000
 Right Slip Surface Endpoint: -8.772, 352.520
 Left Slope Intercept: -81.358 352.900
 Right Slope Intercept: -8.772 352.520

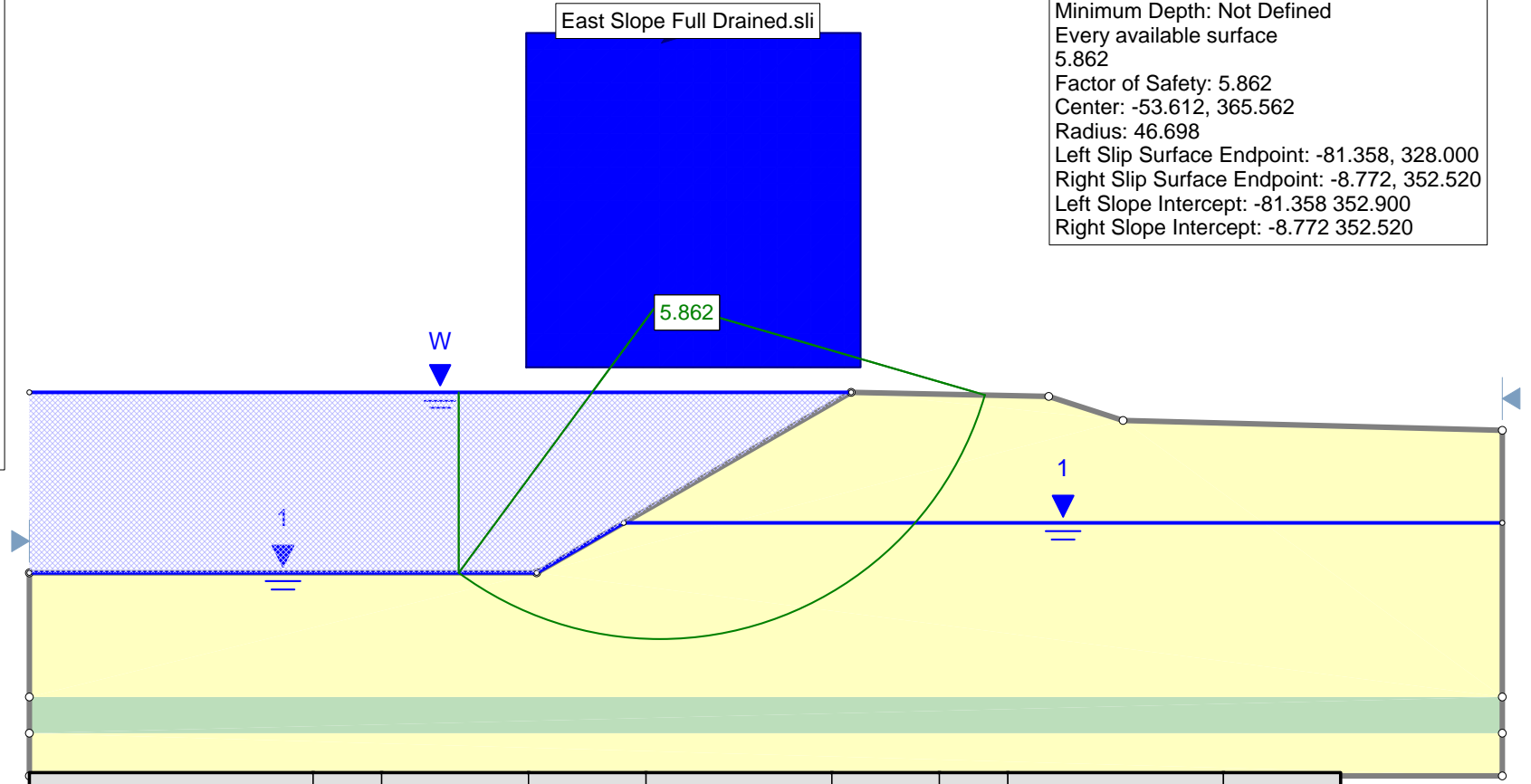

| Material Name | Color | Unit Weight (lbs/ft3) | Sat. Unit Weight (lbs/ft3) | Strength Type | Cohesion (psf) | Phi (deg) | Water Surface | Hu Type |
|-------------------------|-------|-----------------------|----------------------------|---------------|----------------|-----------|--------------------|----------|
| Clayey Sand/ Sandy Clay | | 127 | 132 | Mohr-Coulomb | 1000 | 14 | Piezometric Line 1 | Constant |
| Clean Sand | | 127 | 132 | Mohr-Coulomb | 0 | 29 | Piezometric Line 1 | Constant |

Case 5

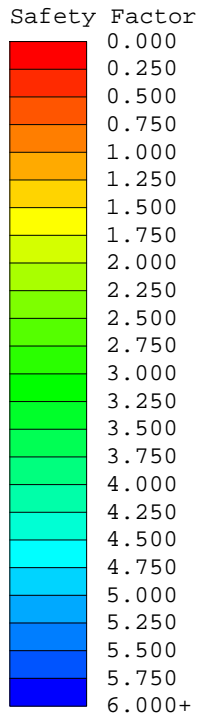

Results
 bishop simplified
 Surface Type: Circular
 Search Method: Grid Search
 Radius Increment: 10
 Composite Surfaces: Disabled
 Reverse Curvature: Create Tension Crack
 Minimum Elevation: Not Defined
 Minimum Depth: Not Defined
 Every available surface
 2.416
 Factor of Safety: 2.416
 Center: -61.865, 375.451
 Radius: 69.296
 Left Slip Surface Endpoint: -112.367, 328.000
 Right Slip Surface Endpoint: 3.099, 351.335

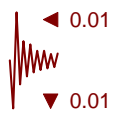

East Slope Empty Drained_seismic load.slim

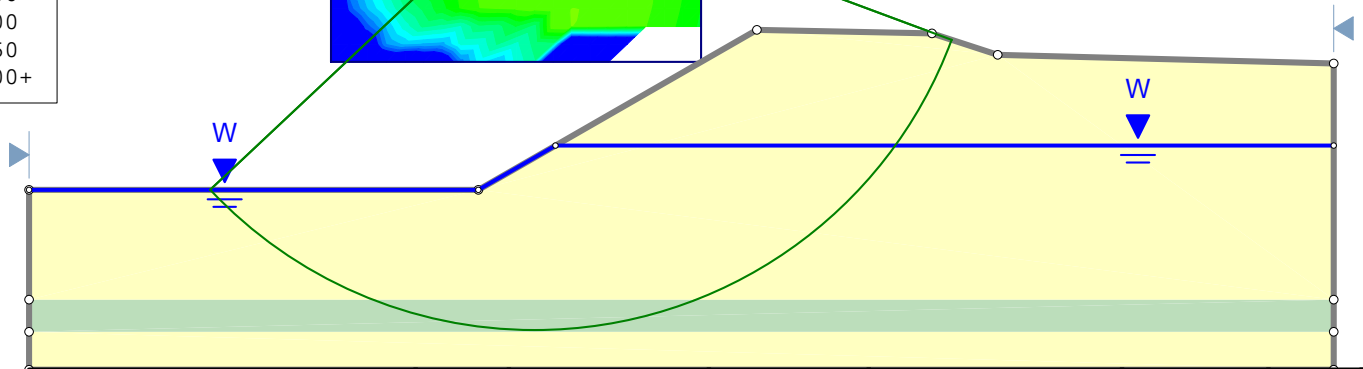
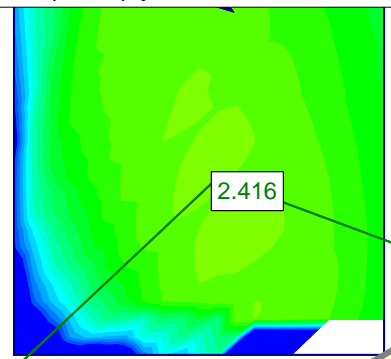

| Material Name | Color | Unit Weight (lbs/ft3) | Sat. Unit Weight (lbs/ft3) | Strength Type | Cohesion (psf) | Phi (deg) | Water Surface | Hu Type |
|-------------------------|-------|-----------------------|----------------------------|---------------|----------------|-----------|---------------|----------|
| Clayey Sand/ Sandy Clay | | 127 | 132 | Mohr-Coulomb | 1000 | 14 | Water Surface | Constant |
| Clean Sand | | 127 | 132 | Mohr-Coulomb | 0 | 29 | Water Surface | Constant |

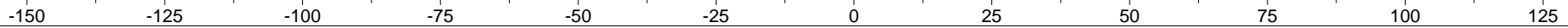

Case 6

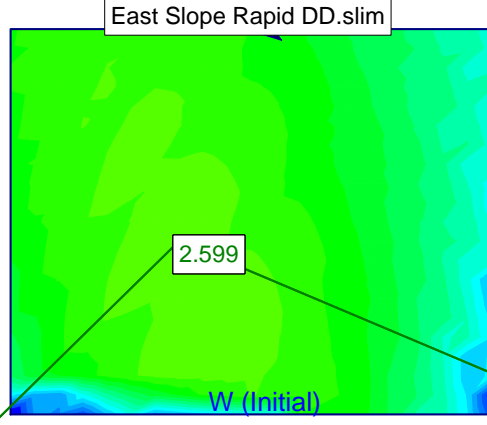
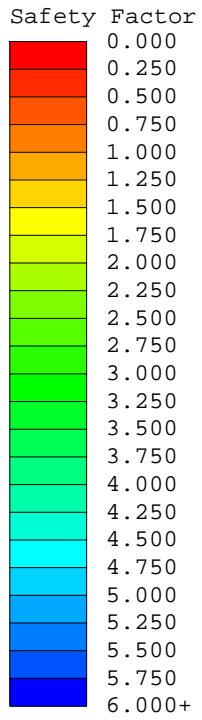

Results
 bishop simplified
 Surface Type: Circular
 Search Method: Grid Search
 Radius Increment: 10
 Composite Surfaces: Disabled
 Reverse Curvature: Create Tension Crack
 Minimum Elevation: Not Defined
 Minimum Depth: Not Defined
 Every available surface
 2.599
 Factor of Safety: 2.599
 Center: -59.893, 378.252
 Radius: 71.745
 Left Slip Surface Endpoint: -111.100, 328.000
 Right Slip Surface Endpoint: 6.197, 350.331

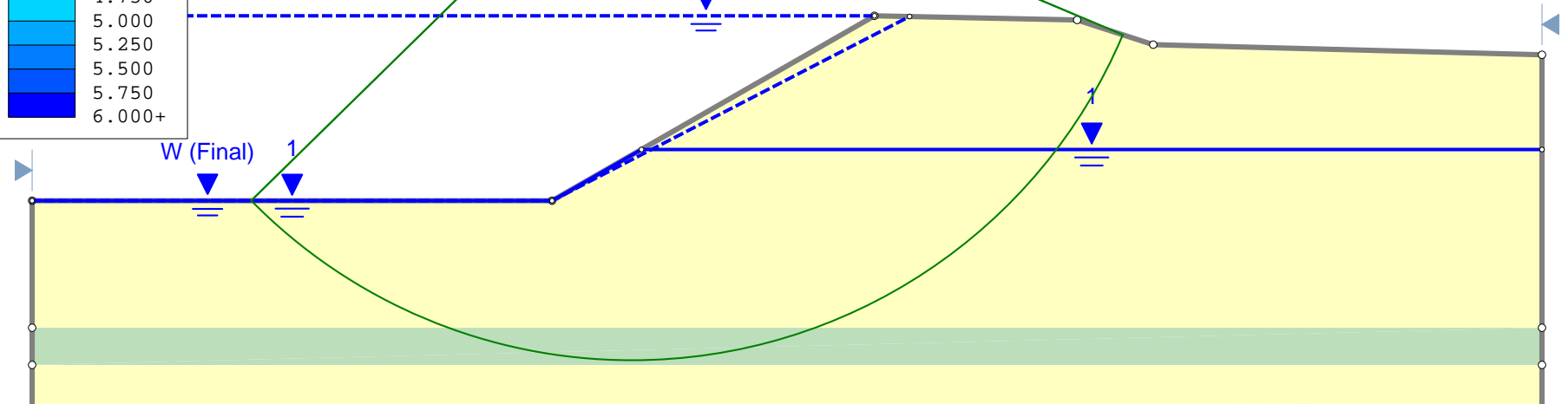

| Material Name | Color | Unit Weight (lbs/ft3) | Sat. Unit Weight (lbs/ft3) | Strength Type | Cohesion (psf) | Phi (deg) | Rapid Drawdown (RD) Undrained Strength | RD Cr (psf) | RD PhiR (deg) | Water Surface | Hu Type |
|-------------------------|-------|-----------------------|----------------------------|---------------|----------------|-----------|--|-------------|---------------|--------------------|----------|
| Clayey Sand/ Sandy Clay | | 127 | 132 | Mohr-Coulomb | 1500 | 0 | Yes | 0 | 0 | Piezometric Line 1 | Constant |
| Clean Sand | | 127 | 132 | Mohr-Coulomb | 0 | 29 | No | | | Piezometric Line 1 | Constant |

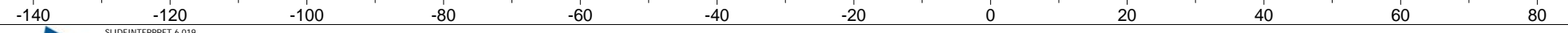

Case 7

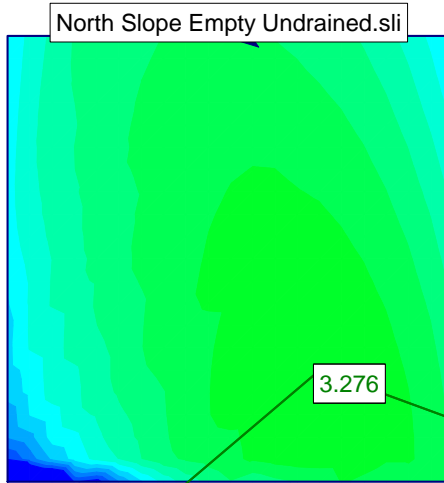
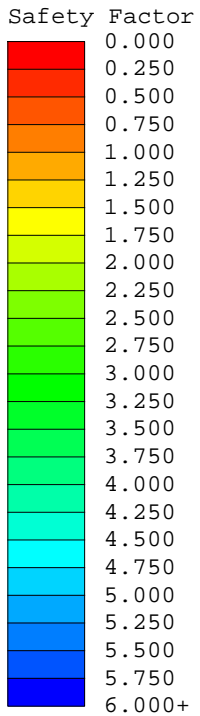

Results
 bishop simplified
 Surface Type: Circular
 Search Method: Grid Search
 Radius Increment: 10
 Composite Surfaces: Disabled
 Reverse Curvature: Create Tension Crack
 Minimum Elevation: Not Defined
 Minimum Depth: Not Defined
 Every available surface
 3.276
 Factor of Safety: 3.276
 Center: 86.346, 366.662
 Radius: 58.920
 Left Slip Surface Endpoint: 41.434, 328.525
 Right Slip Surface Endpoint: 141.675, 346.409

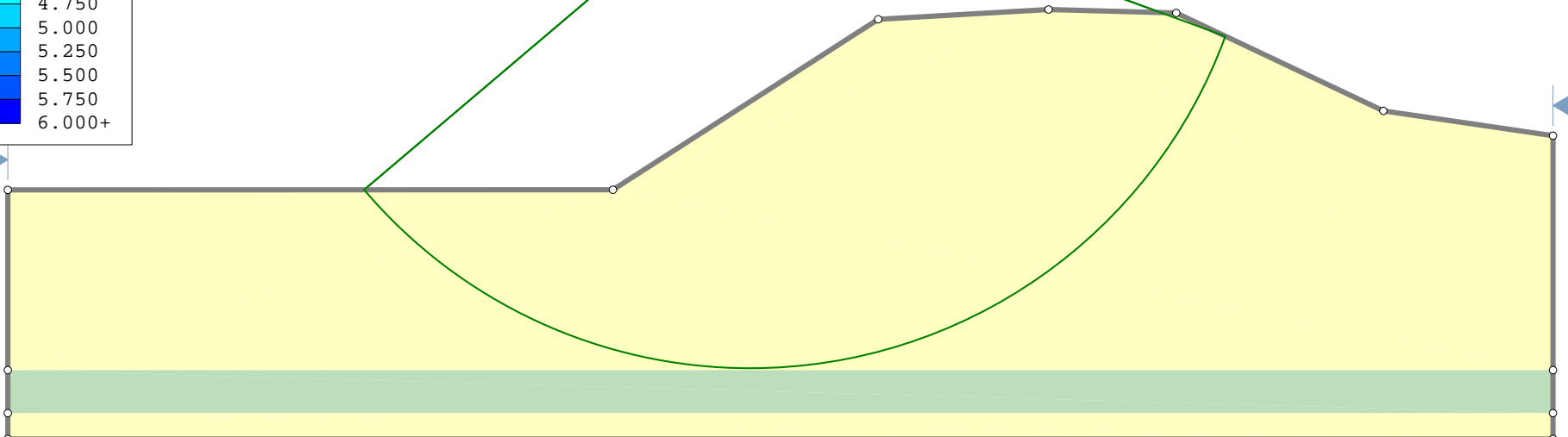

| Material Name | Color | Unit Weight (lbs/ft3) | Strength Type | Cohesion (psf) | Phi (deg) | Water Surface | Ru |
|-------------------------|-------|-----------------------|---------------|----------------|-----------|---------------|----|
| Clayey Sand/ Sandy Clay | | 127 | Mohr-Coulomb | 1500 | 0 | None | 0 |
| Clean Sand | | 127 | Mohr-Coulomb | 0 | 29 | None | 0 |

Case 8

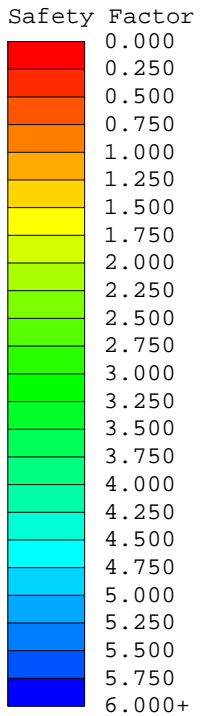

North Slope Empty Drained.sli

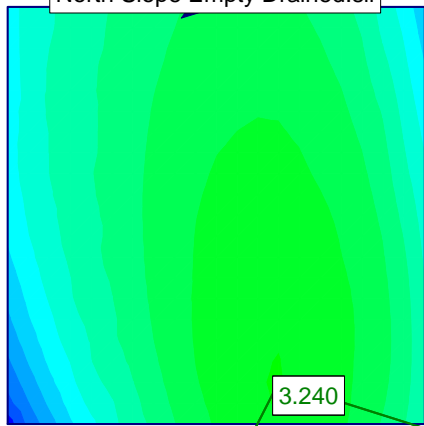

Results
 bishop simplified
 Surface Type: Circular
 Search Method: Grid Search
 Radius Increment: 10
 Composite Surfaces: Disabled
 Reverse Curvature: Create Tension Crack
 Minimum Elevation: Not Defined
 Minimum Depth: Not Defined
 Every available surface
 3.240
 Factor of Safety: 3.240
 Center: 84.109, 359.951
 Radius: 35.290
 Left Slip Surface Endpoint: 68.044, 328.530
 Right Slip Surface Endpoint: 117.765, 349.337

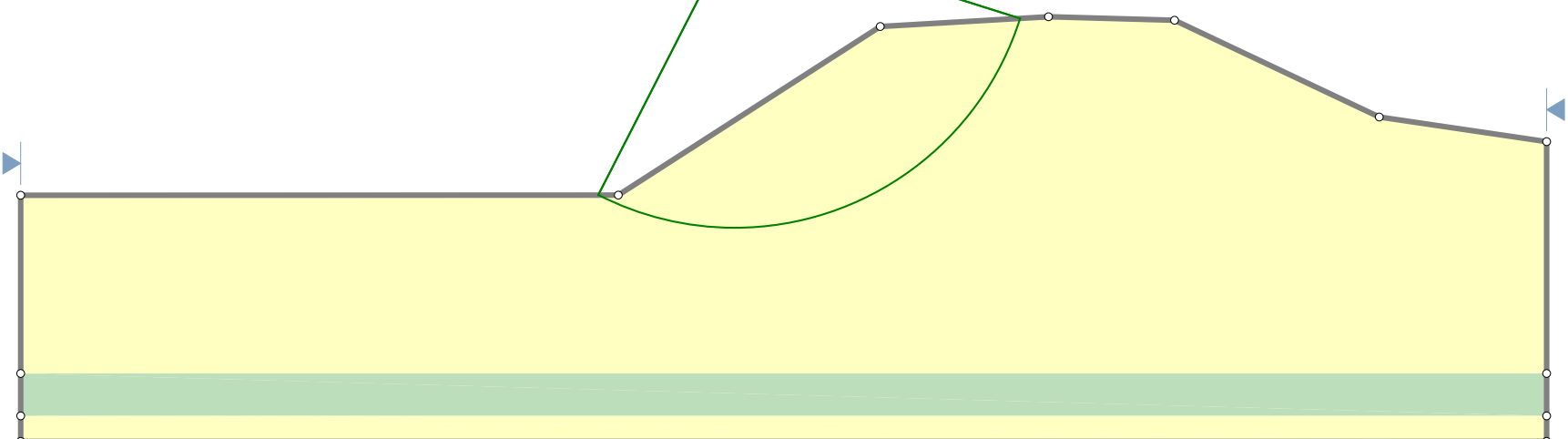

| Material Name | Color | Unit Weight (lbs/ft3) | Strength Type | Cohesion (psf) | Phi (deg) | Water Surface | Ru |
|-------------------------|-------|-----------------------|---------------|----------------|-----------|---------------|----|
| Clayey Sand/ Sandy Clay | | 127 | Mohr-Coulomb | 1000 | 14 | None | 0 |
| Clean Sand | | 127 | Mohr-Coulomb | 0 | 29 | None | 0 |

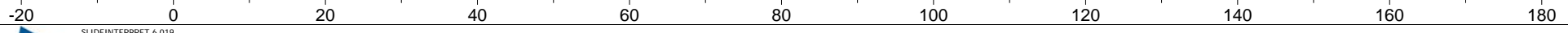

Case 9

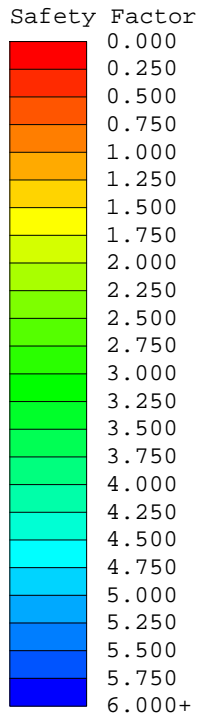

Results
 bishop simplified
 Surface Type: Circular
 Search Method: Grid Search
 Radius Increment: 10
 Composite Surfaces: Disabled
 Reverse Curvature: Create Tension Crack
 Minimum Elevation: Not Defined
 Minimum Depth: Not Defined
 Every available surface
 6.335
 Factor of Safety: 6.335
 Center: 84.109, 366.662
 Radius: 58.504
 Left Slip Surface Endpoint: 39.744, 328.524
 Right Slip Surface Endpoint: 139.383, 347.492
 Left Slope Intercept: 39.744 348.380
 Right Slope Intercept: 139.383 347.492

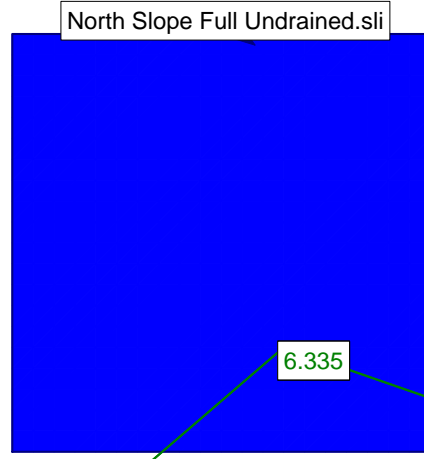

6.335

W

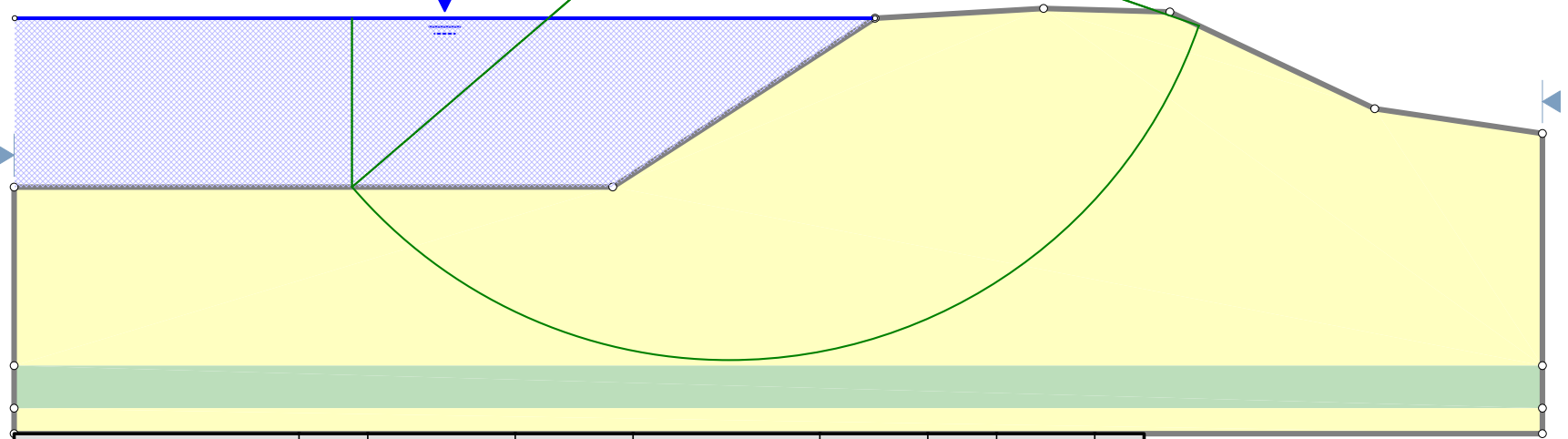

| Material Name | Color | Unit Weight (lbs/ft3) | Sat. Unit Weight (lbs/ft3) | Strength Type | Cohesion (psf) | Phi (deg) | Water Surface | Ru |
|-------------------------|-------|-----------------------|----------------------------|---------------|----------------|-----------|---------------|----|
| Clayey Sand/ Sandy Clay | | 127 | 132 | Mohr-Coulomb | 1500 | 0 | None | 0 |
| Clean Sand | | 127 | 132 | Mohr-Coulomb | 0 | 29 | None | 0 |

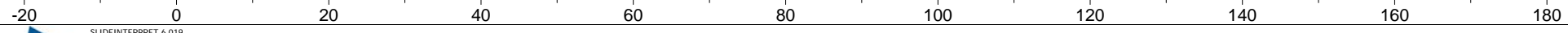

Case 10

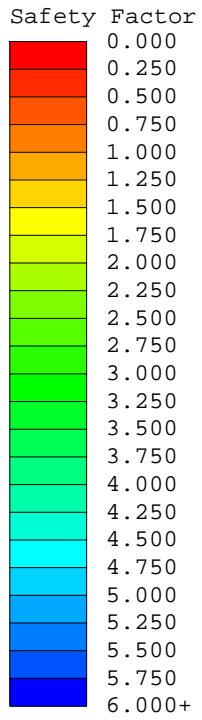

Results
 bishop simplified
 Surface Type: Circular
 Search Method: Grid Search
 Radius Increment: 10
 Composite Surfaces: Disabled
 Reverse Curvature: Create Tension Crack
 Minimum Elevation: Not Defined
 Minimum Depth: Not Defined
 Every available surface
 6.588
 Factor of Safety: 6.588
 Center: 83.388, 367.214
 Radius: 40.785
 Left Slip Surface Endpoint: 70.426, 328.543
 Right Slip Surface Endpoint: 120.113, 349.473
 Left Slope Intercept: 70.426 348.380
 Right Slope Intercept: 120.113 349.473

North Slope Full Drained.sli

6.588

W

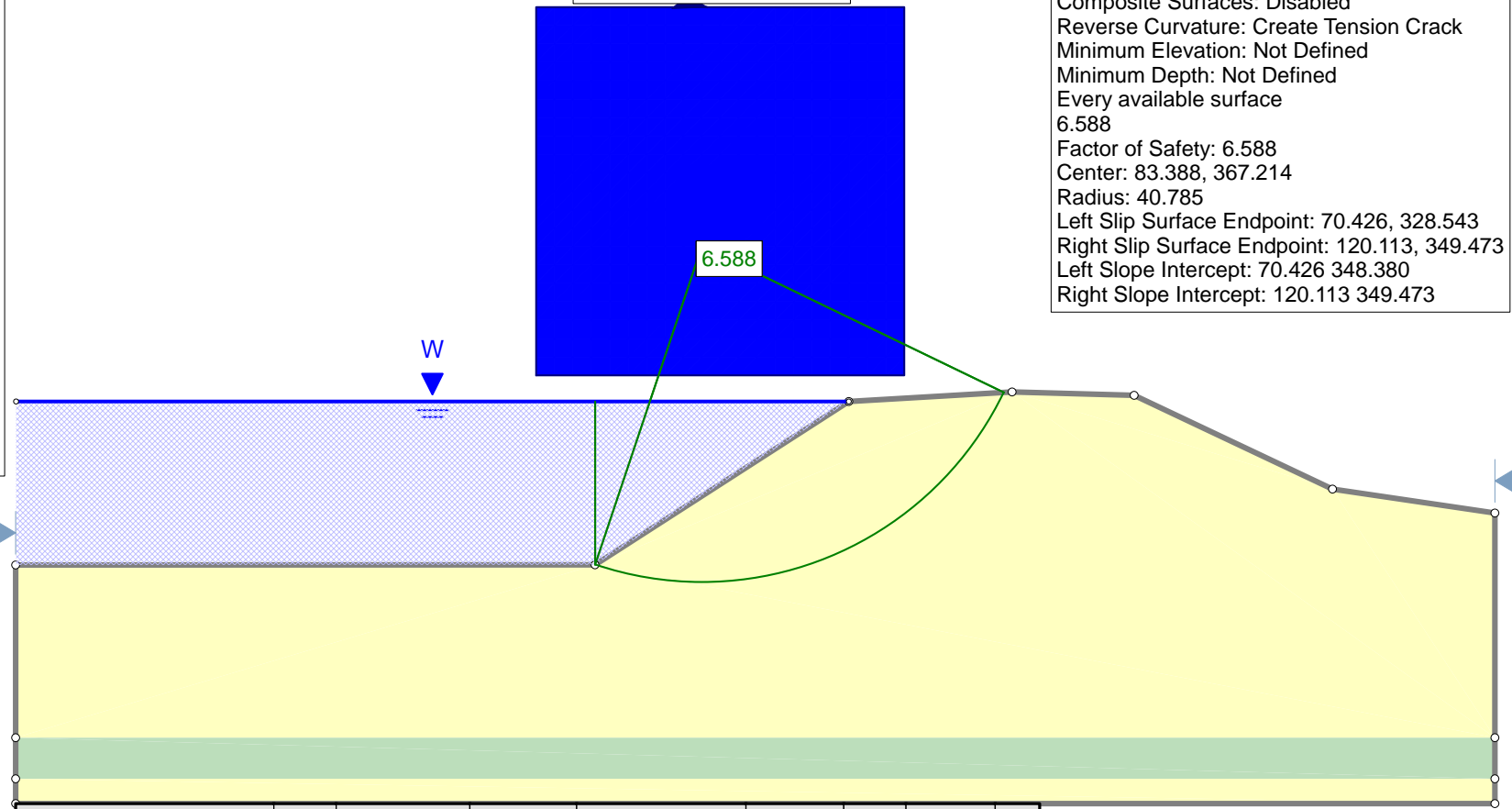

| Material Name | Color | Unit Weight (lbs/ft3) | Sat. Unit Weight (lbs/ft3) | Strength Type | Cohesion (psf) | Phi (deg) | Water Surface | Ru |
|-------------------------|-------|-----------------------|----------------------------|---------------|----------------|-----------|---------------|----|
| Clayey Sand/ Sandy Clay | | 127 | 132 | Mohr-Coulomb | 1000 | 14 | None | 0 |
| Clean Sand | | 127 | 132 | Mohr-Coulomb | 0 | 29 | None | 0 |

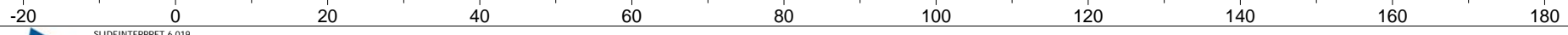

Case 11

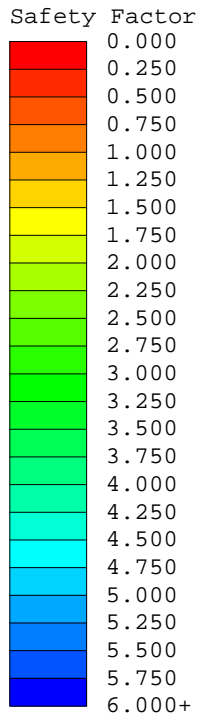

Results
 bishop simplified
 Surface Type: Circular
 Search Method: Grid Search
 Radius Increment: 10
 Composite Surfaces: Disabled
 Reverse Curvature: Create Tension Crack
 Minimum Elevation: Not Defined
 Minimum Depth: Not Defined
 Every available surface
 3.117
 Factor of Safety: 3.117
 Center: 79.635, 366.662
 Radius: 63.197
 Left Slip Surface Endpoint: 29.244, 328.522
 Right Slip Surface Endpoint: 139.792, 347.299

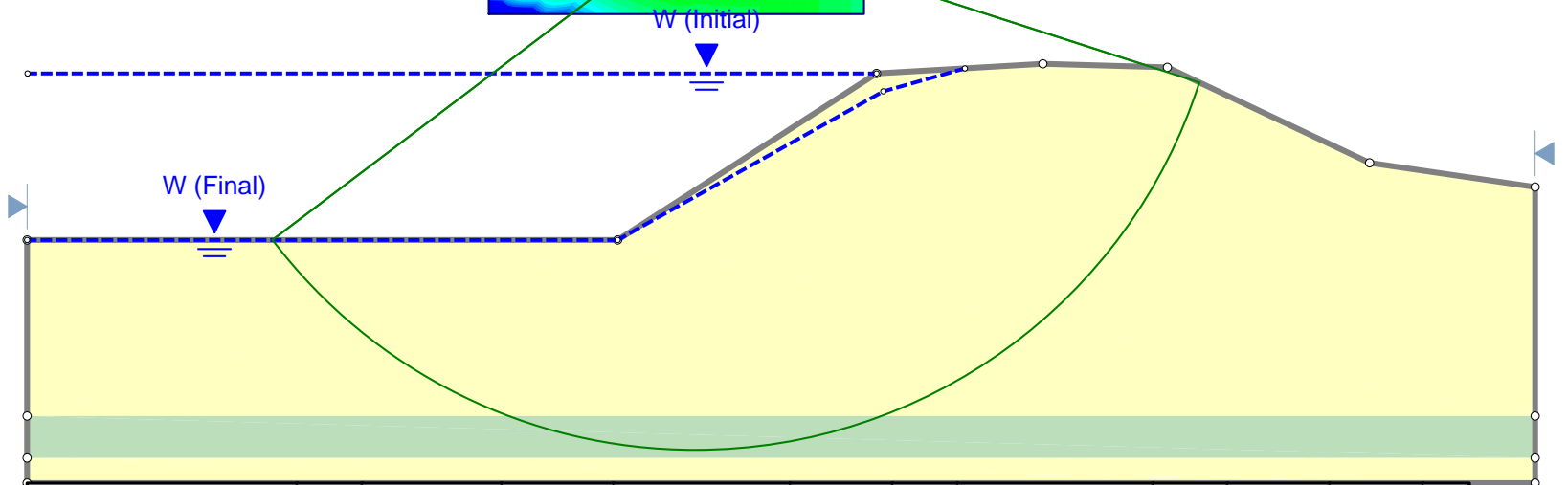
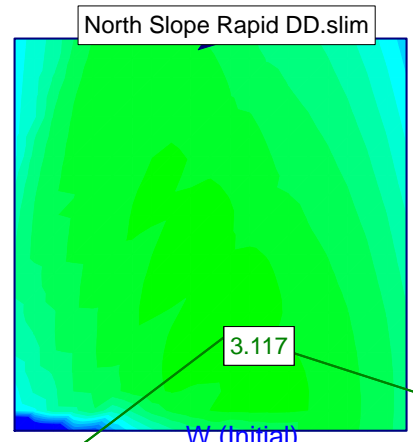

| Material Name | Color | Unit Weight (lbs/ft3) | Sat. Unit Weight (lbs/ft3) | Strength Type | Cohesion (psf) | Phi (deg) | Rapid Drawdown (RD) Undrained Strength | RD Cr (psf) | RD PhiR (deg) | Water Surface | Ru |
|-------------------------|-------|-----------------------|----------------------------|---------------|----------------|-----------|--|-------------|---------------|---------------|----|
| Clayey Sand/ Sandy Clay | | 127 | 132 | Mohr-Coulomb | 1500 | 0 | Yes | 0 | 0 | None | 0 |
| Clean Sand | | 127 | 132 | Mohr-Coulomb | 0 | 29 | No | | | None | 0 |

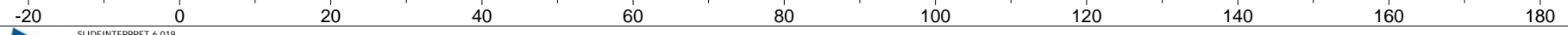

Case 12

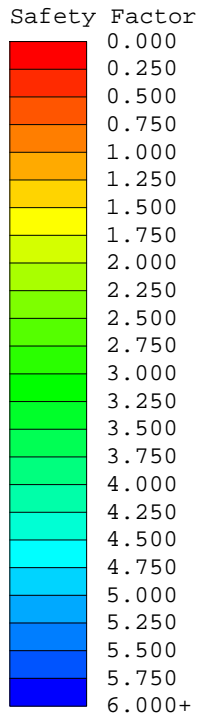

Northeast Slope Empty Undrained.sli

Results
 bishop simplified
 Surface Type: Circular
 Search Method: Grid Search
 Radius Increment: 10
 Composite Surfaces: Disabled
 Reverse Curvature: Create Tension Crack
 Minimum Elevation: Not Defined
 Minimum Depth: Not Defined
 Every available surface
 3.504
 Factor of Safety: 3.504
 Center: 34.448, 370.591
 Radius: 61.724
 Left Slip Surface Endpoint: -21.649, 344.842
 Right Slip Surface Endpoint: 80.119, 329.070

3.504

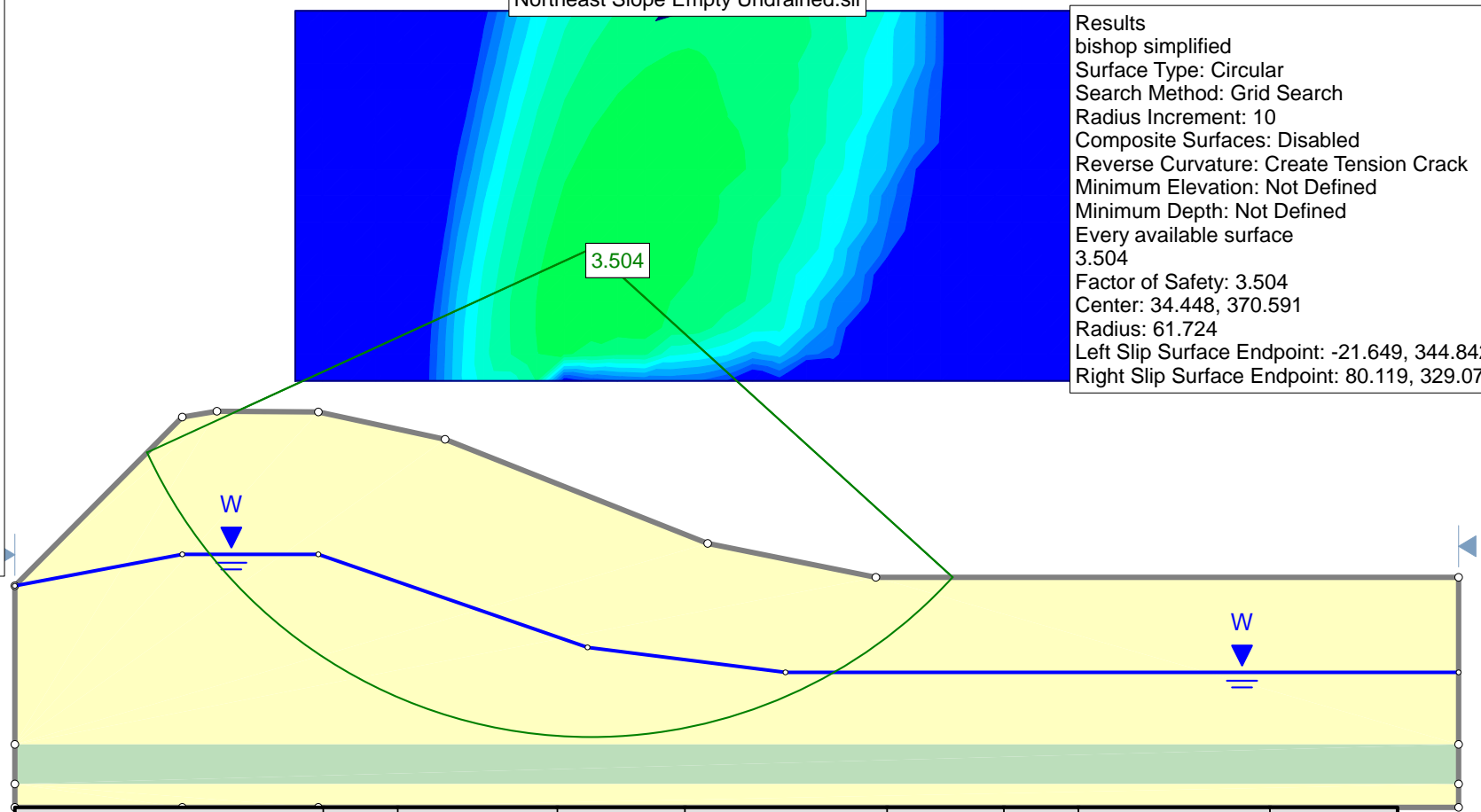

| Material Name | Color | Unit Weight (lbs/ft ³) | Sat. Unit Weight (lbs/ft ³) | Strength Type | Cohesion (psf) | Phi (deg) | Water Surface | Hu Type |
|-------------------------|-------|------------------------------------|---|---------------|----------------|-----------|---------------|----------|
| Clayey Sand/ Sandy Clay | | 127 | 132 | Mohr-Coulomb | 1500 | 0 | Water Surface | Constant |
| Clean Sand | | 127 | 132 | Mohr-Coulomb | 0 | 29 | Water Surface | Constant |

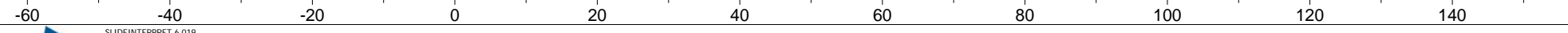

Case 13

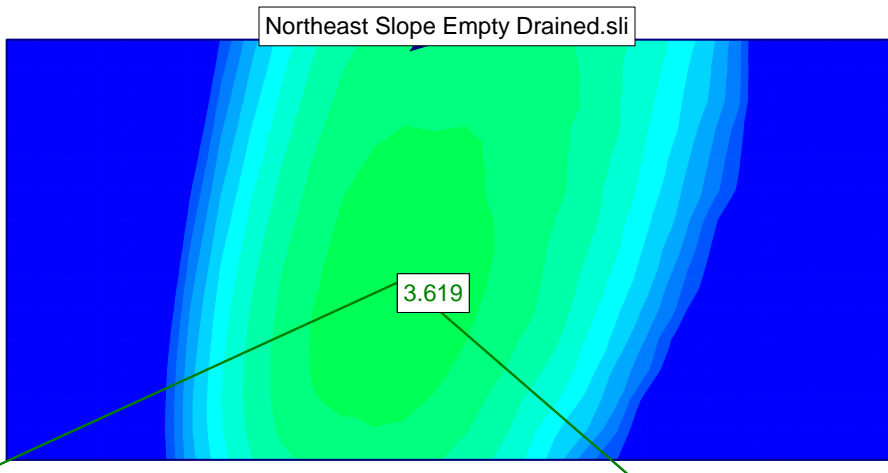
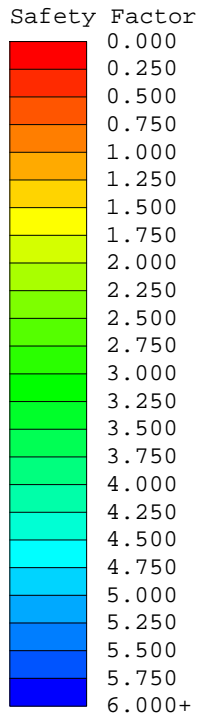

Results
 bishop simplified
 Surface Type: Circular
 Search Method: Grid Search
 Radius Increment: 10
 Composite Surfaces: Disabled
 Reverse Curvature: Create Tension Crack
 Minimum Elevation: Not Defined
 Minimum Depth: Not Defined
 Every available surface
 3.619
 Factor of Safety: 3.619
 Center: 41.243, 373.931
 Radius: 68.481
 Left Slip Surface Endpoint: -21.038, 345.458
 Right Slip Surface Endpoint: 92.983, 329.070

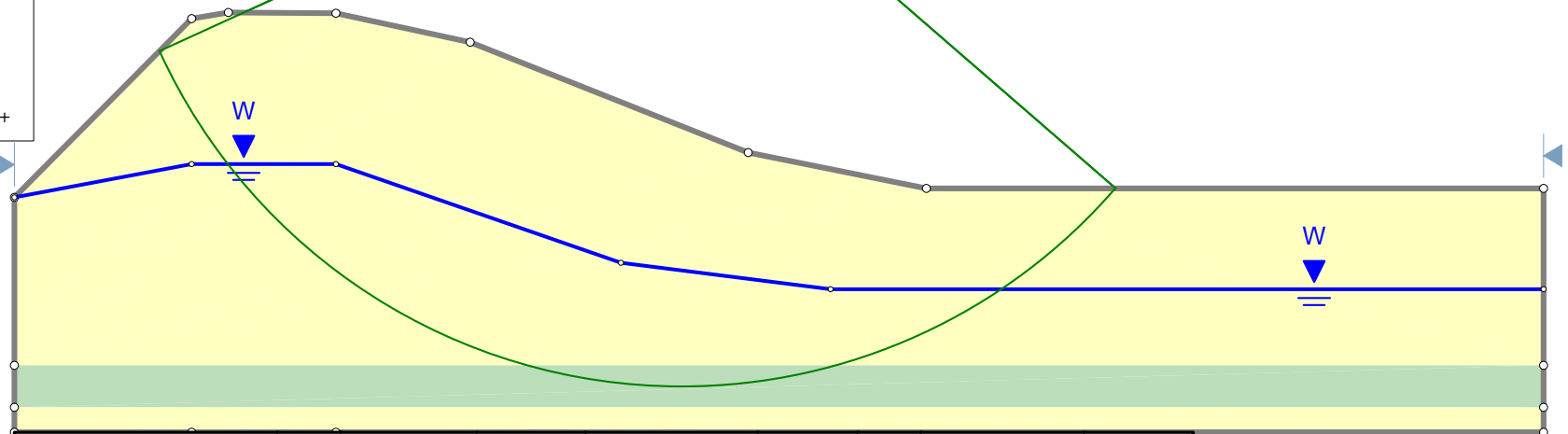

| Material Name | Color | Unit Weight (lbs/ft ³) | Sat. Unit Weight (lbs/ft ³) | Strength Type | Cohesion (psf) | Phi (deg) | Water Surface | Hu Type |
|-------------------------|-------|------------------------------------|---|---------------|----------------|-----------|---------------|----------|
| Clayey Sand/ Sandy Clay | | 127 | 132 | Mohr-Coulomb | 1000 | 14 | Water Surface | Constant |
| Clean Sand | | 127 | 132 | Mohr-Coulomb | 0 | 29 | Water Surface | Constant |

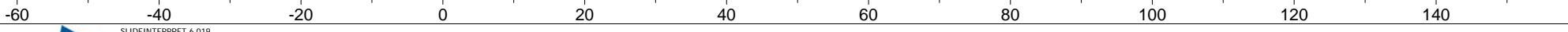

Case 14

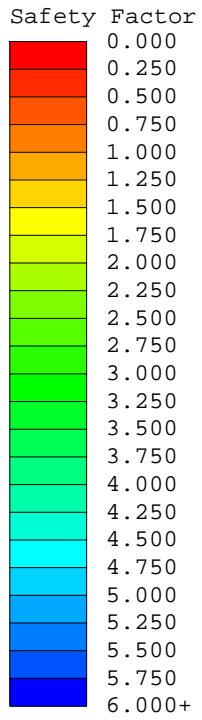

Northeast Slope Full Undrained.sli

Results
 bishop simplified
 Surface Type: Circular
 Search Method: Grid Search
 Radius Increment: 10
 Composite Surfaces: Disabled
 Reverse Curvature: Create Tension Crack
 Minimum Elevation: Not Defined
 Minimum Depth: Not Defined
 Every available surface
 3.488
 Factor of Safety: 3.488
 Center: 41.243, 373.931
 Radius: 73.619
 Left Slip Surface Endpoint: -24.885, 341.576
 Right Slip Surface Endpoint: 99.614, 329.070
 Left Slope Intercept: -24.885 349.330
 Right Slope Intercept: 99.614 329.070

3.488

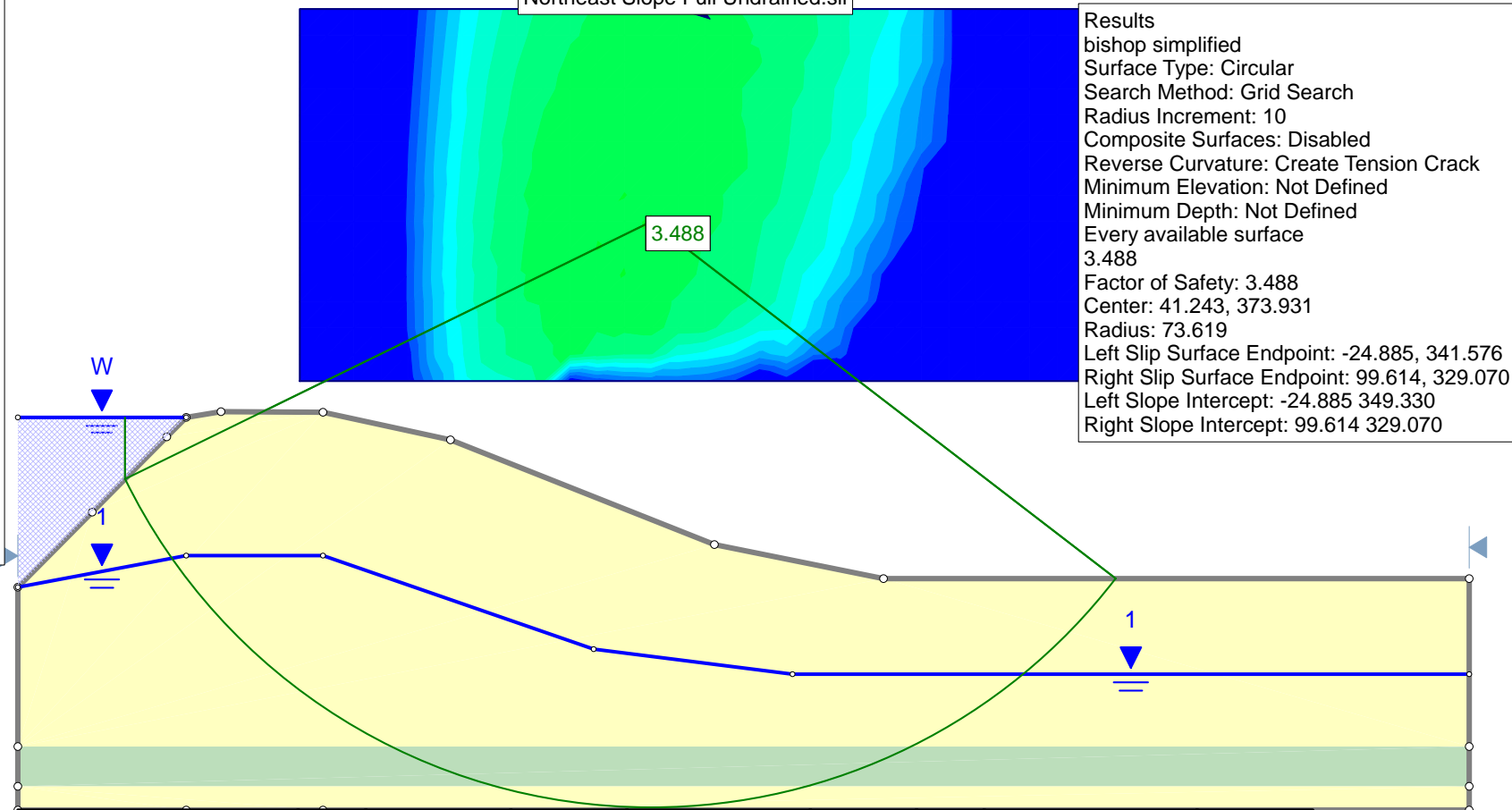

| Material Name | Color | Unit Weight (lbs/ft3) | Sat. Unit Weight (lbs/ft3) | Strength Type | Cohesion (psf) | Phi (deg) | Water Surface | Hu Type |
|-------------------------|-------|-----------------------|----------------------------|---------------|----------------|-----------|--------------------|----------|
| Clayey Sand/ Sandy Clay | | 127 | 132 | Mohr-Coulomb | 1500 | 0 | Piezometric Line 1 | Constant |
| Clean Sand | | 127 | 132 | Mohr-Coulomb | 0 | 29 | Piezometric Line 1 | Constant |

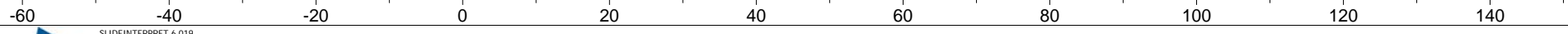

Case 15

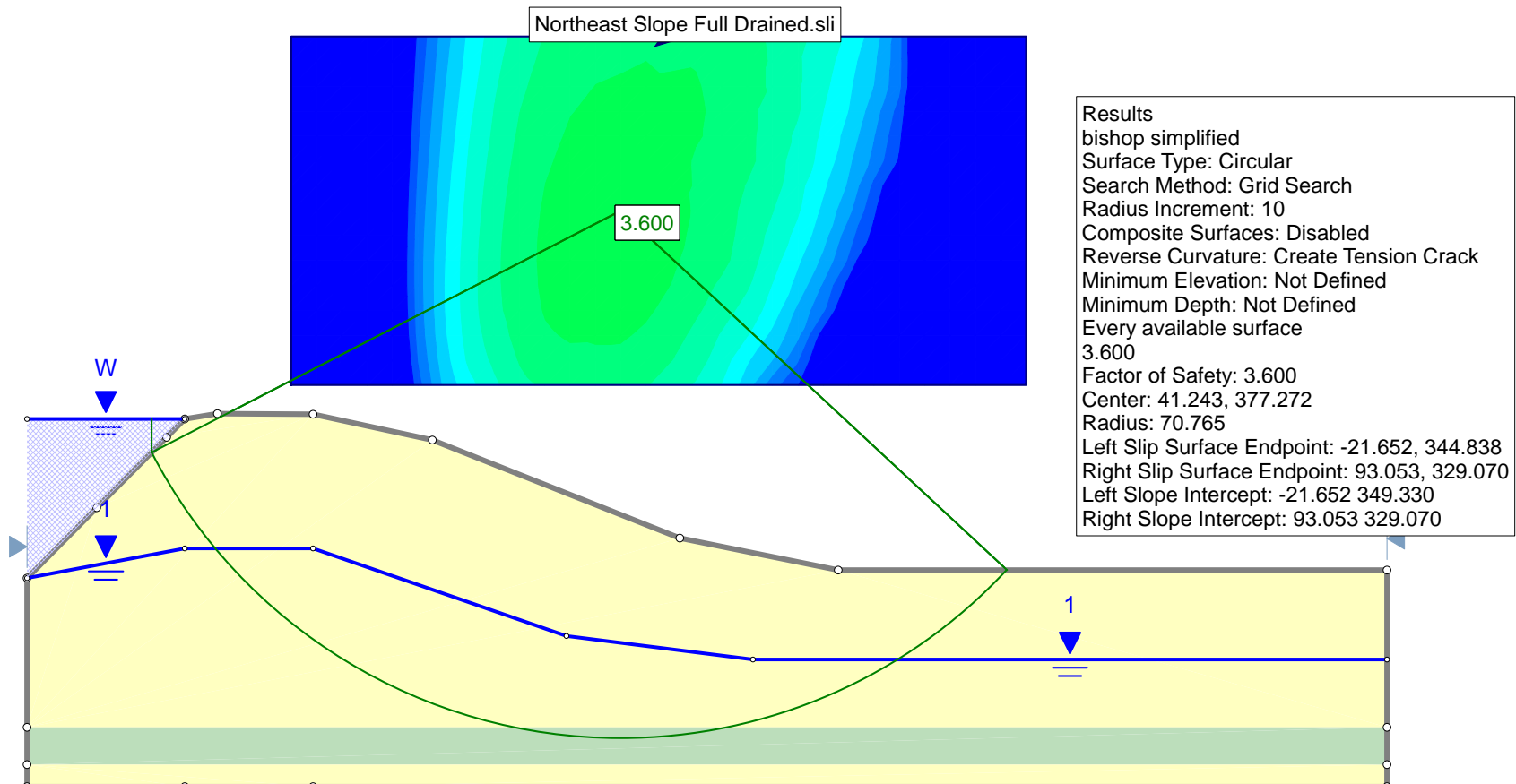
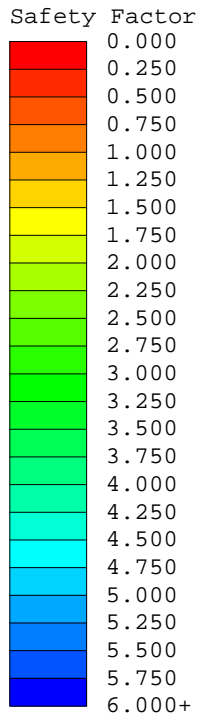

| Material Name | Color | Unit Weight (lbs/ft ³) | Sat. Unit Weight (lbs/ft ³) | Strength Type | Cohesion (psf) | Phi (deg) | Water Surface | Hu Type |
|-------------------------|-------|------------------------------------|---|---------------|----------------|-----------|--------------------|----------|
| Clayey Sand/ Sandy Clay | | 127 | 132 | Mohr-Coulomb | 1000 | 14 | Piezometric Line 1 | Constant |
| Clean Sand | | 127 | 132 | Mohr-Coulomb | 0 | 29 | Piezometric Line 1 | Constant |

Case 16

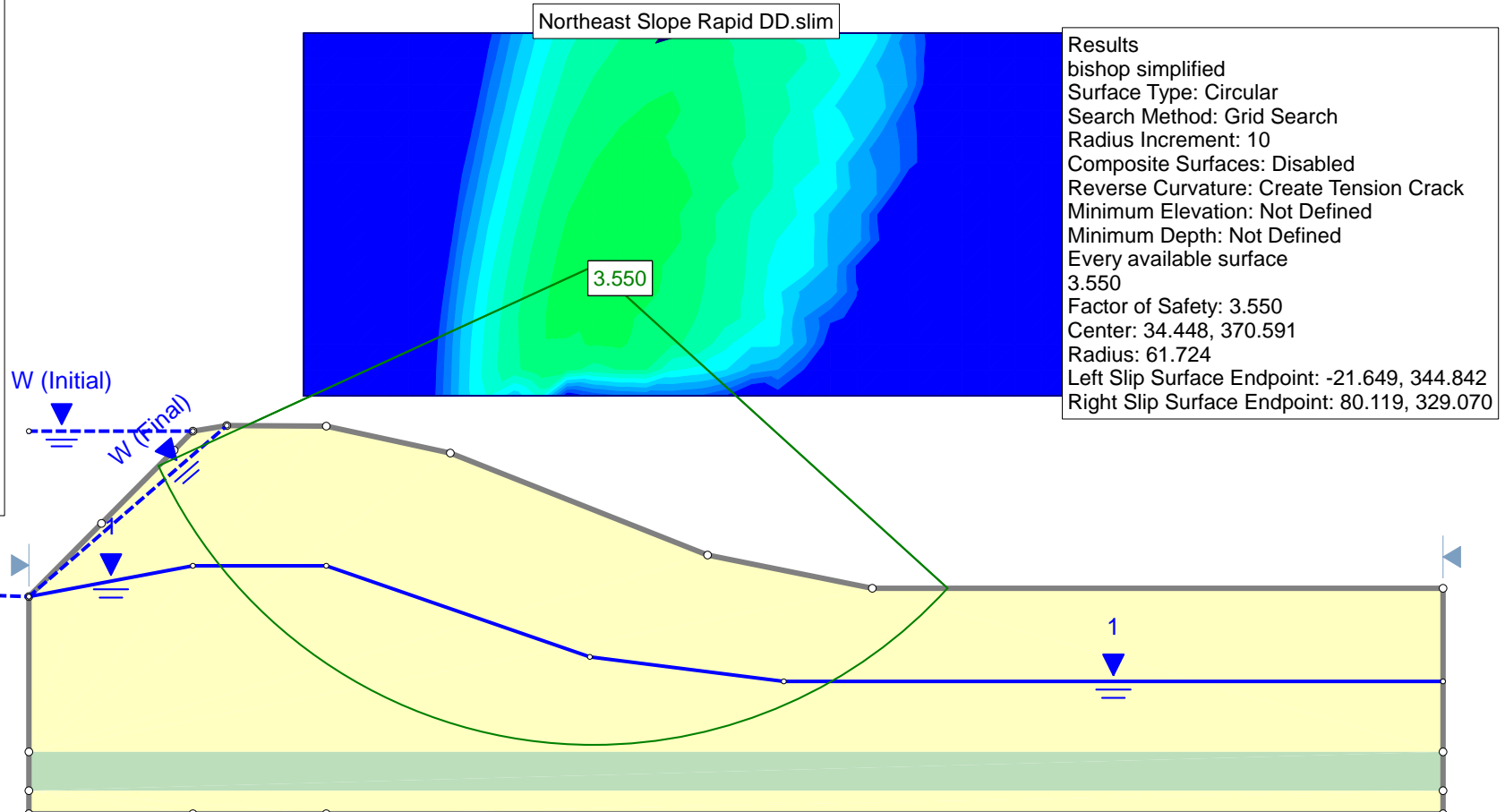
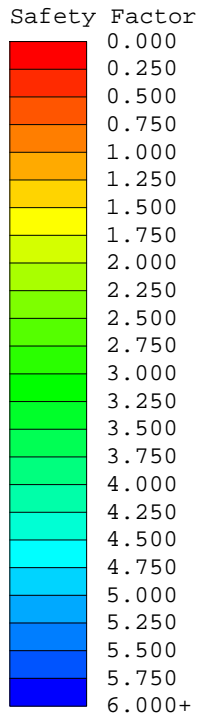

Results
 bishop simplified
 Surface Type: Circular
 Search Method: Grid Search
 Radius Increment: 10
 Composite Surfaces: Disabled
 Reverse Curvature: Create Tension Crack
 Minimum Elevation: Not Defined
 Minimum Depth: Not Defined
 Every available surface
 3.550
 Factor of Safety: 3.550
 Center: 34.448, 370.591
 Radius: 61.724
 Left Slip Surface Endpoint: -21.649, 344.842
 Right Slip Surface Endpoint: 80.119, 329.070

| Material Name | Color | Unit Weight (lbs/ft3) | Sat. Unit Weight (lbs/ft3) | Strength Type | Cohesion (psf) | Phi (deg) | Rapid Drawdown (RD) Undrained Strength | RD Cr (psf) | RD PhiR (deg) | Water Surface | Hu Type |
|-------------------------|-------|-----------------------|----------------------------|---------------|----------------|-----------|--|-------------|---------------|--------------------|----------|
| Clayey Sand/ Sandy Clay | | 127 | 132 | Mohr-Coulomb | 1500 | 0 | Yes | 0 | 0 | Piezometric Line 1 | Constant |
| Clean Sand | | 127 | 132 | Mohr-Coulomb | 0 | 29 | No | | | Piezometric Line 1 | Constant |

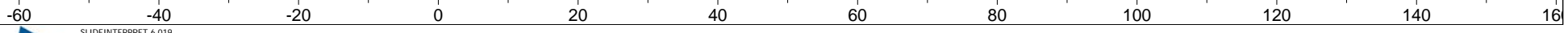

CASE 17

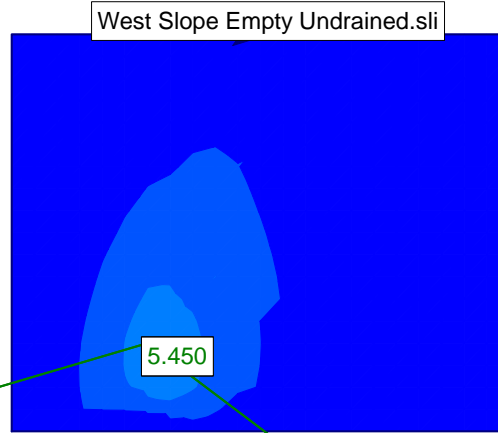
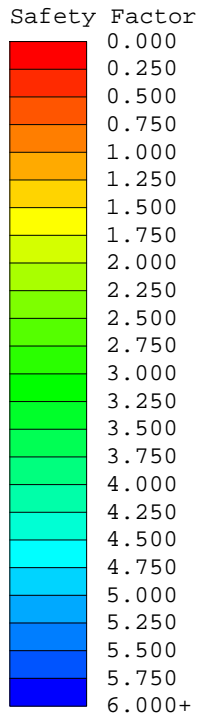

Results
 bishop simplified
 Surface Type: Circular
 Search Method: Grid Search
 Radius Increment: 10
 Composite Surfaces: Disabled
 Reverse Curvature: Create Tension Crack
 Minimum Elevation: Not Defined
 Minimum Depth: Not Defined
 Every available surface
 5.450
 Factor of Safety: 5.450
 Center: 25.067, 358.440
 Radius: 35.622
 Left Slip Surface Endpoint: -9.100, 348.362
 Right Slip Surface Endpoint: 53.507, 336.990

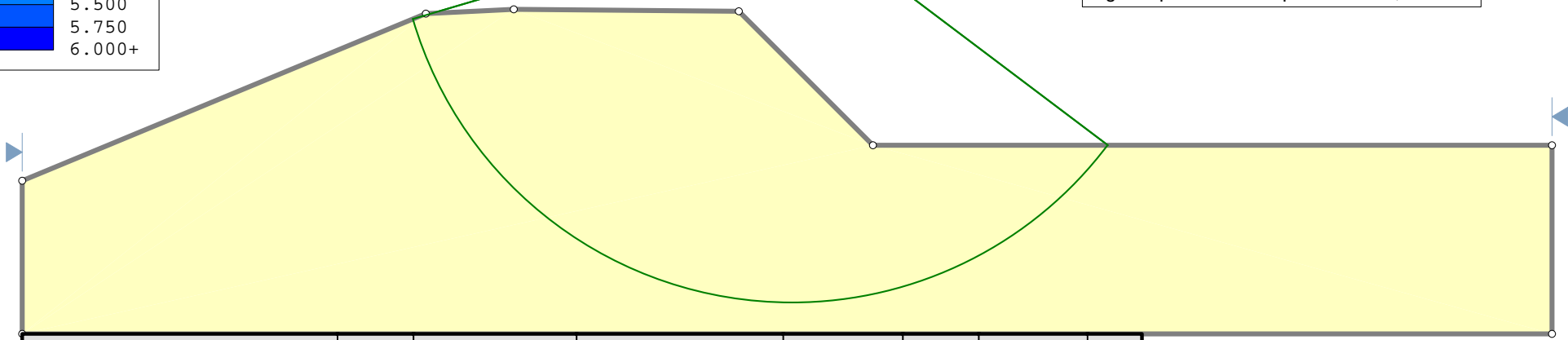

| Material Name | Color | Unit Weight (lbs/ft3) | Strength Type | Cohesion (psf) | Phi (deg) | Water Surface | Ru |
|-------------------------|-------|-----------------------|---------------|----------------|-----------|---------------|----|
| Clayey Sand/ Sandy Clay | | 127 | Mohr-Coulomb | 1500 | 0 | None | 0 |

CASE 18

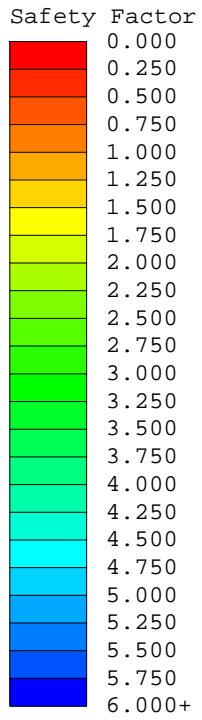

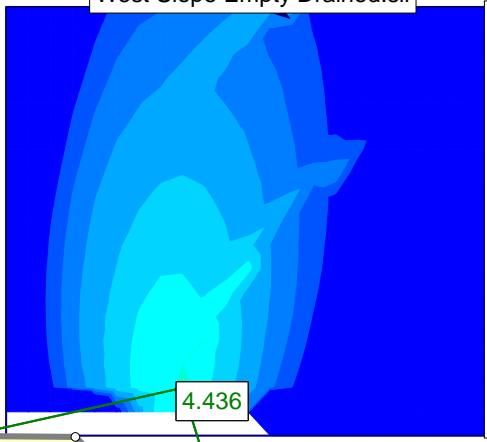

West Slope Empty Drained.sli

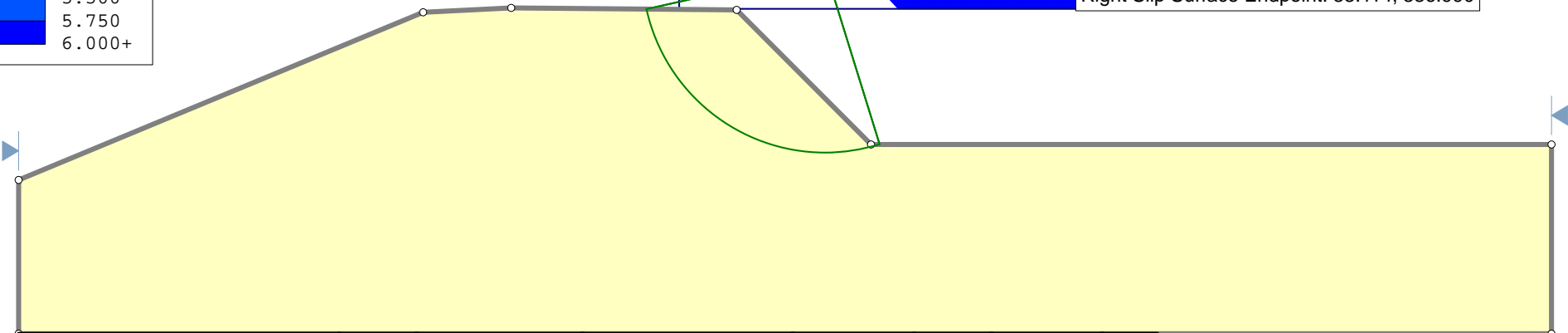

Results
 bishop simplified
 Surface Type: Circular
 Search Method: Grid Search
 Radius Increment: 10
 Composite Surfaces: Disabled
 Reverse Curvature: Create Tension Crack
 Minimum Elevation: Not Defined
 Minimum Depth: Not Defined
 Every available surface
 4.436
 Factor of Safety: 4.436
 Center: 28.226, 352.710
 Radius: 16.463
 Left Slip Surface Endpoint: 12.157, 349.132
 Right Slip Surface Endpoint: 33.114, 336.990

4.436



| Material Name | Color | Unit Weight (lbs/ft3) | Strength Type | Cohesion (psf) | Phi (deg) | Water Surface | Ru |
|-------------------------|---|-----------------------|---------------|----------------|-----------|---------------|----|
| Clayey Sand/ Sandy Clay |  | 127 | Mohr-Coulomb | 1000 | 14 | None | 0 |

-40 -20 0 20 40 60 80

CASE 19

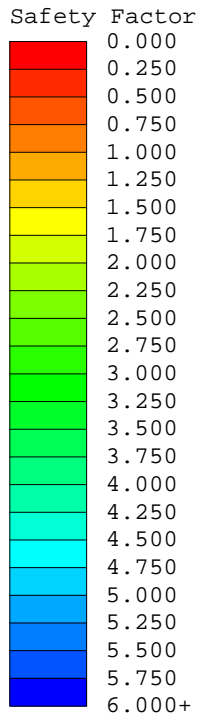

West Slope Full Undrained.sli

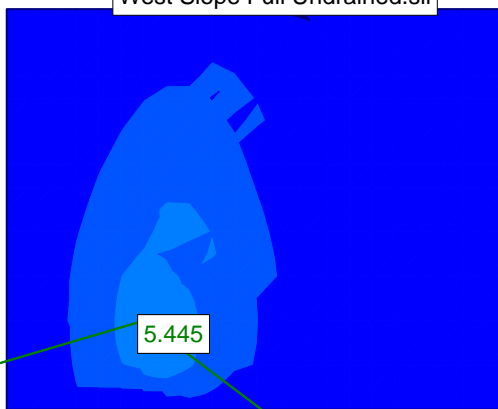

Results
 bishop simplified
 Surface Type: Circular
 Search Method: Grid Search
 Radius Increment: 10
 Composite Surfaces: Disabled
 Reverse Curvature: Create Tension Crack
 Minimum Elevation: Not Defined
 Minimum Depth: Not Defined
 Every available surface
 5.445
 Factor of Safety: 5.445
 Center: 25.067, 358.440
 Radius: 35.622
 Left Slip Surface Endpoint: -9.100, 348.362
 Right Slip Surface Endpoint: 53.507, 336.990
 Left Slope Intercept: -9.100 348.850
 Right Slope Intercept: 53.507 336.990

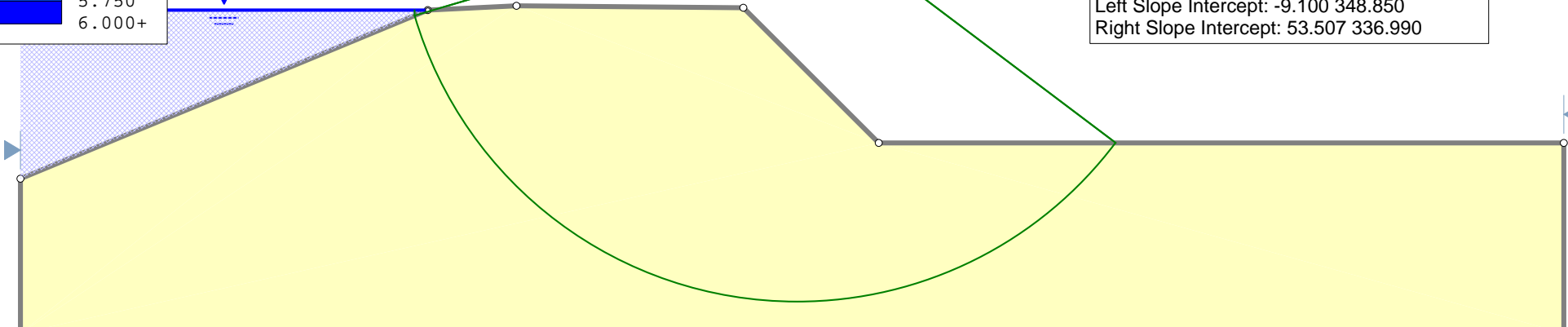

| Material Name | Color | Unit Weight (lbs/ft3) | Strength Type | Cohesion (psf) | Phi (deg) | Water Surface | Ru |
|-------------------------|-------|-----------------------|---------------|----------------|-----------|---------------|----|
| Clayey Sand/ Sandy Clay | | 127 | Mohr-Coulomb | 1500 | 0 | None | 0 |

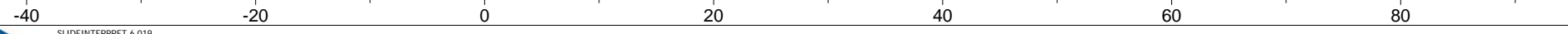

CASE 20

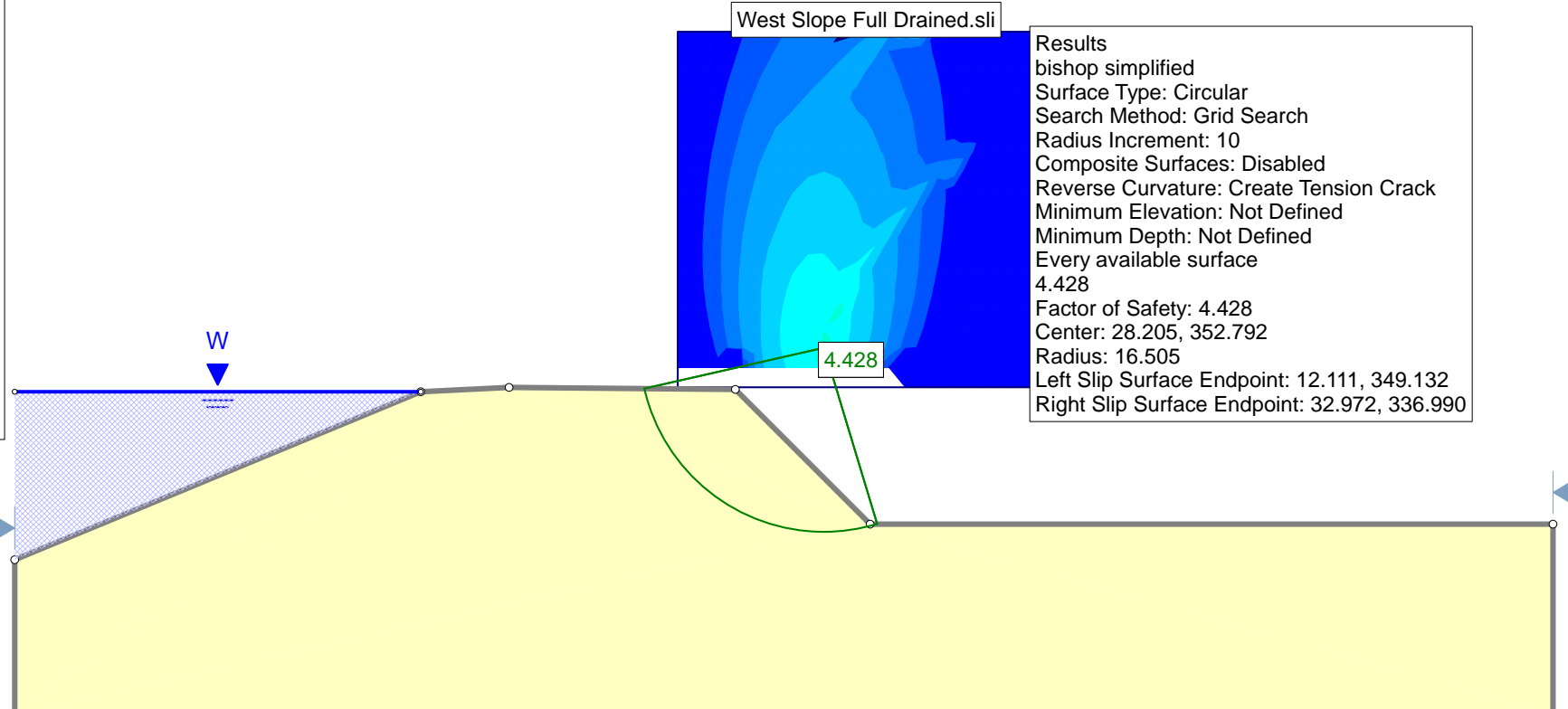
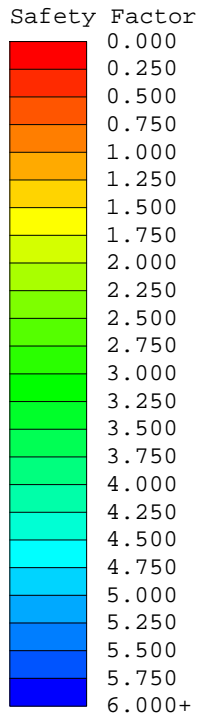

Results
 bishop simplified
 Surface Type: Circular
 Search Method: Grid Search
 Radius Increment: 10
 Composite Surfaces: Disabled
 Reverse Curvature: Create Tension Crack
 Minimum Elevation: Not Defined
 Minimum Depth: Not Defined
 Every available surface
 4.428
 Factor of Safety: 4.428
 Center: 28.205, 352.792
 Radius: 16.505
 Left Slip Surface Endpoint: 12.111, 349.132
 Right Slip Surface Endpoint: 32.972, 336.990

| Material Name | Color | Unit Weight (lbs/ft3) | Sat. Unit Weight (lbs/ft3) | Strength Type | Cohesion (psf) | Phi (deg) | Water Surface | Ru |
|-------------------------|---|-----------------------|----------------------------|---------------|----------------|-----------|---------------|----|
| Clayey Sand/ Sandy Clay |  | 127 | 132 | Mohr-Coulomb | 1000 | 14 | None | 0 |

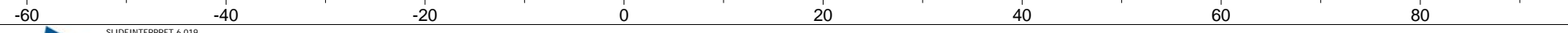

CASE 21

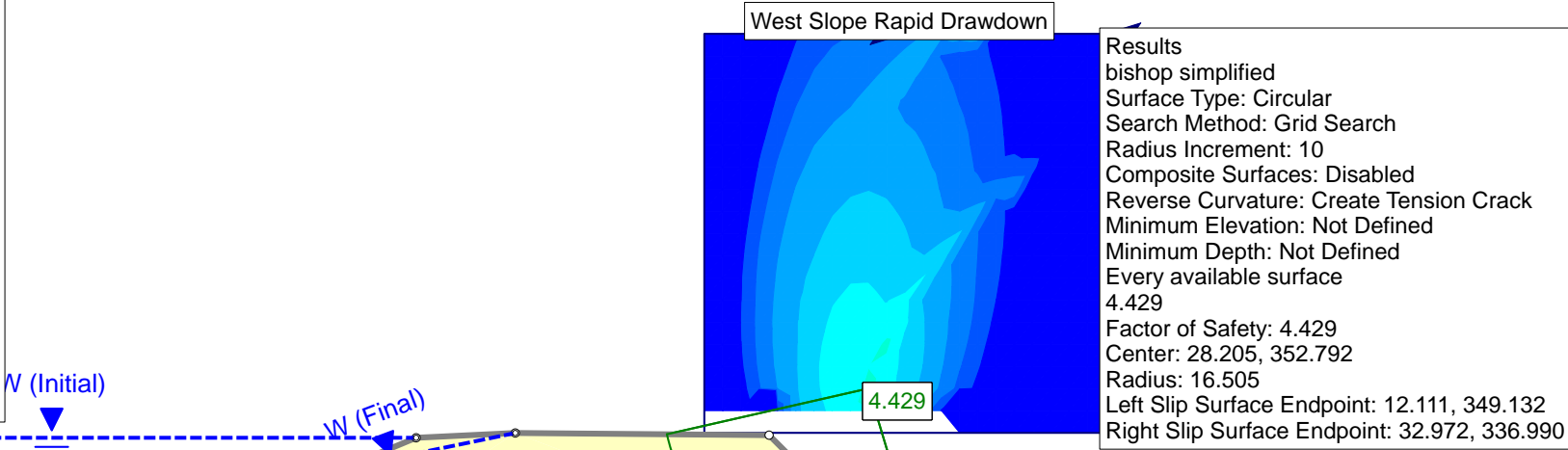
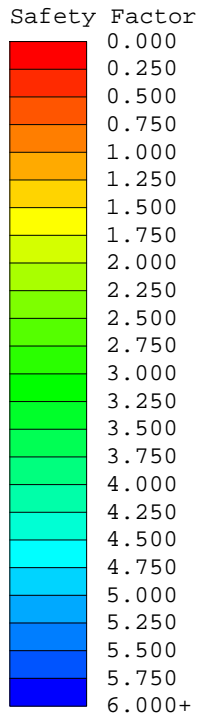

| Material Name | Color | Unit Weight (lbs/ft ³) | Sat. Unit Weight (lbs/ft ³) | Strength Type | Cohesion (psf) | Phi (deg) | Rapid Drawdown (RD) Undrained Strength | RD Cr (psf) | RD PhiR (deg) | Water Surface | Ru |
|-------------------------|-------|------------------------------------|---|---------------|----------------|-----------|--|-------------|---------------|---------------|----|
| Clayey Sand/ Sandy Clay | | 127 | 132 | Mohr-Coulomb | 1000 | 14 | Yes | 0 | 0 | None | 0 |

**APPENDIX E
IMPORTANT INFORMATION ABOUT THIS GEOTECHNICAL REPORT**

Important Information About Your Geotechnical Engineering Report

Subsurface problems are a principal cause of construction delays, cost overruns, claims, and disputes. The following information is provided to help you manage your risks.

Geotechnical Services Are Performed for Specific Purposes, Persons, and Projects

Geotechnical engineers structure their services to meet the specific needs of their clients. A geotechnical engineering study conducted for a civil engineer may not fulfill the needs of a construction contractor or even another civil engineer. Because each geotechnical engineering study is unique, each geotechnical engineering report is unique, prepared solely for the client. *No one except you* should rely on your geotechnical engineering report without first conferring with the geotechnical engineer who prepared it. *And no one - not even you* - should apply the report for any purpose or project except the one originally contemplated.

A Geotechnical Engineering Report Is Based on A Unique Set of Project-Specific Factors

Geotechnical engineers consider a number of unique, Project-specific factors when establishing the scope of a study. Typical factors include the client's goals, objectives, and risk management preferences; the general nature of the structure involved, its size, and configuration; the location of the structure on the site; and other planned or existing site improvements, such as access roads, parking lots, and underground utilities. Unless the geotechnical engineer who conducted the study specifically indicates otherwise, *do not rely on a geotechnical engineering report that was:*

- not prepared for you,
- not prepared for your project.
- not prepared for the specific site explored, or
- completed before important project changes were made.

Typical changes that can erode the reliability of an existing geotechnical engineering report include those that affect:

- the function of the proposed structure, as when it's changed from a parking garage to an office building, or from a light industrial plant to a refrigerated warehouse,
- elevation, configuration, location, orientation, or weight of the proposed structure,
- composition of the design team, or
- project ownership.

As a general rule, always inform your geotechnical engineer of project changes-even minor ones-and request an assessment of their impact. *Geotechnical engineers cannot accept responsibility or liability for problems that occur because their reports do not consider developments of which they were not informed.*

Subsurface Conditions Can Change

A geotechnical engineering report is based on conditions that existed at the time the study was performed. *Do not rely on a geotechnical engineering report* whose adequacy may have been affected by: the passage of time; by man-made events, such as construction on or adjacent to the site; or by natural events, such as floods, earthquakes, or groundwater fluctuations. *Always* contact the geotechnical engineer before applying the report to determine if it is still reliable. A minor amount of additional testing or analysis could prevent major problems.

Most Geotechnical Findings Are Professional Opinions

Site exploration identifies subsurface conditions only at those points where subsurface tests are conducted or samples are taken. Geotechnical engineers review field and laboratory data and then apply their professional judgment to render an *opinion* about subsurface conditions throughout the site. Actual sub-surface conditions may differ - sometimes significantly - from those indicated in your report. Retaining the geotechnical engineer who developed your report to provide construction observation is the most effective method of managing the risks associated with unanticipated conditions

A Report's Recommendations Are *Not* Final

Do not over-rely on the construction recommendations included in your report. Those *recommendations are not final*, because geotechnical engineers develop them principally from judgment and opinion. Geotechnical engineers can finalize their recommendations only by observing actual subsurface conditions revealed during construction. *The geotechnical engineer who developed your report cannot assume responsibility or liability* for the report's recommendations if that engineer does not perform construction observation.

A Geotechnical Engineering Report Is Subject To Misinterpretation

Other design team members' misinterpretation of geotechnical engineering reports has resulted in costly problems. Lower that risk by having your geotechnical engineer confer with appropriate members of the design team after submitting the report. Also retain your geotechnical engineer to review pertinent elements of the design team's plans and specifications. Contractors can also misinterpret a geotechnical engineering report. Reduce that risk by having your geotechnical engineer participate in prebid and preconstruction conferences, and by providing construction observation.

Do Not Redraw the Engineer's Logs

Geotechnical engineers prepare final boring and testing logs based upon their interpretation of field logs and laboratory data. To prevent errors or omissions, the logs included in a geotechnical engineering report should never be redrawn for inclusion in architectural or other design drawings. Only photo graphic or electronic reproduction is acceptable, *but recognize that separating logs from the report can elevate risk.*

Give Contractors a Complete Report and Guidance

Some owners and design professionals mistakenly believe they can make contractors liable for unanticipated subsurface conditions by limiting what they provide for bid preparation. To help prevent costly problems, give contractors the complete geotechnical engineering report, but preface it with a clearly written letter of transmittal. In that letter, advise contractors that the report was not prepared for purposes of bid development and that the report's accuracy is limited; encourage them to confer with the geotechnical engineer who prepared the report (a modest fee may be required) and/or to conduct additional study to obtain the specific types of information they need or prefer. A brand conference can also be valuable. *Be sure contractors have sufficient time* to perform additional study. Only then might you be in a position to give contractors the best information available to you, while requiring them to at least share some of the financial responsibilities stemming from unanticipated conditions.

Read Responsibility Provisions Closely

Some clients, design professionals, and contractors do not recognize that geotechnical engineering is far less exact than other engineering disciplines. This lack of understanding has created unrealistic expectations that have led to disappointments, claims, and disputes. To help reduce such risks, geotechnical engineers commonly include a variety of explanatory provisions in their reports. Sometimes labeled "limitations", many of these provisions indicate where geotechnical engineers responsibilities begin and end, to help others recognize their own responsibilities and risks. Read these provisions closely. Ask questions. Your geotechnical engineer should respond fully and frankly.

Geoenvironmental Concerns Are Not Covered

The equipment, techniques, and personnel used to perform a geoenvironmental study differ significantly from those used to perform a geotechnical study. For that reason, a geotechnical engineering report does not usually relate any geoenvironmental findings, conclusions, or recommendations: e.g., about the likelihood of encountering underground storage tanks or regulated contaminants. *Unanticipated environmental problems have led to numerous project failures.* If you have not yet obtained your own geoenvironmental information, ask your geotechnical consultant for risk management guidance. *Do not rely on an environmental report prepared for someone else.*

Rely on Your Geotechnical Engineer for Additional Assistance

Membership in ASFE exposes geotechnical engineers to a wide army of risk management techniques that can be of genuine benefit for everyone involved with a construction project. Confer with your ASFE-member geotechnical engineer for more information.

ASFE

8811 Colesville Road Suite 3106 Silver Spring, MD 20910
Telephone: 301-565-2733 Facsimile: 301-589-2017
email: info@asde.org www.asfe.org

At Golder Associates we strive to be the most respected global group of companies specializing in ground engineering and environmental services. Employee owned since our formation in 1960, we have created a unique culture with pride in ownership, resulting in long-term organizational stability. Golder professionals take the time to build an understanding of client needs and of the specific environments in which they operate. We continue to expand our technical capabilities and have experienced steady growth with employees now operating from offices located throughout Africa, Asia, Australasia, Europe, North America and South America.

| | |
|---------------|-------------------|
| Africa | + 27 11 254 4800 |
| Asia | + 852 2562 3658 |
| Australasia | + 61 3 8862 3500 |
| Europe | + 356 21 42 30 20 |
| North America | + 1 800 275 3281 |
| South America | + 55 21 3095 9500 |

solutions@golder.com
www.golder.com

US EPA ARCHIVE DOCUMENT

Golder Associates Inc.
500 Century Plaza Drive, Suite 190
Houston, TX 77073 USA
Tel: (281) 821-6868
Fax: (281) 821-6870

