

United States
Environmental Protection
Agency

Office of Air Quality
Planning and Standards
Research Triangle Park NC 27711

EPA-453/R-94-037
June 1994

Air



Alternative Control Techniques Document -- NOx Emissions from Glass Manufacturing

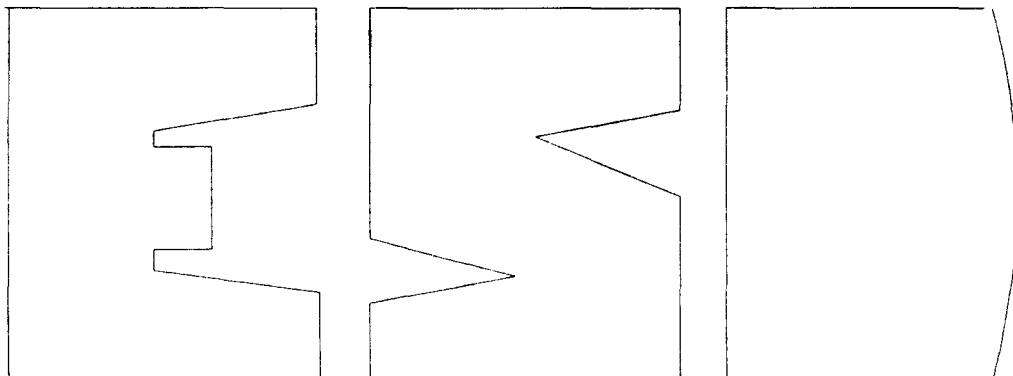
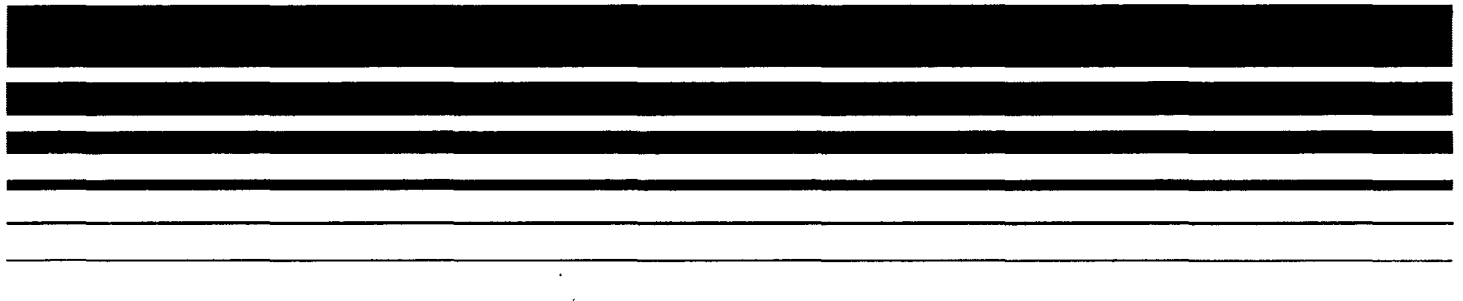

EPA-453/R-94-037

**Alternative Control Techniques Document -
NO_x Emissions from Glass Manufacturing**

EMISSION STANDARDS DIVISION

**U.S. Environmental Protection Agency
Region 5, Library (PL-12J)
77 West Jackson Boulevard, 12th Floor
Chicago, IL 60604-3590**

**U.S. ENVIRONMENTAL PROTECTION AGENCY
Office of Air and Radiation
Office of Air Quality Planning and Standards
Research Triangle Park, North Carolina 27711
June 1994**

4/22/94
310-33

1121 Environmental Protection Agency
Region 5, Boston (617 373)
225 North Street, Boston, MA 02111
(617 373 3000)

ALTERNATIVE CONTROL TECHNIQUES DOCUMENTS

This report is issued by the Emission Standards Division, Office of Air Quality Planning and Standards, U. S. Environmental Protection Agency, to provide information to State and local air pollution control agencies. Mention of trade names and commercial products is not intended to constitute endorsement or recommendation for use. Copies of this report are available--as supplies permit--from the Library Services Office (MD-35), U. S. Environmental Protection Agency, Research Triangle Park, North Carolina 27711 ([919] 541-2777) or, for a nominal fee, from the National Technical Information Service, 5285 Port Royal Road, Springfield, VA 22161 ([800] 553-NTIS).

TABLE OF CONTENTS

Chapter		Page
	LIST OF FIGURES	iv
	LIST OF TABLES	vi
1	INTRODUCTION	1-1
2	SUMMARY	2-1
	2.1 UNCONTROLLED NO _x EMISSIONS	2-1
	2.2 NO _x CONTROL TECHNIQUES AND CONTROLLED EMISSION LEVELS	2-3
	2.3 COSTS/COST EFFECTIVENESS OF NO _x CONTROLS	2-3
	2.4 IMPACTS OF NO _x CONTROLS	2-7
	2.4.1 Environmental Impacts	2-7
	2.4.1.1 Combustion Modifications	2-7
	2.4.1.2 Process Modifications	2-7
	2.4.1.3 Postcombustion Modifications	2-7
	2.4.2 Energy Impacts	2-9
	2.4.2.1 Combustion Modifications	2-9
	2.4.2.2 Process Modifications	2-9
	2.4.2.3 Postcombustion Modifications	2-11
3	GLASS MANUFACTURING	3-1
	3.1 BACKGROUND	3-1
	3.2 GLASS MAKING	3-1
	3.3 OVERVIEW OF THE GLASS-MAKING INDUSTRY	3-11
	3.3.1 Container Glass	3-13
	3.3.2 Flat Glass	3-13
	3.3.3 Pressed/Blown Glass	3-13
	3.4 REFERENCES	3-17
4	CHARACTERIZATION OF NO _x EMISSIONS	4-1
	4.1 NO _x FORMATION	4-1
	4.1.1 Homogeneous NO _x Formation	4-1
	4.1.2 NO _x from Nitrates	4-5
	4.1.3 NO _x from Fuel/Oxidizer	4-5
	4.2 FACTORS AFFECTING NO _x EMISSIONS	4-5
	4.2.1 NO _x Generation Rate	4-6
	4.2.2 Normalized NO _x Emissions	4-7
	4.3 UNCONTROLLED NO _x EMISSIONS	4-10
	4.4 REFERENCES	4-13

TABLE OF CONTENTS (continued)

Chapter		Page
5	CONTROL TECHNIQUES FOR NITROGEN OXIDES FROM GLASS MELTING	5-1
	5.1 INTRODUCTION	5-1
	5.2 COMBUSTION MODIFICATIONS	5-1
	5.2.1 Modifications to Existing Burners	5-3
	5.2.1.1 Low Excess Air (LEA) Operation	5-3
	5.2.1.2 Changing Air/Fuel Contacting	5-3
	5.2.2 Modified Burners	5-10
	5.2.2.1 Sorg Burner	5-13
	5.2.2.2 Körting Burner	5-17
	5.2.3 Oxygen Enrichment/Oxy-Firing	5-17
	5.3 PROCESS MODIFICATIONS	5-31
	5.3.1 Modified Furnace	5-31
	5.3.1.1 Teichmann System	5-31
	5.3.2 Cullet/Batch Preheat	5-34
	5.3.2.1 Tecogen System	5-38
	5.3.2.2 Zippe System	5-45
	5.3.2.3 Nienburger System	5-45
	5.3.3 Electric Boost/Electric Melting	5-47
	5.4 POSTCOMBUSTION MODIFICATIONS	5-49
	5.4.1 Selective Catalytic Reduction (SCR)	5-49
	5.4.2 Selective Noncatalytic Reduction (SNCR)	5-53
	5.5 SUMMARY	5-56
	5.6 REFERENCES	5-65
6	COSTS OF NO_x CONTROLS	6-1
	6.1 INTRODUCTION	6-1
	6.2 PROCESS MODIFICATIONS	6-3
	6.2.1 Low NO _x Burners	6-3
	6.2.2 Oxy-Firing	6-3
	6.3 PROCESS MODIFICATIONS	6-3
	6.3.1 Cullet Preheat	6-3
	6.3.2 Electric Boost	6-5
	6.4 POSTCOMBUSTION MODIFICATION	6-6
	6.4.1 Selective Catalytic Reduction	6-6
	6.4.2 Selective Noncatalytic Reduction	6-7
	6.5 SUMMARY	6-8
	6.6 REFERENCES	6-9
7	ENVIRONMENTAL AND ENERGY IMPACTS OF NO_x CONTROLS	7-1
	7.1 AIR POLLUTION IMPACTS	7-1
	7.1.1 NO _x Emission Reductions	7-1
	7.1.2 Emissions Tradeoffs	7-1
	7.1.2.1 Combustion Modifications	7-1
	7.1.2.2 Process Modifications	7-5
	7.1.2.3 Postcombustion Modifications	7-7

TABLE OF CONTENTS (continued)

Chapter	Page
7.2 ENERGY IMPACTS	7-10
7.2.1 Combustion Modifications	7-10
7.2.1.1 Modifications to Existing Burners	7-10
7.2.1.2 Low NO _x Burners	7-10
7.2.1.3 Oxy-firing	7-10
7.2.2 Process Modifications	7-12
7.2.2.1 Cullet Preheat	7-12
7.2.2.2 Electric Boost	7-14
7.2.3 Postcombustion Modifications	7-14
7.2.3.1 Selective Catalytic Reduction	7-14
7.2.3.2 Selective Noncatalytic Reduction	7-15
7.3 REFERENCES	7-16

LIST OF FIGURES

Number		Page
2-1	Energy impact of oxy-firing	2-10
3-1	Side-port continuous regenerative furnace	3-3
3-2	End-port continuous regenerative furnace	3-4
3-3	Container glass production	3-6
3-4	Flat glass production	3-7
3-5	Pressed and blown glass production	3-9
3-6	Glass industry—Distribution of plants by State and product line: 1988	3-12
3-7	Estimated capacity of U.S. glass container melters: 1988 (short tons per day)	3-15
4-1	Generation of NO _x	4-4
4-2	Relationship between equivalence ratio and adiabatic flame temperature	4-8
4-3	Relationship between air/fuel ratio for natural gas fuel and NO _x concentration normalized to combustion zone conditions	4-9
5-1	Effect of excess oxygen on concentration of NO _x	5-4
5-2	Effect of excess air level on NO _x	5-5
5-3	Glass furnace burner configuration	5-7
5-4	Agreement of normalized commercial data with modified mixing factor correlation	5-11
5-5	Effect of fuel injection velocity on emission of NO _x	5-12
5-6	Low-nitrogen oxides burner with multistage combustion	5-14
5-7	Sorg Cascade burner	5-16
5-8	Air staging on a regenerative horseshoe-fired furnace	5-18
5-9	Körting gas jet	5-19
5-10	Flue gas recirculation on regenerative glass melting furnaces	5-20
5-11	Adiabatic equilibrium NO (given in lb/MM Btu) versus percent oxygen in the oxidizer for a methane flame based on gross energy input (overall firing rate) and net energy into the product	5-23
5-12	Adiabatic flame temperature versus percent oxygen in the oxidizing stream consisting of oxygen and nitrogen	5-25
5-13	Adiabatic equilibrium NO given in ppm and lb/MM Btu (gross firing rate) versus percent oxygen in the oxidizer for a methane flame	5-27
5-14	Flue nitric oxide versus percent oxygen in the oxidizer for an Air Products' K-Tech burner firing on natural gas	5-28
5-15	General arrangement of Teichmann/Sorg LoNO _x TM furnace	5-33
5-16	Crossflow cullet preheater	5-35
5-17	Cullet preheater energy balance	5-36
5-18	Cullet preheater concept by Tecogen	5-39
5-19	Production increase available with preheated cullet	5-40
5-20	Reduction in specific NO _x emissions with cullet preheat	5-41
5-21	Fluidized-bed glass batch preheater	5-42

LIST OF FIGURES (continued)

Number		Page
5-22	The glass batch preheater system installed at Foster Forbes	5-44
5-23	Flow diagram of the Nienburger batch preheater	5-46
5-24	Rate of NO _x emissions versus load for 928 ft ² amber glass furnace	5-48
5-25	Unit cell detail of a monolith SCR catalyst	5-51
5-26	Installation of SCR unit on glass furnace	5-52
5-27	PPG SNCR process	5-55
7-1	NO _x and CO concentrations of the flue gas as a function of the oxygen content from an end-fired regenerative furnace	7-2
7-2	Concentration of the flue gas as a function of the staged-air proportion (left side fired) from an end-fired regenerative furnace	7-4
7-3	Available heat as a function of flue gas temperature	7-11
7-4	Energy impact of oxy-firing	7-13

LIST OF TABLES

Number		Page
2-1	UNCONTROLLED NO _x EMISSIONS	2-2
2-2	NO _x EMISSION REDUCTIONS FOR VARIOUS TECHNOLOGIES	2-4
2-3	CAPITAL AND ANNUAL COSTS FOR NO _x CONTROL TECHNOLOGIES	2-5
2-4	COST EFFECTIVENESS - NO _x CONTROL TECHNOLOGIES FOR GLASS FURNACES	2-6
2-5	EFFECT OF OXY-FIRING ON AIR EMISSIONS	2-8
3-1	GLASS PRODUCTION IN 1988	3-11
3-2	PRINCIPAL FEATURES OF MAJOR COMPANIES IN THE CONTAINER SEGMENT	3-14
3-3	PRINCIPAL U.S. COMPANIES PRODUCING FLAT GLASS	3-16
3-4	PRINCIPAL U.S. COMPANIES PRODUCING PRESSED AND BLOWN GLASS TABLEWARE AND KITCHENWARE	3-16
4-1	CALCULATED EQUILIBRIUM CONCENTRATIONS OF NO AND NO ₂ IN AIR AND FLUE GAS	4-2
4-2	UNCONTROLLED NO _x EMISSIONS	4-11
5-1	EFFECT OF EXCESS AIR ON NO _x IN COMMERCIAL FURNACES	5-6
5-2	REPRESENTATIVE TEST CONDITIONS	5-9
5-3	RESULTS OF NO _x TESTS USING CASCADE™ BURNER	5-15
5-4	EFFECT OF BURNER MODIFICATION ON NO _x EMISSIONS	5-21
5-5	NO _x EMISSIONS—75 TPD GLASS FURNACE	5-30
5-6	NO _x EMISSION FROM OXY-FIRING	5-32
5-7	NO _x EMISSIONS FOR FURNACE WITH TEICHMANN LoNO _x FURNACE	5-37
5-8	CURRENT SNCR INSTALLATIONS ON GLASS-MELTING FURNACES	5-57
5-9	SUMMARY OF NO _x EMISSION REDUCTIONS FOR VARIOUS TECHNOLOGIES	5-58
5-10	CONTROLLED NO _x PERCENT REDUCTION USED FOR CALCULATING COST EFFECTIVENESS	5-63
5-11	STATUS OF NO _x CONTROL TECHNOLOGIES FOR VARIOUS GLASS FURNACES	5-64
6-1	CONTROLLED NO _x EMISSION LEVELS USED FOR CALCULATING COST EFFECTIVENESS	6-2
6-2	MODEL GLASS MELTING FURNACES	6-2
6-3	COSTS AND COST EFFECTIVENESS OF RETROFIT LOW NO _x BURNERS	6-4
6-4	COSTS AND COST EFFECTIVENESS OF OXY-FIRING	6-4
6-5	COSTS AND COST EFFECTIVENESS FOR CULLET PREHEAT	6-5

LIST OF TABLES (continued)

Number		Page
6-6	COSTS AND COST EFFECTIVENESS OF ELECTRIC BOOST	6-6
6-7	COSTS AND COST EFFECTIVENESS FOR SCR	6-7
6-8	COSTS AND COST EFFECTIVENESS FOR SNCR	6-8
6-9	SUMMARY OF COST EFFECTIVENESS FOR NO _x CONTROL TECHNOLOGIES FOR GLASS FURNACES	6-8
7-1	EFFECT OF OXY-FIRING ON AIR EMISSIONS	7-6
7-2	SUMMARY OF AFG-VICTORVILLE TESTS OF SNCR	7-9

CHAPTER 1

INTRODUCTION

Congress, in the Clean Air Act Amendments of 1990 (CAAA), amended Title I of the Clean Air Act (CAA) to address ozone nonattainment areas. A new Subpart 2 was added to Part D of Section 103. Section 183(c) of the new Subpart 2 provides that:

[w]ithin 3 years after the date of the enactment of the [CAAA], the Administrator shall issue technical documents which identify alternative controls for all categories of stationary sources of . . . oxides of nitrogen which emit, or have the potential to emit 25 tons per year or more of such air pollutant.

These documents are to be subsequently revised and updated as determined by the Administrator.

Glass-melting furnaces have been identified as stationary sources that emit more than 25 tons of nitrogen oxides (NO_x) per year. This alternative control technique (ACT) document provides technical information for use by State and local agencies to develop and implement regulatory programs to control NO_x emissions from glass melting furnaces. Additional ACT documents are being or have been developed for other stationary source categories.

The information in this ACT document was generated from previous EPA documents and literature searches and contacts with glass manufacturers, engineering firms, control equipment vendors, and Federal, State, and local regulatory agencies. Chapter 2 presents a summary of the findings of this study. Chapter 3 provides a process description and industry characterization of glass manufacturing. A discussion of uncontrolled NO_x emission levels is presented in Chapter 4. Alternative control techniques and achievable controlled emission levels are discussed in Chapter 5. Chapter 6 presents control costs and cost effectiveness for each control technique. Environmental and energy

impacts associated with the use of NO_x control techniques are discussed in Chapter 7.

CHAPTER 2

SUMMARY

This chapter presents a summary of the information contained in this ACT document. Specifically, Section 2.1 presents uncontrolled NO_x emissions, Section 2.2 discusses NO_x emission reductions from various technologies, Section 2.3 summarizes their costs and cost effectiveness, and Section 2.4 presents the impacts of NO_x controls.

2.1 UNCONTROLLED NO_x EMISSIONS

NO_x emissions are generated in the melting furnace in glass plants by the homogeneous gas-phase reaction of oxygen and nitrogen present in the combustion gas, at the high temperatures inherent to this process. Such "thermal NO_x" is essentially all in the form of NO with very little NO₂. Because natural gas is used as the fuel in almost all glass furnaces, there is little contribution of fuel bound nitrogen to NO_x emissions. However, some glass raw materials contain nitrates ("niter") which may emit NO₂ when heated.

Uncontrolled NO_x emissions depend primarily on various process parameters including fuel firing rate, furnace geometry, fuels used, and raw materials. NO_x emissions can vary significantly from site-to site and from furnace to furnace. Uncontrolled emissions of thermal NO_x range from 8 to 10 lb NO_x/ton glass produced. This range is for regenerative container glass furnaces and will vary considerably depending on furnace age, electric boost, batch/cullet ratio, and from site to site even for nominally similar furnaces. Assuming a heat requirement of 6 MM Btu/ton glass, these emissions would correspond to 1.3 to 1.7 lb NO_x/MM Btu. As a general rule, NO_x emissions from large flat glass furnaces are lower and from smaller pressed/blown furnaces would be higher. NO₂ from nitrates is of the order of 0.36 lb NO_x per lb niter (as NaNO₃) in the batch formulation.

Table 2-1 summarizes uncontrolled NO_x emissions from container, flat, and pressed/blown glass furnaces. Emissions range from 2.7 to 27.2 lb NO_x/ton glass. This wide range reflects the effects of furnace type, age, and combustion characteristics on NO_x emissions.

TABLE 2-1. UNCONTROLLED NO_x EMISSIONS

Company (plant location)	Type of glass produced	Design capacity (tons/day)	Type of furnace	Uncontrolled NO _x emissions (lb/ton)
<u>Container</u>				
American National Can	containers	161-458	NR	2.5-10.9
Anchor Glass	containers	137-624	NR	2.7-21
Carr Lowrey (Baltimore, MD)	drug, food, cosmetic bottles	75	end-port	21.6
Diamond Bathurst	flint container glass	250	side-port	12
Gallo Glass (Modesto, CA)	wine bottles	400	side-port	5.19
Owens-Brockway	containers	177-500	NR	1.8-20.5
<u>Flat</u>				
AFG (Spring Hill, KS) (Church Hill, TN)	flat glass	552	NR	8.8
#2 furnace (Victorville, CA)	flat glass	552	NR	17.8
Ford Motor (Tulsa, OK)	flat glass	552		13.0-15.2
2 furnaces		confidential	side-port	11.8 - 15.4
Libbey-Owens-Ford (Lathrop, CA) (Laurinburg, NC)	flat glass	confidential	side-port	9.8 - 13.2
2 furnaces (Ottawa, IL) (Rosford, OH)	flat glass	confidential	side-port	10.4 - 20.3
PPG (Fresno, CA) (Mt. Zion, IL)	flat glass	500	side-port	17.5 - 21.5
	flat glass	750	side-port	16.3 - 23.3
			NR	22.3 - 23.6
<u>Pressed/blown</u>				
GTE Products (Versailles, KY)				10.7 - 14.0
#1 furnace	specialty glass	226		16.8
#2 furnace	specialty glass	66		27.2

For the purpose of calculating the effect of NO_x control technologies, uncontrolled NO_x emissions were based on furnace type and are defined as follows (lb NO_x/ton): container - 10.0; flat - 15.8; pressed/blown - 22.0.

2.2 NO_x CONTROL TECHNIQUES AND CONTROLLED EMISSION LEVELS

Three types of NO_x control technologies were identified:

- combustion modifications
 - oxy-firing
 - low NO_x burners
- process modifications
 - cullet preheat
 - electric boost
- postcombustion modifications
 - selective catalytic reduction (SCR)
 - selective noncatalytic reduction (SNCR)

Table 2-2 (which also appears as Table 6-1 in Chapter 6) shows the NO_x emission reductions reported for each of these technologies based on uncontrolled emissions. Oxy-firing appears to be the most effective NO_x control technique, achieving reductions of over 90 percent. Electric boost, which substitutes electrical energy for thermal energy, is widely used in container glass furnaces, but not in flat glass furnaces. NO_x reductions for cullet preheating vary substantially. Low NO_x burners are relatively effective and simple to install. High levels of emission reduction are also reported for SCR. SNCR is presently used at three US flat glass plants and the NO_x reductions are comparable to low NO_x burners.

2.3 COSTS/COST EFFECTIVENESS OF NO_x CONTROLS

Table 2-3 presents the capital and annual costs for NO_x control technologies. These costs, of course, vary with plant size. Table 2-4 (which also appears as Table 6-9 in Chapter 6) shows the cost effectiveness of the NO_x control technologies considered here. Low NO_x burners, cullet preheat, and SNCR have comparable cost effectiveness with values ranging from around \$700 to \$1,920/ton NO_x removed for the three technologies for the three model plants considered. SCR is the next most cost effective

TABLE 2-2. NO_x EMISSION REDUCTIONS FOR VARIOUS TECHNOLOGIES

Technology	NO _x reduction (%)
Combustion modifications Low NO _x burners Oxy-firing	40 85
Process modifications Modified furnace Cullet preheat Electric boost	75 25 10
Postcombustion modifications SCR SNCR	75 40

TABLE 2-3. CAPITAL AND ANNUAL COSTS FOR NO_x CONTROL TECHNOLOGIES

Plant size (tons/day)	Low NO _x burners		Oxy-firing		Cullet Preheat		Electric boost	SCR		SNCR	
	C ^a \$10 ³	A ^b \$10 ³ /yr	C \$10 ³	A ^b \$10 ³ /yr	C \$10 ³	A ^b \$10 ³ /yr	A ^b \$10 ³ /yr	C \$10 ³	A ^b \$10 ³ /yr	C \$10 ³	A ^b \$10 ³ /yr
50 (pressed/ blown)	265	123	1,930	706	188 ^d	42 ^d	178	528 ^d	404 ^d	310 ^d	130 ^d
250 (container)	695	320	5,070	1,860	492	110	339	1,390	769	810 ^d	340 ^d
750 (flat)	1,340 ^d	621 ^d	9,810 ^d	3,590 ^d	NF ^c	NF	525	2,690 ^d	1,200 ^d	1,560	660

^aC = Capital cost

^bA = Annual cost

^cNF = Not feasible

^d Not demonstrated

TABLE 2-4. COST EFFECTIVENESS - NO_x CONTROL TECHNOLOGIES FOR GLASS FURNACES

Plant size (ton/day)	Cost effectiveness (\$/ton NO _x reduced) (January 1994\$)					
	Low NO _x burners	Oxy-firing	Cullet preheat	Electric boost	SCR	SNCR
50 (pressed/blown)	1,680	4,400	890 ^b	9,900	2,950 ^b	1,770 ^b
250 (container)	1,920	5,300	1,040	8,060	2,460	2,000 ^b
750 (flat)	790 ^b	2,150 ^b	NF ^a	2,600	800 ^b	830 ^b (990 - 1700) ^c

^aNot feasible

^bNot demonstrated

^cTwo actual installations at 40 and 30% control, respectively

(\$900 to \$2,950 per ton). Oxy-firing and electric boost are the most expensive technologies, with cost-effectiveness values up to \$9,900 per ton.

2.4 IMPACTS OF NO_x CONTROLS

2.4.1 Environmental Impacts

None of the controls shown in Table 2-2 have any solid or wastewater disposal impacts except for the disposal of spent SCR catalyst. Some catalyst formulations are potentially toxic and subject to hazardous waste disposal regulations under RCRA and its amendments. However, recent industry trends have shown that these material are readily regenerable. In fact, many catalyst vendors recycle this material thus avoiding any disposal problem for the user. The control technologies do have impacts on other air pollutants.

2.4.1.1 Combustion Modifications. Combustion modifications in glass furnaces that decrease NO_x may increase emissions of CO and unburned hydrocarbons. For oxy-firing, Table 2-5 shows an increase in SO_x emissions and a decrease in CO and CH₄ (a measure of unburned natural gas) emissions, at least as measured on the basis of lb (of SO_x, etc.) per ton of glass produced.

2.4.1.2 Process Modifications. Cullet preheat can be done using direct or indirect contacting devices to carry out the heat transfer. For direct contact systems, in which the flue gas comes in direct contact with the cullet, there appears to be no net effect on particulates and some reduction of SO_x by adsorption on to the cullet. For indirect control systems, there are no impacts.

2.4.1.3 Postcombustion Modifications.

Selective catalytic reduction. For SCR, the injection of ammonia into the flue gas inevitably results in some unreacted ammonia and some byproducts (e.g., NH₃, Cl₂, (NH₄)₂SO₄) in stack emissions. Such emissions generally increase with time as the catalyst ages. In most SCR applications, unreacted ammonia ("ammonia slip") is kept below 20 to 40 ppm by controlling the injection rate of ammonia. The injection of ammonia may increase stack particulate emissions due to the formation of ammonium sulfate/bisulfate and ammonium chloride, though there is of course a corresponding stoichiometric reduction in gaseous SO_x and HCl emissions.

As with SCR, SNCR generates ammonia slip and byproduct salts from the acidic components of the flue gas. Ammonia slip in one case is reported as 13 ppm. Tests on

TABLE 2-5. EFFECT OF OXY-FIRING ON AIR EMISSIONS

Parameter	Conventional firing (lb/ton glass pulled)	Oxy-firing (lb/ton glass pulled)
Particulate	1.19	0.884
NO _x	5.03	0.812
SO _x	0.612	0.968
CO	0.08	0.003
CH ₄	0.02	0.008

another process show that SNCR

- has no significant effect on total particulate emissions
- slightly increases CO emissions, and
- slightly decreases SO₂ emissions

and ammonia slip (unreacted ammonia emissions) increases with ammonia injection rate. The same general trend would be expected for SNCR processes using urea.

2.4.2 Energy Impacts

2.4.2.1 Combustion Modifications. Data indicate that LEA operation and changes in air/fuel contacting do not significantly affect furnace energy usage (MM Btu/ton glass produced). Based on this, these two combustion modifications are assumed to have negligible energy impacts. For low NO_x burners, the Körtig burner is claimed to result in energy savings by reducing air infiltration, but no quantitative results are presented. Such a claim would be difficult to quantify since air infiltration is highly site specific. Such burners *may* be more efficient than others and would therefore save energy. However, a direct comparison cannot be made with the existing data. Oxy-firing results in lower energy consumption (MM Btu/ton glass produced). This is, in fact, one of the primary reasons for its use. Fuel savings of 15 percent for oxy-firing on a 75 tons/day end-fired regenerative furnace are reported. Production during the test was 58 tons/day. Further, at essentially the same fuel usage rate, glass production increased from 62.7 to 75.8 tons/day (21 percent), as shown below:

	Air-firing	Oxy-firing
Production (tons/day)	62.7	75.8
Fuel usage (MM Btu/hr)	13.7	13.6

This corresponds to 30 to 40 percent energy savings (Figure 2-1) for regenerative glass furnaces, but absolute values (MM Btu/ton glass) are not provided. For the Gallo plant, natural gas usage was 9.5 percent lower than with air-firing (3.74 MM Btu/ton with air-firing, 3.39 MM Btu/ton for oxy-firing).

2.4.2.2 Process Modifications. Cullet preheaters are designed to recover heat from the flue gas and therefore will reduce the energy consumption in glass melting. The

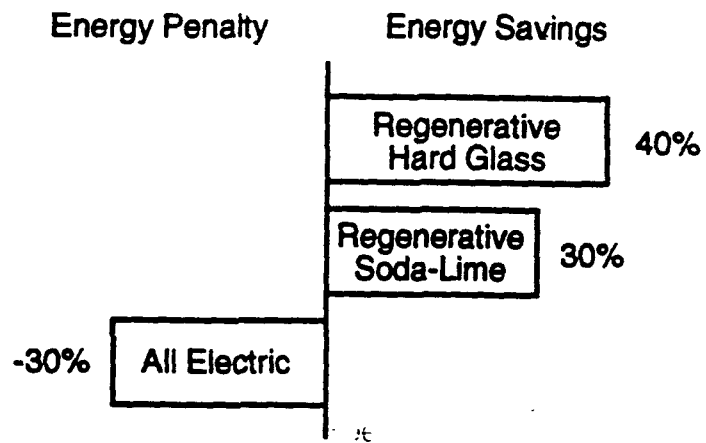

Figure 2-1. Energy impact of oxy-firing.⁶

Teichmann cullet preheater is estimated to account for 8 to 12 percent of the total energy saved by their Low NO_x Melter[®], which also incorporates other energy savings features. Insufficient information is given to determine absolute energy savings associated with the cullet preheater alone.

Electric boost simply substitutes electrical energy for fuel in heating the glass melt. If the efficiency of producing electricity from a fossil fuel and delivering it to the glass melt is taken into account, electric boost is inherently less efficient than natural gas firing and would therefore increase, ultimately, the energy requirement associated with glass melting.

2.4.2.3 Postcombustion Modifications. There is some pressure drop across the SCR catalyst that will require additional electrical energy for the flue gas fan. Typically, this pressure drop is of the order of 5 to 10 in. H₂O. For a pressure drop of 10 in. H₂O, and using a value of 68 scfm per ton/day of glass (see footnote b of Table 5-8) and a fan efficiency of 60 percent, the following calculation can be made:

Plant size (tons/day)	Fan energy (kW)
50	6.6
250	33.2
750	99.4

If the flue gas temperature at this point is below 350 to 500 °C (660 to 930 °F), the gas may need to be reheated with gas burners. This highly site-specific energy impact is not considered further here.

SNCR requires no additional pressure drop for flue gas transport but ammonia or urea are injected in liquid form at high pressure to ensure efficient droplet atomization and dispersion. Liquid ammonia or urea must be vaporized with heat mixed with carrier gas (air or steam) and then injected for adequate mixing.

CHAPTER 3

GLASS MANUFACTURING

3.1 BACKGROUND

Glass is a material made by cooling certain molten compounds in a way in which they do not crystallize. Glass viscosity at ambient temperature is so high that for all practical purposes it is solid. Materials having the ability to cool without crystallizing are rare, silica compounds being the most common.¹ Essentially all glasses of commercial importance are based on silica.

This chapter describes the furnaces associated with the melting and fabrication of container, flat, and pressed/blown glass. Fiberglass is not included. These furnaces carry out certain chemical reactions at extremely high temperatures in a melting furnace. Although the furnace geometry, firing pattern, heat recovery techniques, and specific temperatures vary depending on the type of glass produced, all glass furnaces operate at temperatures where NO_x formation takes place.

3.2 GLASS MAKING

Despite differences in the final products, all glass is manufactured by a process in which the raw materials are mixed and then melted in a furnace. Glass is produced by first mixing dry ingredients in what is known as a batch. In most large furnaces this batch is mixed and fed in a semicontinuous way to one end of the melting furnace. In the melting furnace chemical reactions take place between the batch ingredients. The main reactions can be summarized as follows²:

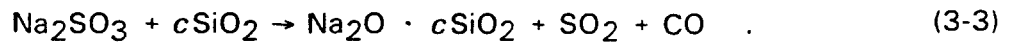
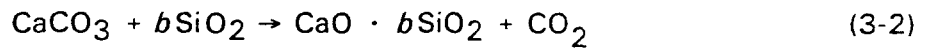
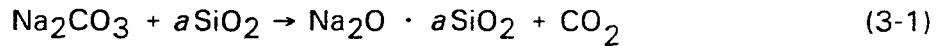

The heat for these reactions is usually supplied by natural gas burners that are fired over the glass melt. Heat is transferred primarily by radiation from the flame to the surface of the melt. The configuration of the furnace is generally end-port or side-port. These are shown in Figures 3-1 and 3-2.³ In the end-port furnaces, the flames travel in a U-shape over the melt from one side and flue gases exit the other. These furnaces are generally used in the container and pressed/blown industries. In the side-port furnaces used in flat and container glass products, the flames travel from one side of the furnace to the other. In both cases, refractory-lined flues are used to recover the energy of the hot flue gas. The high temperature of the flue gas exiting the furnace heats the refractory material called a checker. After the checker has reached a certain temperature, the gas flow is reversed and the firing begins on the other side (or end) of the furnace. The combustion air is then preheated in the hot checker and mixed with the gas to produce the flame. The combustion air preheat temperatures in flat glass furnaces can reach 1260 °C (2300 °F) and substantial NO_x can be formed in the checkers. Lower preheat temperatures are used in container glass, and NO_x contributions in the checkers are apparently negligible.⁴ The cycle of air flow from one checker to the other is reversed about every 15 to 30 minutes in both the end-port and side-port furnaces. The end-port furnaces are smaller than the side-port furnaces. End-port furnaces are generally limited to less than 175 tons/day. The side-port furnaces tend to provide more even heating, which is essential for the high quality necessary for flat glass. Side-port furnaces are also larger, some over 800 tons/day.

Extensive use is made of cullet (broken glass) in both the container and flat glass industries. Cullet may consist of internally recycled glass from waste in downstream operations such as cutting and forming, or it may be externally recycled from glass returned in recycle operations. Because the chemical reactions necessary to form glass have already taken place in the cullet, about half the energy is needed to melt the cullet compared to virgin batch ingredients. Because of the high quality requirements, external

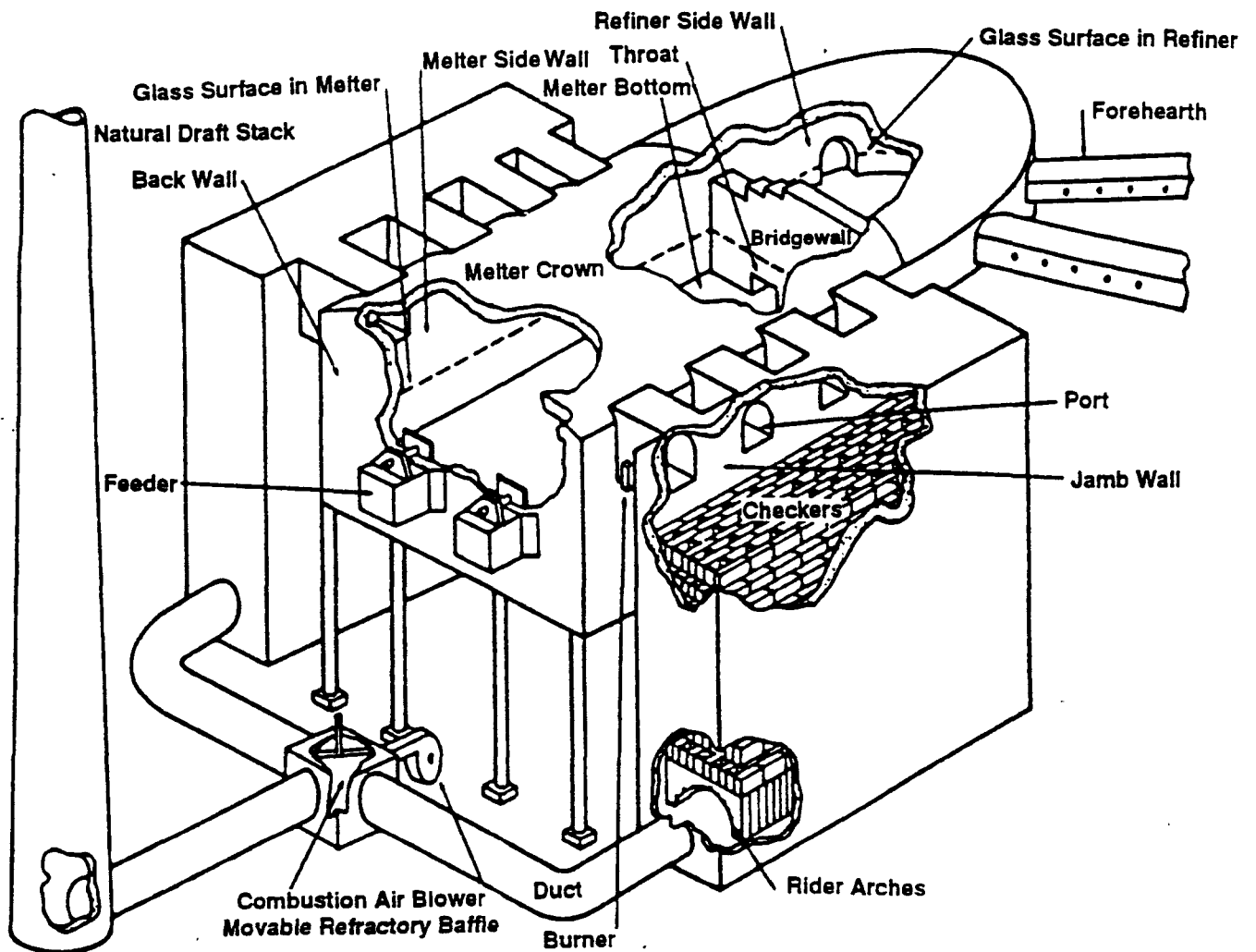

Figure 3-1. Side-port continuous regenerative furnace.³

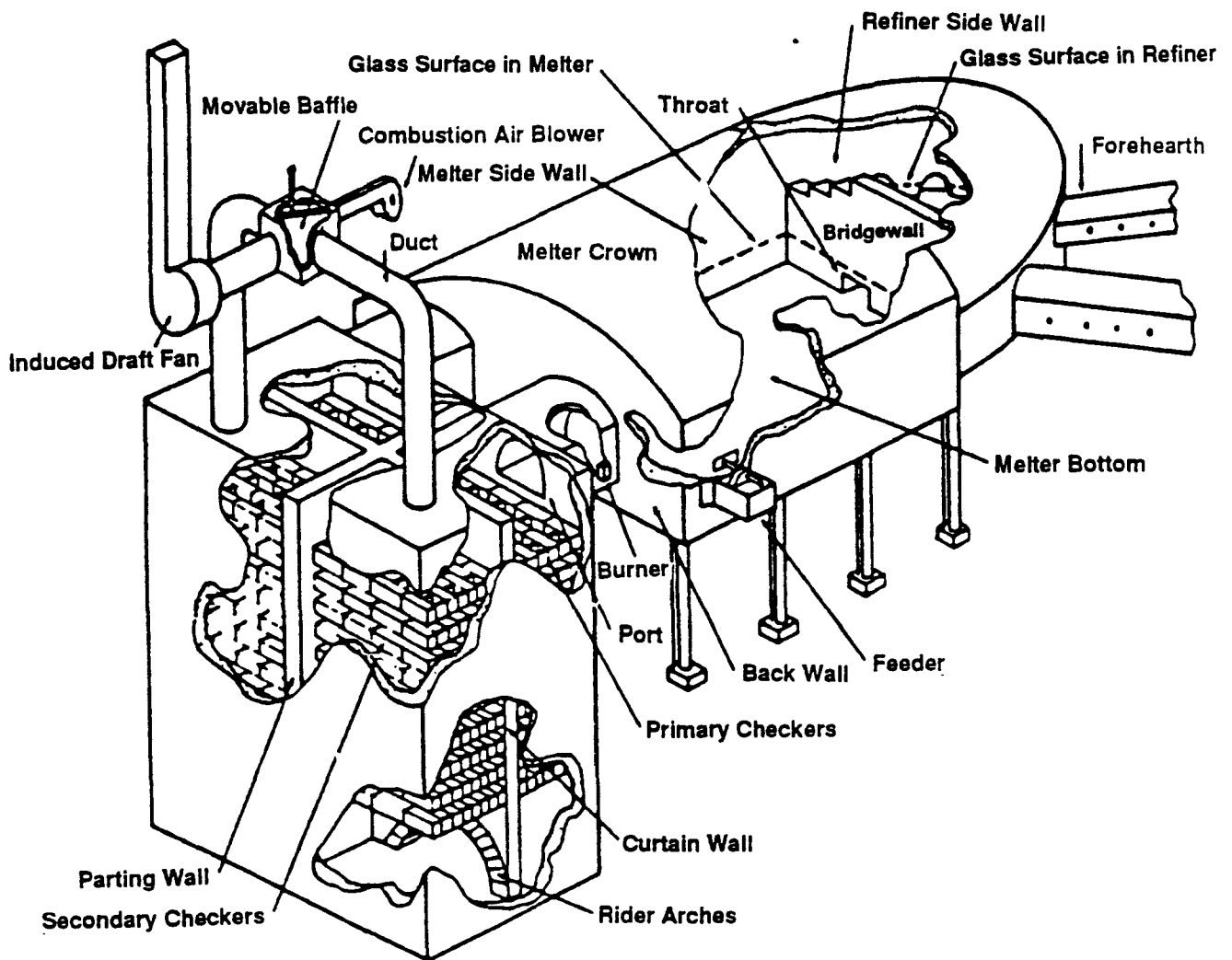

Figure 3-2. End-port continuous regenerative furnace.³

or "foreign" cullet is not used in flat glass production but is used in container glass production.

In the melting chamber, the batch components and cullet react to form glass. Because of heat transfer limitations, a glass melter is generally designed for 0.37 to 0.46 m² (4 to 5 ft²) of melting area/ton of glass produced in a 24-hour day.^{5,6} The depth of the glass melt is usually 1 to 2 m (3 to 6 ft)^{4,5} and is limited by the need to have proper heat transfer and melting of the glass batch. Container glass furnaces are usually 6.1 to 9.2 m (20 to 30 ft) wide and 6.1 to 12.2 m (20 to 40 ft) long.⁴ Flat glass furnaces tend to be longer than those in the container or pressed and blown glass⁶ because of the need to ensure more complete reaction between the batch ingredients and reduce the level of gas bubbles, evolved in reactions (3-1) through (3-3) above, remaining in the finished product.⁷ Typical lengths are over 30.5 m (100 ft).²⁹ As a result, flat glass furnaces typically have a melting capacity of 500-750 ton/day, compared to that of container and pressed/blown furnaces, which are no more than about 600 ton/day. The melt becomes homogeneous and free of bubbles in the "fining" section just downstream of the melting section. Container and pressed/blown glass furnaces generally have the melting and fining (or "refining") section separated by a refractory bridge wall or throat through which the molten glass passes.⁸ The opening between these sections is beneath the surface of the glass. This allows only glass that is free of surface contamination [foam or unmelted batch ingredients, which tend to float or flow to the conditioning section].⁵ Flat glass furnaces do not have a bridge wall.⁶ The opening between the furnace and the downstream refining area is above the surface of the glass in flat glass furnaces.

The production of container, flat, and pressed/blown glass is shown schematically in Figures 3-3 through 3-5.⁹ In principle, the three processes are essentially identical through the melting step,¹⁰ an exception being that pressed/blown glass production does not, as a general rule, use regenerators to recover heat from the flue gas. [This is reflected in the higher energy use in pressed/blown glass production, discussed below.]

In container glass production (Figure 3-3), a typical system downstream of the melter consists of so-called individual section (I-S) machines in which molten glass "gobs" are fed into molds. The containers are then formed by blowing the molten glass into the mold to form the final product. The containers are then carefully cooled in the annealing section to relieve stresses introduced in the molding process. The containers are then inspected in machines to ensure proper dimension, and packed.

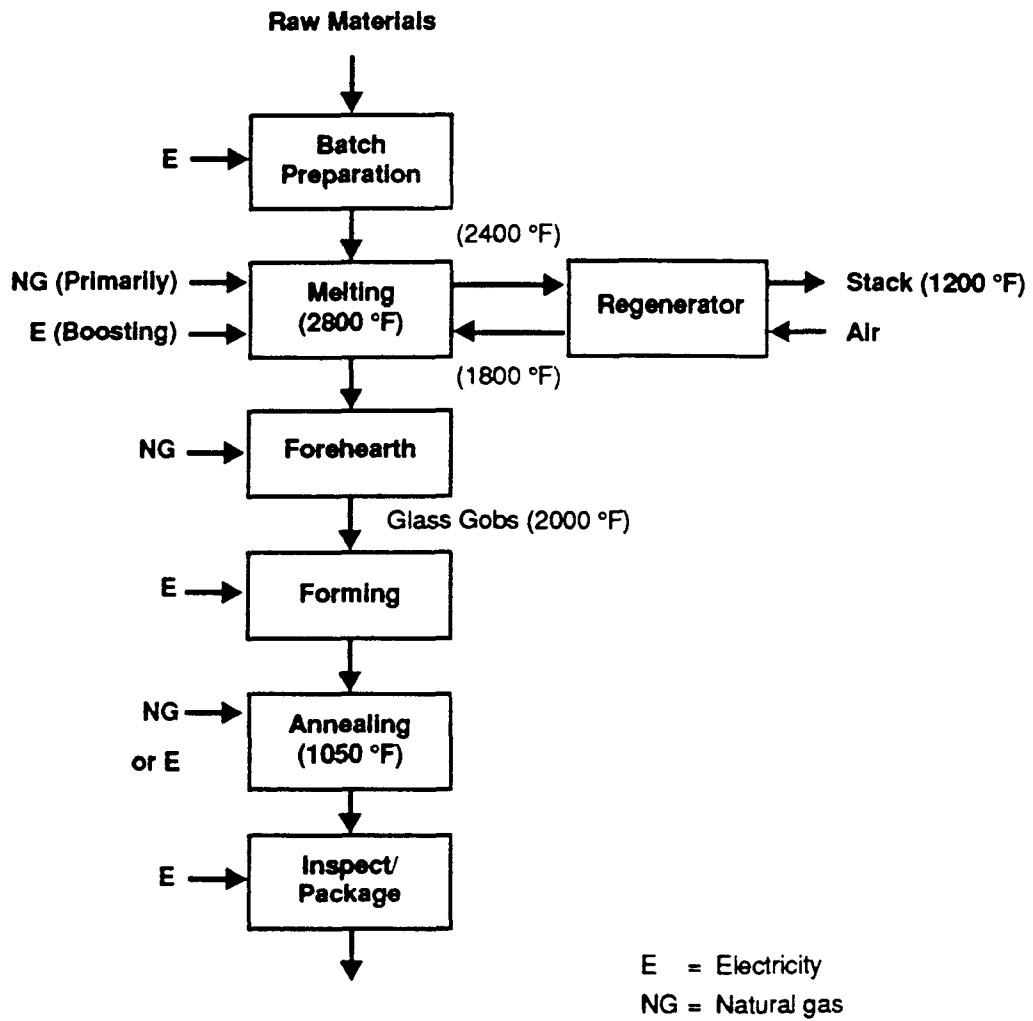

Figure 3-3. Container glass production.⁹

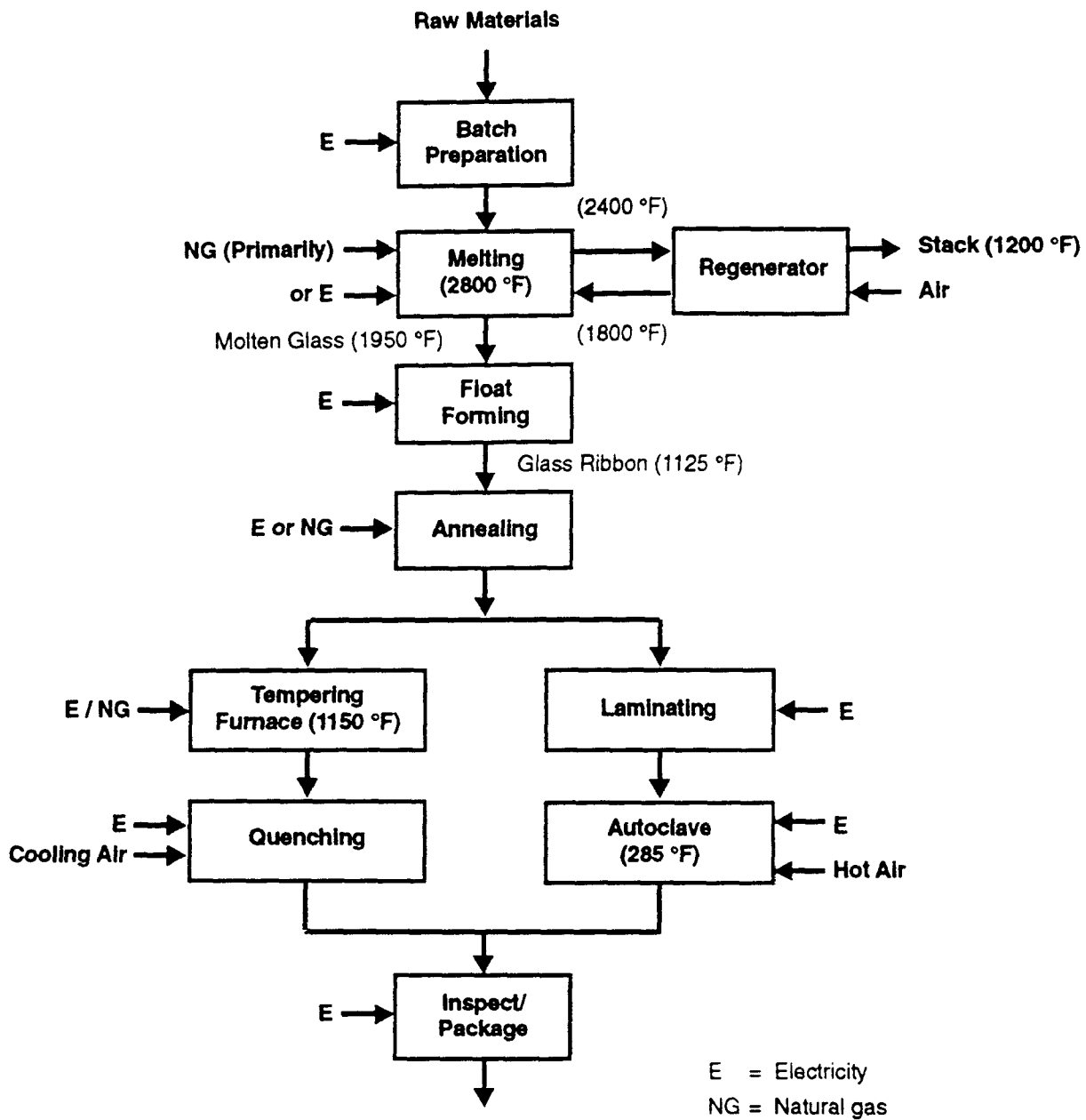

Figure 3-4. Flat glass production.⁹

In flat glass production (Figure 3-4), the molten glass coming from the fining section is poured onto a bath of molten tin through the "canal section." As it flows over this bath, it is gradually cooled from around 1,070 to 610 °C (1,950 to 1,130 °F).⁷ It then enters an annealing section, after which it is cut, packed, and either sold or further processed as shown, generally at a separate facility.

In pressed/blown glass production (Figure 3-5), an extremely wide range of operations can be used downstream of the furnace to produce items such as tableware, light bulbs, glass tubing, and other products. Each of these operations uses vastly different machinery and processes, though each shares the need for controlled heating/forming/cooling steps. Further details are given in Reference 11 and elsewhere.

The glass melting industry is a major consumer of energy. A 1977 study showed that stone, clay, and glass products account for 11 percent of all industrial energy use in the United States.¹² Of the total operating costs in the U.S. glass industry, about 15 percent is for energy, essentially all natural gas. The glass industry consumes about 190 billion ft³ of natural gas/year, about 160 billion of which is for the melting furnace. The theoretical energy requirements for glass can be approximated as follows (per ton of glass produced)¹³:

	<u>10⁶ Btu</u>
Stoichiometric chemical requirements	0.58
Sensible heat of bringing batch to 2,800 °F	<u>1.55</u>
	2.13

Because of the inherently low thermal efficiency of gas-fired regenerative furnaces, about 6 x 10⁶ Btu is required in practice to produce a ton of glass. Of this total, about 40 percent (or about 2.13 x 10⁶ Btu/ton as shown above) goes to heating the batch and for the thermodynamic heat of reactions (3-1) through (3-3) above. About 30 percent is lost through the structure and about 30 percent is lost through the stack.^{4,14} Electric "boosting" of gas-fired furnaces is also practiced in the container and pressed/blown industries, but is not in general use in flat glass furnaces.¹⁵ This consists of placing electrodes at the end of the melting furnace where the batch is introduced and passing a current through the melt to resistively heat the melt. About half of all regenerative furnaces are electrically boosted, with typical boosting being about 10 to 15 percent of the total melting furnace energy needs.^{16,17} Furnace life tends to be shortened by electric

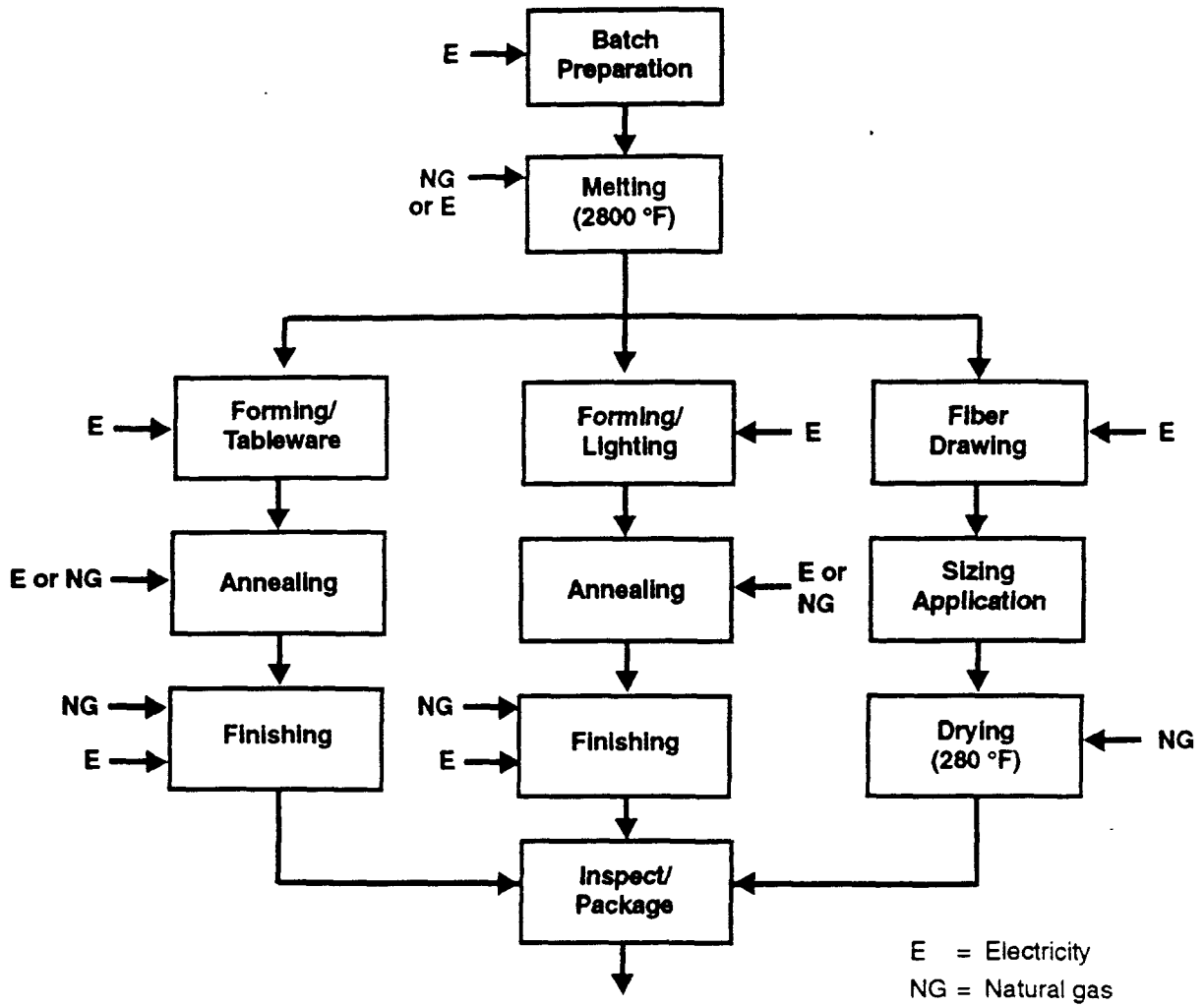

Figure 3-5. Pressed and blown glass production.⁹

boosting.⁴

Glass can also be melted in all-electric furnaces and electric "boost" can be added to gas-fired furnaces. The conversion of electrical energy to useful thermal energy in the glass melt is about 70 to 80 percent, or 2 to 2½ times higher than for gas-fired furnaces. However, the production and delivery of electricity from fossil fuel is only about 30 percent efficient, making all electric furnaces generally uncompetitive. There are other factors that limit the use of electric furnaces including limits to the size of electric furnaces and the electrical conductivity of some batches at high temperature. All electric melters are used in the container business, though most are found in the pressed/blown business.⁵ Electric boost is common in container furnaces. For flat glass furnaces, electric boost has not been demonstrated in furnaces larger than 100 ton/day.

Significant progress has been made in reducing the energy consumption per unit of glass produced in recent years. The increased fuel efficiency has been achieved primarily through the development of advanced refractory materials which helped lower fuel consumption per ton of glass produced in the melting operation by 25 percent in the last 15 years.¹¹ In the flat glass industry, energy consumed per unit of glass produced declined from 23 million Btu/ton to 13 million Btu/ton in the period 1976 to 1986.¹⁸ Energy used in the pressed/blown glass segment decreased from 29 million Btu/ton in 1977 to 20 million Btu/ton in 1985. Fuel use for melting operations in the three industries considered here is as follows¹⁹:

<u>Industry</u>	<u>Total energy consumed for melting (10⁶ Btu/ton)</u>
Container	8-10
Flat	6-7
Pressed/blown	16

The higher energy consumption in the pressed/blown glass industry reflects the inherent inefficiencies of the small-scale furnaces characteristic of much of this industry. The high value-added and the high labor costs due to less automation in this sector make energy efficiency less important than in the container and flat glass sectors.

3.3 OVERVIEW OF THE GLASS-MAKING INDUSTRY

A 1984 study reported 800 glass melting furnaces in the United States.²⁰ Many of these are either for fiberglass (not considered here) or are small furnaces for specialty and art glass. There are a much smaller number of continuous, industrial-scale furnaces which are of interest here. Figure 3-6 shows the location of container, flat, and major pressed/blown plants in the United States.²¹ Table 3-1 shows the distribution of glass production among the three industries considered here in 1988.¹¹

Despite the general similarities in the glass melting operations in the three segments of the glass manufacturing business considered here, the three industries are substantially different. The container glass industry, accounting for over 50 percent of all glass produced in the United States, generally uses smaller furnaces with lower temperatures and different raw materials than the flat glass industry. The pressed/blown segment of the glass business generally uses smaller furnaces than those used for either the container or flat glass and is generally a more widely dispersed industry.²⁵ These three segments of the glass-making industry are considered separately. The composition of the glass and the quality specifications are also somewhat different. The flat glass industry has the highest quality requirements, leading to special care in the melting operation as well as downstream annealing processes.

TABLE 3-1. GLASS PRODUCTION IN 1988

Industry	Glass production (10 ⁶ of tons)	Percent of production
Container	10.1 ^a	53
Flat	4.1 ^a	22
Pressed/blown	4.7 ^b	25
Total	18.9^c	100

^aAs of 1988.

^bCalculated based on 25% of total production.²³

^cMcGraw-Hill Encyclopedia of Science and Technology reports about 20 million tons are produced "each year" in the United States.²⁴

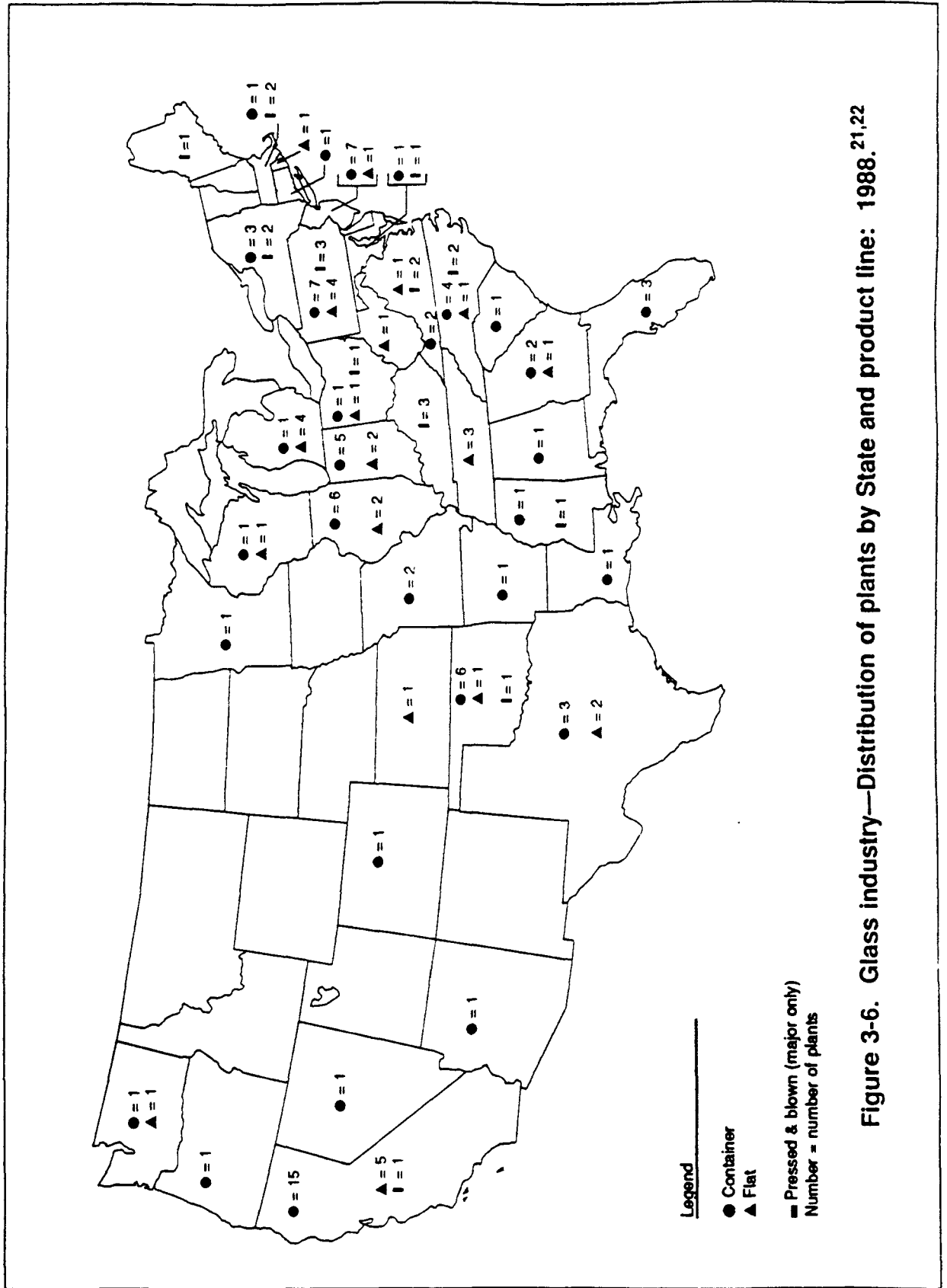

Figure 3-6. Glass industry—Distribution of plants by State and product line: 1988. 21,22

3.3.1 Container Glass

Container glass is used primarily for alcoholic and nonalcoholic beverages and food. The container glass industry has been affected by major restructuring in recent years. Two companies now account for over 60 percent of the operating capacity, and four account for over 80 percent (Table 3-2). These four major companies are Anchor Glass, Ball-Incon Glass Packaging, Owens-Brockway, and Triangle Industries.²⁶ One projection showed that total glass production for containers will decrease by about 10 percent by 1995.²⁷ This is the result of competition from aluminum and plastic containers in the beverage business. Figure 3-7 shows the geographic distribution of the 194 furnaces and 83 plant locations in the container glass industry in 1988.²⁸ Melting furnaces are of the order of 100 to 300 ton/day.

3.3.2 Flat Glass

Flat glass consists almost exclusively of architectural and automotive glass. It is generally of higher quality than container or pressed/blown glass. Melting is carried out in large (400 to 800 tons/day) furnaces. Table 3-3 shows the principal U.S. flat glass companies, which account for essentially all flat glass production.¹¹

3.3.3 Pressed/Blown Glass

Pressed/blown glass consists of tableware, lighting/electronic, and scientific products. A large fraction of this industry consists of owner-managed, small, hand-operated manufacturing operations with furnace capacities of 5 to 25 tons/day, some of which are electric.²⁹ However, some larger operations use gas-fired furnaces on the order of 100 to 200 tons/day. The production process is shown schematically in Figure 3-5. The principal U.S. companies are shown in Table 3-4.

TABLE 3-2. PRINCIPAL FEATURES OF MAJOR COMPANIES IN THE CONTAINER SEGMENT^{4,11}

Company	Ownership	Estimated total sales (MM \$)	Estimated glass container sales (MM \$)	Other product lines	Approximate capacity (tons per day)	Estimated market share (%)
Owens-Brockway	Public	4,800	1,600	Specialty glasses and plastic containers; forestry products; health and financial services	13,900	35
Anchor Glass Container	Public	1,230	1,200	Plastic and metal closures	9,700	25
Ball-Incon Glass Packaging	Thyssen and Ball joint venture	7,200	550	Plastic and paper containers	4,800	12
Triangle	Public (CJI)	3,800	500	Metal and plastic containers, fabricated metal products	3,800	9

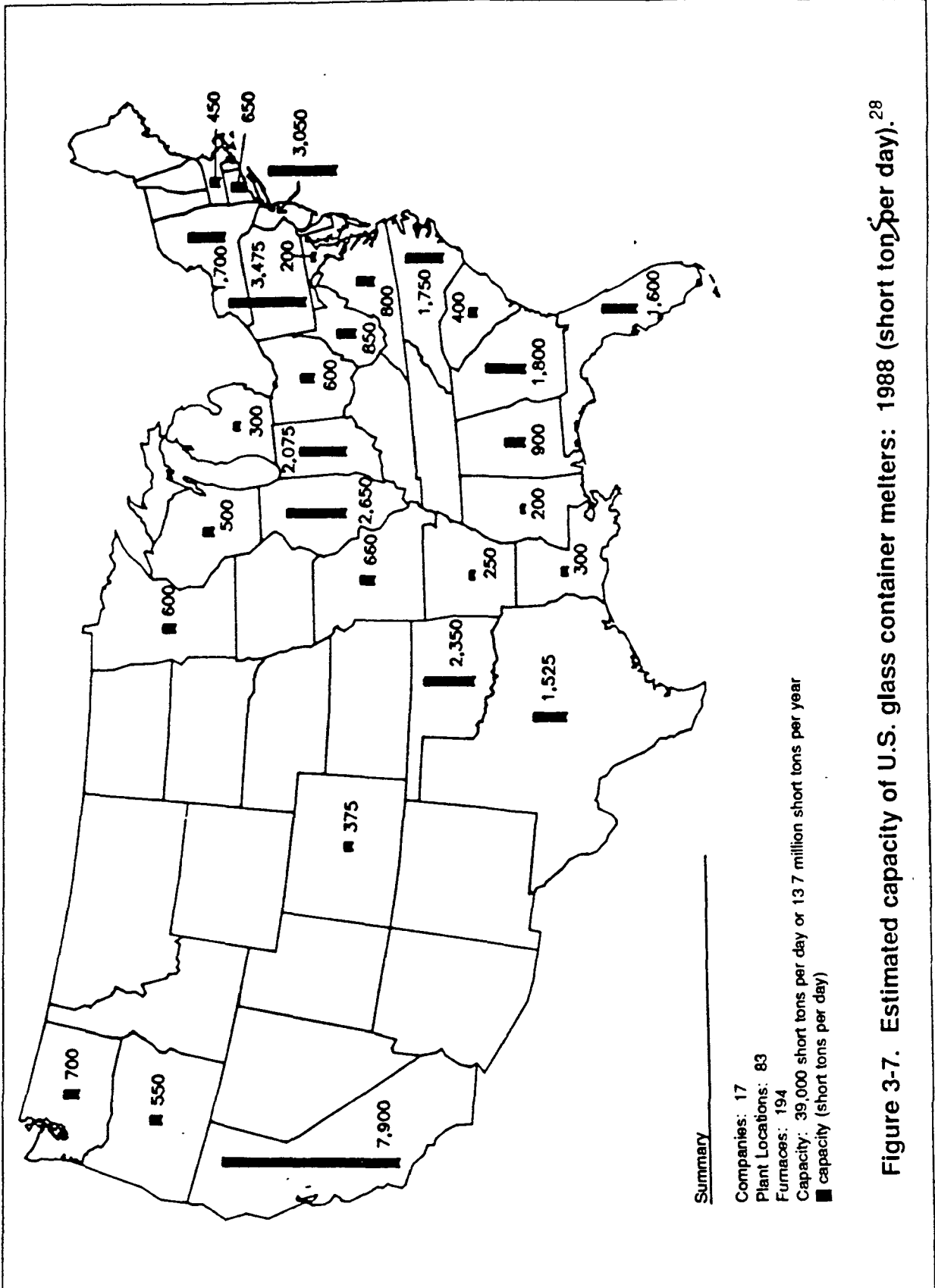

Figure 3-7. Estimated capacity of U.S. glass container melters: 1988 (short ton per day).²⁸

TABLE 3-3. PRINCIPAL U.S. COMPANIES PRODUCING FLAT GLASS^{11,22}

Company	Ownership	Estimated sales (MM \$)	Estimated production capacity (MM short tons/year)
AFG Industries	Public	450 ^a	0.50
PPG Industries	Public	4,687 ^b 2,058 ^a	1.40
Ford Motor	Public	300 ^a	0.35
Libby-Owens-Ford	Pilkington (U.K.)	900	0.77
Guardian Industries	Private	600 ^a	0.50

^aGlass sales.

^bTotal sales.

TABLE 3-4. PRINCIPAL U.S. COMPANIES PRODUCING PRESSED AND BLOWN GLASS TABLEWARE AND KITCHENWARE¹¹

Company	Ownership	Estimated annual sales (MM \$)	Principal products	Other products
Anchor Hocking	Public	758	Table glassware	Cosmetic containers at Carr-Lowrey Div., microwaveable ovenware lighting products at Phoenix Glass, hardware and china
Corning Glass	Public	1,860	"Pyrex" ovenware and dinnerware	Laboratory ware, industrial glass, bulbs, lamps, TV tubes, etc.
Indiana Glass Company	Lancaster Colony Corp.	a	Hotel and restaurant glass tableware	None
Lenox Crystal	Lenox, Inc.	b	Stemware	
Libbey Glass ^d Division	Owens-Illinois	c	Glass stemware, tumblers, tableware	Glass containers, health and financial services
St. George Crystal	Private	10	Stemware, tumblers	

^aSales not known. Employees: ca. 600.

^bSales not known. Employees: ca. 300.

^cSales not known. Employees: less than 100.

^dLibbey Glass is an independent subsidiary of Owens-Illinois.⁴

3.4 REFERENCES

1. McGraw-Hill Encyclopedia of Science and Technology. 6th ed. New York. McGraw-Hill. v. 8. p. 125. 1987.
2. Austin, G.T. Shreve's Chemical Process Industries. 5th ed. New York. McGraw Hill. 1984. p. 198.
3. U.S. Environmental Protection Agency. Compilation of Air Pollutant Emission Factors, Vol. 1: Stationary Point and Area Sources. Research Triangle Park, NC. Publication No. AP42 (GPA 055-000-00251-7). 4th ed. (including supplements A, B, C, and D). September 1991.
4. Glass Packaging Institute, Washington, DC, letter to W.J. Neuffer, EPA/OAQPS, April 8, 1993.
5. Charles River Associates. Glass Industry: Opportunities for Natural Gas Technologies. Gas Research Institute. Chicago, IL. Topical Report No. GRI-88/0266. September 1988. p. 10.
6. Kirk Othmer Encyclopedia of Chemical Technology. John Wiley. 3rd ed. 1981. v. 13. p. 852.
7. Ref. 5, p. 47.
8. Ref. 6, pp. 851-852.
9. Charles River Associates. Adapted from Garrett-Price, B.A., et al. Potential for Energy Conservation in the Glass Industry. U.S. Department of Energy. Report PNL-5640/UC95f. June 1986. 1987.
10. Ref. 5, p. 5.
11. Ref. 5, pp. 73-82.
12. Kusik, C.L., J.I. Stevens, R.M. Nadkarni, P.A. Huska, and D.W. Lee. Energy Use and Air Pollution Control in New Process Technology. Chemical Eng. Prog. p. 36. August 1977.
13. Ref. 5, p. 13.
14. Ref. 6, p. 856.
15. Memo from Spivey, J.J., RTI to Neuffer, W.J., EPA/OAQPS, August 5, 1993. Minutes of July 20, 1993, meeting between Primary Glass Manufacturing Council and EPA/OAQPS.
16. Ref. 6, p. 853.

17. Rindone, G.E., J.R. Hellman, and R.E. Tressler. An Assessment of Opportunities for Gas-Fired Boosting of Glassmelting Process. Gas Research Institute. Chicago, IL. Topical Report No. GRI-89/0254. January 1990. p. 1.
18. Ref. 5, pp. 50-51.
19. Ref. 5, pp. 86, 88, 93.
20. Strumpf, H., D. Kotchick, and M. Coombs. High-Temperature Ceramic Recuperator and Combustion Air Burner Program. Gas Research Institute. Chicago, IL. Topical Report No. GRI-83/0039. February 1986.
21. Ref. 5, p. 26.
22. Letter and attachments from Benney, J.C., Primary Glass Manufacturing Council, Topeka, KS, Neuffer, W.J., EPA/OAQPS, April 22, 1993, 10 pp., comments on draft ACT report.
23. Ref. 3, p. 8-13-1.
24. Ref. 1, p. 1.
25. Ref. 5, p. 1.
26. Ref. 1, p. 24.
27. Ref. 5, p. 43.
28. Ref. 5, p. 45.
29. Ref. 1, p. 74.

CHAPTER 4
CHARACTERIZATION OF NO_x EMISSIONS

4.1 NO_x FORMATION

NO_x is formed in glass melting furnaces by:

- the homogeneous gas phase reaction of N₂ and O₂ in the combustion air, producing primarily NO,
- the evolution of NO₂ from nitrate compounds used in certain glass formulations, and
- oxidation of fuel-bound nitrogen.

[The term "NO_x" can refer to any of six nitrogen-oxygen compounds^{1,2}; only NO and NO₂ are of interest and together are referred to as NO_x herein.] At conditions of practical interest, about 95 percent of the NO_x in the flue gas is NO.³ The term NO_x is thus often used to refer to only the NO in the flue gas.

4.1.1 Homogeneous NO_x Formation

The homogeneous gas phase reaction of N₂ and O₂ in air is generally thought to proceed through a mechanism first formulated by Zeldovich.⁴ This is often called thermal NO_x. The two most important steps in this mechanism are

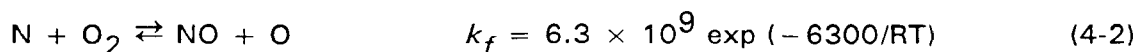
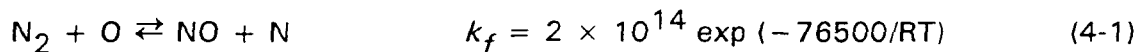

where k_f are the forward rate constants for the reactions shown. The high activation energy of Reaction (4-1), 76.5 kcal/mol, means that this reaction is the most temperature sensitive.

The equilibrium constant for Reaction (4-3) depends, of course, only on the temperature. However, the equilibrium *concentrations* of NO_x (NO and NO₂) also depend on the concentrations of N₂ and O₂ in the gas. Table 4-1 shows the *equilibrium* concentrations of NO and NO₂ (NO₂ is generated by reaction of NO with O₂) for two

TABLE 4.1. CALCULATED EQUILIBRIUM CONCENTRATIONS OF NO AND NO₂ IN AIR AND FLUE GAS (ppm)⁵

Temperature		Air		Flue Gas	
K	°F	NO	NO ₂	NO	NO ₂
300	80	3.4(10) ⁻¹⁰	2.1(10) ⁻⁴	1.1(10) ⁻¹⁰	3.3(10) ⁻³
800	980	2.3	0.7	0.8	0.1
1,400	2,060	800	5.6	250	0.9
1,870	2,910	6,100	12	2,000	1.8

conditions.⁵ First, the equilibrium NO and NO₂ concentrations for N₂ and O₂ concentrations found in ambient air are shown. These are important for glass melters because the combustion air is often preheated to temperatures above 1090 °C (2,000 °F),⁶ which Table 4-1 shows would result in the formation of about 800 ppm NO and 6 ppm NO₂ at *equilibrium*. Second, Table 4-1 also shows the NO and NO₂ concentrations at flue gas conditions, where the O₂ and N₂ concentrations are defined, for this table, as 3.3 percent O₂, 76 percent N₂. In this case, the *equilibrium* NO_x concentrations are lower because of the lower O₂ concentration. For glass melting, this situation would correspond to the flue gas from the melting furnace, whose temperature would be around 538 °C (1,000 °F). At this flue gas temperature, the equilibrium NO concentration is around 1 ppm with NO₂ being about 0.1 ppm.

In practice, of course, glass furnace flue gas NO_x concentrations are much higher than this, typically around 1,000 ppm NO. The reason is the high activation energy of Reaction (4-1), which is generally thought to be rate controlling. After the NO is formed in the high temperatures of the flame (which can reach well above 1650 °C (3,000 °F)), the rate of its decomposition [the reverse of Reactions (4-1) and (4-2)] is kinetically limited at the lower temperatures and lower O and N atom concentrations in the post-combustion zone of the flame. Thus, although NO_x is thermodynamically unstable even at the high temperatures of the glass furnace flue gas, its decomposition is kinetically limited. The result is that the NO_x concentration in the flue gas is higher than predicted by equilibrium and depends, to a large degree, on the mixing of the fuel and combustion air in the flame. Techniques to minimize NO_x formation by modification of these conditions are discussed in Chapter 5. The following empirical expression describes, at least qualitatively, the effects

Chapter 5. The following empirical expression describes, at least qualitatively, the effects of temperature, time (of the gases in the flame zone), and N_2/O_2 concentrations on NO levels in the outlet gas of a combustion process⁷:

$$C_{NO} = 5 \times 10^{17} [\exp(-72,300/T)] y_{N_2} y_{O_2}^{1/2} t \quad (4-4)$$

where

- C_{NO} = NO concentration, ppm,
- y_i = mole fraction of gas i ($i = N_2, O_2$),
- T = absolute temperature, K, and
- t = time, seconds.

Effects of fuel type, flame geometry, and other factors that can significantly affect NO generation are not accounted for in this expression. Thus, absolute NO concentration from any specific furnace cannot necessarily be predicted using this expression. The time in the flame zone is about 0.5 seconds.⁸ For an adiabatic flame temperature for natural gas at 10 percent excess air of 1,870 °C (3,400 °F), and using $y_{N_2} = 0.79$ and $y_{O_2} = 0.21$ (the N_2 and O_2 present in ambient air), Equation (4-4) predicts C_{NO} to be 206 ppm, which may be an underestimate.⁹ Nevertheless, the essential features of this equation—exponential dependence of NO concentration on temperature, half-order dependence on O_2 concentration, and linear dependence on N_2 concentration and time—provide qualitative guidance on the *effect* of time, temperature, and excess air on NO emissions at conditions of practical interest.

Figure 4-1 shows the generation of NO_x as a function of excess air.¹⁰ The importance of this plot for glass melters (and other operations) is that fuel firing rates are often given in millions of Btu/hr (MM Btu/hr). Knowing the furnace temperature and excess air, the lb NO_x /MM Btu can be determined (e.g., about 1.5 lb NO_x /MM Btu from Figure 4-1 for 1370 °C (2,500 °F) and 40 percent excess air). This can then be multiplied by the firing rate (MM Btu/hr) to give an NO_x generation rate (lb NO_x /hr). Thermal NO_x emissions, in turn, vary directly and linearly with fuel firing rate, all other conditions being equal.¹¹

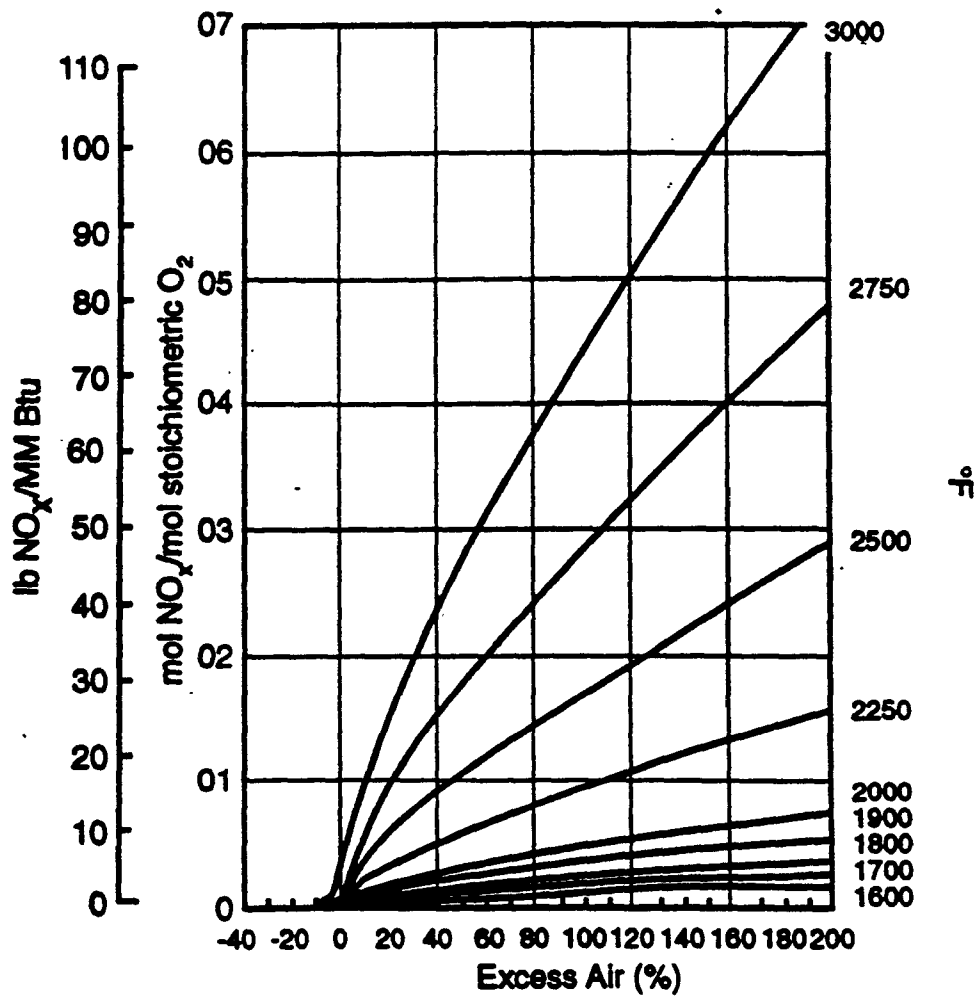

Figure 4-1. Generation of NO_x¹⁰

4.1.2 NO_x from Nitrates

NO₂ is formed when sodium and potassium nitrates, called "niter," are used in certain glass batch formulations. The purpose of these compounds is to aid in the removal of bubbles from the melt in the "fining" section of the melting furnace. These materials react at higher temperatures than needed for melting so that the removal of bubbles continues after the melting reactions are complete.¹² Though some niter is used in flat glass production, most is used in container and pressed/blown glass.

The evolution of NO₂ from the nitrates is essentially stoichiometric, i.e., all NO₂ present in the nitrate is released in the furnace. Thus the amount of NO₂ released depends on the niter content of the batch.

4.1.3 NO_x from Fuel/Oxidizer

NO_x can also be produced by oxidation of fuel-bound nitrogen, e.g., pyridines or other organonitrogen compounds. Air infiltration may also be a source of nitrogen. Natural gas is the fuel used predominantly in glass melters. Though natural gas, as delivered to the burner from the pipeline, may contain as much as 1 to 3 percent N₂, it has essentially no fuel-bound nitrogen. Many plants have backup fuel capability for emergencies,¹³ which is regarded as essential given the high cost of startup once a fuel interruption occurs. Typical fuels include LPG, No. 2 fuel oil, and diesel. However, there are no data at present to assess the proportion of glass melters using fuels other than natural gas, nor the proportion of time other fuels might be used even in furnaces usually using natural gas.

Nitrogen is also present even when "oxygen" is used in oxy-firing (Section 5.2.3). Depending on the source of oxygen, nitrogen levels can be 100 ppm to several percent. This nitrogen, plus nitrogen from the inevitable air infiltration, is also a potential source of NO_x in oxy-firing.

4.2 FACTORS AFFECTING NO_x EMISSIONS

NO_x emissions can be measured in two ways. The first is the *rate* of NO_x generation, e.g., in units of lb NO_x/hr at a given fuel firing rate, or ppm of NO_x at a given flue gas volumetric flow rate, typically corrected to a specific O₂ level (e.g., 3% O₂). The second is the amount of NO_x produced per ton of production, e.g., lb NO_x/ton glass produced.

4.2.1 NO_x Generation Rate

Essentially all of the NO_x produced in a flame is generated at the peak flame temperature. The following factors, measured at this temperature, have the greatest effect on the *rate* of NO_x generation:

- N₂ concentration,
- O₂ concentration,
- temperature, and
- gas residence time.

If air is used in the combustion process, the nitrogen concentration in the furnace is essentially constant. The oxygen concentration, however, will decrease as fuel is consumed. It is the local concentration of oxygen in that part of the flame where the peak temperature occurs that affects NO_x generation. For this reason, many of the low-NO_x burners discussed in Chapter 5 limit NO_x generation by staging the combustion, in effect limiting the oxygen concentration while lowering the peak flame temperature. Note, however, that Equation (4-1) shows that the NO concentration is only half-order in oxygen concentration, meaning that decreasing the oxygen concentration by, say, one-half, only decreases the NO concentration by 29 percent ($0.5^{1/2} = 0.71$).

The peak flame temperature is the most important factor affecting NO_x generation, as shown by Equation (4-4). The adiabatic flame temperature, which is the temperature reached by a given proportion of fuel and combustion gas (e.g., air), can be calculated from thermodynamic data. This is the maximum temperature that can be achieved in a flame with that fuel. It is a function of the air/fuel ratio, which is in turn often expressed as the equivalence ratio of Figure 4-2 [equivalence ratio = $\phi = (\text{air/fuel})_{\text{actual}}/(\text{air/fuel})_{\text{stoichiometric}}$]. For $\phi < 1$, the combustion mixture is fuel-rich; for $\phi > 1$, the mixture is fuel lean. Figure 4-2 shows such a plot for various fuels.⁹ [This plot is for an initial pressure of 10 atm and is not, therefore, numerically valid for combustion at 1 atm. However, adiabatic flame temperature is not a strong function of pressure (see Reference 14) and the qualitative trends, e.g., adiabatic flame temperature as a function of equivalence ratio and fuel type, are valid. For natural gas, which contains mostly methane (with some ethane and propane) the peak flame temperature at the 10 to 20 percent excess air used in glass melters is around 1,820 °C (3,300 °F). In practice, the peak flame temperature will be somewhat less since heat is transferred (by radiation)

from the flame to the glass melt. Figure 4-2 shows that the peak flame temperature can be lowered by either fuel-rich ($\phi < 1$) or fuel-lean ($\phi > 1$) conditions. Practical considerations, such as emissions of unburnt hydrocarbons at fuel-rich conditions and lower heat generation rate (MM Btu of heat generated from a given quantity of fuel) at fuel-lean conditions, as well as less than ideal gas/fuel mixing, lead to operation of glass melters at $\phi \approx 1.1$ or so. Figure 4-3 shows NO_x concentrations measured in the combustion zone for glass furnaces as a function of air/fuel ratio.¹⁵ [Air/fuel ratio is proportional to equivalence ratio; an equivalence ratio of 1.0 corresponds to an air/fuel ratio of 9.52.]

In some furnaces, the peak flame temperature may vary with furnace position. This is because multiple firing ports are often used to develop the temperature needed to melt the glass and react the ingredients at specific points in the furnace. For example, higher temperatures may be needed at the furnace entrance because raw materials are added there. This distribution of fuel can cause higher overall NO_x emissions than an even distribution would because of the exponential dependence of NO_x emissions on peak flame temperature.

The final factor affecting the NO_x generation rate is gas residence time, i.e., the time the fuel/combustion gas mixture remains at the peak flame temperature. As with oxygen concentration, a great number of burner designs have been developed to minimize NO_x generation by minimizing this parameter. Because Equation (4-1) suggests that NO concentration is linear in gas residence time, decreasing it has a numerically greater effect than decreasing O_2 concentration. However, in practice there are narrow limits to gas residence time within which a stable flame can be produced. Typical gas residence times at conditions of practical interest are of the order of 0.1 to 0.5 seconds.

The temperatures and residence times required for NO_x formation are also present in the air preheating used on regenerative furnaces (Figures 3-1 and 3-2). Air preheat temperatures may exceed 1,260 °C (2,300 °F) and residence times are of the order of seconds. Together, these can lead to formation of NO_x in the preheated air.

4.2.2 Normalized NO_x Emissions

NO_x emissions are often expressed by the rate of production of glass; e.g., regulations in the South Coast Air Quality Management District (SCAQMD) are written in units of lb NO_x /ton glass produced. Overall NO_x emissions, by this measure, can thus be decreased by increasing the productivity of the furnace (ton glass produced per hour) even

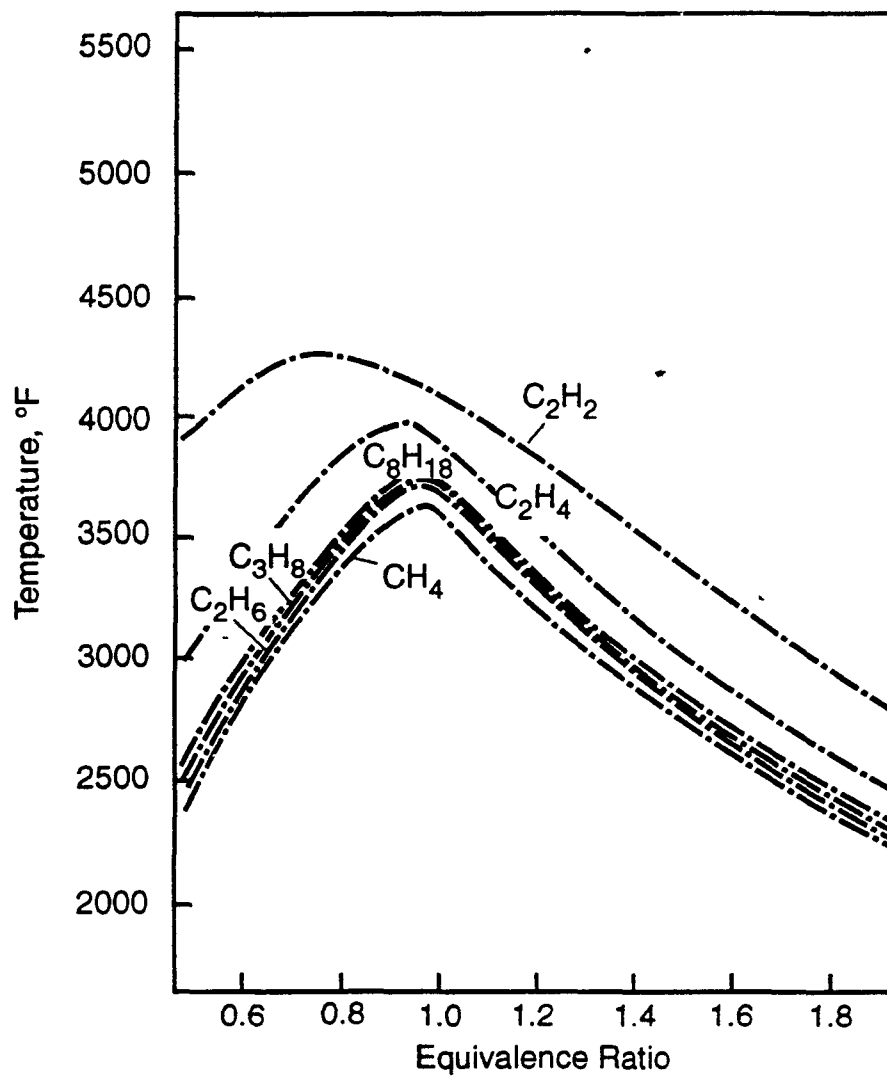

Figure 4-2. Relationship between equivalence ratio and adiabatic flame temperature.⁹

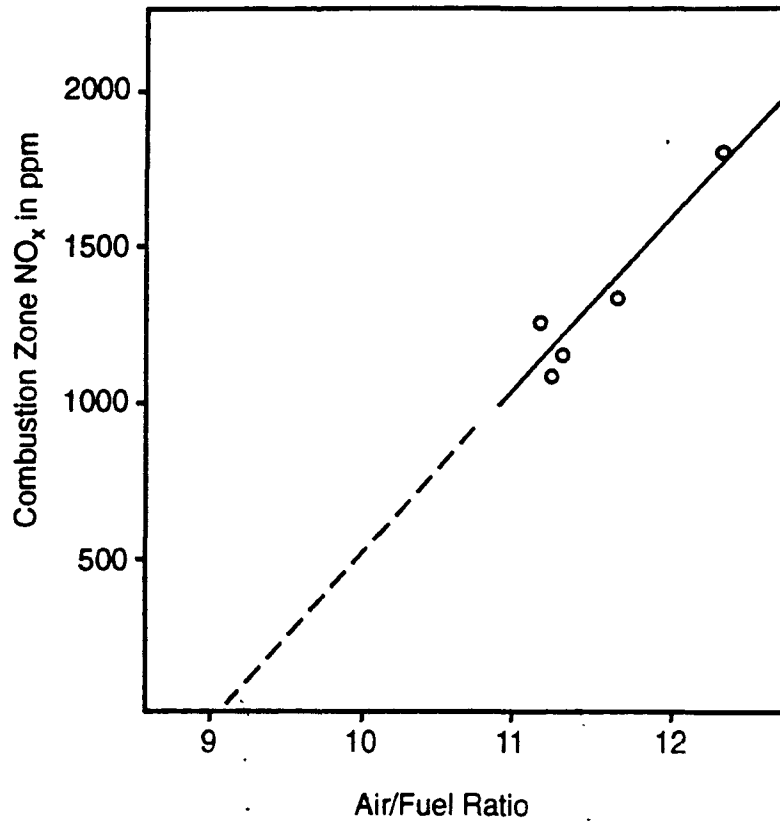

Figure 4-3. Relationship between air/fuel ratio for natural gas fuel and NO_x concentration normalized to combustion zone conditions.¹⁵

if the *rate* of NO_x generation (lb NO_x/hr) is constant. Factors affecting these normalized NO_x emissions, then, can include better refractory insulation (meaning that less heat is lost through the refractories) and process changes such as oxy-firing. These control techniques are discussed in Chapter 5.

4.3 UNCONTROLLED NO_x EMISSIONS

Table 4-2 summarizes NO_x emissions reported from glass melting furnaces. These values range from 2.5 to 27.2 lb NO_x/ton of glass produced. This wide range reflects the variation in site-specific factors that affect uncontrolled NO_x emissions.

These include furnace size (smaller furnaces tend to have higher normalized NO_x emissions than larger furnaces), furnace age, air infiltration, burner geometry, combustion air preheat, and other factors. The NO_x *concentration* in the flue gas is also important. As a general rule, thermal NO_x concentrations (i.e., exclusive of NO₂ from niter) are in the range of 1,000 to 3,000 ppm, depending on burner design, fuel firing rate, and other parameters.^{6,28}

For the purpose of calculating the effect of the control technologies on NO_x emissions, uncontrolled NO_x emissions are defined as follows:

<u>Furnace type</u>	Uncontrolled NO _x emissions, <u>lb NO_x/ton</u>
Container glass	10.0
Flat glass	15.8 ²⁶
Pressed/blown glass	22.0

These values approximate uncontrolled levels of a wide range of regenerative furnaces.²⁹⁻

³¹ Based on the information in Table 5-9, NO_x emissions reductions are shown in Table 5-10. NO_x reductions based on these uncontrolled levels are used in calculating cost effectiveness in Chapter 6. Assuming a heat input of 6 MM Btu/ton (from Chapter 3), these values correspond to uncontrolled emissions of 1.67, 2.63, and 3.67 lb NO_x/MM Btu, respectively, for container, flat, and pressed/blown glass furnaces. It is important to look at both measures of NO_x emissions - lb/ton glass and lb/MM Btu. These two measures are, of course, related by the heat input, measured in units of MM Btu/ton of glass, which is, in turn, a measure of the thermal efficiency of the glass furnace. Except for oxy-firing, the two measures of NO_x controlled emissions in Table 5-9 are

TABLE 4-2. UNCONTROLLED NO_x EMISSIONS

Company (plant location)	Type of glass produced	Design capacity (ton/day)	Type of furnace	Uncontrolled NO _x emissions (lb/ton)	Reference(s)
Container					
Gallo Glass (Modesto, CA)	Wine bottles	400	Side-port	5.19	16-18
Carr Lowrey (Baltimore, MD)	Drug, food, cosmetic bottles	75	End-port	21.6 ^a	19, 20
Latchford Glass (Los Angeles, CA)	NR Amber containers	530 140-165	NR End-port	8.9 ^b 7-8	23 24, 25
Diamond Bathurst	Flint container glass	250	Side-port	12	24, 25
American National Can	Containers	161-458 ^c	NR	2.5-10.9 ^c	Section 114-American National Can
Anchor Glass	Containers	137-624 ^d	NR	2.7-21 ^d	Section 114-Anchor Glass
Owens-Brockway	Containers	177-500 ^e	NR	1.8-20.5 ^e	Section 114-Owens Brockway
Flat					
PPG (Fresno, CA)	Flat glass	500	Side-port	22.3 - 23.6	Section 114-PPG
(Mt. Zion, IL)	Flat glass	750	NR	10.7 - 14.0	Section 114-PPG
AFG (Spring Hill, KS)	Flat glass	552	NR	8.8	Section 114-AFG
(Church Hill, TN)	Flat glass	552	NR	17.8	Section 114-AFG
#2 furnace (Victorville, CA)	Flat glass	552	NR	13.0-15.2	Section 114-AFG
NR	Flat glass	NR	NR	8.7-25.8 ^h	26
Ford Motor (Tulsa, OK)	Flat glass	NR	Side-port	11.8 - 15.4	Section 114 - Ford
2 furnaces					
LOF					
(Lathrop, CA)	Flat glass	NR	Side-port	9.8 - 13.2	Section 114-LOF
(Laurinburg, NC) #1	Flat glass	NR	Side-port	10.4 - 20.3	Section 114-LOF
(Laurinburg, NC) #2	Flat glass	NR	Side-port	13.8 - 17.2	Section 114-LOF
(Ottawa, IL)	Flat glass	NR	Side-port	17.5 - 21.5	Section 114-LOF
(Rossford, OH)	Flat glass	NR	Side-port	16.3 - 23.3	Section 114-LOF
Pressed/blown					
GTE Products (Versailles, KY)	Specialty glass	226		16.8 ^f	27
#1 furnace	Specialty glass	66		27.2 ^g	
#2 furnace					

See footnotes on following page.

TABLE 4-2. (continued)

NR = Not reported.

- a This furnace operation is not typical of container glass and uncontrolled NO_x emissions are at least twice those of other reported container glass furnaces. This may be due to the use of niter (sodium or potassium nitrate) in the glass batch formulation which contributes to NO_x emissions.
- b Calculated on the basis of a reported to total production rate of 655 ton/day for three furnaces after a postcombustion treatment system was installed²¹ and emissions of 875 ton NO_x/year before treatment and 505 ton NO_x/year afterwards²² and assuming 300 day/year operation.
- c This is the range of values reported for 8 different furnaces. Electric boost is used at all plants and ranges from 5 to 19.5 percent of the total energy requirement.
- d This is the range of values reported for 35 different furnaces. Electric boost is used at all plants and ranges from 4 to 16 percent of the total energy requirements.
- e This is the range of values reported for 54 different furnaces. Electric boost is used at all plants and ranges from 1.8 to 11.8 percent of the total energy requirements.
- f 3.99 lb NO_x/ton glass is from niter.
- g 12.77 lb NO_x/ton glass is from niter.
- h Data provided in Reference 26 is for the time period 1983-1993 and covers 28 separate measurements on flat glass furnaces with production rates from 380 to 677 ton/day. The average NO_x emission from this is 15.8 lb NO_x/ton glass. Because the specific sites are not identified in Reference 26, there may be some duplication of these data with the data provided by other flat glass manufacturers in their Section 14 responses.

directly proportional once the *assumption* of 6 MM Btu/ton glass is made. For oxy-firing, however, much less energy is needed because nitrogen is not present in the combustion air and energy is not used (and then lost up the stack) to heat it in the furnace. For oxy-firing, a value of 3.4 MM Btu/ton³² is reported, though this varies with different furnaces (which have different levels of air infiltration) and oxygen sources (which contain different amounts of nitrogen).

4.4 REFERENCES

1. Glassman, I. *Combustion*. 2nd ed. Academic Press. 1987. p. 328
2. Brunner, C.R. *Incineration Systems: Selection and Design*. Van Nostrand Reinhold. 1984. p. 112.
3. Joseph, G.T., and D.S. Beachler. APTI Course 415, Control of Gaseous Emissions. U.S. Environmental Protection Agency. Air Pollution Training Institute. EPA 450/2-81-006. December 1981. p. 7-4.
4. Zeldovich, J. The Oxidation of Nitrogen in Combustion and Explosions. *Acta. Physiochem.* 21(4). 1946.
5. U.S. Environmental Protection Agency. *Compilation of Air Pollutant Emission Factors, Vol. 1: Stationary Point and Area Sources*. Research Triangle Park, NC. Publication No. AP42 (GPA 055-000-00251-7). 4th ed. (including supplements A, B, C, and D). September 1991.
6. Fleming, D.K., and F.R. Kurzynske. NO_x Control for Glass-melting Tanks. In: 1985 Symposium on Stationary Combustion NO_x Control. Vol. 2: Industrial Processes, Fundamental Studies, and Slagging Combustors. EPRI. January 1986. p. 55-1.
7. MacKinnon, D.J. Nitric Oxide Formation at High Temperature. *J. Air Poll. Control Assoc.* 24(3). 1974.
8. Cooper, D.C. *Air Pollution Control: A Design Approach*. PWS Engineering. p. 458. 1986.
9. Edwards, J.B. *Combustion: The Formation and Emission of Trace Species*. Ann Arbor Science Publishers. 1974. p. 39.
10. American Society of Mechanical Engineers. *Combustion Fundamentals for Waste Incineration*. New York, NY. 1974.

11. Spinosa, E.D., D.T. Hooie, and R.B. Bennett. Summary Report on Emissions from the Glass Manufacturing Industry. U.S. Environmental Protection Agency. EPA-600/2-79-101. April 1979. p. 32.
12. Kirk-Othmer Encyclopedia of Chemical Technology. John Wiley. 3rd ed. 1981. v. 13. p. 850.
13. Charles River Associates. Glass Industry: Opportunities for Natural Gas Technologies. Gas Research Institute. Chicago, IL. Topical Report No. GRI-88/0266. September 1988. p. 3.
14. Ref. 1, p. 26.
15. Ryder, R.J. Use of Electric Boost to Reduce Glass Furnace Emissions. Ceram. Bull. 57(11):1025. November 1978.
16. Geiger, G. Environmental and Health Issues in the Glass Industry. Ceram. Bull. 71(2):194. 1992.
17. Tuson, G., R. Higdon, and D. Moore. 100% Oxygen Fired Regenerative Container Glass Melters. Presented at the 52nd Conference on Glass Problems. University of Illinois. Urbana-Champaign, IL. November 12-13, 1991.
18. Moore, R.D., and J.T. Brown. Conversion of a Large Container Furnace from Regenerative Firing to Direct Oxy Fuel Combustion. 1991 Glass Problems Conference. November 12-13, 1991. American Ceramic Society. Westerville, OH. 1992. p. 5.
19. Perrine, L.E. Glass Industry. p. 8. February 1992.
20. Ref. 16, pp. 194-195.
21. Teller, A.J., J.Y. Hsieh, and W. Van Saun. Control of Emissions from a Container Glass Furnace. Ceram Eng. Sci Proc. 10(3-4):312. 1989.
22. Ref. 21, p. 321.
23. Ref. 21, pp. 312-324.
24. Abbasi, H.A., and D.K. Fleming. Development of NO_x Control Methods for Glass Melting Furnaces. Gas Research Institute. Final Report No. GRI-87/0202. August 1987.
25. Neff, G.C. Reduction of NO_x Emissions by Burner Application and Operational Techniques. Glass Tech. 31(2):37. 1990.

26. Letter from Benney, J.C., Primary Glass Manufacturing Council, Topeka, KS, to W.J. Neuffer, EPA/OAQPS, August 3, 1993. Comments on uncontrolled NO_x emissions.
27. Fax message from Weikel, P., GTE Products, Versailles, KY, to Linzel, C., Columbia Dist. Company, Columbus, OH. August 31, 1992.
28. DeStefano, J.T. Postcombustion NO_x Control Technology for Glass Furnaces, Update. Presented at the 45th Glass Problem Conference. American Ceramic Society. Columbus, OH. p. 243. November 1984.
29. Abbasi, H.A., and D.K. Fleming. Combustion Modifications for Control of NO_x Emissions from Glass Melting Furnaces. *Ceram. Sci. Proc.* 9(3-4):168. 1988.
30. Shelley, S. *Chem. Eng.* pp. 67-69. December 1992.
31. Neff, G.C. Reduction of NO_x Emissions by Burner Application and Operational Techniques. *Glass Tech.* 31(2):39. April 1990.
32. Ref. 18, p. 4.

CHAPTER 5

CONTROL TECHNIQUES FOR NITROGEN OXIDES FROM GLASS MELTING

5.1 INTRODUCTION

Techniques for controlling NO_x emissions from glass melting furnaces can be divided into three basic types¹:

- combustion modifications
 - modified burners
 - oxy-firing

- process modifications
 - modified furnace
 - cullet/batch preheat
 - electric boost/all-electric melting

- postcombustion modifications
 - selective catalytic reduction (SCR)
 - selective noncatalytic reduction (SNCR).

Not all of these technologies have been demonstrated on the three types of glass furnaces considered here. In the following sections, the type of furnace in which these technologies have been demonstrated will be identified. In cases where the NO_x controls have not been demonstrated, technical judgments are made as to whether they could be applied.

5.2 COMBUSTION MODIFICATIONS

Combustion modifications refer to changes in the burner and flame to reduce NO_x emissions. A wide variety of such modifications have been introduced and studied, particularly on coal-fired industrial and utility boilers.² However, conditions in these boilers differ substantially from those found in modern regenerative glass melting furnaces.³ Specifically, these differences are as follows:

	<u>Boilers</u>	<u>Glass Furnaces</u>
Combustion air preheat	Moderate (~ 500-1000 °F)	High (2000-2500 °F)
Excess air levels	Low	High
Combustion chamber	"Cold walled" (low temperature)	Refractory-lined (high temperature)

All of these contribute to inherently higher NO_x levels in a glass furnace than in a boiler firing the same fuel at the same rate.

All combustion modifications are designed to minimize NO_x formation by reducing one or all of the following⁴:

- peak flame temperature,
- gas residence time in the flame zone, and
- oxygen concentration in the flame zone.

Reducing these three parameters is, of course, suggested by Equation 4-4, which expresses NO_x concentration as a function of these parameters. This equation also shows that reducing the peak flame temperature has the greatest effect on NO_x concentration, and many combustion modifications have focused on minimizing flame temperature.

In general, combustion modifications to minimize NO_x formation *in glass furnaces* can be grouped as follows^{1,5}:

- Modifications to existing burners and burner part hardware
 - low excess air operation
 - changing air/fuel contacting
- Modified burners.

Other general combustion modifications have been reported for NO_x control on other combustion processes, including fuel switching (usually from coal or oil to natural gas), water (steam) injection (used mainly in gas turbines)⁶ reduced air preheat, and derating.^{4,7,8} Flue gas recirculation can also be used independently of low NO_x burners (LNBs) on some combustion processes to reduce NO_x.^{9,10} However, the limitations of glass furnace operation (e.g., the need for high furnace temperatures requiring high combustion air preheat)¹¹ make such techniques infeasible. There are also tradeoffs, with such techniques as derating, between NO_x and overall energy efficiency and emissions of unburned hydrocarbons and CO.¹²

5.2.1 Modifications to Existing Burners

5.2.1.1 Low Excess Air (LEA) Operation. As recently as 30 years ago, many industrial furnaces routinely operated with 50 to 100 percent excess air.¹³ Increasing energy costs, requiring higher efficiency, gradually led to decreasing excess air. For utility boiler and other industrial combustion processes, LEA operation is now considered routine.¹⁴ Because air/fuel mixing is less than perfect in any combustion system, some excess air is a practical necessity. This ensures complete combustion of the fuel both for efficiency reasons and to minimize emissions of unburned fuel and hydrocarbons.

LEA is designed to reduce the oxygen concentration in the flame zone and therefore reduces NO_x formation, as shown in Equation 4-4. Figure 5-1 shows the qualitative effect of excess oxygen level on NO_x concentration ($\% \text{ excess oxygen} = \% \text{ excess air}$).¹¹ Data predicted by equilibrium as well as from tests on two glass furnaces are shown. The trend, showing increase in NO_x with increasing excess O_2 , is clear. Data is also available on the effect of excess air on NO_x .^{15,16} Tests on a commercial 140 to 165 ton/day Latchford Glass end-port furnace, a 250 ton/day side-port Diamond Bathurst furnace in Royersford, PA, and pilot scale tests are plotted in Figure 5-2. The data are presented in normalized terms, i.e., NO_x normalized to NO_x at 15 percent excess air. Absolute levels of NO_x produced at any given excess air level are not shown. However, the same trend is seen—increasing NO_x with increasing excess air.¹¹ Table 5-1 shows data taken on the two commercial furnaces on NO_x reductions as a function of excess air.^{15,17} As expected, lower excess air leads to lower NO_x emissions in both furnaces. Reductions of 28 percent were achieved in both cases, though the excess air was much greater in the side-port furnace. There are, of course, practical limits to the amount of excess oxygen required to achieve efficient combustion and energy use and to minimize other emissions.

5.2.1.2 Changing Air/Fuel Contacting. As shown in Figure 5-3, regenerative glass furnaces are generally fired by mixing a horizontal stream of preheated combustion air with a stream of natural gas fuel injected in a much smaller separate port at an angle. The natural gas fuel can be injected below (underport firing), beside (sideport firing), or above (overport firing) the combustion air, though below is apparently the most common. Typical fuel injection velocities are of the order of 500 to 800 ft/sec. The mixing of the fuel and air is accomplished by the difference in this high velocity and the much lower

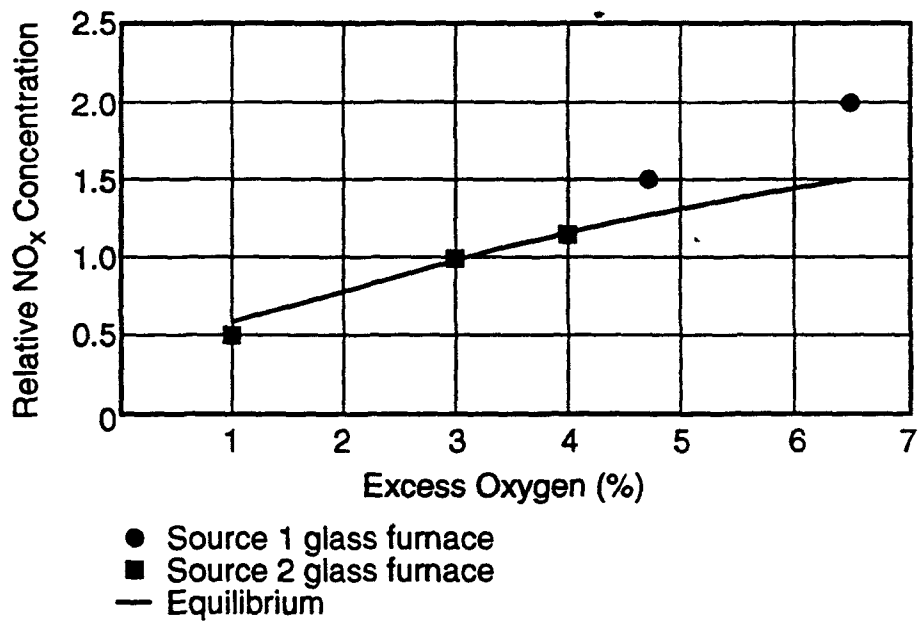

Figure 5-1. Effect of excess oxygen on concentration of NO_x.¹¹

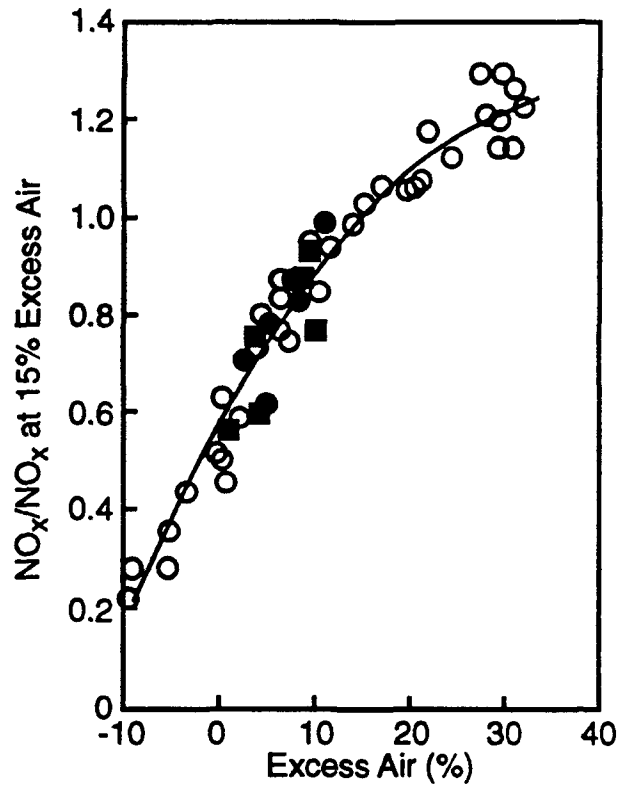

Figure 5-2. Effect of excess air level on NO_x (O pilot-scale; ● commercial end-port; ■ commercial sideport).¹⁵

TABLE 5-1. EFFECT OF EXCESS AIR ON NO_x IN COMMERCIAL FURNACES

	Excess air level (%) ^a	Furnace pull (ton glass/day)	NO _x (lb/ton glass)	NO _x reduction ^b (%)	NO _x conc. (ppm, 0% O ₂)
Commercial side-port furnace (Diamond Bathurst)	12.5 ^c	255	9.3	28	2430
	18.2		13.0	-0-	3240
	18.4		12.9	- ^c	3100
Commercial end-port furnace (Latchford Glass)	4.5 ^d	164	5.2	28	924
	7.4		6.3	13	1140
	9.1		7.2	- ^c	1320

^a Calculated from data provided by Abbasi and Fleming.¹⁷ In this work, Tables 3 (p. 41) and 9 (p. 90) present data for the end-port and side-port two furnaces, respectively, in terms of percent O₂. Table 3 adds the qualifying term "in port." It is assumed here that the oxygen levels reported are directly comparable and provide a measure of the excess combustion air. There is some difference in the sample locations used to check the exhaust gas oxygen concentration. Abbasi and Fleming describe this on p. 33 and p. A-3 for the end-port furnace and on p. 82 for the side-port furnace.¹⁵ Assuming the fuel is pure methane, the percent *excess air* (or excess oxygen) can be calculated from the oxygen concentration *in the flue gas*, which is reported in some cases by Abbasi and Fleming,¹⁷ assuming *no* infiltration of outside air, as follows ($x = \% O_2$ in flue gas, expressed as a decimal, i.e., 2% oxygen in flue gas would be expressed as 0.02):

$$\% \text{ Excess air} = \frac{4.54x}{(1-x)} (100\%) .$$

^b Percent reduction for each furnace is calculated relative to the highest value of NO_x (lb NO_x/ton glass) reported for each furnace. For example, for the side-port furnace, the percent NO_x reduction for 12.5 percent excess air is (12.9-9.3) lb NO_x/ton glass ÷ 12.9 = 28%.

^c All excess air values for this furnace are averages of data taken individually on each of the four firing ports.

^d All excess air values for this furnace are averages of two data points, one for right-side firing and one for left-side firing.

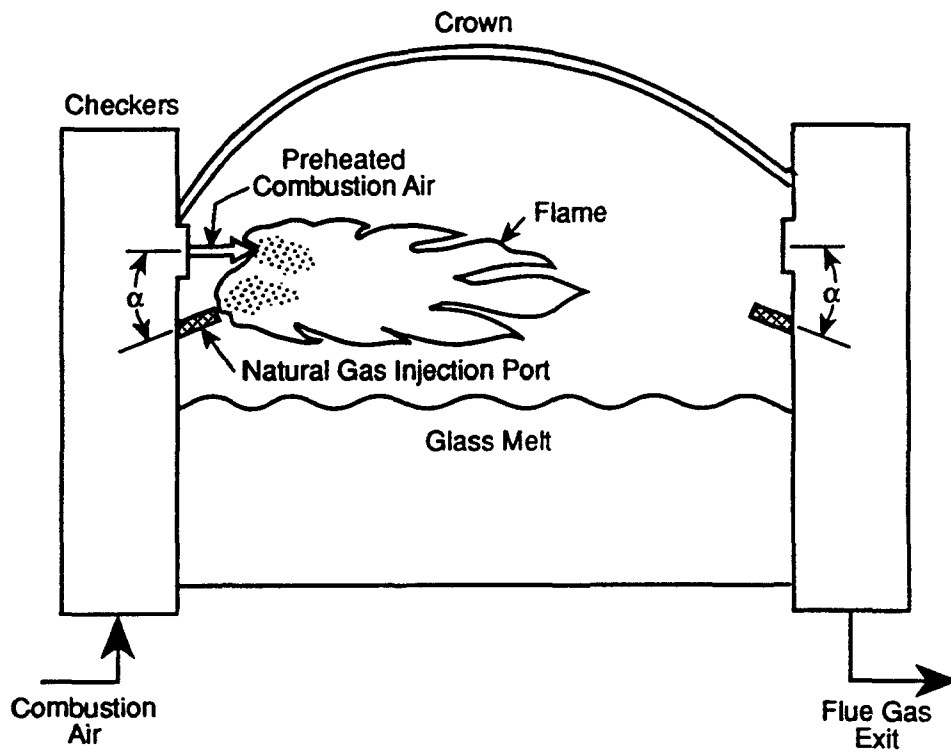

Figure 5-3. Glass furnace burner configuration.

velocity of the preheated combustion air, typically around 20 to 30 ft/sec.^{18,19}

There are several independent variables that can be changed to reduce NO_x formation in such burners. These include the contact angle between the gas and combustion air, air and gas velocities, and location of the natural gas injection (e.g., underport or overport). However, the ability to change these variables in an operating furnace can be quite limited due to furnace and firing port geometry and the way the combustion air is introduced into the furnace. As expected, each of these affects the three primary variables that influence NO_x formation—flame temperature, oxygen concentration, and gas residence time at peak temperatures. A series of studies investigated the effects of these variables on NO_x formation in regenerative glass furnaces.^{15,17} Using data and correlations obtained from a one-quarter scale pilot scale furnace, tests on two commercial furnaces were carried out (see Section 5.2.1.1 and Table 5-1).

The tests also examined the effect of underport firing (fuel injected beneath the combustion air) versus side-port firing (fuel injected beside the combustion air) on the end-port furnace. Representative test conditions and results are summarized in Table 5-2.^{15,17} This table summarizes the range of operating conditions used to determine the effect of excess air and air/fuel contacting on NO_x emissions.

The results generally showed that NO_x is minimized by "long, lazy" luminous flames. This is consistent with reduction of peak flame temperature and gas residence time at peak temperatures. The effect of excess air from this study is discussed in Section 5.2.1.1. Specifically, NO_x was reduced by:

- reduced air velocity,
- reduced fuel velocity,
- reduced contact angle between fuel and air, and
- underport firing (compared to sideport firing; overport firing was not

investigated).

The effect of the first three parameters (air and fuel velocities and contact angle) is accounted for in a "mixing" factor defined as follows:

$$M_f = V_a \sin \alpha + 4.7 F_a V_f^{1/2} \quad (5-1)$$

where M_f = mixing factor
 V_a = "effective" air velocity, ft/sec

TABLE 5-2. REPRESENTATIVE TEST CONDITIONS

	End-port furnace	Side-port furnace
Company	Latchford Glass	Diamond-Bathurst
Location	Huntington Park, CA	Royersford, PA
Furnace size, ton/day	140-165	250
Excess air, %	7-10	10 ^a
Air preheat, °F	2200	2200-2500
Fuel velocity, ft/sec ^b	550-1200	390-610
Air velocity, ft/sec	18	30
Firing rate, 1 MM Btu/ton	5.2	4

a

Reference 20.

b

Pont reports that end port furnaces typically use lower fuel injection velocities than side-port furnaces, contrary to the conditions reported here.²¹ This may be due to the higher than normal air velocity of the Diamond-Bathurst side-port furnace.

α = air/fuel contact angle

F_a = fraction of air that mixes directly with the fuel, $0 < F_a < 1$

V_f = "effective" fuel velocity, ft/sec.

As noted in Section 5.1, there is a limited range over which these variables can be changed in a working furnace.²² Figure 5-4 shows the effect of a modified mixing factor (accounting for scaleup) on NO_x concentration, based on data from one-quarter pilot scale tests (closed points) and commercial side-port and end-port furnaces (open data). The general trend is as expected, i.e., NO_x is reduced by decreasing air and fuel velocities and reduced contact angle. Significant differences were observed in NO_x formation in the two commercial furnaces, even at nominally identical conditions. This was attributed to conditions otherwise not accounted for in the correlation given above, e.g., high combustion air velocity in relatively short ports in the sideport furnace which caused more gas mixing, and therefore higher peak flame temperatures and NO_x , than in the end-port furnace. Such site-specific factors are not included in the correlation but may have a significant effect on NO_x . Nevertheless, in any given furnace, the qualitative *effect* of air/fuel velocity and contact angle of Equation (5-1) should be expected. For example, Figure 5-5 shows that decreasing the fuel injection velocity lowers NO_x concentration for a wide range of contact angles, port configurations, and burner types.²⁴

Another type of burner uses methane dissociation and slight oxygen enrichment (20.9 percent to 21.7 percent) increases flame luminosity in glass furnaces.^{16,25} This increased luminosity increases heat transfer from the flame to the melt, lowering energy requirements, and decreasing NO_x emissions (lb NO_x /ton glass or lb/ NO_x /MM Btu). Though tests are planned, no test results are available. A claim of 35 percent NO_x reduction or a fuel savings of 6 percent is made. However, no absolute values of NO_x emissions are provided.

5.2.2 Modified Burners

Low NO_x burners (LNBs) have been developed for a wide range of utility and industrial boiler applications, primarily for coal- or oil-fired applications. A great deal of literature is available describing LNB performance in these applications (e.g., References 2 and 5). The distinguishing feature of LNBs is the staging of the combustion process in several distinct zones. A general description of such burners is provided in references 6, and 26 - 28. This staging, by definition, is accomplished in the burner itself rather than in the furnace. In a two-stage LNB, combustion is fuel rich in the first stage and air rich in

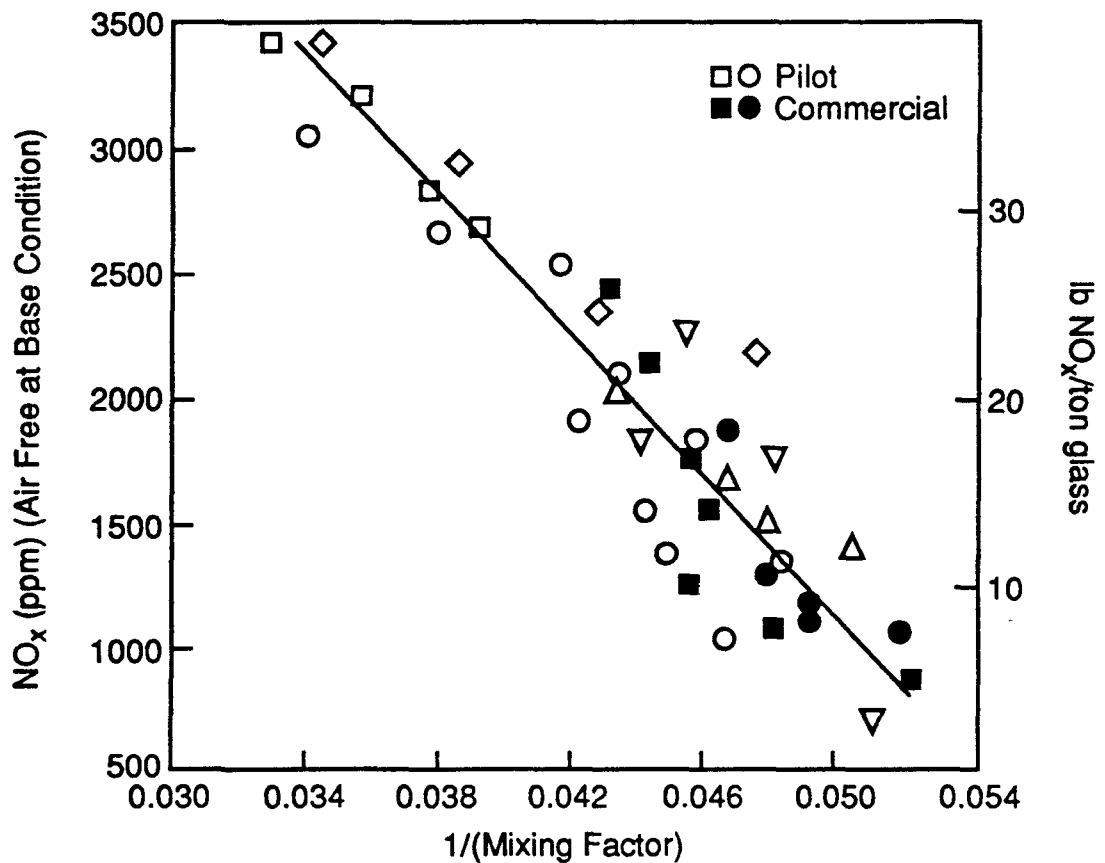

Figure 5-4. Agreement of normalized commercial data with modified mixing factor correlation.²³ Right hand scale calculated assuming 68 scfm per ton/day of glass (see footnote b of Table 5-9) and NO_x as NO.

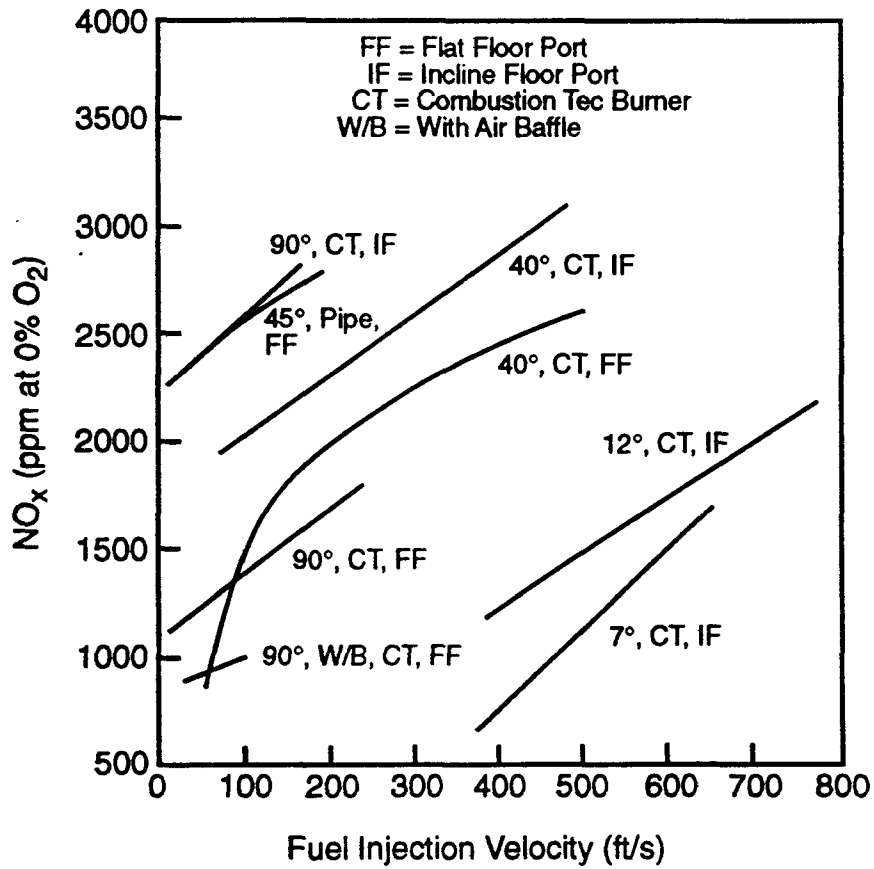

Figure 5-5. Effect of fuel injection velocity on emission of NO_x.²³

the second. This minimizes the peak flame temperature and corresponding oxygen concentration and thus minimizes NO_x formation. Burners have been designed with a variety of contacting schemes to improve both NO_x reduction and fuel efficiency. A diagram showing the essential features of a three-stage coal-fired LNB is shown in Figure 5-6.⁷ NO_x reductions of around 30 to 50 percent or higher over older design burners are possible.^{6,10,29} Many currently available burners for glass furnaces include features to allow adjustment of air/fuel velocities, contact angle, flame shape, and injection orifice. Each of these can result in NO_x reduction (see Section 5.2.1), but do not include all of the features that characterize what are commonly known as LNBs.

5.2.2.1 Sorg Burner. A 1991 report states that ". . . no LNBs are yet available "off the shelf" for glass furnaces."^{30,31} However, a staged burner developed by Sorg GmbH (Cascade™ burner) has been tested recently on two container glass furnaces.³² This staging is the defining feature of what is generically called a low NO_x burner. This, then, apparently represents the recent development of an LNB for glass furnaces. Figure 5-7 shows the staging of the natural gas fuel in a primary and secondary flame in a regenerative glass furnace. As in other LNBs, this staging reduces the peak flame temperature, and thus NO_x formation.

This burner has been tested on two container glass furnaces, as shown in Table 5-3. In the test on the end-fired regenerative furnace, NO_x emissions were reduced from 6.04 to 2.43 lb/ton (60 percent) from uncontrolled levels by a combination of furnace and burner block sealing to limit air infiltration (accounting for a reduction from 6.04 to 4.13 lb/ton) and use of the Cascade™ burner (accounting for a further reduction from 4.13 to 2.43 lb/ton). A second test in which one of five ports in a cross-fired regenerative furnace was fitted with a Cascade™ burner resulted in *overall* furnace NO_x emissions reduction from an uncontrolled level of 9.21 lb/ton to 5.86 lb/ton.

Both of these tests were on container glass furnaces with "under-port" firing, in which the fuel is injected below the port from which the preheated air enters the furnace as shown in Figure 5-7. Although apparently common in container glass furnaces, under-port firing is not typically used in flat glass furnaces in the United States, though it is used in flat glass furnaces elsewhere in the world.³¹ Thus, the use of this burner in flat glass furnaces, has not been demonstrated and may present some difficulties.³³ No information is available on the applicability of this burner to pressed/blown glass furnaces.

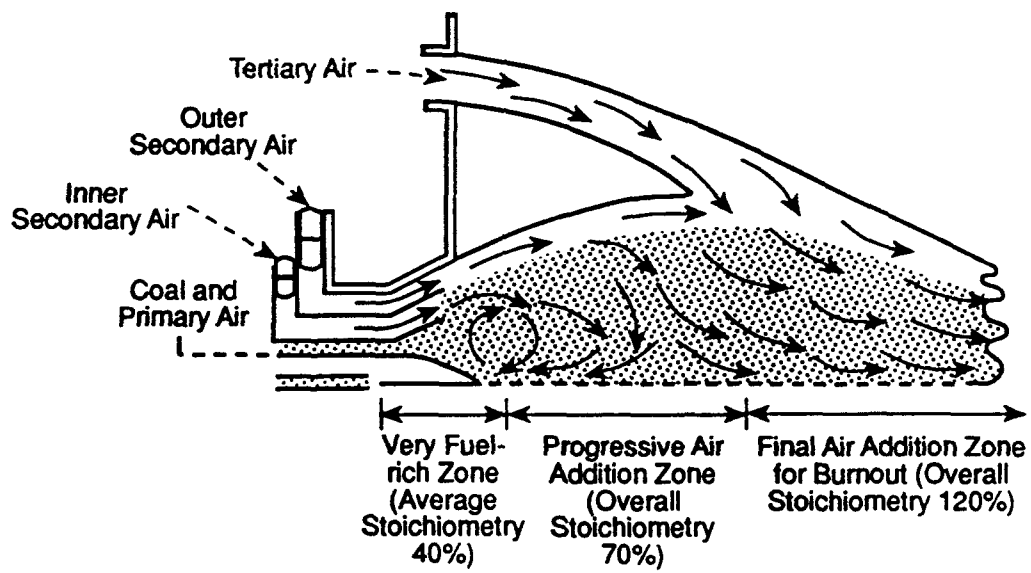

Figure 5-6. Low-nitrogen oxides burner with multistage combustion.⁷

TABLE 5-3. RESULTS OF NO_x TESTS USING CASCADE™ BURNER

Furnace	NO _x emissions					
	Uncontrolled		With basic measures ^a		With basic measures and Cascade™ Burner	
	lb/hr	lb/ton	lb/hr	lb/ton	lb/hr	lb/ton
End-fired, regenerative container glass 70 m ² 220 ton/day oil-fired 6% electric boost	60.9	6.04	41.6	4.13	23.1	2.43 ^b
Cross-fired, regenerative ^c container glass 94 m ² 255 ton/day oil fired w/natural gas atomization	107.7	9.21	basic measures (not applied)		68.5 ^c	5.86 ^c

^a "Basic measures" include the following: furnace and burner block sealing to prevent cold air infiltration; optimization of furnace pressure; reduction of furnace temperature; optimization of fuel exit velocity, burner angle, primary air, burner nozzle cooling.

^b Allowance has been made for electric boost, i.e., actual emissions measured with 6 percent electric boost have been increased by a factor of 1/0.94 or 1.06 to show what NO_x emissions would be without electric boost.

^c Only one of five ports was equipped with a Cascade burner™; apparently this furnace was not electrically boosted

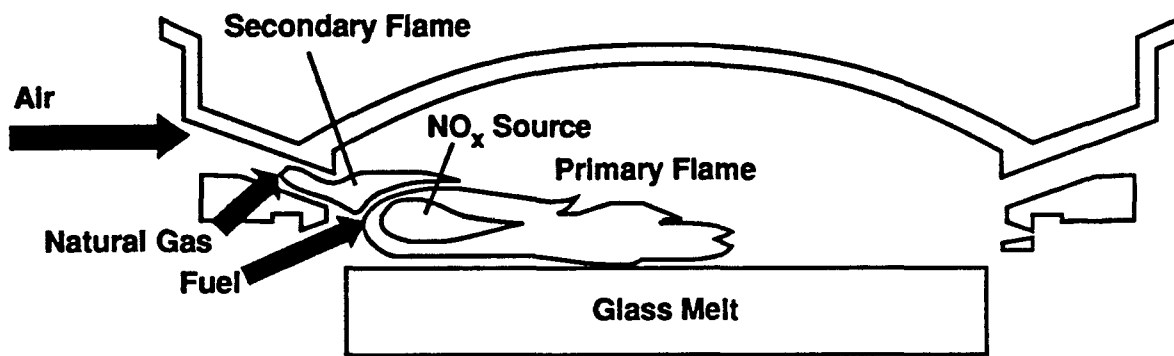

Figure 5-7. Sorg Cascade™ burner.³²

5.2.2.2 Körting Burner. Körting (Hannover, Germany) has reported the development of a "reduced NO_x burner" that incorporates orifice sealing (to prevent in-leakage of air), flue gas recirculation, and a "staged air" system to minimize NO_x.³⁴⁻³⁷ This "staged air" process injects additional air *into* the end of the furnace *outside* of the burners, and is therefore not the same as the staged air referred to above for LNBs (see Figure 5-8). Figure 5-9 shows the burner itself. Natural gas enters through a jet nozzle, creating a vacuum to draw in atmospheric air. Control of this "primary air" can be used to vary the velocity of the gas/air mixture from the burner tip and provide enough air so that partial combustion of the gas, at 800 to 1000 °C (1470 to 1830 °F), takes place. This burner was tested on a 179 tons/day regenerative end-port gas-fired container glass furnace.³⁴ No reports of its use on flat or pressed/blown glass furnaces are available. The uncontrolled NO_x concentration was approximately 2,240 ppm. For this test, the "atmospheric air" of Figure 5-9 was replaced by 280 °C (535 °F) flue gas drawn from the regenerator and is shown in Figure 5-10. This reduces NO_x by minimizing the oxygen content of the combustion air. The net effect of the orifice sealing, flue gas recirculation, and staged air was to reduce NO_x concentration to 600 to 750 ppm, i.e., by around 65 to 70 percent. Staging of the air had the greatest single effect on NO_x reduction, about 50 percent by itself. Table 5-4 summarizes more detailed data on this same furnace.³⁶ From baseline emissions of 2,284 ppm from one group of burners, flue gas recirculation and staged air reduced NO_x emissions by 16 to 44 and 66 percent, respectively. Combining the two techniques gave no improvement over staged air alone, at least for the 14 percent staged air tests for which direct comparisons can be made. Also note that decreasing the oxygen concentration from 4 to 3.7 and 2.7 percent using flue gas recirculation lowered NO_x emissions by 24 and 44 percent of the baseline value but increased CO emissions, as expected (see Figure 5-17 and Section 5.3.1).

5.2.3 Oxygen Enrichment/Oxy-Firing

Oxygen enrichment refers to the substitution of oxygen for nitrogen in the combustion air used to burn the fuel in a glass furnace. This enrichment can be anywhere from its level in ambient air (21%) up to nearly 99 percent. Oxygen enrichment above 90 percent is sometimes called "oxy-firing." Oxy-firing has been demonstrated only in container³⁸ and pressed/blown^{39,40} glass furnaces to date, not in flat glass furnaces. The conversion of a small (85 ton/day) "flat glass" furnace to oxy-firing is discussed.⁴⁰ However, this furnace does not produce the high quality glass made by the float process in

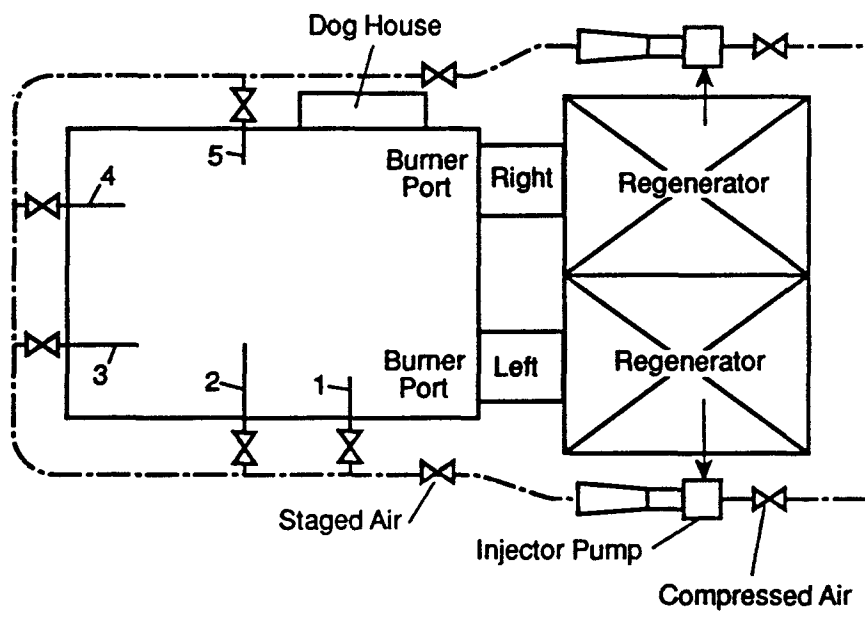

Figure 5-8. Air staging on a regenerative horseshoe-fired furnace. 1 to 5: sight hole numbers of the furnace.³⁶

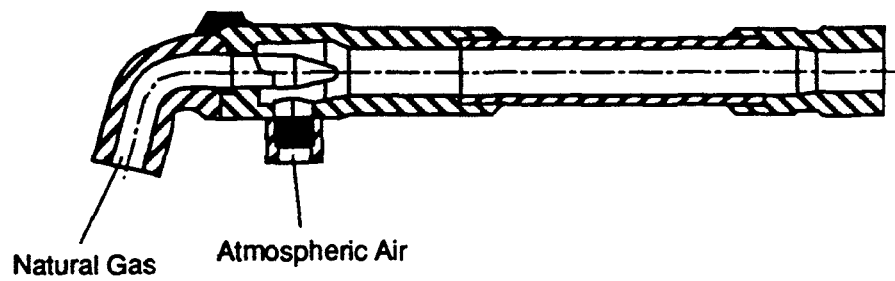

Figure 5-9. Körting gas jet.³⁴

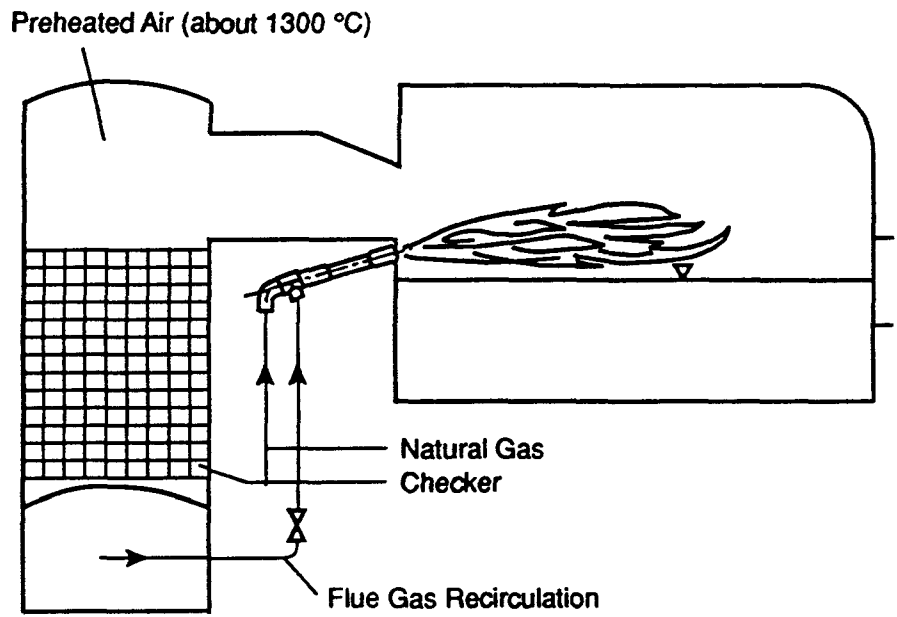

Figure 5-10. Flue gas recirculation on regenerative glass melting furnaces.³⁶

TABLE 5-4. EFFECT OF BURNER MODIFICATION ON NO_x EMISSIONS³⁶

Burner modification	NO _x ^a			CO		NO _x reduction from baseline (%)
	O ₂ (vol%)	mg/m ³	ppm ^b	mg/m ³	ppm ^b	
Baseline	4.0	3045 ^c	2284	0	—	—
Flue gas recirculation	4.0	2563 ^d	1922	30	24	16
	3.7	2300	1725	96	77	24
	2.7	1701	1276	501	401	44
Staged air (14%) ^e	1.8	1034	776	374	299	66
Staged air (14%) ^e with flue gas recirculation	1.8	1046	785	486	389	66

^a Flue gas flow rates, which are needed to calculate NO_x emissions in units of lb NO_x/ton glass produced, are not provided by the authors.

^b 1 mg NO/m³ = 0.75 ppm NO at STP; 1 mg CO/m³ = 0.80 ppm CO at STP.

^c Average of values for right and left side of furnace, 2993 and 3097 mg NO_x/m³, respectively.

^d Average of two data points at slightly different flue gas recirculation flow rates: 2458 mg/m³ @ 262 m³/hr and 2668 mg/m³ @ 279 m³/hr.

^e These data for staged air are taken at around 14 percent staged air, i.e., 14 percent of the total combustion air injected downstream of the burners (see Figure 5-8).

much larger furnaces, but rather lower quality, rolled "flat glass." Thus, oxy-firing has not yet been demonstrated in what is called "float" (or "flat") glass furnaces herein.] Little has been reported on oxygen enrichment in glass furnaces at total O₂ concentration levels of less than 30 percent. Enrichment to these low levels can be done in two ways⁴¹:

- Oxygen enrichment.

This technique is sometimes called "premix." Oxygen is added directly to the combustion air to prolong furnace life and increase productivity. It is usually used to enrich the combustion air up to about 35 percent O₂ and is the most practical for retrofit situations since most air-fuel burners can be used without major modification.⁴² This usually increases NO_x, consistent with Figure 5-11.⁴³ Enriching the combustion air oxygen content from 20.9 percent to 21.7 percent would be expected to increase the flame temperature by 11 °C (20 °F) and to increase NO_x emissions by 10 percent.⁴⁴

- Oxygen lancing.

This technique is sometimes called "undershot." Pure oxygen is injected below an air-fuel burner to increase productivity. NO_x is usually not greatly affected, though at least one report describing a modified oxygen lancing technique used to combust around 4 percent of the total fuel at four container glass plants in the UK, showed NO_x increased from 968 ppm to 1073 ppm, about 11 percent.³⁵ Field data show that "improper" lancing of corresponding to 3 percent oxygen enrichment (i.e. from 21 to 24 percent O₂ in the combustion air) actually doubled NO_x emissions.⁴¹

Because only oxy-firing generally results in lower NO_x emissions, it is the primary focus here, though lower levels of oxygen enrichment have been reported on glass furnaces.⁴⁵

The basic rationale for oxy-firing is improved efficiency, i.e., more of the theoretical heat of combustion is transferred to the glass melt and is not lost in the flue gas. Many of the combustion modification techniques discussed (e.g., flue gas recirculation, staged combustion, and low excess air combustion) reduce NO_x formation but also reduce the combustion efficiency.⁴⁶ Oxy-firing was originally developed to improve the combustion efficiency primarily by eliminating the sensible heat lost in heating the nitrogen present in air, which is then lost in the flue gas.⁴⁷⁻⁴⁹ The equations below compare oxy-firing combustion of methane with conventional combustion using air:

In air

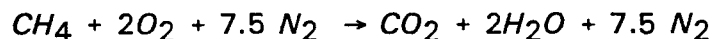

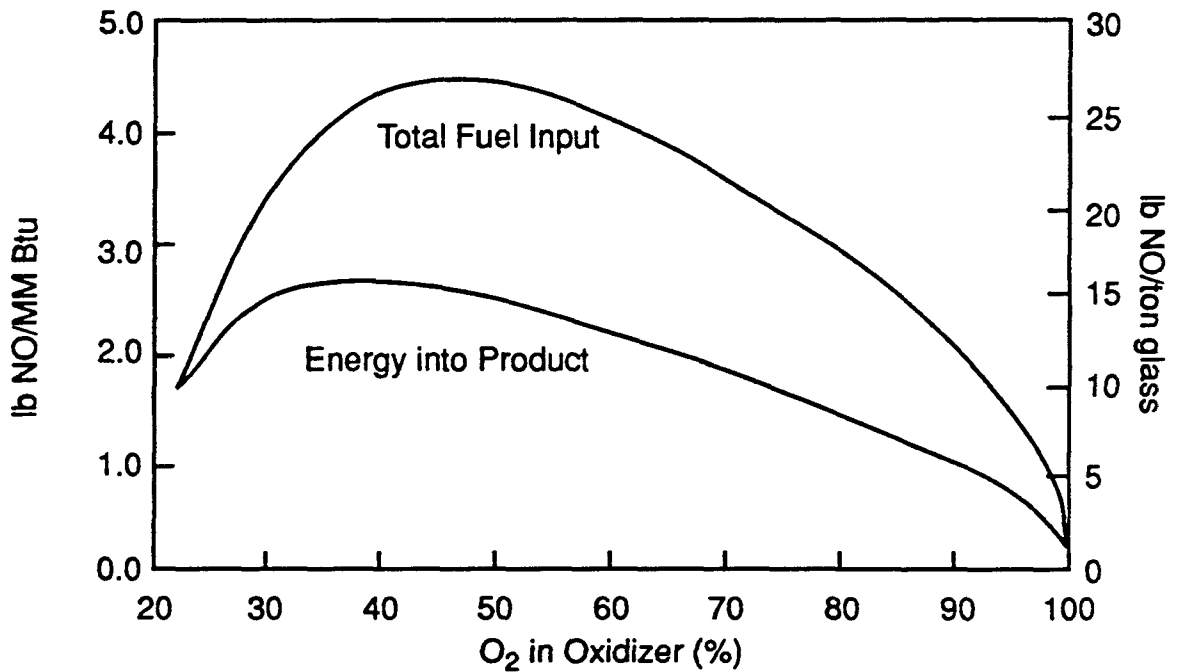
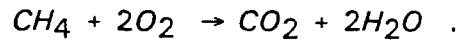

Figure 5-11. Adiabatic equilibrium NO (given in lb/MM Btu) versus percent oxygen in the oxidizer for a methane flame based on gross energy input (overall firing rate) and net energy into the product.⁴³ Right-hand scale is calculated assuming 6 MM Btu/ton glass (see Chapter 4).

Oxy-firing



The difference is that heat is lost as the nitrogen in the combustion air is heated and then sent up the stack. Also, the volumetric flow rate of the flue gas is 3.5 times larger when air is used than when oxygen is used. This increases fan, duct, and any gas treatment (e.g., SNCR) costs.

Nitrogen, which must be present for NO_x to form, is introduced in the furnace from several sources besides the combustion air. Thus, some NO_x formation is inevitable even when using oxy-firing. Nitrogen is invariably present in the natural gas fuel used at glass plants, usually in concentrations from 0.5 to 3 percent. Nitrogen is also an inevitable contaminant in the oxygen, even when cryogenically distilled oxygen is used, though the concentration is very low in this case. Nitrogen concentrations of about 100 ppm are typical.⁵⁰ If pressure swing adsorption is used to produce oxygen, the nitrogen content is around 2 to 5 percent.⁵¹ The largest source of nitrogen is usually air infiltration into the furnace. This is, of course, highly site specific but experience has shown that even the best pressure controls on the furnace, usually designed to keep the furnace at slightly positive pressure, allow at least some air leakage into the furnace. In many cases, air infiltration is the single largest source of nitrogen in the furnace.⁵² Practical operating constraints and furnace degradation with time generally mean that the nitrogen concentration in a working furnace cannot be reduced below 5 to 10 percent, including nitrogen from all sources.⁵³ The source of the nitrogen (from the fuel, oxygen, or air infiltration) can greatly affect the amount of NO_x formed.⁵⁴ This is to be expected since, for different burner types, mixing of the N_2 in that part of the flame where NO_x is formed is different depending on how it is introduced into the flame.

Increasing oxygen concentration also causes the temperature of the flame to increase. Any increase in flame temperature will increase the formation of NO_x . Figure 5-12 shows the adiabatic flame temperature for methane as a function of the oxygen content in the combustion gas.⁵⁵ In glass melters, the actual flame temperature will be somewhat less because heat is transferred from the flame to the glass melt. Nevertheless, a substantial increase in flame temperature, and therefore NO_x formation, with oxygen content would be expected. The increase in flame temperature with oxygen content

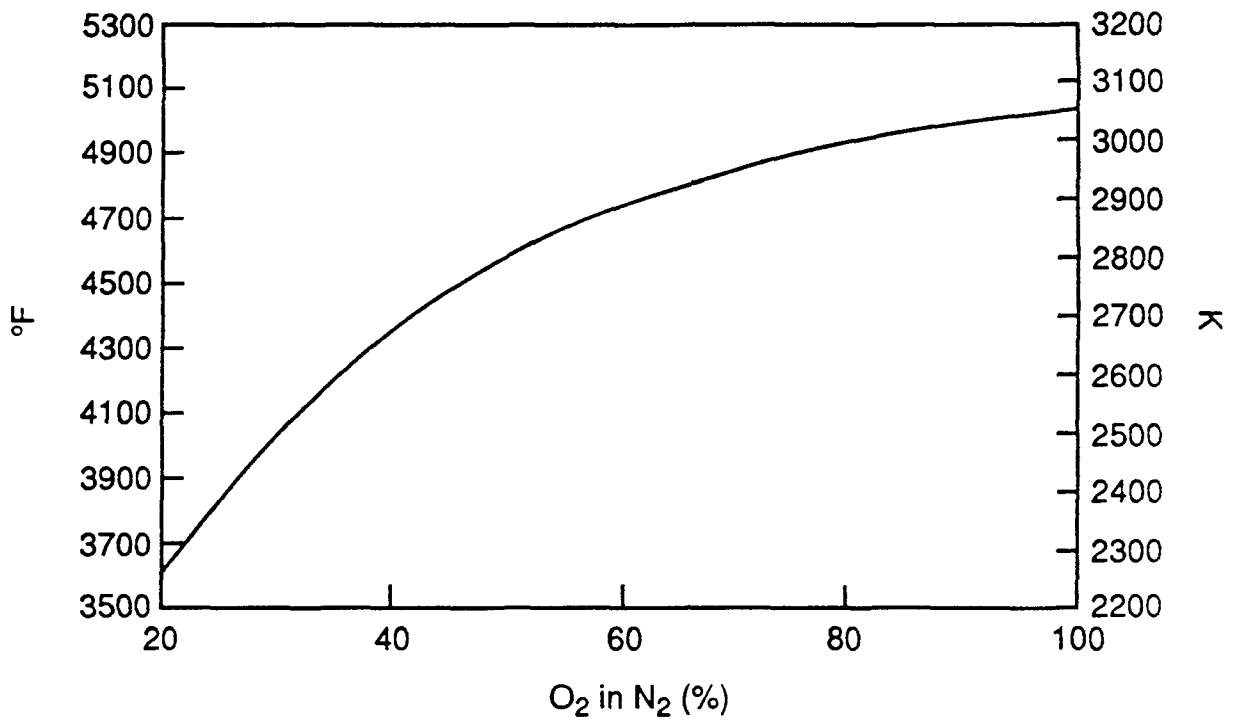

Figure 5-12. Adiabatic flame temperature versus percent oxygen in the oxidizing stream consisting of oxygen and nitrogen.⁵⁵

results in a higher rate of heat transfer to the glass for a given rate of fuel being burned.

As shown in Figure 5-13, the effect of oxygen concentration on NO_x formation is not straightforward. Increasing oxygen concentration from the 21 percent in ambient air to around 60 percent actually increases the *equilibrium* NO concentration.⁵⁵ This is a result of the higher flame temperature and higher O_2 concentrations. As shown in Figure 5-12, above 60 percent O_2 , the equilibrium NO concentration decreases, due to the lower N_2 concentration, even though the adiabatic flame temperature continues to increase. Another way to look at NO formation for glass melting is to plot the weight of NO formed per unit weight of glass produced, e.g., lb NO/ton glass produced. Glass production is directly proportional to net energy transferred to the glass product, which is in turn directly proportional to the fuel firing rate. Figure 5-11 shows the *equilibrium* NO per unit fuel fired (lb NO/MM Btu) versus oxygen content. The important difference between Figures 5-11 and 5-13 is that the NO produced, at equilibrium, *per unit of glass produced*, actually *decreases* monotonically above about 30 percent O_2 , rather than above 60 percent O_2 that might be expected from Figure 5-13.

This trend in equilibrium NO concentration, shown in Figure 5-11, was confirmed in practice, at least qualitatively, in a series of tests funded by the Department of Energy⁵⁶ and Gas Research Institute.^{46,57} Figure 5-14 shows the *actual* NO produced per unit fuel input as a function of oxygen content, for oxygen concentrations above 90 percent. This corresponds to the upper end of the theoretical plot given in Figure 5-11. The trend in NO production at this level of O_2 is important since the nitrogen concentration in a working glass furnace is 5 to 10 percent,⁵³ corresponding to oxygen concentrations of 90 to 95 percent, as shown in Figure 5-13. The NO produced in these tests is actually somewhat less than predicted by the equilibrium values given in Figure 5-11, suggesting that the formation of NO in a working furnace is a rate-controlled process rather than a thermodynamically controlled one. This is why Equation (4-4), Section 4.1.1, shows NO_x concentrations to be linear with nitrogen concentrations rather than proportional to the square root of nitrogen concentration, as would be expected at equilibrium. Assuming a value of 6 MM Btu/ton of glass⁵⁸ (also see Chapter 3), the right-hand scale of Figure 5-14 shows the lb NO/ton glass produced in these tests. The important result for these series of tests is that the NO_x emissions for high levels of enrichment (>90% O_2) were at least an order of magnitude *lower* than for low levels of enrichment (<28% O_2). This is

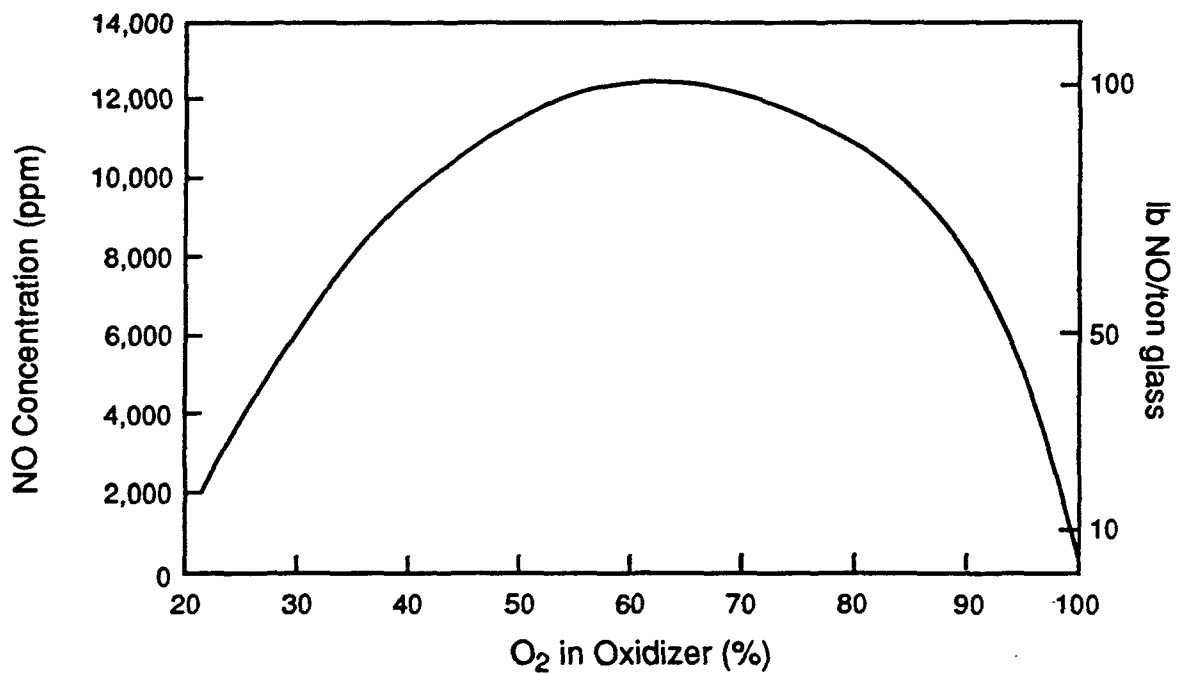
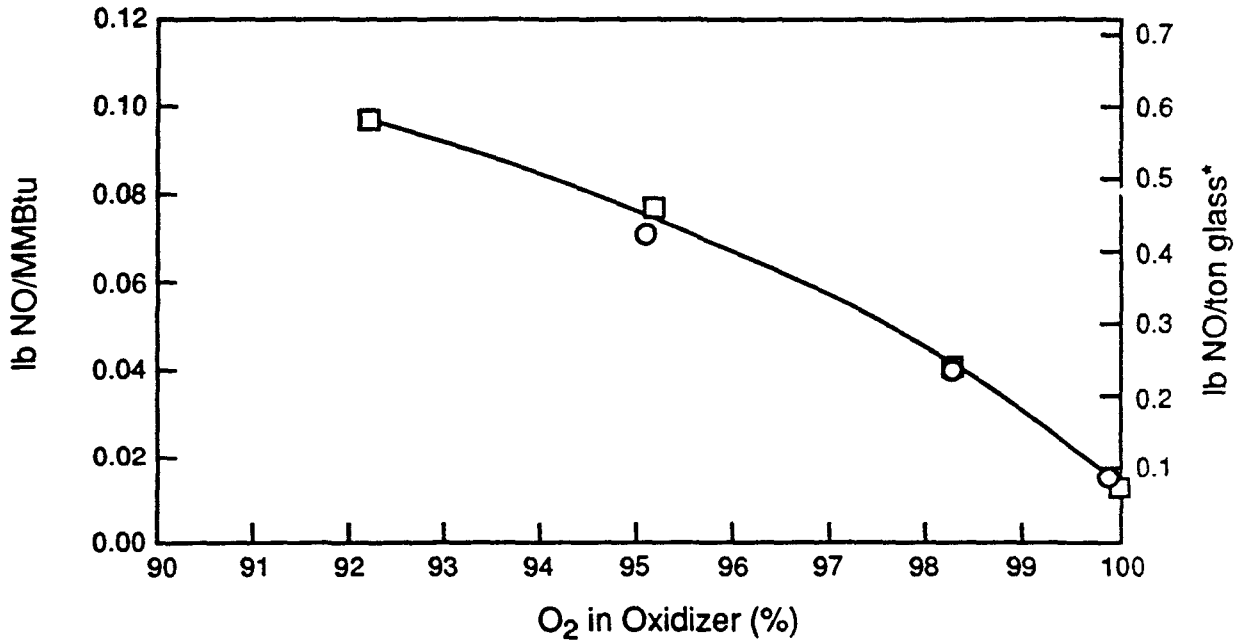

Figure 5-13. Adiabatic equilibrium NO given in ppm and lb/MMBtu (gross firing rate) versus percent oxygen in the oxidizer for a methane flame.⁵⁵ Right hand scale is calculated assuming 68 std. cu. ft. per ton/day of glass produced (see footnote b of Table 5-9).



*assuming 6 MM Btu/ton of glass

Figure 5-14. Flue nitric oxide versus percent oxygen in the oxidizer for an Air Products' K-Tech burner firing on natural gas.⁴⁶

contrary to a widely held perception that the use of oxygen inevitably leads to higher NO_x emissions, regardless of the O_2 concentration.⁵⁷ Also, unlike air-fuel combustion, typical oxy-firing produces NO at concentrations that *decrease with increasing* furnace temperature. This is because NO concentrations that are above the equilibrium value calculated at the *furnace* temperature (due to the very high adiabatic *flame* temperature) are produced.⁵⁹ As the oxy-fired flame cools rapidly to a low furnace temperature, a high NO concentration, corresponding to that produced at the high oxy-fired flame temperature, is "frozen." If, however, a less rapid cooling takes place, which happens if the furnace temperature is higher, the NO formed at the high flame temperature decomposes and approaches the lower value corresponding to the furnace temperature.

Oxy-firing is especially valuable as a retrofit technology. However, conventional burners must be replaced. Air Products (Allentown, PA) and Combustion Tec (Orlando, FL) have developed burners that are designed to minimize furnace temperature variations in retrofit situations, the benefit being about half the fuel usage for the same temperature profile,^{60,61} or higher productivity (ton glass produced per unit of fuel fired) from the same furnace.

Tests by Union Carbide on oxy-firing of glass melters on a pilot scale furnace showed large differences in NO_x produced by different burner "types," which are not further described.⁵⁴ However, the qualitative trend shown in Figure 5-11 was confirmed, i.e., NO_x (lb NO_x /MM Btu) decreased with increasing oxygen concentration over the range of 35 to 100 percent O_2 . Larger scale tests were conducted on a 75 tons/day, 300 ft² end-fired regenerative container glass melter fired with pure oxygen. Table 5-5 shows the results, comparing air-fired with "100 percent oxy-firing." [It was not possible during these tests to get NO_x emission data at identical production rates (ton of glass/day). Therefore, the data in Table 5-5 provide only qualitative comparison of air versus oxy-firing.] The higher than expected nitrogen content of the furnace atmosphere in Table 5-5 during the two periods of "100 percent oxy-firing" (38 percent and 30 percent) are due to large infiltration of air into the furnace. This, of course, contributes to higher levels of NO_x formation than would otherwise be the case. Also, the batch ingredients for this container glass contain 7.5 lb niter (as NaNO_3) per ton of glass produced. If this were all converted to NO_2 , it would yield 2.7 lb NO_2 per ton of glass. Though the actual conversion to NO_2 is probably less than complete, this accounts for most of the higher than expected NO_x values (2.9 and 2.1 lb/ton glass) for the two oxy-firing cases in Table 5-5. The high

TABLE 5-5. NO_x EMISSIONS—75 TPD GLASS FURNACE⁵⁴

	Air	Oxygen	Oxygen
Pull (ton/day)	62.7	46.8	75.8
Bridgewall temperature (°F)	2676	2672	2766
Fuel (MM Btu/hr)	13.6	8.9	13.7
Flue gas (scfm)	200,000	53,000	66,000
Furnace atmosphere			
N ₂ (% wet)	72	38 ^b	30 ^b
H ₂ O (% wet)	14	36	43
CO ₂ (% wet)	9	22	26
O ₂ (% wet)	5	4	1
NO _x (lb/hr)	56.4	5.75	6.5
(lb/MM Btu)	4.28	0.68	0.5
(lb/ton)	21.6	2.9 ^a	2.1 ^a
NO _x from niter (@ 100% conversion)			
(lb/hr)	7.0	5.2	8.5
(lb/ton)	2.7	2.7	2.7

^a Most NO_x from niter.

^b This high nitrogen concentration was due to considerable infiltration of air into the furnace.

nitrogen contents of the furnace atmosphere contributed to NO_x formation in addition to the niter, though the contribution of this outside air to NO_x is not known. Nevertheless, these tests on an actual operating furnace showed NO_x reductions of 86 to 90 percent from baseline levels using oxy-firing (from 21.6 to 2.9 and 2.1 lb/ton, respectively, for the two oxy-firing tests). A later test at a 100 ton/day container glass furnace with less air infiltration and which did not contain substantial niter gave NO_x emissions of less than 0.2 lb NO_x/ton glass produced (<0.05 lb NO_x/MM Btu).⁶² This is consistent with values expected from Figure 5-14.

Corning, working with Linde Division of Union Carbide (now Praxair), has converted 34 of its furnaces to oxy-firing as well as the Gallo plant in California.^{38,63} "80-plus" percent NO_x reduction with oxy-firing, presumably representative of the 34 furnaces installed as of 1991 has been reported.³⁸ The Gallo plant reports 84 percent reduction in NO_x (from 5.03 to 0.81 lb NO_x/ton of glass corresponding to a reduction in NO_x from 1.34 to 0.24 lb NO_x/MM Btu⁶⁴ and is the largest oxy-fired glass furnace reported as of 1991 (400 ton/day, 1248 ft²). Related work showed NO_x generation as 0.3 lb NO_x/MM Btu corresponding to around 1.8 lb NO_x/ton glass, assuming 6 MM Btu/ton of glass.⁶⁴ A general value of less than 2 lb/ton for oxy firing has been estimated.⁶⁵ Table 5-6 summarizes the reported NO_x emissions reductions discussed above.

5.3 PROCESS MODIFICATIONS

Process modifications include changes to the furnace, its combustion system, or its heat recovery system that have the effect of lowering either the NO_x emission rate (lb NO_x/hr) or normalized NO_x emissions (lb NO_x/ton of glass produced). In many cases, such modifications are designed to increase furnace productivity (tons glass produced/hr) with lower NO_x emissions being an unintended benefit.⁶⁸ This is the case for the three process modifications considered here.

5.3.1 Modified Furnace

5.3.1.1 Teichmann System. Teichmann/Sorg Group, Ltd., has developed an LoNO_x[™] furnace that incorporates cullet preheating using furnace exhaust gas into a modified melter design that also uses lower than normal combustion air preheat.⁶⁹⁻⁷¹ The basic furnace design is shown in Figure 5-15. The combustion air and fuel are preheated in the convection recuperator section. The combustion takes place in eight burners, four on each side. The exhaust gas passes over the melt, heating it, and exits

TABLE 5-6. NO_x EMISSIONS FROM OXY-FIRING

Site	Furnace pull (ton/day)	Baseline NO _x emissions			Controlled NO _x emissions			NO _x reduction from baseline	Reference
		lb/ton	lb/MM Btu	lb/ton	lb/MM Btu	lb/ton	lb/MM Btu		
Gallo	338	5.03	1.34 ^a	0.81	0.24 ^a	0.81	0.24 ^a	84%	38
not disclosed	75	21.6	4.28	2.1	0.50	2.1	0.50	90%	54
not disclosed	100	NR	NR	<0.2	0.05	<0.2	0.05	—	54
not disclosed		NR	3.0 ^b	NR	0.3	NR	0.3	90% ^b	64

^a Calculated from data given by Moore and Brown.⁶⁶ This furnace has electric boost of about 14% of the total energy input and this is not accounted for in calculating these values of NO_x emissions.

^b Brown provides unsupported data claiming that the measured value of 0.3 lb/MM Btu is "... 90% less than predicted or measured on similar regenerative furnaces."⁶⁷ Baseline emissions are not provided, but a value of 3.0 lb/MM Btu can be calculated from the above.

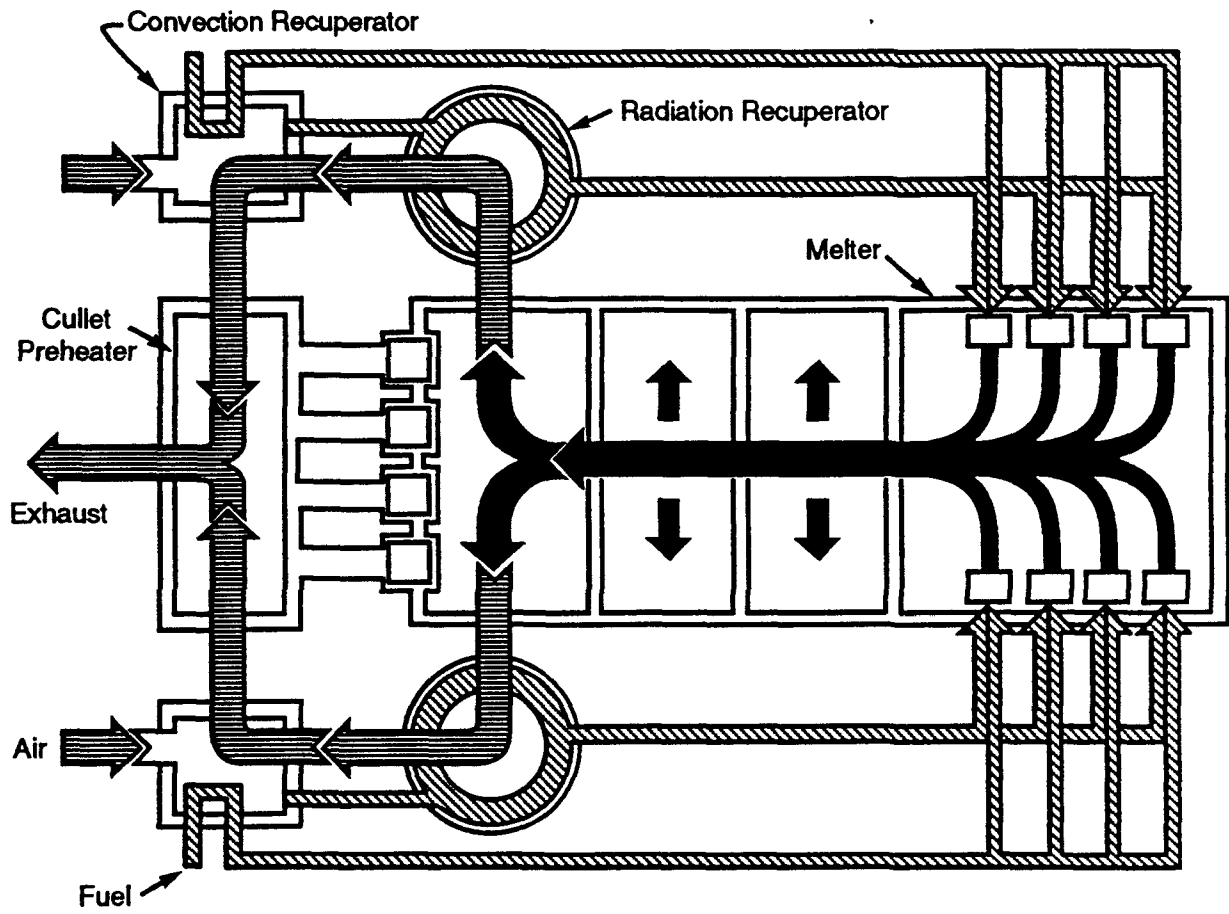

Figure 5-15. General arrangement of Teichmann/Sorg LoNO_x™ furnace.^{70,71}

each side. It then passes upward through parallel radiation recuperators, turns downward, and passes through the convection recuperators. From there, the exhaust gas enters a crossflow cullet preheater and finally exhausts through the stack (Figure 5-16). An energy balance on the preheater itself is shown schematically in Figure 5-17.⁷²

The combustion air is preheated to only about 700 °C (1,290 °F), about 550 °C (990 °F) lower than an efficient regenerative furnace.^{70,73} This lower preheat would be expected to require a higher input of fuel to achieve the same furnace temperature, resulting in higher normalized NO_x emissions (lb NO_x per ton of glass produced). However, this is more than compensated for by the heat recovery in the two recuperators. This furnace also uses electrical boost (Section 5.3.2), with nine electrodes inserted in the preheating end to control the glass temperature and viscosity. This electrical boosting reduces NO_x emissions since electrical energy is substituted for thermal energy in the fuel.

The initial installation of this LoNO_x[™] furnace was a 200 ton/day, natural gas-fired container glass furnace which began operation at Weigand Glass in Steinbach, Germany, in 1987. A second one, 300 ton/day, has been ordered for the same plant and is under construction.⁷¹ The first furnace operates with a batch of 80 percent cullet, resulting in an energy consumption of 3.1×10^6 Btu/ton, about half that shown in Chapter 3 for virgin batch materials. Design calculations show that at 30 percent cullet, the energy consumption would be about 3.4×10^6 Btu/ton.⁷⁴ Table 5-7 shows the NO_x emissions over a 6-month period shortly after startup.⁷⁵ These are at a somewhat less than design glass production rate, 170 ton/day versus 220 ton/day design, and the normalized emissions, lb NO_x per ton of glass, would presumably be lower at design capacity. The results show emissions of less than 1.45 lb NO_x/ton glass.

5.3.2 Cullet/Batch Preheat

Chapter 3 describes the inherent thermal inefficiency of the glass melting operation, with roughly one-third of the energy input being lost in the flue gas. This is the basic reason for the development of cullet preheat systems, which, to date, have been demonstrated only in container glass production. If some of this energy is recovered, less fuel is needed to produce a given quantity of glass and the normalized NO_x emissions (lb NO_x/ton glass) are reduced. Reductions in NO_x emissions are directly proportional to the lower fuel requirements—if a cullet preheater reduces fuel usage by 10 percent, NO_x (lb NO_x/ton glass) should decrease by 10 percent, all else being equal. Two different process configurations have been developed.

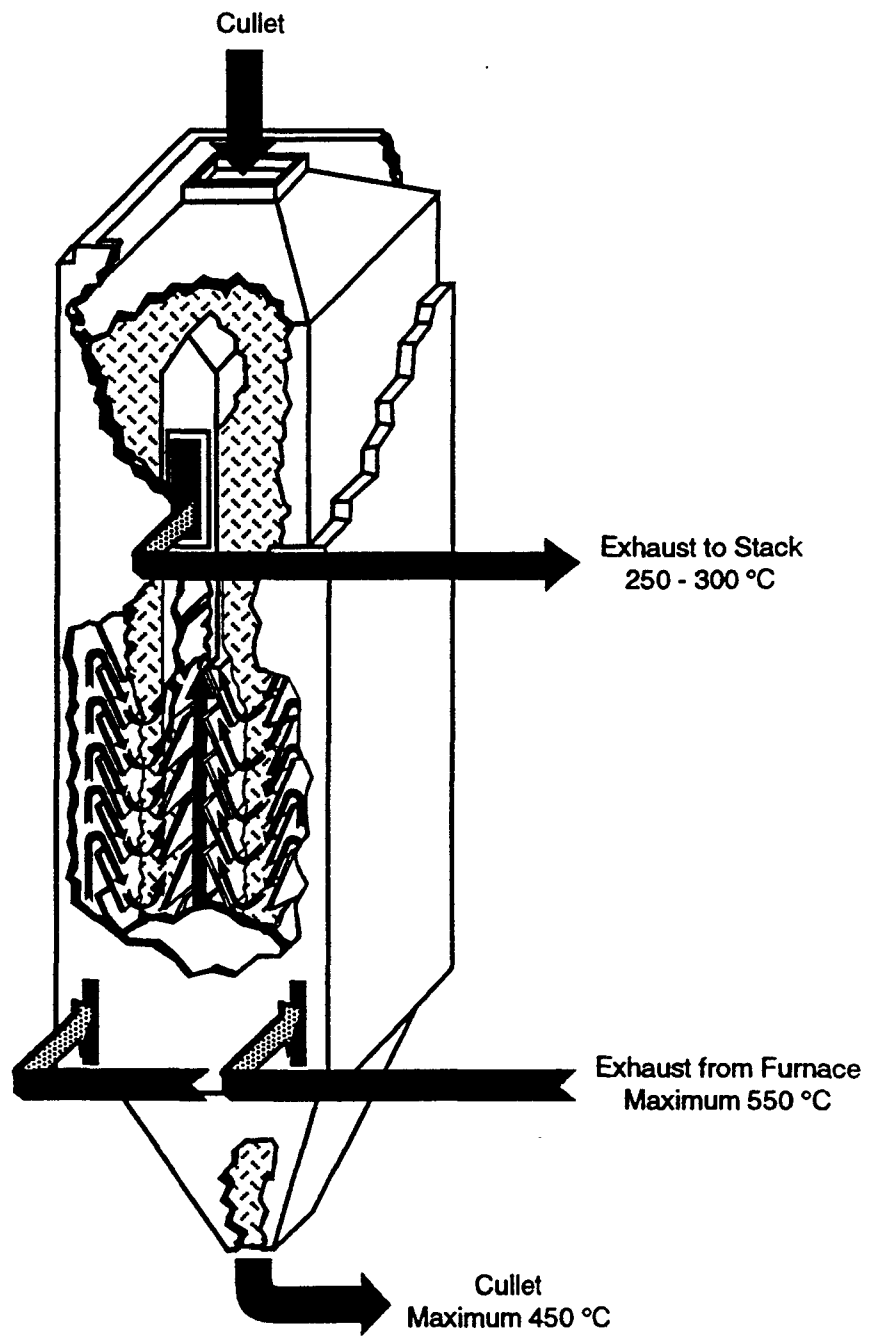

Figure 5-16. Crossflow cullet preheater.^{70,71}

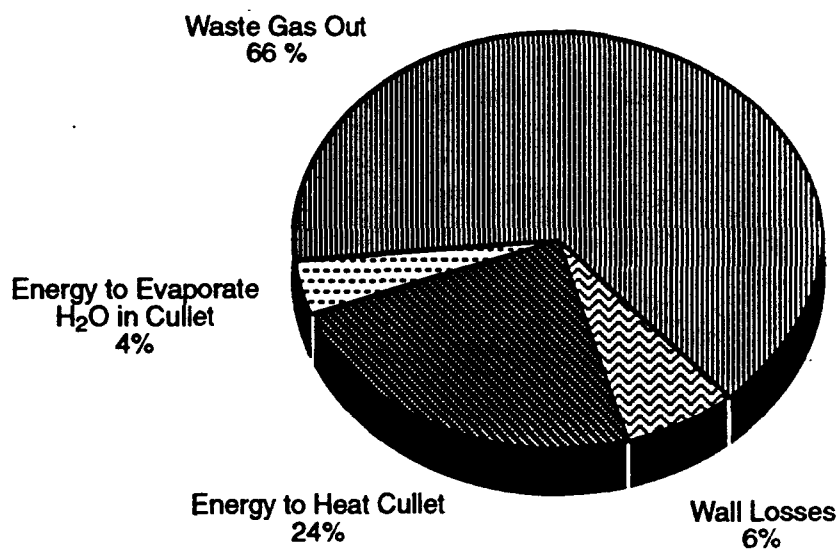

Figure 5-17. Cullet preheater energy balance.^{70,71}

TABLE 5-7. NO_x EMISSIONS FOR FURNACE WITH TEICHMANN LoNO_x™ FURNACE⁷⁵

Date	Tons/day ^a	mg/nM ³ Corr. 8% O ₂	NO _x		
			kg/hr	lb/hr	lb/ton
Spring 1988	169	400	3.31	7.29	1.02
Fall 1988	178	412	4.9	10.8	1.45
Summer 1989	195	421	5.3	11.7	1.44

^a This is reported as "M. tons per day," which is assumed to be metric ton per day. The numbers reported as such by Moore have been put, above, into English "tons."

5.3.2.1 Tecogen System. A cullet preheat system developed by Tecogen, Inc. (Waltham, MA) operates in a different way from that shown in Figure 5-15. As shown in Figure 5-15, rather than using the sensible heat of the exhaust gases from the melting furnace, the cullet preheater itself has small dual natural gas burners (total capacity 2 MM Btu/hr) to preheat the cullet (Figure 5-18).⁷⁶ In effect, this allows some of the fuel that would otherwise be needed in the melting furnace to be burned at lower temperatures, resulting in lower NO_x emissions for the same energy input. An earlier version of this system shows a slightly different arrangement of this preheater.⁷⁷ The principle of operation is that heat is transferred from the upward flowing natural gas burner exhaust gases to the downward flowing cullet. The cullet is preheated to 205 to 260 °C (400 to 500 °F).⁷⁸ Unlike the LoNO_x[™] melter described above, this system is not an integral part of the furnace design and could presumably be more easily retrofit. Figure 5-19 shows the increase in furnace production as a function of percent cullet in the batch (these are calculated numbers, not test results).

This system was installed at the Foster Forbes container glass plant in Milford, MA, producing 240 ton/day and was tested over a 5-day period in 1989.⁷⁹ The cullet preheater was designed to preheat 20 to 100 ton/day, but was operated between 12 and 78 ton/day for these tests.⁸⁰ This corresponds to between 5 and 30 percent of the batch as cullet (accounting for 10 percent loss from batch to final product; i.e., 264 ton/day of batch ingredients is needed to produce 240 ton/day of glass). The results of this test showed that the specific energy use (MM Btu/ton glass produced) declined about 7 percent. All other factors being equal, this would correspond to about a 7 percent reduction in normalized NO_x emissions (lb NO_x/ton glass produced). Calculated curves of the *expected* reduction in normalized NO_x emissions as a function of percent cullet in the batch are shown in Figure 5-20 for a cullet preheat temperature of 480 °C (900 °F).⁸¹ As expected, the higher the proportion of cullet, the higher the *reduction* in NO_x emissions.

Earlier results from a 1987 test of 1670 hrs on a slightly different configuration of the preheater (compare Figures 5-21 and 5-26) were made using higher cullet preheat temperatures, around 455 to 516 °C (850 to 960 °F).^{82,83} Important differences in these two preheaters include the use of natural gas burners, the apparent lack of mechanical support for the cullet in Figure 5-18, the use of regenerator offgas, and a moving grate in Figure 5-21. These tests were also done at the Foster Forbes plant. The

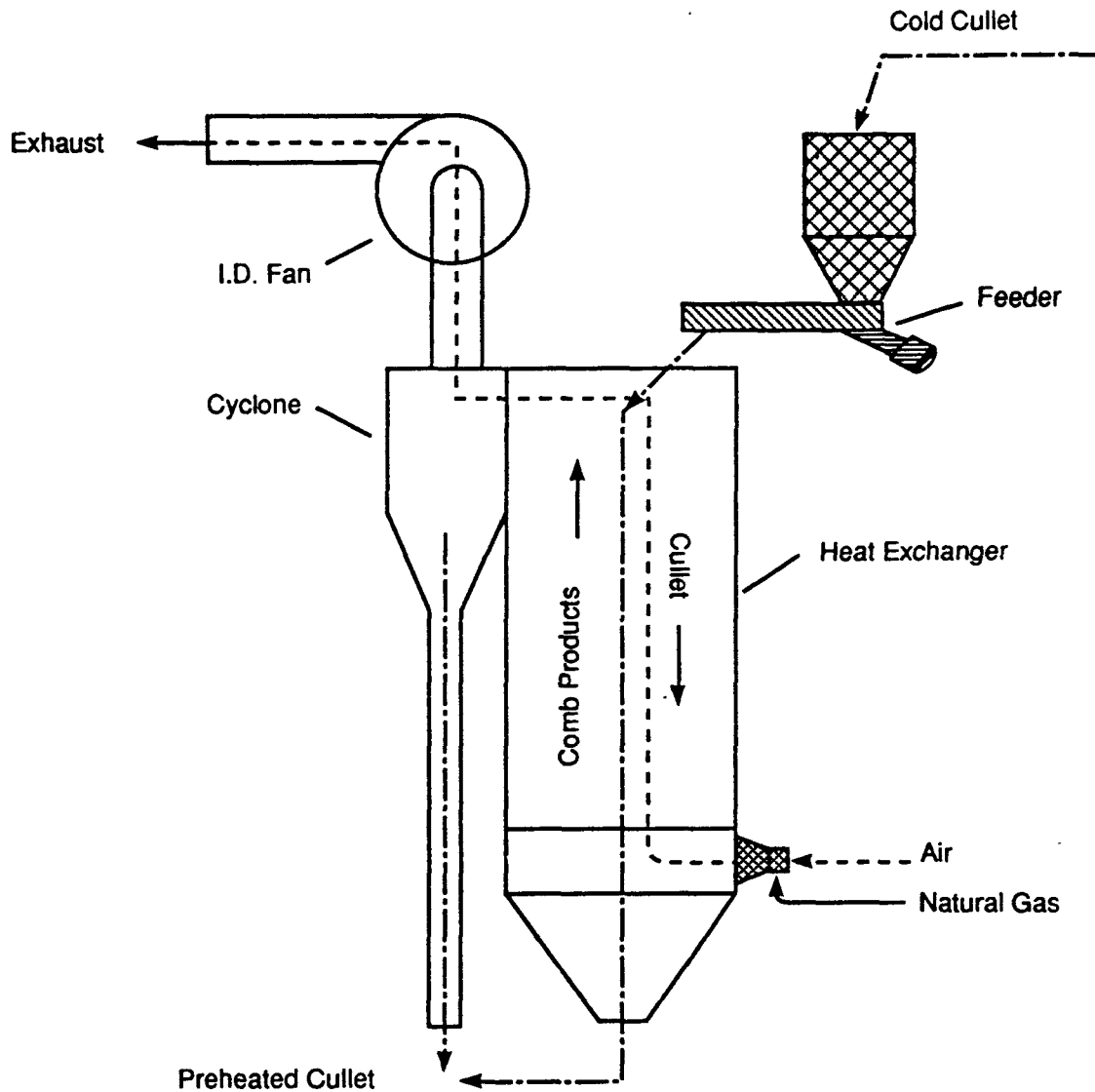

Figure 5-18. Cullet preheater concept by Tecogen.⁷⁶

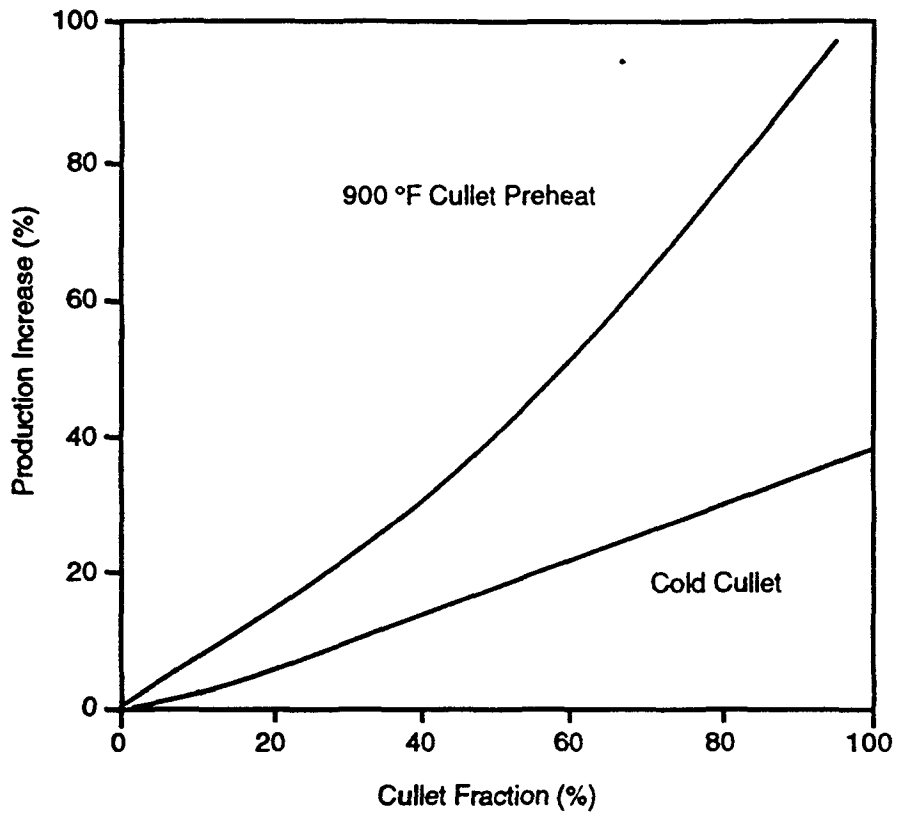

Figure 5-19. Production increase available with preheated cullet.⁷⁹

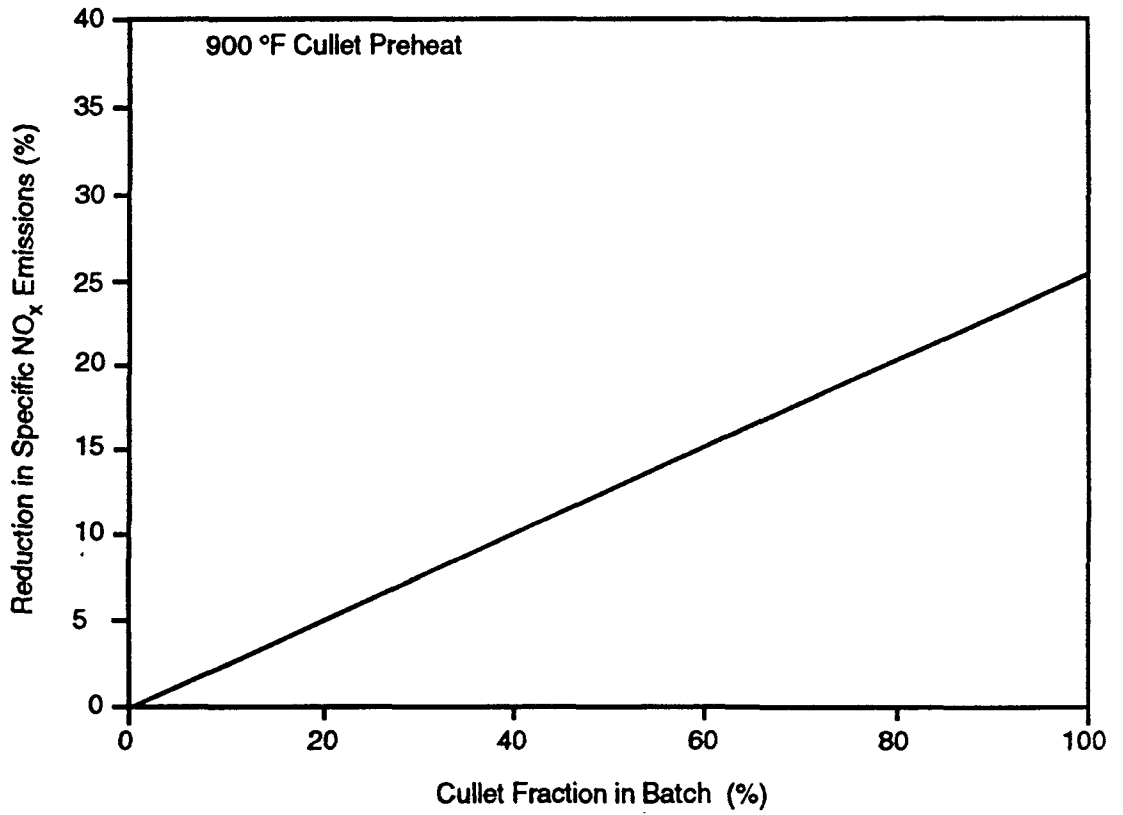

Figure 5-20. Reduction in specific NO_x emissions with cullet preheat.⁷⁹

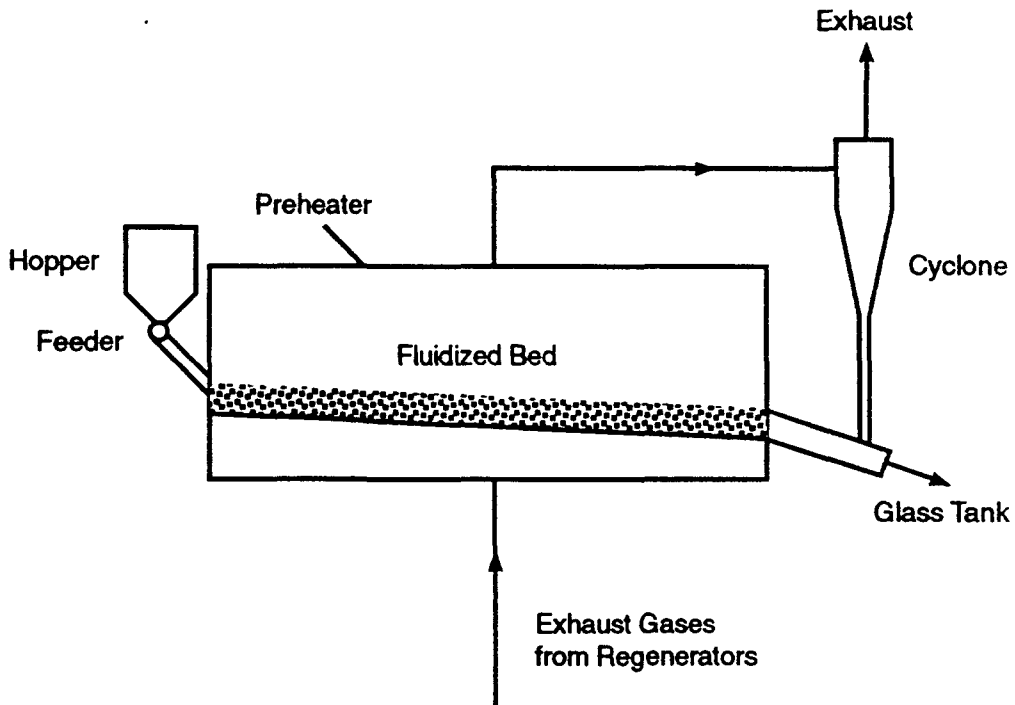
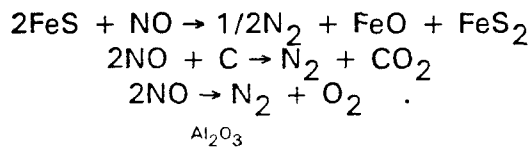

Figure 5-21. Fluidized-bed glass batch preheater.

unit was apparently designed to preheat not only cullet but the entire batch, using exhaust flue gases from the regenerator rather than independent natural gas burners for preheating only cullet. Tests were made at preheater throughputs from 90 to 225 ton/day on an end-port fired, natural gas-fired furnace. This plant has an interruptible gas supply and burns heavy fuel oil in the winter months.⁸³ Figure 5-22 shows the installation. The preheater design throughput was 165 tons/day, although it achieved a rate of 225 tons/day for one 8-hr period.

The results of the tests showed a 7 to 8 percent less net energy usage rate when the preheater was operated near its design capacity.⁸⁴ Apparently only about 30 percent (4, 400 scfm) of the flue gas was recycled to the preheater since this was all that was needed for the preheater to function at design capacity.⁸⁵ Measurements of the gases from the preheater alone showed that the NO_x emissions were about 0.58 lb NO_x/ton glass.⁸⁶ This unexpectedly low value was attributed to the reaction of NO in the flue gas with ingredients in the batch, e.g.,



The first two reactions are simply gas-solid reactions in which NO is reduced to N₂ by the FeS and C (carbon) ingredients in the batch. The third is a catalytic reaction in which alumina (Al₂O₃) is said to act as the catalyst. There was no decrease in the glass quality in these tests, suggesting that these reactions do not affect product quality.⁸³ However, "furnace dusting problems," not further described, caused the tests to be discontinued.⁸⁷

Because only 30 percent of the total flue gas from the melting furnace can pass through the preheater, the overall NO_x emissions reduction from the entire furnace is not as great as if all the flue gas went through the preheater. NO_x emissions decreased by 81 percent (from 17.4 to 3.3 lb NO_x/hr) for that part of the overall flue gas passing through the preheater, corresponding to a 24 percent decrease in the overall NO_x emissions (from 58 to 44 lb NO_x/hr) from the furnace. This, in turn, corresponds to a 39 percent decrease in normalized NO_x emissions, from 5.4 to 3.3 lb NO_x/ton of glass produced, from the furnace.⁸⁸

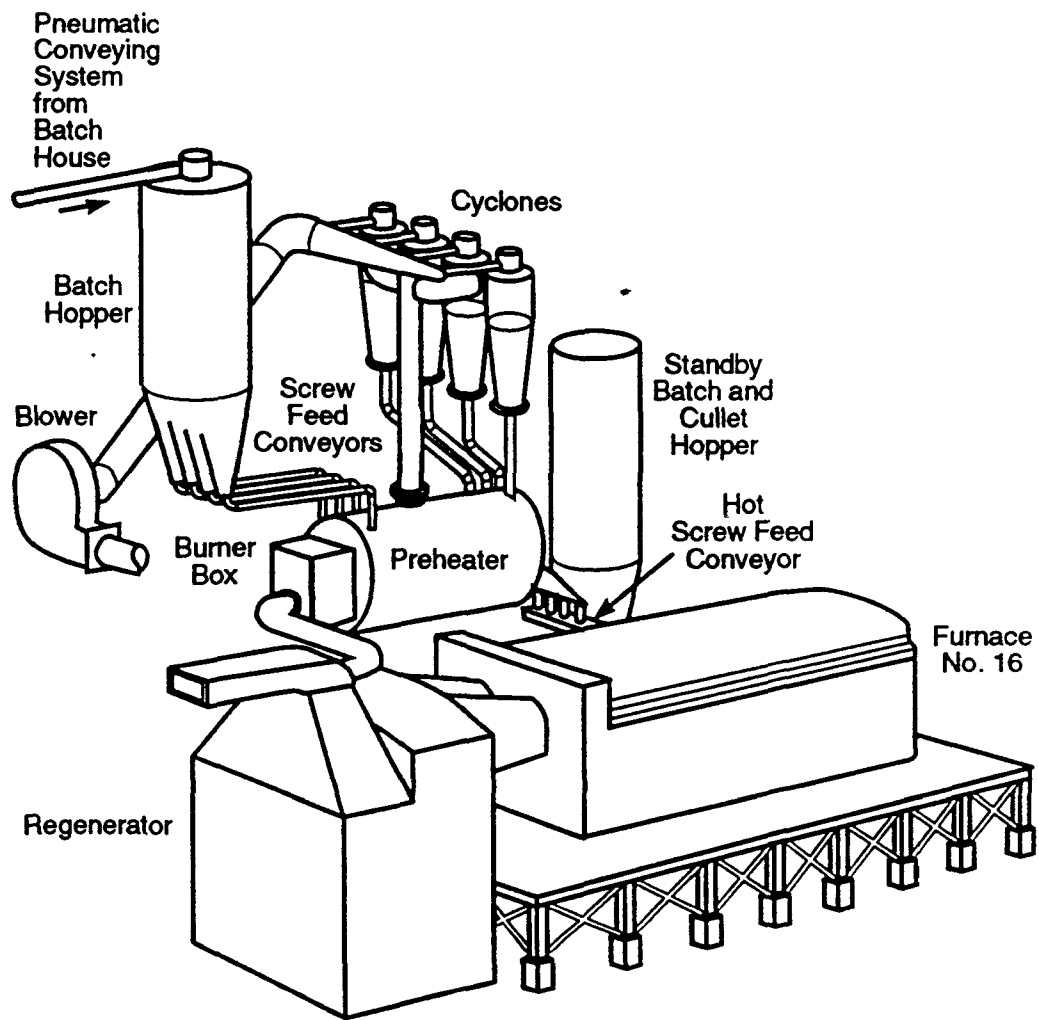

Figure 5-22. The glass batch preheater system installed at Foster Forbes.⁸³

5.3.2.2 Zippe System. A third cullet preheat system by Zippe Industrieanlagen GmbH (Germany) is reported by Zippe.⁸⁹ Units have been installed at two furnaces in Europe, one (Vetropack) producing 300 tons/day using 100 percent cullet feed. On this plant, the preheater is used for at least 50 percent of the total cullet throughput. The unit is a cross-flow countercurrent heat exchanger in which, unlike the Teichmanm and Tecogen systems, the cullet is heated indirectly. The cullet flow inside the preheater is by gravity. After passing through the preheater, the cullet is conveyed by a vibrating tray to the batch charger. The speed of the material through the preheater is about 6 to 12 ft/hr. Flue gas at around 550 °C (1,020 °F) is used to heat the cullet from ambient to 300 to 350 °C (570 to 660 °F). Apparently, natural gas burners can also be used. No information is provided on NO_x reduction, though *calculations* shows energy consumption would be reduced by 12 percent if all the cullet at Vetropack were preheated. Assuming all other process conditions are constant, this would correspond to a 12 percent decrease in normalized NO_x emissions (lb NO_x/ton of glass produced). A second system has been installed at a 300 ton/day end-fired container glass furnace.⁹⁰ The preheater is used for all melting material, which consists of 70 percent cullet and 30 percent batch.

5.3.2.3 Nienburger System. A third cullet/batch preheat system (Figure 5-23) has been demonstrated in Germany by Nienburger Glas GmbH on two container glass furnaces.⁹⁰ The first installation of this system was in 1987 on a 300 ton/day cross-fired furnace with 80 percent cullet. This furnace operates with 600 to 800 kW electric boost with a specific heat input of 3.2 MM Btu/ton. No information is provided about the heat input without the preheater, which would allow an estimate of NO_x emission reduction. A second furnace was equipped with a batch preheater in March 1991. This is a 350 ton/day cross-fired container glass furnace using 30 to 50 percent cullet. The batch is preheated from ambient temperature to 270 to 290 °C (550 to 590 °F) and the specific heat input was 3.2 MM Btu/ton with no electric boost. Tests without the preheater showed a heat input of 3.8 MM Btu/ton, corresponding to a 20 percent decrease in heat input with the preheater. This corresponds to a 20 percent decrease in NO_x emissions.⁹² An additional decrease in NO_x emissions is claimed due to a reduction in the furnace crown temperature of about 50 to 60 °C (from 1,590 to 1,600 °C to 1,530 to 1,550 °C).⁹² Actual flue gas NO_x concentrations with the preheater are less than 1,490 ppm, corrected to 8 percent O₂, dry, but the corresponding gas flow is not given, so that the calculation of NO_x in lb NO_x/ton glass cannot be made.

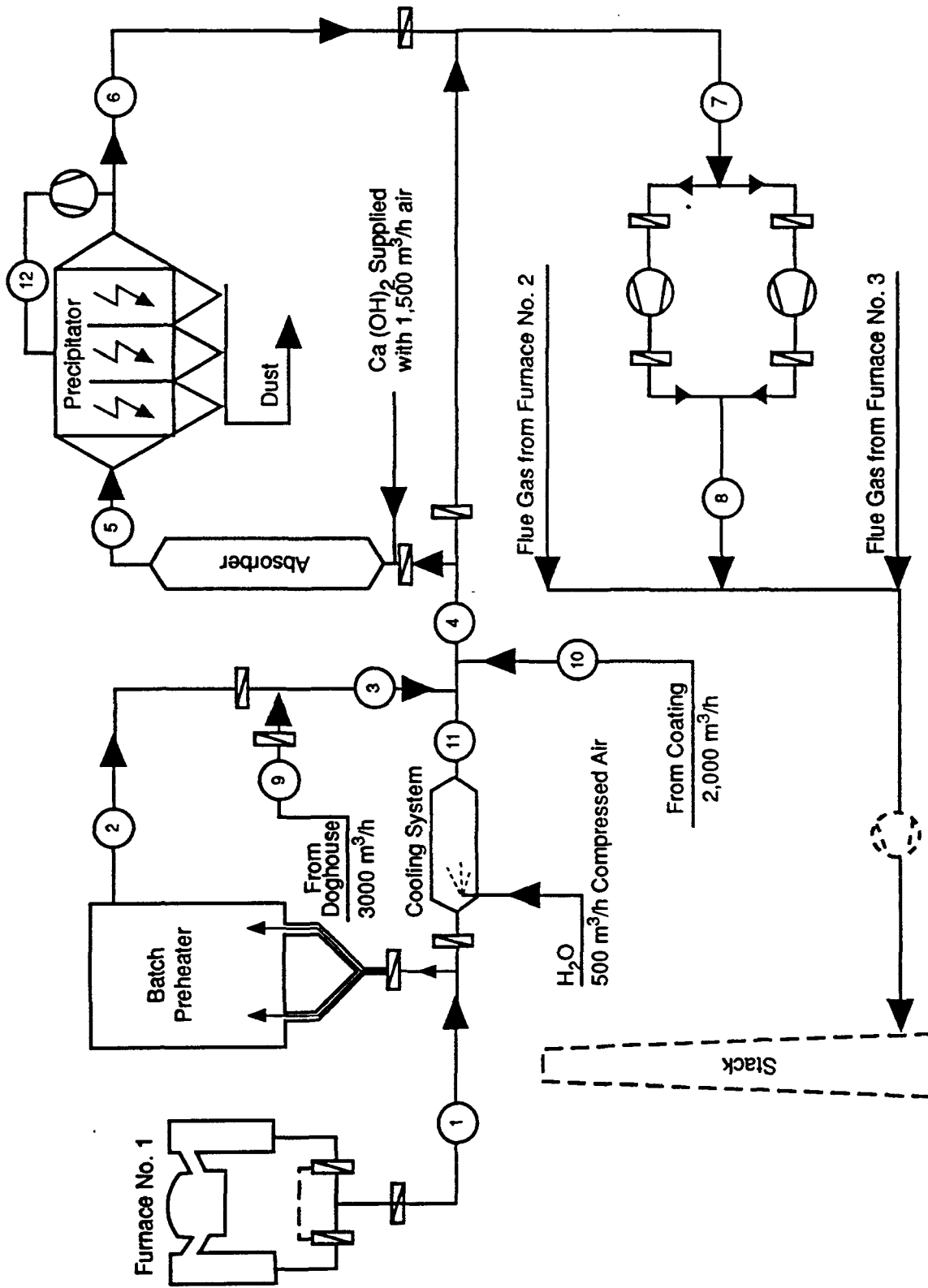

Figure 5-23. Flow diagram of the Nienburger batch preheater.⁹¹

5.3.3 Electric Boost/Electric Melting

Electric boosting is the use of electrical current, passing between electrodes submerged in the glass melt, to resistively heat the batch materials. This is done by placing electrodes, generally made of molybdenum, through the sidewalls or furnace bottom into the glass melt. Because of differences in quality needs, furnace size, and temperature-resistivity relationships for different batch materials, electric boosting is employed only in the container industry.⁹³ At a given glass production rate, electric boost allows a reduction in the furnace temperature and therefore in gas-firing rate and NO_x emissions. Reduction in NO_x emissions is directly proportional to the percent of the furnace energy supplied electrically.⁹⁴

Electric boost is common in container glass furnaces and in some pressed/blown furnaces. However, it is not now used in float glass furnaces because of problems related to productivity, sidewall erosion, glass quality, and furnace campaign life.⁹⁵ A 1989 survey for GRI of 41 glass melting companies, including some of the largest manufacturers presented in Chapter 4, showed that 60 percent of these companies use electric boosting in their process.⁹⁶ These 41 respondents represent 90 percent of the glass produced per year in the United States by weight.⁹⁷ The reason for electric boosting is often to increase furnace production (ton glass produced/day) without adding an additional furnace or otherwise modifying an existing one. There are also certain areas of the country where business arrangements with gas and electric companies make electric boosting favorable.

The effect of electric boosting on NO_x emissions was studied on container glass, side port furnaces from 400 to 1200 ft² in size.⁹⁸ Figure 5-24 shows the reduction in NO_x emissions (lb NO_x/hr) as a function of furnace production rate (ton glass produced per day). This figure compares actual (points) and predicted (lines) values for NO_x emissions. Electrical boost appears to lower NO_x emissions, as expected (e.g., compare the two data points at 275 tons/day for 700 kW and 950 kW of boost), though the predictions (lines) are inaccurate. The increase in the NO_x emission rate in going from no boost (~60 lb NO_x/hr at 220 tons/day) to 700 kW (~75 lb NO_x/hr at 280 tons/day) actually corresponds to a slight decrease in normalized NO_x emissions from 6.5 lb NO_x/ton of glass with no boost to 6.4 lb NO_x/ton with 700 kW boost. Figure 5-24 shows that the use of 950 kW boost permitted the furnace throughput to increase from 220 tons/day (with no boost) to 280 tons/day with an actual decrease in NO_x emissions from 60 lb/hr to 40 lb/hr (corresponding to a reduction from 6.55 lb NO_x/ton at 220 tons/day to 3.43 lb NO_x/ton at

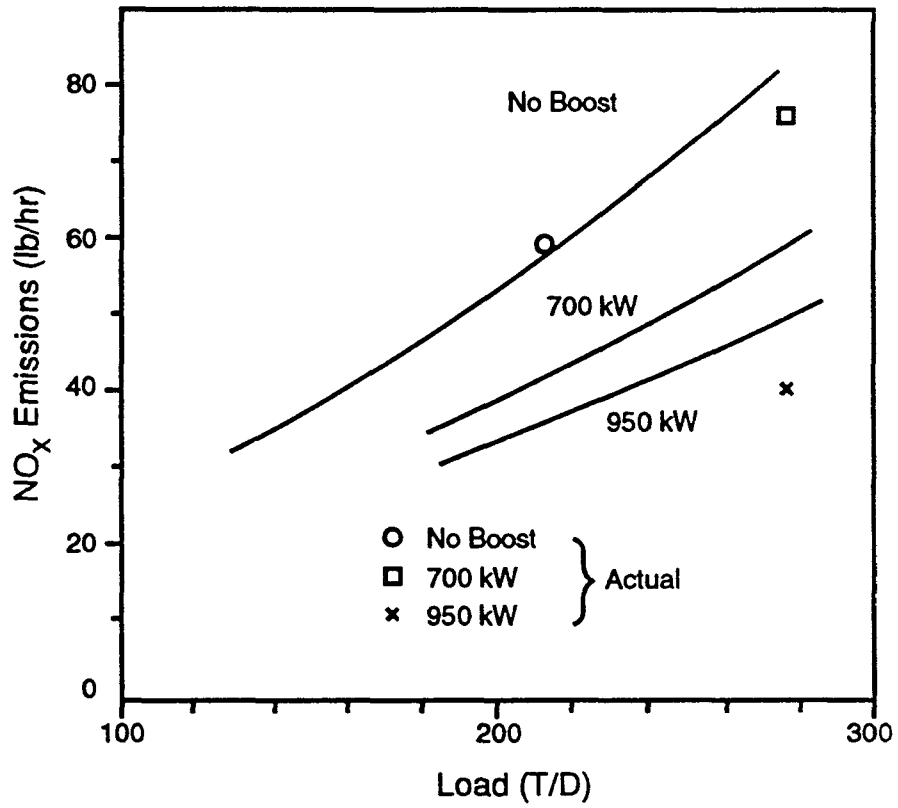

Figure 5-24. Rate of NO_x emissions versus load for 928 ft² amber glass furnace.⁹⁴

280 tons/day).⁹⁹ An equivalence between electric boost and glass production is estimated to be 25 tons of glass/day per 1000 kVA (or 1 ton glass per 800 kWh).¹⁰⁰ As discussed in Section 5.3.2, electric boost is more efficient than gas firing, i.e., more of the theoretical energy input to the melt electrically is actually transferred to the melt. This efficiency value for electric boost is 73 percent compared to about 30 to 35 percent for gas firing¹⁰¹ (see Section 3.2). However, the production and distribution of electricity from fossil fuels are only about 20 to 25 percent efficient, making electricity from fossil fuels less efficient than gas firing.

Of course, all-electric melting is simply a logical extension of electric boost. All electric melters, however, are limited by current technology to furnaces that are smaller (roughly half the size) of conventional gas-fired furnaces for container glass production.

Only 3 percent of respondents in the 1989 GRI study use electric furnaces solely for their melting.¹⁰² An all-electric melter was installed at the Gallo Glass Company (Modesto, CA) in 1982.¹⁰³ Its design capacity was 162 tons/day. Average energy consumption was 880 kWh, corresponding to 3 MM Btu/ton. Energy efficiency was 73 percent (i.e., 880 kWh/ton was input as electrical energy to melt a batch formulation with a theoretical melting energy requirement of 645 kWh/ton). As expected, this energy consumption gradually increased with time to maintain a constant production rate.¹⁰³ Glass quality was acceptable and the furnace was operated over a 3-year campaign before being rebuilt.¹⁰⁴ Furnace campaign life is typically longer than this for gas-fired furnaces, e.g., 8 to 12 years for flat glass furnaces. Of course, there are no NO_x emissions directly from this all-electric melter. NO_x would be generated, indirectly, if fossil fuels are used in the production of electricity.

5.4 POSTCOMBUSTION MODIFICATIONS

5.4.1 Selective Catalytic Reduction (SCR)

SCR is the reaction of ammonia (NH₃) with NO_x to produce nitrogen (N₂) and water vapor (H₂O). The two principal reactions are:

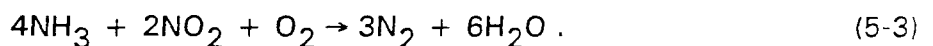
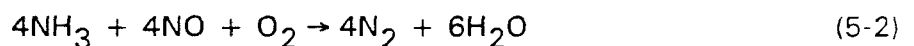

Reaction (5-2) is the reduction of NO, Reaction (5-3) the reduction of NO₂. Reaction (5-2) is by far the most important since 90 to 95 percent of the NO_x in the flue gas is NO. To achieve reaction rates of practical interest, a catalyst is used to promote the reaction at

temperatures of around 300 to 450 °C, (570 to 840 °F) which may be somewhat lower than those in the flue gas of a glass furnace. Relatively new zeolite-based catalysts can be used at temperatures more typical of glass furnace flue gas (500 to 550 °C).¹⁰⁵

In practice, an NH₃/NO mol ratio of 1.05-1.1/1 is used to obtain NO_x conversion of 80 to 90 percent with a "slip" of unreacted ammonia downstream of the catalyst of about 20 ppm.¹⁰⁶ The catalyst is typically a mixture of vanadium and titanium oxides supported on a ceramic monolith, as shown in Figure 5-25.

SCR units have been installed on a number of utility boilers, gas turbines, internal combustion engines, and process heaters, and SCR is considered commercially demonstrated. As of late 1992, there are no reported operating SCR installations on glass furnaces in the United States; however, SCR units have been reported on container glass plants in Europe. Oberland Glas (Neuberg plant, Germany) reported the installation of an "SCR-DeNO_x" unit on their glass melter flue gas, but few details are provided beyond problems with fouling of the catalyst by particulates.¹⁰⁸ The flue gas is treated in three consecutive steps:

- Adsorption of acidic compounds by hydrated lime injection,
- Particulate removal, including reacted lime, and
- SCR.

The unit was started up in October 1987 and achieves a reported 80 percent reduction of NO_x, from 1,420 ppm to 283 ppm.¹⁰⁹ The flue gas flow rate is 35,300 scfm and the operating temperature is 350 °C (660 °F).

A higher temperature zeolite-based SCR process called "CER-NO_x" is used on a 500 tons/day glass furnace in Germany.¹¹⁰ This catalyst is supplied by EESI (La Mirada, CA), apparently under license from Steuler (Germany). About 100 of these SCR units are installed in Europe on processes such as cogeneration and gas turbines. Figure 5-26 shows a schematic of the process, which also includes hydrated lime injection and an electrostatic precipitator upstream of the SCR unit. The SCR unit treats flue gases from three glass furnaces using a 25 percent aqueous ammonia injection system (rather than gaseous anhydrous NH₃ used in some other SCR units).

The process achieves a reported 80 percent reduction of NO_x emissions (from 925 to 195 ppm) at 10 to 30 ppm ammonia slip. The flue gas flow rate is 29,500 scfm and the inlet temperature to the SCR unit is around 175 °C (350 °F). This temperature is somewhat lower than other glass furnace flue gas temperatures because of the injection of

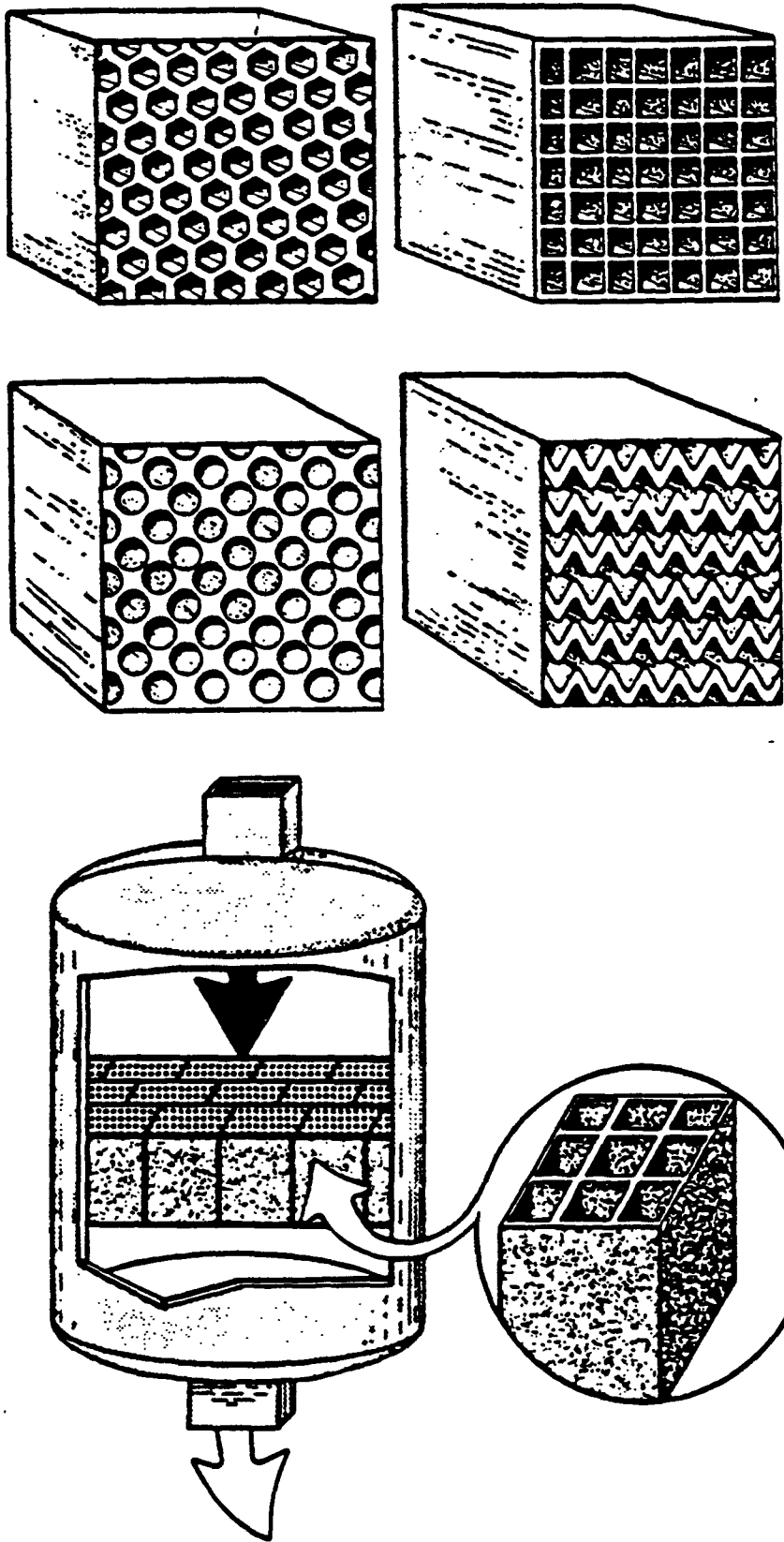

Figure 5-25. Unit cell detail of a monolith SCR catalyst.¹⁰⁷

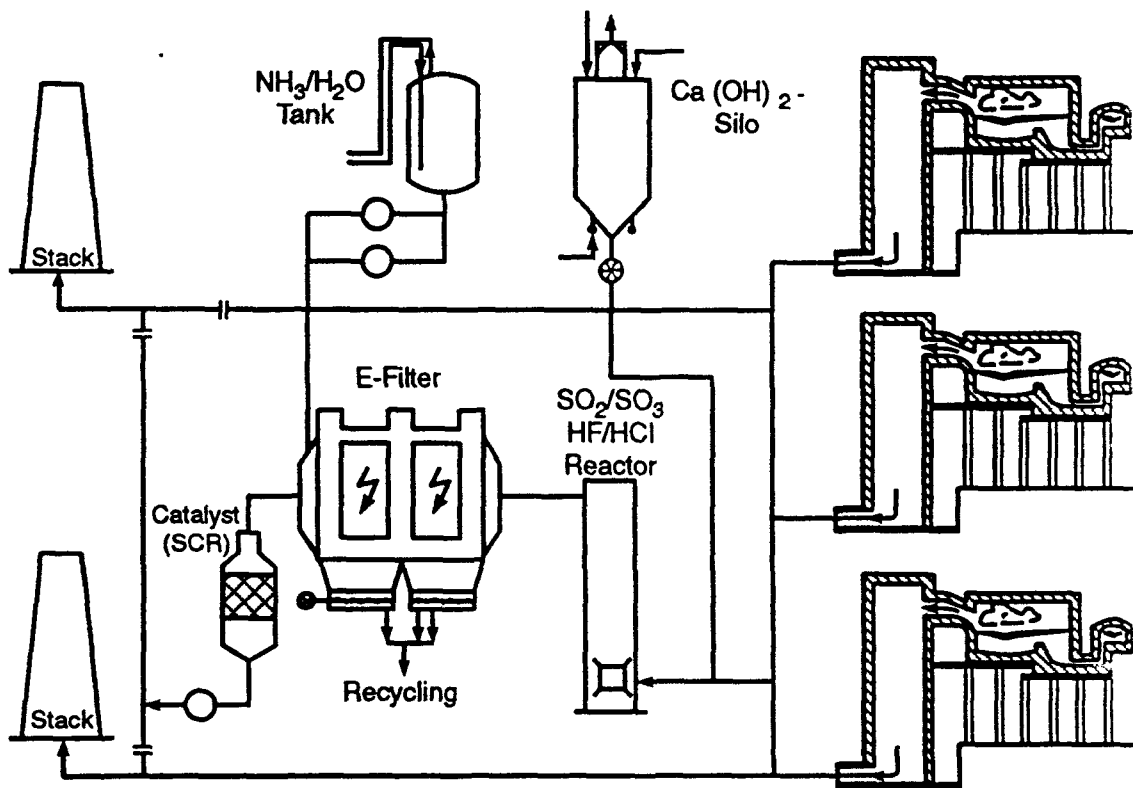

Figure 5.26. Installation of SCR unit on glass furnace.¹¹⁰

hydrated lime upstream of the SCR unit. Using these values, and a reported furnace production of 500 ton/day of glass, the NO_x emission reduction (" NO_x " is calculated by the authors as NO_2) can be calculated as being from 10.1 to 2.1 lb NO_x /ton glass produced (i.e., from 1.68 to 0.35 lb NO_x /ton glass, assuming 6 MM Btu/ton glass). As with the Oberland Glas installation, accumulation of fine dust covered the catalyst shortly after startup even though there was an electrostatic precipitator upstream of the SCR catalyst and the SCR NO_x reduction decreased. A pulsing blower and steel facings were installed in front of the catalyst to minimize dust accumulation. No information is given as to how successful this was. The dust accumulation is likely to make the application of SCR to glass furnaces doubtful, although Lurgi (Frankfurt, Germany) reports the development of a soot blower to remove dust from the SCR catalyst surface.¹¹¹ A unit has been installed and tested on a Schott Glaswerk specialty glass furnace in Mainz, Germany. NO_x emissions were reduced by 70 percent. The flue gas flow rate is 29,400 scfm and the SCR unit operates at 300 to 400 °C (570 to 750 °F).¹¹¹

5.4.2 Selective Noncatalytic Reduction (SNCR)

Selective noncatalytic reduction is the reaction of ammonia or urea with NO, via the same type of reactions as shown in Section 5.4.1 for SCR, without the use of a catalyst. These processes do not reduce NO_2 . In principle, any of a number of nitrogen compounds can be used to reduce NO to N_2 and H_2O by similar reactions. These compounds include cyanuric acid, pyridine, ammonium acetate, and others. However, for reasons of cost, safety, simplicity, and byproduct formation, ammonia and urea have found the most widespread application.

Because no catalyst is used to increase the reaction rate, SNCR is carried out at high temperatures just downstream of the flame. The homogeneous gas phase reaction of ammonia with NO must take place in a fairly narrow temperature range, roughly 870 to 1090 °C (1600 to 2000 °F). At higher temperatures, the rate of a competing reaction for the direct oxidation of ammonia, which actually *forms* NO ($2\text{NH}_3 + 5/2\text{O}_2 \rightarrow 2\text{NO} + 3\text{H}_2\text{O}$) becomes significant. At lower temperatures, the rates of the NO reduction reactions become too slow and unreacted ammonia is present in the flue gas. One modification of this process incorporates the addition of hydrogen and other compounds¹¹² to lower (but not widen) the temperature from 870 to 1,090 °C (1,600 to 2,000 °F) to about 705 to 925 °C (1,300 to 1,700 °F).^{113,114} NH_3/NO mol ratios are varied—Reactions (5-2) and (5-3) above suggest at 1.5/1 to 2/1 molar ratio, which is

typical of industrial practice.^{115,116} There are two commercial SNCR processes—the Exxon Thermal DeNO_x[®] which uses ammonia and the Nalco Fuel Tech NO_xOUT[®] which uses a urea-based reagent. In addition, PPG has patented its own SNCR design.¹¹⁷

Figure 5-27 shows a schematic of the PPG system, which is similar, at least in principle, to the other SNCR systems. Ammonia is injected from nozzles into the flowing gas, as shown in Figure 5-27 for a utility boiler. Because the reaction takes place in the gas phase, SNCR is particularly suitable to gases from glass furnaces containing particles that would foul the catalyst in an SCR system.

The Exxon SNCR process has been installed on over 130 combustion processes worldwide between 1975 and 1993,¹¹⁸⁻¹²⁰ including at least four flat glass furnaces, one German recuperative glass furnace, and three direct-fired furnaces with H₂ addition capability. Although originally designed to use anhydrous ammonia, concerns about safety and the need for high-pressure storage has led to the development of a process using aqueous ammonia.¹¹⁷ However, this aqueous ammonia process apparently has not been used in glass furnaces.

An SNCR process using aqueous urea [CO(NH₂)₂] rather than ammonia was developed by EPRI and is now marketed by Nalco Fuel Tech under the name NO_xOUT[®]. The exact reaction mechanism is not understood, but it probably involves the decomposition of urea, with the subsequent reaction of NH₂ groups with NO¹²¹:

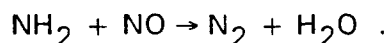

Urea is somewhat safer to handle than anhydrous ammonia, though aqueous ammonia can now be used in the Exxon process. As a more recently developed process, there are somewhat fewer NO_xOUT[®] installations; Nalco claims 70 commercially contracted systems worldwide.¹²²⁻¹²⁴ None of these are reported as being installed on container, flat, or pressed/blown glass furnaces. As with ammonia injection, urea injection must occur in a well-defined temperature window, which is approximately the same as for ammonia injection, 870 to 1,090 °C (1,600 to 2,000 °F).¹²⁵ Others state that wider temperature ranges can be used, presumably due to proprietary additives developed by Nalco.^{8,126-128} NO_x reductions are also comparable to Thermal DeNO_x[®], i.e., around 30 to 60 percent with ammonia slip of 5 to 20 ppm,^{126,129} though reductions of up to 80 percent from uncontrolled levels are reported.¹²⁸ One recent modification of the urea-based SNCR system is the addition of methanol injection downstream of the urea injection point to improve overall NO_x removal. Nalco also recently introduced NO_xOUT PLUS[®],

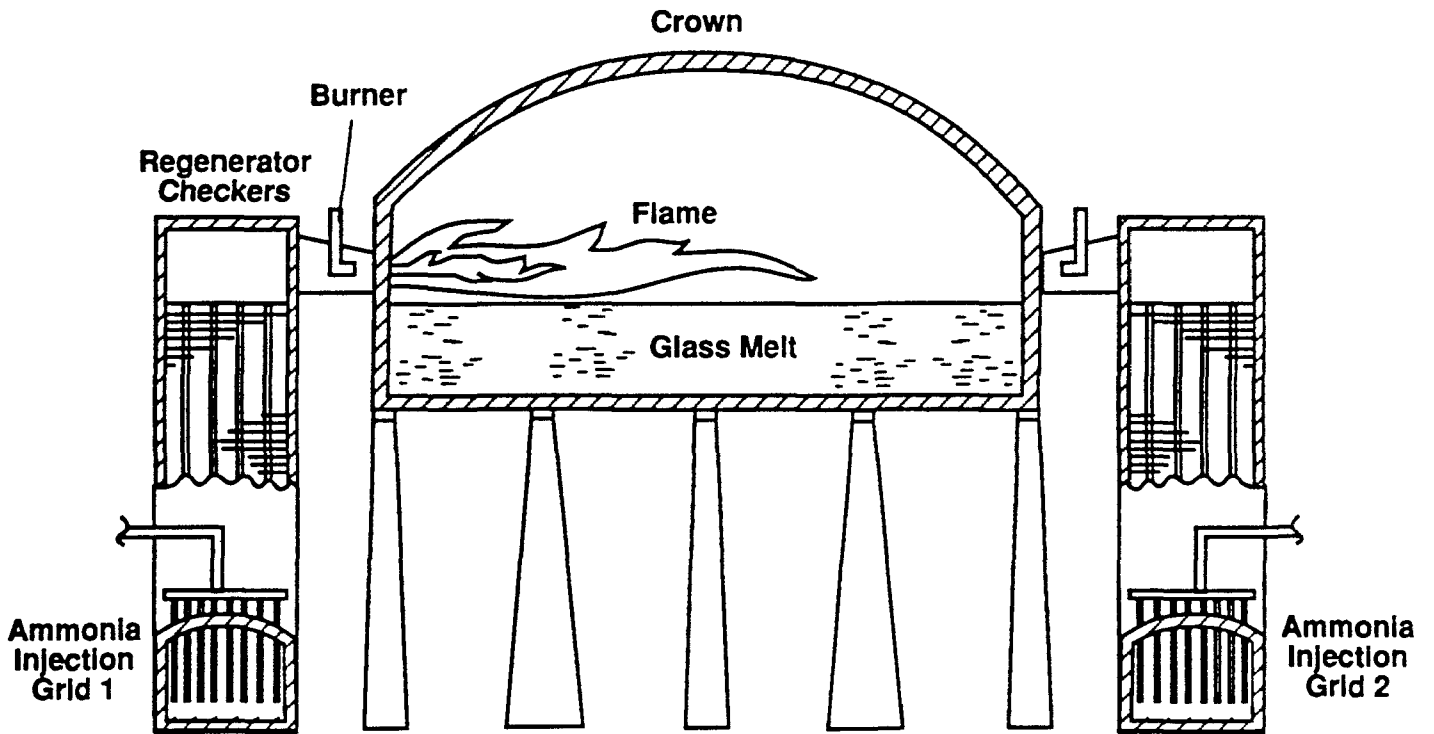

Figure 5-27. PPG SNCR process.¹¹⁷

which is said to broaden the operating temperature window and to reduce ammonia slip and CO and NO₂ formation. Nalco is also developing a combined SNCR/SCR system which reduces SCR costs by decreasing the size of the catalyst and is expected to achieve NO_x reductions similar to SCR alone.

Table 5-8 shows the current SNCR installations on glass melting furnaces for container, flat, and pressed/blown.^{119,120} Actual data on SNCR operating experience for glass furnaces is limited to the PPG (Fresno, CA), LOF (Lathrop, CA), and AFG (Victorville, CA) flat glass plants. As expected, NO_x reduction is highly dependent on furnace-specific factors. The PPG plant installed an Exxon De-NO_x[®] process in 1981 that was later modified to one of their own design.¹¹⁷ Though this process uses ammonia injection, some details are proprietary. NO_x reductions for two tests are from 23.6 and 22.3 to 11.7 and 9.2 lb NO_x/ton glass, respectively. This corresponds to *actual* reductions of 50 and 59 percent for these two tests.

The LOF plant (Lathrop, CA) installed an SNCR system in 1987. The design emission reduction was 56 percent.¹³¹ However, LOF intentionally operates the system to achieve a NO_x reduction of 31 percent to achieve emission reduction credits. The controlled NO_x emissions are 9.7 lb NO_x/ton (1991 test) and 12.4 lb NO_x/ton (1992 test).¹³¹

The AFG plant installed an Exxon De-NO_x[®] system in 1987. Two series of tests have since been made with and without ammonia injection, corresponding to controlled and uncontrolled NO_x emissions. In addition, the ammonia injection *rate* was also varied. From uncontrolled levels of 13.1 to 14.6 lb NO_x/ton, NO_x emissions were reduced to 8.4 to 10.7 lb NO_x/ton, respectively, corresponding to 27 to 36 percent reduction. Variation of the ammonia injection rate, within the range tested, had no major effect on NO_x emissions, as measured in lb NO_x/ton glass. However, ammonia slip increased monotonically with increasing injection rate, as expected, and NO_x *concentration* (ppm) generally decreased with ammonia injection rate.

5.5 SUMMARY

Table 5-9 summarizes the reported controlled NO_x emission levels for each of the technologies discussed in Chapter 5. NO_x emissions are reported in units of both lb NO_x/ton glass and lb NO_x/MM Btu. These are related by the heat input, in MM Btu/ton glass, which is roughly heat input of 6 MM Btu/ton (from Chapter 3), but varies with the

TABLE 5-8. CURRENT SNCR INSTALLATIONS ON GLASS-MELTING FURNACES

Client	Location	Number of units	Fuel	Heat release MM Btu/hr	Startup date	Licensed DeNO _x (%)	NO _x emissions (lb/ton)		
							Uncontrolled	Controlled	NO _x reduction (%)
PPG Industries	Fresno, CA	1	Gas	150	1981	60 ^a	23.6 ^b	10.5 ^b	56
LOF Glass	Lathrop, CA	1	Gas/lpg	175	1987	51 ^c 31 ^e	11.5 ^d	—	—
AFG Industries	Los Angeles, CA	1	Gas	125	1987	61	13.9 ^f	9.7 ^f	30
SHOTT	Germany	1	Gas	9	9	9	—	—	—
BULACH ^g	Switzerland	1	Gas	67	1992	>50%	—	—	—

^a PPG has since modified this system to a proprietary design that also uses ammonia injection.¹¹⁷ It is not, strictly speaking, an Exxon Thermal DeNO_x system.

^b Average of 1990 and 1991 tests reported in Section 114 responses.

^c Reference 119.

^d Average of 1986 and 1987 tests reported in Section 114 responses.

^e Reference 130.

^f Average of two tests in 1988 reported in Section 114 responses.

^g Not engineered by Exxon Research & Engineering Company.

TABLE 5-9. SUMMARY OF NO_x EMISSION REDUCTIONS FOR VARIOUS TECHNOLOGIES

Technology	NO _x emissions								Reductions from uncontrolled levels (%) ^a		References(s)
	Uncontrolled				Controlled						
	lb NO _x /ton	lb NO _x /MM Btu	lb NO _x /ton	lb NO _x /MM Btu	lb NO _x /ton	lb NO _x /MM Btu	lb NO _x /ton	lb NO _x /MM Btu	NO _x /ton	lb NO _x /MM Btu	
Combustion Modifications											
Modified burners											
Sorg	4.1	0.68 ^b	2.4	0.41 ^b	41	41					32
Körting	18.2	3.0 ^b	6.1 ^c	1.0 ^b	66	66					34, 36
Oxy-firing	21.6	4.3	2.1	0.50	90	88					54
	5.0	1.3	0.81	0.24 ^d	84	82					38
Process Modifications											
Modified furnace	NR ^e	NR ^e	1.4 ^f	0.23 ^{b,f}	— ^e	— ^e					69
Cullet/batch preheat											
Tecogen	5.4	0.90 ^b	3.3	0.41	39	39					83
Zippe	NR	NR	NR	NR	12 ^g	12 ^g					89
Nienburger ^h	NR	NR	NR	NR	20	20					91
Electric boost ^h	6.5	i	6.4 ^j	i	2	2					94
	6.5	i	3.4 ^j	i	48	48					94
Postcombustion Modifications											
SCR											
	10.1	1.7 ^b	2.1 ^k	0.35 ^{b,k}	79	79					110
	NR	NR	NR	NR	70 ^l	70 ^l					111
SNCR											
	23.6	3.9 ^b	11.7 ^m	2.0 ^b	50	50					135
	22.3 ⁿ	3.7 ^b	9.2 ⁿ	1.5 ^b	59	59					135
	14.6 ⁿ	2.4 ^b	10.7 ⁿ	1.8 ^b	27	27					136
	13.1 ⁿ	2.2 ^b	8.4 ⁿ	1.4 ^b	36	36					136
	14.0 ^o	2.3 ^b	9.7	1.6 ^b	31	31					131
	17.9 ^a	3.0 ^b	12.4	2.1 ^b	31	31					131

See footnotes on following pages.

TABLE 5-9. (continued)

NR = Not reported.

- a Reductions from uncontrolled NO_x emission levels are calculated from values reported in the columns labeled "uncontrolled" and "controlled." Emissions are reported in units of both lb NO_x/ton glass and lb NO_x/MM Btu. These two values are related by the heat input required to melt the glass, in MM Btu/ton glass.
- b Calculated assuming 6 MM Btu/ton glass (also see Chapter 3).⁵⁸ Slavejkov et al. use a value of 4.5 MM Btu/ton.¹³²
- c References on this technology give only NO_x concentrations, not the corresponding flue gas flow that is needed to calculate lb NO_x/ton glass. Assuming (1) the fuel to be pure methane, (2) 10 percent excess air, (3) 21 x 10³ Btu/lb methane, it can be calculated from stoichiometry that the flue gas flow rate is about 68 scfm per ton/day of glass produced. This agrees with a value of 65 scfm/ton/day that can be calculated from de Saro and Doyle,⁸⁵ but could vary widely for other furnaces. Using this value, the controlled emissions can be calculated from NO_x concentrations of 600 to 750 ppm given by Barklage-Hilgefort and Sieger.³⁶ The value shown here is for 750 ppm NO_x (as NO).
- d This furnace has electric boost corresponding to about 14 percent of the total energy input and this is *not* accounted for in calculating these values of NO_x emissions.
- e This is a new installation that includes the furnace as well as heat recovery and other features designed to improve productivity and minimize NO_x. Because it is not an add-on control, there is no direct comparison to an "uncontrolled" emission level. Based on an uncontrolled level for container glass furnaces of 10 lb/ton (Table 4-2, Chapter 4), the controlled emissions would correspond to an 86 percent reduction.
- f Cullet takes about half the energy, in Btu/ton, to melt and therefore the higher the cullet content, the lower the NO_x emissions. Thus, this low value, which was measured at 80 percent cullet, would be higher with less cullet.
- g No data other than calculations showing a 12 percent decrease in energy input is given. This would correspond to a 12 percent reduction in NO_x.
- h Data for the Nienburger preheater is not available. See Reference 91.
- i NO_x reductions from electric boost are directly proportional to the percent of energy input, i.e., if 10 percent of the fuel to the furnace is replaced by electricity this would correspond to a 10 percent reduction in NO_x, all else being equal. Electric boost is used only in the container glass industry, typical boosts are 5 to 15 percent of the energy to the furnace.
- j Two levels of electric boost were used by Ryder.⁹⁴ Emissions with no boost were 6.5 lb/ton (at a pull of 220 ton/day) and decreased to 6.4 lb/ton (at a pull of 280 ton/day) with 700 kW boost. At 950 kW boost, pull increased to 280 ton/day, and NO_x emissions decreased to 3.4 lb NO_x/ton.
- k Calculated from a flue gas flow rate of 29,500 scfm and an outlet NO_x level ("as NO₂") of 195 ppm, as reported in Reference 133.
- l Only the percent NO_x reduction is given, not the *actual* uncontrolled or controlled levels.

TABLE 5-9. (continued)

- m The uncontrolled emissions for two tests at the PPG (Fresno, CA) plant are 23.6 and 22.3 lb NO_x/ton glass and the corresponding controlled emissions are 11.7 and 9.2 lb NO_x/ton. Destefano also reports an NO_x reduction of 47 percent (1,175 to 550 ppm) for this plant, but does not give the corresponding glass production rate needed to calculate lb NO_x/ton glass.¹²³
- n Uncontrolled emissions are reported as 13.1 to 14.6 lb NO_x/ton glass. The *actual* NO_x emission reduction was tested at various ammonia injection rates. Two direct comparisons of NO_x emissions without ammonia (uncontrolled) and with ammonia are given in Reference 136. In one case, the reduction is from 13.1 to 8.42 lb/ton (35.7 percent) and in the other from 14.6 to 10.7 lb/ton (26.7 percent).
- o Reference 131 reports only the controlled level of emissions from tests in 1991 and 1992 and the corresponding *percent* NO_x reduction. The value shown here for uncontrolled emissions is *calculated* from these two values.

thermal efficiency of the furnace and would be lower for high proportions of cullet. It is important to look at both measures of NO_x emissions—lb/ton glass and lb/MM Btu. Furnace energy input (MM Btu/ton glass) as well as NO_x emissions generally increase with furnace age because the furnace refractory insulation gradually deteriorates. Except for oxy-firing, the two measures of NO_x controlled emissions in Table 5-9 are directly proportional assuming 6 MM Btu/ton glass is accurate. For oxy-firing, however, much less energy is needed because nitrogen is not present in the combustion air and energy is not used (and then lost up the stack) to heat it in the furnace. For oxy-firing, a value of 3.4 MM Btu/ton is reported,¹³⁷ though this varies with different furnaces (which have different levels of air infiltration) and oxygen sources (which contain different amounts of nitrogen).

Combustion modifications in Table 5-9 include modified burners and oxy-firing. A NO_x reduction of 66 percent is reported for one low NO_x burner. This is the only test data available, though the NO_x reduction is somewhat higher than that reported in other applications.⁵ Oxy-firing results in NO_x reductions of 84 to 90 percent (measured in lb NO_x/ton glass) and 82 to 88 percent (measured as lb NO_x/MM Btu). These data are from large-scale container glass melting furnaces.

Process modifications include a modified furnace, cullet/batch preheat, and electric boost. The modified furnace achieves low levels of NO_x, but it is not an add-on control. Rather, it incorporates a number of heat recovery and design features to achieve NO_x reduction and higher productivity. Insufficient data are available to evaluate cullet/batch preheat as an NO_x control technique. The widely varying values in Table 5-9 are due to widely varying cullet/batch ratios, proportion of the cullet that is preheated, proportion of the flue gas used in the preheater, and other variables. In the references cited, there is insufficient information to compare directly each of the three processes.

Electric boost simply substitutes one form of energy for another. A general assumption is that NO_x emissions from the *furnace* are lowered in direct proportion to the proportion of the furnace energy that is input as electricity. A thermal input of 6 MM Btu/ton corresponds roughly to an electrical input of 880 kWh/ton. This value is for a batch containing 10 percent cullet¹³⁸; of course, the higher the cullet content, the lower the melting energy needed. [880 kWh = 3 MM Btu, meaning that electrical melting (or boosting) is about twice as energy efficient as thermal melting.] Dividing these two values, 147 kWh of electrical energy replaces 1 MM Btu of thermal input. One MM Btu of

thermal input would, in turn, correspond to one-sixth or 17 percent, of the thermal input into the furnace, corresponding to a NO_x reduction of 17 percent, all else being equal.

Postcombustion modifications in Table 5-9 include SCR and SNCR. SCR reduces NO_x emissions in glass furnaces by 70 to 79 percent, SNCR by 27 to 50 percent.

Based on the information in Table 5-9, NO_x percent reductions are shown in Table 5-10 for each generic technology. NO_x reductions based on these uncontrolled levels are used in calculating cost effectiveness in Chapter 6. Table 5-11 summarizes the current status of the technologies shown in Tables 5-9 and 5-10. For flat glass, only SNCR and electric boost have been demonstrated, though electric boost is no longer used.⁹⁵ Oxy-firing may be applicable for flat glass, but is not yet demonstrated. For container glass, only SNCR is not demonstrated, though it may be feasible. Cullet preheat has been demonstrated, but now is not used. For pressed/blown glass furnaces, modified burners, oxy-firing, and electric boost are the only technologies that have been demonstrated.

**TABLE 5.10. CONTROLLED NO_x PERCENT REDUCTION
USED FOR CALCULATING COST EFFECTIVENESS**

Technology	NO _x Reduction (%)
Combustion modifications	40
Modified	
Oxy-firing	85
Process modifications	
Modified furnace	75 ^b
Cullet preheat	25
Electric boost	10
Postcombustion modifications	
SCR	75
SNCR	40

^a See Table 5-9 for a summary of reported NO_x reductions reported for these technologies.

^b Based on uncontrolled emissions of 6.0 lb NO_x/ton [calculated assuming 10 lb/ton for the 20 percent of the batch that is virgin^{44,65,139} and 5 lb/ton for 80 percent of the batch that is cullet: (10 x 0.2) + (5 x 0.8) = 6 lb/ton] and controlled emissions of 1.4 lb/ton as reported in Reference 69. The resulting value of 77 percent NO_x reduction is rounded to 75 percent.

TABLE 5.11. STATUS OF NO_x CONTROL TECHNOLOGIES FOR VARIOUS GLASS FURNACES

NO _x Control Technology	Furnace Type		
	Flat	Container	Pressed/blown
Combustion modifications			
Modified burners	not demonstrated	demonstrated ¹³²	demonstrated ¹⁴⁰
Oxy-firing	not demonstrated, but possibly feasible ³⁹	demonstrated ^{38,54,62}	demonstrated
Process modifications			
Modified furnace	not demonstrated	demonstrated ⁶⁹⁻⁷¹	not demonstrated
Cullet preheat	not demonstrated	demonstrated, but not now used ^{76,77,83}	not demonstrated
Electric boost	demonstrated, but not now used ⁹⁵	demonstrated ^{93,96}	demonstrated
Postcombustion modifications			
SCR	not demonstrated	demonstrated ^{110,111}	not demonstrated
SNCR	demonstrated ^{131,135,136}	not demonstrated, but possibly feasible	not demonstrated

5.6 REFERENCES

1. Moilanen, G.L., and B. Van Kalsbeek. NO_x Control Options for Glass Furnaces. *Ceram. Eng. Sci. Proc.* 12(3-4):632-649. 1991.
2. Kokkinos, A., J.E. Cichanowicz, R.E. Hall, and C.B. Sedman. Stationary Combustion NO_x Control: A Summary of the 1991 Symposium. *J. Air Waste Manage. Assoc.* 1252. 1991.
3. Ref. 1, p. 640.
4. Cooper, D.C. *Air Pollution Control: A Design Approach.* PWS Engineering. 1986.
5. Sommerlad, R.E. Overview of NO_x Control Technologies. NO_x Control V Seminar. Long Beach, CA. Council of Industrial Boiler Owners. Burke, VA. February 10-11, 1992. Pp. 19-29.
6. Joseph, G.T., and D.S. Beachler. *Student Manual, APTI Course 415, Control of Gaseous Emissions.* U.S. Environmental Protection Agency, Air Pollution Training Institute. EPA 450/2-81-006. December 1981. p. 7-12.
7. Siddiqi, A.A., and J.W. Tenini. NO_x Controls in Review. *Hydrocarbon Processing.* 115-124. October 1981.
8. Campbell, L.M., D.K. Stone, and G.S. Shareef. *Sourcebook: NO_x Control Technology Data.* U.S. Environmental Protection Agency, Air and Energy Engineering Research Laboratory. Contract No. 68-02-4286, EPA-600/2-91-029. July 1991.
9. Clarke, M.J. Minimizing NO_x. *Waste Age.* pp. 132-138. November 1989.
10. McInnes, R., and M.B. von Wormer. Cleaning Up NO_x Emissions. *Chem. Eng.* p. 131. September 1990.
11. Pont, R.S. Pollution Control by Burner Design and Operation. *Glass Tech.* 32(3):58. 1991.
12. Burd, V. Squeezing Clean Energy. *Chem. Eng.* pp. 145-159. March 1992.
13. Ref. 4, p. 465.
14. Ref. 6, p. 7-7.
15. Abbasi, H.A., and D.K. Fleming. Combustion Modifications for Control of NO_x Emissions from Glass Melting Furnaces. *Ceram. Eng. Sci. Proc.* 9(3-4):168-177. 1988.
16. Neff, G.C. Reduction of NO_x Emissions by Burner Application and Operational Techniques. *Glass Tech.* 31(2):37-41. April 1990.

17. Abbasi, H.A., and D.K. Fleming. Development of NO_x Control Methods for Glass Melting Furnaces. Gas Research Institute. Final Report No. GRI-87/0202. August 1987.
18. Ref. 17, p. 47.
19. Letter and attachments from Fries, R.R., Glass Packaging Institute, Washington, DC, to Neuffer, W.J., EPA/OAQPS, Research Triangle Park, NC. April 8, 1993. Comments on draft ACT.
20. Ref. 15, p. 171.
21. Ref. 11, p. 61.
22. Ref. 17, p. 57.
23. Ref. 17, p. 71.
24. Ref. 17, p. 55.
25. Neff, G.C., M.L. Joshi, and M.E. Tester. Development of a Low NO_x Method of Gas Firing. Ceram. Eng. Sci. Proc. 12(3-4):650-660. 1991.
26. Ref. 4, pp. 466-467.
27. Ref. 8, pp. 25-29.
28. Ref. 7, p. 117.
29. Ref. 4, p. 467.
30. Ref. 1, p. 642.
31. Letter and attachments from Newell, P., Guardian Industries, Kingsburg, CA to Neuffer, W.J., EPA/OAQPS, Research Triangle Park, NC. August 16, 1993. Information on oil firing and low NO_x burners.
32. Letter and attachments from Aker, J.E., Teichmann Sorg Group, Ltd., Pittsburgh, PA, to Neuffer, W.J., EPA/OAQPS, Research Triangle Park, NC. April 16, 1993. Comments on draft ACT.
33. Letter from Moore, R.H., Teichmann, Sorg, Inc., McMurray, PA, to Spivey, J.J., Research Triangle Institute, Research Triangle Park, NC. Comments on June 11, 1993 meeting minutes.
34. Sieger, W. Development of Reduced NO_x Burners. Glass Tech. 31(1):6. 1990.
35. Glass. Reduced NO_x with Air Staging System. p. 217. ISSN 0017-0984. June 1991.

36. Barklage-Hilgefert, H., and W. Sieger. Primary Measures for the NO_x Reduction on Glass Melting Furnaces. *Glastech.* 62(5):151. 1989.
37. Scully, P.F. Green Glass Now? *Glass International.* June 1990.
38. Moore, R.D., and J.T. Brown. Conversion of a Large Container Furnace from Regenerative Firing to Direct Oxy Fuel Combustion. 1991 Glass Problems Conference. American Ceramic Society. Westerville, OH. 1992.
39. Summary of telephone conversation, J. Brown, Corning, Inc., Corning, NY, to J.J. Spivey, Research Triangle Institute, Research Triangle Park, NC, July 22 and August 17, 1993. Feasibility of oxy-firing for glass furnaces.
40. Tuson, G.B., H. Kobayashi, and E.J. Lauwers, Industrial Experience with Oxy-Fuel Fired Glass Melters, presented at Glassman Europe 93, Lyon, France, April 28, 1993, ©Praxair Inc., Tarrytown, NY.
41. Slavejkov, A.G., P.B. Eleazar, L.G. Mayotte, and M.L. Joshi. Advanced Oxy-Fuel Burner System for Glass Melting: A Performance Report. Presented at the 90th Annual Meeting and Convention. Canadian Ceramic Society. Toronto, Canada. February 16-18, 1992.
42. Baukal, C.E., P.B. Eleazar, and L.K. Farmer. Basis for Enhancing Combustion by Oxygen Enrichment. *Ind. Heating.* p. 23. February 1992.
43. Baukal, C.E., and A.I. Dalton. NO_x Reduction with Oxygen-Fuel Combustion. In: 1990 Am. Flame Res. Conf. Symposium. October 1990. p. 4.
44. Ref. 16, p. 39.
45. Ref. 35, p. 217.
46. Ref. 43, pp. 1-10.
47. Ref. 42, p. 22.
48. Gupta, P. J. Non-Crystalline Solids. 38(39):761-766. 1980.
49. Joshi, S.V. Oxygen Enriched Air/Natural Gas Burner System Development. Gas Research Institute. Chicago, IL. 1985.
50. Kobayashi, H., G.B. Tuson, and E.J. Lauwers, NO_x Emissions from Oxy-Fuel Fired Glass Melting Furnaces. Paper presented at the European Society of Glass Sciences and Technology Conference on Fundamentals of the Glass Manufacturing Process. Sheffield, England. September 9-11, 1991. Union Carbide. Tarrytown, NY. p. 4.
51. Ref. 50, p. 3.
52. Ref. 50, p. 12.

53. Ref. 50, p. 8.
54. Kobayashi, H., G.B. Tuson, and E.J. Lauwers, NO_x Emissions from Oxy-Fuel Fired Glass Melting Furnaces. Paper presented at the European Society of Glass Sciences and Technology Conference on Fundamentals of the Glass Manufacturing Process. Sheffield, England. September 9-11, 1991. Union Carbide. Tarrytown, NY.
55. Westbrook, C.K. Computation of Adiabatic Flame Temperatures and Other Thermodynamic Quantities. Proc. Ind. Comb. Tech. Symp. M.A. Lukasiewicz (ed.). Chicago, IL. 1986. Pp. 143-150.
56. Kobayashi, H. Oxygen Enriched Combustion System Performance Study. Prepared for U.S. Department of Energy. Idaho Operations Office. Report DOE/ID/12597. March 1987.
57. Baukal, C.E., and A.I. Dalton. Nitric Oxide Measurements in Oxygen-Enriched Air-Natural Gas Combustion Systems. In: Proc. Fossil Fuel Combustion Symp. Petroleum Div. of ASME, Warrendale, PA. New Orleans, PD - Vol. 30, January 1990. Pp. 75-79.
58. Ryder, R.J. Use of Electric Boost to Reduce Glass Furnace Emissions. Am. Ceram. Soc. Bull. 57(11):1025. November 1978.
59. Ref. 50, p. 9 and Figure 6.
60. American Ceramic Society Bulletin, April 1990. Cleanfire™ LoNO_x Burner. Air Products Bulletin 337-9104. Allentown, PA. 1991.
61. Air Products. Air Products and Combustion Tec, Providing Environmental Solutions for the Glass Industry. Air Products Bulletin 336-9102. Allentown, PA. 1991.
62. Ref. 54, pp. 11-12.
63. Brown, J.T. Development—History and Benefits of Oxygen-Fuel Combustion for Glass Furnaces. Corning Glass. Corning, NY. Presented at Latin American Technical Symposium on Glass Manufacture. Sao Paulo, Brazil. November 18, 1991.
64. Brown, J.T. 100% Oxygen Fuel Combustion for Glass Furnaces. Ceram. Eng. Sci. Proc. 12(3-4):594-609. 1991.
65. Shelley, S. Chem. Eng. p. 67. December 1992.
66. Ref. 38, p. 5-6.
67. Ref. 64, p. 598.
68. Ref. 1, pp. 636-637.

69. Moore, R.H. LoNO_x[™] Glass Melting Furnace. *Ceram. Eng. Sci. Proc.* 11(1-2):89-101. 1990.
70. Moore, R.H. LoNO_x Melter Shows Promise. *Glass Indust.* p. 14. March 1990.
71. American Glass Review. Satisfied Customer Orders Second LoNO_x[™] Melter. pp. 8-9. October 1991.
72. Ref. 69, p. 100.
73. Ref. 69, p. 90.
74. Ref. 69, p. 94.
75. Ref. 69, p. 101.
76. Cole W.E., F. Becker, L. Donaldson, S. Panahe. Operation of a Cullet Preheating System. *Ceram. Eng. Sci. Proc.* 11(1-2):59. 1990.
77. De Saro, R., L.W. Donaldson, and C.W. Hibscher. Fluidized Bed Glass Batch Preheater, Part II. *Ceram. Eng. Sci. Proc.* 8(3-4):175. 1987.
78. Ref. 76, p. 57.
79. Ref. 76, pp. 53-68.
80. Ref. 76, pp. 57-58.
81. Ref. 76, p. 60.
82. Ref. 77, pp. 171-180.
83. De Saro, R., and E. Doyle. Glass Batch Preheater Program. Gas Research Institute. Chicago, IL. Final Report No. GRI-87/0366. September 1987.
84. Ref. 83, p. 100.
85. Ref. 83, pp. 87, 108.
86. Ref. 83, p. 108.
87. Ref. 83, p. 130.
88. Ref. 83, pp. 116-117.
89. Zippe, B.H. Reliable Cullet Preheater for Glass Furnaces. *Ceram. Eng. Sci. Proc.* 12(3-4):550-555. 1991.

90. Letter from Zippe Industrieanlagen GmbH, Wertheim, Germany, to U.S. Environmental Protection Agency/OAQPS, Research Triangle Park, NC. April 5, 1993.
91. Enniga, G., K. Dytrich, H. Barklage-Hilgefert, "Practical Experience with Raw Materials Preheating on Glass Melting Furnaces," unpublished paper from Neinburger Glas GmbH, Nienburger, Germany, undated.
92. Ref. 91, p. 9.
93. Ref. 1, p. 638.
94. Ref. 58, pp. 1024-1031.
95. Letter from Horbatch, W., Ford Motor, Dearborn, MI, to Neuffer, W.J., EPA/OAQPS, Research Triangle Park, NC. July 27, 1993. Ford experience with electric boost on float glass furnaces.
96. Rindone, G.E., J.R. Hellmann, and R.E. Tressler. An Assessment of Opportunities for Gas-Fired Boosting of Glassmelting Processes. Gas Research Institute. Chicago, IL. Topical Report No. GRI-89/0254. January 1990. p. 1.
97. Ref. 96, p. 7.
98. Ref. 58, p. 1024.
99. Ref. 58, pp. 1027-1028.
100. Ref. 17, p. 39.
101. Moore, R.D., and R.E. Davis. Electric Furnace Application for Container Glass. Ceram. Eng. Sci. Proc. 8(3-4):188-199. 1987.
102. Rindone, G.E., J.R. Hellmann, and R.E. Tressler. An Assessment of Opportunities for Gas-Fired Boosting of Glassmelting Processes. Gas Research Institute. Chicago, IL. Topical Report No. GRI-89/0254. January 1990.
103. Ref. 101, p. 192.
104. Ref. 101, p. 191.
105. Letter and attachments from Wax, M.J., Institute of Clean Air Companies, Washington, DC, to Neuffer, W.J., EPA/OAQPS, Research Triangle Park, NC. May 14, 1992. Response to Section 114 letter on glass manufacturing.
106. Ref. 7, p. 119.

107. Joseph, G.T., and D.S. Beachler. Student Manual, APTI Course 415 Control of Gaseous Emissions. U.S. Environmental Protection Agency, Air Pollution Training Institute. EPA 450/2-81-006. December 1981.
108. Krause, W. Glass Melting Strategies at Oberland Glas. Glass Intl. pp. 51-52. June 1990.
109. Letter and attachments from Wax, M.J., Institute of Clean Air Companies, Washington, DC, to Neuffer, W.J., EPA/OAQPS, Research Triangle Park, NC. April 8, 1993. Comments on draft ACT.
110. Grove, M., and W. Strum. NO_x Abatement System: Using Molecular Sieve Catalyst Modules for a Glass Melting Furnace. Ceram. Eng. Sci. Proc. 10(3-4):325-337. 1989.
111. Chem. Eng. A DeNO_x System That Handles Hot and Dusty Waste Streams. p. 21. October 1992.
112. U.S. Patent 3,900,554. August 19, 1975.
113. Ref. 1, p. 643.
114. Ref. 107, p. 7-13.
115. Ref. 7, p. 120.
116. Ref. 8, p. 38.
117. Hughes, David E. Meeting Glass with Reduced NO_x Emissions. U.S. Patent 4,328,020. May 1982.
118. Ref. 1, p. 644.
119. Haas, G.A. Selective Noncatalytic Reduction (SNCR): Experience with the Exxon Thermal DeNO_x Process. Presented at the NO_x Control V Conference. Council of Industrial Boiler Owners. Long Beach, CA. February 10-11, 1992.
120. Letter and attachments from Haas, G.A., Exxon, Florham Park, NJ to Neuffer, W.J., EPA/OAQPS, Research Triangle Park, NC, April 8, 1993. Comments on draft ACT.
121. Ref. 8, p. 40.
122. Ref. 10, p. 154.

123. Mincy, J.E. SNCR Technology: The Next Generation. Presented at NO_x V Conference. Long Beach, CA. Council of Industrial Boilers. Burke, VA. February 10-11, 1992. p. 2.
124. Letter and attachments from Pickens, R., Nalco Fuel Tech., Naperville, IL, to Neuffer, W.J., EPA/OAQPS, Research Triangle Park, NC. March 26, 1993. Comments on draft ACT.
125. Ref. 123, p. 3.
126. Coal and Synfuels Technology. Pasha Publications. Arlington, VA. February 24, 1992. p. 7.
127. Hofman, J.E., et al. NO_x Control in a Brown Coal-Fired Utility Boiler. In: Proc. 1989 Joint Symposium on Stationary Combustion NO_x Control. San Francisco, CA. March 6-9, 1989. v. 2. EPA-600/9-89-062b (NTIS P889-220537). June 4, 1989.
128. Ref. 10, p. 134.
129. Ref. 2, p. 1255.
130. Letter and attachments from Benney, J.C., Primary Glass Manufacturers Council, Topeka, KS to Neuffer, W.J., EPA/OAQPS, Research Triangle Park, NC. April 22, 1993. Comments on draft ACT.
131. Letter and attachments from Keil, J.R., Libbey Owens Ford, Toledo, OH, to Neuffer, W.J., EPA/OAQPS, Research Triangle Park, NC. June 29, 1993. Response to Section 114 letter on glass manufacturing.
132. Slavejkov, A.G., C.E. Baukal, M.L. Joshi, and J.K. Nabors. Advanced Oxygen-Natural Gas Burner for Glass Melting. 1992 Int. Gas Res. Conf., Orlando, FL. Gas Research Institute. Chicago, IL. November 16-19, 1992. p. 319.
133. Ref. 110, p. 330.
134. DeStefano, J.T. Postcombustion NO_x Control Technology for Glass Furnaces, Update. Presented at 45th Glass Problems Conference. Columbus, Ohio. American Ceramic Society. November 1984. p. 243.
135. Letter and attachments from Osheka, J.W., PPG Industries, Inc., Pittsburgh, PA, to Jordan, B.C., EPA/OAQPS, Research Triangle Park, NC. September 1, 1992. Response to Section 114 letter on glass manufacturing.
136. Letter and attachments from Robinson, J.R., AFG Industries, Inc. Kingsport, TN, to Jordan, B.C., EPA/OAQPS, Research Triangle Park, NC. August 20, 1992. Response to Section 114 letter on glass manufacturing.
137. Ref. 38, p. 4.

138. Ref. 101, p. 189.
139. Ref. 15, p. 168.
140. Summary of June 11, 1993 meeting, Moore, R.H., Teichmann Sorg, McMurray, PA, Neuffer, W.J., EPA/OAQPS, Research Triangle Park, NC, Spivey, J.J., Research Triangle Institute, Research Triangle Park, NC.

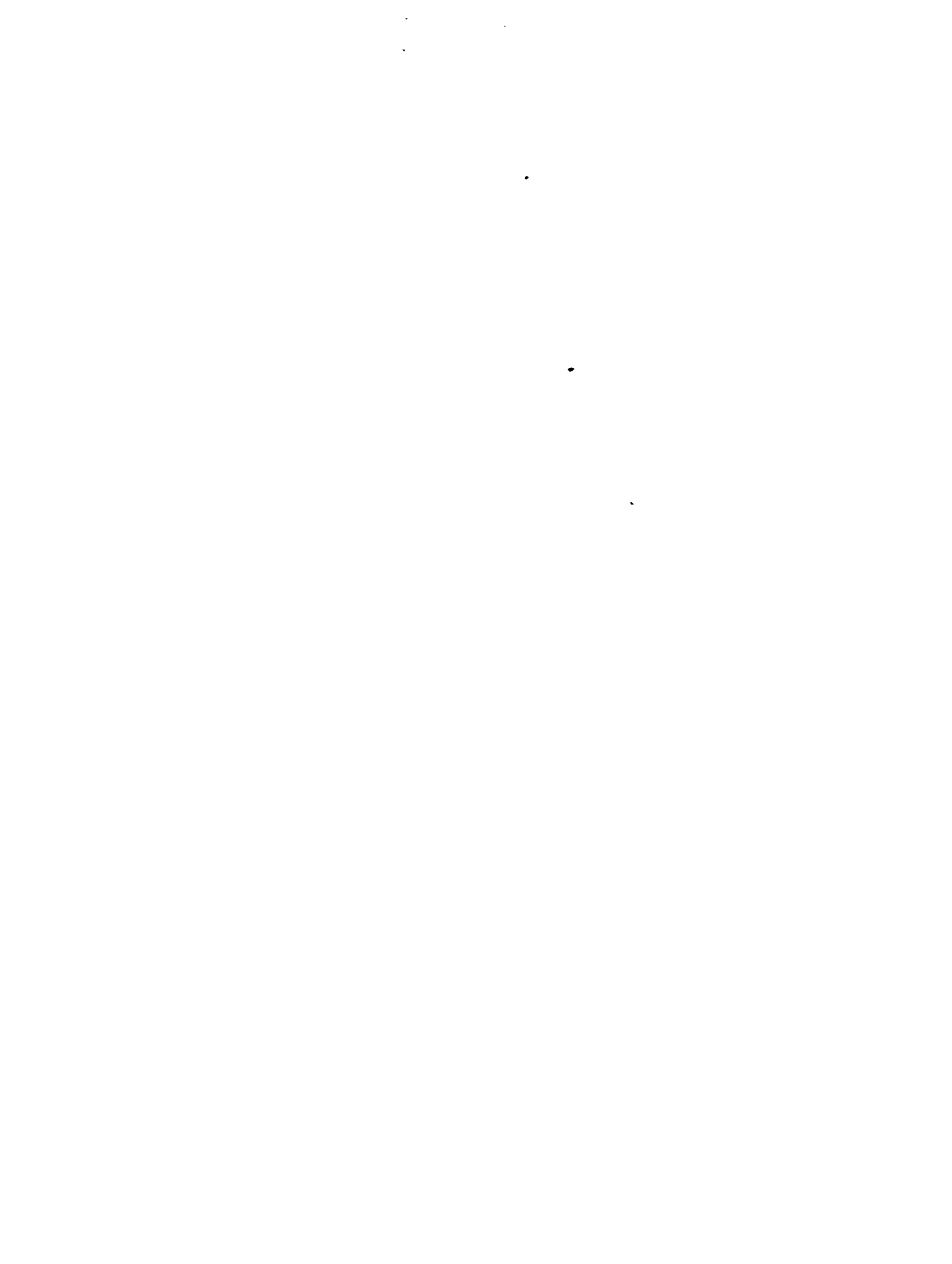

CHAPTER 6 COSTS OF NO_x CONTROLS

6.1 INTRODUCTION

Capital and annual costs as well as cost effectiveness (\$/ton NO_x removed) are presented for the following NO_x control technologies described in Chapter 5:

Combustion modifications

- low NO_x burners
- oxy-firing

Process modifications

- cullet preheat
- electric boost

Postcombustion modifications

- selective catalytic reduction (SCR)
- selective noncatalytic reduction (SNCR)

Costs were not available from the vendor or from any installation of the modified furnace.

Thus, costs and cost effectiveness for this control technique are not presented.

The percent NO_x reductions for each technology used in making the cost effectiveness calculations are shown in Table 6-1. The corresponding annual NO_x reductions (tons NO_x removed/yr) are given for each individual technology in subsequent sections.

Costs are developed for the three model plants (50, 250, and 750 tons glass/day) shown in Table 6-2. These correspond, roughly, to plants in the pressed/blown, container, and flat glass segments of the glass industry, respectively.

The capital and operating costs were developed using information available in the literature and from Section 114 requests. In many cases, site-specific details were not

**TABLE 6-1. CONTROLLED NO_x EMISSION LEVELS
USED FOR CALCULATING COST EFFECTIVENESS**

Technology	Controlled NO _x Emissions (lb NO _x / ton glass)		
	Pressed/Blown	Container	Flat
Combustion modifications			
Low NO _x burners	13.2	6.0	9.5
Oxy-firing	3.3	1.5	2.4
Process modifications			
Cullet preheat	16.5	7.5	NF
Electric Boost	19.8	9.0	14.2
Postcombustion modifications			
SCR	5.5	2.5	3.9
SNCR	13.2	6.0	9.5

NF - Not feasible

TABLE 6-2. MODEL GLASS MELTING FURNACES

Plant size (tons/day)	Uncontrolled NO _x emissions		Flue gas flow rate (scfm) ^b	Flue gas NO _x concentration ^c	
	(lb NO _x /ton glass)	(lb NO _x /MM Btu) ^a		(ppm)	(mg/m ³)
50	22.0	3.67	3,400	2,700	3,610
250	10.0	1.67	17,000	1,220	1,640
750	15.8	2.63	51,000	1,930	2,590

^aBased on a heat requirement of 6 MM Btu/ton glass (from Chapter 4).

^bBased on 68 scfm per ton/day of glass. See Table 5-8, footnote b.

^cThis value is calculated from uncontrolled emissions in column 2 and a value of 68 scfm/ton/day of glass.

provided by the original references. Such details, including furnace age and outside air infiltration, can greatly affect both NO_x emissions and control costs.

Costs have been updated to January 1994 dollars using the equipment index component of the Chemical Engineering Plant Cost Index (January 1994 = 397.5). Capital costs are also scaled, as needed, using the following equation:

$$\frac{\text{Cost for size 1}}{\text{Cost for size 2}} = \left(\frac{Q_1}{Q_2} \right)^{0.6} \quad (6-1)$$

6.2 COMBUSTION MODIFICATIONS

6.2.1 Low NO_x Burners

Capital and annual costs were obtained for low NO_x burners from North American Manufacturing on a glass furnace producing 32 tons/day of glass.² This burner differs in design from the Körtig burner described in Section 5.2.2 in the way the staged air is introduced.³ This burner is substantially smaller than those used in larger glass furnaces. Nevertheless, in the absence of other cost information, these costs are scaled using Equation (6-1) and are shown in Table 6-3. Capital costs range from \$265,000 to \$1.34 million and annual costs from \$123,000 to \$621,000. For the purpose of cost calculations, a reduction of 40 percent was used. This percent reduction is consistent with low NO_x burner performance in other applications.⁵ Table 6-3 shows that the cost effectiveness ranges from \$ 790 to \$1,680 per ton of NO_x removed.

6.2.2 Oxy-Firing

Capital and operating costs for oxy-firing were available for a 250 tons/day regenerative furnace.⁶ Costs have been scaled to provide capital and operating costs for the other two plant sizes using Equation (6-1). In Table 6-4, Q₁ is 250 tons/day and Q₂ is either 50 or 750 tons/day. Table 6-4 shows that capital costs vary from \$1.93 to \$9.819 million. Cost effectiveness ranges from \$2,150 to \$5,300 per ton of NO_x reduced.

6.3 PROCESS MODIFICATIONS

6.3.1 Cullet Preheat

Costs were available for a Tecogen system on a 250 tons/day furnace.⁸ NO_x reduction and costs depend on the fraction of cullet in the batch. Costs are given in

TABLE 6-3. COSTS AND COST EFFECTIVENESS OF RETROFIT LOW NO_x BURNERS

Plant size (tons/day)	Capital cost (\$10 ³) ^a	Annualized cost (\$10 ³ /yr) ^b	NO _x reduction (ton NO _x /yr) ^c	Cost effectiveness (\$/ton NO _x removed)
50	265	123	73	1,680
250	695	320	167	1,920
750	1,340	621	790	790

^aThese costs are scaled using Equation (6-1) from costs provided by Gilbert for a 32-ton/day furnace.²

^bIt is assumed that there are no operating costs (also, no operating cost *savings* due to increased efficiency, if any, of this burner) and that all annual costs (maintenance and indirect costs) are 6 percent of the capital cost and that capital recovery is 40.2 percent, based on 10 percent for the 3-year ("2-4 year") burner life.² Annual costs are therefore calculated as 46.2 percent of the capital cost.

^cBased on 40 percent reduction, and 8,000 hr/yr operation, per Table 5-8.

TABLE 6-4. COSTS AND COST EFFECTIVENESS OF OXY-FIRING

Plant size (tons/day)	Capital cost (\$10 ³ /yr)	Annual cost (\$10 ³ /yr)	NO _x reduction (ton NO _x /yr) ^a	Cost effectiveness (\$/ton NO _x removed)
50	1,930 ^b	706 ^c	160	4,400
250	5,070	1,860	359	5,300
750	9,810 ^b	3,590 ^c	1,670	2,150

^aSee Table 5-8. 85 percent NO_x reduction is assumed.

^bThese values are scaled from the capital cost of \$5 x 103⁶ for a 150-ton/day furnace as follows: Capital cost = (Q₁/Q₂)^{0.6} where Q₁ and Q₂ are the plant sizes in tons/day.

^c These values are scaled from "operating costs" of \$22/ton for a 250-ton/day furnace as in footnote a, assuming 333 day/yr (8,000 hr/yr) operation. These "operating costs" account for all direct, indirect, and capital recovery costs.

Table 6-5 for 25 percent cullet, more or less representative of container and pressed/blown glass furnaces, respectively. Some container glass furnaces may operate on essentially 100 percent cullet, but this case is not considered here. Capital costs range from \$188,000 to \$492,000. Cost effectiveness range from \$ 890 to \$1,040 per ton of NO_x removed.

TABLE 6-5. COSTS AND COST EFFECTIVENESS FOR CULLET PREHEAT

Plant size (tons/day)	Capital cost (\$10 ³) ^a	Annual cost (\$10 ³ /yr) ^b	NO _x reduction (tons NO _x /yr)	Cost effectiveness (\$/ton NO _x removed)
50	188	42	46	890
250	492	110	104	1,040

^aCapital costs are available only for the Tecogen preheater. Costs given by Becker have been scaled using Equation (6-1) from 250 tons/day to the 50-tons/day model plant.⁸ Control costs are for preheaters using waste heat in the flue gas rather than separately fired preheaters.

^bAnnual costs are calculated based on a capital recovery of 10 percent/10 yr (16.275 percent of capital costs) plus 6 percent for maintenance and indirect operating costs, i.e., annualized costs are 22.3 percent of capital costs and are scaled using Equation (6-1) from those given for a 250-tons/day plant.⁸

6.3.2 Electric Boost

Electric boost costs are contained in Reference 10. Technical constraints limit electric boost to between 5 and 20 percent of the total energy input into the furnace. Electric boost is used only in the container glass industry. Costs and cost effectiveness are presented in Table 6-6 for 10 percent electric boost. Because NO_x reduction is directly proportional to the percent of furnace energy supplied electrically [as discussed in Section 5.3.2, i.e., 10 percent electric boost decreases NO_x emissions (lb NO_x/ton glass) by 10 percent], the cost *effectiveness* (\$/ton NO_x removed) is independent of the percent electric boost. Electric boost is not widely used in furnaces as small as 50 tons/day (possibly due to electrode placement and cost) nor furnaces as large as 750 ton/day (no furnaces of this size using electric boost are reported). As shown on Table 6-6, annual costs range from \$178,000 to \$525,000. Cost effectiveness range from \$2,600 to \$9,900/ton. Because NO_x removal is directly proportional to electric boost, the cost effectiveness for any of the three model plants is independent of the percent boost.

6.4 POSTCOMBUSTION MODIFICATIONS

6.4.1 Selective Catalytic Reduction

SCR costs depend primarily on the flue gas flow rate (scfm) and NO_x concentration. Assuming the SCR unit can be installed at a place in the process where the temperature is between about 350 and 500 °C (660 and 930 °F), no reheat is needed. The primary concern for SCR in glass furnaces is dust accumulation. The only cost available that explicitly accounts for installation of equipment to minimize dust prevention in a glass furnace is given as \$1.9 million for a unit to treat 29,400 scfm.¹³ [Assuming 68 scfm per ton/day of glass, per footnote b of Table 5-8, this would correspond to a 432-tons/day furnace.] The exact scope of this cost is not provided, but is assumed to include all capital costs. These capital costs range from \$528,000 (50 tons/day) to \$2.69 million (750 tons/day), although somewhat lower capital costs are also reported: from \$406,000 (50 tons/day) to \$1.38 million (750 tons/day).¹⁴ Annual costs are \$6/ton glass for a 500-tons/day SCR unit.¹⁵ Scaling this value using Equation (6-1), annual costs are shown in Table 6-7. These costs range from \$404,000 to \$1.2 million per year. Cost effectiveness ranges from \$800 to \$2,950 per ton of NO_x removed.

TABLE 6-6. COSTS AND COST EFFECTIVENESS OF ELECTRIC BOOST

Plant size (tons/day)	Annual cost (\$10 ³ /yr) ^a	NO_x reduction (ton NO_x /yr)	Cost effectiveness (\$/ton NO_x removed)
50	178	18	9,900
250	339	42	8,060
750	525	200	2,600

^aFor electric boost, separate capital costs are not available. The *incremental* cost of electric boost as \$40/ton glass compared to \$10/ton if gas is used.¹⁰ Approximate confirmation of this is stated that the *operating* cost for all electric melters is twice that of a regenerative natural gas melter.¹¹ This is assumed to be applicable only to furnaces in the range given by Reference 10, around 250 tons/day.¹² For the 50- and 750-tons/day cases above, this cost is scaled using Equation (6-1).

TABLE 6-7. COSTS AND COST EFFECTIVENESS FOR SCR

Plant size (tons/day)	Capital cost (\$10 ³) ^a	Annual cost (\$10 ³ /yr) ^c	NO _x reduction (ton NO _x /yr) ^b	Cost effectiveness (\$/ton NO _x removed)
50	530	400	140	2,950
250	1,390	770	310	2,460
750	2,690	1,200	1,490	810

^aCapital costs are scaled from a value of \$1.9 million given in Reference 13 for a unit treating 29,000 scfm. Using a value of 68 scfm/ton/day of glass (see Table 5-8, footnote b), this corresponds to a 432-ton/day furnace. This cost is scaled to the three furnaces shown above using Equation (6-1). ICAC provided capital costs of \$400,000, \$720,000, and \$1,360,000 for the three plant sizes above.¹⁴

^bNO_x reduction is taken as 75 percent, based on Table 5-8.

^cAnnual cost are calculated as \$6/ton glass for a 500-ton/day furnace.¹⁵ This is scaled using Equation (6-1) for the model plant sizes shown here.

6.4.2 Selective Noncatalytic Reduction

Capital and annual costs were available for two flat glass furnaces that use ammonia injected SNCR. The averages of these furnaces are 626 TPD, capital cost of \$ 1,400,000 and an annual cost of \$ 589,000.^{16,17} Capital and annual costs were obtained from Nalco for their urea based SNCR process for the three model sizes.¹⁸ These costs are much higher than costs for the ammonia-based SNCR. Costs are available for actual installations using SNCR ammonia and urea based in the ACT documents for utility boilers and Industrial/Commercial/Institutional Boilers. A cost comparison showed no major difference between the two systems. Thus, in this ACT document, no distinction is made between costs for the two different SNCR systems. The costs for the ammonia based SNCR system are assumed to be more accurate as they are based on actual installations. As shown in Table 5-10, a control efficiency of 40 percent was used. As shown in Table 6-8, capital costs ranged from \$ 310,000 to \$ 1,560,000. Cost effectiveness ranged from \$830 to \$2,000/ton. Cost and emission data were obtained from two flat glass installations.¹⁹ Cost effectiveness for these two installations are \$990 and \$1700/ton.

TABLE 6-8. COSTS AND COST EFFECTIVENESS FOR SNCR

Plant size (tons/day)	Capital cost (\$10 ³)	Annual cost (\$10 ³ /yr)	NO _x reduction (ton NO _x /yr)	Cost effectiveness (\$/ton NO _x removed)
50	310	130	70	1,770
250	810	340	170	2,000
750	1,560	660	790	830 (990 - 1700) ^a

^a Two actual installations at 40 and 30 percent control, respectively.

6.5 SUMMARY

Table 6-9 summarizes the cost effectiveness of the control technologies considered here. Cost effectiveness of low NO_x burners, cullet preheat and SNCR are similar. Cost effectiveness of oxy-firing is much higher but low NO_x emissions can be achieved. SCR achieves similar NO_x control levels as oxy-firing but cost effectiveness is much lower. Cost effectiveness for electric boost is also high.

TABLE 6-9. SUMMARY OF COST EFFECTIVENESS FOR NO_x CONTROL TECHNOLOGIES FOR GLASS FURNACES (\$/ton NO_x removed)

Plant size (tons/day)	Low NO _x burners	Oxy-firing	Cullet preheat	Electric boost	SCR	SNCR
50	1,680	4,400	890 ^a	9,900	2,950 ^a	1,770 ^a
250	1,920	5,300	1,040	8,060	2,460	2,000 ^a
750	790 ^a	2,150 ^a	N/F	2,600	800 ^a	830 (990 - 1700) ^b

N/F Not feasible

^a Not demonstrated

^b Two actual installations at 40 and 30 percent control, respectively.

6.6 REFERENCES

1. Abbasi, H.A., and D.K. Fleming. Combustion Modifications for Control of NO_x Emissions from Glass Melting Furnaces. *Ceram. Eng. Sci. Proc.* 9(3-4):168. 1988.
2. Letter and attachments from Gilbert, F.C., North American Manufacturing Company, Cleveland, OH, to Jordan, B.C., EPA/OAQPS, Research Triangle Park, NC. November 11, 1992. Response to Section 114 letter on glass manufacturing.
3. Barklage-Hilgefert, H., and W. Sieger. Primary Measures for the NO_x Control Methods for Glass Melting Furnaces. *Glastech.* 62(5):151. 1989.
4. Sieger, W. Development of Reduced NO_x Burners. *Glass Tech.* 31(1):6. 1990.
5. Sommerlad, R.E. Overview of NO_x Control Technologies. NO_x Control V Seminar. Long Beach, CA. Council of Industrial Boiler Owners. Burke, VA. February 10-11, 1992. Pp. 19-29.
6. Slavejkov, A.G., P.B. Eleazar, L.G. Mayotte, and M.L. Joshi. Advanced Oxy-Fuel Burner System for Glass Melting: A Performance Report. Presented at the 90th Annual Meeting and Convention. Canadian Ceramic Society. Toronto, Canada. February 16-18, 1992.
7. Ref. 6, p. 3.
8. Fax message from Becker, F., Tecogen, Inc., Waltham, MA, to Spivey, J.J., Research Triangle Institute, Research Triangle Park, NC. December 15, 1992. Cullet preheater costs.
9. Cole, W.E., F. Becker, L. Donaldson, and S. Panahe. Operation of a Cullet Preheating System. *Ceram. Eng. Sci. Proc.* 11(1-2):60. 1990.
10. Telecon. Newsome, M., Anchor Glass Company, Tampa, FL, to Spivey, J.J., Research Triangle Institute, Research Triangle Park, NC. November 10, 1992. Costs of electric boost.
11. Brown, J.T. 100% Oxygen Fuel Combustion for Glass Furnaces. *Ceram. Eng. Sci. Proc.* 12(3-4):608. 1991.
12. Letter and attachments from Newsome, M., Anchor Glass Company, Tampa, FL, to Jordan, B.C., EPA/OAQPS, Research Triangle Park, NC. October 2, 1992. Response to Section 114 letter on glass manufacturing.
13. Chem. Eng. A DeNO_x System That Handles Hot and Dusty Waste Streams. p. 21. October 1992.

14. Letter from Wax, M.J. Institute of Clean Air Companies, Washington, DC, to Spivey, J.J., Research Triangle Institute, Research Triangle Park, NC. January 7, 1993.
15. Grove, M., and W. Strum. NO_x Abatement System: Using Molecular Sieve Catalyst Modules for a Glass Melting Furnace. *Ceram. Eng. Sci. Proc.* 10(3-4):331. 1989.
16. Letter and attachments from Robinson, J.R., AFG Industries, Inc., Kingsport, TN, to Jordan, B.C., EPA/OAQPS, Research Triangle Park, NC. August 20, 1992.
17. Letter and attachments from Keil, J.R., Libbey Owens Ford, Toledo, Ohio, to Neuffer, W.J., EPA/OAQPS, Research Triangle Park, NC. June 29, 1993. Response to Section 114 letter on glass manufacturing.
18. Letter from Pickens, R.D., Nalco Fuel Tech, Naperville, IL, to Spivey, J.J., Research Triangle Institute, Research Triangle Park, NC. January 14, 1993.
19. Letter from Keil, John. Libbey-Owens-Ford, Toledo, OH, to Neuffer, W. J., U.S. EPA/OAQPS, Research Triangle Park, NC, June 30, 1994.

CHAPTER 7

ENVIRONMENTAL AND ENERGY IMPACTS OF NO_x CONTROLS

This chapter presents the energy and environmental impacts of the NO_x control technologies described in Chapter 5. These include low excess air, changing air/fuel contacting, retrofit low NO_x burners, oxy-firing, cullet preheat, electric boost, selective catalytic reduction (SCR), and selective noncatalytic reduction (SNCR).

7.1 AIR POLLUTION IMPACTS

7.1.1 NO_x Emission Reductions

Table 5-8 presents NO_x emission reductions for each of the technologies discussed above with the exception of low excess air (LEA) and changing air/fuel contacting. As discussed in Chapter 5, these two combustion modifications are assumed to be necessary to achieve the uncontrolled NO_x emissions levels of Table 6-1. Table 5-9 shows that NO_x reductions from 12 to 98 percent from uncontrolled levels can be achieved. The greatest reduction (98 percent) is achieved by oxy-firing.

7.1.2 Emissions Tradeoffs

7.1.2.1 Combustion Modifications. Combustion modifications (Section 5.2) include LEA, changing air/fuel contacting, low NO_x burners, and oxy-firing. These, like other combustion modifications designed to minimize NO_x may affect the emissions of CO and unburned hydrocarbons.

Low Excess Air. The formation of NO_x in a glass furnace depends on temperature, O₂/N₂ concentration, and residence time, per Equation (4-4) in Chapter 4. LEA operation will generally decrease NO_x emissions but may will increase CO emissions. Figure 7-1 shows this effect for an end-fired regenerative glass furnace producing about 165 tons of glass/day.¹ The lower the oxygen content of the flue gas (i.e., the lower the excess air), the lower the NO_x emissions. However, CO emissions increase rapidly below about 2.2

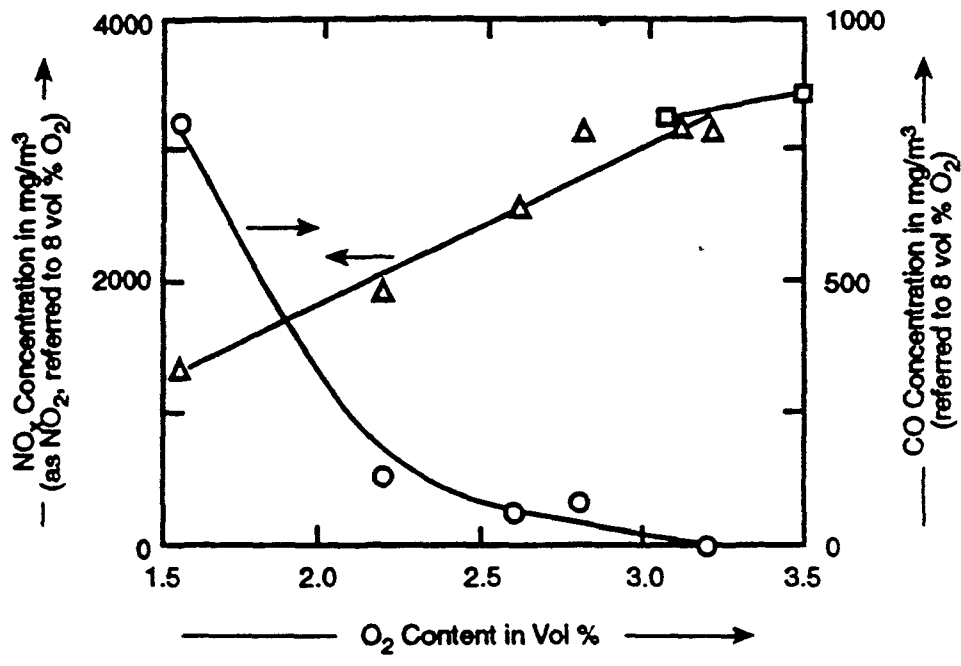

Figure 7-1. NO_x and CO concentrations of the flue gas as a function of the oxygen content from an end-fired regenerative furnace (1 mg NO/m³ = 0.75 ppm NO; 1 mg CO/m³ = 0.80 ppm CO).¹

percent oxygen. For this particular furnace, operation at about 2 percent oxygen in the flue gas (corresponding to about 13 percent excess air) minimizes both CO and NO_x emissions.

No adverse effect on glass quality is reported for NO_x up to 3100 ppm and CO concentrations above 1000 ppm.^{2,3} However, CO concentrations that result in a net reducing atmosphere in the furnace are known to adversely affect glass quality.⁴

Excess air levels in actual glass furnaces are highly site specific, though levels of 5 to 10 percent are typical of at least two commercial furnaces.³ Though not reported in this study, emissions of unburned hydrocarbons (HC) are generally directly proportional to CO emissions and thus would follow the same qualitative trend as CO emissions shown in Figure 7-1.

Changing Air/Fuel Contacting. As with LEA operation, any change in the combustion process that affects NO_x may affect CO and HC emissions. The effect of the mixing factor (a measure of air/fuel contacting defined Equation (5-1) in Section 5.2.1.2) on NO_x emissions is reported, though the corresponding effect on CO emissions is not summarized.^{2,3} However, data are presented showing the same qualitative trend as Figure 7-1, i.e., changes in air/fuel contacting that decrease NO_x cause an increase in CO.⁵ For example, when modifications were made causing NO_x to decrease from 2250 ppm to 900 ppm, CO increased from 140 ppm to more than 1000 ppm.

Low NO_x Burners. As with LEA and air/fuel contacting, the primary tradeoff in low NO_x burners is between NO_x and CO emissions.¹ Tests were made on a regenerative end-port furnace producing between 154 and 192 tons of glass/day. The effect of "staged combustion" and flue gas recirculation, which were two of the measures taken to reduce NO_x, are shown in Figure 7-2. The "staged air proportion" in this figure refers to the proportion of the total combustion air that is taken from the flue gas and introduced downstream of the burner but within the furnace (see Figure 5-8). The greater the proportion of staged air, the lower the expected peak flame temperature would be, and, therefore, the lower the NO_x emissions, all else being equal. The oxygen concentration was varied in a series of tests and is shown as a parameter in Figure 7-2. Figure 7-2 shows that NO_x emissions decrease and CO emissions remain essentially constant, with decreasing oxygen concentration.

For a given oxygen concentration, the NO_x emissions decrease, and CO emissions are relatively constant, with increasing proportion of staged air. This suggests negligible

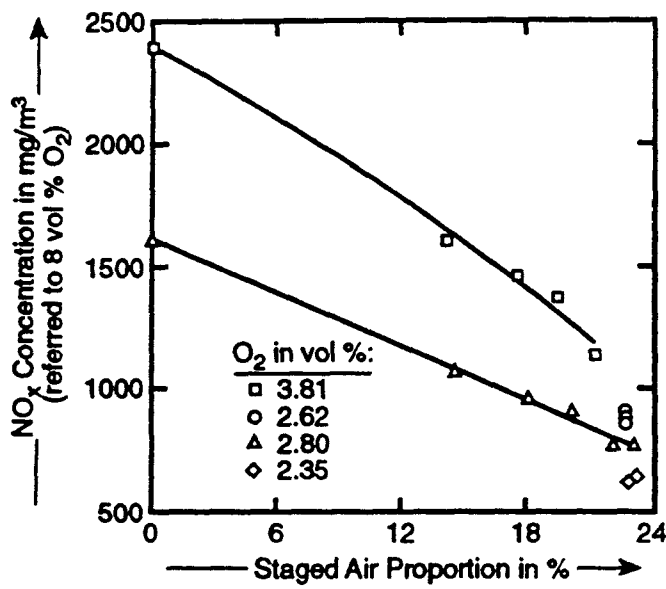

(a) NO_x concentration.

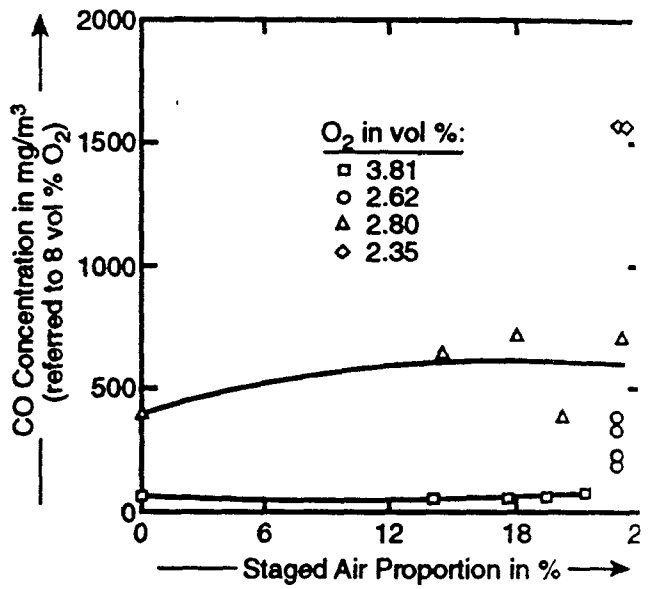

(b) CO concentration.

Figure 7-2. Concentration of the flue gas as a function of the staged-air proportion (left side fired) from an end-fired regenerative furnace.¹

impact on CO emissions, at least for this particular retrofit low NO_x burner.

Oxy firing. The impact of oxy-firing on air emissions other than NO_x is reported in Reference 6. The results of stack tests done on a 340 tons/day side port regenerative furnace before and after conversion to oxy-firing is shown in Table 7-1. In addition to a substantial decrease in NO_x, particulate, CO, and CH₄ emissions decreased. Particulate emissions decrease because the higher flame temperatures produce fewer unburned hydrocarbons.⁷ Only SO_x emissions increased. The authors state that SO_x emissions could be reduced to levels achieved before oxy-firing by changes in the batch formulation. The reduction in CO and CH₄ emissions suggests more complete combustion. The decrease in particulates is possibly a consequence of the greatly reduced gas velocity across the melt (due to the absence of nitrogen in the combustion air) which carries fewer fine particles out of the furnace.

7.1.2.2 Process Modifications.

Cullet preheat. Cullet preheaters are designed to increase the overall thermal efficiency of the glass manufacturing process by transferring heat that would otherwise be lost in the flue gas to the cullet. The Teichmann and Tecogen systems use direct contact heat transfer, while the Zippe system uses indirect heating. This affects the air emissions since direct contact may allow some contaminants in the flue gas to be adsorbed by the cullet but may increase particulate emissions since fine dust in the cullet can be carried away by the flue gas.

The Teichmann system has been installed on a 220 tons/day regenerative furnace in Weigand, Germany.^{8,9} No quantitative results are provided on the impact of the preheater on emissions other than NO_x, though "the cullet preheater is an effective filter for dust dislodged during on-line cleaning."¹⁰ Measurements indicated that the preheater actually removed about half the particulate from the furnace emissions. However, dust in the cullet itself was entrained back into the exiting flue gas, so that the net effect of the preheater on particulates leaving the stack is unclear. Data are provided on SO_x emissions while the preheater was operating.¹¹ These averaged about 2.2 lb SO_x/ton glass (around 200 ppm). Though no comparison to operation without the preheater is given, the statement is made that ". . . preheater is reducing SO_x emissions."¹²

Finally, results on an indirect cullet preheat system at Vetropak AG in Switzerland show that indirect heating eliminates possible entrainment of dust from the cullet.¹³ As discussed above, this apparently does not occur in the Techmann system.⁹ It is also

TABLE 7-1. EFFECT OF OXY-FIRING ON AIR EMISSIONS⁶

Parameter	Conventional firing (lb/ton glass pulled)	Oxy-firing (lb/ton glass pulled)
Particulate	1.19	0.884
NO _x	5.03	0.812
SO _x	0.612	0.968
CO	0.08	0.003
CH ₄	0.02	0.008

suggested that HF, HCl, and sulfur can be adsorbed in *direct* contact systems and that, while this may be an advantage in eliminating emissions of these compounds, it adversely affects glass quality.¹⁴

Electric boost. As a first approximation, it can be assumed that all emissions from glass melting, including NO_x (Section 5.3.2), are reduced in direct proportion to the percent of the furnace energy supplied electrically. Quantitative estimates of these emissions, including SO_x, acid gases, and particulates, are not available.

In addition, electric boost generates additional emissions and wastes associated with the production and distribution of electricity if it is generated from the combustion of fossil fuel. These are not considered here, though they may be large.

7.1.2.3 Postcombustion Modifications.

Selective catalytic reduction. The injection of ammonia into the flue gas from a glass furnace inevitably results in some unreacted ammonia and some byproducts (e.g., NH₃, Cl₂, (NH₄)₂SO₄) in stack emissions. Such emissions generally increase with time as the catalyst ages. In most SCR applications, unreacted ammonia ("ammonia slip") is kept below 20 to 40 ppm by controlling the injection rate of ammonia. Much lower values, of the order of 1 to 5 ppm, are reported for boilers.¹⁵ However, a "maximum" ammonia slip of 10 to 30 ppm is reported for an SCR unit installed on a glass furnace in Germany.¹⁶ A value of "below" 30 ppm for an SCR unit on another glass furnace in Germany was reported.¹⁷ The injection of ammonia may increase stack particulate emissions due to the formation of ammonium sulfate/bisulfate and ammonium chloride, though there is of course a corresponding stoichiometric reduction in gaseous SO_x and HCl emissions. There is potential with SCR for a solid waste disposal problem of spent catalyst, though this can often be returned to the vendor to be reactivated.¹⁸

Assuming 68 scfm of flue gas per ton of glass produced (see footnote b of Table 5-8), an ammonia slip of 10 ppm would result in the following emissions from the three model plants in Table 6-1:

Plant size (ton/day)	Emissions of ammonia (lb/day)
50	2.3
250	11.6
750	34.7

Selective noncatalytic reduction. As with SCR, the SNCR process generates ammonia slip and byproduct salts from the acidic components of the flue gas. For PPG's proprietary SNCR process, ammonia slip is reported as 39 ppm.¹⁹ CO emissions are less than 1 ppm and particulates 0.065 gr/dscf. Values before installation of the system are not reported.

AFG systematically tested the effect of the ammonia injection rate on NO_x, CO, SO₂, particulate, and NH₃ emissions at their Victorville, CA, plant.²⁰ Table 7-2 presents the results, which provide a direct measure of the effect of ammonia injection in this Exxon De-NO_x[®] unit on NO_x, SO₂, total particulate, and CO. Two comparisons can be made to measure this effect. The first is to compare the test done on 2/25/88 with the series of tests on 2/23/88. The second is to compare the tests done on 6/7/88 with and without ammonia injection. Fluctuations in firing, glass production, flue gas rates and flue gas temperatures may be responsible for the wide variation in carbon monoxide and sulfur dioxide levels. The data indicate that ammonia injection in this SNCR process

- has no significant effect on total particulate emissions,
- slightly increases CO emissions, and
- slightly decreases SO₂ emissions

and ammonia slip (unreacted ammonia emissions) increases with ammonia injection rate.

Operating experience, primarily in boilers, has identified several concerns with both ammonia and urea-based SNCR processes. The most frequently reported is the buildup of ammonium bisulfate scale, which can also be emitted as a particulate. Because natural gas, which has very little sulfur, is used in most glass furnaces, such sulfate formation is negligible in glass furnace flue gas ducts. Even when sulfur-containing fuels such as fuel oil are used, vendors report that process modifications have been made to minimize problems of sulfate scale deposition.²¹ SNCR processes also appear to convert some NO to N₂O.²² The rate of N₂O formation is a weak function of both the reactant and NO concentration (ammonia or urea/NO ratio). However, N₂O formation seems to be inherently more prevalent in systems using urea than those using ammonia.²³ SNCR

TABLE 7-2. SUMMARY OF AFG-VICTORVILLE TESTS OF SNCR²²

	NO _x		SO ₂		Total particulates		CO		NH ₃	
	lb/ton glass	ppm	lb/ton glass	ppm	lb/ton glass	gr/dscf	lb/ton glass	ppm	lb/ton glass	ppm
Uncontrolled emissions ^a										
6/7/88	13.1	930	0.601	30.7	0.62	0.0375	0.061	7.1	NA	NA
6/1-2/92 ^b	13.1 ^c	733 ^c	0.624	25.2	0.70	0.0331	0.648	58.7	NA	NA
2/25/88	14.6	1,103	0.787	42.0	0.51	0.0325	0.099	12.3	NA	NA
Controlled emissions										
6/7/88 ^d	8.42	605	.049	25.6	0.56	0.0342	0.081	9.7	NR	NR
2/23/88 ^e										
• 775 ft ³ /hr NH ₃	11.5	924	0.706	40.6	0.517 ^f	0.0335	0.650	85.6	0.046	9.89
• 900 ft ³ /hr NH ₃	10.7	828	0.627	34.8	NR	†	0.884	112	0.081	16.9
• 1030 ft ³ /hr NH ₃	11.7	838	0.701	36.1	NR	NR	0.261	30.8	0.113	21.8
• 1160 ft ³ /hr NH ₃	10.7	821	0.660	36.2	NR	NR	0.148	18.6	0.164	34.0

NA = Not applicable.

NR = Not reported.

^a These measurements were made with the ammonia injection cut off, all other operating parameters were then kept the same in subsequent tests. The dates given refer to emission test dates. Emissions are normalized using a glass production of 450 ton/day.

^b No tests were made downstream of SNCR unit on these dates.

^c The flue gas flow rate was roughly one-third higher for this test than for the 6/7/88 tests, accounting for the lower NO_x concentration.

^d Ammonia injected for these tests at 1100 ft³/hr.

^e Four tests were made on this date to test the effect of NH₃ concentration. The values given are four NH₃ injection rates in ft³/hr.

^f Taken from 2/24/88 data at 775 ft³/hr ammonia.

processes may also increase CO concentrations in the flue gas, though the increase for urea-based systems is apparently much less than that due to combustion modifications such as overfire air and substoichiometric combustion air.²⁴ One reference states that ammonia injection has no effect on CO emissions.²⁵ Interestingly, the intentional addition of CO in the reaction zone of the process broadens the operating temperature for urea-based systems, even at CO concentrations as low as 500 ppm, although it increases N₂O emissions.²⁶ However this does not imply that stack emissions of carbon monoxide increase. Some data on other combustion systems suggest that in some cases the effect of ammonia injection on CO emissions is negligible and that some data spread is inevitable due to varying combustion conditions.

7.2 ENERGY IMPACTS

7.2.1 Combustion Modifications

7.2.1.1 Modifications to Existing Burners.

Low Excess Air and Air/Fuel Contacting. Data suggest that LEA operation and changes in air/fuel contacting do not significantly affect furnace energy usage (MM Btu/ton glass produced).²⁷ Based on this, these two combustion modifications are assumed to have negligible energy impacts.

7.2.1.2 Low NO_x Burners. The Körtig burner results in energy savings by reducing air infiltration, but no quantitative results are presented.²⁸ Such a claim would be difficult to quantify since air infiltration is highly site specific. Such burners may be more efficient than others and would therefore save energy. However, a direct comparison cannot be made with the existing data.

7.2.1.3 Oxy-firing. Oxy-firing results in lower energy consumption (MM Btu/ton glass produced). This is, in fact, one of the primary reasons for its use. Figure 7-3 shows the "available heat" as a function of flue gas temperature for various levels of oxygen.⁷ Available heat is defined as the gross heating value of the fuel minus the heat carried away in the flue gas. Fuel savings of 15 percent for oxy-firing on a 75 tons/day have been estimated for an end-fired regenerative furnace.²⁹ Production during the test was 58 tons/day. Further, at essentially the same fuel usage rate, glass production increased from 62.7 to 75.8 tons/day(21 percent), as shown below:

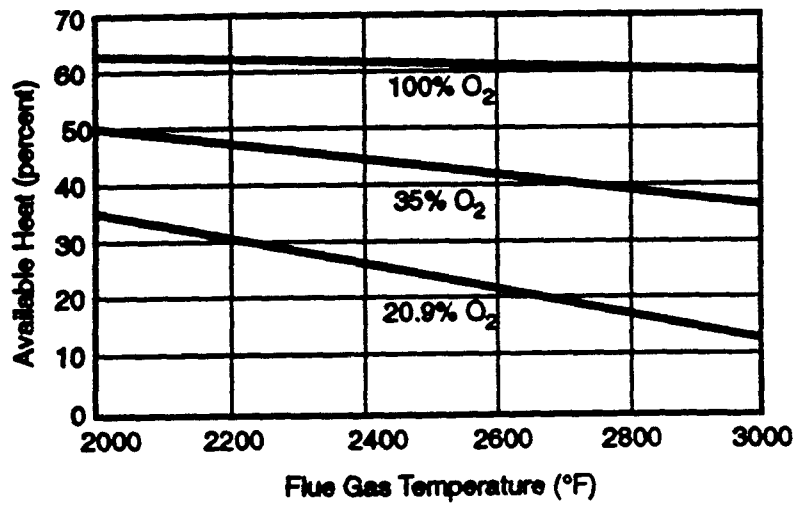

Figure 7-3. Available heat as a function of flue gas temperature.⁷

	Air-firing	Oxy-firing
Production (tons/day)	62.7	75.8
Fuel usage (MM Btu/hr)	13.7	13.6

This corresponds to 30 to 40 percent energy savings (Figure 7-4) for regenerative glass furnaces, but absolute values (MM Btu/ton glass) are not provided.³⁰ For the Gallo plant, natural gas usage was 9.5 percent lower than with air-firing (3.74 MM Btu/ton with air-firing, 3.39 MM Btu/ton for oxy-firing).³² This energy savings is due to two principal factors. First, there is reduced radiation from the melting furnace to the regenerator due to reduced port area. The port area can be reduced because the volumetric flow rate of the flue gas is reduced. Second, the greatly reduced nitrogen content of the combustion air means less energy lost to the flue gas. There is also an energy savings due to a lower flue gas flow rate which requires less electrical energy for the flue gas fan. However, energy or net utility cost savings are rare when the cost of oxygen is taken into account.³³

7.2.2 Process Modifications

7.2.2.1 Cullet Preheat. Cullet preheaters are designed to recover heat from the flue gas and therefore will reduce the energy consumption in glass melting.

The Teichmann cullet preheater accounts for 8 to 12 percent of the total energy saved by their Low NO_x Melter[®], which also incorporates other energy savings features.^{8,9} Insufficient information is given to determine absolute energy savings associated with the cullet preheater alone.

A 20 percent decrease in energy consumption for the Tecogen preheater (a savings of 1 MM Btu/ton, from 5 to 4 MM Btu/ton) is estimated.³⁴ Actual tests showed a slightly lower energy savings (0.86 instead of 1 MM Btu/ton) at a production rate of 257 tons/day. An 7 to 10 percent reduction in energy consumption is reported for a 240-tons/day furnace equipped with a Tecogen cullet preheater processing about 80 tons cullet/day, i.e. about one-third of the furnace feed.³⁵ No absolute values are given.

Energy consumption would decrease by 12 percent on a 300-tons/day furnace which uses 100 percent cullet feed (no virgin batch ingredients) if all the cullet were

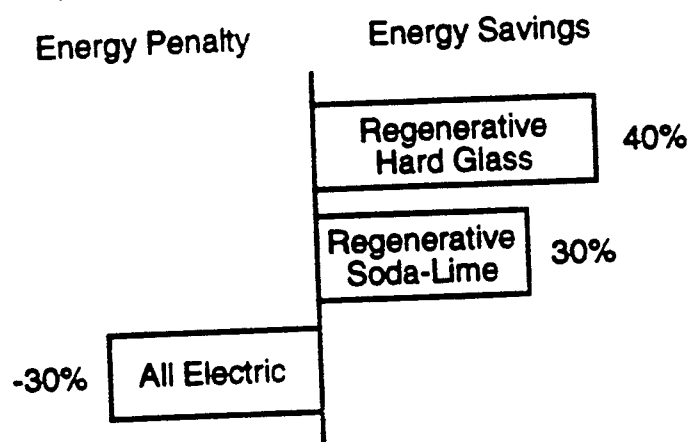

Figure 7-4. Energy impact of oxy-firing.²⁷

preheated.³⁶ This calculation is extrapolated from actual results obtained at the Vetropak plant when 25 percent of the cullet was preheated. No absolute values of energy reduction (MM Btu/ton) are given.

7.2.2.2 Electric Boost. Figure 7-4 shows the energy penalty associated with electric boost. The relationship between electric boost and glass production has been estimated to be 25 tons glass/day per 1000 kVA (or 1 ton glass per 800 kWh).³⁷ As discussed in Section 5.3.2, electric boost is more efficient than gas firing, i.e., more of the theoretical energy input to the melt electrically is actually transferred to the melt. This efficiency value for electric boost is roughly 70 percent. One reference states this as 73 percent compared to about 30 to 35 percent for gas firing (see Section 3.2).²⁴ However, the production and distribution of electricity from fossil fuels is only about 20 to 25 percent efficient, making electricity from fossil fuels less efficient than gas firing. Thus, the energy impact of electric boost would be to increase the demand for electricity, which is inherently less efficient in delivering energy to the glass melt from the original fuel than gas firing.

The electrodes used for electric boosting are made of molybdenum. It is not known if these pose a solid waste disposal problem.

7.2.3 Postcombustion Modifications

7.2.3.1 Selective Catalytic Reduction. There is some pressure drop across the SCR catalyst that will require additional electrical energy for the flue gas fan. Typically, this pressure drop is of the order of 5 to 10 in. H₂O. For a pressure drop of 10 in. H₂O, and using a value of 68 scfm per ton/day of glass (see footnote b of Table 5-8) and a fan efficiency of 60 percent, calculations can be made using the following equation:

$$\text{Power (KW)} = \frac{1.17 \times 10^{-4} Q \Delta P}{\epsilon}$$

where

- Q = gas flow rate, scfm
- ΔP = pressure drop, in H₂O
- ε = fan efficiency, 0 < ε < 1.

The results are shown below:

<u>Plant size (tons/day)</u>	<u>Fan energy (kW)</u>
50	6.6
250	33.2
750	99.4

Because dust can foul the catalyst, an SCR unit would typically be installed downstream of a particulate control device, such as an electrostatic precipitator (ESP) (e.g., Reference 16; see also Figure 5-25 in Section 5.4.2). If the temperature at this point is below 350 to 500 °C (660 to 930 °F), the gas may need to be reheated with gas burners. This highly site-specific energy impact is not considered further here.

7.2.3.2 Selective Noncatalytic Reduction. SNCR introduces no additional pressure drop in flue gas. Energy consumption in the SNCR process is related to the pretreatment and injection of ammonia-based reagents and their carrier gas or liquids. Liquid ammonia or urea are injected in liquid form at high pressures to ensure efficient droplet atomization and dispersion. In some Thermal DeNO_x installations, anhydrous ammonia is stored in liquid form under pressure. The liquid ammonia must be vaporized with some heat, mixed with carrier gas (air or steam) and then injected for adequate mixing. The amount of electricity used depends on whether the process uses air or steam for carrier gas. If steam is used, less electricity is needed but power consumption must take into consideration the amount of steam used.

7.3 REFERENCES

1. Barklage-Hilgefort, H., and W. Sieger. Primary Measures for the NO_x Reduction on Glass Melting Furnaces. *Glastech.* 62(5):151. 1989.
2. Abbasi, H.A., and D.K. Fleming. Development of NO_x Control Methods for Glass Melting Furnaces. Gas Research Institute. Final Report No. GRI-87/0202. August 1987.
3. Abbasi, H.A., and D.K. Fleming. Combustion Modifications for Control of NO_x Emissions from Glass Melting Furnaces. *Ceram. Eng. Sci. Proc.* 9(3-4):168-177. 1988.
4. Kircher, U. *Gas Wärme Int.* 35(4):207-212. 1986.
5. Ref. 2, pp. 41, 90.
6. Moore, R.D., and J.T. Brown. Conversion of a Large Container Furnace from Regenerative Firing to Direct Oxy Fuel Combustion. 1991 Glass Problems Conference. November 12-13, 1991. American Ceramic Society. Westerville, OH. p. 6. 1992.
7. Baukal, C.E., P.B. Eleazer, and L.K. Farmer. Basis for Enhancing Combustion by Oxygen Enrichment. *Ind. Heating.* 22. February 1992.
8. Moore, R.H. LoNO_x[™] Glass Melting Furnace. *Ceram. Eng. Sci. Proc.* 11(1-2):89-101. 1990.
9. Moore, R.H. LoNO_x Melter Shows Promise. *Glass Indust.* p. 14. March 1990.
10. Ref. 9, p. 16.
11. Ref. 9, p. 18.
12. Ref. 9, p. 17.
13. Zippe, B.H. Reliable Cullet Preheater for Glass Furnaces. *Ceram. Eng. Sci. Proc.* 12(3-4):550-555. 1991.
14. Ref. 15, p. 553.
15. Maier, H., and P. Dahl. Operating Experience with Tail-end and High Dust DeNO_x Techniques at the Power Plant of Heilbronn. Joint EPA/EPRI Symposium on Stationary Combustion NO_x Control. March 1991.
16. Grove, M., and W. Strum. NO_x Abatement System: Using Molecular Sieve Catalyst Modules for a Glass Melting Furnace. *Ceram. Eng. Sci. Proc.* 10(3-4):330. 1989.

17. Letter from Gocht, Lurgi, Frankfurt, Germany, to Spivey, J.J. Research Triangle Institute, Research Triangle Park, NC. April 29, 1992.
18. Smith, J.C., and M.J. Wax. Selective Catalytic Reduction Controls to Abate NO_x Emissions. Institute of Clean Air Companies. Washington, DC. September 1992. p. 18.
19. Letter and attachments from Osheka, J.W., PPG Industries, Inc., Pittsburgh, PA, to Jordan, B.C., EPA/OAQPS, Research Triangle Park, NC. September 1, 1992. Response to Section 114 letter on glass manufacturing.
20. Letter and attachments from Robinson, J.R., AFG Industries, Inc., Kingsport, TN, to Jordan, B.C., EPA/OAQPS, Research Triangle Park, NC. August 20, 1992. Response to Section 114 letter on glass manufacturing.
21. Mincy, J.E. SNCR Technology: The Next Generation: presented at NO_x V Conference. February 10-11, 1992. Long Beach, CA. Council of Industrial Boilers. Burke, VA.
22. Kokkinos, A., J.E. Cichanowicz, R.E. Hall, and C.B. Sedman. Stationary Combustion NO_x Control: A Summary of the 1991 Symposium. J. Air Waste Manage. Assoc. p. 1255. 1991.
23. Muzio, L. N₂O Formation in Selective Non-Catalytic Reduction Processes in Proc. 1991 Joint Symposium on Stationary Combustion No_x Control. NTIS. 1991.
24. Moore, R.D., and R.E. Davis. Electric Furnace Application for Container Glass. Ceram. Eng. Sci. Proc. 8(3-4):188-199. 1987.
25. Haas, G.A. Selective Noncatalytic Reduction (SNCR): Experience with the Exxon Thermal DeNO_x Process. Presented at the NO_x Control V Conference, Council of Industrial Boiler Owners. Long Beach, CA. February 10-11, 1992.
26. Teixeira, D. Widening the Urea Temperature Window. In Proc. 1991 Joint Symposium on Stationary Combustion NO_x Control. NTIS. 1991.
27. Ref. 3, pp. 42, 179, 187.
28. Sieger, W. Development of Reduced NO_x Burners. Glass Tech. 31(1):6. 1990.
29. Kobayashi, H., G.B. Tuson, E.J. Lauwers. NO_x Emissions from Oxy-Fuel Fired Glass Melting Furnaces. Paper presented at the European Society of Glass Sciences and Technology Conference on Fundamentals of the Glass Manufacturing Process, Sheffield, England. September 9-11, 1991. Union Carbide. Tarrytown, NY. p. 10.

30. Brown, J.T. Development—History and Benefits of Oxygen-Fuel Combustion for Glass Furnaces. Corning Glass. Corning, NY. Presented at Latin American Technical Symposium on Glass Manufacture. Sao Paulo, Brazil. November 18, 1991. p. 21.
31. Ref. 30, p. 22.
32. Ref. 6, p. 5.
33. Brown, J.T. 100% Oxygen Fuel Combustion for Glass Furnaces. Ceram. Eng. Sci. Proc. 12(3-4):601. 1991.
34. De Saro, R., L.W. Donaldson and C.W. Hibscher. Fluidized Bed Glass Batch Preheater, Part II. Ceram. Eng. Sci. Proc. 8(3-4):171-180. 1987
35. Cole, W.E., F. Becker, L. Donaldson, S. Panahe. Operation of a Cullet Preheating System. Ceram. Eng. Sci. Proc. 11(1-2), 53-68. 1990.
36. Ref. 13, p. 554.
37. Ref. 2, p. 39.

TECHNICAL REPORT DATA
(Please read Instructions on the reverse before completing)

1. REPORT NO. EPA-453/R-94-037		2.	3. RECIPIENT'S ACCESSION NO.	
4. TITLE AND SUBTITLE Alternative Control Techniques Document - NO _x Emissions from Glass Manufacturing			5. REPORT DATE June 1994	
			6. PERFORMING ORGANIZATION CODE	
7. AUTHOR(S) William J. Neuffer			8. PERFORMING ORGANIZATION REPORT NO.	
9. PERFORMING ORGANIZATION NAME AND ADDRESS			10. PROGRAM ELEMENT NO.	
			11. CONTRACT/GRANT NO.	
12. SPONSORING AGENCY NAME AND ADDRESS U. S. Environmental Protection Agency Emission Standards Division (MD-13) Office of Air Quality Planning & Standards Research Triangle Park, North Carolina 27711			13. TYPE OF REPORT AND PERIOD COVERED	
			14. SPONSORING AGENCY CODE	
15. SUPPLEMENTARY NOTES EPA Project Manager: William J. Neuffer (919) 541-5435				
16. ABSTRACT This alternative control/techniques (ACT) document describes available control techniques for reducing NO _x emissions from glass furnaces. Control techniques include low NO _x burners, oxy-firing, modified furnace, cullet preheat, electric boost, selective catalytic reduction, and selective noncatalytic reduction. Achievable controlled NO _x emission levels, costs, and cost effectiveness and environmental and energy impacts for these controls are discussed. NO _x formation and uncontrolled NO _x emission levels are also discussed.				
17. KEY WORDS AND DOCUMENT ANALYSIS				
a	DESCRIPTORS	b. IDENTIFIERS/OPEN ENDED TERMS	c. COSATI Field/Group	
	Glass Furnaces Nitrogen Oxide Emissions NO _x Emission Controls Low NO _x Burners Oxy-firing Selective Catalytic Reduction Selective Noncatalytic Reduction			
18. DISTRIBUTION STATEMENT		19. SECURITY CLASS (This Report) Unclassified	21. NO. OF PAGES -- 154	
		20 SECURITY CLASS (This page) Unclassified	22. PRICE	

U.S. Environmental Protection Agency
Region 5, Library (PL-12J)
77 West Jackson Boulevard, 12th Floor
Chicago, IL 60604-3590