

United States  
Environmental Protection  
Agency

Office of Air Quality  
Planning and Standards  
Research Triangle Park NC 27711

EPA-453/R-93-034  
September 1993

---

Air

---



# Alternative Control Techniques Document -- NOx Emissions from Process Heaters (Revised)

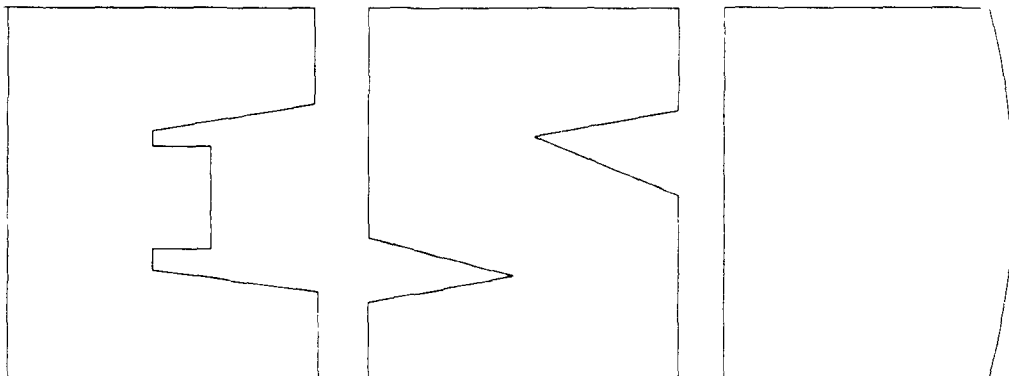

**Alternative Control  
Techniques Document--  
NO<sub>x</sub> Emissions from  
Process Heaters  
(Revised)**

**Emission Standards Division**

**U.S. ENVIRONMENTAL PROTECTION AGENCY  
Office of Air and Radiation  
Office of Air Quality Planning and Standards  
Research Triangle Park, North Carolina 27711  
September 1993**

U.S. Environmental Protection Agency  
Region 5, L-12J (PL-12J)  
77 West Jackson Boulevard, 12th Floor  
Chicago, IL 60604-3590

## TABLE OF CONTENTS

<u>Section</u>	<u>Page</u>
1.0 INTRODUCTION . . . . .	1-1
2.0 SUMMARY . . . . .	2-1
2.1 UNCONTROLLED NO <sub>x</sub> EMISSIONS . . . . .	2-1
2.2 AVAILABLE NO <sub>x</sub> EMISSION CONTROL TECHNIQUES . . . . .	2-4
2.3 CAPITAL COSTS AND COST EFFECTIVENESS . . . . .	2-5
2.4 IMPACTS OF NO <sub>x</sub> CONTROLS . . . . .	2-22
3.0 PROCESS HEATER DESCRIPTION AND INDUSTRY CHARACTERIZATION . . . . .	3-1
3.1 PROCESS HEATER DESCRIPTION . . . . .	3-1
3.1.1 Heated Feed . . . . .	3-2
3.1.2 Reaction Feed . . . . .	3-2
3.1.3 Process Heater Design Parameters . . . . .	3-2
3.1.3.1 Combustion Chamber Set-Ups . . . . .	3-2
3.1.3.2 Combustion Air Supply . . . . .	3-3
3.1.3.3 Tube Configurations . . . . .	3-6
3.1.3.4 Burners . . . . .	3-6
3.2 INDUSTRY CHARACTERIZATION . . . . .	3-10
3.2.1 Process Heaters in Use . . . . .	3-10
3.2.2 Process Heater Energy Consumption . . . . .	3-12
3.3 REFERENCES FOR CHAPTER 3 . . . . .	3-19
4.0 CHARACTERIZATION OF NO <sub>x</sub> EMISSIONS . . . . .	4-1
4.1 FORMATION OF NO <sub>x</sub> . . . . .	4-1
4.1.1 Thermal NO <sub>x</sub> Formation . . . . .	4-1
4.1.2 Fuel NO <sub>x</sub> Formation . . . . .	4-4
4.1.3 Prompt NO <sub>x</sub> Formation . . . . .	4-6
4.2 FACTORS AFFECTING UNCONTROLLED NO <sub>x</sub> EMISSIONS . . . . .	4-6
4.2.1 Heater Design Parameters . . . . .	4-6
4.2.1.1 Fuel Type . . . . .	4-7
4.2.1.2 Burner Type . . . . .	4-8
4.2.1.3 Combustion Air Preheat . . . . .	4-10
4.2.1.4 Firebox Temperatures . . . . .	4-10
4.2.1.5 Draft Type . . . . .	4-12
4.2.2 Heater Operating Parameters . . . . .	4-14
4.2.2.1 Excess Air . . . . .	4-14
4.2.2.2 Burner Adjustments . . . . .	4-15
4.3 UNCONTROLLED NO <sub>x</sub> EMISSION FACTORS AND MODEL HEATERS . . . . .	4-15
4.3.1 Uncontrolled NO <sub>x</sub> Emissions . . . . .	4-17
4.3.2 Model Heaters . . . . .	4-25
4.4 REFERENCES FOR CHAPTER 4 . . . . .	4-30

TABLE OF CONTENTS (continued)

<u>Section</u>		<u>Page</u>
5.0	NO <sub>x</sub> CONTROL TECHNIQUES . . . . .	5-1
5.1	COMBUSTION CONTROLS . . . . .	5-1
5.1.1	Low Excess Air . . . . .	5-2
5.1.2	Combustion Air Preheat . . . . .	5-4
5.1.3	Use of Air Lances to Achieve Staged Combustion . . . . .	5-4
5.1.4	Staged-Air, Low-NO <sub>x</sub> Burners . . . . .	5-9
5.1.5	Staged-Fuel, Low-NO <sub>x</sub> Burners . . . . .	5-15
5.1.6	Flud Gas Recirculation . . . . .	5-17
5.1.7	Ultra-Low NO <sub>x</sub> Burners . . . . .	5-21
5.1.8	Radiant Burners . . . . .	5-23
5.2	SELECTIVE NONCATALYTIC REDUCTION . . . . .	5-24
5.2.1	Exxon Thermal DeNO <sub>x</sub> <sup>®</sup> (Ammonia Injection) . . . . .	5-27
5.2.1.1	Process Description (Thermal DeNO <sub>x</sub> <sup>®</sup> ) . . . . .	5-29
5.2.1.2	Factors Affecting Thermal DeNO <sub>x</sub> <sup>®</sup> Performance . . . . .	5-31
5.2.1.3	NO <sub>x</sub> Reduction Efficiency Using Thermal DeNO <sub>x</sub> <sup>®</sup> . . . . .	5-32
5.2.1.4	Ammonia Slip Considerations For Thermal DeNO <sub>x</sub> <sup>®</sup> . . . . .	5-32
5.2.2	Nalco Fuel Tech NO <sub>x</sub> OUT <sup>®</sup> (Urea Injection) . . . . .	5-32
5.2.2.1	Process Description (NO <sub>x</sub> OUT <sup>®</sup> ) . . . . .	5-33
5.2.2.2	Factors Affecting NO <sub>x</sub> OUT <sup>®</sup> Performance . . . . .	5-35
5.2.2.3	NO <sub>x</sub> Emission Reduction Efficiency Using NO <sub>x</sub> OUT <sup>®</sup> . . . . .	5-36
5.2.2.4	Ammonia Slip Considerations For NO <sub>x</sub> OUT <sup>®</sup> . . . . .	5-36
5.3	SELECTIVE CATALYTIC REDUCTION . . . . .	5-36
5.3.1	Process Description (SCR) . . . . .	5-37
5.3.2	Factors Affecting SCR Performance . . . . .	5-40
5.3.3	NO <sub>x</sub> Emission Reduction Efficiency Using SCR . . . . .	5-43
5.4	SPECIAL CONSIDERATIONS . . . . .	5-46
5.5	ACHIEVABLE NO <sub>x</sub> EMISSION REDUCTIONS . . . . .	5-50
5.6	REFERENCES FOR CHAPTER 5 . . . . .	5-58
6.0	CONTROL COSTS . . . . .	6-1
6.1	CAPITAL AND ANNUAL COSTS METHODOLOGIES . . . . .	6-2
6.1.1	Costs of LNB's . . . . .	6-2
6.1.1.1	Capital Costs of LNB's . . . . .	6-2
6.1.1.2	Operating Costs of LNB's . . . . .	6-4
6.1.2	Cost of ULNB's . . . . .	6-5
6.1.2.1	Capital Costs of ULNB's . . . . .	6-5
6.1.2.2	Operating Costs of ULNB's . . . . .	6-5



TABLE OF CONTENTS (continued)

<u>Section</u>		<u>Page</u>
6.1.3	Costs of SNCR . . . . .	6-6
	6.1.3.1 Capital Costs of SNCR . . . . .	6-6
	6.1.3.2 Operating Costs of SNCR . . . . .	6-6
6.1.4	Costs of SCR . . . . .	6-7
	6.1.4.1 Capital Costs of SCR . . . . .	6-7
	6.1.4.2 Operating Costs of SCR . . . . .	6-7
6.1.5	Costs of FGR . . . . .	6-8
	6.1.5.1 Capital Costs of FGR . . . . .	6-8
	6.1.5.2 Operating Costs of FGR . . . . .	6-9
6.1.6	Costs of LNB's Plus SNCR . . . . .	6-9
	6.1.6.1 Capital Costs of LNB's Plus SNCR . . . . .	6-9
	6.1.6.2 Operating Costs of LNB's Plus SNCR . . . . .	6-10
6.1.7	Costs of LNB's Plus SCR . . . . .	6-10
	6.1.7.1 Capital Costs of LNB's Plus SCR . . . . .	6-10
	6.1.7.2 Operating Costs of LNB's Plus SCR . . . . .	6-10
6.1.8	Costs of ND-to-MD Conversion . . . . .	6-10
	6.1.8.1 Capital Costs of ND-to-MD Conversion . . . . .	6-10
	6.1.8.2 Operating Costs of ND-to-MD Conversion . . . . .	6-11
6.2	TOTAL ANNUAL COST FOR MODEL HEATERS . . . . .	6-11
	6.2.1 Control Costs for the ND Gas-Fired, Low- and Medium-Temperature Model Heaters . . . . .	6-12
	6.2.2 Control Costs for MD Gas-Fired, Low- and Medium-Temperature Model Heaters . . . . .	6-12
	6.2.3 Control Costs for ND Oil-Fired, Low- and Medium-Temperature Model Heaters . . . . .	6-12
	6.2.4 Control Costs for MD Oil-Fired, Low- and Medium-Temperature Model Heaters . . . . .	6-18
	6.2.5 Control Costs for the Olefins Pyrolysis Model Heaters . . . . .	6-18
	6.2.6 Costs for ND-to-MD Conversion . . . . .	6-18
6.3	COST EFFECTIVENESS OF NO <sub>x</sub> CONTROLS FOR PROCESS HEATERS . . . . .	6-18
6.4	COST EFFECTIVENESS OF RADIANT BURNERS . . . . .	6-32
6.5	REFERENCES FOR CHAPTER 6 . . . . .	6-34
7.0	ENVIRONMENTAL AND ENERGY IMPACTS . . . . .	7-1
	7.1 AIR POLLUTION IMPACTS . . . . .	7-1
	7.1.1 NO <sub>x</sub> Emission Reductions . . . . .	7-1

TABLE OF CONTENTS (continued)

<u>Section</u>	<u>Page</u>
7.1.2 Emissions Trade-Offs . . . . .	7-3
7.1.2.1 Impacts on HC and CO Emissions from the Use of LNB's, ULNB's and FGR . . . . .	7-3
7.1.2.2 Impacts on NH <sub>3</sub> , N <sub>2</sub> O, CO, and PM Emissions from the Use of SNCR and SCR . . . . .	7-10
7.2 SOLID WASTE IMPACTS . . . . .	7-14
7.3 ENERGY IMPACTS . . . . .	7-15
7.4 REFERENCES FOR CHAPTER 7 . . . . .	7-17
APPENDIX A: REFINERY PROCESS HEATER INVENTORY . . . . .	A-1
APPENDIX B: CURRENT AND FUTURE NO <sub>x</sub> OUT <sup>®</sup> APPLICATIONS . . . . .	B-1
APPENDIX C: LIST OF PROCESS HEATER NO <sub>x</sub> CONTROL RETROFITS FOR MOBIL TORRANCE REFINERY . . . . .	C-1
APPENDIX D: FOSTER WHEELER PROCESS HEATER SCR INSTALLATIONS . . . . .	D-1

LIST OF TABLES

	<u>Page</u>
TABLE 2-1. UNCONTROLLED EMISSION FACTORS FOR MODEL HEATERS . . . . .	2-3
TABLE 2-2. REDUCTION EFFICIENCIES FOR CONTROL TECHNIQUES APPLIED TO NATURAL GAS- AND REFINERY FUEL GAS-FIRED PROCESS HEATERS . . . . .	2-6
TABLE 2-3. REDUCTION EFFICIENCIES FOR CONTROL TECHNIQUES APPLIED TO ND AND MD, DISTILLATE AND RESIDUAL OIL-FIRED PROCESS HEATERS . . . . .	2-7
TABLE 2-4. MODEL HEATERS: NO <sub>x</sub> EMISSION REDUCTIONS, CAPITAL COSTS, AND COST EFFECTIVENESS FOR ND, NATURAL GAS-FIRED LOW- AND MEDIUM-TEMPERATURE HEATERS . . . . .	2-9
TABLE 2-5. MODEL HEATERS: NO <sub>x</sub> EMISSION REDUCTIONS, CAPITAL COSTS, AND COST EFFECTIVENESS FOR MD, NATURAL GAS-FIRED, LOW- AND MEDIUM-TEMPERATURE HEATERS . . . . .	2-12
TABLE 2-6. MODEL HEATERS: NO <sub>x</sub> EMISSION REDUCTIONS, CAPITAL COSTS, AND COST EFFECTIVENESS FOR ND, OIL-FIRED, LOW- AND MEDIUM-TEMPERATURE HEATERS . . . . .	2-14
TABLE 2-7. MODEL HEATERS: NO <sub>x</sub> EMISSION REDUCTIONS, CAPITAL COSTS, AND COST EFFECTIVENESS FOR MD, OIL-FIRED, LOW- AND MEDIUM-TEMPERATURE HEATERS . . . . .	2-15
TABLE 2-8. MODEL HEATERS: NO <sub>x</sub> EMISSION REDUCTIONS, CAPITAL COSTS, AND COST EFFECTIVENESS FOR ND OLEFINS PYROLYSIS HEATERS . . . . .	2-16
TABLE 3-1. SURVEY OF OPERATING REFINERIES IN THE U.S. . . . .	3-13
TABLE 3-2. MAJOR REFINERY PROCESSES REQUIRING A FIRED HEATER . . . . .	3-14
TABLE 3-3. ENERGY REQUIREMENTS OF MAJOR FIRED HEATER APPLICATIONS IN THE CHEMICAL INDUSTRY . . . . .	3-17
TABLE 3-4. REPORTED APPLICATIONS OF FIRED HEATERS IN THE CHEMICAL MANUFACTURING INDUSTRY . . . . .	3-18

LIST OF TABLES (continued)

	<u>Page</u>
TABLE 4-1. AP-42 ESTIMATES FOR UNCONTROLLED NO <sub>x</sub> EMISSIONS FROM BOILERS AND PROCESS HEATERS . . . . .	4-18
TABLE 4-2. AVERAGE UNCONTROLLED NO <sub>x</sub> EMISSIONS FROM REFINERY PROCESS HEATERS BASED ON EMISSION DATA FROM API . . . . .	4-22
TABLE 4-3. AVERAGE UNCONTROLLED NO <sub>x</sub> EMISSIONS FROM PROCESS HEATERS AT ONE REFINERY INSTALLATION . . . . .	4-24
TABLE 4-4. MODEL HEATERS AND UNCONTROLLED NO <sub>x</sub> EMISSION FACTORS: NATURAL GAS-FIRED, LOW- AND MEDIUM-TEMPERATURE ND WITHOUT PREHEAT . . . . .	4-26
TABLE 4-5. MODEL HEATERS AND UNCONTROLLED NO <sub>x</sub> EMISSION FACTORS: NATURAL GAS-FIRED, LOW- AND MEDIUM-TEMPERATURE MD WITH PREHEAT . . . . .	4-26
TABLE 4-6. MODEL HEATERS AND UNCONTROLLED EMISSION FACTORS: DISTILLATE AND RESIDUAL OIL-FIRED, LOW- AND MEDIUM-TEMPERATURE ND WITHOUT PREHEAT . . . . .	4-31
TABLE 4-7. MODEL HEATERS AND UNCONTROLLED EMISSION FACTORS: DISTILLATE AND RESIDUAL OIL-FIRED, LOW- AND MEDIUM-TEMPERATURE MD WITH PREHEAT . . . . .	4-31
TABLE 4-8. MODEL HEATERS AND UNCONTROLLED EMISSION FACTORS: NATURAL GAS-FIRED AND HIGH-HYDROGEN FUEL GAS-FIRED OLEFINS PYROLYSIS FURNACES . . . . .	4-32
TABLE 5-1. CONTROLLED EMISSIONS FOR STAGED COMBUSTION USING AIR LANCES . . . . .	5-8
TABLE 5-2. CONTROLLED EMISSIONS LEVELS FOR STAGED-AIR LNB'S . . . . .	5-10
TABLE 5-3. STAGED-AIR BURNER NO <sub>x</sub> CONTROL PERFORMANCE AND EMISSION LEVELS . . . . .	5-11
TABLE 5-4. STAGED-FUEL LOW-NO <sub>x</sub> BURNER CONTROLLED NO <sub>x</sub> EMISSION LEVELS . . . . .	5-18

LIST OF TABLES (continued)

	<u>Page</u>
TABLE 5-5. CONTROLLED NO <sub>x</sub> EMISSION LEVELS FOR STAGED-FUEL LOW-NO <sub>x</sub> BURNERS . . . . .	5-19
TABLE 5-6. RADIANT BURNER APPLICATIONS . . . . .	5-25
TABLE 5-7. PARTIAL LIST OF EXXON'S THERMAL DeNO <sub>x</sub> <sup>®</sup> INSTALLATIONS . . . . .	5-30
TABLE 5-8. NALCO FUEL TECH NO <sub>x</sub> OUT <sup>®</sup> PROCESS HEATER APPLICATIONS . . . . .	5-37
TABLE 5-9. CONTROLLED EMISSION FACTORS FOR SCR ADDED TO HEATERS WITH LNB'S . . . . .	5-44
TABLE 5-10. ENERGY REQUIREMENTS OF MAJOR FIRED HEATER APPLICATIONS IN THE CHEMICAL INDUSTRY . . . . .	5-47
TABLE 5-11. MODEL HEATERS: CONTROLLED EMISSIONS FOR ND, NATURAL GAS-FIRED, LOW- AND MEDIUM-TEMPERATURE HEATERS . . . . .	5-52
TABLE 5-12. MODEL HEATERS: CONTROLLED EMISSIONS FOR MD, NATURAL GAS-FIRED, LOW- AND MEDIUM-TEMPERATURE HEATERS . . . . .	5-53
TABLE 5-13. MODEL HEATERS: CONTROLLED EMISSIONS FOR ND OIL-FIRED HEATERS . . . . .	5-54
TABLE 5-14. MODEL HEATERS: CONTROLLED EMISSIONS FOR MD OIL-FIRED HEATERS . . . . .	5-55
TABLE 5-15. MODEL HEATERS: CONTROLLED EMISSIONS FOR ND OLEFINS PYROLYSIS HEATERS . . . . .	5-56
TABLE 6-1. UTILITY, CHEMICAL, AND MAINTENANCE COSTS . . . . .	6-3
TABLE 6-2. COSTS OF CONTROL TECHNIQUES FOR ND NATURAL GAS-FIRED MODEL HEATERS . . . . .	6-13
TABLE 6-3. COSTS OF CONTROL TECHNIQUES FOR MD NATURAL GAS-FIRED MODEL HEATERS . . . . .	6-15
TABLE 6-4. COSTS OF CONTROL TECHNIQUES FOR ND OIL-FIRED MODEL HEATERS . . . . .	6-17
TABLE 6-5. COSTS OF CONTROL TECHNIQUES FOR MD OIL-FIRED MODEL HEATERS . . . . .	6-19

LIST OF TABLES (continued)

	<u>Page</u>
TABLE 6-6. COSTS OF CONTROL TECHNIQUES FOR ND OLEFINS PYROLYSIS MODEL HEATERS . . . . .	6-20
TABLE 6-7. ND-TO-MD CONVERSION COSTS FOR THE ND MODEL HEATERS . . . . .	6-21
TABLE 6-8. COST EFFECTIVENESS OF CONTROL TECHNIQUES FOR ND NATURAL GAS-FIRED MODEL HEATERS . . . . .	6-23
TABLE 6-9. COST EFFECTIVENESS OF CONTROL TECHNIQUES FOR MD NATURAL GAS-FIRED MODEL HEATERS . . . . .	6-26
TABLE 6-10. COST EFFECTIVENESS OF CONTROL TECHNIQUES FOR ND OIL-FIRED MODEL HEATERS . . . . .	6-28
TABLE 6-11. COST EFFECTIVENESS OF CONTROL TECHNIQUES FOR MD OIL-FIRED MODEL HEATERS . . . . .	6-29
TABLE 6-12. COST EFFECTIVENESS OF CONTROL TECHNIQUES FOR ND PYROLYSIS MODEL HEATERS . . . . .	6-30
TABLE 6-13. CARB COST EFFECTIVENESS FOR NO <sub>x</sub> EMISSION CONTROL TECHNIQUES . . . . .	6-31
TABLE 6-14. RADIANT BURNER COST EFFECTIVENESS . . . . .	6-33
TABLE 7-1. OPTIMUM LOW-EXCESS-AIR, GASEOUS EMISSIONS AND EFFICIENCIES FOR SIX PROCESS HEATERS WITH LOW-NO <sub>x</sub> BURNERS . . . . .	7-6
TABLE 7-2. NITROGEN OXIDE AND CARBON MONOXIDE EMISSIONS FOR A 20 MMBtu/hr REFINERY HEATER WITH LNB PLUS LEA OPERATION (REFINERY FUEL GAS) . . . . .	7-8
TABLE 7-3. NITROGEN OXIDE AND CARBON MONOXIDE EMISSIONS FOR A 6.7 MMBtu/hr (200 hp) BOILER WITH LNB PLUS FGR . . . . .	7-9

## LIST OF FIGURES

	<u>Page</u>
Figure 2-1. Model heaters: NO <sub>x</sub> emission reductions, capital costs, and cost effectiveness at a capacity factor of 0.9 for ND, natural gas-fired, low- and medium-temperature heaters . . . . .	2-17
Figure 2-2. Model heaters: NO <sub>x</sub> emission reductions, capital costs, and cost effectiveness at a capacity factor of 0.9 for MD, natural gas-fired, low- and medium-temperature heaters . . . . .	2-18
Figure 2-3. Model heaters: NO <sub>x</sub> emission reductions, capital costs, and cost effectiveness at a capacity factor of 0.9 for ND, oil-fired, low- and medium-temperature heaters . . . . .	2-19
Figure 2-4. Model heaters: NO <sub>x</sub> emission reductions, capital costs, and cost effectiveness at a capacity factor of 0.9 for MD, oil-fired, low- and medium-temperature heaters . . . . .	2-20
Figure 2-5. Model heaters: NO <sub>x</sub> emission reductions, capital costs, and cost effectiveness at a capacity factor of 0.9 for ND olefins pyrolysis heaters . . . . .	2-21
Figure 3-1. Cross-section of a typical process heater . . . . .	3-4
Figure 3-2. Examples of radiant section tube orientations . . . . .	3-7
Figure 3-3. Typical burners by type of fuel burned . . . . .	3-9
Figure 3-4. Size distribution of the existing fired heater population . . . . .	3-11
Figure 3-5. Annual energy consumption projection for process heaters used in petroleum refining . . . . .	3-15
Figure 4-1. Impact of temperature on NO <sub>x</sub> formation . . . . .	4-3
Figure 4-2. Effect of fuel-bound nitrogen on NO <sub>x</sub> emissions . . . . .	4-5
Figure 4-3. Effect of combustion air preheat temperature on NO <sub>x</sub> emissions . . . . .	4-11

LIST OF FIGURES (continued)

	<u>Page</u>
Figure 4-4. Effect of firebox temperature on thermal NO <sub>x</sub> formation for gas-fired heaters with constant excess air . . . . .	4-13
Figure 4-5. Effect of excess air on NO <sub>x</sub> formation in gas-fired process heaters at various combustion air preheat temperatures . . . . .	4-16
Figure 4-6. Uncontrolled NO <sub>x</sub> emission data versus heat input for gas-fired refinery process heaters of various design types . . . . .	4-19
Figure 4-7. Uncontrolled NO <sub>x</sub> emission factors for gas-fired refinery process heaters with known burner configuration, draft type, and air preheat conditions . . . . .	4-20
Figure 4-8. Uncontrolled NO <sub>x</sub> emission rates for gas-fired process heaters at one refinery installation . . . . .	4-23
Figure 4-9. Natural draft process heater refinery inventory . . . . .	4-27
Figure 4-10. Mechanical draft process heater refinery inventory . . . . .	4-29
Figure 5-1. Effect of combustion air preheat temperature on NO <sub>x</sub> emissions . . . . .	5-5
Figure 5-2. Staged combustion air lances installed on a conventional gas burner . . . . .	5-7
Figure 5-3. Schematic of a staged-air low-NO <sub>x</sub> burner . . . . .	5-12
Figure 5-4. Schematic of a staged-fuel low-NO <sub>x</sub> burner . . . . .	5-16
Figure 5-5. Cross-section of an internal flue gas recirculation burner . . . . .	5-22
Figure 5-6. Exxon Thermal DeNO <sub>x</sub> <sup>®</sup> system . . . . .	5-28
Figure 5-7. Nalco Fuel Tech NO <sub>x</sub> OUT <sup>®</sup> -type NO <sub>x</sub> reduction system . . . . .	5-34
Figure 5-8. Schematic of a selective catalytic reduction system . . . . .	5-39



LIST OF FIGURES (continued)

	<u>Page</u>
Figure 5-9. Effect of temperature and oxygen on NO <sub>x</sub> conversion . . . . .	5-41
Figure 7-1. NO <sub>x</sub> emission factor for 10 process heaters equipped with low-NO <sub>x</sub> burners as a function of stack oxygen . . . . .	7-5
Figure 7-2. Pilot-scale test results, NH <sub>3</sub> emissions. Inlet NO = 700 ppm . . . . .	7-11
Figure 7-3. Pilot-scale test results; NO <sub>x</sub> reduction and N <sub>2</sub> O production versus temperature . . . . .	7-13

## 1.0 INTRODUCTION

Congress, in the Clean Air Act Amendments of 1990 (CAAA), amended Title I of the Clean Air Act (CAA) to address ozone nonattainment areas. A new Subpart 2 was added to Part D of Section 103. Section 183(c) of the new Subpart 2 provides that:

[w]ithin 3 years after the date of the enactment of the [CAAA], the Administrator shall issue technical documents which identify alternative controls for all categories of stationary sources of...oxides of nitrogen which emit, or have the potential to emit 25 tons per year or more of such air pollutant.

These documents are to be subsequently revised and updated as determined by the Administrator.

Process heaters have been identified as a category with emission sources that emit more than 25 tons of nitrogen oxide ( $\text{NO}_x$ ) per year. This alternative control techniques (ACT) document provides technical information for use by State and local agencies to develop and implement regulatory programs to control  $\text{NO}_x$  emissions from process heaters. Additional ACT documents are being developed for other stationary source categories.

The information in this ACT document was generated through literature searches and contacts with process heater control equipment vendors, engineering firms, chemical plants, and petroleum refineries. Chapter 2.0 presents a summary of the findings of this study. Chapter 3.0 presents information on process heater operation and industry applications. Chapter 4.0 contains a discussion of  $\text{NO}_x$  formation and uncontrolled process heater  $\text{NO}_x$  emission factors. Alternative control techniques and achievable controlled emission levels are included in

Chapter 5.0. The cost and cost effectiveness of each control technique are presented in Chapter 6.0 Chapter 7.0 describes environmental and energy impacts associated with implementing the NO<sub>x</sub> control techniques.

## 2.0 SUMMARY

This chapter presents a summary of the information contained in this document. Section 2.1 presents a summary of NO<sub>x</sub> formation and uncontrolled NO<sub>x</sub> emissions. Section 2.2 presents a summary of available NO<sub>x</sub> emission control techniques and achievable NO<sub>x</sub> emission reductions. Section 2.3 presents a summary of the capital costs and cost effectiveness for these NO<sub>x</sub> control techniques. Process heaters are direct fired heaters used primarily in the petroleum refining and petrochemical industries. Process fluids are heated to temperatures in excess of 204°C (400°F) in the radiative and convective sections of the heaters. Flue gas entering the convective section is usually in excess of 800°C (1500°F) for most process heaters.

Due to the broad spectrum of process heater designs and capacities, this study uses a limited number of model heaters to evaluate the available NO<sub>x</sub> control techniques for process heaters. The model heaters and uncontrolled emission factors are introduced in Chapter 4. The model heaters and uncontrolled emission factors are based on a refinery data base, published literature and data. The performance of the control techniques applied to model heaters is presented in Chapter 5 and is based on published literature and data. Costs and cost effectiveness of the control techniques applied to the model heaters are presented in Chapter 6 and are based on published cost methodologies.

### 2.1 UNCONTROLLED NO<sub>x</sub> EMISSIONS

Nitrogen oxides are produced by three different formation mechanisms: thermal, fuel, and prompt NO<sub>x</sub>. Thermal NO<sub>x</sub> is primarily temperature-dependent, and fuel NO<sub>x</sub> is primarily

dependent on the presence of fuel-bound nitrogen and the local oxygen concentration. Prompt  $\text{NO}_x$  is the least understood formation mechanism. Most combustion control techniques are designed to reduce thermal and/or fuel  $\text{NO}_x$ . Post combustion techniques reduce  $\text{NO}_x$  in the flue gas regardless of the formation mechanism.

Thermal  $\text{NO}_x$  formation increases rapidly at temperatures exceeding  $1540^\circ\text{C}$  ( $2800^\circ\text{F}$ ) and is the primary source of  $\text{NO}_x$  in natural gas- and refinery fuel gas-fired heaters. Refinery fuel gas firing generally yields higher thermal  $\text{NO}_x$  formation than natural gas firing due to the higher flame temperatures caused by the higher hydrogen content of the refinery fuel gas.

Fuel  $\text{NO}_x$  formation is minimal in heaters that fire natural gas and refinery fuel gas, which contain little or no fuel-bound nitrogen. Fuel  $\text{NO}_x$  represents a considerable fraction of the total  $\text{NO}_x$  emissions in heaters burning nitrogen-bearing fuels, such as distillate and residual oils.

Uncontrolled emission factors for the model heaters are presented in Table 2-1. The uncontrolled  $\text{NO}_x$  emission factors for natural gas-fired, low- and medium-temperature model heaters are 0.098 and 0.197 pounds per million British thermal units (lb/MMBtu) for the natural draft (ND) and mechanical draft (MD) heaters, respectively. The uncontrolled  $\text{NO}_x$  emission factors for the ND oil-fired model heaters are 0.200 and 0.420 lb/MMBtu for distillate and residual oil-firing, respectively. The distillate and residual oil-fired MD model heaters have uncontrolled  $\text{NO}_x$  emission factors of 0.320 and 0.540, respectively. The uncontrolled emission factors for the pyrolysis model heaters are 0.135 and 0.162 lb/MMBtu for the natural gas-fired and high-hydrogen fuel gas-fired heaters, respectively.

The uncontrolled emission factors for MD model heaters are greater than for ND model heaters because the MD model heaters have combustion air preheat, which increases thermal  $\text{NO}_x$  emissions. The oil-fired model heaters have higher thermal  $\text{NO}_x$  emissions than the natural gas-fired model heaters, primarily due to the higher flame temperature for oil firing. Residual oil

TABLE 2-1. UNCONTROLLED EMISSION FACTORS FOR MODEL HEATERS

Model heater type	Uncontrolled emission factor, lb/MMBtu		
	Thermal NO <sub>x</sub>	Fuel NO <sub>x</sub>	Total NO <sub>x</sub> <sup>a</sup>
ND, natural gas-fired <sup>b</sup>	0.098	N/A	0.098
MD, natural gas-fired <sup>b</sup>	0.197	N/A	0.197
ND, distillate oil-fired	0.140	0.060	0.200
ND, residual oil-fired	0.140	0.280	0.420
MD, distillate oil-fired	0.260	0.060	0.320
MD, residual oil-fired	0.260	0.280	0.540
ND, pyrolysis, natural gas-fired	0.135	N/A	0.104
ND, pyrolysis, high-hydrogen fuel gas-fired <sup>c</sup>	0.162 <sup>d</sup>	N/A	0.140

<sup>a</sup>Total NO<sub>x</sub> = Thermal NO<sub>x</sub> + Fuel NO<sub>x</sub>

<sup>b</sup>Heaters firing refinery fuel gas with up to 50 mole percent hydrogen can have up to 20 percent higher NO<sub>x</sub> emissions than similar heaters firing natural gas.

<sup>c</sup>High-hydrogen fuel gas is fuel gas with 50 mole percent or greater hydrogen content.

<sup>d</sup>Calculated assuming approximately 50 mole percent hydrogen.

N/A = Not applicable.

contains a greater content of fuel-bound nitrogen and therefore has higher fuel NO<sub>x</sub> emissions than the distillate oil-fired heaters.

## 2.2 AVAILABLE NO<sub>x</sub> EMISSION CONTROL TECHNIQUES

The following NO<sub>x</sub> control techniques are currently used in industry: low-NO<sub>x</sub> burners (LNB's), ultra-low NO<sub>x</sub> burners (ULNB's), selective noncatalytic reduction (SNCR), and selective catalytic reduction (SCR). Also, LNB's are used in combination with flue gas recirculation (FGR), SNCR, and SCR.

Combustion modifications such as LNB, ULNB and FGR inhibit NO<sub>x</sub> formation by controlling the combustion process. Staging techniques are usually used by LNB and ULNB to supply excess air to cool the combustion process or to reduce available oxygen in the flame zone. Staged-air LNB's create a fuel-rich reducing primary combustion zone and a fuel-lean secondary combustion zone. Staged-fuel LNB's create a lean primary combustion zone that is relatively cool due to the presence of excess air, which acts as a heat sink to lower combustion temperatures. The secondary combustion zone is fuel-rich. Ultra-low-NO<sub>x</sub> burners use staging techniques similar to staged-fuel LNB in addition to internal flue gas recirculation. Flue gas recirculation returns a portion of the flue gas to the combustion zone through ducting external to the firebox that reduces flame temperature and dilutes the combustion air supply with relatively inert flue gas.

Unlike combustion controls, SNCR and SCR do not reduce NO<sub>x</sub> by inhibiting NO<sub>x</sub> formation, but reduce NO<sub>x</sub> in the flue gas. These techniques control NO<sub>x</sub> by using a reactant that reduces NO<sub>x</sub> to nitrogen (N<sub>2</sub>) and water. The reactant, ammonia (NH<sub>3</sub>) or urea for SNCR, and NH<sub>3</sub> for SCR, is injected into the flue gas stream. Temperature and residence time are the primary factors that influence the reduction reaction. Selective catalytic reduction uses a catalyst to facilitate the reaction.

The reduction efficiency of each control technique varies depending on the process heater application and design. The efficiencies for LNB, ULNB, and SCR are considered to be representative averages based on operating experience. Fuel NO<sub>x</sub>

reduction efficiencies and the reduction efficiencies for FGR, and SNCR are based on a Canadian Petroleum Products Institute report. Tables 2-2 and 2-3 present the reduction efficiencies for each NO<sub>x</sub> control technique. The total effective reduction efficiencies for natural gas- and refinery fuel gas-fired heaters are shown in Table 2-2 and for low- and medium-temperature process heaters range from 50 percent for LNB to 88 percent for LNB plus SCR. The total effective percent reductions for pyrolysis furnaces are lower for control techniques that use LNB's or ULNB's compared to the low- and medium-temperature heaters, and range from 25 percent for LNB to 81 percent for LNB plus SCR. The total effective reduction efficiencies of the oil-fired heaters are shown in Table 2-3 and range from 27 percent for ND LNB on ND residual oil-fired heaters to 92 percent for MD LNB plus SCR on MD distillate oil-fired heaters. The total effective reduction efficiencies of the gas-fired heaters are the same for ND or MD operation. However, different reduction efficiencies for thermal and fuel NO<sub>x</sub> emissions result in varying total effective reduction efficiencies for the oil-fired heaters.

### 2.3 CAPITAL COSTS AND COST EFFECTIVENESS

The capital costs and cost effectiveness for each of the NO<sub>x</sub> control techniques discussed in Section 2.2 are presented in this section for the model heaters. Cost methodologies from reports published by the Canadian Petroleum Products Institute and the South Coast Air Quality Management District are used to estimate the capital and annual costs for the control techniques.

The cost of converting ND heaters to MD heaters is included in the cost analysis in which MD control techniques are used on ND model heaters. Natural draft-to-MD conversion is not considered a NO<sub>x</sub> control technique and is usually performed to take advantage of thermal efficiency gains. These efficiency gains are site specific and are not included or quantified in this study. Therefore, the actual cost effectiveness of control



TABLE 2-2. REDUCTION EFFICIENCIES FOR CONTROL TECHNIQUES APPLIED TO NATURAL GAS- AND REFINERY FUEL GAS-FIRED PROCESS HEATERS AND PYROLYSIS FURNACES

Control technique - low and medium temperature heaters	Total effective NO <sub>x</sub> reduction, <sup>a</sup> percent
LNB	50
ULNB	75
SNCR	60
SCR	75
LNB + FGR	55
LNB + SNCR	80
LNB + SCR	88

Control technique - pyrolysis furnaces	Total effective NO <sub>x</sub> reduction, <sup>a</sup> percent
LNB	25
ULNB	50
SNCR	60
SCR	75
LNB + FGR	55
LNB + SNCR	70
LNB + SCR	81

<sup>a</sup>Further discussion on the NO<sub>x</sub> reduction efficiencies of each control technique is included in Chapter 5.

TABLE 2-3. REDUCTION EFFICIENCIES FOR CONTROL TECHNIQUES APPLIED TO ND AND MD, DISTILLATE AND RESIDUAL OIL-FIRED PROCESS HEATERS

Draft and fuel type	Control technique	Total effective NO <sub>x</sub> reduction, <sup>a</sup> percent
ND, distillate	(ND) LNB	40
	(MD) LNB	43
	(ND) ULNB	76
	(MD) ULNB	74
	SNCR <sup>b</sup>	60
	(MD) SCR	75
	(MD) LNB + FGR	43
	(ND) LNB + SNCR	76
	(MD) LNB + SNCR	77
	(MD) LNB + SCR	86
	ND, residual	(ND) LNB
(MD) LNB		33
(ND) ULNB		77
(MD) ULNB		73
SNCR		60
(MD) SCR		75
(MD) LNB + FGR		28
(ND) LNB + SNCR		71
(MD) LNB + SNCR		73
(MD) LNB + SCR		83
MD, distillate		(MD) LNB
	(MD) ULNB	74
	(MD) SNCR	60
	(MD) SCR	75
	(MD) LNB + FGR	48
	(MD) LNB + SNCR	78
	(MD) LNB + SCR	92
MD, residual	(MD) LNB	37
	(MD) ULNB	73
	(MD) SNCR	60
	(MD) SCR	75
	(MD) LNB + FGR	34
	(MD) LNB + SNCR	75
	(MD) LNB + SCR	91

<sup>a</sup>Further discussion on the NO<sub>x</sub> reduction efficiencies of each control technique is included in Chapter 5.

<sup>b</sup>Reduction efficiencies for ND or MD SNCR are equal

techniques that include ND-to-MD conversion may be lower than shown in this study.

Cost effectiveness of the control techniques, in \$/ton of NO<sub>x</sub> removed, is calculated as the total annual cost divided by the annual NO<sub>x</sub> reduction, in tons, for each control technique applied to each model heater. Tables 2-4 through 2-8 present the cost effectiveness of these control techniques for the ND natural gas-fired, MD natural gas-fired, ND oil-fired, MD oil-fired, and ND pyrolysis model heaters, respectively. Burner control techniques generally have the lowest cost effectiveness, with SCR having the highest. Ultra-low-NO<sub>x</sub> burner cost effectiveness is lower than LNB in all cases because the additional reduction efficiency more than offsets the additional cost. The cost effectiveness of SNCR is greater than that of LNB in most cases because of the higher capital and operating costs for SNCR. Low-NO<sub>x</sub> burners plus FGR have higher cost effectiveness than SNCR in most cases. The capital cost for SNCR are comparable to LNB plus FGR, but the higher operating costs result in higher cost-effectiveness values for SNCR. The highest reduction efficiencies are achieved by SCR and LNB plus SCR, but these techniques also have the highest cost effectiveness due to the relatively high capital and annual costs for SCR.

The lowest cost effectiveness is achieved with ULNB's and the highest with SCR for each model heater. The range of cost effectiveness for each of the five types of model heaters at a capacity factor of 0.9 are (1) \$981/ton to \$16,200/ton for the ND natural gas-fired heaters, (2) \$813/ton to \$10,600/ton for the MD natural gas-fired heaters, (3) \$419/ton to \$6,490/ton for the ND oil-fired heaters, (4) \$245/ton to \$4,160/ton for the MD oil-fired heaters, and (5) \$1,790/ton to \$14,100/ton for the ND pyrolysis heaters. Figures 2-1 through 2-5 graphically present the reduction efficiencies, capital cost, and cost effectiveness for the model heaters.

TABLE 2-4. MODEL HEATERS: NO<sub>x</sub> EMISSION REDUCTIONS, CAPITAL COSTS, AND COST EFFECTIVENESS FOR ND, NATURAL GAS-FIRED LOW- AND MEDIUM-TEMPERATURE HEATERS

Model heater capacity, MMBtu/hr	Uncontrolled NO <sub>x</sub> emission factor, lb/MMBtu	NO <sub>x</sub> control technique	Total effective NO <sub>x</sub> reduction, percent	NO <sub>x</sub> reduction, tons/yr <sup>a,b</sup>	Capital cost, \$	Cost effectiveness, \$/ton @ capacity factors: <sup>c</sup>			
						0.1	0.5	0.9	
17	0.098	(ND) LNB	50	3.65	58,200	25,400	5,070	2,820	
	0.197	(MD) LNB	50	7.33	191,000	41,400	8,280	4,600	
	0.098	(ND) ULNB	75	5.47	62,500	18,200	3,630	2,020	
	0.197	(MD) ULNB	75	1.10	249,000	36,000	7,200	4,000	
	0.098	(ND) SNCR	60	4.38	155,000	56,700	11,800	6,770	
	0.197	(MD) SNCR	60	8.80	258,000	47,100	9,760	5,610	
	0.197	(MD) SCR	75	1.10	951,000	141,000	28,700	16,200	
	0.197	(MD) LNB + FGR	55	8.07	253,000	50,000	10,100	5,710	
	0.098	(ND) LNB + SNCR	80	5.84	213,000	58,400	12,000	6,840	
	0.197	(MD) LNB + SNCR	80	1.17	346,000	47,100	9,690	5,530	
	0.197	(MD) LNB + SCR	88	12.8	995,000	132,000	26,700	15,100	
	36	0.098	(ND) LNB	50	7.73	92,600	19,100	3,810	2,120
		0.197	(MD) LNB	50	15.5	302,000	30,900	6,170	3,430
		0.098	(ND) ULNB	75	11.6	96,900	13,300	2,660	1,480
0.197		(MD) ULNB	75	23.3	308,000	21,000	4,200	2,330	
0.098		(ND) SNCR	60	9.27	243,000	42,100	8,850	5,150	
0.197		(MD) SNCR	60	18.6	405,000	35,000	7,260	4,180	
0.197		(MD) SCR	75	23.3	1,500,000	106,000	21,700	12,300	
0.197		(MD) LNB + FGR	55	17.1	399,000	37,300	7,590	4,290	
0.098		(ND) LNB + SNCR	80	12.4	335,000	43,500	9,020	5,190	
0.197		(MD) LNB + SNCR	80	24.9	544,000	35,100	7,280	4,190	
0.197		(MD) LNB + SCR	88	27.2	1,570,000	99,200	20,200	11,400	

TABLE 2-4. (continued)

Model heater capacity, MMBtu/hr	Uncontrolled NO <sub>x</sub> emission factor, lb/MMBtu	NO <sub>x</sub> control technique	Total effective NO <sub>x</sub> reduction, percent	NO <sub>x</sub> reduction, tons/yr <sup>a,b</sup>	Capital cost, \$	Cost effectiveness, \$/ton @ capacity factors: <sup>c</sup>			
						0.1	0.5	0.9	
77	0.098	(ND) LNB	50	16.5	133,000	12,800	2,570	1,430	
	0.197	(MD) LNB	50	33.2	457,000	21,900	4,370	2,430	
	0.098	(ND) ULNB	75	24.8	138,000	8,830	1,770	981	
	0.197	(MD) ULNB	75	49.8	463,000	14,800	2,950	1,640	
	0.098	(ND) SNCR	60	19.8	383,000	31,200	6,670	3,940	
	0.197	(MD) SNCR	60	39.9	639,000	25,900	5,450	3,170	
	0.197	(MD) SCR	75	49.8	2,390,000	80,100	16,400	9,370	
	0.197	(MD) LNB + FGR	55	36.5	610,000	26,700	5,480	3,120	
	0.098	(ND) LNB + SNCR	80	26.4	516,000	31,400	6,610	3,850	
	0.197	(MD) LNB + SNCR	80	53.2	839,000	25,400	5,340	3,119	
	0.197	(MD) LNB + SCR	88	58.1	2,480,000	74,100	15,200	8,640	
	121	0.098	(ND) LNB	50	26.0	232,000	14,200	2,840	1,580
		0.197	(MD) LNB	50	52.2	685,000	20,900	4,170	2,320
		0.098	(ND) ULNB	75	39.0	237,000	9,660	1,930	1,070
0.197		(MD) ULNB	75	78.3	691,000	14,000	2,810	1,560	
0.098		(ND) SNCR	60	31.2	502,000	26,100	5,660	3,380	
0.197		(MD) SNCR	60	62.6	838,000	21,700	4,610	2,710	
0.197		(MD) SCR	75	78.3	3,160,000	67,900	14,000	8,020	
0.197		(MD) LNB + FGR	55	57.4	887,000	24,700	5,080	2,890	
0.098		(ND) LNB + SNCR	80	41.6	734,000	28,500	6,020	3,520	
0.197		(MD) LNB + SNCR	80	83.5	1,190,000	22,900	4,840	2,830	
0.197		(MD) LNB + SCR	88	91.4	3,370,000	64,300	13,200	7,550	

TABLE 2-4. (continued)

Model heater capacity, MMBtu/hr	Uncontrolled NO <sub>x</sub> emission factor, lb/MMBtu	NO <sub>x</sub> control technique	Total effective NO <sub>x</sub> reduction, percent	NO <sub>x</sub> reduction, tons/yr <sup>a,b</sup>	Capital cost, \$	Cost effectiveness, \$/ton @ capacity factors: <sup>c</sup>		
						0.1	0.5	0.9
186	0.098	(ND) LNB	50	39.9	346,000	13,800	2,760	1,530
	0.197	(MD) LNB	50	80.2	955,000	18,900	3,780	2,100
	0.098	(ND) ULNB	75	59.9	351,000	9,310	1,860	1,030
	0.197	(MD) ULNB	75	12.0	961,000	12,700	2,540	1,410
	0.098	(ND) SNCR	60	47.9	650,000	22,100	4,850	2,930
	0.197	(MD) SNCR	60	96.3	1,090,000	18,300	3,930	2,330
	0.197	(MD) SCR	75	120	4,130,000	58,200	12,100	6,940
	0.197	(MD) LNB + FGR	55	88.3	1,220,000	22,100	4,550	2,600
	0.098	(ND) LNB + SNCR	80	63.9	996,000	25,200	5,360	3,150
	0.197	(MD) LNB + SNCR	80	128	1,600,000	20,200	4,300	2,530
	0.197	(MD) LNB + SCR	88	140	4,460,000	55,700	11,500	6,600

<sup>a</sup>NO<sub>x</sub> reductions = Uncontrolled emission factor (lb/MMBtu) \* Capacity(MMBtu/hr) \* Effective reduction (%) \* 1 ton/2,000lb \* 8,760 hr/yr \* Capacity factor.  
<sup>b</sup>NO<sub>x</sub> reductions in this column are calculated at a capacity factors of 1.0. To obtain reductions corresponding to particular capacity factors, substitute the desired capacity factor into the above equation.

<sup>c</sup>Cost effectiveness is calculated by dividing the total annual cost (TAC) by the NO<sub>x</sub> reductions. Refer to Chapter 6 for the TAC.

TABLE 2-5. MODEL HEATERS: NO<sub>x</sub> EMISSION REDUCTIONS, CAPITAL COSTS, AND COST EFFECTIVENESS FOR MD, NATURAL GAS-FIRED, LOW- AND MEDIUM-TEMPERATURE HEATERS

Model heater capacity, MMBtu/hr	Uncontrolled NO <sub>x</sub> emission factor, lb/MMBtu	NO <sub>x</sub> control technique	Total effective NO <sub>x</sub> reduction, percent	NO <sub>x</sub> reduction, tons/yr <sup>a,b</sup>	Capital cost, \$	Cost effectiveness, \$/ton @ capacity factors: <sup>c</sup>		
						0.1	0.5	0.9
40	0.197	LNB	50	17.3	130,000	12,000	2,390	1,330
		ULNB	75	25.9	136,000	8,380	1,680	931
		SNCR	60	20.7	258,000	20,300	4,400	2,640
		SCR	75	25.9	1,270,000	91,500	18,700	10,600
		LNB + FGR	55	19.0	234,000	19,700	4,080	2,340
		LNB + SNCR	80	27.6	388,000	22,700	4,790	2,810
		LNB + SCR	88	30.2	1,400,000	85,200	17,400	9,880
77	0.197	LNB	50	33.2	282,000	13,500	2,700	1,500
		ULNB	75	49.8	288,000	9,200	1,840	1,020
		SNCR	60	39.9	383,000	15,700	3,480	2,130
		SCR	75	49.8	1,900,000	71,900	14,800	8,460
		LNB + FGR	55	36.5	436,000	19,100	3,960	2,270
		LNB + SNCR	80	53.2	665,000	20,200	4,300	2,530
		LNB + SCR	88	58.1	2,180,000	69,300	14,200	8,110
114	0.197	LNB	50	49.2	507,000	16,400	3,280	1,820
		ULNB	75	73.8	514,000	11,100	2,210	1,230
		SNCR	60	59.0	484,000	13,500	3,040	1,880
		SCR	75	73.8	2,420,000	62,800	12,900	7,410
		LNB + FGR	55	54.1	702,000	20,800	4,290	2,460
		LNB + SNCR	80	78.7	992,000	20,400	4,330	2,550
		LNB + SCR	88	86.1	2,930,000	62,800	12,900	7,390

TABLE 2-5. (continued)

Model heater capacity, MMBtu/hr	Uncontrolled NO <sub>x</sub> emission factor, lb/MMBtu	NO <sub>x</sub> control technique	Total effective NO <sub>x</sub> reduction, percent	NO <sub>x</sub> reduction, tons/yr <sup>a,b</sup>	Capital cost, \$	Cost effectiveness, \$/ton @ capacity factors: <sup>c</sup>		
						0.1	0.5	0.9
174	0.197	LNB	50	75.1	541,000	11,500	2,290	1,270
		ULNB	75	113	548,000	7,730	1,550	859
		SNCR	60	90.1	624,000	11,400	2,630	1,660
		SCR	75	113	3,150,000	53,700	11,200	6,440
		LNB + FGR	55	82.6	792,000	15,400	3,220	1,860
		LNB + SNCR	80	120	1,170,000	15,700	3,410	2,040
263	0.197	LNB + SCR	88	131	3,700,000	52,600	10,900	6,250
		LNB	50	113	777,000	10,900	2,180	1,210
		ULNB	75	170	783,000	7,310	1,460	813
		SNCR	60	136	800,000	9,770	2,300	1,470
		SCR	75	170	4,090,000	46,500	9,730	5,640
		LNB + FGR	55	125	1,100,000	14,200	2,960	1,720
LNB + SNCR	80	182	15,700	1,580,000	14,100	3,080	1,860	
								LNB + SCR

<sup>a</sup>NO<sub>x</sub> reductions = Uncontrolled emission factor (lb/MMBtu) \* Capacity(MMBtu/hr) \* Effective reduction (%) \* 1 ton/2,000lb \* 8,760 hr/yr \* Capacity factor.

<sup>b</sup>NO<sub>x</sub> reductions in this column are calculated at a capacity factors of 1.0. To obtain reductions corresponding to particular capacity factors, substitute the desired capacity factor into the above equation.

<sup>c</sup>Cost effectiveness is calculated by dividing the total annual cost (TAC) by the NO<sub>x</sub> reductions. Refer to Chapter 6 for the TAC.



TABLE 2-6. MODEL HEATERS: NO<sub>x</sub> EMISSION REDUCTIONS, CAPITAL COSTS, AND COST EFFECTIVENESS FOR ND, OIL-FIRED, LOW- AND MEDIUM-TEMPERATURE HEATERS

Model heater capacity, M MBtu/hr	Fuel	Uncontrolled NO <sub>x</sub> emission factor, lb/MMBtu		NO <sub>x</sub> control technique	Total effective NO <sub>x</sub> reduction, percent	NO <sub>x</sub> reduc. ton/yr. <sup>b</sup>	Capital cost, \$	Cost effectiveness, @ capacity factors: <sup>c</sup>					
		Thermal NO <sub>x</sub>	Fuel NO <sub>x</sub>					0.1	0.5	0.9			
69	Distillate oil	0.14	0.06	(ND) LNB	40	23.9	227,000	15,100	3,030	1,680			
		0.26		(MD) LNB	45	43.8	581,000	21,100	4,220	2,340			
		0.14		(ND) ULNB	76	45.9	232,000	8,030	1,610	892			
		0.26		(MD) ULNB	74	72.0	588,000	13,000	2,600	1,440			
		0.14		(ND) SNCR	60	36.3	358,000	16,300	3,750	2,350			
		0.26		(MD) SNCR	60	58.0	598,000	16,900	3,780	2,330			
		0.26		(MD) SCR	75	72.5	2,240,000	51,800	11,000	6,480			
		0.26		(MD) LNB + FGR	48	45.9	558,000	25,200	5,140	2,910			
		0.14		(ND) LNB + SNCR	76	45.8	586,000	20,800	4,540	2,740			
		0.26		(MD) LNB + SNCR	78	75.6	939,000	20,200	4,340	2,580			
		0.26		(MD) LNB + SCR	86	83.5	2,480,000	51,500	10,900	6,360			
		69		Residual oil	0.14	0.28	(ND) LNB	27	33.8	227,000	10,700	2,140	1,190
					0.26		(MD) LNB	37	60.4	581,000	15,300	3,06	1,700
					0.14		(ND) ULNB	77	97.7	232,000	3,770	763	419
0.26	(MD) ULNB		73		120		588,000	7,790	1,560	866			
0.14	(ND) SNCR		60		76.2		358,000	7,880	1,800	1,230			
0.26	(MD) SNCR		60		97.9		598,000	10,100	2,280	1,420			
0.26	(MD) SCR		75		122		2,240,000	30,600	6,400	3,710			
0.26	(MD) LNB + FGR		34		55.9		558,000	20,700	4,220	2,390			
0.14	(ND) LNB + SNCR		71		89.7		586,000	10,700	2,360	1,430			
0.26	(MD) LNB + NCR		75		122		939,000	12,500	2,740	1,650			
0.26	(MD) LNB + SCR		84		138		2,480,000	31,200	6,480	3,740			

<sup>a</sup>NO<sub>x</sub> reductions = Uncontrolled emission factor (lb/MMBtu) \* Capacity (MMBtu/hr) \* Effective reduction (%) \* 1 ton/2,000lb \* 8,760 hr/yr \* Capacity factor.  
<sup>b</sup>NO<sub>x</sub> reductions in this column are calculated at a capacity factors of 1.0. To obtain reductions corresponding to particular capacity factors, substitute the desired capacity factor into the above equation.  
<sup>c</sup>Cost effectiveness is calculated by dividing the total annual cost (TAC) by the NO<sub>x</sub> reductions. Refer to Chapter 6 for the TAC.

TABLE 2-7. MODEL HEATERS: NO<sub>x</sub> EMISSION REDUCTIONS, CAPITAL COSTS, AND COST EFFECTIVENESS FOR MD, OIL-FIRED, LOW- AND MEDIUM-TEMPERATURE HEATERS

Model heater capacity, MMBtu/hr	Fuel	Uncontrolled NO <sub>x</sub> emission factor, lb/MMBtu		NO <sub>x</sub> control technique	Total effective NO <sub>x</sub> reduction, percent	NO <sub>x</sub> reduction, ton/yr <sup>a,b</sup>	Capital cost, \$	Cost effectiveness, \$/ton capacity factors: <sup>c</sup>		
		Thermal NO <sub>x</sub>	Fuel NO <sub>x</sub>					0.1	0.5	0.9
135	Distillate oil	0.26	0.06	LNB	45	85.7	319,000	5,920	1,180	658
				ULNB	74	141	326,000	3,680	735	408
				SNCR	60	114	536,000	8,010	2,000	1,340
				SCR	75	142	2,780,000	35,300	7,280	4,160
				LNB + FGR	48	89.9	535,000	9,570	2,010	1,170
				LNB + SNCR	78	148	855,000	9,580	2,230	1,410
				LNB + SCR	92	174	3,010,000	30,800	6,340	3,620
135	Residual oil	0.26	0.28	LNB	37	118	319,000	4,290	858	477
				ULNB	73	235	326,000	2,210	442	245
				SNCR	60	192	536,000	4,830	1,280	880
				SCR	75	239	2,780,000	20,900	4,330	2,480
				LNB + FGR	34	109	535,000	7,870	1,650	961
				LNB + SNCR	75	239	855,000	6,000	1,450	942
				LNB + SCR	91	289	3,010,000	18,500	3,820	3,190

<sup>a</sup>NO<sub>x</sub> reductions = Uncontrolled emission factor (lb/MMBtu) \* Capacity(MMBtu/hr) \* Effective reduction (%) \* 1 ton/2,000lb \* 8,760 hr/yr \* capacity factor.

<sup>b</sup>NO<sub>x</sub> reductions in this column are calculated at a capacity factors of 1.0. To obtain reductions corresponding to particular capacity factors, substitute the desired capacity factor into the above equation.

<sup>c</sup>Cost effectiveness is calculated by dividing the total annual cost (TAC) by the NO<sub>x</sub> reductions. Refer to Chapter 6 for the TAC.

TABLE 2-8. MODEL HEATERS: NO<sub>x</sub> EMISSION REDUCTIONS, CAPITAL COSTS, AND COST EFFECTIVENESS FOR ND OLEFINS PYROLYSIS HEATERS

Model heater capacity, MMBtu/hr	Fuel	Uncontrolled NO <sub>x</sub> emission factor, lb/MMBtu	NO <sub>x</sub> control technique	Total effective NO <sub>x</sub> reduction, percent	Reduction, ton/yr <sup>a,b</sup>	Capital cost, \$	Cost effectiveness, \$/ton @ capacity factors: <sup>c</sup>		
							0.1	0.5	0.9
84	natural gas	0.135	(ND) LNB	25	37.2	248,000	31,700	6,350	3,530
			(MD) LNB	25	37.2	642,000	82,200	16,400	9,130
			(ND) ULNB	50	24.9	252,000	16,100	3,230	1,790
			(MD) ULNB	50	24.9	648,000	41,500	8,300	4,610
			(ND) SNCR	60	19.9	403,000	22,000	4,780	2,870
			(MD) SNCR	60	19.9	673,000	36,400	7,660	4,470
			SCR	75	12.4	2,520,000	113,000	23,400	13,500
			LNB + FGR	55	22.3	804,000	47,000	9,600	5,440
			(ND) LNB + SNCR	70	14.9	651,000	30,200	6,360	3,720
			(MD) LNB + SNCR	70	14.9	1,050,000	48,200	9,970	5,720
			LNB + SCR	81	9.3	2,900,000	119,000	24,600	14,100
84	high-hydrogen fuel gas	0.162	(ND) LNB	25	44.7	248,000	26,400	5,290	2,940
			(MD) LNB	25	44.7	642,000	68,500	13,700	7,610
			(ND) ULNB	50	29.8	252,000	13,400	2,690	1,490
			(MD) ULNB	50	29.8	648,000	34,600	6,920	3,840
			(ND) SNCR	60	23.9	403,000	18,400	4,040	2,450
			(MD) SCNR	60	23.9	673,000	30,400	6,440	3,780
			SCR	75	14.9	2,520,000	94,300	19,600	11,300
			LNB + FGR	55	26.8	804,000	39,200	8,000	4,530
			(ND) LNB + SNCR	70	17.9	651,000	25,200	5,350	3,140
			(MD) LNB + SNCR	70	17.9	1,050,000	40,200	8,350	4,810
			LNB + SCR	81	11.2	2,900,000	99,500	20,600	11,800

<sup>a</sup>NO<sub>x</sub> reductions = Uncontrolled emission factor (lb/MMBtu) \* Capacity(MMBtu/hr) \* effective reduction (%) \* 1 ton/2,000 lb \* 8,760 hr/yr \* Capacity factor.

<sup>b</sup>NO<sub>x</sub> reductions in this column are calculated at a capacity factor of 1.0. To obtain reductions corresponding to other capacity factors, substitute the desired capacity factor into the above equation.

<sup>c</sup>Cost effectiveness is calculated by dividing the total annual cost (TAC) by the NO<sub>x</sub> reductions. Refer to Chapter 6 for the TAC.

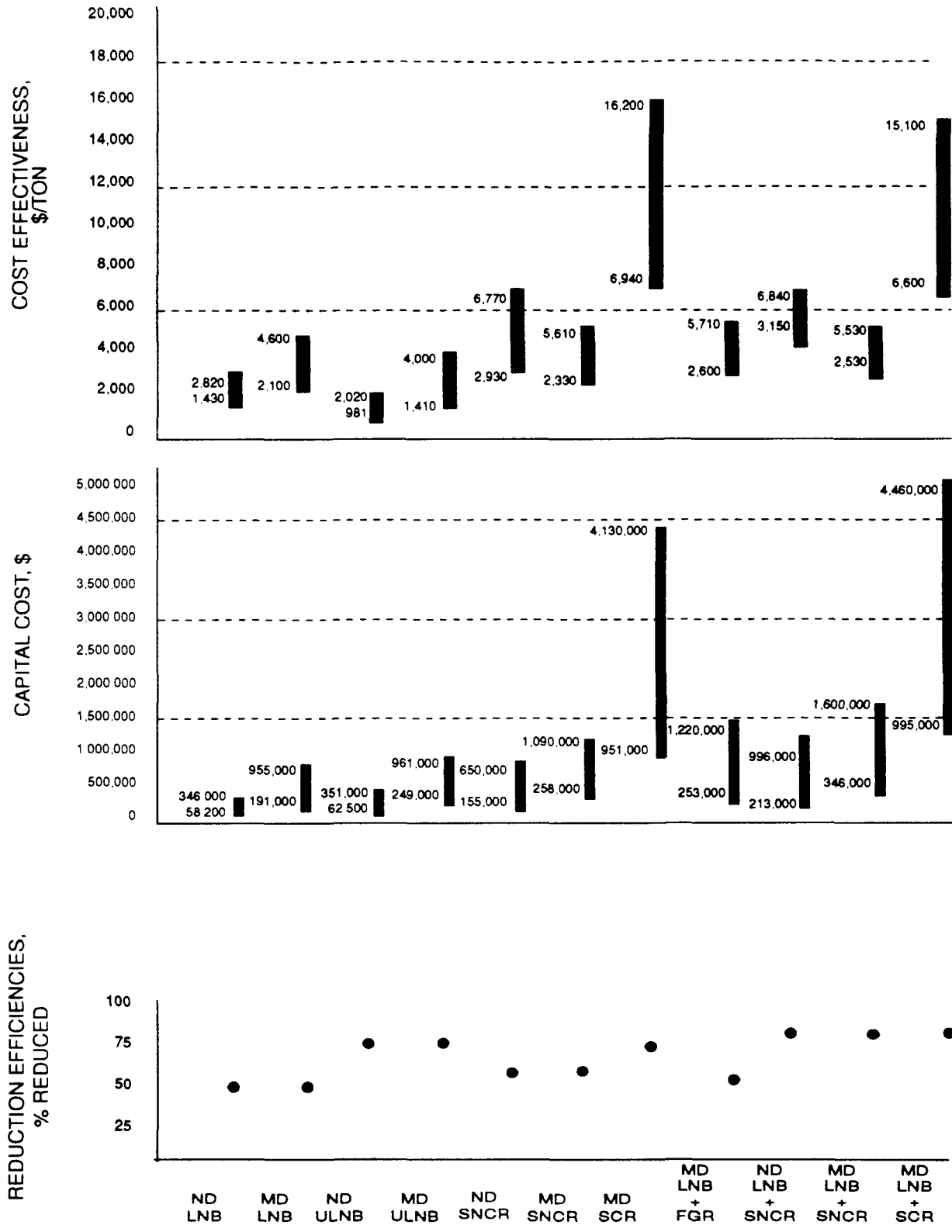

Figure 2-1. Model heaters: NO<sub>x</sub> emission reductions, capital costs, and cost effectiveness at a capacity factor of 0.9 for ND, natural gas-fired, low- and medium-temperature heaters.

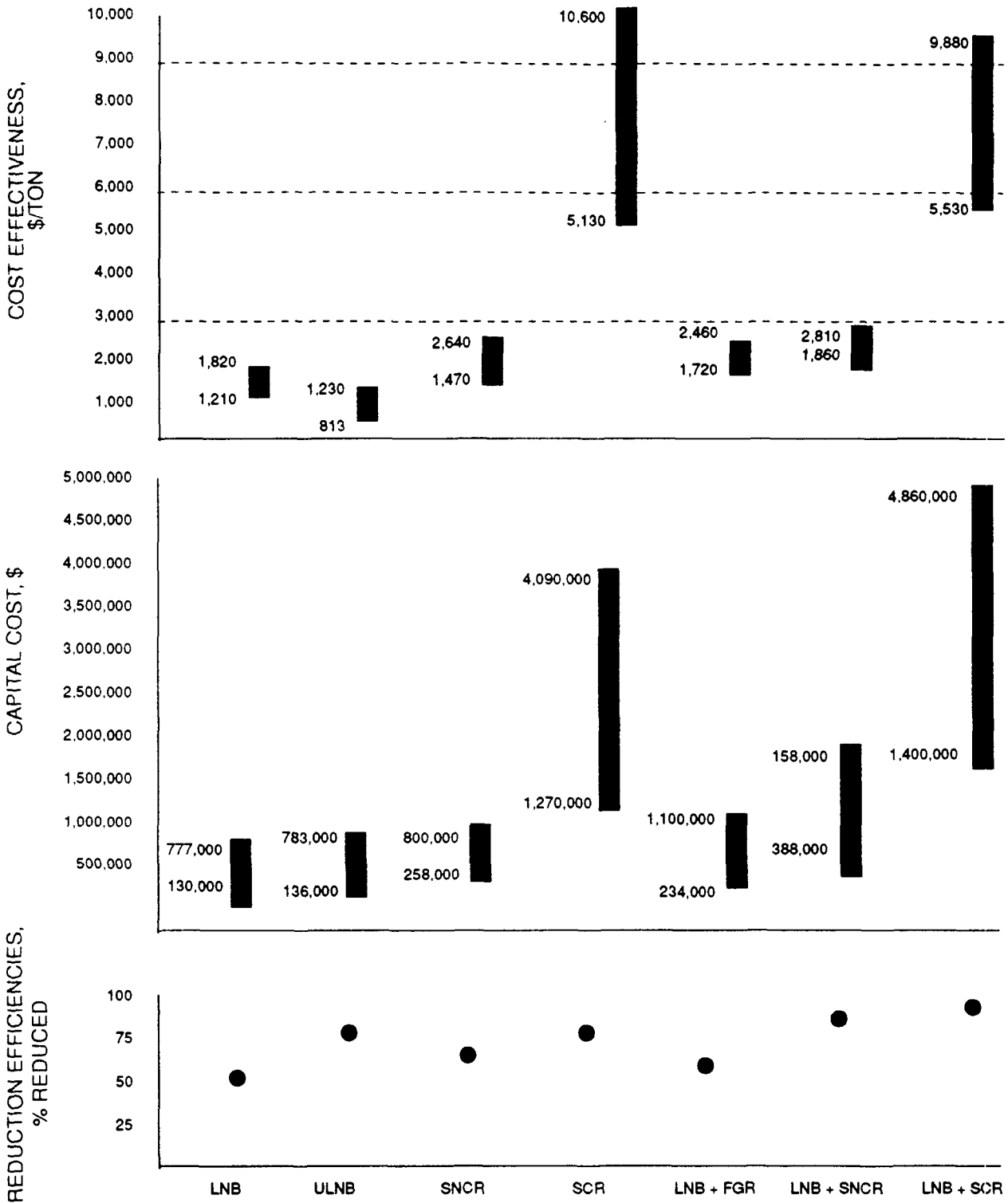

Figure 2-2. Model heaters: NO<sub>x</sub> emission reductions, capital costs, and cost effectiveness at a capacity factor of 0.9 for MD, natural gas-fired, low- and medium-temperature heaters.

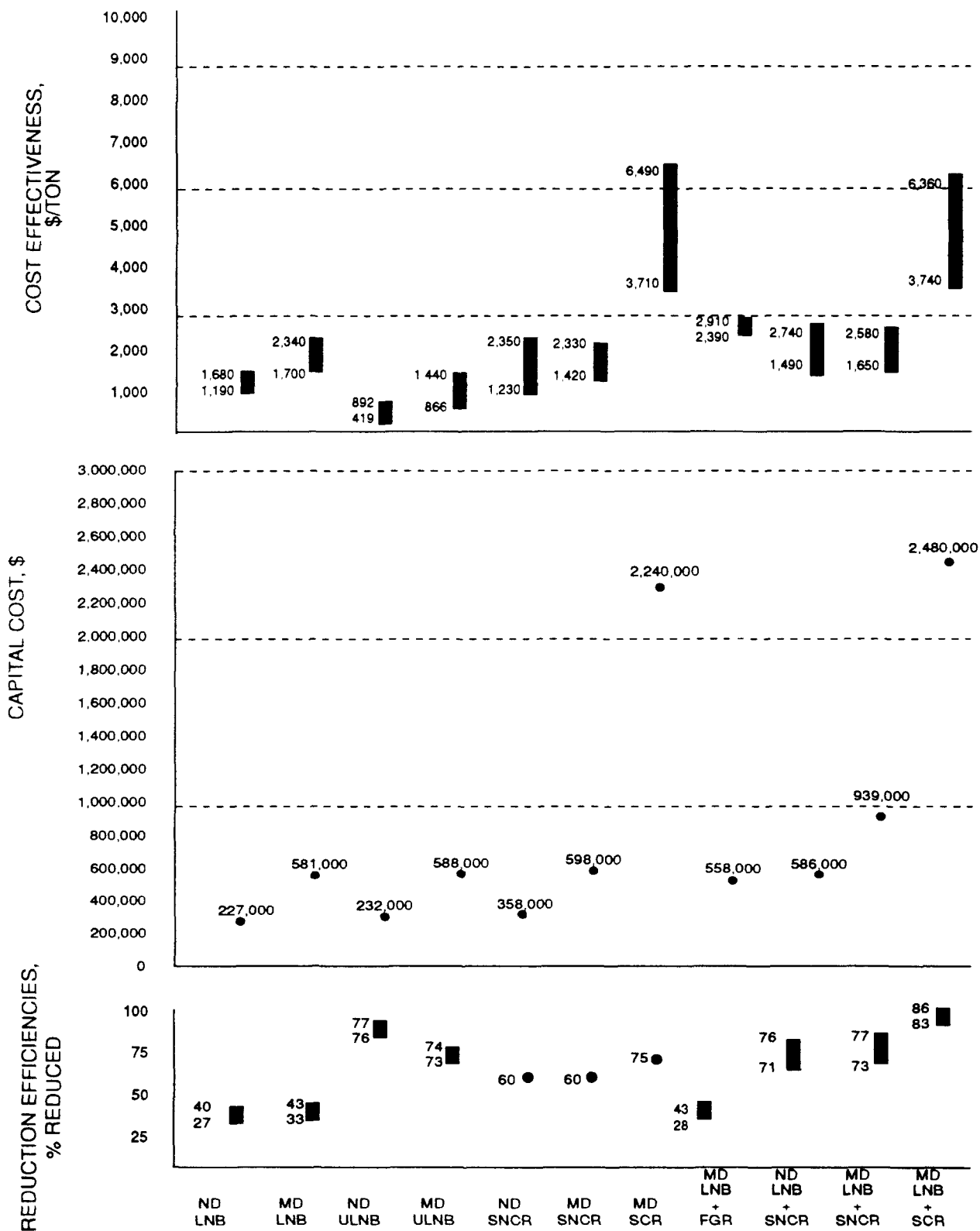

Figure 2-3. Model heaters: NO<sub>x</sub> emission reductions, capital costs, and cost effectiveness at a capacity factor of 0.9 for ND, oil-fired, low- and medium-temperature heaters.

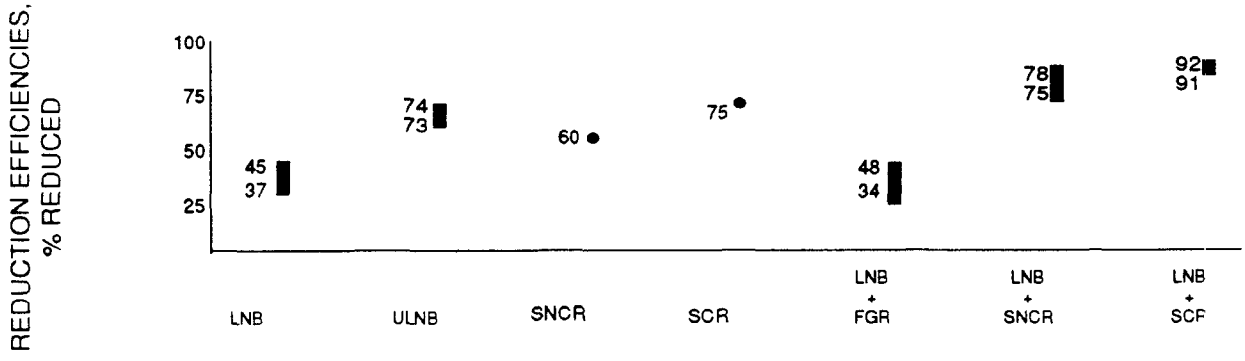
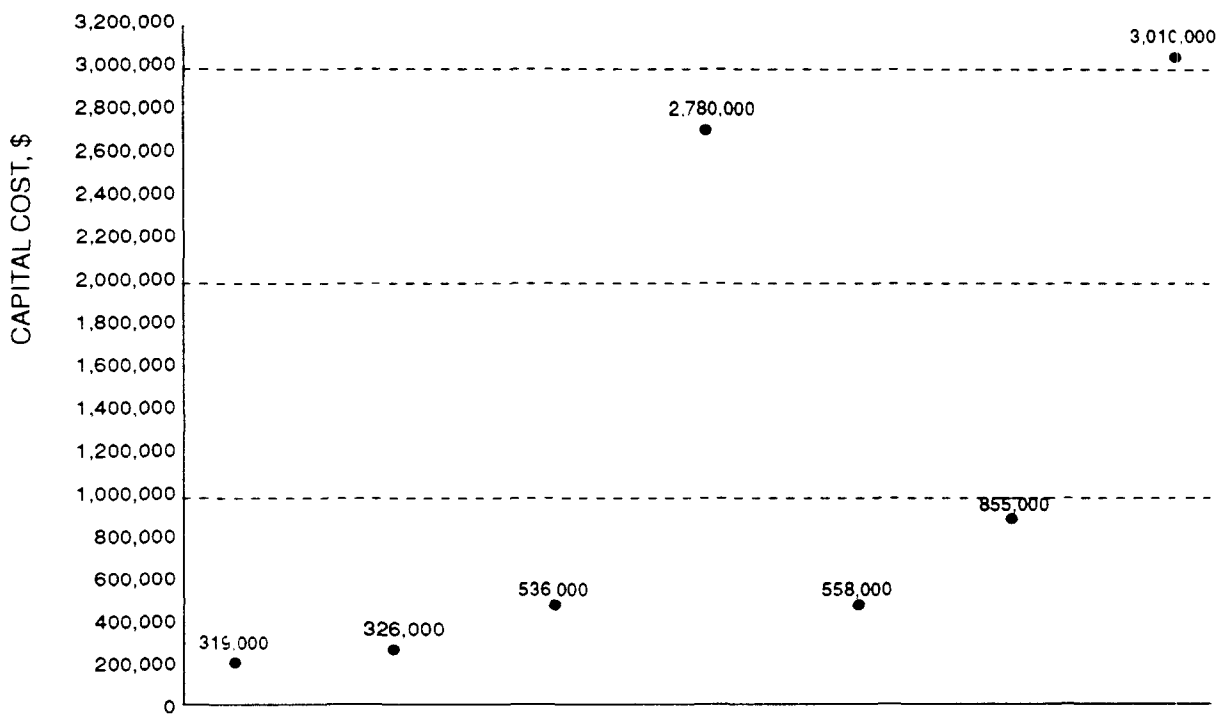
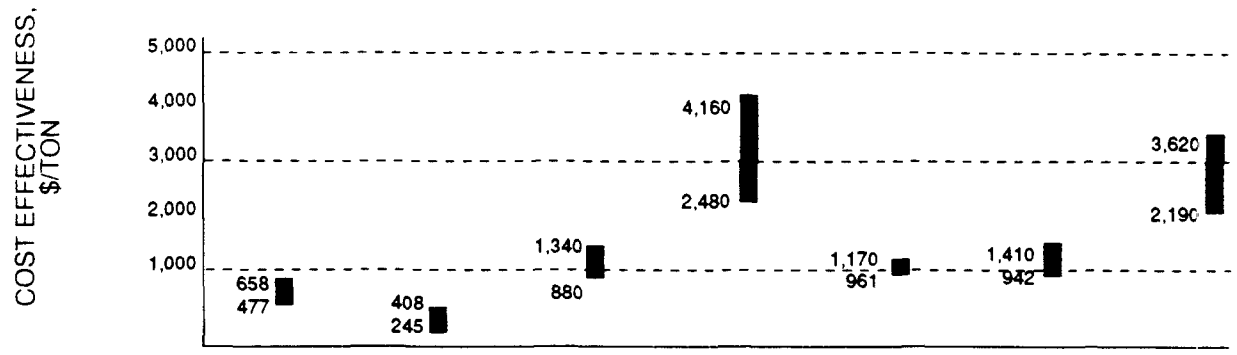

Figure 2-4. Model heaters: NO<sub>x</sub> emission reductions, capital costs, and cost effectiveness at a capacity factor of 0.9 for MD, oil-fired, low- and medium-temperature heaters.

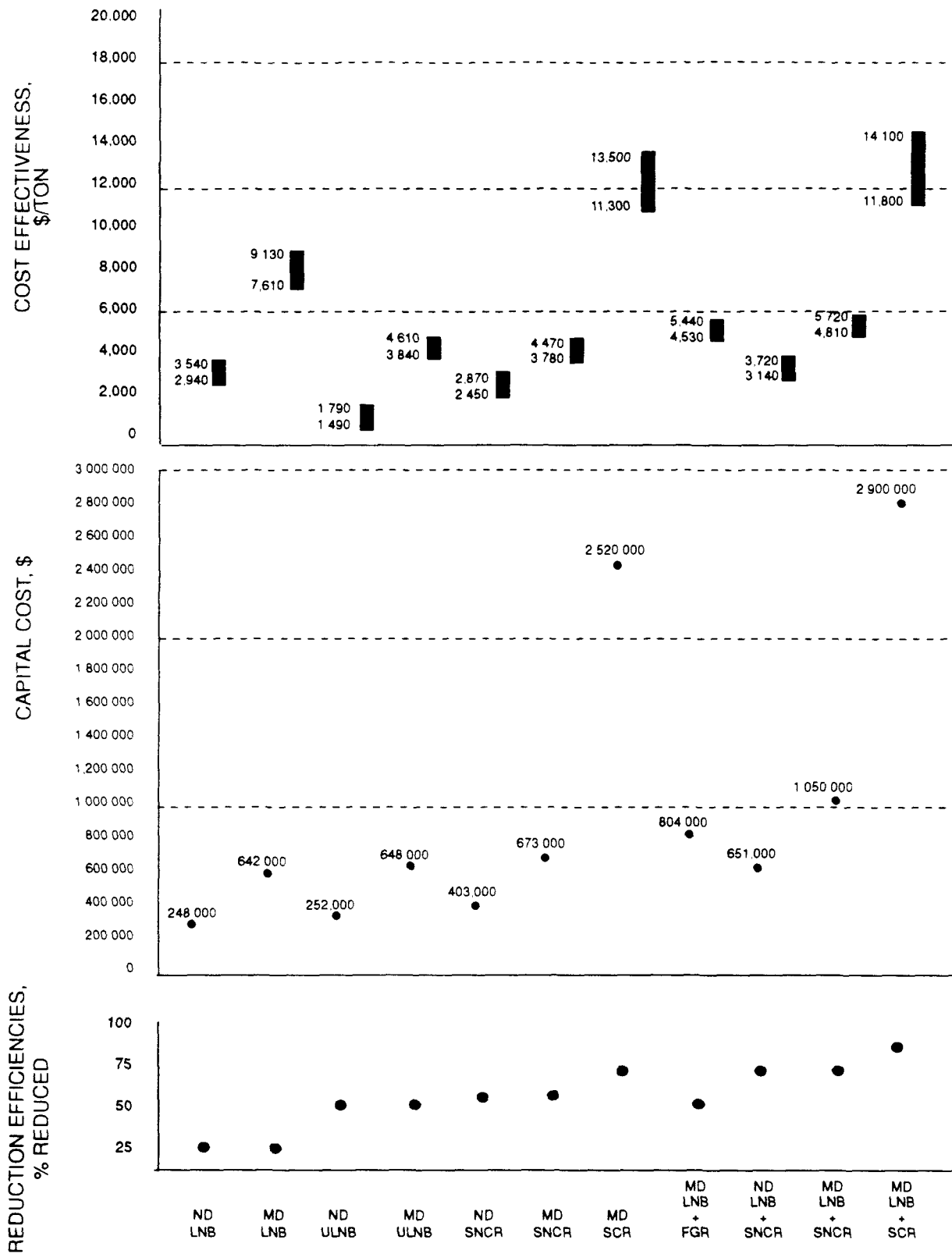

Figure 2-5. Model heaters: NO<sub>x</sub> emission reductions, capital costs, and cost effectiveness at a capacity factor of 0.9 for ND olefins pyrolysis heaters.



## 2.4 IMPACTS OF NO<sub>x</sub> CONTROLS

The use of NO<sub>x</sub> control techniques may cause environmental and energy impacts. Environmental impacts associated with combustion controls include carbon monoxide (CO) and unburned hydrocarbon (HC) emissions. Environmental impacts of postcombustion techniques include NH<sub>3</sub>, CO, and nitrous oxide (N<sub>2</sub>O) emissions with the use of SNCR; NH<sub>3</sub> and sulfite (SO<sub>3</sub>) emissions and solid waste disposal concerns with the use of SCR. Ammonia handling and storage also presents safety concerns with SNCR and SCR.

Energy impacts include additional electric energy requirements for fans or blowers and thermal efficiency losses. Thermal efficiency losses result in increased fuel consumption. These impacts are described briefly below.

Combustion controls, such as LNB, ULNB, and FGR, modify the combustion conditions to reduce the amount of NO<sub>x</sub> formed. Combustion controls are usually operated in such a manner that reduces NO<sub>x</sub> without producing unacceptable levels of CO and HC. Combustion controls reduce NO<sub>x</sub> formation by reducing the peak flame temperature and/or O<sub>2</sub> concentrations in the flame zone. Reductions in NO<sub>x</sub> formation achieved by reducing flame temperature and O<sub>2</sub> levels can increase CO and HC emissions if NO<sub>x</sub> reductions by combustion controls are taken to extremes.

The use of SNCR results in emissions of unreacted NH<sub>3</sub> and increases in CO and N<sub>2</sub>O emissions. Reactant-to-NO<sub>x</sub> ratios of 1.25 to 2.0:1 are typical of SNCR systems. The high ratio results in unreacted NH<sub>3</sub> emissions, or NH<sub>3</sub> slip. Carbon monoxide and N<sub>2</sub>O have been shown to be byproducts of urea injection. Unreacted NH<sub>3</sub> and N<sub>2</sub>O are byproducts of NH<sub>3</sub> injection. Selective catalytic reduction NH<sub>3</sub> slip concentrations are generally less than SNCR NH<sub>3</sub> slip concentrations because the catalytic reactor allows a higher reaction rate and lower reactant-to-NO<sub>x</sub> injection ratio (1.05:1 or less). Most catalysts used in SCR systems controlling process heaters in refinery service contain titanium and vanadium oxides. Catalyst formulations developed in the early 1980's tend to convert up to 5 percent of any sulfur

dioxide ( $\text{SO}_2$ ) present in high-sulfur fuels to  $\text{SO}_3$ , resulting in  $\text{SO}_3$  emissions. Newer catalyst formulations that convert less than 1 percent  $\text{SO}_2$  to  $\text{SO}_3$  are available and have been demonstrated in utility applications.

Safety concerns for  $\text{NH}_3$  storage and transport are due to the hazardous nature of concentrated  $\text{NH}_3$  vapor. Aqueous  $\text{NH}_3$  ( $\text{NH}_3$  in a liquid solution at atmospheric pressure) is not considered as hazardous as anhydrous  $\text{NH}_3$ , which is stored as a concentrated pressurized vapor. Aqueous  $\text{NH}_3$  is available for SCR and  $\text{NH}_3$  SNCR processes.

State and local regulatory agencies may classify catalysts containing vanadium pentoxide as a hazardous waste, however, and require disposal of these catalyst materials in an approved hazardous waste disposal facility. Such disposal problems are not encountered with other catalyst materials, such as precious metals and zeolites, because these materials are not considered hazardous wastes.

Control techniques that require upgraded or newly installed fans and blowers increase the electrical energy consumption for process heaters using those control techniques. These control techniques are LNB plus SCR, LNB plus FGR and ND heaters converted to MD for MD LNB or MD ULNB use.

Current combustion controls balance  $\text{NO}_x$  reduction with acceptable fuel efficiency. Adding LNB, ULNB, and LNB plus FGR may cause flames instability and reduced combustion efficiency. However, these impacts are minimal in properly designed systems. Injecting reactants into the flue gas stream in SNCR systems produces approximately a 0.3 percent thermal efficiency loss. The injection of reactants and the pressure drop across the catalyst in SCR systems produces approximately a 1.5 percent thermal efficiency loss. Thermal efficiency losses generally result in increased fuel consumption.

### 3.0 PROCESS HEATER DESCRIPTION AND INDUSTRY CHARACTERIZATION

This chapter describes process heaters and characterizes the industries typically using them. Process heaters are used in the petroleum refining and petrochemical industries, with minor applications in the fibers, iron and steel, gas processing, and other industries.<sup>1</sup> Detailed technical descriptions of design parameters, operations, and applications of process heaters are presented in Section 3.1. The two main industries using process heaters, petroleum refining operations and chemical manufacturing facilities, are characterized in Section 3.2.

#### 3.1 PROCESS HEATER DESCRIPTION

Process heaters (also known as process furnaces and direct-fired heaters) are heat transfer units in which heat from fuel combustion is transferred predominantly by radiation and secondarily by convection to fluids contained in tubes.<sup>1</sup> Process heaters are generally used in heat transfer applications where steam heaters (i.e., boilers) are inappropriate. These include applications in which heat must be transferred at temperatures in excess of 90° to 204°C (200° to 400°F). The process fluid stream to be heated is contained in single-fired tubes along the radiant section walls and ceiling, in two-sided fired tubes within the radiant section, and in convection section tubes of the process heater combustion chamber. This process fluid stream is heated for one of two reasons: (1) to raise the temperature for additional processing (heated feed), or (2) so that chemical reactions may occur in the tubes (reaction feed). Sections 3.1.1 and 3.1.2 contain more information on these two types of process heaters.

### 3.1.1 Heated Feed

Process heaters whose function is to heat a process fluid stream before additional processing include distillation column feed preheaters and reboilers, reactor feed preheaters, hot oil furnaces, and viscous fluid heaters.<sup>1</sup> This type of process heater is found in both the petroleum refining and chemical manufacturing industries.

Fired heaters are used in the petroleum refining industry principally as preheaters for various operations such as distillation, catalytic cracking, hydroprocessing, and hydroconversion.<sup>2</sup> Fired heaters are used in a wide variety of applications in the chemical manufacturing industry. They are used as fired reactors (e.g., steam-hydrocarbon reformers and olefins pyrolysis furnaces), feed preheaters for nonfired reactors, reboilers for distillation operations, and heaters for heating transfer oils.<sup>3</sup>

### 3.1.2 Reaction Feed

Chemical reactions occur inside the tubes of many process heaters upon heating. Applications include steam-hydrocarbon reformers used in ammonia and methanol manufacturing, pyrolysis furnaces used in ethylene manufacturing, and thermal cracking units used in refining operations.<sup>1</sup>

### 3.1.3 Process Heater Design Parameters

Process heaters may be designed and constructed in a number of ways, but most process heaters include burner(s), combustion chamber(s), and tubes that contain process fluids. Sections 3.1.3.1 through 3.1.3.4 describe combustion chamber set-ups, combustion air supply, tube configurations, and burners, respectively.

3.1.3.1 Combustion Chamber Set-Ups. Process heaters contain a radiant heat transfer area in the combustion chamber. This area heats the process fluid stream in the tubes by flame radiation. Equipment found in this area includes the burner(s) and the combustion chamber(s). Most heat transfer to the process fluid stream occurs here, but these tubes do not necessarily constitute a majority of the tubes in which the process fluid

flows. A typical process heater displaying this equipment is shown in Figure 3-1.<sup>4</sup>

Most process heaters also use a convective heat transfer section to recover residual heat from the hot combustion gases by convective heat transfer to the process fluid stream.<sup>4</sup> This section is located after the radiant heat transfer section and also contains tubes filled with process fluid. The first few rows of tubes in this section are called shield tubes and are subject to some radiant heat transfer. Typically, the process fluid flows through the convective section prior to entering the radiant section in order to preheat the process fluid stream. The temperature of the flue gas upon entering the convective section usually ranges from 800° to 1000°C (1500° to 2000°F).<sup>5,6</sup> Preheating in the convective section improves the efficiency of the process heater, particularly if the tube design includes fins or other extended surface areas. An extended tube surface area can improve efficiency by 10 percent.<sup>7</sup> Extended tubes can reduce flue gas temperatures from 800° to 1010°C (1500° to 2000°F) to 120° to 260°C (250° to 500°F).<sup>6</sup>

3.1.3.2 Combustion Air Supply. Combustion air is supplied to the burners via natural draft (ND) or mechanical draft (MD) systems. Natural draft heaters use duct work systems to route air, usually at ambient conditions, to the burners. Mechanical draft heaters use fans in the duct work system to supply air, usually preheated, to the burners. The combustion air supply must have sufficient pressure to overcome the burner system pressure drops caused by ducting, burner registers, and dampers. The pressure inside the firebox is generally a slightly negative draft of approximately 49.8 to 125 Pascals (Pa) (0.2 to 0.5 inch of H<sub>2</sub>O [in. H<sub>2</sub>O]) at the radiant-to-convective section transition point. The negative draft is achieved in ND systems via the stack effect and in MD systems via fans or blowers.<sup>6</sup>

Natural draft combustion air supply uses the stack effect to induce the flow of combustion air in the heater. The stack effect, or thermal buoyancy, is caused by the density difference

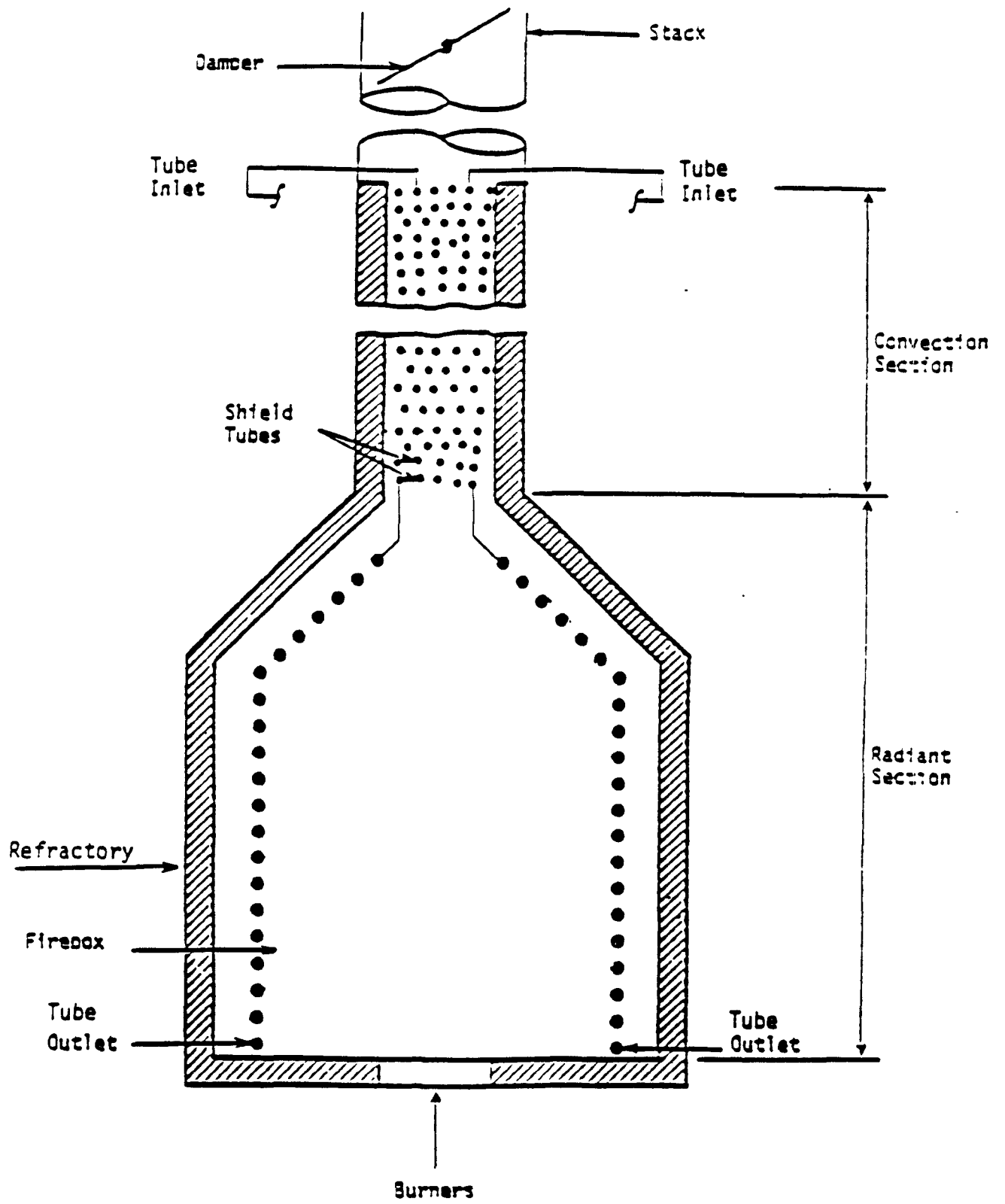

Figure 3-1. Cross-section of a typical process heater.<sup>4</sup>

between the hot flue gas in the stack and the significantly cooler ambient air surrounding the stack.<sup>6</sup> Approximately 90 percent of all gas-fired heaters and 76 percent of all oil-fired heaters use ND combustion air supply.<sup>7</sup>

There are three types of MD combustion air supply: forced draft, induced draft, and balanced draft. The draft types are named according to the position, relative to the combustion chamber, of the fans used to create pressure difference in the process heater. All three types of MD heaters rely on the fans to supply combustion air and remove flue gas. In forced draft combustion air systems, the fan is located upstream from the combustion chamber, supplying combustion air to the burners. The air pressure supplied to the burners in a forced draft heater is typically in the range of 0.747 to 2.49 kilopascals (kPa) (3 to 10 in. H<sub>2</sub>O).<sup>8</sup> Though combustion air is supplied to the burners under positive pressure, the remainder of the process heater operates under negative pressure caused by the stack effect. In induced draft combustion air systems, the fan is located downstream of the combustion chamber, creating negative pressure inside the combustion chamber. This negative pressure draws, or induces, combustion air into the burner registers. Balanced draft combustion air systems use fans placed both upstream and downstream (forced and induced draft) of the combustion chamber.<sup>8</sup>

There are advantages and disadvantages for both ND and MD combustion air supply. Natural draft heaters do not require the fans and equipment associated with MD combustion air supply. Though simpler, ND heaters do not allow as precise control of combustion air flow as do MD heaters. Mechanical draft heaters, unlike ND heaters, provide the option of using alternate sources of combustion oxygen, such as gas turbine exhaust, and the use of combustion air preheat.<sup>8</sup> Combustion air preheat has limited application in ND heaters due to the pressure drops associated with combustion air preheaters.

Combustion air preheaters are often used to increase the efficiency of MD process heaters. The maximum thermal efficiency obtainable with current air preheat equipment is 92 percent.<sup>9</sup>

Preheaters allow heat to be transferred to the combustion air from flue gas, steam, condensate, hydrocarbon, or other hot streams.<sup>6</sup> The preheater increases the efficiency of the process heater because some of the thermal energy is reclaimed that would have been exhausted from the hot streams via cooling towers. If the thermal energy is from the heater's flue gas, the heater efficiency is increased. If the thermal energy is from a hot stream other than the flue gas, the entire plant's efficiency is increased. The benefit of higher thermal efficiency is that less fuel is required to operate the heater.<sup>6</sup>

3.1.3.3 Tube Configurations. The orientation of the tubes through which a process fluid stream flows is also taken into consideration when designing a process heater. The tubes in the convective section are oriented horizontally in most process heaters to allow crossflow convection. However, the tubes in the radiant area may be oriented either horizontally or vertically. The orientation is chosen on a case-by-case basis according to the design specifications of the individual process heater. For example, the arbor, or wicket, type of fired heater is a specialty design to minimize the pressure drop across the tubes.<sup>4,6</sup> Figure 3-2 displays some of the tube orientation options available.

3.1.3.4 Burners. Many different types of burners are used in process heaters. Burner selection depends upon several factors including process heat flux requirements, fuel type, and draft type.<sup>11</sup> The burner chosen must provide a radiant heat distribution that is consistent with the configuration of the tubes carrying process fluid. Also, the number and location of the burner(s) depends on the process heater application.<sup>11</sup>

Many burner flame shapes are possible, but the most common types are flat and conical. Flat flames are generally used in applications that require high temperatures such as ethylene pyrolysis furnaces, although some ethylene furnaces use conical flames to achieve uniform heat distribution.<sup>6,11</sup> Long conical flames are used in cases where a uniform heat distribution is needed in the radiant section.<sup>11</sup>



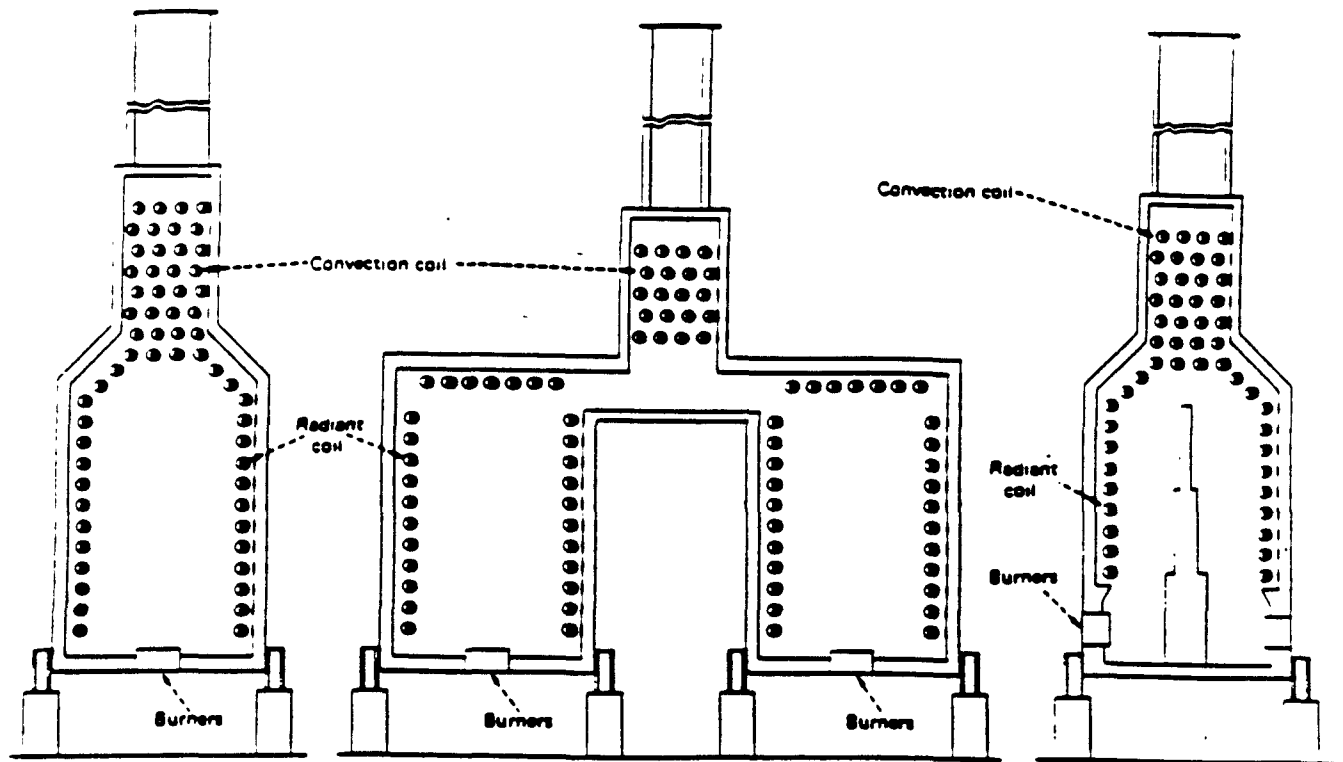

a. Cabin

b. Two-cell box

c. Cabin with dividing bridgewall

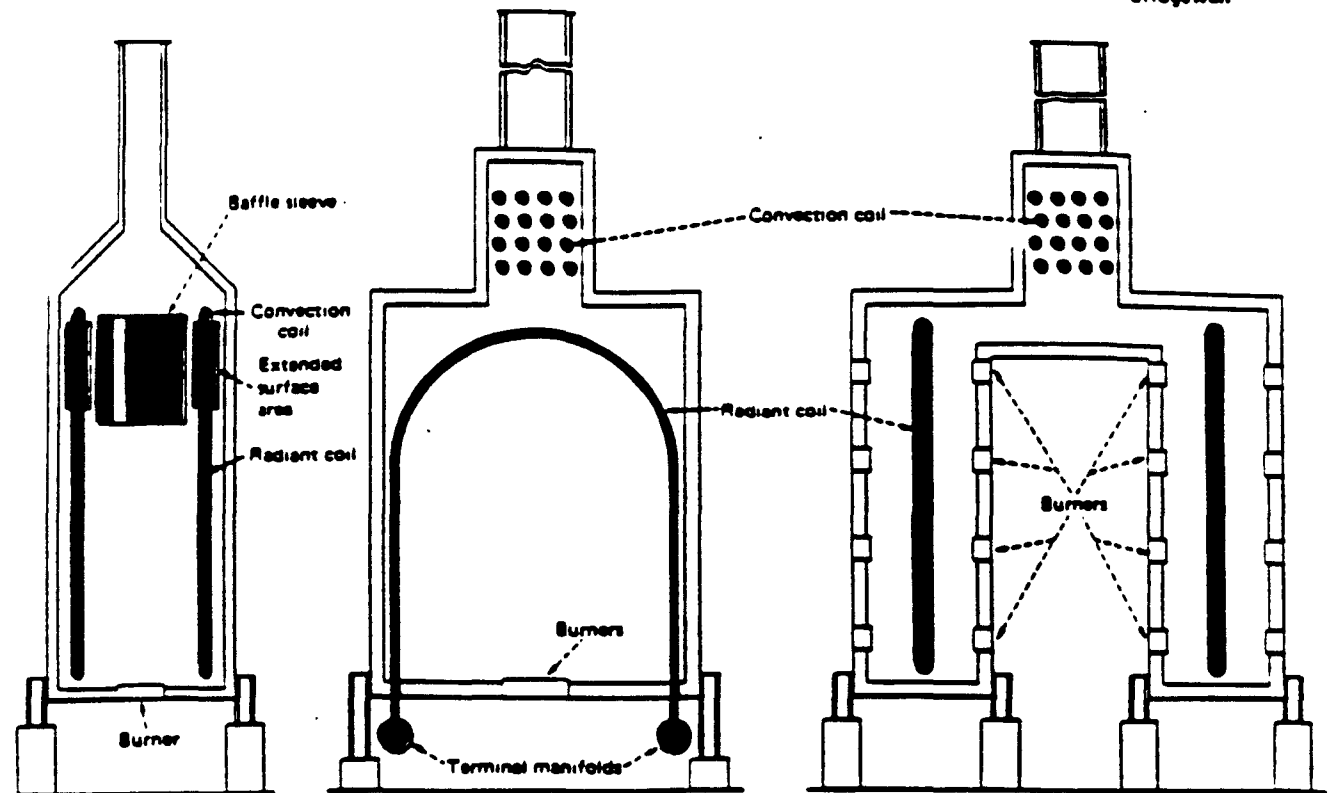

d. Vertical-cylindrical with integral convection section

e. Arbor or wetkat type

f. Vertical-tube, single-row, double-fired

Figure 3-2. Examples of radiant section tube orientations.<sup>10</sup>

Fuel compatibility is also important in burner selection. Burners may be designed for combustion of oil, gas, or a gas/oil mixture. Figure 3-3 shows typical burners found in process heaters. Gas-fired burners are simpler in operation and design than oil-fired burners and are classified as either premix or raw gas burners. In premix burners, 50 to 60 percent of the air necessary for combustion is mixed with the gas prior to combustion at the burner tip. This air is induced into the gas stream as the gas expands through orifices in the burner. The remainder of the air necessary for combustion is provided at the burner tip. Raw gas burners receive fuel gas without any premixed combustion air. Mixing occurs in the combustion zone at the burner tip.<sup>12</sup>

Oil-fired burners are classified according to the method of fuel atomization used. Atomization is needed to increase the mixing of fuel and combustion air. Three types of fuel atomization commonly used are mechanical, air, and steam. Steam is the most widely used method because it is the most economical, provides the best flame control, and can handle the largest turndown ratios. Typical steam requirements are 0.07 to 0.16 kilogram (kg) steam/kg of oil.<sup>13</sup>

Combination burners can burn 100 percent oil, 100 percent gas, or any combination of oil and gas. A burner with this capability generally has a single oil nozzle in the center of a group of gas nozzles. The air needed for combustion can be controlled separately in this type of burner. Another option available is to baseload the burners with one fuel and to add the other fuel to meet increases in load demand. Combination burners add flexibility to the process heater, especially when the composition of the fuel is variable.<sup>15</sup>

The location and number of burners needed for a process heater are also determined on an individual basis. Burners can be located on the ceiling, walls, or floor of the combustion chamber. Floor- and wall-fired units are the most common burner types found in process heaters because they are both efficient and flexible. In particular, floor-mounted burners integrate

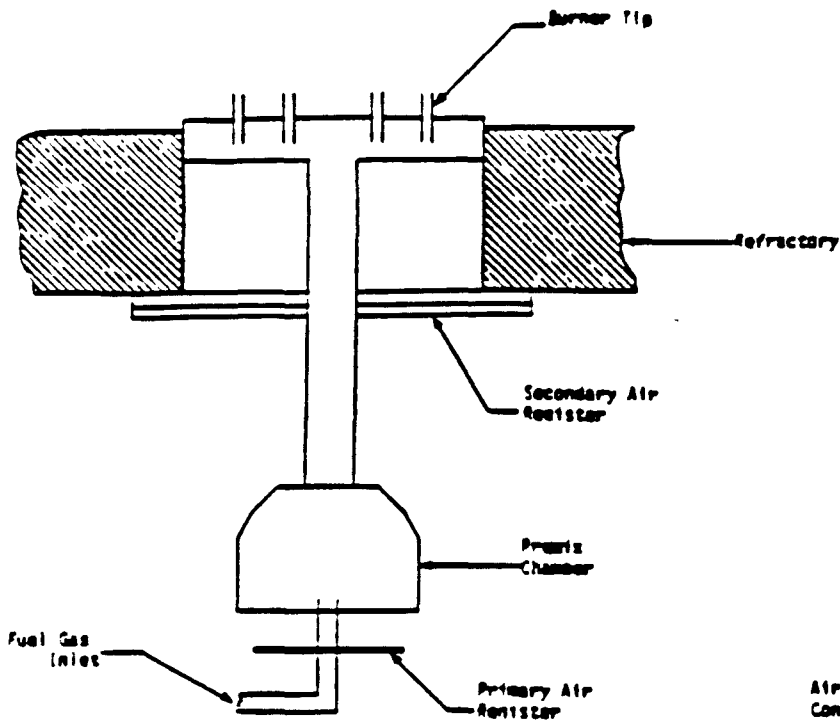

a. Premix Burner

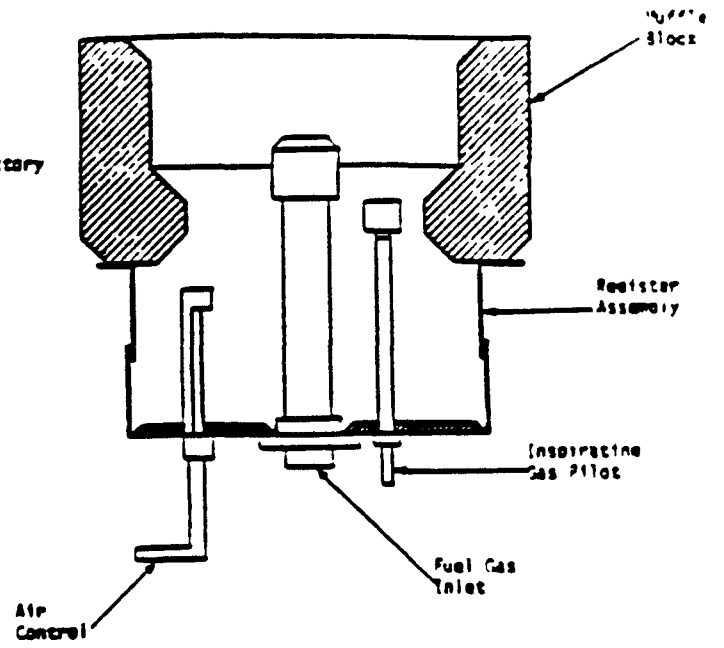

b. Raw Gas Burner

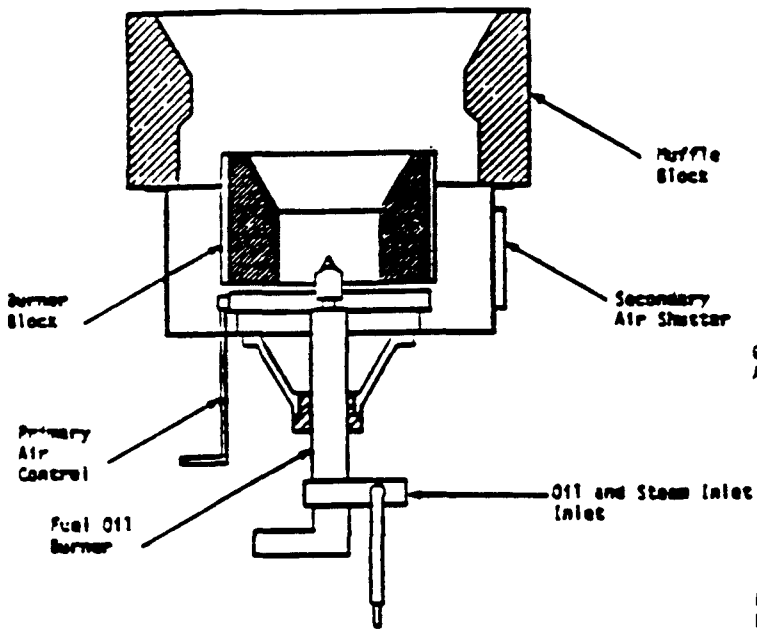

c. Oil Burner

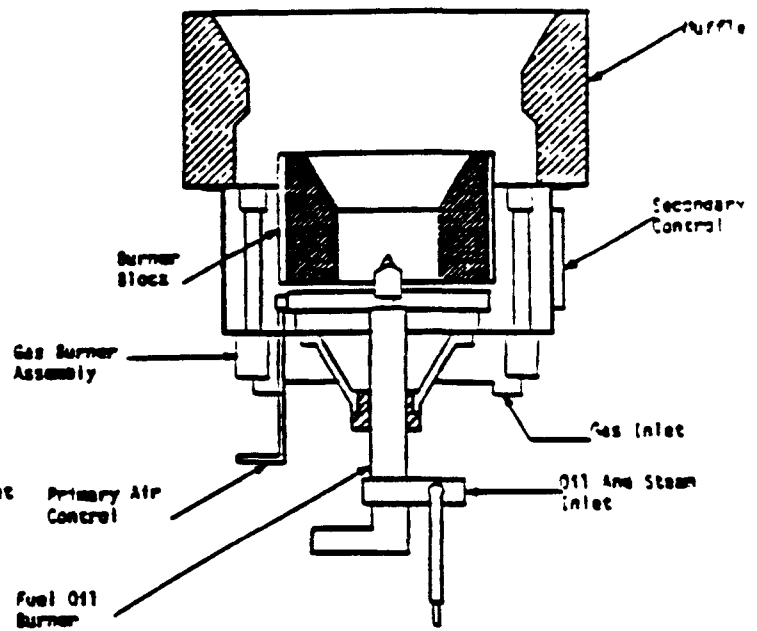

d. Combination Oil and Gas Burner

Figure 3-3. Typical burners by type of fuel burned.<sup>14</sup>

well with the use of combustion air preheat, liquid fuels, and alternate sources of combustion oxygen such as turbine exhaust.<sup>15</sup>

The number of burners in a heater can range from 1 to over 100. In the refinery industry, the average number of burners is estimated at 24 in ND heaters with an average design heat release of 69.4 million British thermal units per hour (MMBtu/hr). The average number of burners is estimated at 20 in MD heaters with ambient combustion air and an average design heat release of 103.6 MMBtu/hr. The average number of burners is estimated at 14 in MD heaters with combustion air preheat and an average design heat release of 135.4 MMBtu/hr.<sup>16</sup> In general, the smaller the number of burners, the simpler the heater will be. However, multiple burners provide a more uniform temperature distribution.

### 3.2 INDUSTRY CHARACTERIZATION

Statistical information on the two primary industries using process heaters (the petroleum refining industry and the chemical manufacturing industry) is contained in this section. The statistical information includes the number and size of process heaters in use by these industries, specific operations in each industry that require process heaters, and energy consumption projections for process heaters in these industries.

#### 3.2.1 Process Heaters in Use

According to the annual refining survey published in the Oil and Gas Journal, there were 194 operating refineries in the United States as of January 1, 1991.<sup>17</sup> Most of the heaters in oil refineries are ND (89.6 percent), and the remaining heaters are MD, both without preheat (8.0 percent) and with preheat (2.4 percent). The mean size of all process heaters is 72 MMBtu/hr, while the mean size of MD heaters is 110 MMBtu/hr<sup>2</sup>. Figure 3-4 presents the size distribution breakdown for this industry. Based on a comparison of similar information from 1985, it is evident that growth in the refining industry has been modest over the last 5 years. In 1985, there were 191 operating refineries in the United States ranging in capacity from 4,000 barrels crude oil per calendar day (bbl/d) to

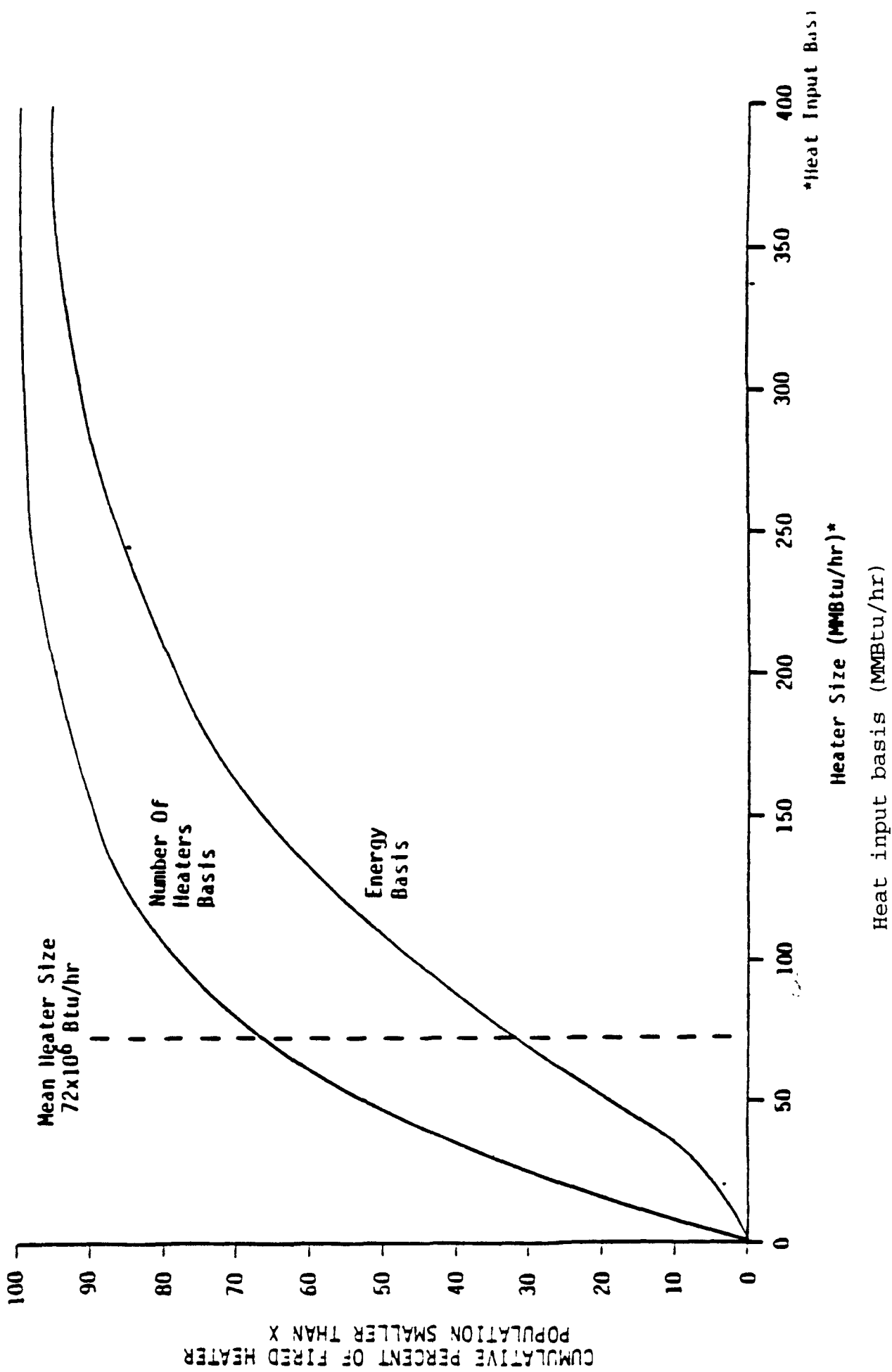

Figure 3-4. Size distribution of the existing fired heater population. 18

494,000 bbl/d.<sup>19</sup> As of January 1, 1991, the capacity range was 2,500 bbl/d to 433,000 b/d.<sup>17</sup> This lower capacity range, coupled with an increase in total production capacity of 379,000 bbl/d (1985, 15.1 million bbl/d; 1991, 15.5 million bbl/d), provides evidence of growth in small to mid-size plants and a trend towards reductions in large facility production capacity. Table 3-1 provides a breakdown of the number of refineries and total crude capacity (bbl/d) in each State.

In 1980, the American Petroleum Institute (API) estimated the total number of process heaters in the petroleum refining industry to be about 3,200.<sup>20</sup> The number of process heaters at refineries varies in that large, integrated facilities may have as many as 100 process heaters, and small refineries may have as few as 4.<sup>2</sup>

The total number of chemical industry fired heaters was estimated to be 1,400 in 1985. This number was estimated by dividing the annual energy demand of the chemical industry fired heaters in major applications ( $6.8 \times 10^{14}$  MMBtu/yr) by the average-sized chemical industry fired heater (56.1 MMBtu/hr) as reported by the Chemical Manufacturers Association.<sup>21</sup>

### 3.2.2 Process Heater Energy Consumption

The predominant uses of process heaters in the petroleum refining industry are as preheaters for distillation, catalytic cracking, hydroprocessing, and hydroconversion. Table 3-2 gives a more detailed breakdown of these operations. The total annual energy consumption for process heaters in 1973 for the petroleum refining industry was  $2.0 \times 10^{15}$  Btu/yr, and in 1985 it increased to  $2.2 \times 10^{15}$  Btu/yr.<sup>23</sup> Because the most current information found was 1985 data, a growth projection was calculated based on the latest trends. Assuming a linear growth extrapolation (i.e., same slope as that of the 1973 to 1985 data), annual energy consumption for 1991 was estimated to be  $2.3 \times 10^{15}$  Btu/yr. Figure 3-5 displays the growth estimate for the petroleum refining industry energy consumption, based on the 1985 information.

TABLE 3-1. SURVEY OF OPERATING REFINERIES IN THE U.S.<sup>17</sup>  
(State capacities as of January 1, 1991)

State	No. of plants	Crude capacity, bbl/d
Alabama	4	166,000
Alaska	6	243,000
Arizona	2	14,200
Arkansas	3	60,500
California	30	2,210,000
Colorado	3	91,200
Delaware	1	140,000
Georgia	2	35,500
Hawaii	2	143,000
Illinois	7	973,000
Indiana	4	427,000
Kansas	8	351,000
Kentucky	2	219,000
Louisiana	19	2,330,000
Michigan	4	124,000
Minnesota	2	286,000
Mississippi	5	359,000
Montana	4	136,000
Nevada	1	4,500
New Jersey	6	494,000
New Mexico	4	77,300
New York	1	39,900
North Dakota	1	58,000
Ohio	4	454,000
Oklahoma	7	409,000
Oregon	1	N/A
Pennsylvania	7	731,000
Tennessee	1	60,000
Texas	31	3,880,000
Utah	6	155,000
Virginia	1	53,000
Washington	7	521,000
West Virginia	2	29,700
Wisconsin	1	32,000
Wyoming	5	165,000
TOTAL	194	15,500,000

N/A = Not available.

TABLE 3-2. MAJOR REFINERY PROCESSES REQUIRING A FIRED HEATER<sup>22</sup>

Process	Process description	Heaters used	Process heat requirements		Feedstock temperature outlet of heater, °F
			KJ/liter	10 <sup>3</sup> Btu/bbl feed	
Distillation					
Atmospheric	Separates light hydrocarbons from crude in a distillation column under atmospheric conditions.	Preheater, reboiler	590	89	700
Vacuum	Separates heavy gas oils from atmospheric distillation bottoms under vacuum.	Preheater, reboiler	418	63	750-830
Thermal processes					
Thermal cracking	Thermal decomposition of large molecules into lighter, more valuable products.	Fired reactor	4,650	700	850-1,000
Coking	Cracking reactions allowed to go to completion. Lighter products and coke produced.	Preheater	1,520	230	900-975
Visbreaking	Mild cracking of residuals to improve their viscosity and produce lighter gas oils.	Fired reactor	961	145	850-950
Catalytic cracking					
Fluidized catalytic cracking	Cracking of heavy petroleum products. A catalyst is used to aid the reaction.	Preheater	663	100	600-885
Catalytic hydrocracking	Cracking heavy feedstocks to produce lighter products in the presence of hydrogen and a catalyst.	Preheater	1,290	195	400-850
Hydroprocessing					
Hydrosulfurization	Remove contaminating metals, sulfur, and nitrogen from the feedstock. Hydrogen is added and reacted over a catalyst.	Preheater	431	65 <sup>a</sup>	390-850
Hydrotreating	Less severe than hydrosulfurization. Removes metals, nitrogen, and sulfur from lighter feedstocks. Hydrogen is added and reacted over a catalyst.	Preheater	497	75 <sup>b</sup>	600-800
Hydroconversion					
Alkylation	Combination of two hydrocarbons to produce a higher molecular weight hydrocarbon. Heater used on the fractionator.	Reboiler	2,500	377 <sup>c</sup>	400
Catalytic reforming	Low-octane naphthas are converted to high-octane, aromatic naphthas. Feedstock is contacted with hydrogen over a catalyst.	Preheater	1,790	270	850-1,000

<sup>a</sup>Heavy gas oils and middle distillates.

<sup>b</sup>Light distillate.

<sup>c</sup>Btu/bbl of total alylate.



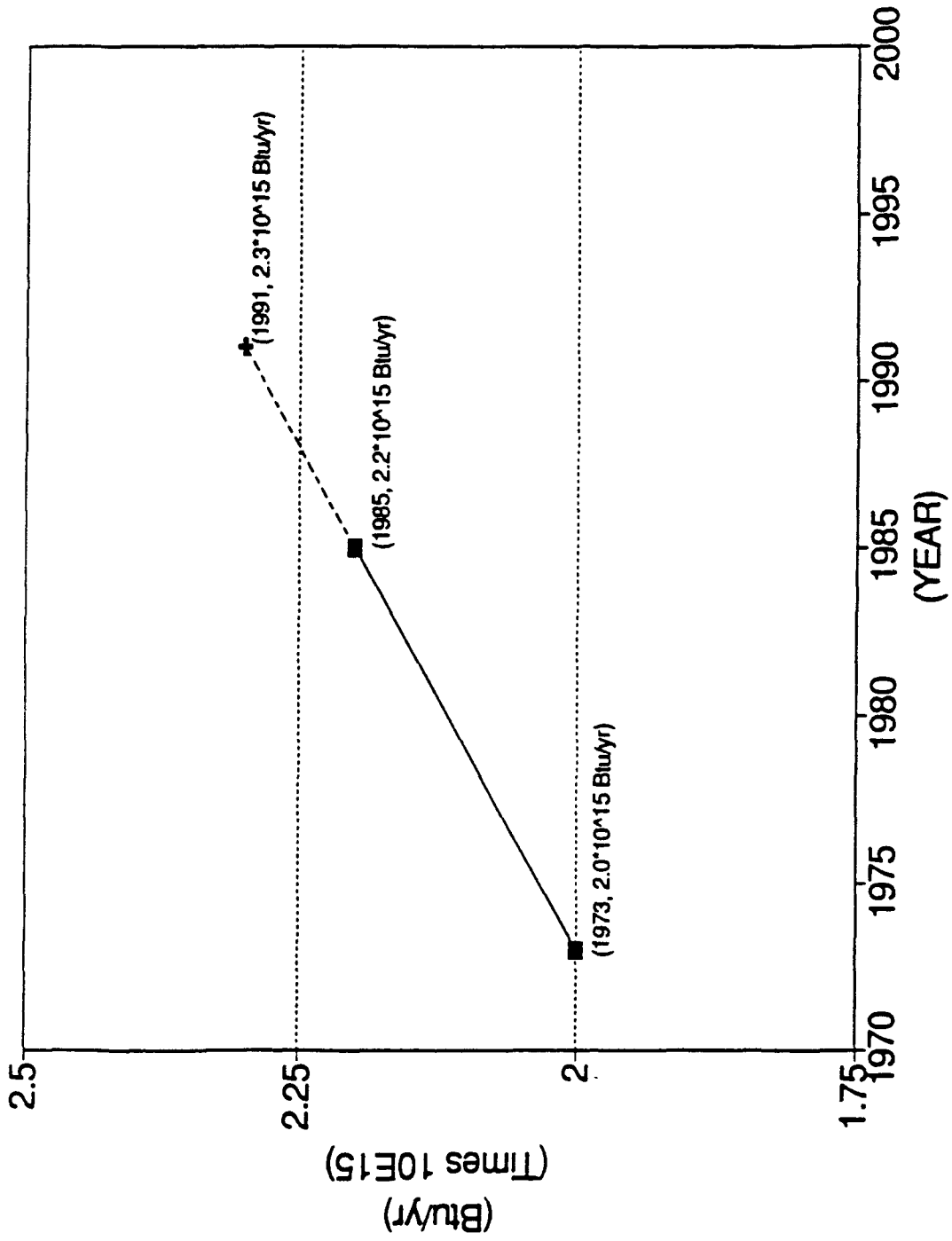

Figure 3-5. Annual energy consumption projection for process heaters used in petroleum refining.<sup>23</sup>

The known energy requirement of the major chemical industry fired heater applications in 1985 was  $6.5 \times 10^{14}$  Btu/yr and is shown in Table 3-3.<sup>3</sup> As discussed earlier, the estimated energy requirement for 1985 was  $6.8 \times 10^{14}$  Btu/yr.<sup>21</sup> Thirty organic and seven inorganic operations require process heaters in the chemical manufacturing industry.<sup>3</sup> Table 3-4 lists these operations. On the basis of process requirements, fired heater applications in the chemical industry can be broadly classified into two categories: low- and medium-firebox-temperature applications, such as feed preheaters, reboilers, and steam superheaters; and high firebox temperature applications, such as olefins pyrolysis furnaces and steam-hydrocarbon reformers. Low- and medium-firebox temperature heaters represent approximately 20 percent of the chemical industry heater requirements and are similar to those found in the petroleum refining industry.<sup>3</sup> High-firebox-temperature heaters represent approximately 80 percent of the chemical industry heater requirements and are unique to the chemical industry.

High-temperature pyrolysis fired heater applications represent approximately 50 percent of the chemical industry heater requirements. Gaseous hydrocarbons such as ethane, propane, and butane and heavier hydrocarbons such as naphtha feedstocks are thermally converted to olefins such as ethylene and propylene. The following are basic criteria for pyrolysis: adequate control of heat flux from inlet to outlet of the tubes, high heat transfer rates at high temperatures, short residence times, and uniform temperature distribution along the tube length. The firebox temperatures for pyrolysis furnaces range from 1050° to 1250°C (1900° to 2300°F).<sup>3,6</sup>

Steam-hydrocarbon reformers represent approximately 27 percent of the chemical industry heaters requirements. The function of these furnaces is to reform natural gas or other hydrocarbons with steam to produce hydrogen and carbon monoxide. The reforming reactions are not favored by conditions below 590°C (1100°F) and proceed more favorably as the temperature increases.

TABLE 3-3. ENERGY REQUIREMENTS OF MAJOR FIRED HEATER APPLICATIONS IN THE CHEMICAL INDUSTRY<sup>24</sup>

Chemical	Process	Heater type	Firebox temperature (°F)	1985 fired heater energy requirement, 10 <sup>12</sup> Btu/yr	% of known chemical industry heater requirements
Low- and medium-temperature applications					
Benzene	Reformate extraction	Reboiler	700	64.8	9.9
Styrene	Ethylbenzene dehydrogenation	Steam superheater	1,500 - 1,600	32.1	4.9
Vinyl chloride monomer	Ethylene dichloride cracking	Cracking furnace	N/A	12.6	1.9
P-Xylene	Xylene isomerization	Reactor fired preheater	N/A	13.0	2.0
Dimethyl terephthalate	Reaction of p-xylene and methanol	Preheater, hot oil furnace	480 - 540	11.1	1.7
Butadiene	Butylene dehydrogenation	Preheater, reboiler	1,100	2.6	0.4
Ethanol (synthetic)	Ethylene hydration	Preheater	750	1.3	0.2
Acetone	Various	Hot oil furnace	N/A	0.8	0.1
Others	See Table 3-7				
High-temperature applications					
Ethylene/propylene	Thermal cracking	Pyrolysis furnace	1,900 - 2,300	337.9	51.8
Ammonia	Natural gas reforming	Steam hydrocarbon reformer	1,500 - 1,600	150.5	23.1
Methanol	Hydrocarbon reforming	Steam hydrocarbon	1,000 - 2,000	25.7	4.0
<b>TOTAL KNOWN FIRED HEATER ENERGY REQUIREMENT</b>				<b>652.4</b>	<b>100</b>

TABLE 3-4. REPORTED APPLICATIONS OF FIRED HEATERS  
IN THE CHEMICAL MANUFACTURING INDUSTRY<sup>25</sup>

Category	Applications
Organic chemicals manufacturing	Acetone, acetic anhydride, acetylene, acrylic acids, alkyl benzene, allyl chloride, amines, ammonia, benzenes, benzoic acid and other aromatic acids, biphenyl, butadiene, chlorinated hydrocarbon solvents, cumene, cyclohexane, dimethyl terephthalate, diphenylamine, esters, ethanol and higher alcohols, ethylbenzene/styrene, ethylene/propylene, fatty acids, formaldehyde, ketone, maleic anhydride, methanol, methyl ethyl ketone, methylene dianiline, neo acids, phthalic anhydride, polyethylene, polyvinyl chloride, pyridine, salicylic acid, toluene diamine, toluene diisocyanate, xylene
Inorganic chemicals manufacturing	Carbon bisulfite, carbon disulfide, carbon monoxide, caustic soda, hydrogen, silicones, sulfur chloride
Others	Additives, agricultural products, asphalt, carbon black, elastomers, fabrics, finishes, pharmaceuticals photo products, pigments, plasticizers, polyamide adhesives, synthetic fibers

The firebox temperature of steam-hydrocarbon reformers ranges from about 980° to 1100°C (1800° to 2000°F).<sup>21</sup>

### 3.3 REFERENCES FOR CHAPTER 3

1. Shareef, S.A., C.L. Anderson, and L.E. Keller (Radian Corporation). Fired Heaters: Nitrogen Oxides Emissions and Controls. Prepared for the U. S. Environmental Protection Agency. Research Triangle Park, NC. EPA Contract No. 68-02-4286. June 1988. pp. 9-10.
2. Reference 1, p. 25.
3. Reference 1, p. 32.
4. Reference 1, pp. 10-12.
5. Control Techniques for NO<sub>x</sub> Emissions from Stationary Sources--Revised Second Edition. U. S. Environmental Protection Agency. Research Triangle Park, NC. Publication No. EPA-450/3-83-002. January 1983. p. 5-33.
6. Letter and attachments from Eichamer, P., Exxon Chemical Company, to Neuffer, W., EPA/ISB. September 2, 1992. Comments on draft Alternative Control Techniques Document--Control of NO<sub>x</sub> Emissions from Process Heaters.
7. Reference 5, p. 5-35.
8. Reference 1, p. 14.
9. Reference 5, pp. 5-35 through 5-36.
10. Reference 1, p. 13.
11. Reference 1, p. 16.
12. Reference 1, p. 18.
13. Reference 5, p. 5-38.
14. Reference 1, p. 17.
15. Reference 1, p. 19.
16. Reference 1, pp. 19-20.
17. Thrash, L.A. Annual Refining Survey. Oil and Gas Journal. March 18, 1991. pp. 86-105.
18. Reference 1, p. 31.
19. Reference 1, p. 22.

20. Cherry, S.S., and S.C. Hunter (KVB-A Research-Cottrell Company). Cost and Cost-Effectiveness of NO<sub>x</sub> Control in Petroleum Industry Operations. Prepared for the American Petroleum Institute. Washington, D.C. API Publication No. 4331. October 1980. pp. 2-68 through 2-73.
21. Reference 1, p. 36.
22. Reference 1, p. 28.
23. Letter from Crockett, B.P., American Petroleum Institute, to Crowder, J.U., EPA/ISB. July 23, 1984. Review of Chapters 3 through 6 of NSPS BID draft.
24. Reference 1, p. 34.
25. Reference 1, p. 33.

## 4.0 CHARACTERIZATION OF NO<sub>x</sub> EMISSIONS

A discussion of uncontrolled NO<sub>x</sub> emissions from process heaters used in the petroleum refining and chemical industries is presented in this chapter. Thermal, fuel, and prompt NO<sub>x</sub> formation mechanisms are described in Section 4.1. A discussion of the factors that affect uncontrolled NO<sub>x</sub> emissions is presented in Section 4.2. Uncontrolled NO<sub>x</sub> emission factors and model heaters are presented in Section 4.3. Finally, Section 4.4 lists the references cited in this chapter.

### 4.1 FORMATION OF NO<sub>x</sub>

Seven oxides of nitrogen are known to occur naturally. Only two, NO and NO<sub>2</sub>, are considered important in atmospheric pollution. In this document, NO and NO<sub>2</sub> are referred to as "NO<sub>x</sub>." This section presents a discussion of NO<sub>x</sub> formation mechanisms that result from fuel combustion. Thermal, fuel, and prompt NO<sub>x</sub> formation mechanisms are described in Sections 4.1.1, 4.1.2, and 4.1.3, respectively.

#### 4.1.1 Thermal NO<sub>x</sub> Formation

Thermal NO<sub>x</sub> results from the thermal fixation of molecular nitrogen and oxygen present in the combustion air. The rate of thermal fixation increases rapidly at temperatures exceeding 1540°C (2800°F) and is more sensitive to local flame temperatures than oxygen concentrations.<sup>1</sup> Formation of thermal NO<sub>x</sub> is greatest in regions where the highest local flame temperatures occur.<sup>2</sup> The thermal NO<sub>x</sub> formation mechanism is commonly described using the Zeldovich mechanism, which is described by the following simplified reactions:<sup>3</sup>



Reaction 1 has a high activation energy, indicating the high temperatures necessary for  $\text{NO}_x$  formation.<sup>4</sup> At high combustion temperatures, dissociation of molecular oxygen occurs, allowing Reaction 1 to proceed. Reaction 1 describes molecular nitrogen combining with atomic oxygen to produce NO and is much slower than Reaction 2, which describes the combination of atomic nitrogen with molecular oxygen. Therefore, Reaction 1 controls the rate of formation of NO. The formation of an NO molecule from Reaction 1 results in the release of an N atom, which rapidly forms another NO molecule by the process described in Reaction 2.<sup>5</sup>

The rate of thermal  $\text{NO}_x$  formation is also described by the Zeldovich mechanism in the following simplified equation:<sup>1,2</sup>

$$[\text{NO}] = k_1 \exp(-k_2/T) [\text{N}_2] [\text{O}_2]^{1/2} t$$

where:

[ ] = mole fraction;

$k_1, k_2$  = constants;

T = peak flame temperature ( $^{\circ}\text{K}$ ); and

t = residence time of reactants at peak flame temperature.

The equation shows that the formation rate of thermal  $\text{NO}_x$  increases exponentially with increasing flame temperature and is also directly proportional to residence time in the peak flame zone. The key parameters of thermal  $\text{NO}_x$  formation are defined by this equation as temperature, oxygen and nitrogen concentrations, and residence time in the flame zone.<sup>1</sup> Variables that affect these three parameters are discussed in Section 4.2. Figure 4-1 shows the sensitivity of  $\text{NO}_x$  formation to temperature. Note that for an increase in temperature of less than  $55^{\circ}\text{C}$  ( $130^{\circ}\text{F}$ ), the concentration of  $\text{NO}_x$  increases by one order of magnitude.<sup>4</sup>



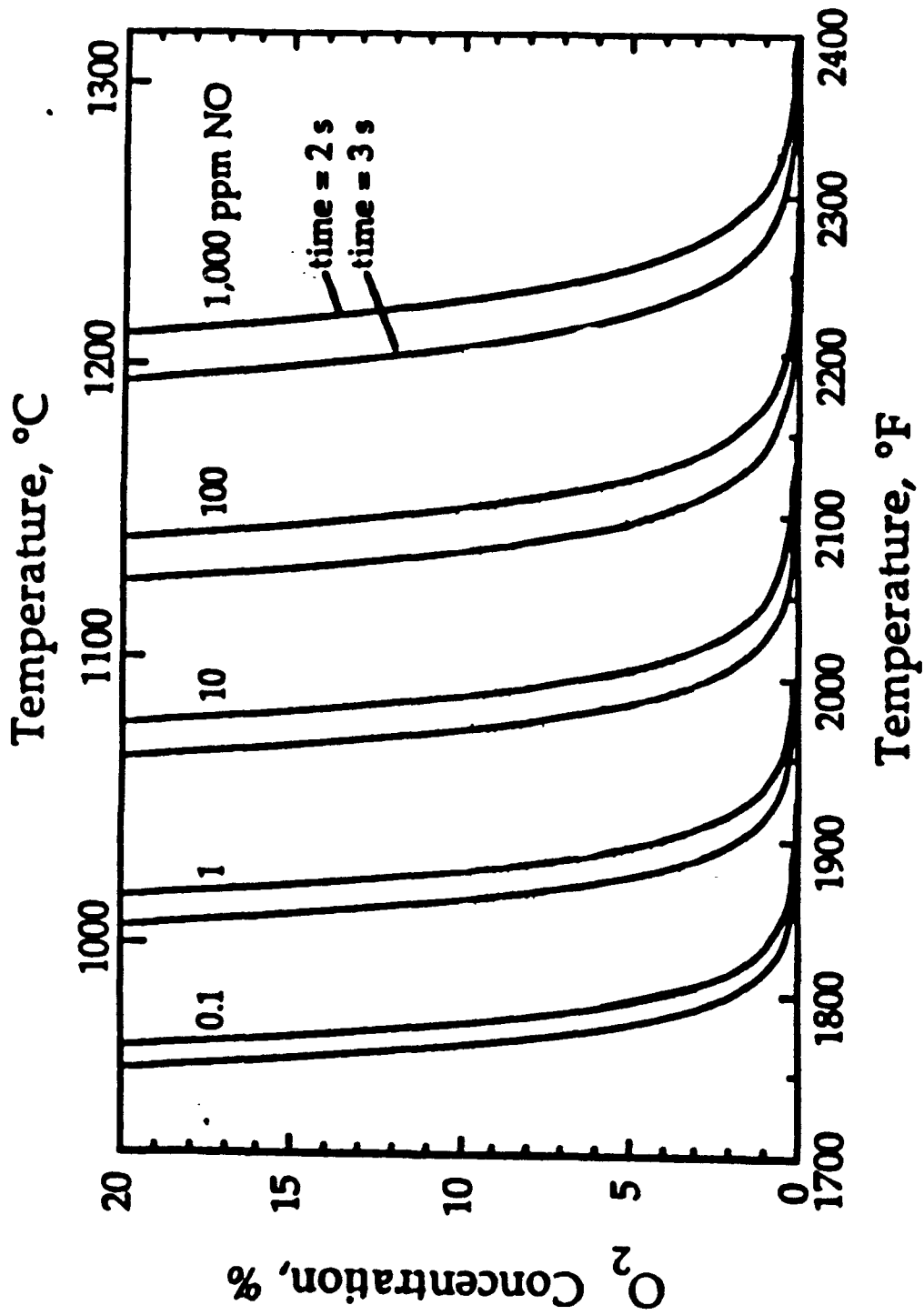

Figure 4-1. Impact of temperature on NO<sub>x</sub> formation.<sup>4</sup>

#### 4.1.2 Fuel NO<sub>x</sub> Formation

The role of fuel-bound nitrogen as a source of NO<sub>x</sub> emissions from combustion sources was recognized in 1968. Fuel NO<sub>x</sub> is the result of the reactions between fuel-bound nitrogen and oxygen in the combustion air. The bond in liquid and solid fuels between individual nitrogen atoms and other atoms, such as carbon, is not as strong as the N = N bond found in molecular nitrogen. In the combustion process, organically bound nitrogen atoms contained in the fuel are released and are rapidly oxidized to NO.<sup>5</sup>

The mechanisms by which chemically bound fuel nitrogen compounds are converted to NO<sub>x</sub> emissions are not yet fully understood.<sup>6</sup> Several studies, however, indicate that two separate mechanisms exist by which fuel-bound nitrogen compounds react to form NO<sub>x</sub>. The first, involving volatiles from solid or liquid fuels, is a gas-phase reaction. The second, involving solid fuels, is a solid-phase char reaction.<sup>7</sup>

Intermediate species, such as HCN, HOCN, and NH<sub>2</sub>, are postulated to be involved in gas-phase reactions. Gas-phase reactions are strongly dependent on the stoichiometry and weakly dependent on the local flame temperature.<sup>7</sup>

Char nitrogen reactions appear to depend more on flame temperature and less on stoichiometry. The physical and chemical characteristics of the char also influence the reaction rate.<sup>7</sup> The available data indicate that the conversion of fuel-bound nitrogen to NO<sub>x</sub> emissions ranges from 15 to 100 percent. Typically, fuels with relatively low nitrogen contents have higher nitrogen to NO<sub>x</sub> conversion rates than fuels with high nitrogen content, such as residual oils. However, the total quantity of nitrogen conversion is greater with high-nitrogen-content fuels, although the conversion percentage is lower. For example, 20 percent conversion of the nitrogen in a fuel with a nitrogen content of 1 percent by weight yields a greater quantity of NO<sub>x</sub> than 80 percent conversion of the nitrogen in a fuel with a nitrogen content of 0.1 percent by weight. Figure 4-2 shows the increase in NO<sub>x</sub> emissions due to the increase in nitrogen content of the fuel.<sup>1</sup>

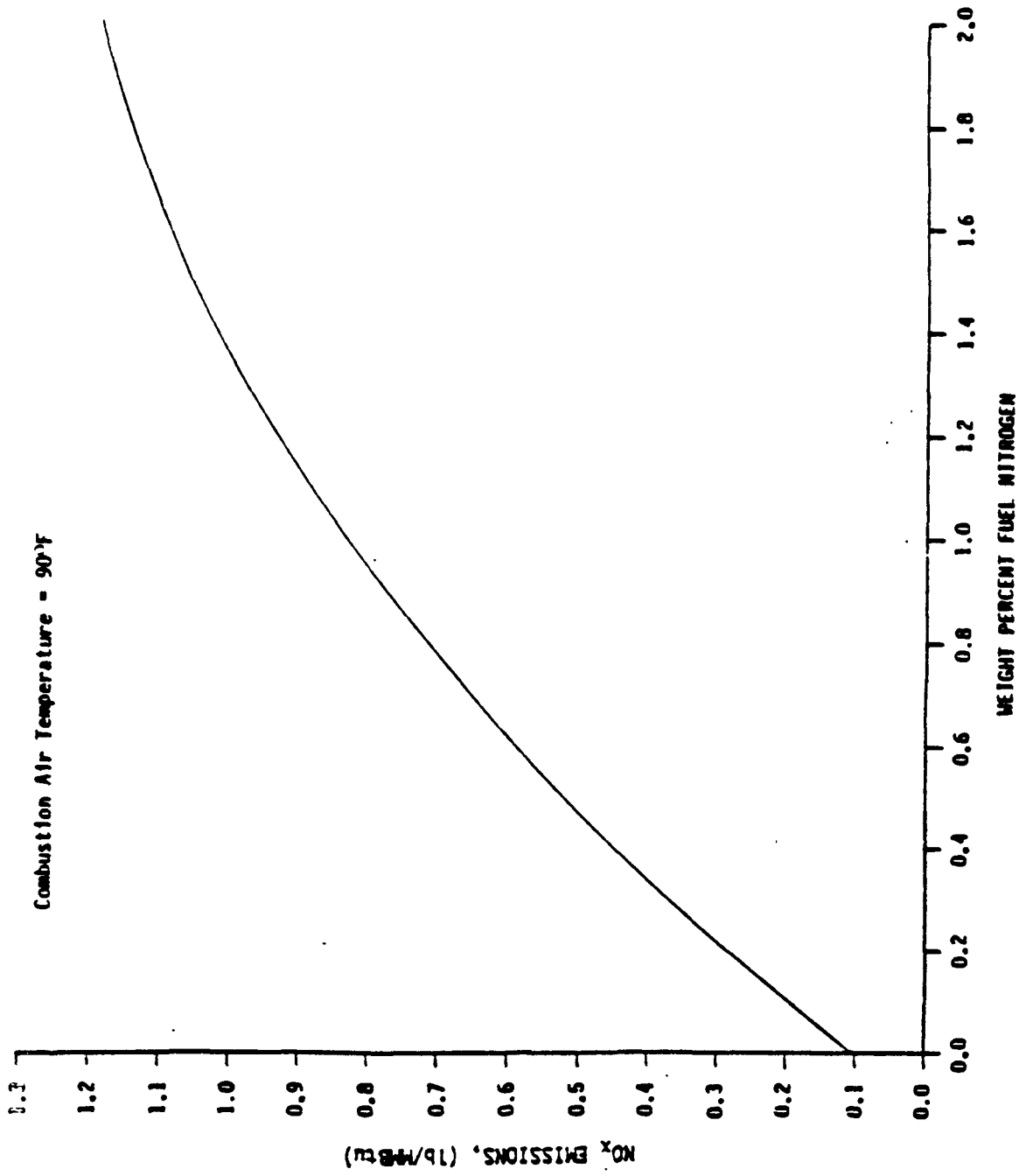

Figure 4-2. Effect of fuel-bound nitrogen on NO<sub>x</sub> emissions.<sup>1</sup>

#### 4.1.3 Prompt NO<sub>x</sub> Formation

Prompt NO<sub>x</sub> is a newly recognized mechanism of NO<sub>x</sub> formation. Prompt NO<sub>x</sub> formation increases in rich combustion conditions when fuels containing nitrogen are burned. Formation depends not on the fuel-bound nitrogen content but instead on the condition of the flame and tends to occur in rich zones in the flame front.<sup>7</sup> Prompt NO<sub>x</sub> formation becomes an important consideration when emission levels are 20 to 30 ppmv or below. Oxygen availability is another important factor; high levels of excess air can reduce prompt NO<sub>x</sub> formation. However, high excess air levels can also reduce fuel efficiency.<sup>8</sup>

Similar to gas-phase fuel NO<sub>x</sub> formation, prompt NO<sub>x</sub> is formed from products of intermediate reactions. The following equations describe intermediate reactions and the oxidation of the products:

1.  $\text{CH} + \text{N}_2 \rightarrow \text{HCN} + \text{N};$
2.  $\text{CH}_2 + \text{N}_2 \rightarrow \text{HCN} + \text{NH};$
3.  $\text{HCN} + \text{O}_x \rightarrow \text{NO} + \dots;$
4.  $\text{N} + \text{O}_x \rightarrow \text{NO} + \dots;$  and
5.  $\text{NH} + \text{O}_x \rightarrow \text{NO} + \dots .$

where O<sub>x</sub> indicates oxides such as O or O<sub>2</sub>.<sup>9,10</sup>

#### 4.2 FACTORS AFFECTING UNCONTROLLED NO<sub>x</sub> EMISSIONS

Many factors affect the level of uncontrolled NO<sub>x</sub> emissions from process heaters. Those factors can be categorized broadly under two headings: heater design parameters and heater operation parameters. Section 4.2.1 describes the heater design parameters that affect uncontrolled NO<sub>x</sub> emissions. Section 4.2.2 describes heater operation parameters that affect uncontrolled NO<sub>x</sub> emissions.

##### 4.2.1 Heater Design Parameters

Heater design parameters that affect the level of uncontrolled NO<sub>x</sub> emissions from process heaters include the

following: (1) fuel type, (2) burner type, (3) combustion air preheat, (4) firebox temperature, and (5) draft type.<sup>11</sup>

4.2.1.1 Fuel Type. Typically, process heaters burn liquid or gaseous fossil fuels. Liquid fuels burned include liquid butanes and pentanes, light fuel oils such as diesel and No. 2 distillate oil, and heavy fuel oils such as No. 6 residual oil. Gas fuels, such as hydrogen, methane, ethane, propane, and butane, are burned individually or in a variety of blends.<sup>12</sup> Natural gas and refinery fuel gas consist primarily of methane and are common fuels for process heaters. Any number of the previously mentioned gas fuels makes up the balance of components in natural and refinery fuel gas.

Research indicates that combustion of low-nitrogen distillate oil produces uncontrolled NO<sub>x</sub> emissions higher than does the combustion of natural gas at identical conditions of heat release rate, excess air, and combustion air preheat.<sup>11</sup> Although some refinery gases may have trace amounts of HCN, NH<sub>3</sub>, or other nitrogen-bearing species that may be oxidized to NO<sub>x</sub>, natural gas and refinery gas usually do not contain chemically bound nitrogen. Therefore, process heaters burning oil can be expected to produce higher NO<sub>x</sub> emissions per unit of energy absorbed than do comparable heaters burning natural gas, due to higher combustion temperatures and the greater formation of fuel NO<sub>x</sub>, which accompanies the combustion of fuel oils.<sup>11</sup>

Fuel NO<sub>x</sub> formation represents a greater fraction of the total NO<sub>x</sub> when high-nitrogen fuels such as residual oil are combusted. Therefore, fuel type has a large effect on the magnitude of NO<sub>x</sub> emissions from a combustion source.<sup>1</sup>

When refinery gas is fired, variations in hydrogen content can cause changes in the combustion characteristics of the fuel. The hydrogen content of refinery fuel gas fired in low- and medium-temperature process heaters can vary from 0 to 50 percent. This variation in hydrogen content results in heating values ranging from  $2.6 \times 10^7$  to  $8.2 \times 10^7$  Joules per cubic meter (J/m<sup>3</sup>) (700 to 2,200 British thermal units per standard cubic feet [Btu/scf]). High hydrogen fuel gas, which contains up to

80 percent hydrogen; is primarily fired in high-temperature heaters such as pyrolysis furnaces. High hydrogen fuel gas containing 50 to 80 mole percent hydrogen can have heating values ranging from  $1.48 \times 10^7$  to  $2.22 \times 10^7$  J/m<sup>3</sup> (400 to 600 Btu/scf). These variations in hydrogen content cause changes in flame temperature, propagation, and flame volume. Increased hydrogen content of the fuel produces a hotter flame, resulting in greater thermal NO<sub>x</sub> formation. One source reports that for a heater fired with fuel gas containing 50 percent or more hydrogen, NO<sub>x</sub> emissions can increase 20 to 50 percent over the same heater fired with natural gas.<sup>13</sup>

The proportions of oil and gas burned in a dual-fuel process heater affect NO<sub>x</sub> emissions. As stated earlier, under the same conditions, burners firing low-nitrogen distillate oil generate higher NO<sub>x</sub> emissions than do similar burners firing natural gas. Consequently, NO<sub>x</sub> emissions from oil/gas-fired heaters vary depending on the amount and type of oil that is mixed with the gas because NO<sub>x</sub> emissions increase with increasing oil content.<sup>14</sup>

4.2.1.2 Burner Type. The type of burner used in a process heater also has an impact on NO<sub>x</sub> emissions. The functions of a burner are to ensure (1) proper mixing of combustion reactants, (2) a continuous supply of combustion reactants, and (3) proper heat dispersion by regulating the size and shape of the flame envelope.<sup>15</sup> Because NO<sub>x</sub> formation is affected by the flame temperature, mixing of the reactants, and the residence time of the reactants at the peak flame temperature, burner design clearly affects the level of uncontrolled NO<sub>x</sub> emissions.

Burners are designed to fire specific fuels, and the fuel type greatly affects the magnitude of NO<sub>x</sub> emissions from a combustion source. Oil-fired heaters generate higher NO<sub>x</sub> emissions per unit of energy input than do comparable gas-fired heaters.<sup>11</sup> Most fired heaters, until recently, have used burners capable of firing oil or gas.<sup>11</sup> However, the current trend is to use gas-only burners to reduce the initial investment.<sup>16</sup>

Burners can be divided into conventional and low-NO<sub>x</sub> burners. Conventional burners are designed for high combustion

efficiency and low hydrocarbon (HC) and carbon monoxide (CO) emissions. Low-NO<sub>x</sub> burners are designed for low-NO<sub>x</sub> operation, while maintaining low HC and CO emissions and high fuel efficiency.

Conventional gas-fired burners are divided into three categories: raw gas burners, premix burners, and high-intensity burners. Raw gas burners receive fuel gas from the gas manifold without any premixing of combustion air. Premix burners receive a mixture of combustion air and fuel at the burner tip. High-intensity gas-fired burners are usually designed to fire low-Btu fuel gas that is unsuitable for low- and medium-temperature conventional burners. High-intensity burners are characterized by extremely compact flames and low-excess-air operation.<sup>17</sup>

Gas burners designed for low-NO<sub>x</sub> operation usually use staging techniques to reduce NO<sub>x</sub> emissions and are divided into two categories: staged-air burners and staged-fuel burners. Staged-air, gas-fired burners divide the combustion zone into two stages. The burner bypasses a fraction of the combustion air around the primary combustion zone and supplies it to the secondary combustion zone. The primary zone is operated under rich combustion conditions, and the secondary combustion zone is operated under lean combustion conditions. The primary zone creates a reducing environment, which inhibits fuel-NO<sub>x</sub> formation. The combustion reaction is cooled in the secondary zone by the secondary air, which inhibits thermal-NO<sub>x</sub> formation.

Staged-air, gas-fired burners may also supply tertiary air around the outside of the secondary combustion zone, which ensures complete combustion at relatively low combustion temperatures. Staged-fuel, gas-fired burners divide the combustion zone into two stages. The burner bypasses a fraction of the fuel around the primary combustion zone and supplies it to the secondary combustion zone. The primary zone is operated under lean combustion conditions, and the secondary zone is operated under rich conditions. The lean primary zone has a relatively cool combustion temperature, which inhibits thermal

NO<sub>x</sub> formation. Limited oxygen availability in the rich secondary zone further inhibits NO<sub>x</sub> formation.<sup>14</sup>

A relatively new type of premix burner uses a porous surface of ceramic or metallic fibers to burn gas fuels. These burners require forced draft combustion air supply. The combustion reactions are located on the outer surface of radiant burners. The outer surface of the burners glows uniformly instead of the flame extending outward from the burner tip, as in nonradiant burners. Flame stability and the absence of flame impingement are two operational advantages. Combustion occurs at approximately 1000°C (1830°F), which yields low NO<sub>x</sub> formation while producing low CO and HC emissions.<sup>18</sup>

There are two categories of oil burners: conventional oil burners and staged-air, oil-fired burners. Conventional oil burners have a single combustion zone, while staged-air oil-fired burners have at least two combustion zones.<sup>9</sup> The staged-air, oil-fired burners are designed to achieve lower NO<sub>x</sub> emissions than the conventional burners and operate similarly to the staged-air gas-fired burners.<sup>19</sup>

4.2.1.3 Combustion Air Preheat. A fuel-efficient process heater design is a priority consideration for heater users. Combustion air preheat is an effective method of reducing fuel consumption. However, preheating the combustion air increases the flame temperature of the burner, which results in greater NO<sub>x</sub> formation (Section 4.1.1).<sup>9</sup> Tests show that the higher the temperature of air preheat, the greater the formation of NO<sub>x</sub>. Figure 4-3 shows the effect of combustion air preheat on NO<sub>x</sub> emissions from a test-scale, mechanical draft (MD) heater.<sup>15</sup> Preheating the combustion air temperature from ambient (21°C [70°F]) to 204°C (400°F) increases NO<sub>x</sub> emissions by a factor of 1.4 and more than doubles emissions when the air is preheated to 316°C (600°F).<sup>13</sup>

4.2.1.4 Firebox Temperature. As discussed in Section 4.1.1, the rate of formation of thermal NO<sub>x</sub> increases exponentially with increasing flame temperature. The flame temperature is directly related to the firebox temperature, which



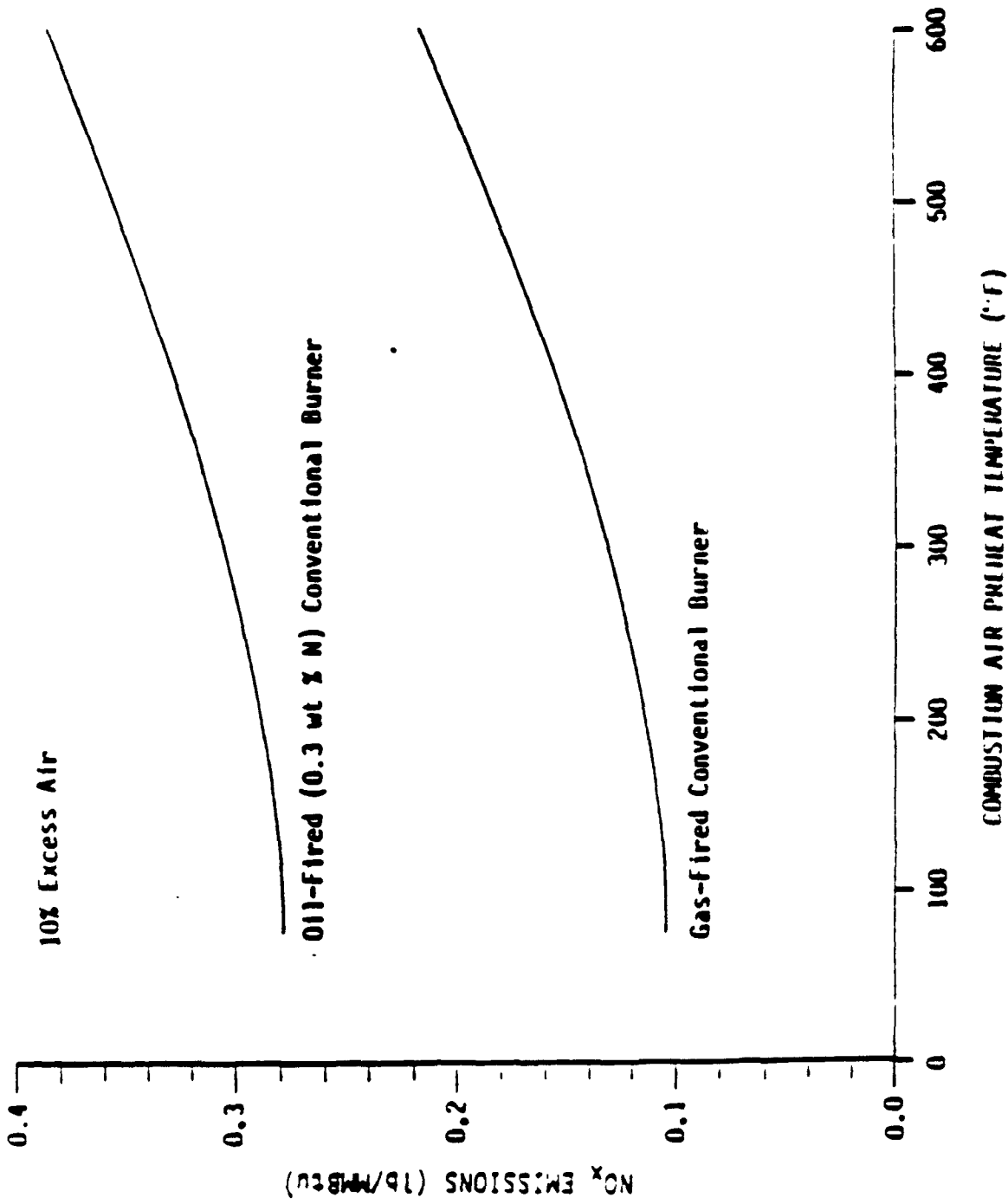

Figure 4-3. Effect of combustion air preheat temperature on NO<sub>x</sub> emissions. 15

is determined by the process requirements.<sup>9</sup> Therefore, applications requiring high firebox temperatures, such as steam hydrocarbon reformers and olefins pyrolysis furnaces, will likely have higher NO<sub>x</sub> emissions than applications using medium and low firebox temperatures.<sup>9</sup> In general, heaters with high volumetric heat release rates have high flame and firebox temperatures. Figure 4-4 shows the relationship between firebox temperature and thermal NO<sub>x</sub> formation. This figure shows that for gas-fired heaters, thermal NO<sub>x</sub> emissions increase by a factor of about 1.5 when the firebox temperature is increased from 700°C (1300°F) to 1040°C (1900°F).<sup>15</sup> One source reports that below 1100°C (2100°F) thermal NO<sub>x</sub> increases a nominal 10 percent for every 40°C (100°F) increase in firebox temperature, which is consistent with the above data.<sup>16</sup> The same source reports that increasing the temperature from 700° to 1000°C (1300° to 1900°F) can increase thermal NO<sub>x</sub> formation by as much as a factor of 4 in some process heaters. However, recent information indicates the rate of thermal NO<sub>x</sub> formation at temperatures above 930°C (1700°F) continues to increase, contrary to the trend shown by the curve.<sup>20</sup> The effect of increased firebox temperature on fuel NO<sub>x</sub> from oil-fired heaters is expected to be less than that described above for gas-fired heaters because, fuel NO<sub>x</sub> formation is less sensitive to temperature than thermal NO<sub>x</sub> formation.<sup>9</sup>

4.2.1.5 Draft Type. As discussed in Section 3.1.3.2, the two basic methods for combustion air supply for process heaters are natural draft (ND) and MD. These MD systems can be further divided into three categories: forced draft, induced draft, and balanced draft. The three types are distinguished by the position of the fan(s) relative to the heater unit. The fan is located upstream of the firebox in the forced draft heater and downstream of the firebox in the induced draft heater. Balanced draft heaters use both forced and induced draft fans to control the combustion airflow. Balanced draft is more often used for boilers than for process heaters. Boilers may operate with radiant firebox pressures of  $\pm 20$  inches of water (in. H<sub>2</sub>O), but process heaters operate with radiant firebox pressures slightly

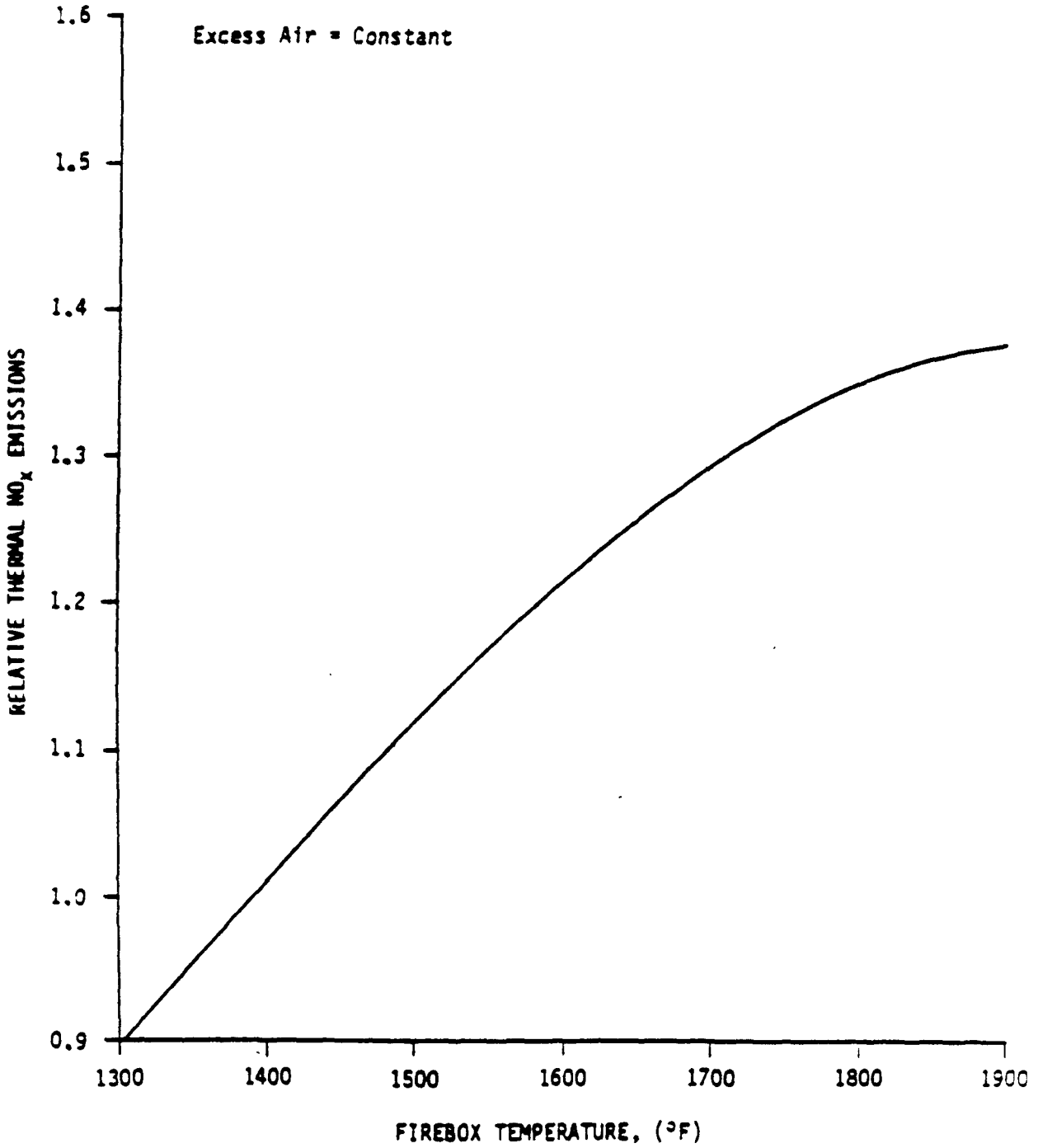

Figure 4-4. Effect of firebox temperature on thermal NO<sub>x</sub> formation for gas-fired heaters with constant excess air.<sup>11</sup>

below ambient pressure. Process heater construction does not tolerate large variations in firebox pressures like those in boilers.<sup>16</sup> In ND heaters, the pressure difference between the hot gases in the stack and the cooler air outside results in a "draft," which causes the combustion air to flow into the burners. Draft type can influence uncontrolled NO<sub>x</sub> emissions by affecting the level of excess air in the combustion zone. Additionally, NO<sub>x</sub> emissions can be lowered by converting the heater to forced draft and operating with lower excess air and improved flame shape.<sup>21</sup>

#### 4.2.2 Heater Operating Parameters

This section describes the operating parameters that, in addition to the design parameters, affect the level of uncontrolled NO<sub>x</sub> emissions from process heaters. These operating parameters include (1) excess air, (2) volumetric heat release, and (3) burner adjustments.<sup>12-14</sup>

4.2.2.1 Excess Air. Excess air is required to ensure complete combustion of fuel in the burner. Optimum fuel efficiency and low HC, CO, and NO<sub>x</sub> emissions can be achieved only over a small range of excess air levels. A typical excess air level for a process heater is approximately 15 percent. The amount of excess air present depends on a variety of factors including fuel type, draft type, burner design, and air leaks.<sup>1,14</sup> The excess air level should be measured at the burner or in the radiant zone because air leakage above the radiant section may indicate higher excess air levels in the stack than exist in the burner combustion zone.<sup>16</sup> The term "excess oxygen" is sometimes used instead of "excess air." Three percent excess oxygen corresponds to approximately 15 percent excess air.<sup>16</sup>

A statistical analysis of long-term continuous emissions data on gas-fired heaters at petroleum refineries showed that NO<sub>x</sub> emissions typically increase about 9 percent for each 1 percent increase in the measured stack oxygen level. The data base for this analysis includes a range of 540 to 3,400 hourly NO<sub>x</sub> emission data points for each heater.<sup>14</sup> The effect of excess air on NO<sub>x</sub> formation in gas-fired heaters using these data is shown

in Figure 4-5. Another source reports a NO<sub>x</sub> emissions increase of 6 percent for every 1 percent increase in excess oxygen.<sup>16</sup> Increasing the excess air will result in greater NO<sub>x</sub> emissions until the oxygen content of the flue gas reaches approximately 6 percent, at which point NO<sub>x</sub> formation begins to decrease. This decrease can be attributed to the flame cooling effect of the excess air, which reduces the formation of thermal NO<sub>x</sub>.<sup>2</sup> One source indicates that increased fuel firing is generally required when excess oxygen levels are above 6 percent as a result of decreased fuel efficiency.<sup>16</sup> However, radiant burners are reported to be capable of minimizing HC, CO, and NO<sub>x</sub> emissions without sacrificing fuel efficiency, even with excess air levels of 10 to 20 percent.<sup>8</sup>

4.2.2.2 Burner Adjustments. Burner adjustments can affect NO<sub>x</sub> emissions by altering the flame characteristics. By adjusting the burner to increase flame length, the peak flame temperature is decreased, thereby decreasing NO<sub>x</sub> formation.<sup>13</sup> Some heaters require a more uniform heat flux produced by well-defined, compact flames. This type of high-intensity flame produces higher NO<sub>x</sub> levels than the long, low-intensity flame.<sup>12,13</sup>

For heaters equipped with staged-air burners, the relative amount of air introduced into the primary and secondary burner combustion zones can have a large effect on NO<sub>x</sub> emissions. Tests indicate that combustion air distribution can be adjusted to minimize NO<sub>x</sub> emissions from the heater.<sup>13</sup> However, burner adjustments or settings are generally dictated by process requirements and may not coincide with optimum NO<sub>x</sub> control.<sup>16</sup>

#### 4.3 UNCONTROLLED NO<sub>x</sub> EMISSION FACTORS AND MODEL HEATERS

Uncontrolled NO<sub>x</sub> emission rates were available from several sources. These sources include AP-42 (Compilation of Air Pollutant Emission Factors, fourth edition, October 1986), American Petroleum Institute (API) publications, and an emission inventory from process heater installations. Several factors affect the uncontrolled emission rates, as mentioned in Section 4.2. The NO<sub>x</sub> emission factors predicted by these publications

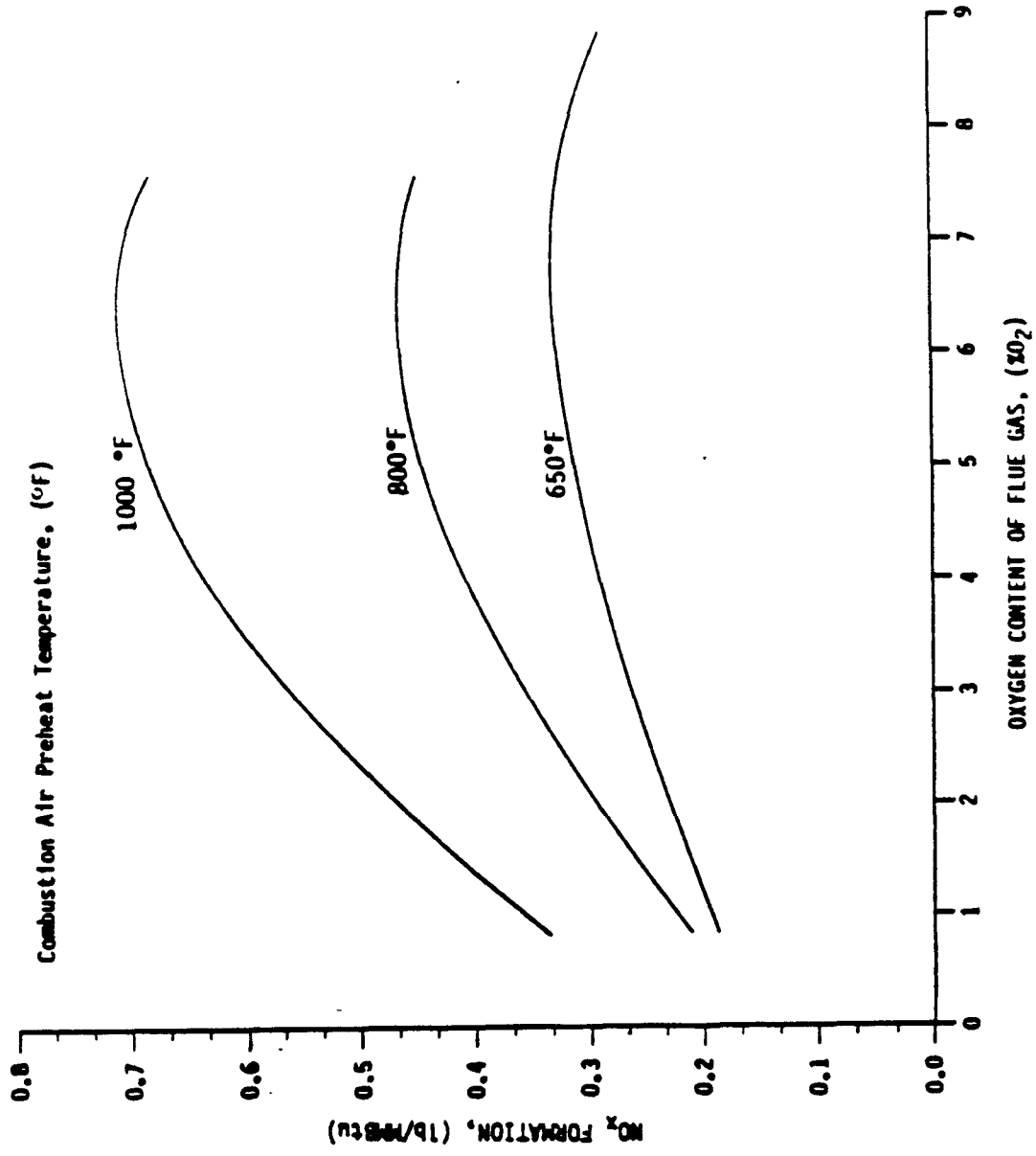

Figure 4-5. Effect of excess air on NO<sub>x</sub> formation in gas-fired process heaters at various combustion air preheat temperatures.

vary as a result of these factors. Because of the variability in published uncontrolled  $\text{NO}_x$  emission factors, a model heater approach is used in this chapter in order to compare the uncontrolled  $\text{NO}_x$  emissions for the different types of heaters. These same model heaters are also used in Chapters 5 and 6 in order to evaluate the  $\text{NO}_x$  emission control techniques and the cost effectiveness of available  $\text{NO}_x$  emission control techniques. Uncontrolled  $\text{NO}_x$  emission factors are presented in Section 4.3.1. The model heaters and corresponding uncontrolled emission factors are presented in Section 4.3.2.

#### 4.3.1 Uncontrolled $\text{NO}_x$ Emissions

AP-42 provides uncontrolled emission factors for process heaters and boilers classified by the heat input rate, using the higher heating value for the type of fuel burned.<sup>23</sup> These emission factors, shown in Table 4-1, are based on test data for boilers. Three ranges of heat rates were defined for gas-fired units, two ranges of heat rates were defined for distillate oil-fired units, and three ranges of heat rates were defined for residual oil-fired units. Uncontrolled  $\text{NO}_x$  emission factors were reported for each of the ranges of heat rates for each fuel.

Average emission factors for natural gas-, distillate oil-, and residual oil-fired operation for ND and MD refinery heaters were developed in a 1979 API-sponsored study.<sup>24</sup> Figure 4-6 presents uncontrolled  $\text{NO}_x$  emission factors versus heat input developed from API data. The burner configuration, draft type, and air preheat conditions were not reported for all of the process heaters in the test. Figure 4-7 shows the  $\text{NO}_x$  emission factors versus heat input for the gas-fired process heaters with known burner configuration, draft type, and preheat conditions. These figures illustrate that  $\text{NO}_x$  emissions are not related solely to heat input. In addition, the increased  $\text{NO}_x$  emissions resulting from using air preheaters by the majority of MD units is reflected in the relatively high emission factors for MD heaters shown in Figures 4-6 and 4-7.<sup>24</sup> The uncontrolled  $\text{NO}_x$  emissions for distillate and residual fuel oils increase with

TABLE 4-1. AP-42 ESTIMATES FOR UNCONTROLLED NO<sub>x</sub> EMISSIONS FROM BOILERS AND PROCESS HEATERS<sup>23</sup>

Heat rate, MMBtu/hr	Fuel	NO <sub>x</sub> emission factor	
		ng/J <sup>a</sup>	lb/MMBtu
<10	Natural gas	41	0.10
10-100	Natural gas	58	0.14
>100	Natural gas	228	0.53
<10	Distillate oil <sup>b</sup>	63	0.15
	Residual oil <sup>c</sup>	162	0.38
10-100	Distillate oil <sup>b</sup>	63	0.15
	Residual oil <sup>c</sup>	162	0.38
>100	Residual oil <sup>c</sup>	197	0.46

<sup>a</sup>ng/J = nanogram per Joule

<sup>b</sup>Distillate oils include Nos. 1 and 2 fuel oils.

<sup>c</sup>Residual oils include Nos. 4, 5, and 6 fuel oils.



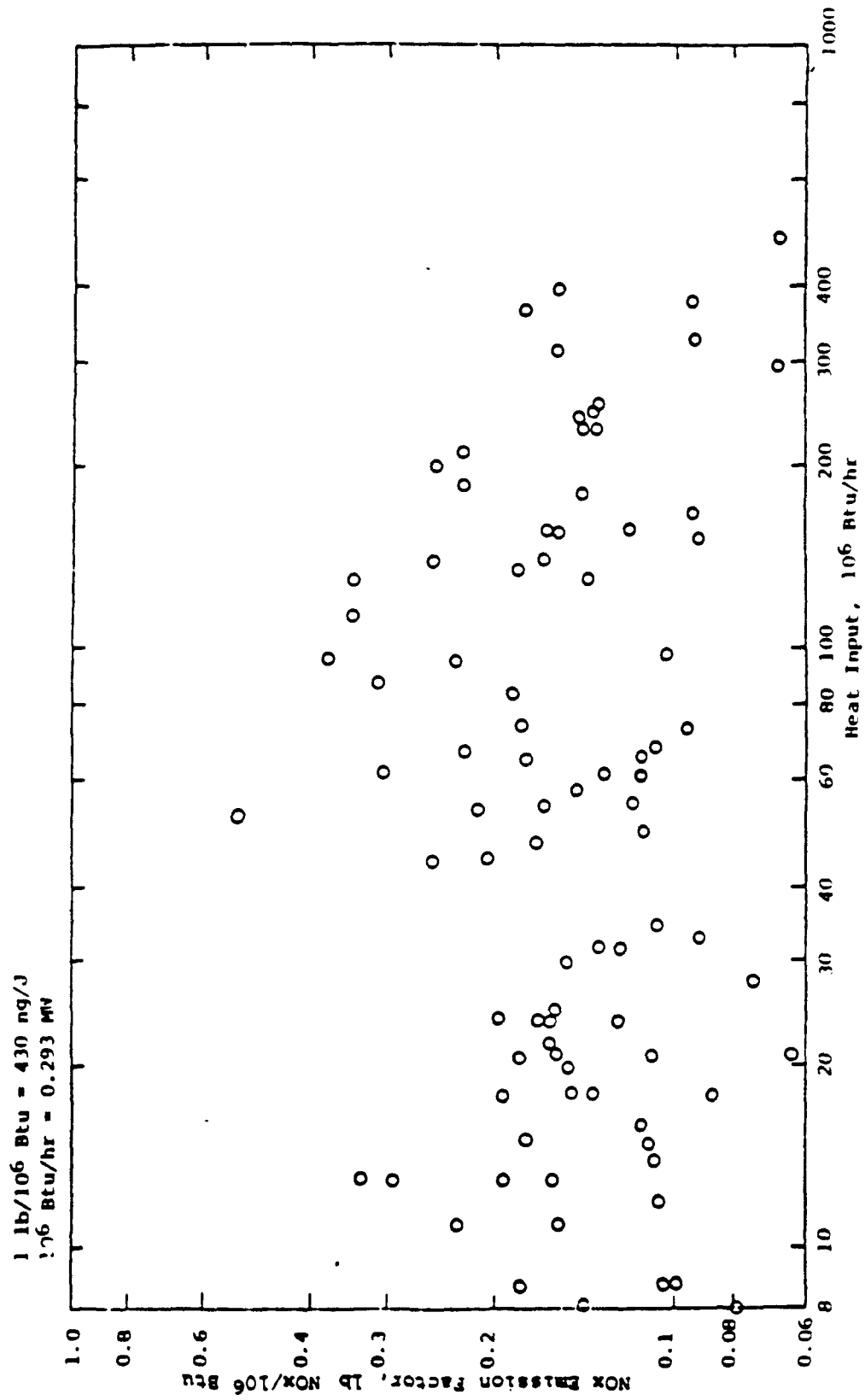

Figure 4-6. Uncontrolled NO<sub>x</sub> emission data versus heat input for gas-fired refinery process heaters of various design types.<sup>24</sup>

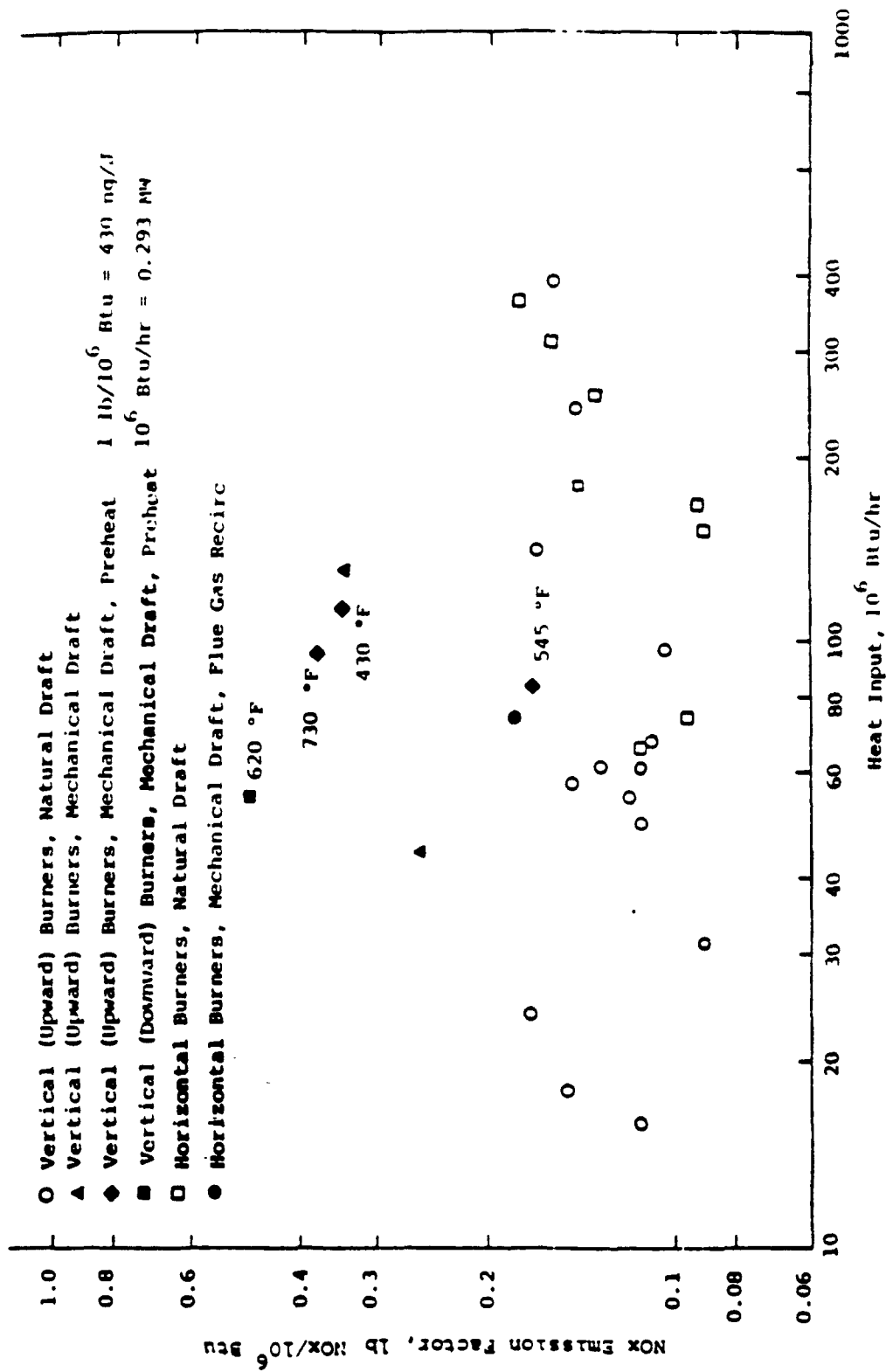

Figure 4-7. Uncontrolled  $\text{NO}_x$  emission factors for gas-fired refinery process heaters with known burner configuration, draft type, and air preheat conditions. <sup>24</sup>

increases in the nitrogen content of the fuel being burned as a result of the formation of fuel  $\text{NO}_x$ .

Uncontrolled  $\text{NO}_x$  emission factors developed by averaging the data shown in Figures 4-6 and 4-7 are presented in Table 4-2. The emission factors in Table 4-2 for residual and distillate oil were calculated from the emission factors for gas-firing with adjustments for fuel nitrogen content based on information from API Publication 4311. This table indicates that emissions are not directly related to heat rate. The uncontrolled emission factors in Table 4-2 are categorized by fuel and draft system. Uncontrolled emission factors were reported for gas-fired heaters using ND without preheat, gas-fired heaters using MD with preheat, distillate oil-fired heaters using ND without preheat, distillate oil-fired heaters using MD with preheat, residual oil-fired heaters using ND without preheat, residual oil-fired heaters using MD with preheat.<sup>24</sup> The emission factors increase with increasing fuel-bound nitrogen content. The emission factors for MD are higher than for ND because preheat was used in the majority of the MD heaters.

An emission inventory for gas-fired ND and MD process heaters at a refinery installation is presented in Figure 4-8.<sup>25</sup> This inventory, tabled in Appendix A, is considered to be representative of the heat rates and emission rates for process heaters installed in refinery and chemical manufacturing applications. The MD heaters use air preheat and Figure 4-8 shows  $\text{NO}_x$  emission rates are generally higher from MD heaters compared to ND heaters. For both ND and MD heaters, emission rates are largely insensitive to heater size. A summary of the emission rates for the refinery process heater inventory is shown in Table 4-3. The data presented in Table 4-3 are grouped by draft type, and the average emission rates include both natural gas- and refinery gas-fueled heaters. The average  $\text{NO}_x$  emission rate is 0.098 lb/MMBtu for ND heaters and 0.197 lb/MMBtu for MD heaters. As discussed in Section 4.2.1.1, heaters firing refinery fuel gas have higher  $\text{NO}_x$  emissions rates than natural gas-fueled heaters.

TABLE 4-2. AVERAGE UNCONTROLLED NO<sub>x</sub> EMISSIONS FROM REFINERY  
 PROCESS HEATERS BASED ON EMISSION DATA FROM API<sup>24</sup> (lb/MMBtu)

Fuel	Natural draft <sup>a</sup>	Mechanical draft <sup>b</sup>
Gaseous	0.14	0.26
Distillate oil <sup>c</sup>	0.20	0.32
Residual oil <sup>d</sup>	0.42	0.54

<sup>a</sup>Using ambient combustion air.

<sup>b</sup>Using air preheated to 200°C (390°F), on average.

<sup>c</sup>Fuel nitrogen content of 0.04 percent. Fuel NO<sub>x</sub> contributes 0.06 lb/MMBtu to total uncontrolled emissions.

<sup>d</sup>Fuel nitrogen content of 0.29 percent. Fuel NO<sub>x</sub> contributes 0.28 lb/MMBtu to total uncontrolled emissions.

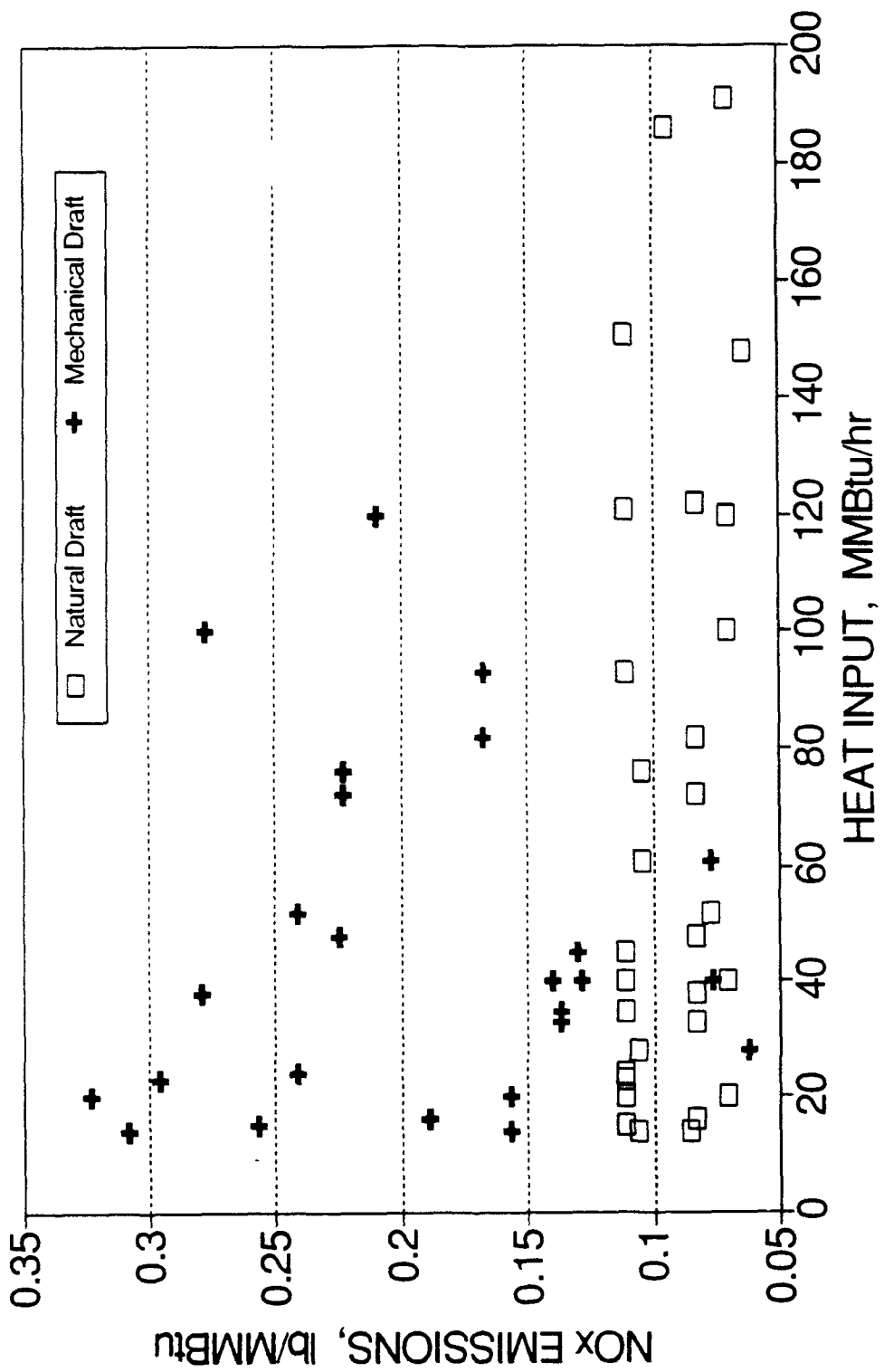

Figure 4-8. Uncontrolled NO<sub>x</sub> emission rates for gas-fired process heaters at one refinery installation.<sup>25</sup>

TABLE 4-3. AVERAGE UNCONTROLLED NO<sub>x</sub> EMISSIONS FROM PROCESS HEATERS AT ONE REFINERY INSTALLATION<sup>25</sup>

Fuel	NO <sub>x</sub> emissions, lb/MMBtu					
	Natural draft <sup>a</sup>			Mechanical draft <sup>b</sup>		
	No. of heaters	Range	Average	No. of heaters	Range	Average
Gaseous	32	.064 - .011	.098	26	.062 - .323	.197

<sup>a</sup>Using ambient combustion air.

<sup>b</sup>Using air preheated to 310°C (595°F), on average.

Pyrolysis furnaces, due to their high firebox temperatures and combustion intensity, have relatively high uncontrolled NO<sub>x</sub> emission rates. Two sources estimated from their operating experience that uncontrolled NO<sub>x</sub> emissions range from approximately 0.130 to 0.140 lb/MMBtu for natural gas-fired furnaces.<sup>26</sup> Limited data for natural gas-fired pyrolysis furnaces was consistent with this range. Pyrolysis furnaces are often fired with refinery gas, with hydrogen contents ranging to 50 mole percent or higher. According to one source, uncontrolled NO<sub>x</sub> levels may be 20 to 50 percent higher when burning high-hydrogen refinery gas fuel than the 0.130 to 0.140 lb/MMBtu range for natural gas.<sup>27</sup> A second source indicated that controlled burner tests showed increases in uncontrolled NO<sub>x</sub> emissions for high-hydrogen refinery gas fuel ranging from 15 to 20 percent over natural gas-fired emission levels.<sup>28</sup> These estimates indicate that uncontrolled NO<sub>x</sub> emission rates range from 0.150 to 0.210 lb/MMBtu for high-hydrogen content refinery gas firing; data were not available to verify this range.

#### 4.3.2 Model Heaters

Five categories of model heaters were developed in this study to represent process heaters that have similar uncontrolled NO<sub>x</sub> emissions in the refinery and chemical industry. These models were developed to take into account the variations in the sizes, fuels, and draft systems that affect NO<sub>x</sub> emissions. The five model heater categories are (1) natural gas-fired, low- and medium-temperature ND without preheat; (2) natural gas-fired, low- and medium-temperature MD with preheat; (3) oil-fired, low- and medium-temperature ND without preheat; (4) oil-fired, low- and medium temperature MD with preheat; and (5) ND without preheat olefins pyrolysis heaters.

The natural gas-fired ND and MD, low- and medium-temperature model heaters are based on the refinery process heater inventory shown in Figure 4-8. The ND without preheat, natural gas-fired, low- and medium-temperature model heaters are presented in Table 4-4. Figure 4-9 presents a graphical representation of the heat rates of the ND heaters in Figure 4-8. Several natural

TABLE 4-4. MODEL HEATERS AND UNCONTROLLED NO<sub>x</sub> EMISSION FACTORS:  
 NATURAL GAS-FIRED, LOW- AND MEDIUM-TEMPERATURE ND  
 WITHOUT PREHEAT<sup>25</sup>

Model heater capacity, MMBtu/hr	Size range, MMBtu/hr	No. of burners	Uncontrolled NO <sub>x</sub> emission factors, lb/MMBtu
17	$x \leq 20$	4	0.098
36	$20 < X \leq 50$	7	0.098
77	$50 < X \leq 100$	8	0.098
121	$100 < X \leq 150$	19	0.098
185	$150 < X$	29	0.098

TABLE 4-5. MODEL HEATERS AND UNCONTROLLED NO<sub>x</sub> EMISSION FACTORS:  
 NATURAL GAS-FIRED, LOW- AND MEDIUM-TEMPERATURE MD  
 WITH PREHEAT<sup>25</sup>

Model heater capacity, MMBtu/hr	Size range, MMBtu/hr	No. of burners	Uncontrolled NO <sub>x</sub> emission factors, lb/MMBtu
40	$x \leq 50$	6	0.197
77	$50 < x \leq 100$	16	0.197
114	$100 < X \leq 150$	34	0.197
174	$150 < X \leq 200$	31	0.197
263	$200 < X$	20	0.197



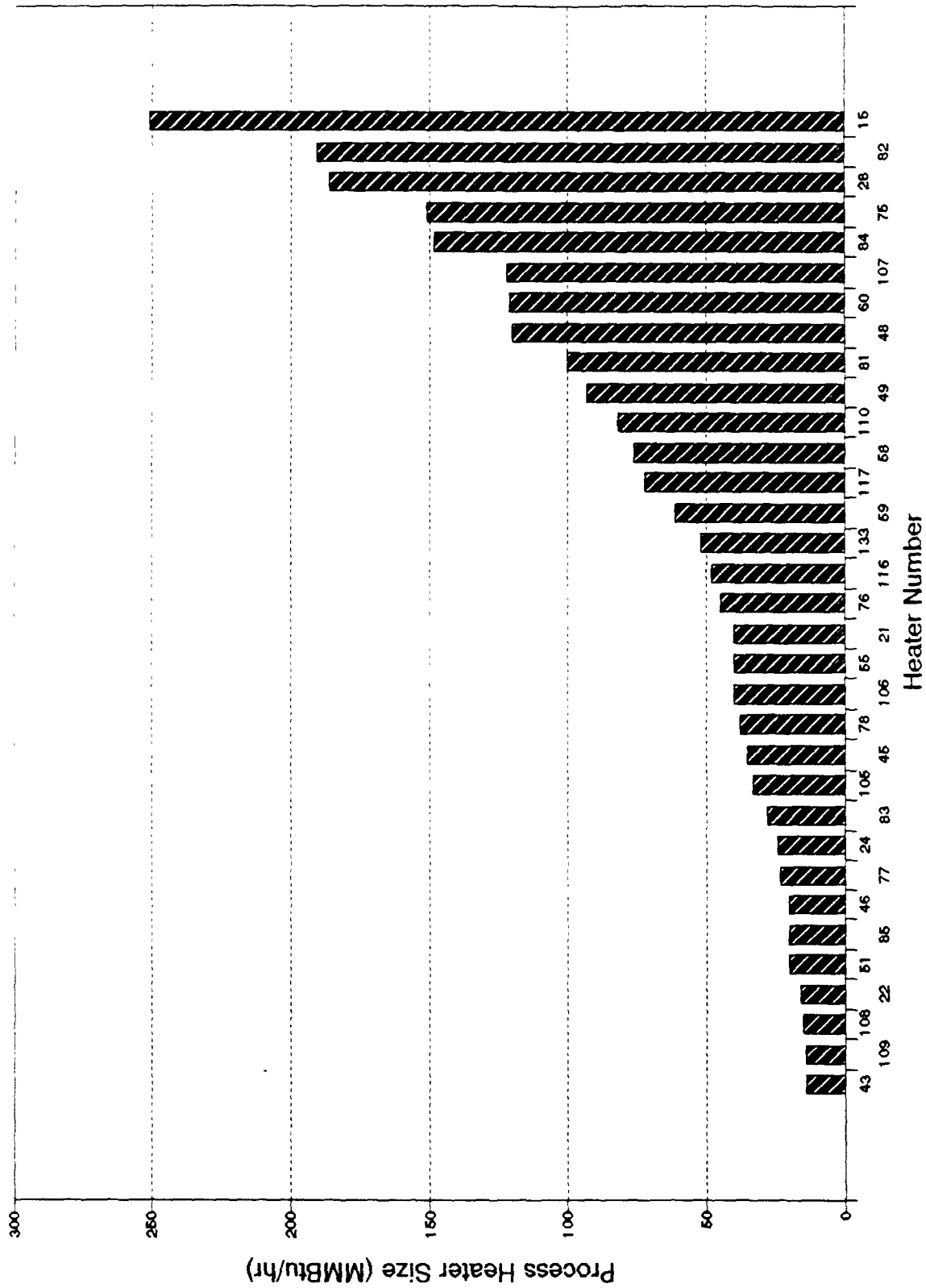

Figure 4-9. Natural draft process heater refinery inventory. 25

breaks tend to divide the heaters in Figure 4-9 into groups according to heat rate and, therefore, model heaters were developed to represent five heat rate ranges. Each model heater represents the average size heater for the specified range of heat rates. The heat rates of these five model heaters are 17, 36, 77, 121, and 185 MMBtu/hr. The uncontrolled emission factor based on natural gas-firing for these model heaters is 0.098 lb/MMBtu, which is the average of the uncontrolled emission factors for ND heaters as shown in Table 4-3. Typically, heaters in this category fire natural gas or refinery fuel gas with less than 50 mole percent hydrogen. As discussed in Section 4.2.1.1, heaters firing refinery fuel gas with up to 50 mole percent hydrogen can have up to 20 percent higher NO<sub>x</sub> emissions than the same heater firing natural gas.<sup>16</sup>

The MD with preheat, natural gas-fired, low- and medium-temperature model heaters are presented in Table 4-5. Figure 4-10 presents a graphical representation of the heat rates of the MD heaters in Figure 4-8. As is the case with ND heaters, several natural breaks tend to divide the heaters into groups according to heat rate and, therefore, five model heaters were developed to represent heat rate ranges. Each model heater represents the average size heater for the specified range of heat rates. The heat rates of these five model heaters are 40, 77, 114, 174, and 263 MMBtu/hr. The uncontrolled emission factor based on natural gas-firing for these model heaters is 0.197 lb/MMBtu, which is the average of the uncontrolled emission factors for MD heaters in Table 4-3. Typically, heaters in this category fire natural gas or refinery fuel gas with less than 50 mole percent hydrogen. As discussed in Section 4.2.1.1, heaters firing refinery fuel gas with up to 50 mole percent hydrogen can have up to 20 percent higher NO<sub>x</sub> emissions than the same heater firing natural gas.<sup>16</sup>

A total of four low- and medium-temperature oil-fired model heaters were developed. Two ND without preheat model heaters, one distillate and one residual oil-fired, are presented in Table 4-6. The capacity of each is 69 MMBtu/hr, which represents

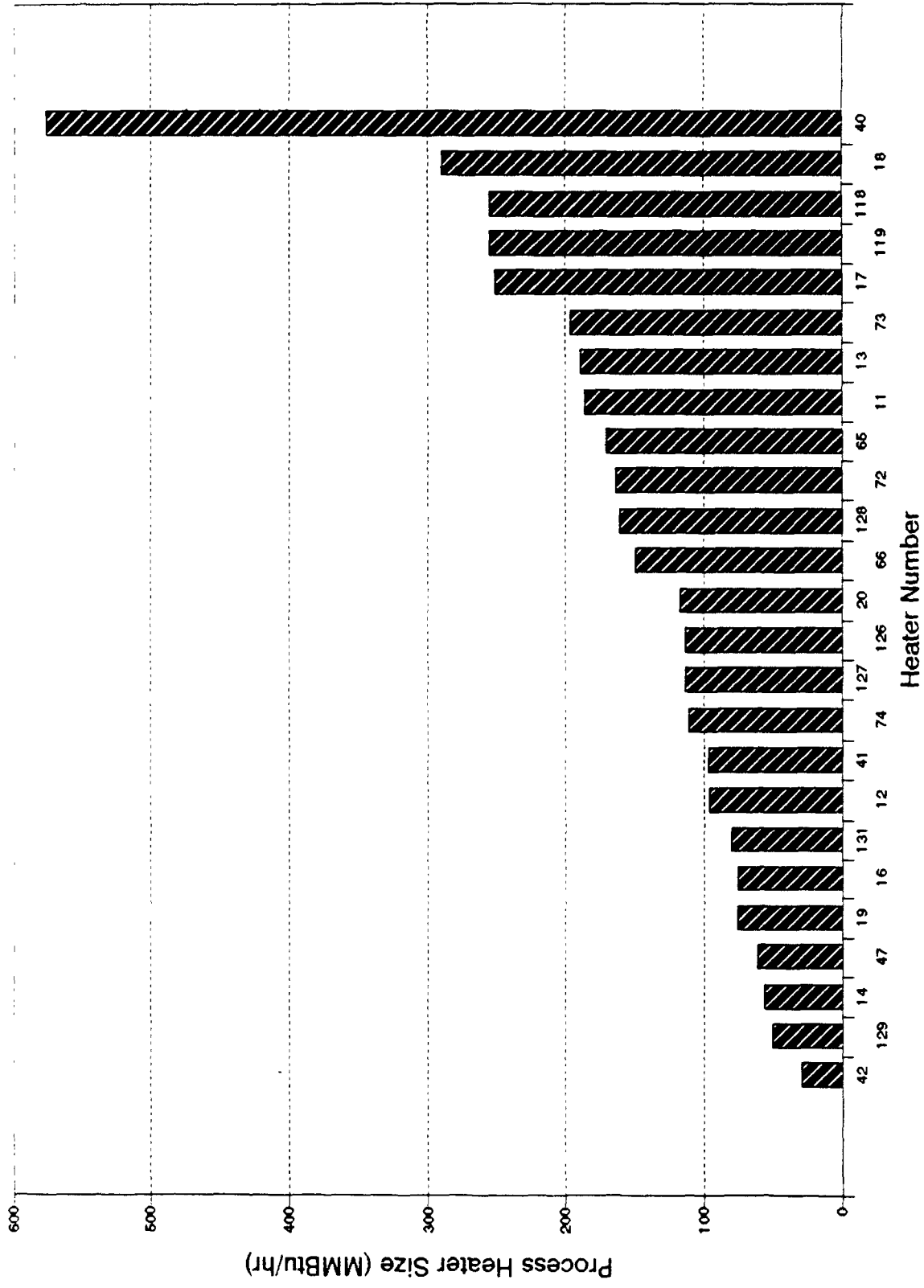

Figure 4-10. Mechanical draft process heater refinery inventory. 25

the average size of ND process heaters reported in an API study.<sup>24</sup> Two MD with preheat model heaters, one distillate and one residual oil-fired, are presented in Table 4-7. The capacity of each is 135 MMBtu/hr, which represents the average size of MD process heaters with preheat reported in the API study. The uncontrolled NO<sub>x</sub> emission factors for the oil-fired model heaters were developed using Table 4-2. A thermal NO<sub>x</sub> and a fuel NO<sub>x</sub> factor are presented in Tables 4-6 and 4-7 for each model heater and are not summed because each formation mechanism is treated differently when considering achievable NO<sub>x</sub> reductions for some control techniques. For the oil-fired ND without preheat heaters the uncontrolled thermal NO<sub>x</sub> emission factor is 0.140 lb/MMBtu for both distillate and residual oil firing. Fuel NO<sub>x</sub> factors were calculated as the difference between the uncontrolled NO<sub>x</sub> factors in Table 4-2 for gaseous and oil fuels, and are 0.060 and 0.280 lb/MMBtu for distillate and residual oil firing, respectively. For the oil-fired MD with preheat heaters the uncontrolled thermal NO<sub>x</sub> emission factor is 0.260 lb/MMBtu for both distillate and residual oil firing. Fuel NO<sub>x</sub> factors are 0.060 and 0.280 lb/MMBtu for distillate and residual oil firing, respectively.

Table 4-8 presents two model heaters representing olefins pyrolysis furnaces. The model pyrolysis heaters are an ND natural gas-fired heater and a ND high hydrogen gas-fired heater with a heat rate of 84 MMBtu/hr, without preheat. These models were developed based on information and limited data from natural gas-fired and high-hydrogen gas-fired pyrolysis furnace installations, which are discussed in Section 4.3.1. The uncontrolled NO<sub>x</sub> emission factor for the natural gas-fired model pyrolysis furnace is 0.135 lb/MMBtu, which is the average of the 0.130 to 0.140 lb/MMBtu range discussed in Section 4.3.1. The uncontrolled NO<sub>x</sub> emission factor for the high-hydrogen gas-fired pyrolysis model furnace is 0.162 lb/MMBtu, which is 20 percent higher than the natural gas-fired pyrolysis model furnace.

TABLE 4-6. MODEL HEATERS AND UNCONTROLLED EMISSION FACTORS: DISTILLATE AND RESIDUAL OIL-FIRED, LOW- AND MEDIUM-TEMPERATURE ND WITHOUT PREHEAT<sup>24</sup>

Model heater capacity, MMBtu/hr	Fuel	No. of burners	Uncontrolled NO <sub>x</sub> emission factor, lb/MMBtu	
			Thermal NO <sub>x</sub>	Fuel NO <sub>x</sub>
69	Distillate oil <sup>a</sup>	24	0.140	0.060
69	Residual oil <sup>b</sup>	24	0.140	0.280

<sup>a</sup>0.04 percent N

<sup>b</sup>0.29 percent N

TABLE 4-7. MODEL HEATERS AND UNCONTROLLED EMISSION FACTORS: DISTILLATE AND RESIDUAL OIL-FIRED, LOW- AND MEDIUM-TEMPERATURE MD WITH PREHEAT<sup>24</sup>

Model heater capacity, MMBtu/hr	Fuel	No. of burners	Uncontrolled NO <sub>x</sub> emission factor, lb/MMBtu	
			Thermal NO <sub>x</sub>	Fuel NO <sub>x</sub>
135	Distillate oil <sup>a</sup>	14	0.26	0.060
135	Residual oil <sup>b</sup>	14	0.26	0.280

<sup>a</sup>0.04 percent N

<sup>b</sup>0.29 percent N

TABLE 4-8. MODEL HEATERS AND UNCONTROLLED EMISSION FACTORS:  
 NATURAL GAS-FIRED AND HIGH-HYDROGEN FUEL GAS-FIRED  
 OLEFINS PYROLYSIS FURNACES<sup>28</sup>

Model heater capacity, MMBtu/hr	Fuel	No. of burners	Uncontrolled NO <sub>x</sub> emission factor, lb/MMBtu
84	Natural gas	24	0.135
84	High-hydrogen fuel gas	24	0.162

#### 4.4 REFERENCES FOR CHAPTER 4

1. Shareef, S. A., C. L. Anderson, and L. E. Keller (Radian Corporation). Fired Heaters: Nitrogen Oxides Emissions and Controls. Prepared for U. S. Environmental Protection Agency. Research Triangle Park, NC. EPA Contract No. 68-02-4286. June 1988. pp. 42-48.
2. Control Techniques for NO<sub>x</sub> Emissions from Stationary Sources - Revised Second Edition. U. S. Environmental Protection Agency. Research Triangle Park, NC. Publication No. EPA-450/3-83-002. January 1983. p. 2-1.
3. Standard Support and Environmental Impact Statement Volume 2: Proposed Standards of Performance for Stationary Gas Turbines. U. S. Environmental Protection Agency. Research Triangle Park, NC. Publication No. EPA-450/2-77-017a. September 1977. pp. 3-71 to 3-73.
4. Letter from Nichols, K., Chemical Recovery Group, to Safriet, D., EPA/ISB. January 9, 1992. NO<sub>x</sub> emissions from recovery furnaces.
5. Newman, C. R. (GCA Corporation). Assessment of NO<sub>x</sub> Emission Factors For Direct-Fired Heaters. Prepared for U. S. Environmental Protection Agency. Research Triangle Park, NC. EPA Contract No. 68-02-2693. January 1984. pp. 16-19.
6. Reference 2, p. 3-4.
7. Campbell, L. M., D. K. Stone, and G. S. Shareef (Radian Corporation). Sourcebook: NO<sub>x</sub> Control Technology Data. Prepared for U. S. Environmental Protection Agency. Research Triangle Park, NC. EPA-600/2-91-029. July 1991.
8. Letter and attachments from Pam, R., Alzeta Corporation, to Neuffer, W., EPA/ISB. September 2, 1992. Comments on Draft Alternative Control Techniques Document--Control of NO<sub>x</sub> Emissions from Process Heaters.
9. Reference 7, p. 5.
10. Malte, P. C. Perspective on NO<sub>x</sub> Formation and Control for Gas Turbine Engines. University of Washington (Seattle, WA) and Energy International (Bellevue, WA). Presented at General Electric Research Center. Schenectady, NY. October 10, 1988. 46 pp.
11. Reference 1, pp. 48-52.
12. Martin, R. R. Burner Design Parameters for Flue Gas NO<sub>x</sub> Control. John Zink Company. Tulsa, Oklahoma. Undated. 39 pp.

13. Reference 5, p. 20.
14. Reference 1, pp. 57-59.
15. Reference 1, pp. 53-56.
16. Letter and attachments from Eichamer, P., Exxon Chemical Company, to Neuffer, W., EPA/ISB. September 2, 1992. Comments on Draft Alternative Control Techniques Document--Control of NO<sub>x</sub> Emissions from Process Heaters.
17. Reference 1, pp. 18-19.
18. Letter and attachments from Pam, R., Alzeta Corporation, to Lyons, J., MRI. February 26, 1992. Alzeta product literature.
19. Energy Section, Strategy Assessment Branch, Stationary Source Division Air resources Board and Rule Development Division, South Coast Air Quality Management District. A Suggested Control Measure for the Control of Emissions of Oxides of Nitrogen from Industrial, Institutional, and Commercial Boilers, Steam Generators and Process Heaters. Prepared for the Statewide Technical Review Group. Sacramento, CA. April 29, 1987. p. 51.
20. Letter and attachments from Martin, R., Aztec Environmental and Combustion Engineers, to Neuffer, W., EPA/ISB. January 26, 1993. Comments on Draft Alternative Control Techniques Document--Control of NO<sub>x</sub> Emissions from Process Heaters.
21. Padgett Process Services Ltd. A Study to Assess the Available Technology and Associated Costs of Reducing NO<sub>x</sub> Emissions from the Canadian Petroleum Refining Industry. Prepared for Canadian Petroleum Products Institute. Toronto, Canada. CPPI Report No. 91-1. November 28, 1990. p. 56.
22. Reference 1, p. 44.
23. Compilation of Air Pollutant Emission Factors Volume 1: Stationary Point and Area Sources, Fourth Edition (AP-42). U. S. Environmental Protection Agency. Research Triangle Park, NC. October 1986. pp. 1.3-2, 1.4-2.
24. Hunter, S. C., and S. S. Cherry (KVB-A Research-Cottrell Company). NO<sub>x</sub> Emissions from Petroleum Industry Operations. Prepared for the American Petroleum Institute. Washington, D.C. API Publication No. 4331. October 1979. pp. 27-30.



25. Letter and attachments from Davis, L., Exxon Company U.S.A., to Harris, R., MRI. February 7, 1992. Process heater inventory of the Baton Rouge refinery.
26. Letter from Eichamer, P. D., and N. L. Morrow, Exxon Chemical Company, to Neuffer, W. J., EPA/ISB. June 7, 1993. Pyrolysis furnace NO<sub>x</sub> emission rates.
27. Letter from Moran, E. J., Chemical Manufacturers Association, to Neuffer, W. J., EPA/ISB. July 22, 1993. Pyrolysis furnace NO<sub>x</sub> emission rates.
28. Letter from Eichamer, P. D., and N. L. Morrow, Exxon Chemical Company, to Neuffer, W. J., EPA/ISB. July 19, 1993. Pyrolysis furnace NO<sub>x</sub> emission rates.

## 5.0 NO<sub>x</sub> CONTROL TECHNIQUES

In this chapter, NO<sub>x</sub> control techniques for process heaters are discussed. Nitrogen oxides control techniques for process heaters can be categorized as either combustion controls or postcombustion controls. Section 5.1 describes combustion controls. Sections 5.2 and 5.3 address postcombustion controls. Pyrolysis furnaces, which consume a large portion of the energy used in basic chemical plants, operate at much higher temperatures than other process heaters and are a special consideration. Pyrolysis furnaces are discussed separately in Section 5.4. Section 5.5 presents a summary of the achievable emission reductions for NO<sub>x</sub> control techniques as applied to model process heaters. References for Chapter 5 are presented in Section 5.6.

### 5.1 COMBUSTION CONTROLS

As discussed in Chapter 4, the main factors contributing to NO<sub>x</sub> formation include combustion temperature, available oxygen, and fuel nitrogen content. Combustion modifications attempt to reduce NO<sub>x</sub> formation by controlling the first two factors. Control of excess air reduces the amount of oxygen available to combine with dissociated nitrogen and is discussed in Section 5.1.1. Combustion staging methods reduce NO<sub>x</sub> formation by either reducing available oxygen or providing excess oxygen to cool the combustion process. Combustion air preheat is often used in process heaters to improve thermal efficiency. Because preheated combustion air increases combustion temperatures, thermal NO<sub>x</sub> formation is increased. Combustion air preheat is discussed in Section 5.1.2. Staged combustion incorporating air lancing is discussed in Section 5.1.3. The technique of staging

combustion air was later incorporated into the design and development of staged-air burners and is described in Section 5.1.4. Fuel staging, discussed in Section 5.1.5, is a more recently developed burner staging technique. Flue gas recirculation (FGR) has been used as a  $\text{NO}_x$  control technique for boilers but has had limited application to process heaters. A discussion of FGR for process heaters is provided in Section 5.1.6. More recently, a class of burners has been developed that uses a variety of techniques and is generally referred to as ultra-low- $\text{NO}_x$  burners. In addition to staged combustion, these burners may incorporate internal FGR and steam injection; they are discussed in Section 5.1.7. Section 5.1.8 covers a separate class of burners, referred to as radiant burners, which use a ceramic catalyst enclosing the burner tip.

#### 5.1.1 Low Excess Air

Low-excess-air (LEA) control systems optimize the amount of air available for combustion. Optimizing the combustion air supply reduces both fuel consumption and  $\text{NO}_x$  formation. Decreased local oxygen concentrations, due to minimal excess air in the combustion zone, forms a reducing atmosphere, which inhibits the formation of both thermal and fuel  $\text{NO}_x$ . Additionally, the resulting lower flue gas temperature further reduces the formation of thermal  $\text{NO}_x$ . Thermal efficiency is increased by reducing the heat loss associated with the heating excess air not required for combustion. More heat is therefore transferred to the process fluid per unit of energy input, thus requiring less fuel to provide the required heat flux. The actual efficiency improvement obtained for a given heater depends on the flue gas temperature and on the heat response of the heater to the reduced flue gas flow under LEA conditions.<sup>1-4</sup>

The effectiveness of any LEA control system in reducing  $\text{NO}_x$  emissions from a fired heater depends on (1) the long-term average excess air level that can be maintained in the heater and (2) the relationship between  $\text{NO}_x$  emissions and oxygen ( $\text{O}_2$ ) in the heater.<sup>1</sup> The lowest excess air level that can be maintained in a fired heater depends on draft type, fuel type, degree of air

leakage into the heater, and the ability of the excess air control system to respond quickly to changes in fuel composition and heater load. The relationship between  $\text{NO}_x$  emissions and  $\text{O}_2$  for a particular heater depends on draft type, fuel type, burner type, and degree of combustion air preheat. Optimal excess  $\text{O}_2$  levels are therefore different for each heater.

Draft type influences the excess air level attainable in older heater designs by affecting the degree of fuel/air mixing in the burner. Mechanical draft (MD) burners generally operate with a higher pressure drop than natural draft (ND) burners, resulting in improved fuel/air mixing. Consequently, MD heaters can achieve complete combustion at lower excess air levels than ND heaters. This is not necessarily the case in recent burner designs, however, as one source reports that ND burners can be operated at excess air levels similar to MD burners.<sup>5</sup>

The minimum excess air level is also affected by fuel type. Fired heaters combust gas, oil, or a combination of gas and oil. Gas-fired heaters generally require a lower excess air level than oil-fired heaters. Variations in fuel composition such as those often associated with refinery gas may affect the ability of some LEA control systems to continuously maintain stack  $\text{O}_2$  levels. Data from tests conducted from 1978 through 1982 indicate that, on average, a 9 percent reduction in  $\text{NO}_x$  accompanies each 1 percent reduction in stack  $\text{O}_2$  levels when stack  $\text{O}_2$  levels are between 2 and 6 percent. For example, reducing the average long-term stack oxygen level of a heater using LEA control techniques from 5.5 percent  $\text{O}_2$  to 2 percent  $\text{O}_2$  would result in a 32 percent reduction in  $\text{NO}_x$  emissions.<sup>1</sup> Current experience for one source is that  $\text{NO}_x$  reductions of 6 percent are achieved for every one percent reduction in excess  $\text{O}_2$ . This ratio is lower than the 9:1  $\text{NO}_x$  reduction ratio discussed above and probably reflects recent improvements in heater and burner designs with reduced excess air levels.

Current practice is to control excess air to improve heater efficiency. However, retrofitting older heaters that lack LEA equipment may require a large capital investment to achieve

optimal excess air operation.<sup>5</sup> Excess O<sub>2</sub> levels of approximately 2 to 4 percent appear to provide the best balance of maximum heater thermal efficiency and NO<sub>x</sub> and CO emission reductions. Appendix A presents a refinery process heater inventory and suggests that excess air is already maintained at or near optimal conditions. As discussed earlier, O<sub>2</sub> optimal conditions are different for every heater. For this reason, control of excess air should be viewed as an expected standard operating procedure and not as a potential retrofit NO<sub>x</sub> control method for substantial NO<sub>x</sub> reductions.

#### 5.1.2 Combustion Air Preheat

Combustion air preheat is often used in conjunction with MD heaters to improve heater thermal efficiency. An MD heater with air preheaters will typically have an exhaust gas temperature of 260°C (500°F). Thermal efficiency for heaters of this type can be as high as 92 percent.<sup>1</sup> As discussed in Chapter 4, this increase in thermal efficiency with the addition of air preheat is associated with increases in thermal NO<sub>x</sub> formation. Reducing air preheat in MD heaters reduces thermal NO<sub>x</sub> formation at the expense of heater efficiency. This loss of heater efficiency can be partially offset by adding a convection section heat recovery unit (or increasing the size of the existing one). As discussed in Section 5.1.7, NO<sub>x</sub> emissions from radiant burners appear to be unaffected by combustion air preheat.

Figure 5-1 illustrates the typical relationship between combustion air preheat and NO<sub>x</sub> emissions. An increase in air preheat from ambient to 260°C (500°F) increases NO<sub>x</sub> formation by a factor of approximately two. This result is supported by the refinery/inventory survey shown in Appendix A. Those heaters using inlet air at ambient conditions show significantly lower emissions than comparable units at elevated preheat levels. Most heaters equipped with preheaters do not have control of the level of air preheat.

#### 5.1.3 Use of Air Lances to Achieve Staged Combustion

Early efforts to stage combustion used air lances to separate the combustion process and limit NO<sub>x</sub> formation. In the

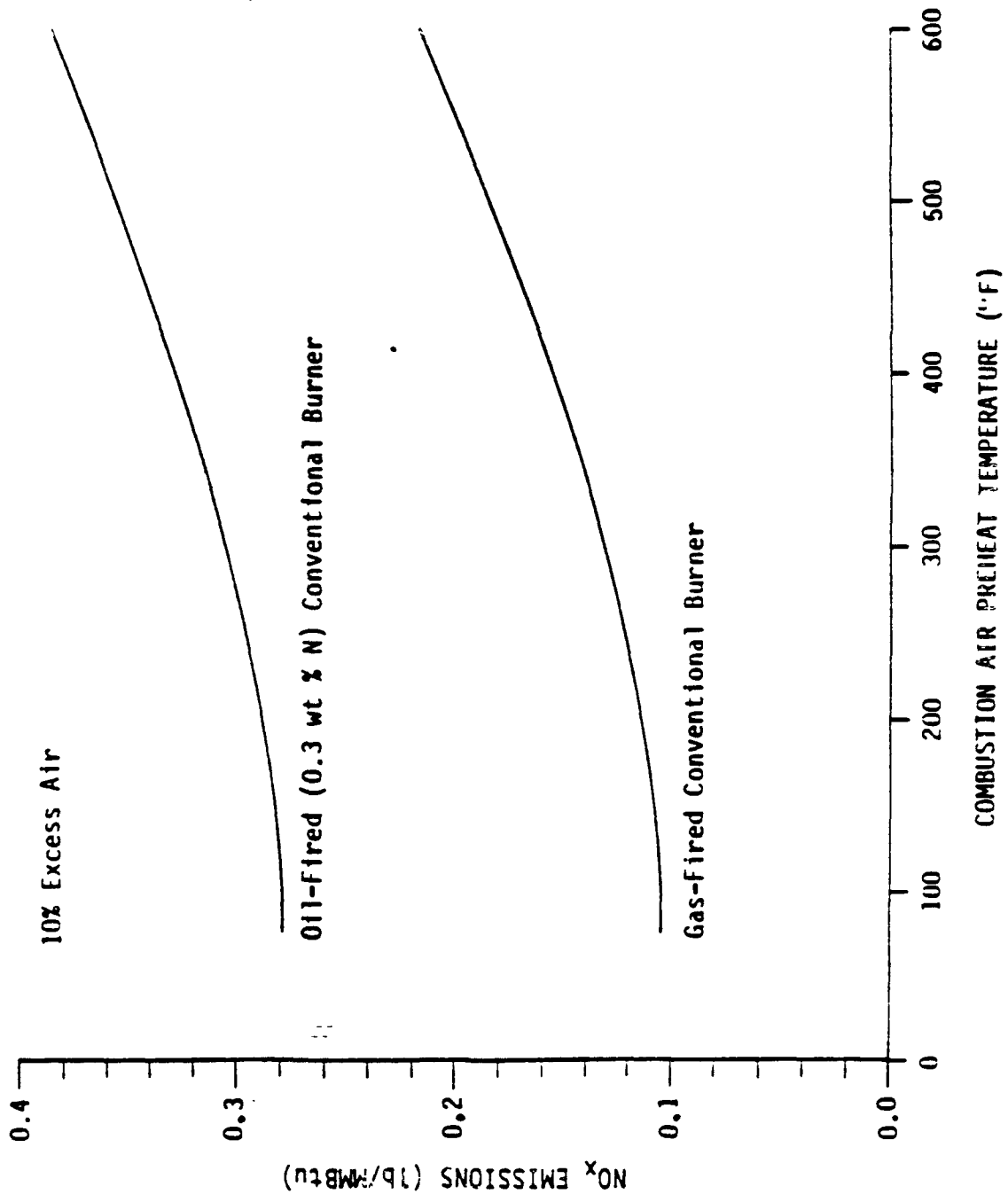

Figure 5-1. Effect of combustion air preheat temperature on NO<sub>x</sub> emissions. 1

primary combustion zone, a rich mixture is combusted with the air lances supplying jets of air in the secondary combustion zone to complete the oxidation of the fuel. A schematic diagram of a staged combustion system using air lances is presented in Figure 5-2. The range of uncontrolled and achievable controlled emissions reported in References 2 and 3 is presented in Table 5-1.<sup>2,3</sup> Nitrogen oxide reductions from uncontrolled levels using air lances for heaters firing refinery gas range from 12 to 71 percent.<sup>2,3</sup> Reductions for heaters that combine firing of No. 6 fuel-oil and refinery gas range from 25 to 54 percent.

Although staged combustion air (SCA) is potentially applicable to many fired heaters, its use may be restricted by several limitations.<sup>1</sup> As the degree of staging is increased, the flame quality and temperature decrease, and the uniformity of the heat flux provided by the flame is impaired. In process heater applications in which the process fluid flow may be seriously affected by variations from the design heat flux distribution, staged air lances may not be applicable. For example, reforming heaters and vacuum heaters often have process fluids of more than one phase or at high temperatures that require a constant heat flux distribution. Other heater types, such as crude oil heaters, have been demonstrated to more readily tolerate changes in heat flux and temperature. Other limitations include the possibly corrosive environment due to staged combustion within the heater, which leads to frequent replacement of air lances. A larger flame zone would be required in some heaters to accommodate the lengthened flame associated with staged combustion.

The development of staged burners incorporating air staging or fuel staging has eliminated the need for extensive air supply piping and removed many of the flame difficulties associated with air lance staging. One source reports that no known commercial applications of air lances exists.<sup>6</sup> For this reason, air staging using air lances should not be considered a current NO<sub>x</sub> control approach.

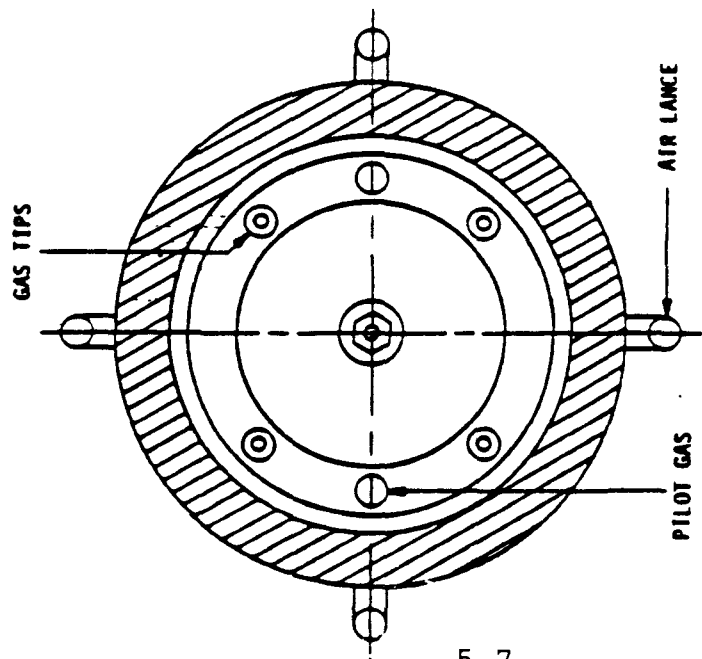
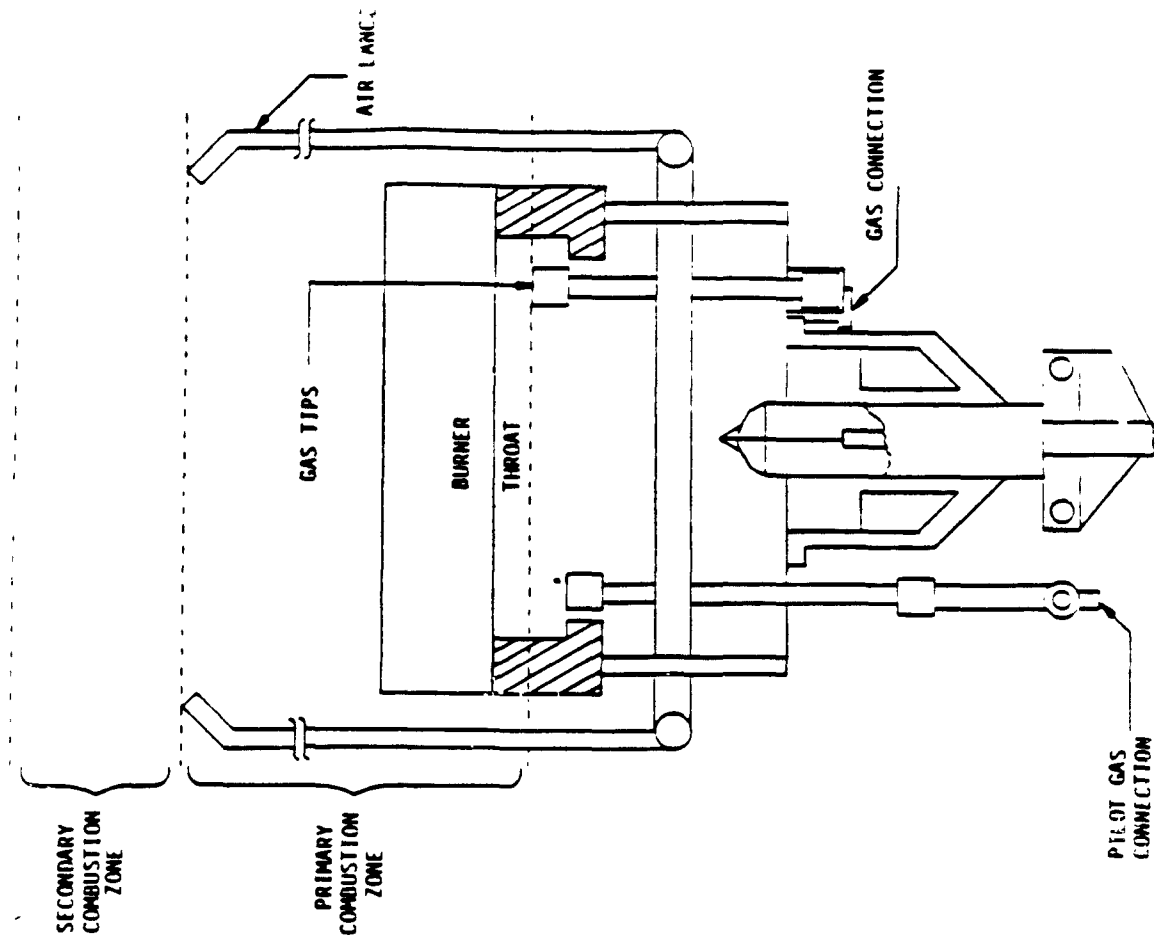

Figure 5-2. Staged combustion air lances installed on a conventional gas burner.<sup>1</sup>



TABLE 5-1. CONTROLLED EMISSIONS FOR STAGED COMBUSTION  
USING AIR LANCES<sup>2,3</sup>

Fuel	Uncontrolled NO <sub>x</sub> emissions		NO <sub>x</sub> reduction, percent	Controlled NO <sub>x</sub> emissions	
	ppmv <sup>a</sup>	lb/MMBtu		ppmv <sup>a</sup>	lb/MMBtu
Refinery gas	138	0.165	12	121	0.144
Refinery gas	125	0.243	71	36.3	0.043
Residual oil and refinery gas	265	0.334	25	199	0.251
Residual oil and refinery gas	214	0.270	53	101	0.127

<sup>a</sup>At 3 percent O<sub>2</sub>.

#### 5.1.4 Staged-Air, Low-NO<sub>x</sub> Burners

Staged-air techniques have been incorporated into the burner design. Although staging techniques are effective in reducing NO<sub>x</sub> emissions, flame shape can be detrimentally affected. Staged-air, low-NO<sub>x</sub> burners (LNB's) are usually larger than conventional burners and generally require extensive retrofitting operations. Emission reductions achieved by staged-air LNB's range from 30 to 40 percent below emissions from conventional burners.<sup>1,7,8,9</sup> Using the uncontrolled emission factors from Table 4-3 and a 40 percent NO<sub>x</sub> emission reduction, the expected controlled NO<sub>x</sub> emissions for staged-air LNB are presented in Table 5-2. The emissions are presented for ND and MD gas-, distillate oil-, and residual oil-fired heaters. The uncontrolled emissions range from 0.14 lb/MMBtu for ND gas-fired heaters to 0.42 lb/MMBtu for MD residual oil-fired heaters. The controlled emissions range from 0.084 lb/MMBtu for ND gas-fired heaters to 0.318 lb/MMBtu for MD residual oil-fired heaters.

Table 5-3 presents several staged-air burners and estimated performance. For heavy fuel oil (HFO) firing (0.3 percent N content), staged-air LNB's produce about 250 ppmv of NO<sub>x</sub> at 3 percent O<sub>2</sub> (0.315 lb/MMBtu). This reflects approximately a 40 percent reduction in NO<sub>x</sub> emissions from conventional burners. For gas fuels, staged-air LNB's produce a lower bound of approximately 80 to 100 ppmv NO<sub>2</sub> at 3 percent O<sub>2</sub> (0.096 to 0.119 lb/MMBtu) with 260°C (500°F) preheat.

Most early LNB design efforts centered on bypassing some of the combustion air around the conventional burner combustion zone. Typically, as shown in Figure 5-3, these "air-staged" designs use a tertiary combustion zone since most of the standard burners already have primary and secondary air mixing. Tertiary air, containing the "excess" portion (10 to 20 percent) of combustion air, is introduced around the outside of the secondary combustion zone so that unburned fuel and O<sub>2</sub> mix/react more by diffusion than by turbulent mixing. This technique maximizes the time during which fuel burns in substoichiometric conditions.

TABLE 5-2. CONTROLLED EMISSION LEVELS FOR STAGED-AIR LNB'S

Fuel	Draft type	Uncontrolled NO <sub>x</sub> emission factors		Controlled NO <sub>x</sub> emission levels <sup>b</sup>	
		ppm <sup>a</sup>	lb/MMBtu	ppm <sup>a</sup>	lb/MMBtu
Gas	ND	111	0.14	66.6	0.084
Distillate oil	ND	159	0.20	95.2	0.120
Residual oil	ND	333	0.42	200	0.250
Gas	MD	206	0.26	124	0.156
Distillate oil	MD	254	0.32	152	0.195
Residual oil	MD	421	0.53	253	0.318

<sup>a</sup>@3 percent O<sub>2</sub>

<sup>b</sup>Controlled emissions based on a 40 percent reduction.

TABLE 5 - 3. STAGED-AIR BURNER NO<sub>x</sub> CONTROL PERFORMANCE AND EMISSION LEVELS

Burner name	Heater draft	Fuel	NO <sub>x</sub> control performance and emission levels	
			ppmv <sup>b,h</sup>	lb/MMBtu
John Zink Low-NO <sub>x</sub> HIV <sup>a</sup>	MD	NG <sup>b</sup>	40 to 105	0.048 to 0.125
		HFO <sup>c</sup>	250 to 270	0.315 to 0.340
John Zink LNC <sup>a</sup>	ND	NG	85	0.101
	(60°F)	HFO		
McGill NRGR <sup>a,b</sup>	MD <sup>d</sup>	NG	105	0.125
	(500°F preheat)	HFO	270	0.340
McGill NCR <sup>a,b</sup>	ND	NG	40% reduction	40% reduction
	MD	NG	40% reduction	40% reduction
Hamworthy LV <sup>a</sup>	ND	Combination	40% reduction	40% reduction
	MD	Combination	40% reduction	40% reduction
AUSCS DFR Low NO <sub>x</sub> <sup>a</sup>	MD	Oil/gas	40% reduction	0.039 to 0.053
		NG	33 to 44 (no preheat) 54 to 57 (600°F preheat, lean gas)	0.064 to 0.068
AUSCS 200 <sup>a</sup>	ND/MD	NG	37 ppmv (without preheat using ND)	0.044
Callidus Staged-Air LNBC	ND	NG	30% reduction	30% reduction
	MD (preheat) <sup>d</sup>	NG	30% reduction	30% reduction

<sup>a</sup>Reference 7. Vendor names are presented as found in the reference and are included only to identify the burner type. Other vendors may offer similar burner types.

<sup>b</sup>McGill has been purchased by John Zink Company. McGill burners are no longer available, but replacements can be obtained from the John Zink Company.

<sup>c</sup>Reference 9. Vendor names are included only to identify the burner type. Other vendors may offer similar burner types.

<sup>d</sup>Preheat temperature is not known.

<sup>e</sup>Natural gas.

<sup>f</sup>Heavy fuel oil.

<sup>g</sup>At 3 Percent O<sub>2</sub>.

<sup>h</sup>Percent reductions were not available for all burners

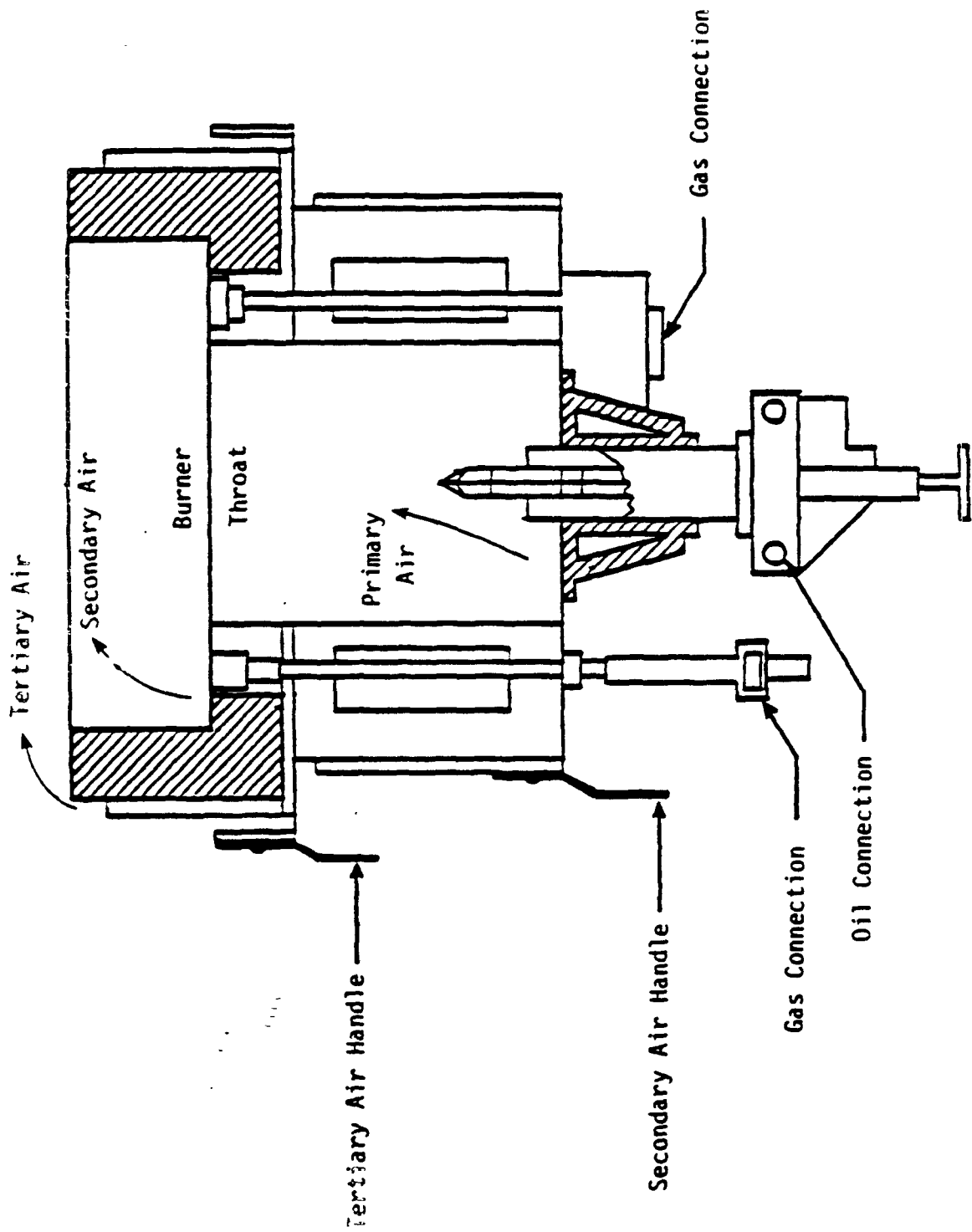

Figure 5-3. Schematic of a staged-air low-NO<sub>x</sub> burner. 8

The theoretical basis for air staging is that the initial combustion of fuel takes place in a fuel-rich reducing atmosphere in which  $N_2$  is preferentially formed rather than  $NO_x$ . The flame temperature in the initial combustion zone is high due to the low combustion air/fuel ratio, but thermal  $NO_x$  formation is limited by the low  $O_2$  concentration.

For heavy fuel oil (HFO) combustion, staged-air burners are more suitable than staged-fuel burners.<sup>10</sup> The reducing conditions prevailing in certain makes of staged-air burners (particularly those with longer primary zone residence times) are thought to have a greater impact on fuel  $NO_x$  reduction than the staged-fuel burner, which essentially affects only thermal  $NO_x$ . Fuel  $NO_x$  reduction is the key issue in overall  $NO_x$  reduction for high-nitrogen-content liquid fuels such as HFO.

The major problem with high-performance LNB retrofitting is that flames tend to be larger and less well-defined than those of the standard burners they are replacing. The altered flame pattern is caused by diffusion mixing and delayed combustion resulting from the air staging. The tendency for larger, less well-defined flames is more pronounced for ND than for MD burners and more so for oil than for gas firing. However, one source reports that problems resulting from flame pattern alteration can be minimized or eliminated if the burner system is properly designed. Design considerations that affect the flame characteristics include burner tip placement, burner tip hole sizes and angles, placement of the flue gas recycle ducts, and burner tile shape.<sup>5</sup>

Another problem with LNB's is that retrofit operations may require extensive modifications to the heater. A large number of process heaters are floor-fired, and limited space under the heater may increase retrofit cost significantly because LNB's require larger air plenums than conventional burners.<sup>5</sup> Other typical retrofit operations include multiple fuel header connections, steam header connections, and flue gas ducting alterations.<sup>5</sup>

Spacing between burner center lines varies appreciably from one heater design to another, typically within a range of 0.6 to 1.7 meter (m) (2 to 5.6 feet [ft]) (most are greater than 1.0 m [3.3 ft]). In general, retrofitting heaters that have a spacing of less than 1 m may not be practical because of potential flame impingement. In the case of heaters in critical services (i.e., those with high process temperatures or pressures) such as catalytic reforming, steam/methane reforming, hydrocracking, olefin cracking, etc., this minimum spacing may be as high as 1.4 m (4.6 ft) because of the need to minimize heat flux variations around the tubes.

The NO<sub>x</sub> emissions from LNB's are much more sensitive to excess air than are emissions from standard burners. Since improved control of excess air is more readily achieved with MD combustion air systems, an effective NO<sub>x</sub> reduction strategy for ND process heaters is a retrofit involving conversion to MD, excess O<sub>2</sub> control, and LNB's. The benefits of such a retrofit are:

1. Improved flame definition relative to an ND heater with LNB's;
  2. Reduced excess air, resulting in energy savings; and
- For MD process heaters, an effective LNB retrofit would involve installing both excess O<sub>2</sub> control and LNB's.

Another limitation on LNB applications is the existing burner design heat release rate. Most LNB's have a minimum design heat release of about 3,000 to 9,000 MJ/hr (3 to 9 MMBtu/hr). Certain heaters, such as steam/methane reformers, are typically designed with a large number of small burners with duties that may fall below the minimum LNB heat release.

From the above discussion, it is apparent that not all process heaters are suitable for LNB retrofitting, although the majority will qualify. In the case of heaters with multiple small burners, the cost of a burner retrofit is high even when it is technically feasible so that alternative low-NO<sub>x</sub> solutions may be more attractive.

#### 5.1.5 Staged-Fuel Low-NO<sub>x</sub> Burners

Staged-fuel LNB's were more recently developed than staged-air LNB's. Designed for gas firing, staged-fuel LNB's separate the combustion zone into two regions. The first is a lean primary region in which the total quantity of combustion air is supplied with a fraction of the fuel. In the second region, the remainder of the fuel is injected and combusted by the oxygen left over from the primary region. This technique inhibits the formation of thermal NO<sub>x</sub>, but has little effect on fuel NO<sub>x</sub> formation.

Figure 5-4 presents a schematic of a typical staged-fuel LNB. In a typical staged-fuel LNB, 40 to 70 percent of the fuel is bypassed around the primary combustion region.<sup>7,11</sup> Combustion in the primary region, therefore, takes place in the presence of a large excess of O<sub>2</sub> at substantially lower temperatures than the standard burner. The remaining fuel is introduced around the outside of the primary combustion zone so that fuel and unburned O<sub>2</sub> mix/react by diffusion rather than turbulent mixing and substoichiometric reducing conditions are maximized.

For gaseous fuels that do not contain fuel-bound nitrogen, NO<sub>x</sub> reduction performance from fuel staging is better than that from air staging. The low-temperature/high-O<sub>2</sub> conditions of the staged-fuel LNB have a stronger effect on thermal NO<sub>x</sub> reduction than do the high-temperature/low-O<sub>2</sub> conditions of the staged-air LNB.<sup>7</sup>

Staged-fuel LNB's have several advantages over staged-air LNB's. First, the improved fuel/air mixing due to the pressurized injection of the secondary region fuel reduces the excess air operating level necessary to ensure complete combustion. The lower excess air both reduces NO<sub>x</sub> formation and improves heater efficiency. Second, for a given peak flame temperature, staged-fuel LNB's have a more compact flame than staged-air LNB's.<sup>1</sup> Staged-fuel burners have been installed as wall-, floor- and roof-mounted burners and have found use in the full range of process applications from crude oil heaters to downstream conversion processes.



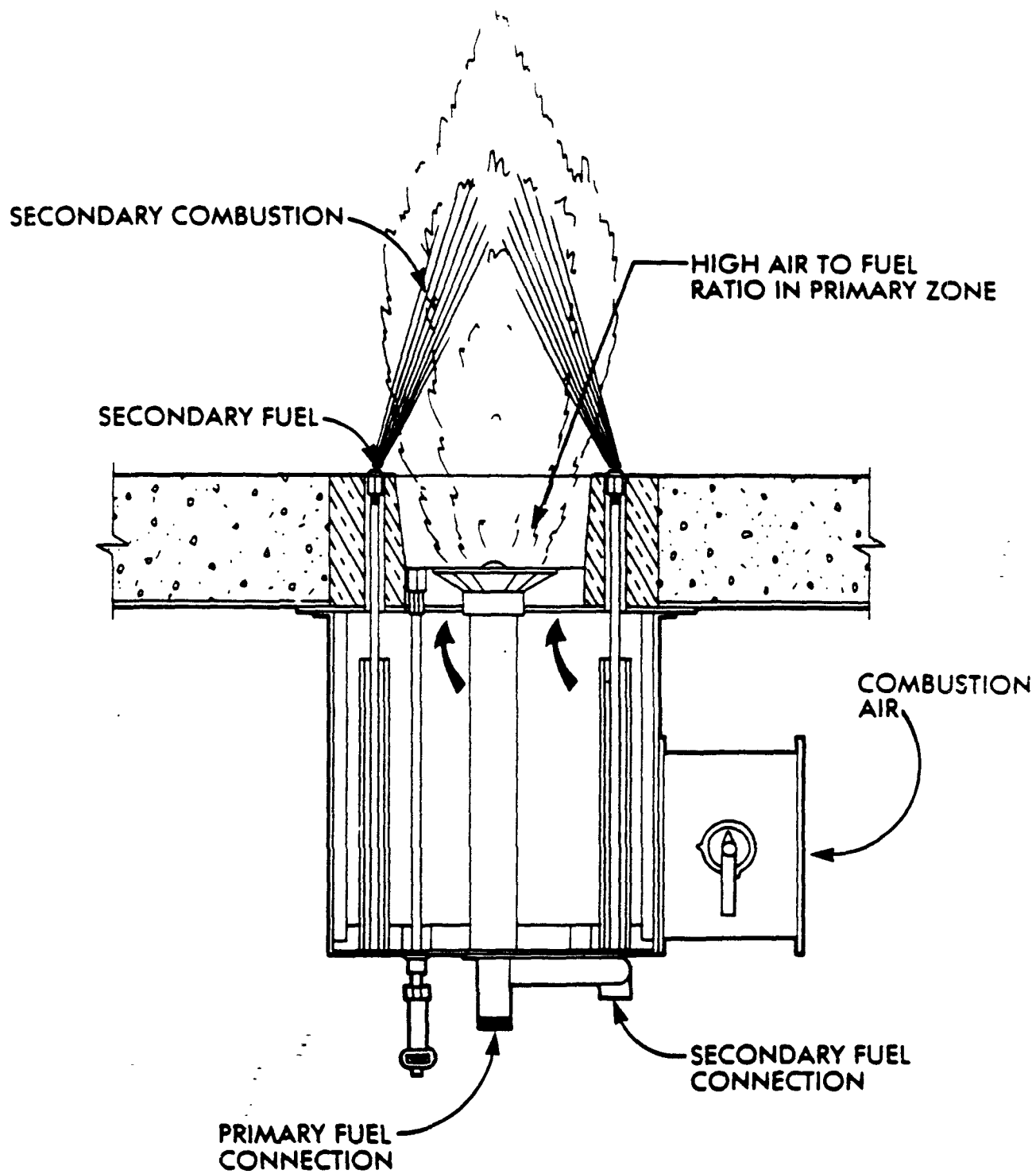

Figure 5-4. Schematic of a staged-fuel low- $\text{NO}_x$  burner.<sup>1</sup>

Reductions in NO<sub>x</sub> emissions of up to 72 percent have been reported over conventional burners based on vendor test data for staged-fuel LNB's.<sup>1</sup> The average reduction is approximately 60 percent.<sup>1,7,9,12</sup> Table 5-4 presents controlled NO<sub>x</sub> emission levels for several staged-fuel LNB's. The controlled emissions ranged from 40 to 50 ppmv at 3 percent O<sub>2</sub> (0.048 to 0.060 lb/MMBtu); uncontrolled emission levels, and therefore percent reductions, were not available.<sup>7</sup> Table 5-5 presents controlled emission levels for gas-fired heaters using uncontrolled emission factors from Table 4-3 and a 60 percent reduction. The controlled NO<sub>x</sub> emission levels are 0.056 and 0.104 lb/MMBtu for ND and MD heaters, respectively. The data in Table 5-4 indicate that the combination fuel burners, i.e., burners that fire a gas and oil mixture, can achieve approximately the same emission levels as the gas-fired burners. However, it is expected that combination fuels will generally produce higher NO<sub>x</sub> emissions than gas-only fuels. The data in Table 5-4 also indicate that controlled emissions for ND burners are only 10 ppmv less than MD burners with preheat. As shown in Table 4-2, NO<sub>x</sub> emissions for process heaters with preheat are approximately 1.25 to 2 times that of process heaters without preheat, so controlled emissions for ND and MD burners in general would be expected to differ by more than 10 ppmv. It is expected that the controlled emissions for the MD gas-fired John Zink SFG LNB in Table 5-4 would have similar emissions as the MD heater in Table 5-5.

#### 5.1.6 Flue Gas Recirculation

Flue gas recirculation (FGR) generally involves forced return of flue gas to the burners and introduces the air/flue gas mixture into the combustion zone. This technique is usually referred to as external FGR.

Flue gas recirculation is a NO<sub>x</sub> emission reduction technique based on recycling 15 to 30 percent of the essentially inert products of combustion (flue gas) to the primary combustion zone.<sup>5</sup> The recirculation of flue gas dilutes the combustion reactants, reduces the peak flame temperature, and reduces the

TABLE 5-4. STAGED-FUEL LOW-NO<sub>x</sub> BURNER CONTROLLED NO<sub>x</sub> EMISSION LEVELS<sup>7</sup>

Burner name	Heater draft	Fuel	Controlled NO <sub>x</sub> emissions	
			ppmv <sup>g,h</sup>	lb/MMBtu
John Zink SFG <sup>a</sup>	ND <sup>d</sup>	Gas	40 to 50	0.048 to 0.060
	MD (500°F preheat)	Gas	40 to 50	0.048 to 0.060
John Zink SFG <sup>a</sup>	ND <sup>d</sup>	Combination <sup>f</sup>	40	NA
	MD (500°F preheat)	Combination <sup>f</sup>	50	NA
McGill SRGR <sup>a,b</sup>	ND <sup>d</sup>	Refinery gas 50 percent H <sub>2</sub>	45	0.054
	MD <sup>d</sup>	Refinery gas 50 percent H <sub>2</sub>	45	0.054
Callidus CSG <sup>c</sup>	ND <sup>d</sup>	NG	60% reduction	60% reduction
	MD (preheat) <sup>e</sup>	NG	60% reduction	60% reduction

<sup>a</sup>Reference 7. Vendor names are presented as found in the reference and are included only to identify the burner type. Other vendors may offer similar burner types.

<sup>b</sup>McGill has been purchased by John Zink Company. McGill burners are no longer available, but replacements can be obtained from the John Zink Company.

<sup>c</sup>Reference 9. Vendor names are included only to identify the burner type. Other vendors may offer similar burner types.

<sup>d</sup>Combustion air at ambient conditions.

<sup>e</sup>Preheat temperature is not known.

<sup>f</sup>Combination of oil and gas fuels.

<sup>g</sup>At 3 percent O<sub>2</sub>.

<sup>h</sup>Percent reductions were not available for all burners.

NA = Not available.

TABLE 5-5. CONTROLLED NO<sub>x</sub> EMISSION LEVELS FOR STAGED-FUEL  
LOW-NO<sub>x</sub> BURNERS<sup>a</sup>

Draft type	Uncontrolled NO <sub>x</sub> emissions		Controlled NO <sub>x</sub> emissions <sup>c</sup>	
	ppmv <sup>b</sup>	lb/MMBtu	ppmv <sup>b</sup>	lb/MMBtu
ND	117	0.14	47	0.056
MD	218	0.26	87	0.104

<sup>a</sup>Gas firing.

<sup>b</sup>At 3 percent O<sub>2</sub>.

<sup>c</sup>Controlled emissions based on a 60 percent reduction.

local oxygen concentrations, thereby inhibiting thermal NO<sub>x</sub> formation. However, FGR is believed to have only a small effect on fuel NO<sub>x</sub> formation.<sup>1,7</sup>

Conventional burners can be used with modifications to accept the increased gas flow. Success with external FGR on boilers demonstrates the capability of the technique, but FGR has been used on only a few fired heaters. Several inherent drawbacks limit its potential use with process heaters. Flue gas recirculation requires a relatively large capital investment because of the need for high-temperature fans and ductwork. Furthermore, it may not apply to all types of fired heaters. The low flame temperature and susceptibility to flame instability limits FGR usage in high-temperature applications. In addition, FGR can only be used on MD heaters. Since FGR is believed to have only a small effect on fuel NO<sub>x</sub> formation, FGR may not be as effective on oil-fired heaters as on gas-fired heaters.<sup>5</sup>

The only NO<sub>x</sub> emission data currently available on a fired heater using FGR consist of five spot measurements on a 10 MW (100 MMBtu/hr) crude oil heater with mechanical draft, ambient combustion air, and unknown fuel and burner type. The average operating conditions of the heater were 74 percent load, 620°C (1150°F) FGR temperature, and 14 percent stack gas oxygen content. The average NO<sub>x</sub> emissions from the heater were 78.1 nanograms per Joule (ng/J) (0.012 lb/MMBtu).<sup>1</sup>

For small heaters, North American Manufacturing Company is marketing a mass flow, FGR controller. On a 10 MM Btu/hr, single-burner Dowtherm® heater, NO<sub>x</sub> emission levels of less than 30 ppmv at 3 percent O<sub>2</sub> (0.036 lb/MMBtu) have been achieved.<sup>13</sup> This system incorporates LNB's and external FGR.

Based primarily on boiler data, reductions using external FGR for process heaters are given as 55 percent for both oil and gas firing when used in combination with LNB's.<sup>7</sup> Also, based on boiler data, FGR used with standard burners on process heaters is expected to reduce NO<sub>x</sub> emission levels 30 percent.<sup>7</sup>

### 5.1.7 Ultra-Low NO<sub>x</sub> Burners

Ultra-low NO<sub>x</sub> burners refer to a class of burners recently developed to meet the South Coast Air Quality Management District (SCAQMD) Rule 1109 NO<sub>x</sub> emission requirements. These burners may incorporate a variety of techniques including internal or self recirculating flue gas (IFGR), steam injection, or a combination of techniques.

These burners are designed to recirculate hot, O<sub>2</sub>-depleted flue gas from the flame or firebox back into the combustion zone. This reduces the average O<sub>2</sub> concentration within the flame without reducing the flame temperature below temperatures necessary for optimal combustion efficiency.<sup>7</sup> All designs, as depicted in Figure 5-5, use a venturi effect to induce hot flue gas back into the primary combustion zone. Fuel gas injection via primary or secondary burner tips and steam injection can be used to create the venturi effect.

Reduced O<sub>2</sub> concentrations in the flame have a strong impact on fuel NO<sub>x</sub>, so IFGR burners are an effective NO<sub>x</sub> control technique for heaters firing nitrogen-bearing fuel oil. This is especially true when combined with staged-air combustion, as exemplified in the John Zink MNC and Hague International Transjet burners.<sup>7</sup>

Several sources of data indicate that ULNB's are capable of achieving lower NO<sub>x</sub> emission levels than LNB's. Emission levels for NO<sub>x</sub> reported by one refinery using ULNB's, shown in Appendix C, range from 0.050 to 0.031 lb/MMBtu.<sup>14</sup> Controlled NO<sub>x</sub> emissions of 0.025 lb/MMBtu have been reported for the Selas ULNx<sup>®</sup> burner.<sup>15</sup> This emission level is reported for natural gas firing and a firebox temperature of 1250°C (2280°F). In a heater firing refinery fuel-gas using an Exxon proprietary staged-air burner incorporating IFGR, NO<sub>x</sub> emission levels of 55 ppmv at 3 percent O<sub>2</sub> (0.066 lb/MMBtu) at 273°C (524°F) preheat are anticipated.<sup>16</sup> Operating under different firebox conditions than the Exxon burner, the John Zink NDR burner for ND heaters was designed to meet SCAQMD Rule 1109 emissions (0.03 lb/MMBtu or 25 to 28 ppmv depending on fuel composition).<sup>17</sup> Additional

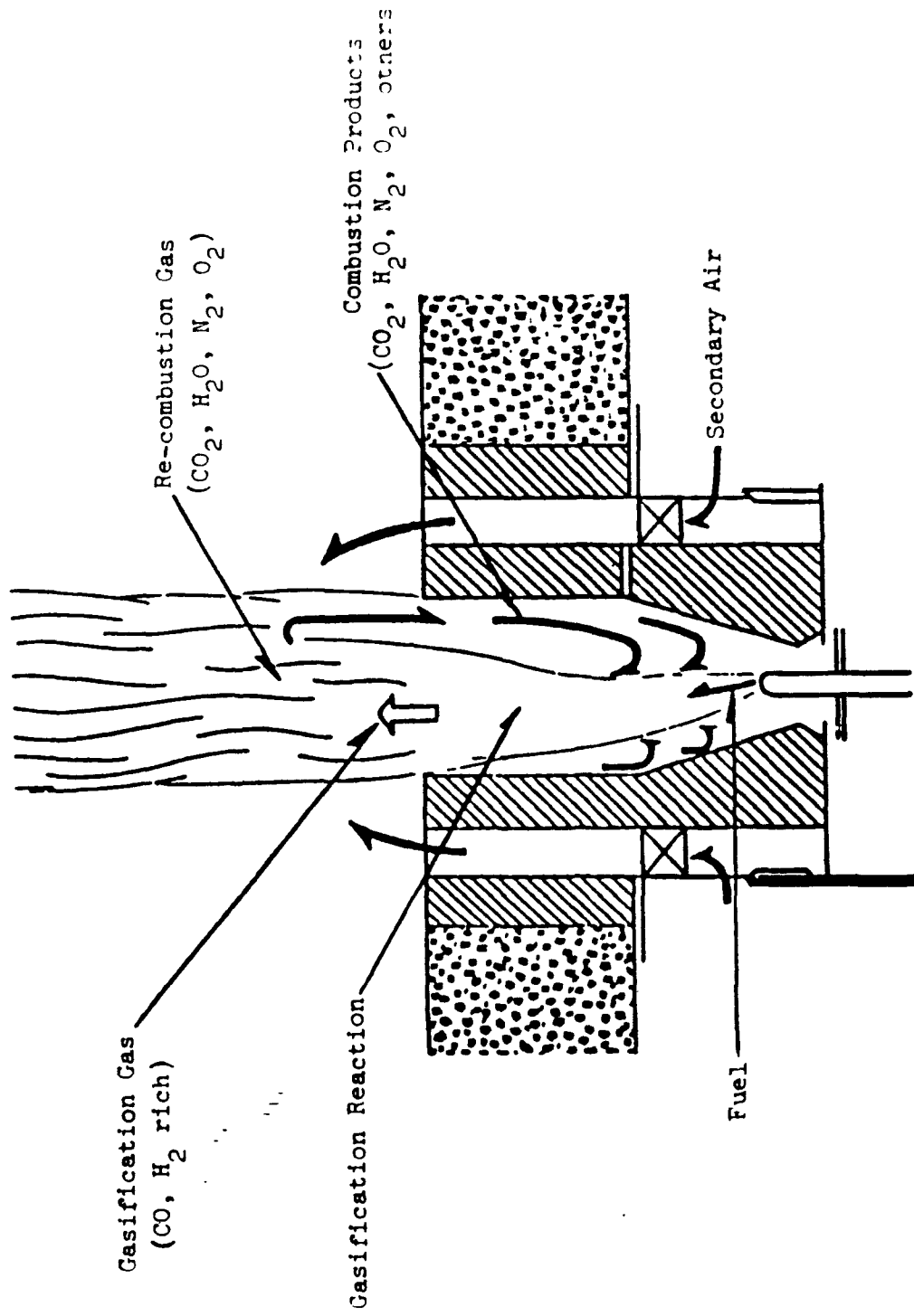

Figure 5-5. Cross-section of an internal flue gas recirculation burner. 1

reductions of 5 to 10 ppmv appear achievable with approximately 0.12 lb steam/lb fuel injection.<sup>17</sup>

Refinery retrofit experience shows an average reduction efficiency of 75 percent thermal NO<sub>x</sub> reduction for ULNB's.<sup>14</sup> Supporting this performance, the Callidus LE-CSG burner is reported to achieve a NO<sub>x</sub> reduction efficiency of approximately 75 to 80 percent.<sup>9</sup> The manufacturer states that this IFGR ULNB can achieve this reduction firing natural gas with ND or MD (preheat) operation. Based on available oil-fired process heater data, fuel NO<sub>x</sub> reductions of 78 percent for ND and 72 percent for MD (preheat) are achievable by ULNB's.<sup>7</sup> Therefore, the reduction efficiencies used in this study for ULNB's for low- and medium-temperature process heaters are 75 percent for thermal NO<sub>x</sub>, 78 percent for ND fuel NO<sub>x</sub> and 72 percent for MD (preheat) fuel NO<sub>x</sub>.

Retrofit problems with ULNB's are similar to those encountered with LNB retrofits. Ultra-low-NO<sub>x</sub> burners, in general, are larger in size and may require larger air plenums than do conventional burners. Modifications to the burner mounts may be required because ULNB's usually do not fit into conventional burner mounts. However, one manufacturer has addressed this problem for wall-fired burners. It is reported that this manufacturer's latest generation ULNB is designed to fit into other burner mounts without major wall modifications.<sup>15</sup> It is expected that this may not always be true because of the wide variety of burners available and the differing heater designs.

#### 5.1.8 Radiant Burners

Alzeta offers a gas burner that has a cube of ceramic fibers at the burner tip. The fibers act as a catalyst in oxidizing the fuel. As a result, combustion is accomplished at a temperature of approximately 980°C (1800°F).<sup>7</sup> Thermal NO<sub>x</sub> formation is reduced since this temperature is approximately 1000°C (1830°F) lower than is generated in conventional burners. Radiant burners do not appear to be affected by high-temperature air preheat, and NO<sub>x</sub> is actually decreased by high excess-air operation.<sup>18</sup> This



technique is available for new installations but is not considered practical in most cases for retrofit installation. The burner intrudes into the furnace space, and a retrofit would probably require retubing the process heater. Reported emissions have been 20 to 25 ppmv at 3 percent O<sub>2</sub> (0.024 to 0.030 lb/MMBtu) of NO<sub>x</sub>.<sup>18,19</sup> Table 5-6 presents data from three different radiant burner process heater applications. The first application is for a natural gas-fired model 6 MMBtu/hr heater operated at three different capacity factors. Emission data are shown for the heater using MD conventional burners and for the heater using radiant burners. The NO<sub>x</sub> emissions from the heater using radiant burners were approximately 75 percent less than those from the heater using MD conventional burners. Controlled NO<sub>x</sub> emission levels of 20 ppmv at 3 percent O<sub>2</sub> (0.024 lb/MMBtu) were reported by the burner vendor.<sup>20,21</sup> The second and third applications are retrofits of two 8 MMBtu/hr heaters. Data are shown for each heater operated at two different capacity factors. Data for preretrofit NO<sub>x</sub> emissions were not available. The postretrofit NO<sub>x</sub> emissions ranged from 0.0 ppmv at 3 percent O<sub>2</sub> to 15.7 ppmv at 3 percent O<sub>2</sub> (0.0 to 0.019 lb/MMBtu).<sup>20,21</sup>

Reported problems with the ceramic burners include fouling, fragility, and somewhat limited capacities.<sup>7</sup> The heater capacity, efficiency, and radiant section heat absorption may be affected in retrofit applications because radiant burners operate at lower temperatures than conventional burners.<sup>5</sup>

## 5.2 SELECTIVE NONCATALYTIC REDUCTION

Selective noncatalytic reduction (SNCR) involves the direct injection of a NO<sub>x</sub>-reducing chemicals into the hot flue gas. At suitably high temperatures, the injected chemical can convert the NO<sub>x</sub> to N<sub>2</sub> without a catalyst.<sup>7</sup> Currently there are three chemical reactants that are available for the SNCR process: anhydrous ammonia (NH<sub>3</sub>), aqueous NH<sub>3</sub>, and aqueous urea solution. Other chemicals such as hydrogen, hydrogen peroxide, and methanol may be added to improve performance and lower the minimum

TABLE 5-6. RADIANT BURNER APPLICATIONS<sup>20, 21</sup>

ID No.	Capacity, heat absorbed, MMBtu/hr	Energy input, MMBtu/hr		Capacity factor	Conventional MD burner NO <sub>x</sub> emissions, ppmv @ 3% O <sub>2</sub>	Conventional MD burner NO <sub>x</sub> emissions, lb/MMBtu input	Radiant burner NO <sub>x</sub> emissions, ppmv @ 3% O <sub>2</sub>	Radiant burner NO <sub>x</sub> emissions, lb/MMBtu input
		MD heater w/ conventional burners	Heater w/ radiant burners					
1	6.0 <sup>a</sup>	7.50	7.50	0.90	80.0	0.097	20.0	0.024
2	6.0	8.28	7.50	0.50	80.0	0.097	20.0	0.024
3	6.0	8.28	7.50	0.30	80.0	0.097	20.0	0.024
4	8.0 <sup>b</sup>	N/A	3.80	0.48	N/A	N/A	12.1	0.014
5	8.0	N/A	7.80	0.98	N/A	N/A	15.7	0.019
6	8.0 <sup>c</sup>	N/A	3.90	0.49	N/A	N/A	0.0	0.0
7	8.0	N/A	8.20	1.02	N/A	N/A	10.7	0.013

<sup>a</sup>Heaters numbers 1 through 3 are the same heater operated at different capacity factors. These heaters were modeled heater applications provided by Alzeta.

<sup>b</sup>Heaters numbers 4 and 5 are the same heater operated at different capacity factors.

<sup>c</sup>Heaters numbers 6 and 7 are the same heater operated at different capacity factors.

N/A = Data not available.

threshold temperature.<sup>22</sup> The SNCR reduces both thermal and fuel-derived NO<sub>x</sub>.

Development is continuing on new NO<sub>x</sub>-reducing agents for use in SNCR applications on boilers and fired heaters. In particular, development is focused on extending the lower threshold temperature at which the reaction can occur and controlling emissions of unreacted reactants, or reactant slip.

The injection point is determined by the allowable temperature "window" required to carry out the reaction. The upper limit for all SNCR processes is about 1100°C (2000°F). Provided that the heater bridgewall temperature is below this threshold temperature, the chemicals are injected via compressed air or low-pressure steam into the firebox. Above 1100°C (2000°F) bridgewall temperatures, the chemicals can be injected into the appropriate section of the convection bank. This latter option is common in large utility boilers.

Heaters can be retrofitted for SNCR by installing injection nozzles through holes cut in the furnace wall. The nozzles are connected by piping to air or steam and chemical supplies. Bulk chemical storage is normally remote from the individual heater and can be used for more than one heater or boiler.

The SNCR systems require rapid chemical diffusion in the flue gas. The injection point must be selected to ensure adequate flue gas residence time and to avoid tube impingement. Computer modeling provided by the licensor can be used to develop the optimum injection points.

Ammonia slip is potentially higher in SNCR systems than in SCR systems because the chemical reactant injection ratios in SNCR systems are higher. Heater load variations, such as startups, shutdowns, and major upsets in heater operation, tend to change the firebox temperature. These variations can affect NO<sub>x</sub> reduction and NH<sub>3</sub> slip when operating near the extremes of the allowable temperature window. Ammonia slip can be minimized by properly designed control systems that monitor the flue gas on a continuous or frequent basis for heater load and NO<sub>x</sub> concentration.<sup>23</sup>

Ammonia slip can also cause ammonium sulfate  $[(\text{NH}_4)_2\text{SO}_4]$  deposits in the convection section. These deposits can occur if sulfur trioxide ( $\text{SO}_3$ ) is present in the flue gas.<sup>7</sup>

Postcombustion controls such as SNCR may be used as the sole  $\text{NO}_x$  control technique or in combination with LNB's. Potential  $\text{NO}_x$  reduction efficiency for SNCR is approximately 70 percent, but controlled emission levels at existing installations show similar  $\text{NO}_x$  reductions for either SNCR or LNB's plus SNCR. This is likely because the controlled emission levels reflect permit requirements. It is expected that achievable  $\text{NO}_x$  reductions using LNB's plus SNCR are greater than the reductions achieved by using SNCR.<sup>5</sup>

Selective noncatalytic reduction efficiency is dependent on the  $\text{NO}_x$  concentration in the flue gas. Therefore, it is expected that SNCR used on a heater with relatively high uncontrolled  $\text{NO}_x$  emissions will have a higher reduction efficiency than an SNCR used on a heater with relatively low uncontrolled  $\text{NO}_x$  emissions. This also indicates that for any particular heater the performance of SNCR used in combination with LNB may have a lower reduction efficiency than if SNCR was used alone.<sup>5</sup>

#### 5.2.1 Exxon Thermal De $\text{NO}_x$ <sup>®</sup> (Ammonia Injection)

Thermal De $\text{NO}_x$ <sup>®</sup> (TDN), developed by Exxon, is an add-on  $\text{NO}_x$  control technique that reduces  $\text{NO}_x$  to  $\text{N}_2$  and water ( $\text{H}_2\text{O}$ ) without the use of a catalyst. Figure 5-6 shows a process flow diagram for a TDN system applied to a process heater.<sup>22</sup> The TDN process injects anhydrous or aqueous  $\text{NH}_3$  to react with  $\text{NO}_x$  in the air-rich flue gas. The  $\text{NH}_3$ -to- $\text{NO}_x$  injection ratio is generally between 1:1 and 2:1 for the TDN process. Equation 1 shows the reaction with a 1:1 ratio, and Equation 2 shows the reaction with a 2:1 ratio.

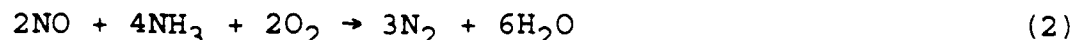
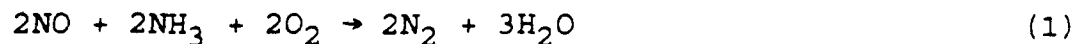

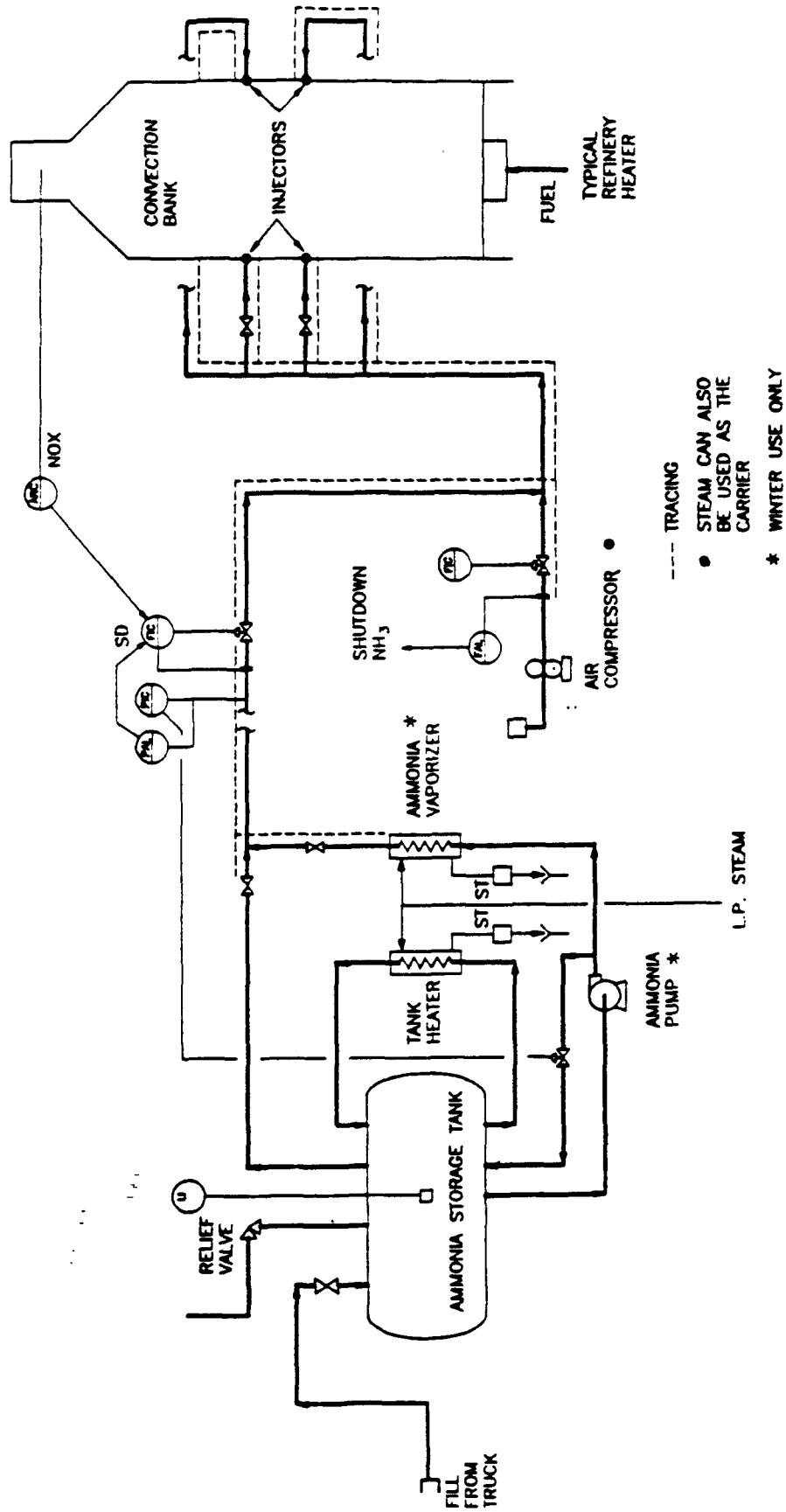
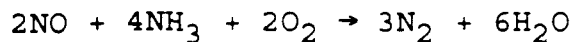

Figure 5-6. Exxon Thermal DeNO<sub>x</sub>® system. 7

Using a 2:1 injection ratio, the  $\text{NH}_3$  and  $\text{NO}_x$  react according to the following competing reactions:<sup>10</sup>



5.2.1.1 Process Description (Thermal DeNO<sub>x</sub><sup>®</sup>). This process has been installed in 75 process heater and nonprocess heater applications, and 22 more are presently under design or construction.<sup>7</sup> Table 5-7 presents a partial list of Exxon's Thermal DeNO<sub>x</sub><sup>®</sup> process heater installations and NO<sub>x</sub> control performance.<sup>7,24</sup> The reactant is mixed with low-pressure air from a separate air compressor before passing into the top of the firebox through a number of injection nozzles (or into the convection bank if the bridgewall temperature is above 1100°C [2000°F]). The allowable temperature "window" for the reaction to proceed is 870° to 1100°C (1600° to 2000°F).<sup>7</sup>

Thermal DeNO<sub>x</sub><sup>®</sup> systems may either use aqueous or anhydrous  $\text{NH}_3$ . The  $\text{NH}_3$  in an aqueous solution is at a lower concentration than in an anhydrous solution and therefore has reduced safety concerns. For this reason, aqueous  $\text{NH}_3$  is often used at sites in close proximity to populated areas. However, refineries are generally experienced in handling anhydrous  $\text{NH}_3$ , and no particularly troublesome operational problems are foreseen. Location of pressurized anhydrous  $\text{NH}_3$  storage tanks should be remote from the heaters served and from other facilities.<sup>7</sup> Further discussion of issues relating to  $\text{NH}_3$  is included in Section 7.1.2.2.

Hydrogen may be added to the  $\text{NH}_3$  to extend the allowable minimum operating temperature from 760° to 700°C (1400° to 1300°F).<sup>5</sup> This  $\text{H}_2$  can be supplied from  $\text{H}_2$ -rich refinery streams such as catalytic reformer off-gas. Alternately, the  $\text{H}_2$  can be supplied by an electrically heated  $\text{NH}_3$  dissociator, which converts a portion of the  $\text{NH}_3$  to  $\text{H}_2$  and  $\text{N}_2$ . This approach may be preferable from a safety standpoint, but  $\text{H}_2$ -rich gas is less

TABLE 5-7. PARTIAL LIST OF EXXON'S THERMAL  
DeNO<sub>x</sub> INSTALLATIONS<sup>7, 24</sup>

Installation date	Fuel	Size, MW (MMBtu/hr)	Uncontrolled NO <sub>x</sub> , ppmv at 3 percent O <sub>2</sub> <sup>a</sup>	Controlled NO <sub>x</sub> , ppmv at 3 percent O <sub>2</sub> <sup>a</sup>	Percent reduction
1975	Gas	151 (515)	130	48	63
1975	Gas/oil	57 (190)	130	48	63
1977	Gas/oil	73 (250)	79	39	51
1977	Gas/oil	73 (250)	85	40	53
1980	Gas/oil	12 (41)	80-165	40-83	50
1980	Gas/oil	13 (44)	80-165	28-58	65
1980	Gas	31 (105)	80-165	38-78	53
1980	Gas	4 (13)	80-165	40-83	50
1980	Gas	19 (65)	80-165	31-64	61
1980	Gas	14 (49)	80-165	40-83	50
1980	Gas	38 (130)	80-165	48-99	40
1980	Gas	8 (27)	80-165	40-83	50
1980	Gas	4 (13)	80-165	54-111	33
1980	Gas	6 (19)	80-165	48-99	40
1980	Gas	10 (35)	80-165	27-56	66
1980	Gas	22 (74)	80-165	28-58	65
1980	Gas	9 (32)	80-165	36-90	55
1980	Gas	7 (25)	100-150	50-75	50
1980	Gas	30 (102)	100-150	50-75	50
1980	Gas	7 (25)	100-150	50-75	50
1980	Gas	49 (167)	100-150	50-75	70
1981	NA	9 (32)	120	65	45
1981	NA	4 (15)	120	42	65
1982	NA	27 (92)	80-125	NA	30-60
1982	NA	8 (28)	80-125	NA	30-60
1982	NA	7 (23)	80-125	NA	30-60
1982	NA	7 (23)	80-125	NA	30-60
1981	Gas	38 (131)	75	38	49
1985	Gas	92 (315)	144	45	69
1991	Oil	7 (23)	70	40	43

<sup>a</sup>NO<sub>x</sub> (lb/MMBtu) = NO<sub>x</sub> (ppmv @ 3% O<sub>2</sub>) \* 0.001194 for gas.

NO<sub>x</sub> (lb/MMBtu) = NO<sub>x</sub> (ppmv @ 3% O<sub>2</sub>) \* 0.001260 for oil.

NA = Not available

expensive and should be acceptable when used with adequate safeguards.

#### 5.2.1.2 Factors Affecting Thermal DeNO<sub>x</sub><sup>®</sup> Performance.

Temperature is the primary variable for controlling the selective reaction. The first reaction (Equation 1) dominates in the temperature range of 870° to 1200°C (1600° to 2200°F), resulting in a reduction of NO<sub>x</sub>.<sup>8</sup> The temperature range can be lowered to 760° (1400°F) by adding H<sub>2</sub>, a readily oxidizable gas, to the reactant.<sup>5</sup> Below 760°C (1400°F), neither reaction is of sufficient activity to either produce or destroy NO<sub>x</sub>; the result will be unreacted NH<sub>3</sub>, or NH<sub>3</sub> slip. Above 1200°C (2200°F), the second reaction (Equation 2) dominates, causing increased NO<sub>x</sub> production.

Without the use of a catalyst to increase the reaction rates, adequate time at optimum temperatures must be available for the NO<sub>x</sub> reduction reaction to occur. Design considerations should allow ample residence time and good mixing in the required temperature range. Long residence times (>1 second) at optimum temperatures tend to promote relatively high NO<sub>x</sub> reduction performance even with less-than-optimum initial mixing or temperature/velocity gradients. However, when the NH<sub>3</sub> injection zone is characterized by low temperatures and/or steep temperature declines, a loss of process efficiency results.

New process heater installations can incorporate the location of the SNCR injection points in the design of the heater, but retrofit performance may be limited by the accessibility of a location with a suitable temperature window for the SNCR injection points.

The ratio of NH<sub>3</sub>:NO<sub>x</sub> is another parameter used to control the process. The NH<sub>3</sub>:NO<sub>x</sub> ratio is typically from 1.0 to 1.5, but can be as high as 2.0 when injection is into a high flue gas temperature region. The ratio must be consistent with the flue gas temperature and residence time so that the maximum reduction is obtained with acceptable slip. If excessive NH<sub>3</sub> is injected, the excess NH<sub>3</sub> can exit the convective zone, creating possible corrosive (NH<sub>4</sub>)<sub>2</sub>SO<sub>3</sub> and a visible NH<sub>3</sub> stack plume.<sup>1</sup> The



temperatures and velocity profiles change significantly with load. This necessitates the use of multiple  $\text{NH}_3$  injection points to achieve the desired  $\text{NO}_x$  reduction for a range of operating loads. Selection of the optimum  $\text{NH}_3$  injection location also affects  $\text{NO}_x$  reduction performance and  $\text{NH}_3$  slip. In most current Thermal De $\text{NO}_x$ <sup>®</sup> applications, the injection grids are being replaced by wall injectors.<sup>8</sup>

5.2.1.3  $\text{NO}_x$  Reduction Efficiency Using Thermal De $\text{NO}_x$ <sup>®</sup>. Data in Table 5-7 indicate that 30 to 75 percent of the  $\text{NO}_x$  in the flue gas can be removed with the Thermal De $\text{NO}_x$ <sup>®</sup> process. Maximum achievable  $\text{NO}_x$  emission reductions appear to be approximately 70 to 75 percent. However, SNCR systems are usually designed to meet regulatory limits rather than maximum achievable reductions. This explains the wide range of reduction percentages in the data. The average percent reduction in Table 5-7 is approximately 60 percent, which is used in this study to represent the percent reduction by SNCR and to calculate cost-effectiveness values.<sup>7,24</sup>

5.2.1.4 Ammonia Slip Considerations for Thermal De $\text{NO}_x$ <sup>®</sup>. Ammonia slip is unreacted  $\text{NH}_3$  that exits the stack. The molar ratio of the  $\text{NH}_3:\text{NO}_x$  is not only important to achieve the most efficient reduction, but the reduction must be balanced with an acceptable amount of  $\text{NH}_3$  slip. An excessive  $\text{NH}_3:\text{NO}_x$  molar ratio can result in unacceptable  $\text{NH}_3$  slip.

In a typical refinery heater application, the  $\text{NH}_3:\text{NO}_x$  ratio is maintained at about 1.25 to achieve a 70 percent reduction in  $\text{NO}_x$  emissions with  $\text{NH}_3$  slip below 20 ppmv in the stack gas.<sup>7</sup>

#### 5.2.2 Nalco Fuel Tech $\text{NO}_x\text{OUT}$ <sup>®</sup> (Urea Injection)

In the early 1980's, the Electric Power Research Institute (EPRI) developed a urea- $(\text{CO}(\text{NH}_2)_2)$  based SNCR process with an 870° to 1100°C (1600° to 2000°F) allowable operating temperature window.<sup>7</sup> While Nalco Fuel Tech is EPRI's exclusive licensing agent in the United States, Noell KRC and affiliated companies are using the process in Europe.<sup>23</sup> Nalco Fuel Tech promotes the use of other chemicals to extend the temperature range and control  $\text{NH}_3$  slippage to very low levels. Currently, the urea

injection process has been installed on four process heaters. Most of the current applications are on coal-, oil-, and gas-fired boiler applications. A summary of current and pending urea-based injection applications is provided in Appendix B.

5.2.2.1 Process Description (NO<sub>x</sub>OUT®). Figure 5-7 shows a typical arrangement and major components of the NO<sub>x</sub>OUT® process.<sup>7</sup> The process, as originally developed, involves direct injection of an aqueous urea solution using air or steam to assist its distribution in the firebox or convection bank. Nalco Fuel Tech reports that the higher momentum associated with injecting nonvolatile solutions requires less energy to obtain good distribution than is needed with the anhydrous Thermal DeNO<sub>x</sub>® process. Available data, however, suggest that because of the use of nonvolatile solutions, it appears that more energy is needed to obtain good distribution than is required with the anhydrous Thermal DeNO<sub>x</sub>® process.<sup>7</sup>

In the urea injection SNCR process, urea is injected into the combustion gas path. In the ensuing reaction, molecules of NO are converted to N<sub>2</sub>, H<sub>2</sub>O, and CO<sub>2</sub>. The desired chemical reaction is:

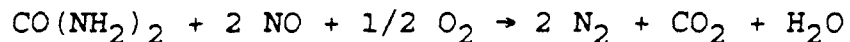

The above chemical reaction indicates that 1 mole of urea reacts with 2 moles of NO. However, greater-than-stoichiometric quantities of urea can be injected to improve NO<sub>x</sub> reduction and to speed the reaction kinetics. This can result in some NH<sub>3</sub> slippage and a slight increase in CO; both are generated as byproducts from the incomplete thermal decomposition of the excess urea.<sup>7</sup>

Nalco Fuel Tech has modified the original process in order to reduce the minimum allowable temperature from 870°C (1600°F) to as low as 650°C (1200°F) by adding of a variety of nonhazardous chemicals, which include antifouling and storage stabilizing agents. In a refinement of the process, different chemical blends may be added at two different flue gas temperature levels. More than one chemical package may be needed in cases where several heaters or boilers are involved, having

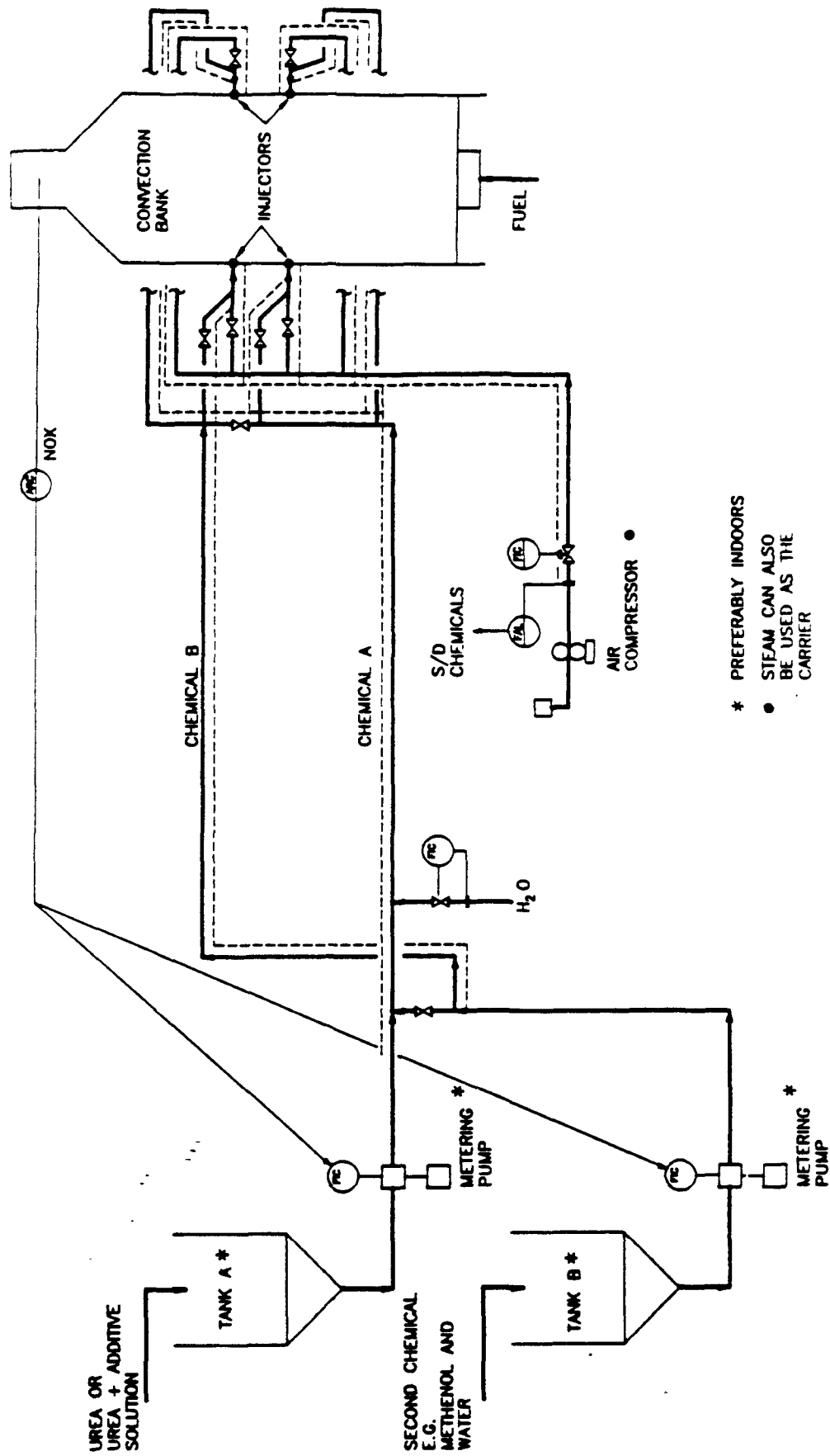

- \* PREFERABLY INDOORS
- STEAM CAN ALSO BE USED AS THE CARRIER

Figure 5-7. Nalco Fuel Tech NO<sub>x</sub>OUT<sup>®</sup> -type NO<sub>x</sub> reduction system. 7

large variations in firebox temperature. If the firebox temperature is over 600°C (1110°F), injection can be downstream of the shock tubes.<sup>7</sup>

Nalco Fuel Tech has licensed urea producers to blend and sell NO<sub>x</sub>OUT<sup>®</sup> chemical packages containing the necessary additives. For new, larger applications, the urea-based solutions can be prepared onsite from solid chemicals delivered via bulk transport. Very small users can be supplied with predissolved solutions. The stored chemicals are further diluted before being pumped to the heater/boiler for injection using steam or compressed air as the carrying medium. The number of injection nozzles may be similar to or greater than those used for NH<sub>3</sub>.<sup>7</sup> However, Nalco Fuel Tech indicates that the number of injection nozzles will be less than for NH<sub>3</sub> injection.<sup>23</sup> For either NH<sub>3</sub>- or urea-based processes, the number of injection nozzles will be site specific.

Since an aqueous solution and distribution air are added to the firebox flue gas, there will be a heat duty loss of approximately 0.3 percent in the convection section, which results in increased fuel consumption.

5.2.2.2 Factors Affecting NO<sub>x</sub>OUT<sup>®</sup> Performance. As with ammonia injection, the primary factor that influences the reduction reaction rate is temperature. The temperature window for efficient reduction is 870° to 1150°C (1600° to 2100°F), although H<sub>2</sub> and CO injection have been shown to lower the temperature window. Residence time and the mixing of the urea-based reagent and NO<sub>x</sub> also influence the reduction reaction. The molar ratio of urea to NO<sub>x</sub> is similar to the Thermal DeNO<sub>x</sub><sup>®</sup> molar ratio. A low molar ratio reduces the potential reaction, but a high molar ratio can result in NH<sub>3</sub> slip.<sup>7,8</sup>

Because sufficient residence time within the temperature window is necessary for efficient NO<sub>x</sub> reduction, the injection point of the urea-based reagent is important. Usually, the injection point is prior to the convective heat recovery section. Load variations affect the flue gas temperature and velocity, thereby affecting the residence time. At reduced loads, the

temperature window may not be reached, resulting in a reduction in NO<sub>x</sub> efficiency and an increase in NH<sub>3</sub> slip.<sup>1</sup> A solution to this problem is the use of additives in the urea solution to shift or widen the temperature window. One study shows that additives such as carbon monoxide, methane, and ethylene glycol, or a combination of these, increase NO<sub>x</sub> reduction by decreasing temperature dependence. The study also concludes that the initial NO<sub>x</sub> concentrations apparently have some bearing on NO<sub>x</sub>OUT<sup>®</sup> performance and the selection of additives.<sup>25,27</sup>

5.2.2.3 NO<sub>x</sub> Emission Reduction Efficiency Using NO<sub>x</sub>OUT<sup>®</sup>. Applications of the NO<sub>x</sub>OUT<sup>®</sup> process on process heaters are limited. However, as shown in Appendix B, boiler applications of the process have been successful, and it appears that NO<sub>x</sub>OUT<sup>®</sup> is a viable alternative control technique. As shown in Table 5-8, NO<sub>x</sub> emission reductions guaranteed by the vendor for process heaters range from 10 to 75 percent.<sup>26</sup> The NO<sub>x</sub>OUT<sup>®</sup> performance appears to be similar to the performance of Thermal DeNO<sub>x</sub><sup>®</sup>, with average NO<sub>x</sub> reductions for process heater applications of approximately 60 percent.

5.2.2.4 Ammonia Slip Considerations for NO<sub>x</sub>OUT<sup>®</sup>. Unreacted urea results in NH<sub>3</sub> slip in a manner similar to ammonia slip from the Thermal DeNO<sub>x</sub><sup>®</sup> process. Slippages of 10 to 20 ppmv have been reported.<sup>7,8</sup>

### 5.3 SELECTIVE CATALYTIC REDUCTION

In the SCR process, a small amount of anhydrous or aqueous ammonia (NH<sub>3</sub>) vapor is mixed with flue gas and passes through a catalytic reactor so that the NO<sub>x</sub> (mainly NO) is reduced to N<sub>2</sub>. A wide variety of available catalysts can operate at flue gas temperature windows ranging from 230° to 600°C (500° to 1100°F), which usually occur downstream of the fire box.

The SCR systems introduce flue gas pressure drops ranging from 23 to 130 mm w.g. (1 in. to 5 in.) that necessitate a new or replacement induced draft (ID) fan for all heaters. Also, SCR retrofits require appreciable plot space adjacent to the heater. Currently, SCR has been demonstrated on some but not all types of process heaters.<sup>27</sup> This is not only because permit limits have

TABLE 5-8. NALCO FUEL TECH NO<sub>x</sub>OUT<sup>®</sup> PROCESS  
HEATER APPLICATIONS<sup>2,3</sup>

Capacity, MMBtu/hr	Baseline emissions		Reduction guaranteed by vendor, percent	Controlled emissions	
	ppm <sup>a</sup>	lb/MMBtu		ppm <sup>a</sup>	(lb/MMBtu)
177	38-50	0.045-0.060	35-60	15.2-32.5	0.018-0.039
50	65	0.078	50-75	16.3-32.5	0.020-0.039
NA	90	0.107	55	40.5	0.048
NA	30-50	0.038-0.063	10	27-45	0.034-0.057

<sup>a</sup>At 3 percent excess O<sub>2</sub>.

NA = Not available.

been achieved by the use of other control techniques, but because SCR requires controlled parameters such as sufficient residence time in the correct temperature window. Where applicable, SCR offers the highest percent reductions of the available NO<sub>x</sub> reduction techniques.

### 5.3.1 Process Description (SCR)

In this process, NH<sub>3</sub>, usually diluted with air or steam, is injected through a grid system into the flue/exhaust gas upstream of a catalyst bed. On the catalyst surface, the NH<sub>3</sub> reacts with NO<sub>x</sub> to form N<sub>2</sub> and H<sub>2</sub>O.<sup>7,8</sup> The major reactions that occur in the presence of the catalyst are the following:

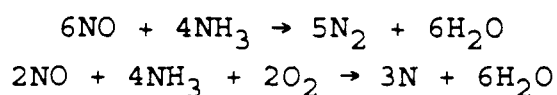

Figure 5-8 shows major components and control systems associated with an SCR retrofit using a horizontal reactor. Horizontal and vertical arrangements of the SCR reactor catalyst chamber are both acceptable, but vertical arrangements use less space and hence are more common in process plants. Vertical reactors can be downflow or upflow, with downflow preferable, as particulate matter tends to drop through the catalyst. The heater ID fan can be located at either the inlet or outlet of the reactor containing the catalyst bed.<sup>7,28</sup>

Ammonia vapor is injected into the flue gas through a special distributor located upstream of the reactor using compressed air to distribute the reactant evenly. This distribution air is delivered at about 21 to 35 kilopascals (kPa) (3 to 5 gage pounds per square inch [psig]) using a lobe-type air compressor at a rate equivalent to about 30 times the NH<sub>3</sub> rate. Ideally, NH<sub>3</sub> injection is controlled via a stack gas NO<sub>x</sub> analyzer, but control via fuel flow is also satisfactory for many refinery applications provided that stack gas is analyzed regularly.<sup>7,28</sup>

The reactor is located upstream of air preheaters, if present, so as to maintain the optimal reactor inlet temperature. In ND heater retrofits, the existing stack is removed, although

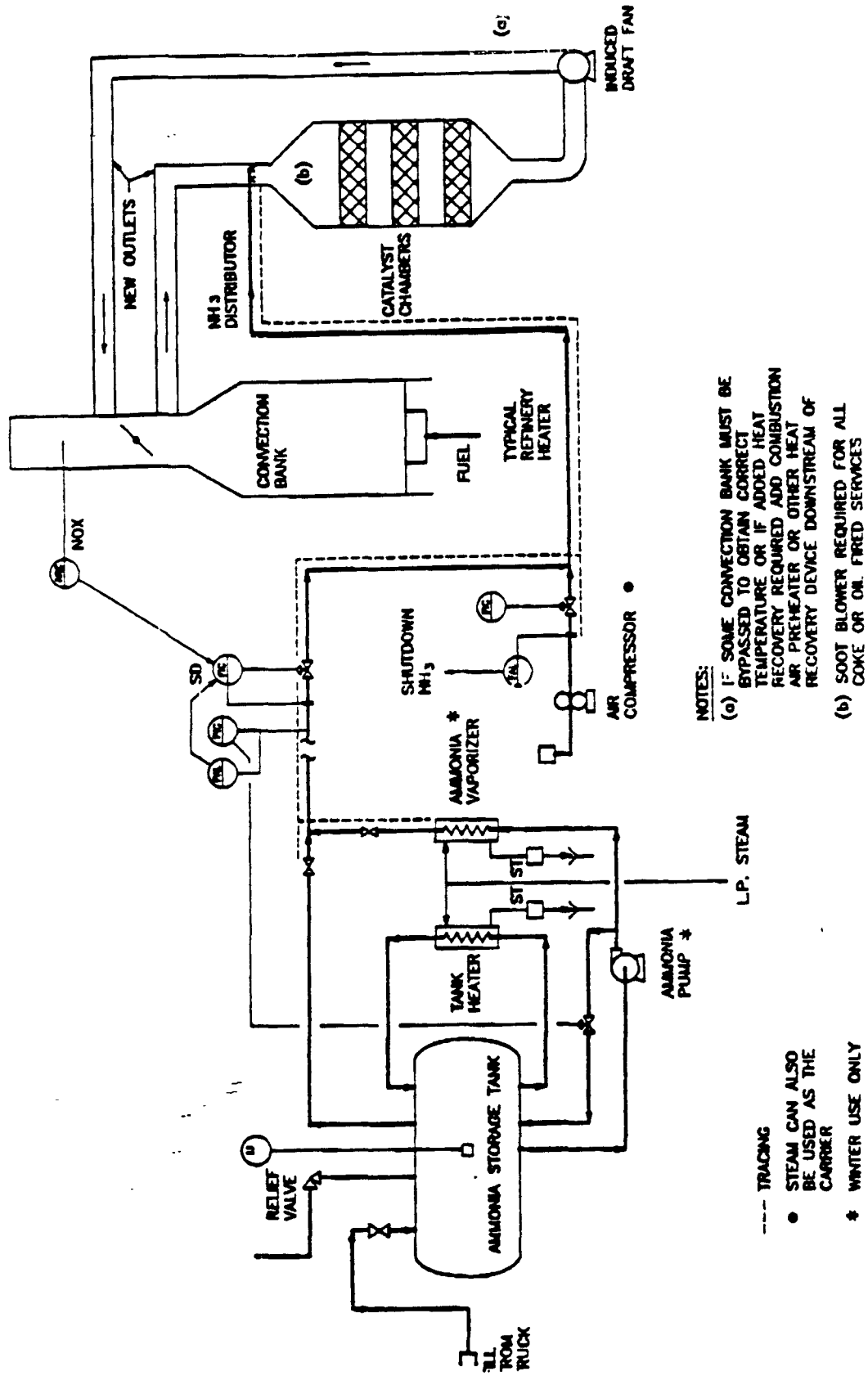

Figure 5-8. Schematic of a selective catalytic reduction system. 7



possibly a portion can be reused. Ductwork to and from the reactor is at least as large as the existing stack.

Only one ID fan is necessary and a fail-safe stack damper is needed to open automatically on either fan failure and/or any excess pressure in the furnace itself. The fan drive may be variable-speed to minimize horsepower requirements.

Reactor soot blowers are needed in oil-fired applications to keep the catalyst surface clean of soot and loose ash. The system downstream must take soot blowing into account. The catalyst is contained in special baskets or frames for insertion and removal. This arrangement requires sufficient free area beside each reactor for cranes as well as for the catalyst modules.

A typical 100 GJ/hr (100 MMBtu/hr) furnace application requires a 4 x 5 m (13.1 x 16.4 ft) plot for the reactor itself plus approximately 6 m (19.7 ft) to one side for catalyst removal and replacement.<sup>7</sup>

### 5.3.2 Factors Affecting SCR Performance

The reaction of  $\text{NH}_3$  and  $\text{NO}_x$  is favored by the presence of excess  $\text{O}_2$  (air-rich conditions), but the primary variable affecting  $\text{NO}_x$  reduction is temperature.<sup>8</sup> Optimum  $\text{NO}_x$  reduction occurs at catalyst bed temperatures of 320° to 400°C (600°F to 750°F) for conventional (vanadium- or titanium-based) catalyst types and 243° to 265°C (470° to 510°F) for platinum catalysts.<sup>7,28</sup> Performance for a given catalyst depends largely on the temperature of the flue gas being treated (see Figure 5-9). A given catalyst exhibits optimum performance within  $\pm 10^\circ\text{C}$  ( $\pm 50^\circ\text{F}$ ) of its design temperature for applications in which flue gas  $\text{O}_2$  concentrations are greater than 1 percent. Below this optimum temperature range, the catalyst activity is greatly reduced, allowing unreacted  $\text{NH}_3$  to slip through. Above 450°C (850°F), ammonia begins to oxidize to form additional  $\text{NO}_x$ . The  $\text{NH}_3$  oxidation to  $\text{NO}_x$  increases with increasing temperature. Depending on the catalyst substrate material, the catalyst may be quickly damaged due to thermal stress at temperatures in excess of 450°C (850°F). It is important, therefore, to have stable

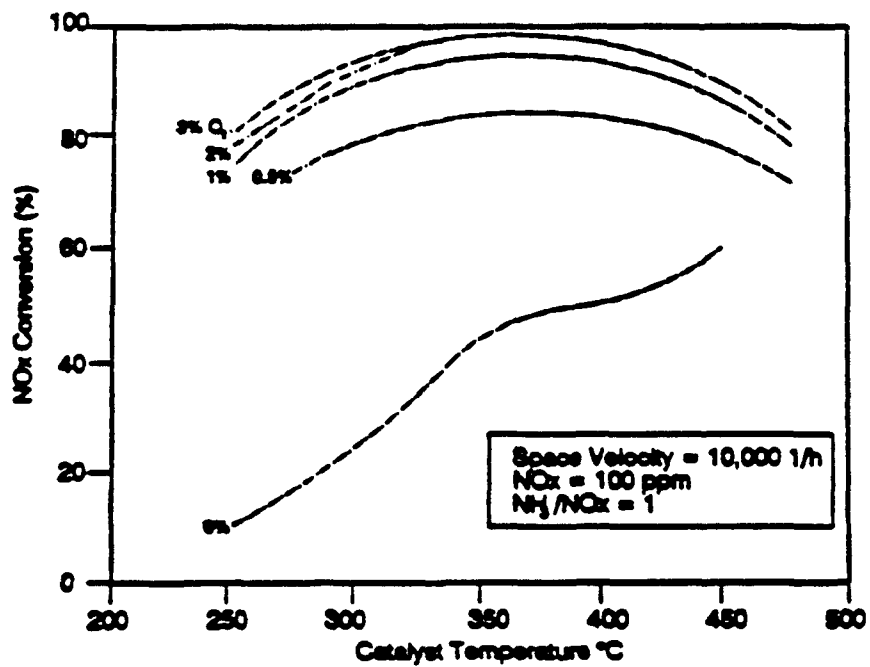

Figure 5-9. Effect of temperature and oxygen on NO<sub>x</sub> conversion.<sup>6</sup>

operations and thus uniform flue gas temperatures within the optimum temperature range for this process to achieve optimum NO<sub>x</sub> control. New process heater installations can accommodate the location of the reactant injector points and catalyst in the design of the heater, but retrofit applications may be limited by the location of a suitable temperature window.<sup>7,28</sup>

A new family of zeolite catalysts has been developed that is capable of functioning at higher temperatures than conventional catalysts.<sup>7</sup> Zeolites are reported to be effective over the range of 320° to 600°C (600° to 1130°F), with the optimum temperature range stated as 360° to 580°C (675° to 1080°F).<sup>7</sup> In some zeolite catalyst formulations, NH<sub>3</sub> oxidation to NO<sub>x</sub> begins at around 450°C (850°F) and is predominant at temperatures in excess of 520°C (960°F).<sup>7</sup> A gas turbine zeolite catalyst installation is reported to be operating in the temperature range of 500° to 520°C (930° to 960°F).<sup>11</sup> The performance is reported to be 80 percent NO<sub>x</sub> reduction with NH<sub>3</sub> slip limit of 20 ppmv at 15 percent O<sub>2</sub> (61 ppmv at 3 percent O<sub>2</sub>).<sup>11</sup> No process heater data were available. Although within the operating range, the zeolite structure may be irreversibly degraded at around 550°C (1020°F) due to loss of pore density. Zeolites suffer the same performance and potential damage problems as conventional catalysts when used outside their optimum temperature range.

With zeolite catalysts, the NO<sub>x</sub> reduction reaction takes place inside a molecular sieve ceramic body rather than on the surface of a metallic catalyst. This difference is reported to reduce the effect of particulate matter/soot, sulfur dioxide (SO<sub>2</sub>)/SO<sub>3</sub> conversion, and/or heavy metals which poison, plug, and mask metal-type catalysts. These catalysts have been in use in Europe since the mid-1980's, with approximately 100 installations onstream. Process applications range from gas to coal fuel. Typically, NO<sub>x</sub> levels are reduced 80 to 90 percent using zeolite catalysts. Zeolite catalysts are currently being purchased for U.S. installations.

The optimal effectiveness of the catalytic process also depends on the NH<sub>3</sub>:NO<sub>x</sub> molar ratio. Ammonia injection rates must

be controlled to give a 1:1  $\text{NH}_3:\text{NO}_x$  molar ratio. As the molar ratio of  $\text{NH}_3:\text{NO}_x$  increases to approximately 1:1, the  $\text{NO}_x$  reduction increases. Operating above a 1:1 ratio with insufficient catalyst volume results in unreacted  $\text{NH}_3$  slipping through the catalyst bed. Onstream analyzers and quick feedback controls are required to optimize  $\text{NO}_x$  removal and minimize  $\text{NH}_3$  emissions.<sup>7,28</sup>

Another variable that affects  $\text{NO}_x$  reduction is space velocity, which is the ratio of flue gas flow rate to catalyst volume, or the inverse of residence time. For a given catalyst volume, increased flue gas rate decreases the conversion of  $\text{NO}_x$ . Conversely, for a given flue gas flow rate, increased catalyst volume improves the  $\text{NO}_x$  removal effectiveness.

The bulk of catalysts now in refinery service contain titanium and/or vanadium. Older formulations of this type of catalyst tend to convert up to 5 percent of the  $\text{SO}_2$  present to  $\text{SO}_3$ .<sup>7</sup> Conversion of  $\text{SO}_2$  to  $\text{SO}_3$ , in turn, results in the formation and deposition of ammonia salts on relatively cool surfaces. One source reports that newer catalyst formulations using titanium and/or vanadium convert 5 percent or less  $\text{SO}_2$ -to- $\text{SO}_3$ .<sup>28</sup> Catalyst formulations with less than one percent  $\text{SO}_2$ -to- $\text{SO}_3$  conversion rates are available, but the catalysts may have lower reduction efficiencies. As a result, a larger catalyst volume may be required to achieve a given  $\text{NO}_x$  reduction. Zeolite catalysts have an  $\text{SO}_2$ -to- $\text{SO}_3$  conversion rate of about 1 percent.<sup>7</sup>

### 5.3.3 $\text{NO}_x$ Emission Reduction Efficiency Using SCR

Catalyst performance and life are normally designed and guaranteed to suit the specific  $\text{NO}_x$  reduction requirements. Ninety percent  $\text{NO}_x$  reductions are achievable when operating at a stoichiometric  $\text{NH}_3:\text{NO}_x$  molar ratio of 1.0 to 1.05:1 with the exit gas containing about 10 to 20 ppmv  $\text{NH}_3$ . At a sub-stoichiometric ratio of 0.5, about 50 percent  $\text{NO}_x$  reduction is achieved with a  $\text{NH}_3$  slip of less than 10 ppmv.<sup>7</sup>

Selective catalytic reduction is usually used in combination with LNB's. Table 5-9 presents a summary of data from the Mobile Oil refinery in Torrance, California (Appendix C).<sup>14</sup> These data

TABLE 5-9. CONTROLLED EMISSION FACTORS FOR SCR  
 ADDED TO HEATERS WITH LNB'S<sup>14</sup>

Heater capacity, MMBtu/hr	Baseline emission factor		Reduction, percent	Controlled emission level	
	ppmv <sup>a</sup>	lb/MMBtu		ppmv <sup>a</sup>	lb/MMBtu
457	46.9	0.056	64.3	16.8	0.020
161	64.5	0.077	74.1	16.8	0.020
288	73.7	0.088	77.2	16.8	0.020
220	83.8	0.100	80.0	16.8	0.020

<sup>a</sup>ppmv at 3 percent O<sub>2</sub>.

demonstrate reductions achieved by adding SCR to heaters with existing LNB's. The reductions using SCR range from 64.3 to 80 percent. The controlled emissions range from 16.8 to 42 ppmv at 3 percent O<sub>2</sub> (0.020 to 0.050 lb/MMBtu). The average emission reduction for these data is 75 percent, and the average controlled emission level is 16.8 ppmv at 3 percent O<sub>2</sub> (0.020 lb/MMBtu).

Appendix D presents a list of 12 Foster Wheeler process heater SCR installations.<sup>29</sup> One installation was reported using SCR plus LNB. Information regarding what NO<sub>x</sub> emission controls, if any, were used in combination with SCR was not available for the remaining 11 installations. The guaranteed reductions ranged from 47 to 90 percent, corresponding to NH<sub>3</sub>:NO<sub>x</sub> injection ratios ranging from 0.7 to 1.0. The average percent reduction was 70 percent. Ten of the 12 installations had guaranteed maximum NH<sub>3</sub> emissions of 10 ppmv; the remaining installations had guaranteed maximum NH<sub>3</sub> emissions of 5 ppmv and 20 ppmv, respectively. Only two of the installations reported excess O<sub>2</sub> concentrations. Each reported excess O<sub>2</sub> at 3 percent and NH<sub>3</sub> emissions of 10 ppmv; corresponding NO<sub>x</sub> emissions were not reported.<sup>29</sup> One source reports that current SCR technology, as demonstrated in utility boiler applications, is capable of maintaining NH<sub>3</sub> slip concentrations below 5 ppmv.<sup>28</sup>

Selective catalytic reduction can be used as a process heater NO<sub>x</sub> control technique in combination with MD LNB's or as the sole control technique. The data in Appendix C show that SCR is capable of reducing, on average, 75 percent of the NO<sub>x</sub> in the flue gas. The data in Appendix C are more complete (i.e., uncontrolled emissions, preretrofit NO<sub>x</sub> controls, postretrofit NO<sub>x</sub> controls and controlled emissions) than the data in Appendix D. Therefore, Appendix C data are used as the basis for SCR performance. For the purposes of this study, the NO<sub>x</sub> reduction efficiency for SCR used as the sole control technique is 75 percent. For natural gas-fired model heaters using LNB's plus SCR, the thermal NO<sub>x</sub> reduction by LNB's is 50 percent and the postcombustion NO<sub>x</sub> reduction by the SCR is 75 percent. The

total effective reduction for natural gas-fired model heaters using LNB's plus SCR is therefore 88 percent. For oil-fired model heaters using LNB's plus SCR, the thermal NO<sub>x</sub> reduction by LNB's is 50 percent, the fuel NO<sub>x</sub> reduction by the LNB's is 25 percent and the postcombustion NO<sub>x</sub> reduction by the SCR is 75 percent. The total effective reductions for ND oil-fired model heaters using LNB's plus SCR are therefore 86 and 83 percent for distillate and residual oil-firing, respectively. The total effective reduction for the MD oil-fired model heaters using LNB's plus SCR are therefore 92 and 91 for distillate and residual oil-firing, respectively.

#### 5.4 SPECIAL CONSIDERATIONS

In pyrolysis, gaseous hydrocarbons such as ethane, propane, and butane and heavier hydrocarbons such as naphtha feedstocks are converted to olefins such as ethylene and propylene. The basic criteria for pyrolysis furnaces are adequate control of heat flux from inlet to outlet of the tubes, high heat transfer rates at high temperatures, short residence times, and uniform temperature distribution along the tube length. Several designs are available for pyrolysis furnaces. All designs incorporate a firebox operating at temperatures ranging from 1050° to 1250°C (1900° to 2300°F), and most designs use the vertical box heater configuration. As shown in Table 5-10, pyrolysis furnaces use approximately 50 percent of the energy requirements of major fired heater applications in the chemical industries.<sup>1</sup>

Postcombustion control techniques for reducing NO<sub>x</sub> from reduction for olefins pyrolysis furnaces are limited because of convection section designs. Retrofit of SNCR and SCR can be difficult because of limited access to the optimal temperature window location. One source reports that there are no known applications of SNCR and SCR on olefins pyrolysis furnaces.<sup>27</sup> However, it is expected that FGR, SNCR and SCR are practical candidates for new installations. Currently, LNB's and ULNB's are used in olefins pyrolysis furnaces.

Selective noncatalytic reduction retrofit requires considerable convection section reconstruction to allow multiple

TABLE 5-10. ENERGY REQUIREMENTS OF MAJOR FIRED HEATER APPLICATIONS IN THE CHEMICAL INDUSTRY<sup>1</sup>

Chemical	Process	Heater type	Firebox temp., °F	1985 fired heater energy requirement *10 <sup>12</sup> Btu/yr	Percent of known chemical industry heater requirements
<b>Low- and medium-temperature applications</b>					
Benzene	Reformate extraction	Reboiler	700	64.8	9.9
Styrene	Ethylbenzene dehydrogenation	Steam superheater	1500-1600	32.1	4.9
Vinyl chloride monomer	Ethylene dichloride cracking	Cracking furnace	NA	12.6	1.9
P-xylene	Xylene isomerization	Reactor fired preheater	NA	13.0	2.0
Dimethyl terephthalate	Reaction of p-xylene and methanol	Preheater, hot oil furnace	480-540 <sup>a</sup>	11.1	1.7
Butadiene	Butylene dehydrogenation	Preheater, reboiler	1100	2.6	0.4
Ethanol(synthetic)	Ethylene hydration	Preheater	750	1.3	0.2
Acetone	Various	Hot oil furnace	NA	0.8	0.1
<b>High-temperature applications</b>					
Ethylene/propylene	Thermal cracking	Pyrolysis furnace	1900-2300	337.9	51.8
Ammonia	Natural gas reforming	Steam hydrocarbon reformer	1500-1600	150.5	23.1
Methanol	Hydrocarbon reforming	Steam hydration	1800-2000	25.7	4.0
Total known fired heater energy requirement				652.4	100

<sup>a</sup>Feedstock outlet temperature.  
NA = Data not available.



injection points and to increase the residence time. At full load operation, the optimal temperature window for both SNCR processes occur near the bottom of the convection section of typical pyrolysis furnace designs and in the middle of one of the reactor coils. The flue gas temperature drops rapidly at this point in the convection section. Therefore, access to a suitable temperature window and adequate residence time may be limited.<sup>23,27,30</sup>

Similar to SNCR, at full load operations, the optimal temperature window for SCR processes for olefins pyrolysis furnaces occurs near the bottom of the convection section and in the middle of one of the reactor coils. The stack temperatures (150° to 230°C [300° to 450°F]) are generally too low for SCR applications. In addition, plot space can be a problem for SCR retrofit because pyrolysis furnaces are typically built adjoining each other and are surrounded by feed, steam and fuel piping. To allow adequate space for maintenance procedures, the SCR unit would need to be located some distance away from the furnace it would serve. This would require the flue gas to be routed over this distance to reach the SCR.<sup>27,30</sup>

Coke fouling is an additional concern with using SCR on olefins pyrolysis furnaces. During cracking operations, the reactor coil can foul with coke deposits. These coke deposits must be removed periodically to prevent the coil from exceeding its metallurgical temperature limit and to avoid excessive pressure drop. Coke is removed by removing the hydrocarbon feed and purging the coil with steam and a small amount of air for a period of about 12 to 48 hours to promote oxidation of the coke deposits. The firing rate is lower than normal during this operation (approximately 30 percent of the normal firing rate), while the excess air value is higher (on the order of 150 percent versus 10 percent during normal operation). The flue gas temperature during the decoking operation is much lower than during normal operation and is not in the optimal temperature range for SCR operation.<sup>25</sup>

During the coke removal operation, the coke deposits are often injected into the heater. The SCR catalyst may be fouled if these deposits are injected into the firebox and are not completely combusted. Also, these deposits may be injected above the SCR unit and fall into the catalyst. Installing an SCR system would require an alternate method of disposing of the coke deposits.<sup>5</sup>

Reductions in NO<sub>x</sub> emissions have been achieved with LNB and ULNB's in olefins pyrolysis furnaces. The achievable NO<sub>x</sub> emission reductions using LNB's and ULNB's, however, are lower for pyrolysis furnace applications than for low- and medium-temperature heater applications. Steam cracker heaters strive to minimize coking rates in the radiant tubes and to maximize heater run lengths. Steam reformer heaters strive to avoid exceeding design heat densities that may either affect catalytic conversion, sinter catalyst rings, or result in exceeding the design allowable stress limits for the tubes.<sup>31</sup> Both pyrolysis heater types have process temperature and tube metal temperatures far exceeding most conventional heaters, and greater attention has been paid to pyrolysis burner design features than conventional burner designs.<sup>31</sup> To achieve a uniform heat distribution, pyrolysis furnace burner designs use extended flame patterns to achieve a maximum uniform heat distribution over the tube lengths. This extended flame spreads out the combustion zone, a design feature shared by LNB's and ULNB's. Because an extended combustion zone is already implemented in existing pyrolysis burner designs, potential NO<sub>x</sub> reduction percentages using LNB's and ULNB's in pyrolysis furnaces are lower than for low- and medium-temperature process heater applications.

Information for two new installations and several retrofit applications of LNB's to pyrolysis furnaces was available. The NO<sub>x</sub> emission rates for the new furnaces using LNB's were 0.103 and 0.108 lb/MMBtu for natural gas-fired operation.<sup>32</sup> For retrofit applications, one source reported that the lowest achievable controlled NO<sub>x</sub> emission rate is approximately 0.100 lb/MMBtu for natural gas-fired operation.<sup>33</sup> The available

data and information suggest that achievable controlled NO<sub>x</sub> emission levels for LNB's used with natural gas-fired pyrolysis furnaces range from 0.10 to 0.011 lb/MMBtu, which represents a 15 to 30 percent reduction from the uncontrolled range of 0.13 to 0.14 lb/MMBtu. For pyrolysis model heaters with LNB's, a 25 percent NO<sub>x</sub> reduction from uncontrolled levels is used in this study for natural gas-and refinery gas-fired applications.

For ULNB's installed in pyrolysis furnaces, one source reported that controlled NO<sub>x</sub> emission rates for retrofit installations are expected to range from 0.06 to 0.07 lb/MMBtu for their proprietary burner design firing natural gas fuel.<sup>33</sup> This controlled range represents a 44 to 59 percent reduction from the uncontrolled range of 0.13 to 0.14 lb/MMBtu. For pyrolysis model heaters with ULNB's, a 50 percent NO<sub>x</sub> reduction from uncontrolled levels is used in this study for natural gas-and refinery gas-fired applications. Applying Exxon's proprietary ULNB's (not available to non-Exxon installations) firing natural gas to a pyrolysis furnace (without preheat) indicates that emission levels of 50 ppmv at 3 percent O<sub>2</sub> are achievable.<sup>34</sup> Permits for five major ethylene plants in Texas and Louisiana limited NO<sub>x</sub> emissions in the range of approximately 67 to 190 ppmv.<sup>30</sup>

As discussed in Section 4.3.1, NO<sub>x</sub> emissions increase for refinery gas-fired operation due to the presence of hydrogen in the fuel. The expected increase in general for NO<sub>x</sub> emissions from refinery gas-fired operation over natural gas-fired levels is reported by one source to be 20 to 50 percent.<sup>32</sup> A second source estimated the increase in NO<sub>x</sub> emissions for hydrogen fuels to be limited 10 to 15 percent for LBN's and no appreciable increase in NO<sub>x</sub> emissions for hydrogen fuels for ULNB's.<sup>35</sup>

#### 5.5 ACHIEVABLE NO<sub>x</sub> EMISSION REDUCTIONS

This section summarizes the achievable NO<sub>x</sub> emission reductions for those NO<sub>x</sub> control techniques currently applied to process heaters in practice. The control techniques and combinations of control techniques currently in use are LNB's, ULNB's, SNCR, SCR, LNB's + FGR, LNB's + SNCR, and LNB's + SCR.

Natural to mechanical draft conversion and LEA operation are not considered stand alone NO<sub>x</sub> control techniques in this study because they are currently considered operational techniques. However, the difference in NO<sub>x</sub> emissions and the degree of retrofit or construction between control techniques operated with ND and control techniques operated with MD is substantial and is considered. The performance of staged-fuel and staged-air LNB overlap, and for the purposes of this study all types of LNB's are collectively referred to as LNB's. Low-NO<sub>x</sub> burners have replaced staged combustion using air lances as current burner technology. Therefore, staged combustion using air lances is not considered further.

To develop NO<sub>x</sub> emission reductions, each of the current control techniques was applied to each of the model heaters developed in Chapter 4. Tables 5-11 through 5-15 present achievable NO<sub>x</sub> reductions, controlled emissions, and emission reductions for 8,760 hours of operation per year (capacity factor of 1.0). The percent reductions used in Tables 5-11 through 5-15 represent reductions derived from available data or published information concerning process heaters. The controlled emissions were calculated by applying the percent reductions of each control technique to the uncontrolled emission factors of each model heater. The total effective reduction percentage is listed for each control technique. Thermal, fuel and postcombustion NO<sub>x</sub> percent reductions are listed for the control techniques applied to the oil-fired model heaters because it is necessary to apply the appropriate percent reductions to the uncontrolled emission factors. For example, the thermal NO<sub>x</sub> percent reductions should be applied to the thermal NO<sub>x</sub> uncontrolled emission factors and the fuel NO<sub>x</sub> percent reductions should be applied to the fuel NO<sub>x</sub> uncontrolled emission factors. The postcombustion NO<sub>x</sub> percent reductions refer to the reductions achieved by SNCR and SCR. Because these reductions occur downstream of the firebox, the postcombustion NO<sub>x</sub> percent reductions should be applied to the

TABLE 5-11. MODEL HEATERS: CONTROLLED EMISSIONS FOR ND, NATURAL GAS-FIRED, LOW- AND MEDIUM-TEMPERATURE HEATERS

Model heater capacity, MMBtu/yr	Uncontrolled NO <sub>x</sub> emission factor, lb/MMBtu <sup>a</sup>	NO <sub>x</sub> control technique	Total effective reduction, percent	Controlled NO <sub>x</sub> emissions, lb/MMBtu	Controlled NO <sub>x</sub> emissions, ppm @ 3% O <sub>2</sub>	NO <sub>x</sub> reduction, ton/yr <sup>c</sup>
17	0.098	(ND) LNB	50 <sup>b</sup>	0.049	41	3.65
		(ND) ULNB	75 <sup>c</sup>	0.025	21	5.47
		(ND) SNCR	60 <sup>d</sup>	0.039	33	4.38
		(ND) LNB + (ND) SNCR	80 <sup>b,d</sup>	0.020	16	5.84
36	0.098	(ND) LNB	50 <sup>b</sup>	0.049	41	7.73
		(ND) ULNB	75 <sup>c</sup>	0.025	21	11.6
		(ND) SNCR	60 <sup>d</sup>	0.039	33	9.27
		(ND) LNB + (ND) SNCR	80 <sup>b,d</sup>	0.020	16	12.36
77	0.098	(ND) LNB	50 <sup>b</sup>	0.049	41	16.5
		(ND) ULNB	75 <sup>c</sup>	0.025	21	24.8
		(ND) SNCR	60 <sup>d</sup>	0.039	33	19.8
		(ND) LNB + (ND) SNCR	80 <sup>b,d</sup>	0.020	16	26.4
121	0.098	(ND) LNB	50 <sup>b</sup>	0.049	41	26.0
		(ND) ULNB	75 <sup>c</sup>	0.025	21	39.0
		(ND) SNCR	60 <sup>d</sup>	0.039	33	31.2
		(ND) LNB + (ND) SNCR	80 <sup>b,d</sup>	0.020	16	41.55
186	0.098	(ND) LNB	50 <sup>b</sup>	0.049	41	39.9
		(ND) ULNB	75 <sup>c</sup>	0.025	21	60.0
		(ND) SNCR	60 <sup>d</sup>	0.039	33	47.9
		(ND) LNB + (ND) SNCR	80 <sup>b,d</sup>	0.020	16	63.87

<sup>a</sup>Uncontrolled emissions for natural gas-fired heaters are from thermal NO<sub>x</sub> formation.

<sup>b</sup>Reductions from LNB's represent a 50 percent reduction of thermal NO<sub>x</sub>. This reduction was adopted from Reference 5.

<sup>c</sup>Reductions from ULNB's represent a 75 percent reduction of thermal NO<sub>x</sub>. This reduction was adapted from Reference 14.

<sup>d</sup>Postcombustion NO<sub>x</sub> reduction by SNCR is 60 percent. This reduction was adopted from Reference 7.

<sup>e</sup>Reduction (tons/yr) equals the Capacity (MMBtu/hr) x NO<sub>x</sub> reduced (lb NO<sub>x</sub>/MMBtu) x 1 ton per 2,000 lb x 8,760 hr/yr; where NO<sub>x</sub> reduced is equal to uncontrolled emission factor minus the controlled emission factor.

TABLE 5-12. MODEL HEATERS: CONTROLLED EMISSIONS FOR MD, NATURAL GAS-FIRED, LOW- AND MEDIUM-TEMPERATURE HEATERS

Model heater capacity, MMBtu/hr	Uncontrolled NO <sub>x</sub> emission factor, lb/MMBtu <sup>a</sup>	NO <sub>x</sub> control technique	Total effective reduction, percent	Controlled NO <sub>x</sub> emissions, lb/MMBtu	Controlled NO <sub>x</sub> emissions, ppmv @ 3% O <sub>2</sub>	NO <sub>x</sub> reduction, tons/yr <sup>g</sup>
40	0.197	(MD) LNB	50 <sup>b</sup>	0.099	82	17.3
		(MD) ULNB	75 <sup>c</sup>	0.049	41	25.9
		(MD) SNCR	60 <sup>d</sup>	0.079	66	20.7
		(MD) SCR	75 <sup>e</sup>	0.049	41	25.9
		(MD) LNB + FGR	55 <sup>f</sup>	0.089	74	19.0
		(MD) LNB + SNCR	80 <sup>b,d</sup>	0.039	33	27.6
		(MD) LNB + SCR <sup>g</sup>	88 <sup>b,e</sup>	0.025	21	30.2
77	0.197	(MD) LNB	50 <sup>b</sup>	0.099	82	33.2
		(MD) ULNB	75 <sup>c</sup>	0.049	41	49.8
		(MD) SNCR	60 <sup>d</sup>	0.079	66	39.9
		(MD) SCR	75 <sup>e</sup>	0.049	41	49.8
		(MD) LNB + FGR	55 <sup>f</sup>	0.089	74	36.5
		(MD) LNB + SNCR	80 <sup>b,d</sup>	0.039	33	53.2
		(MD) LNB + SCR	88 <sup>b,e</sup>	0.025	21	58.1
114	0.197	(MD) LNB	50 <sup>b</sup>	0.099	82	49.2
		(MD) ULNB	75 <sup>c</sup>	0.049	41	73.8
		(MD) SNCR	60 <sup>d</sup>	0.079	66	59.0
		(MD) SCR	75 <sup>e</sup>	0.049	41	73.8
		(MD) LNB + FGR	55 <sup>f</sup>	0.089	74	54.1
		(MD) LNB + SNCR	80 <sup>b,d</sup>	0.039	33	78.7
		(MD) LNB + SCR	88 <sup>b,e</sup>	0.025	21	86.1
174	0.197	(MD) LNB	50 <sup>b</sup>	0.099	82	75.1
		(MD) ULNB	75 <sup>c</sup>	0.049	41	113
		(MD) SNCR	60 <sup>d</sup>	0.079	66	90.1
		(MD) SCR	75 <sup>e</sup>	0.049	41	113
		(MD) LNB + FGR	55 <sup>f</sup>	0.089	74	82.6
		(MD) LNB + SNCR	80 <sup>b,d</sup>	0.039	33	120
		(MD) LNB + SCR	88 <sup>b,e</sup>	0.025	21	131
263	0.197	(MD) LNB	50 <sup>b</sup>	0.099	82	113
		(MD) ULNB	75 <sup>c</sup>	0.049	41	170
		(MD) SNCR	60 <sup>d</sup>	0.079	66	136
		(MD) SCR	75 <sup>e</sup>	0.049	41	170
		(MD) LNB + FGR	55 <sup>f</sup>	0.089	74	125
		(MD) LNB + SNCR	80 <sup>b,d</sup>	0.039	33	182
		(MD) LNB + SCR	88 <sup>b,e</sup>	0.025	21	199

<sup>a</sup>Uncontrolled emissions for natural gas-fired heaters are from thermal NO<sub>x</sub> formation.

<sup>b</sup>Reductions from LNB's represent a 50 percent reduction of thermal NO<sub>x</sub>. This reduction was adopted from Reference 5.

<sup>c</sup>Reductions from ULNB's represent a 75 percent reduction of thermal NO<sub>x</sub>. This reduction was adapted from Reference 14.

<sup>d</sup>Postcombustion NO<sub>x</sub> reduction by SNCR is 60 percent. This reduction was adopted from Reference 7.

<sup>e</sup>Postcombustion NO<sub>x</sub> reduction by SCR is 75 percent. This reduction was adapted from Reference 14.

<sup>f</sup>Reductions from LNB + FGR represent a 55 percent reduction of thermal NO<sub>x</sub>. This reduction was adopted from Reference 7.

<sup>g</sup>Reduction (ton/yr) equals the Capacity (MMBtu/hr) \* NO<sub>x</sub> reduced (lb NO<sub>x</sub>/MMBtu) \* 1 ton per 2000 lb \* 8,760 hr/yr; where NO<sub>x</sub> reduced is equal to the uncontrolled emission factor minus the controlled emission factor.

TABLE 5-13. MODEL HEATERS: CONTROLLED EMISSIONS FOR ND OIL-FIRED HEATERS

Model heater capacity, MMBtu/hr	Fuel	Uncontrolled emission factor, lb/MMBtu		NO <sub>x</sub> control technique	NO <sub>x</sub> emission reduction, percent				Controlled NO <sub>x</sub> emission, lb/MMBtu	Controlled NO <sub>x</sub> emissions, ppmv	NO <sub>x</sub> reduction, tons/yr <sup>c</sup>
		Thermal NO <sub>x</sub> <sup>a</sup>	Fuel NO <sub>x</sub> <sup>b</sup>		Thermal NO <sub>x</sub>	Fuel NO <sub>x</sub>	Post-combustion	Total effective reduction			
69	Distillate oil	0.14	0.06	(ND) LNB <sup>d</sup>	50	15	N/A	40	0.121	101	23.9
				(ND) ULNB <sup>e</sup>	75	78	N/A	76	0.048	40.4	45.9
				(ND) SNCR <sup>f</sup>	N/A	N/A	60	60	0.080	67.0	36.3
				(ND) LNB + (ND) SNCR <sup>d,f</sup>	50	15	60	76	0.048	40.5	45.8
69	Residual oil	0.14	0.28	(ND) LNB <sup>d</sup>	50	15	N/A	27	0.308	258	33.8
				(ND) ULNB <sup>e</sup>	75	78	N/A	77	0.097	80.9	97.7
				(ND) SNCR <sup>f</sup>	N/A	N/A	60	60	0.168	140	76.2
				(ND) LNB + (ND) SNCR <sup>d,f</sup>	50	15	60	71	0.123	103	89.7

N/A = Not applicable.

<sup>a</sup>Uncontrolled emission factor for thermal NO<sub>x</sub> represents the NO<sub>x</sub> from thermal NO<sub>x</sub> formation.

<sup>b</sup>Uncontrolled emission factor for fuel NO<sub>x</sub> represents the NO<sub>x</sub> from fuel NO<sub>x</sub> formation.

<sup>c</sup>Reduction (ton/yr) equals the Capacity (MMBtu/hr) \* NO<sub>x</sub> reduced (lb NO<sub>x</sub>/MMBtu) \* 1 ton per 2000 lb \* 8,760 hr/yr, where NO<sub>x</sub> reduced is equal to the uncontrolled emission factor minus the controlled emission factor.

<sup>d</sup>These reductions were adopted from References 5 and 7.

<sup>e</sup>These reductions were adopted from References 7 and 14.

<sup>f</sup>These reductions were adopted from Reference 7.

TABLE 5 - 14. MODEL HEATERS: CONTROLLED EMISSIONS FOR MD OIL-FIRED HEATERS

Model heater capacity, MMBtu/hr	Fuel	Uncontrolled emission factor, lb/MMBtu		NO <sub>x</sub> control technique	NO <sub>x</sub> emission reduction, percent				Controlled NO <sub>x</sub> emissions, lb/MMBtu	Controlled NO <sub>x</sub> emissions, ppmv	NO <sub>x</sub> reduction, tons/yr <sup>c</sup>	
		Thermal NO <sub>x</sub> <sup>a</sup>	Fuel NO <sub>x</sub> <sup>b</sup>		Thermal NO <sub>x</sub>	Fuel NO <sub>x</sub>	Postcombustion	Total effective reduction				
135	Distillate oil	0.26	0.06	LNB <sup>d</sup>	50	25	N/A	N/A	45	0.175	139	85.7
				ULNB <sup>e</sup>	75	72	N/A	N/A	74	0.082	64.9	141
				SNCR <sup>f</sup>	N/A	N/A	60	60	102	0.128	114	
				SCR <sup>g</sup>	N/A	N/A	75	75	63.5	0.080	142	
				LNB + FGR <sup>h</sup>	55	15	N/A	N/A	48	0.168	89.9	
				LNB + SNCR <sup>d,f</sup>	50	25	60	78	55.6	0.070	148	
				LNB + SCR <sup>d,g</sup>	50	25	75	92	20.8	0.026	174	
				LNB <sup>d</sup>	50	25	N/A	37	270	0.340	118	
				ULNB <sup>e</sup>	75	72	N/A	73	114	0.143	235	
				SNCR <sup>f</sup>	N/A	N/A	60	60	171	0.216	192	
135	Residual	0.26	0.28	LNB + FGR <sup>h</sup>	55	15	N/A	N/A	75	0.135	107	240
				LNB + SNCR <sup>d,f</sup>	50	25	60	75	282	0.355	109	
				LNB + SCR <sup>d,g</sup>	50	25	75	91	108	0.136	239	
				LNB + SCR <sup>d,g</sup>	50	25	75	91	40.5	0.051	289	

N/A = Not applicable.

<sup>a</sup>Uncontrolled emission factor for thermal NO<sub>x</sub> represents the NO<sub>x</sub> from thermal NO<sub>x</sub> formation.

<sup>b</sup>Uncontrolled emission factor for fuel NO<sub>x</sub> represents the NO<sub>x</sub> from fuel NO<sub>x</sub> formation.

<sup>c</sup>Reduction (ton/yr) equals the Capacity (MMBtu/hr) \* NO<sub>x</sub> reduced (lb NO<sub>x</sub>/MMBtu) \* 1 ton per 2000 lb \* 8,760 hr/yr; where NO<sub>x</sub> reduced is equal to

the uncontrolled emission factor minus the controlled emission factor.

<sup>d</sup>These reductions were adopted from References 5 and 7.

<sup>e</sup>These reductions were adopted from References 7 and 14.

<sup>f</sup>These reductions were adopted from Reference 7.

<sup>g</sup>These reductions were adopted from Reference 14.

<sup>h</sup>These reductions were adopted from Reference 7.



TABLE 5-15. MODEL HEATERS: CONTROLLED EMISSIONS FOR ND OLEFINS PYROLYSIS HEATERS

Model heater capacity, MMBtu/hr	Fuel	Uncontrolled NO <sub>x</sub> emission factor, lb/MMBtu <sup>a</sup>	NO <sub>x</sub> control technique	Total effective reduction, percent	Controlled NO <sub>x</sub> emissions, lb/MMBtu	Controlled NO <sub>x</sub> emissions, ppmv	NO <sub>x</sub> reduction, ton/yr <sup>h</sup>
84	Natural gas	0.135	(ND) LNB	25 <sup>c</sup>	0.101	85	12.4
			(MD) LNB <sup>b</sup>	25 <sup>c</sup>	0.101	85	12.4
			(ND) ULNB	50 <sup>d</sup>	0.068	57	24.8
			(MD) ULNB <sup>b</sup>	50 <sup>d</sup>	0.068	57	24.8
			(ND) SNCR	60 <sup>e</sup>	0.054	45	29.8
			(MD) SNCR <sup>b</sup>	60 <sup>e</sup>	0.054	45	29.8
			SCR <sup>b</sup>	75 <sup>f</sup>	0.034	28	37.3
			LNB + FGR <sup>b</sup>	55 <sup>g</sup>	0.061	51	27.3
			(ND) LNB + SNCR <sup>b</sup>	70 <sup>c,e</sup>	0.041	34	34.8
			(MD) LNB + SNCR <sup>b</sup>	70 <sup>c,e</sup>	0.041	34	34.8
			LNB + SCR <sup>b</sup>	81 <sup>c,f</sup>	0.026	21	40.4
			(ND) LNB	25 <sup>c</sup>	0.123	343	14.9
			(MD) LNB <sup>b</sup>	25 <sup>c</sup>	0.123	343	14.9
			(ND) ULNB	50 <sup>d</sup>	0.081	229	29.8
(MD) ULNB <sup>b</sup>	50 <sup>d</sup>	0.081	229	29.8			
(ND) SNCR	60 <sup>e</sup>	0.065	183	35.8			
(MD) SNCR <sup>b</sup>	60 <sup>e</sup>	0.065	183	35.8			
(SCR) <sup>b</sup>	75 <sup>f</sup>	0.041	114	44.7			
LNB + FGR <sup>b</sup>	55 <sup>g</sup>	0.073	206	32.8			
(ND) LNB + SNCR <sup>b</sup>	70 <sup>c,e</sup>	0.049	137	41.7			
(MD) LNB + SNCR <sup>b</sup>	70 <sup>c,e</sup>	0.049	137	41.7			
LNB + SCR <sup>b</sup>	81 <sup>c,f</sup>	0.031	86	48.4			
84	High-hydrogen fuel gas	0.162					

<sup>a</sup>Uncontrolled emissions for natural gas-fired heaters are from thermal NO<sub>x</sub> formation.

<sup>b</sup>Emission reductions are based on ND emission factors using a 100 percent capacity utilization.

<sup>c</sup>Reductions from LNB's represent a 25 percent reduction of thermal NO<sub>x</sub>.

<sup>d</sup>Reductions from ULNB's represent a 50 percent reduction of thermal NO<sub>x</sub>.

<sup>e</sup>Postcombustion NO<sub>x</sub> reduction by SNCR is 60 percent. This reduction was adapted from Reference 7.

<sup>f</sup>Postcombustion NO<sub>x</sub> reduction by SCR is 75 percent. This reduction was adapted from Reference 14.

<sup>g</sup>Reductions from LNB + FGR represent a 55 percent reduction of thermal NO<sub>x</sub>. This reduction was adapted from Reference 7.

<sup>h</sup>Reduction (ton/yr) equals the Capacity (MMBtu/hr) \* NO<sub>x</sub> reduced (lb NO<sub>x</sub>/MMBtu) \* 1 ton per 2000 lb \* 8,760 hr/yr, where NO<sub>x</sub> reduced is equal to the uncontrolled emission factor

minus the controlled emission factor.

amount of NO<sub>x</sub> remaining after reductions of combustion controls have been applied.

Table 5-11 presents the performance of the available control techniques applied to the ND, natural gas-fired, low- and medium temperature model heaters. The controlled NO<sub>x</sub> emissions range from 0.021 lb/MMBtu for LNB plus SCR to 0.072 lb/MMBtu for LNB.

Table 5-12 presents the performance of the available control techniques applied to the MD, natural gas-fired, low- and medium-temperature model heaters. The controlled NO<sub>x</sub> emissions range from 0.021 lb/MMBtu for LNB's plus SCR to 0.089 lb/MMBtu for LNB's plus FGR.

The percent reductions in Table 5-13 for the ND oil-fired model heater are listed for thermal, fuel and postcombustion NO<sub>x</sub> reductions. The controlled NO<sub>x</sub> emissions for the distillate oil-fired model heater range from 0.048 lb/MMBtu for ULNB's to 0.121 lb/MMBtu for LNB's. The controlled NO<sub>x</sub> emissions for the residual oil-fired model heater range from 0.097 lb/MMBtu for ULNB to 0.308 lb/MMBtu for LNB's.

The percent reductions in Table 5-14 for the MD oil-fired model heater are listed for thermal, fuel, and postcombustion NO<sub>x</sub> reductions. The controlled NO<sub>x</sub> emissions for the distillate oil-fired model heater range from 0.026 lb/MMBtu for LNB's plus SCR to 0.175 lb/MMBtu for LNB's. The controlled NO<sub>x</sub> emissions for the residual oil-fired model heater range from 0.051 lb/MMBtu for LNB's plus SCR to 0.319 lb/MMBtu for LNB's plus FGR.

Table 5-15 presents the performance of the available control techniques applied to the olefins pyrolysis model heaters. The controlled NO<sub>x</sub> emissions for the natural gas-fired model heater range from 0.026 lb/MMBtu for LNB's plus SCR to 0.101 lb/MMBtu for LNB's. The controlled NO<sub>x</sub> emissions for the high-hydrogen fuel-fired model heater range from 0.031 lb/MMBtu for LNB's plus SCR to 0.123 lb/MMBtu for LNB's.

Again, it is important to recognize that the percent emission reductions listed in Tables 5-11 through 5-15 represent the available data collected and in some cases corresponds to a specified emission limit rather than the maximum achievable

percent emission reduction. For example, the use of LNB plus SCR is likely capable of an overall NO<sub>x</sub> emissions reduction of over 90 percent; however, available data show an average reduction of 75 percent for SCR, which represents the level of control needed to meet an emission limit.

#### 5.6 REFERENCES FOR CHAPTER 5

1. Shareef, A., C. Anderson, and L. Keller (Radian Corporation). Fired Heaters: Nitrogen Oxides Emissions and Controls. June 29, 1988.
2. Project Summary. Evaluation of Natural- and Forced-Draft Staging Air Systems for Nitric Oxide Reduction in Refinery Process Heaters. EPA-600/S7-84-080. September 1984.
3. Project Summary. Guidelines for the Reduction of Emissions & Efficiency Improvements for Refinery Process Heaters. EPA-600/S8-83-017. June 1983.
4. Project Summary. Thirty-Day Field Test of a Refinery Process Heater Equipped with Low-NO<sub>x</sub> Burners. EPA-600/S7-83-010. April 1983.
5. Letter and attachments from Eichamer, P., Exxon Chemical Company, to Neuffer, W., EPA/ISB. September 2, 1992. Comments on Draft Alternative Control Techniques Document--Control of NO<sub>x</sub> Emissions from Process Heaters.
6. Letter and attachments from Laffly, G., American Petroleum Institute, to Neuffer, W., EPA/ISB. August 10, 1992. Comments on Draft Alternative Control Techniques Document--Control of NO<sub>x</sub> Emissions from Process Heaters.
7. A Study to Assess the Available Technology and Associated Costs of Reducing NO<sub>x</sub> Emissions From the Canadian Petroleum Refining Industry. Canadian Petroleum Products Institute. CPPI Report No. 91-1. November 28, 1990.
8. Campbell, L., D. Stone, and G. Shareef (Radian Corporation). EPA-600/2-91-029. July 1991. Sourcebook: NO<sub>x</sub> Control Technology Data.
9. Letter from Martin, R., Callidus Technologies Incorporated, to Neuffer, W., EPA/ISB. January 26, 1993. Comments on Draft Alternative Control Techniques Document--Control of NO<sub>x</sub> Emissions from Process Heaters.
10. Waibel, R. (John Zink Company). Low Emission Burners for Steam Generation. IGT Conference and Exhibition. April 13 and 14, 1988.

11. Letter from Craig, R. Unocal Science and Technology Division, to Lee, L., California Air Resources Board. July 24, 1991. Information concerning NO<sub>x</sub> reduction in a cogeneration facility.
12. Waibel, R. (John Zink Company). Advanced Burner Technology for Stringent NO<sub>x</sub> Regulations. Presented at American Petroleum Institute Midyear Refining Meeting. May 8, 1990.
13. Letter and attachments from Quiel, J., North American Manufacturing Company, to Neuffer, W., EPA/ISB. May 1991. Low NO<sub>x</sub> burner and FGR information from manufacturer.
14. Letter and attachments from Britt, J., Mobil Oil Corporation, to Jordan, B., EPA/ESD. April 29, 1992. Process heater NO<sub>x</sub> emission control retrofit experience at Mobil's Torrance, CA, petroleum refinery.
15. Letter and attachments from Grever, A., Selas, to Neuffer, W., EPA/ISB. December 29, 1992. Comments on Draft Alternative Control Techniques Document--Control of NO<sub>x</sub> Emissions from Process Heaters.
16. Letter and attachments from Davis, L., Exxon, Baton Rouge to Harris, R., MRI. February 7, 1992. Refinery Inventory of Process Heaters.
17. Letter and attachments from Johnson, W., John Zink Company, to Hamilton, R., Texas Air Control Board. December 5, 1990. Meeting SCAQMD Rules 1109 and 1146 with Low-NO<sub>x</sub> Burners. Presented by Waibel, R., PhD.
18. Minden, A., and P. Gilmore. NO<sub>x</sub> Control in Gas-Fired Refinery Process Heaters Using Pyrocore Radiant Burners. Paper presented at 1988 Fall Meeting of Western States Section/The Combustion Institute. October 17-18, 1988.
19. Minden, A., D. Perkins, J. Kennedy (Alzeta Corp.). Premixed Radiant Burners: Improved Process Performance with Ultra-Low NO<sub>x</sub> Emissions. Combustion Institute. 1990.
20. Letter and attachments from Moreno, F., Alzeta Corporation, to Sanderford, E., MRI. July 1992. Cost comparison between ND and MD conventional burners versus Alzeta burners.
21. Letter and attachments from Moreno, F., Alzeta Corporation, to Sanderford, E., MRI. June 3, 1992. Control of NO<sub>x</sub> using Alzeta burners.
22. McInnes, R., and M.B. Van Wormer. Cleaning Up NO<sub>x</sub> Emissions. Chemical Engineering. Vol. 130-135. September 1990.

23. Letter and attachments from Pickens, R., Nalco Fuel Tech, to Neuffer, W., EPA/ISB. August 7, 1992. Comments on Draft Alternative Control Techniques Document--Control of NO<sub>x</sub> Emissions from Process Heaters.
24. Letter and attachments from Haas, G., Exxon Research and Engineering Company, to Lazzo, D., MRI. January 14, 1991. Thermal DeNO<sub>x</sub> installation list.
25. Teixeira, D. Widening the Urea Temperature Window. Pacific Gas and Electric Company. Paper presented at 1991 EPA\EPRI Joint Symposium.
26. Letter and attachments from Pickens, R., Nalco Fuel Technologies, to Snyder, R., MRI. February 5, 1992. Data for NO<sub>x</sub>OUT<sup>®</sup> installations.
27. Letter and attachments from Strickland, G., Chemical Manufacturers Association, to Neuffer, W., EPA/ISB. September 9, 1992. Comments on Draft Alternative Control Techniques Document--Control of NO<sub>x</sub> Emissions from Process Heaters.
28. Letter and attachments from Wax, M., Institute of Clean Air Companies, to Neuffer, W., EPA/ISB. August 27, 1992. Comments on Draft Alternative Control Techniques Document--Control of NO<sub>x</sub> Emissions from Process Heaters.
29. Letter and attachments from Franklin, H., Foster Wheeler Energy Corporation, to Neuffer, W., EPA/ISB. April 27, 1992. Process heater SCR experience.
30. Gomma H., L. Hackemesser, and D. Cindric. NO<sub>x</sub>/CO Emissions and Control in Ethylene Plants. Environmental Progress. 10(4). November 1991.
31. Letter and Eichamer, P. D., and N. L. Morrow, Exxon Chemical Company, to Neuffer, W. J., EPA/ISB. July 7, 1993. NO<sub>x</sub> reductions in pyrolysis furnaces.
32. Letter from Moran, E. J., Chemical Manufacturers Association, to Neuffer, W. J., EPA/ISB. July 22, 1993. NO<sub>x</sub> reductions in pyrolysis furnaces using low-NO<sub>x</sub> burners.
33. Letter from Eichamer, P. D., and N. L. Morrow, Exxon Chemical Company, to Neuffer, W. J., EPA/ISB. June 7, 1993. NO<sub>x</sub> reductions in pyrolysis furnaces.

34. Letter and attachments from Morrow, N., Exxon Chemical Group, to Harris, R., MRI. February 24, 1992. Low-NO<sub>x</sub> burner experience at basic chemicals plant.
35. Letter from Eichamer, P. D., and N. L. Morrow, Exxon Chemical Company, to Neuffer, W. J., EPA/ISB. July 19, 1993. Effect of hydrogen fuel content on NO<sub>x</sub> reductions in pyrolysis furnaces.

## 6.0 CONTROL COSTS

This chapter presents capital and annual costs and cost effectiveness for the NO<sub>x</sub> emission control techniques described in Chapter 5. These control techniques are applied to the model heaters presented in Chapters 4 and 5. The NO<sub>x</sub> control techniques are low-NO<sub>x</sub> burners (LNB's), ultra low-NO<sub>x</sub> burners (ULNB's), selective noncatalytic reduction (SNCR), selective catalytic reduction (SCR), LNB's combined with flue gas recirculation (FGR), LNB's combined with SNCR, and LNB's combined with SCR. These control techniques were selected because they are currently used to control NO<sub>x</sub> emissions.

Cost estimates are highly variable, and accurate estimates can only be made on a case-by-case basis. The costs presented in this study give approximate costs of implementing the available control techniques. Costing methodologies from References 1 and 2 are used to estimate the costs. These methodologies estimate the costs of retrofitting control techniques on process heaters.<sup>1,2</sup> It is expected that the cost of incorporating a control technique in the design of a new process heater is less than retrofitting a similar heater with the same control technique.

Capital and annual cost methodologies for NO<sub>x</sub> control techniques applied to the model heaters are presented in Section 6.1. The total annual costs (TAC) for the NO<sub>x</sub> control techniques applied to the model heaters are presented in Section 6.2. The cost effectiveness of the NO<sub>x</sub> control techniques applied to the model heaters is presented in Section 6.3. Radiant burner costs are discussed in Section 6.4; radiant burners are not included in the model heater cost

analysis due to limited costing information. Section 6.5 lists the references used in this chapter.

## 6.1 CAPITAL AND ANNUAL COSTS METHODOLOGIES

The methodology used to develop capital costs is essentially the same for each NO<sub>x</sub> control technique. Because available cost data for this study were limited, capital cost methodologies from References 1 and 2 were used to develop capital costs for each individual control technique. The capital costs were updated to 1991 U.S. dollars using the Chemical Engineering plant cost index.<sup>3</sup> Capital costs for combinations of controls are the sum of the capital costs of the individual control techniques.

The TAC for the NO<sub>x</sub> control techniques comprises the annual operating costs of chemicals, electricity, fuel, and maintenance. The costs, in 1991 dollars, for electricity, fuel, chemical reactants, and maintenance are shown in Table 6-1. Capital and annual costs for LNB's, ULNB's, SNCR, SCR, FGR, LNB's plus SNCR, and LNB's plus SCR are presented in Sections 6.1.1 through 6.1.7, respectively. Each of these sections presents the methodology used to develop capital and annual costs. Natural draft (ND)-to-mechanical draft (MD) conversion is not considered a stand-alone control technique but is required to implement some control techniques. The capital and annual costs of ND-to-MD conversion are considerable and are presented in Section 6.1.8.

### 6.1.1 Costs of LNB's

6.1.1.1 Capital Costs of LNB's. The LNB capital cost methodology from Reference 1 was used to calculate the capital cost of applying LNB's to process heaters. The primary parameters affecting the capital cost include the following:

1. Heater capacity;
2. Number of burners;
3. Burner heat release rate; and
4. Natural or forced draft combustion air delivery system.<sup>1</sup>

The capital cost methodology from Reference 1 for ND heaters is:

$$\text{TIC} = 30,000 + \text{HQ} [5,230 - (622 \times \text{BQ}) + (26.1 \times \text{BQ}^2)]$$



TABLE 6-1. UTILITY, CHEMICAL, AND MAINTENANCE COSTS

Electricity <sup>a</sup>	\$0.06/kWh
Natural gas <sup>b</sup>	\$2.00/MMBtu
Distillate fuel oil <sup>c</sup>	\$5.54/MMBtu
Residual fuel oil <sup>c</sup>	\$3.00/MMBtu
Ammonia <sup>d</sup>	\$0.125/lb
Maintenance <sup>e</sup>	2.75% of capital cost

<sup>a</sup>Reference 4, Table 5-10.

<sup>b</sup>Reference 5.

<sup>c</sup>Reference 6.

<sup>d</sup>Reference 2.

<sup>e</sup>Reference 1.

where:

TIC = total capital installed cost;

HQ = heater capacity (GJ/hr); and

BQ = burner heat release rate (GJ/hr)

and

$$BQ = HQ/NB \times (1.158 + 8/HQ)$$

where:

NB = number of burners.

The LNB capital cost for MD heaters is calculated to be 50 percent higher than the capital cost for ND heaters. This additional cost is added to account for the following:

1. Increased LNB cost;
2. Additional excess air control equipment; and
3. Combustion air plenum modification.<sup>1</sup>

The capital cost methodology for MD LNB's is:

$$TIC = 1.5 \times \{30,000 + HQ \times [5,230 - (622 \times BQ) + (26.1 \times BQ^2)]\}.$$

The cost methodologies give costs in Canadian average 1990 dollars. For this analysis, the capital costs have been escalated to U.S. average 1991 dollars using the Chemical Engineering plant cost index and an exchange rate of 1 U.S. dollar to 1.15 Canadian dollars.<sup>3</sup>

The cost of the burners, although substantial, represents a fraction of the actual installed costs. Large cost variations for LNB retrofit installations can occur when floor rebuilding is required and space limitations below the heater exist. Typical LNB's do not fit standard burner mounts and may require complete floor rebuilds and refractory replacement. Not all heaters can be retrofitted with current LNB designs. The primary variable influencing the feasibility of an LNB retrofit is the space requirement below the heater necessary to install the combustion air plenums.<sup>8,9</sup>

6.1.1.2 Operating Costs of LNB's. Maintenance costs of LNB's are calculated as 2.75 percent of the LNB's capital costs.<sup>1,2</sup> Installation of LNB's can improve heater efficiency, although this effect (if any) will be strongly heater-dependent.

The potential increase in heater efficiency may lower fuel costs. Operational costs may be marginally increased due to the decrease in flame stability and the potential for flame-out.<sup>1,8</sup> These operational impacts will tend to offset one another in the cost analysis associated with LNB installation and minimize the effect of the current analysis.<sup>1</sup> These costs are site-specific and are not included in the cost analysis.

#### 6.1.2 Cost of ULNB's

6.1.2.1 Capital Costs of ULNB's. The capital costs of ULNB's are affected by the same parameters as LNB's. The primary parameters that affect the capital costs include:

1. Heater capacity;
2. Number of burners;
3. Burner heat release rate; and
4. Natural or mechanical draft combustion air delivery system.

The capital cost methodology for ND ULNB's is:

$$\text{TIC} = 35,000 + \{ \text{HQ} \times [5,230 - (622 \times \text{BQ}) + (26.1 \times \text{BQ}^2)] \}.$$

In the case of MD heaters, an additional 50 percent is added to the capital cost to account for the following:

1. Additional excess air control equipment; and
2. Increased combustion air plenum construction.

The capital cost methodology for MD ULNB's is:

$$\text{TIC} = 1.5 \times \{ 35,000 + \text{HQ} \times [5,230 - (622 \times \text{BQ}) + (26.1 \times \text{BQ}^2)] \}.$$

The cost methodologies give costs in Canadian average 1990 dollars. For this analysis, the capital costs have been escalated to U.S. average 1991 dollars using the Chemical Engineering plant index and an exchange rate of 1 U.S. dollar to 1.15 Canadian dollars.<sup>3</sup>

Similar to LNB's, large cost variations for ULNB's retrofit can exist. The cost variations and variables influencing the use of LNB's described in Section 6.1.1.1 also apply to ULNB's.

6.1.2.2 Operating Costs of ULNB's. Maintenance costs of ULNB's are calculated as 2.75 percent of the ULNB's capital

costs.<sup>1,2</sup> Operating costs for LNB's described in Section 6.1.1.2 also apply to ULNB's.

### 6.1.3 Costs of SNCR

6.1.3.1 Capital Costs of SNCR. The SNCR capital cost methodology from Reference 1 has been used to calculate the capital cost of installing SNCR in process heaters. The cost methodology in Reference 1 uses data from Exxon's Thermal DeNO<sub>x</sub><sup>®</sup> (TDN<sup>®</sup>) process because Nalco Fuel Tech's process to date has been installed on only a limited number of refinery heaters. The major capital costs for SNCR systems are for the ductwork, reactant storage tank and injection system, insulation, control instrumentation, engineering, and installation. The capital cost methodology for SNCR from Reference 1 is:

$$\text{TIC} = 31,850 (\text{HQ})^{0.6}$$

where:

HQ is the heater capacity, in gigajoules per hour (GJ/hr).

The cost methodology gives costs in Canadian average 1990 dollars. For this analysis, capital costs have been escalated to U.S. average 1991 dollars using the Chemical Engineering plant index and an exchange rate of 1 U.S. Dollar to 1.15 Canadian dollars.<sup>3</sup>

6.1.3.2 Operating Costs of SNCR. The SNCR annual operating cost models from References 1 and 2 are used to calculate the annual operating costs of SNCR operation. Maintenance costs of SNCR are calculated as 2.75 percent of the SNCR capital costs.<sup>1,2</sup> The operating costs include the cost of ammonia reactant, additional electricity, and additional fuel. The Reference 2 cost model was used to calculate the operating costs for NH<sub>3</sub> and electricity. The fuel penalty results from a loss of heater thermal efficiency due to dilution of the hot flue gas with steam or cold distribution air, which lowers the convection section heat recovery.<sup>1</sup> The loss in efficiency is estimated to require a 0.3 percent increase in fuel firing. The cost of the fuel penalty is calculated as a 0.3 percent increase in firing rate.<sup>9</sup>

The cost methodologies for the annual operating costs of SNCR are:

$$\begin{aligned} \text{NH}_3 \text{ cost} &= (Q) \times (\text{lb NO}_x/\text{MMBtu}) \times (1 \text{ mole} \\ &\quad \text{NO}_2/46 \text{ lb NO}_2) \times (17 \text{ lb NH}_3/1 \text{ mole} \\ &\quad \text{NH}_3) \times (\text{mole NH}_3/\text{mole NO}_x) \times \\ &\quad (\$0.125/\text{lb NH}_3) \times (8,760 \text{ hr/yr}) \times \text{CF}, \\ \text{Electricity cost} &= (0.3 \text{ kWh/ton NH}_3) \times (\text{ton NH}_3/\text{yr}) \times \\ &\quad (\$0.06/\text{kWh}) \times \text{CF} \\ \text{Fuel penalty cost} &= (0.03) \times (Q) \times (8,760 \text{ hr/yr}) \times (\text{fuel} \\ &\quad \text{cost } \$/\text{MMBtu}) \times \text{CF}, \end{aligned}$$

where:

Q = heater capacity, MMBtu/hr, and

CF = capacity factor expressed in decimal form.<sup>1,2,10</sup>

#### 6.1.4 Costs of SCR

6.1.4.1 Capital Costs of SCR. The SCR capital cost methodology from Reference 2 was used to calculate the capital cost of installing SCR in process heaters. The major capital costs for SCR systems are for the reactor section (including catalyst), ductwork, ammonia storage tank and injection system, foundation, insulation, control instrumentation, engineering, and installation.<sup>2,11</sup> Selective catalytic reductions systems require mechanical draft operation due to the pressure drop across the catalyst. The costs for SCR applied to the ND model heaters includes the costs of converting to MD operation in addition to the SCR costs.<sup>2</sup>

The capital cost model from Reference 2 is:

$$\text{TIC} = 1,373,000 \times (Q/48.5)^{0.6} + 49,000 \times (Q/485),$$

where:

Q = heater capacity, MMBtu/hr.<sup>2</sup>

The cost methodology gives costs in U.S. average 1986 dollars. For this analysis, capital costs have been escalated to U.S. average 1991 dollars using the Chemical Engineering plant index.<sup>3</sup>

6.1.4.2 Operating Costs of SCR. The SCR annual operating costs were calculated using the methodologies from Reference 2. The operating costs include the cost of the ammonia reactant,

catalyst replacement, additional electricity and additional fuel. The Reference 2 cost methodology was used to calculate the NH<sub>3</sub>, catalyst replacement, and electricity costs. A 1 to 2 percent loss of heater thermal efficiency can be expected due to dilution of the hot flue gas with cold distribution air, which lowers convection section heat recovery. This loss of efficiency is represented by a fuel penalty; the cost of the fuel penalty is estimated to require a 1.5 percent increase in fuel consumption.<sup>1</sup>

The cost methodology for annual operating costs of SCR:

$$\begin{aligned} \text{NH}_3 \text{ cost} = & (Q) \times (\text{lb NO}_x/\text{MMBtu}) \times (1 \text{ mole} \\ & \text{NO}_2/46 \text{ lb NO}_2) \times (17 \text{ lb} \\ & \text{NH}_3/1 \text{ mole NH}_3) \times (\text{mole NH}_3/\text{mole} \\ & \text{NO}_x) \times (\$0.125/\text{lb NH}_3) \\ & \times (8,760 \text{ hr/yr}) \times \text{CF}; \end{aligned}$$

$$\text{Catalyst replacement cost} = 49,000 \times (Q/48.5)/5 \text{ yr}$$

$$\begin{aligned} \text{Electricity cost} = & (0.3 \text{ kWh/ton NH}_3) \times (\text{ton NH}_3) \times \\ & (\$0.06/\text{kWh}) \times \text{CF}, \text{ and} \end{aligned}$$

$$\begin{aligned} \text{Fuel penalty cost} = & (0.015) \times (Q) \times (8,760 \text{ hr/yr}) \times \\ & (\text{fuel cost } \$/\text{MMBtu}) \times \text{CF}, \end{aligned}$$

where:

Q = heater capacity, MMBtu/hr, and

CF = capacity factor expressed in decimal form.

Maintenance costs for SCR are calculated as 2.75 percent of the SCR capital cost.<sup>1,2</sup>

#### 6.1.5 Costs of FGR

6.1.5.1 Capital Costs of FGR. The FGR capital cost methodology from Reference 1 is used to calculate the capital cost of installing an FGR system in process heaters. The capital cost model for FGR from Reference 1 is:

$$\text{TIC} = 12,800 (\text{HQ})^{0.6}$$

where:

HQ = heater capacity, GJ/hr.<sup>1</sup>

The cost methodology gives cost in Canadian average 1990 dollars. For this analysis, the capital costs have been escalated to U.S. average 1991 dollars using the Chemical

Engineering plant index and an exchange rate of 1 U.S. dollar to 1.15 Canadian dollars.<sup>3</sup>

As discussed in Chapter 5, FGR is not considered to be a stand-alone NO<sub>x</sub> control technique but is typically combined with LNB's. Flue gas recirculation requires an MD combustion air supply. For ND heaters, implementing FGR as a NO<sub>x</sub> control technique incurs the following capital costs: ND-to-MD conversion, MD LNB's, and the FGR system.

The cost methodology is based on boiler data because process heater applications of FGR are limited. An additional consideration for FGR is the high-temperature flue gas associated with process heaters. Boilers use economizers to recover a large amount of thermal energy from the flue gas in boilers. Process heaters do not have economizers and therefore have higher flue gas temperatures than do boilers. Flue gas recirculation fans capable of handling the high-temperature flue gas from process heaters may increase the cost of implementing FGR over the costs presented in this chapter.

6.1.5.2 Operating Costs of FGR. The FGR annual operating cost model from Reference 2 has been used to calculate the annual operating costs of FGR operation. The primary cost associated with FGR operation is the additional electrical energy required to operate the FGR fan. The annual cost model for FGR from Reference 2 is presented below:

$$\text{Electric power cost} = (\text{motor hp}) \times (0.75 \text{ kW/hp}) \times \\ (8,760 \text{ hr/yr}) \times (\$0.06/\text{kWh}) \times \text{CF}$$

where:

$$\begin{aligned} \text{motor hp} &= \text{FGR fan motor horsepower, } (1/5) \times (Q); \\ Q &= \text{process heater capacity in MMBtu/hr, and} \\ \text{CF} &= \text{heater capacity factor.} \end{aligned}$$

Maintenance costs for FGR are calculated as 2.75 percent of the capital cost.<sup>1,2</sup>

#### 6.1.6 Costs of LNB's Plus SNCR

6.1.6.1 Capital Costs of LNB's Plus SNCR. The capital cost of LNB's plus SNCR is the sum of the capital cost of LNB's, presented in Section 6.1.1.1, and the capital cost of SNCR,

presented in Section 6.1.3.1. Selective noncatalytic reduction systems may be applied to ND or MD systems without modifications to the draft system. Therefore, either ND LNB's or MD LNB's may be combined with SNCR.

6.1.6.2 Operating Costs of LNB's Plus SNCR. The operating and maintenance costs of LNB's plus SNCR are the sum of the operating and maintenance costs for LNB's, presented in Section 6.1.1.2, and the operating and maintenance costs for SNCR, presented in Section 6.1.3.2.

#### 6.1.7 Costs of LNB's Plus SCR

6.1.7.1 Capital Costs of LNB's Plus SCR. The capital cost of LNB's plus SCR is the sum of the capital cost of LNB's, presented in Section 6.1.1.1, and the capital cost of SCR, presented in Section 6.1.4.1. Selective catalytic reduction systems require MD operation. Therefore, ND heaters must be converted to MD operation for SCR.

6.1.7.2 Operating Costs of LNB's Plus SCR. The operating and maintenance costs of LNB's plus SCR are the sum of the operating and maintenance costs for LNB's, presented in Section 6.1.1.2, and the operating and maintenance costs for SCR, presented in Section 6.1.4.2.

#### 6.1.8 Costs of ND-to-MD Conversion

6.1.8.1 Capital Costs of ND-to-MD Conversion. The ND-to-MD conversion capital cost methodology from Reference 1 is applied to calculate the capital cost of converting process heaters from ND to MD. The capital cost model for ND-to-MD conversion from Reference 1 is:

$$\text{TIC} = 21,350 (\text{HQ})^{0.6}$$

where:

$$\text{HQ} = \text{heater capacity, GJ/hr.}^1$$

The cost methodology gives costs in Canadian average 1991 dollars. For this analysis, capital costs have been escalated to U.S. 1991 dollars using the Chemical Engineering plant indexes and an exchange rate of 1 U.S. dollar to 1.15 Canadian dollars.<sup>3</sup>

As discussed in Chapter 5, ND-to-MD conversion is generally not performed as a stand-alone NO<sub>x</sub> control technique. The



capital costs of converting ND heaters to MD heaters is added to the costs of control techniques where conversion from ND to MD is required. The control techniques that require ND heater conversion to MD are MD LNB's, MD ULNB's, MD SNCR, SCR, MD LNB's plus FGR, MD LNB's plus SNCR, and MD LNB's plus SCR.

#### 6.1.8.2 Operating Costs of ND-to-MD Conversion.

Maintenance costs for MD heaters are greater than for ND heaters. Maintenance costs associated with ND-to-MD conversion are calculated as 2.75 percent of the ND-to-MD capital cost.<sup>1,2</sup> Conversion from ND-to-MD increases heater thermal efficiency. Potential fuel reductions of 1.5 percent can lead to a yearly savings equivalent to about 4 to 8 percent of the capital cost to retrofit a medium sized heater ND heater to MD LNB's.<sup>1</sup> This efficiency gain is site-specific, however, and has not been included in the cost analysis.

### 6.2 TOTAL ANNUAL COST FOR MODEL HEATERS

The TAC for applying NO<sub>x</sub> control techniques to model heaters is presented in this section. The TAC is the sum of the capital recovery cost and the annual cost. The capital recovery cost is estimated for each NO<sub>x</sub> control technique by multiplying the capital costs by the capital recovery factor (CRF). The CRF is estimated by the following method:

$$CRF = [i \times (1+i)^n] / [(1+i)^n - 1]$$

where:

i = pretax marginal rate of return (10 percent), and

n = equipment economic life (15 years).<sup>4</sup>

The capital and annual cost methodologies are presented in Section 6.1.

Sections 6.2.1 through 6.1.5 present the capital costs, capital recovery, annual costs, and TAC's for NO<sub>x</sub> control techniques applied to the model heaters. Total annual costs are calculated for capacity factors of 0.1, 0.5, and 0.9. However, only TAC for the capacity factor of 0.9 are discussed in these sections. Sections 6.2.1 and 6.2.2 present these costs for the ND low- and medium-temperature and MD low- and medium-temperature gas-fired model heaters, respectively. Sections 6.2.3 and 6.2.4

present these costs for the ND low- and medium-temperature and MD low- and medium-temperature oil-fired model heaters, respectively. Section 6.2.5 presents the capital costs, capital recovery, annual costs, and TAC's for the olefins pyrolysis model heaters. The ND-to-MD conversion costs are presented in Section 6.2.6.

#### 6.2.1 Control Costs for the ND Gas-Fired, Low- and Medium-Temperature Model Heaters

Table 6-2 presents the capital costs, annual costs, and TAC's for the ND gas-fired, low-and medium-temperature model heaters. The capital costs of the control techniques range from \$58,200 for ND LNB's used on the 17 MMBtu/hr heater to \$4,650,000 for MD LNB's plus SCR used on the 186 MMBtu/hr heater. The TAC's range from \$9,250/yr for ND LNB's on the 17 MMBtu/hr heater to \$835,000/yr for MD LNB's plus SCR on the 186 MMBtu/hr heater.

#### 6.2.2 Control Costs for MD Gas-Fired, Low- and Medium-Temperature Model Heaters

Table 6-3 presents the capital costs, annual costs, and TAC's for the MD gas-fired, low- and medium-temperature model heaters. The capital costs of the control techniques range from \$130,000 for LNB's used on the 40 MMBtu/hr heater to \$5,360,000 for LNB's plus SCR used on the 236 MMBtu/hr heater. The TAC's range from \$20,700/yr for LNB's used on the 40 MMBtu/hr heater to \$988,000/yr for LNB's plus SCR used on the 263 MMBtu/hr heater.

#### 6.2.3 Control Costs for ND Oil-Fired, Low- and Medium-Temperature Model Heaters

Table 6-4 presents the capital costs, annual costs, and TAC's for the ND oil-fired, low- and medium-temperature model heaters. The capital costs of the control techniques range from \$227,000 for ND LNB's to \$2,580,000 for MD LNB's plus SCR. The TAC's range from \$36,100/yr for ND LNB's to \$463,000/yr for the MD LNB's plus SCR. These costs are the same for both distillate and residual oil-fired ND model heaters.

TABLE 6-2. COSTS OF CONTROL TECHNIQUES FOR ND  
NATURAL GAS-FIRED MODEL HEATERS (1991 \$)

Model heater capacity, MMBtu/hr	NO <sub>x</sub> control technique	Capital costs, \$	Capital recovery <sup>a</sup>	Annual costs, \$/yr			Total annual costs, \$/yr @ capacity factors: <sup>c</sup>					
				Operating and maintenance costs @ capacity factors: <sup>b</sup>			0.1	0.5	0.9	0.1	0.5	0.9
				0.1	0.5	0.9						
17	(ND) LNB	58,200	7,650	1,600	1,600	1,600	9,250	9,250	9,250			
	(MD) LNB	191,000	25,100	5,250	5,250	5,250	30,400	30,400	30,400			
	(ND) ULNB	62,500	8,220	1,720	1,720	1,720	9,940	9,940	9,940			
	(MD) ULNB	249,000	32,800	6,850	6,850	6,850	39,600	39,600	39,600			
	(ND) SNCR	155,000	20,300	4,490	5,420	6,360	24,800	25,700	26,700			
	(MD) SNCR	258,000	34,000	7,480	9,000	10,500	41,400	43,000	44,500			
	(MD) SCR	951,000	125,000	30,200	32,600	34,900	155,000	158,000	160,000			
	(MD) LNB + FGR	253,000	33,300	7,090	7,630	8,170	40,400	40,900	41,400			
	(ND) LNB + SNCR	213,000	28,000	6,090	7,020	7,960	34,100	35,000	35,900			
	(MD) LNB + SNCR	346,000	45,400	9,880	11,400	12,900	55,300	56,800	58,400			
	(MD) LNB + SCR	1,040,000	137,000	32,600	35,000	37,300	169,000	172,000	174,000			
36	(ND) LNB	92,600	12,200	2,550	2,550	2,550	14,700	14,700	14,700			
	(MD) LNB	302,000	39,600	8,290	8,290	8,290	47,900	47,900	47,900			
	(ND) ULNB	96,900	12,700	2,670	2,670	2,670	15,400	15,400	15,400			
	(MD) ULNB	308,000	40,500	8,470	8,470	8,470	49,000	49,000	49,000			
	(ND) SNCR	243,000	31,900	7,160	9,150	11,100	39,000	41,000	43,000			
	(MD) SNCR	405,000	53,300	11,900	14,400	16,900	65,200	67,700	70,100			
	(MD) SCR	1,500,000	198,000	49,900	54,900	59,900	247,000	252,000	257,000			
	(MD) LNB + FGR	399,000	52,500	11,300	12,400	13,500	63,700	64,800	66,000			
	(ND) LNB + SNCR	335,000	44,100	9,710	11,700	13,700	53,800	55,800	57,700			
	(MD) LNB + SNCR	544,000	71,500	15,800	19,000	22,200	87,300	90,500	93,700			
	(MD) LNB + SCR	1,640,000	216,000	53,700	58,700	63,700	270,000	275,000	280,000			
77	(ND) LNB	133,000	17,500	3,670	3,670	3,670	21,200	21,200	21,200			
	(MD) LNB	457,000	60,000	12,600	12,600	12,600	72,600	72,600	72,600			
	(ND) ULNB	138,000	18,100	3,790	3,790	3,790	21,900	21,900	21,900			
	(MD) ULNB	463,000	60,900	12,700	12,700	12,700	73,600	73,600	73,600			
	(ND) SNCR	383,000	50,300	11,600	15,800	20,100	61,900	66,100	70,400			
	(MD) SNCR	639,000	84,000	19,300	24,600	29,800	103,000	109,000	114,000			
	(MD) SCR	2,390,000	315,000	84,100	94,800	106,000	399,000	410,000	420,000			
	(MD) LNB + FGR	610,000	80,300	17,400	19,800	22,300	97,600	100,000	103,000			
	(ND) LNB + SNCR	516,000	67,900	15,300	19,500	23,700	83,100	87,300	91,600			
	(MD) LNB + SNCR	839,000	110,000	24,800	31,700	38,600	135,000	142,000	149,000			
	(MD) LNB + SCR	2,590,000	341,000	89,600	100,000	111,000	431,000	441,000	452,000			

TABLE 6-2. (continued)

Model heater capacity, MMBtu/hr	NO <sub>x</sub> control technique	Capital costs, \$	Capital recovery <sup>a</sup>	Annual costs, \$/yr			Total annual costs, \$/yr @ capacity factors: <sup>c</sup>					
				Operating and maintenance costs @ capacity factors: <sup>b</sup>			0.1	0.5	0.9	0.1	0.5	0.9
				0.1	0.5	0.9						
121	(ND) LNB	232,000	30,500	6,390	6,390	6,390	36,900	36,900	36,900			
	(MD) LNB	685,000	90,100	18,800	18,800	18,800	109,000	109,000	109,000			
	(ND) ULNB	237,000	31,100	6,510	6,510	6,510	37,600	37,600	37,600			
	(MD) ULNB	691,000	90,900	19,000	19,000	19,000	110,000	110,000	110,000			
	(ND) SNCR	502,000	66,000	15,500	22,100	28,800	81,500	88,100	94,800			
	(MD) SNCR	838,000	110,000	25,800	34,000	42,300	136,000	144,000	153,000			
	(MD) SCR	3,160,000	416,000	116,000	133,000	149,000	532,000	548,000	565,000			
	(MD) LNB + FGR	887,000	117,000	25,300	29,200	33,000	142,000	146,000	150,000			
	(ND) LNB + SNCR	734,000	96,500	21,900	28,500	35,200	118,000	125,000	132,000			
	(MD) LNB + SNCR	1,190,000	156,000	35,300	46,200	57,000	191,000	202,000	213,000			
	(MD) LNB + SCR	3,510,000	462,000	125,000	142,000	159,000	587,000	604,000	621,000			
186	(ND) LNB	346,000	45,500	9,520	9,520	9,520	55,000	55,000	55,000			
	(MD) LNB	955,000	126,000	26,300	26,300	26,300	152,000	152,000	152,000			
	(ND) ULNB	351,000	46,100	9,640	9,640	9,640	55,700	55,700	55,700			
	(MD) ULNB	961,000	126,000	26,400	26,400	26,400	153,000	153,000	153,000			
	(ND) SNCR	650,000	85,400	20,400	30,700	40,900	106,000	116,000	126,000			
	(MD) SNCR	1,090,000	143,000	34,000	46,700	59,400	177,000	189,000	202,000			
	(MD) SCR	4,130,000	543,000	158,000	183,000	209,000	700,000	726,000	752,000			
	(MD) LNB + FGR	1,220,000	160,000	34,900	40,800	46,600	195,000	201,000	207,000			
	(ND) LNB + SNCR	996,000	131,000	29,900	40,200	50,400	161,000	171,000	181,000			
	(MD) LNB + SNCR	1,600,000	211,000	48,300	64,900	81,500	259,000	276,000	292,000			
	(MD) LNB + SCR	4,650,000	611,000	172,000	198,000	224,000	783,000	809,000	835,000			

<sup>a</sup>Capital recovery = Capital cost x capital recovery factor.

<sup>b</sup>Operating and maintenance costs at operating capacities of 10 percent, 50 percent, and 90 percent.

<sup>c</sup>Total annual cost = Capital recovery + operating and maintenance cost.

TABLE 6-3. COSTS OF CONTROL TECHNIQUES FOR MD NATURAL GAS-FIRED MODEL HEATERS (1991 \$)

Model heater capacity, MMBtu/hr	NO <sub>x</sub> control technique	Capital costs, \$	Annual costs, \$/yr				Total annual costs, \$/yr @ capacity factors: <sup>c</sup>		
			Capital recovery <sup>a</sup>	Operating and maintenance costs @ capacity factors <sup>b</sup>			0.1	0.5	0.9
				0.1	0.5	0.9			
40	LNB	130,000	17,100	3,570	3,570	3,570	20,700	20,700	20,700
	ULNB	136,000	17,900	3,750	3,750	3,750	21,700	21,700	21,700
	SNCR	258,000	34,000	8,000	11,600	15,100	42,000	45,500	49,100
	SCR	1,430,000	188,000	48,800	54,400	59,900	237,000	242,000	248,000
	LNB + FGR	234,000	30,700	6,740	8,010	9,270	37,500	38,700	40,000
	LNB + SNCR	388,000	51,000	11,600	15,100	18,700	62,600	66,200	69,800
	LNB + SCR	1,560,000	205,000	52,400	57,900	63,500	257,000	263,000	269,000
77	LNB	282,000	37,100	7,750	7,750	7,750	44,800	44,800	44,800
	ULNB	288,000	37,900	7,930	7,930	7,930	45,800	45,800	45,800
	SNCR	383,000	50,300	12,200	19,100	26,000	62,600	69,400	76,300
	SCR	2,140,000	281,000	77,000	87,800	98,500	358,000	369,000	380,000
	LNB + FGR	436,000	57,300	12,600	15,000	17,400	69,900	72,300	74,700
	LNB + SNCR	665,000	87,400	20,000	26,900	33,800	107,000	114,000	121,000
	LNB + SCR	2,420,000	318,000	84,800	95,500	106,000	403,000	414,000	424,000
114	LNB	507,000	66,700	14,000	14,000	14,000	80,700	80,700	80,700
	ULNB	514,000	67,600	14,100	14,100	14,100	81,700	81,700	81,700
	SNCR	484,000	63,700	15,900	26,100	36,200	79,500	89,700	99,900
	SCR	2,720,000	358,000	102,000	118,000	134,000	460,000	476,000	492,000
	LNB + FGR	702,000	92,300	20,200	23,800	27,400	113,000	116,000	120,000
	LNB + SNCR	992,000	130,000	29,800	40,000	50,200	160,000	170,000	181,000
	LNB + SCR	3,230,000	425,000	116,000	132,000	148,000	541,000	557,000	573,000
174	LNB	541,000	71,200	14,900	14,900	14,900	86,100	86,100	86,100
	ULNB	548,000	72,000	15,100	15,100	15,100	87,100	87,100	87,100
	SNCR	624,000	82,100	21,100	36,600	52,200	103,000	119,000	134,000
	SCR	3,540,000	466,000	139,000	163,000	187,000	604,000	629,000	653,000
	LNB + FGR	792,000	104,000	23,200	28,600	34,100	127,000	133,000	138,000
	LNB + SNCR	1,170,000	153,000	35,900	51,500	67,000	189,000	205,000	220,000
	LNB + SCR	4,080,000	537,000	154,000	178,000	202,000	690,000	715,000	739,000

TABLE 6-3. (continued)

Model heater capacity, MMBtu/hr	NO <sub>x</sub> control technique	Capital costs, \$	Annual costs, \$/yr				Total annual costs, \$/yr @ capacity factors: <sup>c</sup>		
			Capital recovery: <sup>a</sup>	Operating and maintenance costs @ capacity factors: <sup>b</sup>			0.1	0.5	0.9
				0.1	0.5	0.9			
263	LNB	777,000	102,000	21,400	21,400	21,400	123,000	123,000	123,000
	ULNB	783,000	103,000	21,500	21,500	21,500	124,000	124,000	124,000
	SNCR	800,000	105,000	27,900	51,400	74,900	133,000	157,000	180,000
	SCR	4,580,000	603,000	188,000	225,000	262,000	791,000	828,000	864,000
	LNB + FGR	1,100,000	144,000	32,300	40,600	48,900	177,000	185,000	193,000
	LNB + SNCR	1,580,000	207,000	49,200	72,700	96,200	256,000	280,000	303,000
	LNB + SCR	5,360,000	705,000	210,000	246,000	283,000	915,000	951,000	983,000

<sup>a</sup>Capital recovery = Capital cost x capital recovery factor.

<sup>b</sup>Operating and maintenance costs at operating capacities of 10 percent, 50 percent, and 90 percent.

<sup>c</sup>Total annual cost = Capital recovery + operating and maintenance cost.

TABLE 6-4. COSTS OF CONTROL TECHNIQUES FOR ND OIL-FIRED MODEL HEATERS (1991 \$)

Model heater capacity and fuel type, MMBtu/hr	NO <sub>x</sub> control technique	Capital costs, \$	Capital recovery <sup>a</sup>	Annual costs, \$/yr <sup>b</sup>			Total annual costs, \$/yr @ capacity factors: <sup>c</sup>			
				Operating and maintenance costs @ capacity factors:						
				0.1	0.5	0.9	0.1	0.5	0.9	
69 Diatomite oil-fired	(ND) LNB	227,000	29,900	6,250	6,250	6,250	36,100	36,100	36,100	36,100
	(MD) LNB	581,000	76,400	16,000	16,000	16,000	92,400	92,400	92,400	92,400
	(ND) ULNB	232,000	30,500	6,370	6,370	6,370	36,800	36,800	36,800	36,800
	(MD) ULNB	588,000	77,300	16,200	16,200	16,200	93,400	93,400	93,400	93,400
	(ND) SNCR	358,000	47,100	31,100	20,900	29,700	78,300	68,000	76,800	76,800
	(MD) SNCR	598,000	78,700	19,400	31,100	42,700	98,100	110,000	121,000	121,000
	(MD) SCR	2,240,000	294,000	81,500	105,000	129,000	376,000	400,000	424,000	424,000
	(MD) LNB + FGR	725,000	95,300	20,500	22,700	24,800	116,000	118,000	120,000	120,000
	(ND) LNB + SNCR	586,000	77,000	18,300	27,100	35,900	95,300	104,000	113,000	113,000
	(MD) LNB + SNCR	939,000	124,000	28,800	40,400	52,100	152,000	164,000	176,000	176,000
	(MD) LNB + SCR	2,580,000	339,000	90,900	115,000	139,000	430,000	454,000	478,000	478,000
	69 Residual oil-fired	(ND) LNB	227,000	29,900	6,250	6,250	6,250	36,100	36,100	36,100
(MD) LNB		581,000	76,400	16,000	16,000	16,000	92,400	92,400	92,400	92,400
(ND) ULNB		232,000	30,500	6,370	6,370	6,370	36,800	36,800	36,800	36,800
(MD) ULNB		588,000	77,300	16,200	16,200	16,200	93,400	93,400	93,400	93,400
(ND) SNCR		358,000	47,100	12,900	25,100	37,400	60,000	72,300	84,500	84,500
(MD) SNCR		598,000	78,700	20,200	33,200	46,100	98,900	112,000	125,000	125,000
(MD) SCR		2,240,000	294,000	79,800	97,200	115,000	374,000	391,000	409,000	409,000
(MD) LNB + FGR		725,000	95,300	20,500	22,700	24,800	116,000	118,000	120,000	120,000
(ND) LNB + SNCR		586,000	77,000	19,200	31,400	43,600	96,200	108,000	121,000	121,000
(MD) LNB + SNCR		939,000	124,000	29,400	43,800	58,200	153,000	167,000	182,000	182,000
(MD) LNB + SCR		2,580,000	339,000	89,200	107,000	124,000	428,000	446,000	463,000	463,000

<sup>a</sup>Capital recovery = Capital cost \* capital recovery factor.

<sup>b</sup>Operating and maintenance costs at operating capacities of 10 percent, 50 percent, and 90 percent.

<sup>c</sup>Total annual cost = Capital recovery + operating and maintenance cost.

#### 6.2.4 Control Costs for MD Oil-Fired, Low- and Medium-Temperature Model Heaters

Table 6-5 presents the capital costs, annual costs, and TAC's for the MD oil-fired, low- and medium-temperature model heaters. The capital cost of the control techniques range from \$319,000 for LNB's to \$3,340,000 for LNB's plus SCR. The capital cost for both MD oil-fired heaters are the same. The TAC's range from \$50,700/yr for LNB's used on the distillate oil-fired heater to \$570,000 for LNB's plus SCR used on the residual oil-fired heater.

#### 6.2.5 Control Costs for the Olefins Pyrolysis Model Heaters

Table 6-6 present the capital costs, annual costs, and TAC for the ND olefins pyrolysis model heaters. The capital costs of the control techniques range from \$248,000 for LNB's to \$2,900,000 for LNB's plus SCR on both pyrolysis model heaters. The TAC's range from \$39,400/yr for LBN's on the natural gas-fired heater to \$512,000 for LBN's plus SCR on the high-hydrogen fuel gas-fired heater.

#### 6.2.6 Costs for ND-to-MD Conversion

Table 6-7 presents the capital, annual operating, and TAC of the ND-to-MD conversion for the model heaters. The capital costs range from \$104,000 to \$434,000; the annual operating cost range from \$2,860/yr to \$11,900/yr; and the TAC's range from \$16,500/yr to \$69,000/yr for the 17 and 185 MMBtu/hr natural gas-fired low- and medium-temperature heaters, respectively.

### 6.3 COST EFFECTIVENESS OF NO<sub>x</sub> CONTROLS FOR PROCESS HEATERS

This section presents the cost effectiveness for the control techniques presented in Section 6.2. The cost effectiveness, in dollars per ton of NO<sub>x</sub> removed (\$/ton), is calculated by dividing the TAC's by the annual NO<sub>x</sub> emission reduction, in tons.

Capacity factors of 0.1, 0.5, and 0.9 of heater operation, were included in the cost-effectiveness analysis. The capacity factor affects the operating costs but not the capital costs. The capacity factor also influences the tons per year of NO<sub>x</sub> produced by a process heater. For example, approximately



TABLE 6-5. COSTS OF CONTROL TECHNIQUES FOR MD OIL-FIRED HEATERS (1991 \$)

Model heater capacity and fuel type, MMBtu/hr	NO <sub>x</sub> control technique	Capital costs, \$	Capital recovery <sup>a</sup>	Annual costs, \$/yr			Total annual costs, \$/yr @ capacity factors: <sup>c</sup>		
				Operating and maintenance costs @ capacity factors: <sup>b</sup>					
				0.1	0.5	0.9	0.1	0.5	0.9
135 Distillate oil-fired	(MD) LNB	319,000	42,000	8,780	8,780	8,780	50,700	50,700	50,700
	(MD) ULNB	326,000	42,800	8,960	8,960	8,960	51,800	51,800	51,800
	SNCR	536,000	70,500	20,500	43,300	66,200	90,900	114,000	137,000
	SCR	3,130,000	411,000	89,900	105,000	121,000	501,000	516,000	532,000
	LNB + FGR	535,000	70,300	15,800	20,000	24,300	86,100	90,300	94,600
	LNB + SNCR	855,000	112,000	29,200	52,100	74,900	142,000	165,000	187,000
	LNB + SCR	3,340,000	440,000	95,800	111,000	127,000	536,000	551,000	566,000
135 Residual oil-fired	(MD) LNB	319,000	42,000	8,780	8,780	8,780	50,700	50,700	50,700
	(MD) ULNB	326,000	42,800	8,960	8,960	8,960	51,800	51,800	51,800
	SNCR	536,000	70,500	22,100	51,700	81,200	92,600	122,000	152,000
	SCR	3,130,000	411,000	90,200	107,000	124,000	501,000	518,000	535,000
	LNB + FGR	535,000	70,300	15,800	20,000	24,300	86,100	90,300	94,600
	LNB + SNCR	855,000	112,000	30,900	60,500	90,000	143,000	173,000	202,000
	LNB + SCR	3,340,000	440,000	96,200	113,000	130,000	536,000	553,000	570,000

<sup>a</sup>Capital recovery = Capital cost \* capital recovery factor.

<sup>b</sup>Operating and maintenance costs at operating capacities of 10 percent, 50 percent, and 90 percent.

<sup>c</sup>Total annual cost = Capital recovery + operating and maintenance cost.

TABLE 6-6. COSTS OF CONTROL TECHNIQUES FOR ND OLEFINS PYROLYSIS MODEL HEATERS (1991 \$)

Model heater capacity and fuel type, MMbtu/hr	NO <sub>x</sub> control technique	Capital costs, \$	Annual costs, \$/yr								
			Capital recovery <sup>a</sup>	Operating and maintenance costs @ capacity factors: <sup>b</sup>			Total annual costs, \$/yr @ capacity factors:				
				0.1	0.5	0.9	0.1	0.5	0.9		
84 Natural gas-fired	(ND) LNB	248,000	32,600	6,810	6,810	6,810	39,400	39,400	39,400	39,400	
	(MD) LNB	642,000	84,400	17,700	17,700	17,700	102,000	102,000	102,000	102,000	
	(ND) ULNB	252,000	33,100	6,930	6,930	6,930	40,100	40,100	40,100	40,100	
	(MD) ULNB	648,000	85,300	17,800	17,800	17,800	103,000	103,000	103,000	103,000	
	(ND) SNCR	403,000	53,000	12,300	17,100	21,900	70,100	70,100	74,900	74,900	
	(MD) SNCR	673,000	88,500	19,700	24,500	29,300	108,000	113,000	118,000	118,000	
	SCR	2,520,000	331,000	89,600	103,000	117,000	421,000	434,000	448,000	448,000	
	(MD) LNB + FGR	804,000	106,000	22,800	25,400	28,100	128,000	131,000	134,000	134,000	
	(ND) LNB + SNCR	651,000	85,600	19,100	23,900	28,700	105,000	109,000	114,000	114,000	
	(MD) LNB + SNCR	1,050,000	137,000	29,900	34,700	39,500	167,000	172,000	177,000	177,000	
	(MD) LNB + SCR	2,900,000	381,000	100,000	114,000	127,000	481,000	495,000	508,000	508,000	
	(ND) LNB	248,000	32,600	6,810	6,810	6,810	39,400	39,400	39,400	39,400	
	(MD) LNB	642,000	84,400	17,700	17,700	17,700	102,000	102,000	102,000	102,000	
	(ND) ULNB	252,000	33,100	6,930	6,930	6,930	40,100	40,100	40,100	40,100	
(MD) ULNB	648,000	85,300	17,800	17,800	17,800	103,000	103,000	103,000	103,000		
(ND) SNCR	403,000	53,000	12,500	18,400	24,200	65,600	71,400	77,300	77,300		
(MD) SNCR	673,000	88,500	20,000	25,800	31,700	109,000	114,000	120,000	120,000		
SCR	2,520,000	331,000	90,100	105,000	121,000	421,000	436,000	452,000	452,000		
(MD) LNB + FGR	804,000	106,000	22,800	25,400	28,100	128,000	131,000	134,000	134,000		
(ND) LNB + SNCR	651,000	85,600	19,400	25,200	31,100	105,000	111,000	117,000	117,000		
(MD) LNB + SNCR	1,050,000	137,000	30,200	36,100	41,900	168,000	173,000	179,000	179,000		
(MD) LNB + SCR	2,900,000	381,000	100,000	116,000	131,000	481,000	497,000	512,000	512,000		

<sup>a</sup>Capital recovery = Capital cost \* capital recovery factor.

<sup>b</sup>Operating and maintenance costs at operating capacities of 10 percent, 50 percent, and 90 percent.

<sup>c</sup>Total annual cost = Capital recovery + operating and maintenance cost.

TABLE 6-7. ND-TO-MD CONVERSION COSTS FOR THE ND MODEL  
HEATERS (1991 \$)

Model heater capacity, MMBtu/hr	Capital cost, 1991 US \$	Capital recovery, 1991 US \$/yr	Annual operating costs, 1991 US \$/yr	Total annual costs, 1991 US \$/yr
ND NATURAL GAS-FIRED HEATERS				
17	104,000	13,600	2,860	16,500
36	163,000	21,400	4,480	25,900
77	257,000	33,800	7,070	40,900
121	336,000	442,000	9,240	53,400
185	434,000	57,100	11,900	69,000
ND OIL-FIRED HEATERS				
69	240,000	31,600	6,400	38,000
ND OLEFINS PYROLYSIS HEATERS				
84	270,000	35,500	7,430	42,900

90 percent less  $\text{NO}_x$  is produced by a heater operating at a capacity factor of 0.1 as opposed to 1.0.

Cost effectiveness for ND natural gas-fired heaters is presented in Table 6-8. The cost-effectiveness range at a capacity factor of 0.9 is from \$981/ton for ND ULNB's on the 77 MMBtu/hr heater to \$16,200/ton for SCR on the 17 MMBtu/hr heater. The cost-effectiveness range for MD natural gas-fired heaters is shown in Table 6-9. At a capacity factor of 0.9, the cost effectiveness ranges from \$813/ton for ULNB's on the 263 MMBtu/hr heater to \$10,600/ton for SCR on the 40 MMBtu/hr heater.

The cost-effectiveness range for oil-fired ND heaters is shown in Table 6-10. For a capacity factor of 0.9, the cost effectiveness ranges from \$419/ton for ND ULNB's on the residual oil-fired heater to \$6,490/ton for SCR on the distillate oil-fired heater. The cost-effectiveness range for oil-fired MD heaters, shown in Table 6-11, is from \$245/ton for ULNB's on the residual oil-fired heater to \$4,160/ton for SCR on the distillate oil-fired heater at a capacity factor of 0.9.

The cost-effectiveness range for the ND olefins pyrolysis model heaters is shown in Table 6-12. At a capacity factor of 0.9, the cost effectiveness ranges from \$1,490/ton for MD ULNB's on the high-hydrogen fuel gas-fired heater to \$14,100/ton for LNB+SCR on the natural gas-fired heater.

The cost effectiveness of each control technique for the model heaters generally increases from ULNB to LNB, to LNB plus FGR, to SNCR, to LNB plus SNCR, to LNB plus SCR, to SCR. The cost-effectiveness values for the control techniques applied to the smaller model heaters are generally higher in comparison to the same control techniques applied to the larger heaters. This difference represents an economy of scale because for a given percent reduction, the quantity of  $\text{NO}_x$  emissions removed per year (tons/yr) from the smaller model heaters was lower than from other model heaters.

Table 6-13 is a summary of the cost effectiveness of selected  $\text{NO}_x$  emission control techniques as presented by the

TABLE 6-8. COST EFFECTIVENESS OF CONTROL TECHNIQUES FOR ND NATURAL GAS-FIRED MODEL HEATERS (1991 \$)

Model heater capacity, MMBtu/hr	NO <sub>x</sub> control technique	Uncontrolled NO <sub>x</sub> emissions, ton/yr @ capacity factors <sup>a</sup>			Total effective reduction, percent	NO <sub>x</sub> reduction, ton/yr @ capacity factors:			Total annual costs, \$/yr @ capacity factors			Cost effectiveness, \$/ton @ capacity factors <sup>a</sup>		
		0.1	0.5	0.9		0.1	0.5	0.9	0.1	0.5	0.9	0.1	0.5	0.9
		17	(ND) LNB	0.730		3.65	6.57	50	0.365	1.82	3.28	9,250	9,250	9,250
	(MD) LNB	1.47	7.33	13.2	50	0.733	3.67	6.60	30,400	30,400	30,400	41,400	8,280	4,600
	(ND) ULNB	0.730	3.65	6.57	75	0.547	2.74	4.93	9,940	9,940	9,940	18,200	3,630	2,020
	(MD) ULNB	1.47	7.33	13.2	75	1.10	5.50	9.90	39,600	39,600	39,600	36,000	7,200	4,000
	(ND) SNCR	0.730	3.65	6.57	60	0.438	2.19	3.94	24,800	25,700	26,700	56,700	11,800	6,770
	(MD) SNCR	1.47	7.33	13.2	60	0.880	4.40	7.92	41,400	43,000	44,500	47,100	9,760	5,610
	(MD) SCR	1.47	7.33	13.2	75	1.10	5.50	9.90	155,000	158,000	160,000	141,000	28,700	16,200
	(MD) LNB + FGR	1.47	7.33	13.2	55	0.807	4.03	7.26	40,400	40,900	41,400	50,000	10,100	5,710
	(ND) LNB + SNCR	0.730	3.65	6.57	80	0.584	2.92	5.25	34,100	35,000	35,900	58,400	12,000	6,840
	(MD) LNB + SNCR	1.47	7.33	13.2	80	1.17	5.87	10.6	55,300	56,800	58,400	47,100	9,690	5,530
	(MD) LNB + SCR	1.47	7.33	13.2	88	1.28	6.42	11.6	169,000	172,000	174,000	132,000	26,700	15,100
36	(ND) LNB	1.55	7.73	13.9	50	0.773	3.86	6.95	14,700	14,700	14,700	19,100	3,810	2,120
	(MD) LNB	3.11	15.5	28.0	50	1.55	7.77	14.0	47,900	47,900	47,900	30,900	6,170	3,430
	(ND) ULNB	1.55	7.73	13.9	75	1.16	5.79	10.4	15,400	15,400	15,400	13,300	2,660	1,480
	(MD) ULNB	3.11	15.5	28.0	75	2.33	11.6	21.0	49,000	49,000	49,000	21,000	4,200	2,330
	(ND) SNCR	1.55	7.73	13.9	60	0.927	4.64	8.34	39,000	41,000	43,000	42,100	8,850	5,150
	(MD) SNCR	3.11	15.5	28.0	60	1.86	9.32	16.8	65,200	67,700	70,100	35,000	7,260	4,180
	(MD) SCR	3.11	15.5	28.0	75	2.33	11.6	21.0	247,000	252,000	257,000	106,000	21,700	12,300
	(MD) LNB + FGR	3.11	15.5	28.0	55	1.71	8.54	15.4	63,700	64,800	66,000	37,300	7,590	4,290
	(ND) LNB + SNCR	1.55	7.73	13.9	80	1.24	6.18	11.1	53,800	55,800	57,700	43,500	9,020	5,190
	(MD) LNB + SNCR	3.11	15.5	28.0	80	2.49	12.4	22.4	87,300	90,500	93,700	35,100	7,280	4,190
	(MD) LNB + SCR	3.11	15.5	28.0	88	2.72	13.6	24.5	270,000	275,000	280,000	99,200	20,200	11,400

TABLE 6-8. (continued)

Modcl heater capacity, MMbtu/hr	NO <sub>x</sub> control technique	Uncontrolled NO <sub>x</sub> emissions, ton/yr @ capacity factors:		Total effective reduction, percent	NO <sub>x</sub> reduction, ton/yr @ capacity factors:			Total annual costs, \$/yr @ capacity factors:			Cost effectiveness, \$/ton @ capacity factors: <sup>a</sup>				
		0.1	0.5		0.9	0.1	0.5	0.9	0.1	0.5	0.9	0.1	0.5	0.9	
															0.1
77	(ND) LNB	3.31	16.5	29.7	50	1.65	8.26	14.9	21,200	21,200	21,200	12,800	2,570	1,430	
	(MD) LNB	6.64	33.2	59.8	50	3.32	16.6	29.9	72,600	72,600	72,600	21,900	4,370	2,430	
	(ND) ULNB	3.31	16.5	29.7	75	2.48	12.4	22.3	21,900	21,900	21,900	8,830	1,770	981	
	(MD) ULNB	6.64	33.2	59.8	75	4.98	24.9	44.8	73,600	73,600	73,600	14,800	2,950	1,640	
	(ND) SNCR	3.31	16.5	29.7	60	1.98	9.92	17.8	61,900	66,100	70,400	31,200	6,670	3,940	
	(MD) SNCR	6.64	33.2	59.8	60	3.99	19.9	35.9	103,000	109,000	114,000	25,900	5,450	3,170	
	(MD) SCR	6.64	33.2	59.8	75	4.98	24.9	44.8	399,000	410,000	420,000	80,100	16,400	9,370	
	(MD) LNB + FGR	6.64	33.2	59.8	55	3.65	18.3	32.9	97,600	100,000	103,000	26,700	5,480	3,120	
	(ND) LNB + SNCR	3.31	16.5	29.7	80	2.64	13.2	23.8	83,100	87,300	91,600	31,400	6,610	3,850	
	(MD) LNB + SNCR	6.64	33.2	59.8	80	5.32	26.6	47.8	135,000	142,000	149,000	25,400	5,340	3,110	
	(MD) LNB + SCR	6.64	33.2	59.8	88	5.81	29.1	52.3	431,000	441,000	452,000	74,100	15,200	8,640	
	121	(ND) LNB	5.19	26.0	46.7	50	2.60	13.0	23.4	36,900	36,900	36,900	14,200	2,840	1,580
		(MD) LNB	10.4	52.2	94.0	50	5.22	26.1	47.0	109,000	109,000	109,000	20,900	4,170	2,320
		(ND) ULNB	5.19	26.0	46.7	75	3.90	19.5	35.1	37,600	37,600	37,600	9,660	1,930	1,070
(MD) ULNB		10.4	52.2	94.0	75	7.83	39.2	70.5	110,000	110,000	110,000	14,000	2,810	1,560	
(ND) SNCR		5.19	26.0	46.7	60	3.12	15.6	28.0	81,500	88,100	94,800	26,100	5,660	3,380	
(MD) SNCR		10.4	52.2	94.0	60	6.26	31.3	56.4	136,000	144,000	153,000	21,700	4,610	2,710	
(MD) SCR		10.4	52.2	94.0	75	7.83	39.2	70.5	532,000	548,000	565,000	67,900	14,000	8,020	
(MD) LNB + FGR		10.4	52.2	94.0	55	5.74	28.7	51.7	142,000	146,000	150,000	24,700	5,080	2,890	
(ND) LNB + SNCR		5.19	26.0	46.7	80	4.16	20.8	37.4	118,000	125,000	132,000	28,500	6,020	3,520	
(MD) LNB + SNCR		10.4	52.2	94.0	80	8.35	41.8	75.2	191,000	202,000	213,000	22,900	4,840	2,830	
(MD) LNB + SCR	10.4	52.2	94.0	88	9.14	45.7	82.2	587,000	604,000	621,000	64,300	13,200	7,550		

TABLE 6-8. (continued)

Model heater capacity, MMBtu/hr	NO <sub>x</sub> control technique	Uncontrolled NO <sub>x</sub> emissions, ton/yr @ capacity factors:			Total effective reduction, percent	NO <sub>x</sub> reduction, ton/yr @ capacity factors:			Total annual cost, \$/yr @ capacity factors:			Cost effectiveness, \$/ton @ capacity factors: <sup>a</sup>		
		0.1	0.5	0.9		0.1	0.5	0.9	0.1	0.5	0.9	0.1	0.5	0.9
186	(ND) LNB	7.98	39.9	71.9	50	3.99	20.0	35.9	55,000	55,000	55,000	13,800	2,760	1,530
	(MD) LNB	16.0	80.2	144	50	8.02	40.1	72.2	152,000	152,000	152,000	18,900	3,780	2,100
	(ND) ULNB	7.98	39.9	71.9	75	5.99	29.9	53.9	55,700	55,700	55,700	9,310	1,860	1,030
	(MD) ULNB	16.0	80.2	144	75	12.0	60.2	108	153,000	153,000	153,000	12,700	2,540	1,410
	(ND) SNCR	7.98	39.9	71.9	60	4.79	24.0	43.1	106,000	116,000	126,000	22,100	4,850	2,930
	(MD) SNCR	16.0	80.2	144	60	9.63	48.1	86.7	177,000	189,000	202,000	18,300	3,930	2,330
	(MD) SCR	16.0	80.2	144	75	12.0	60.2	108	700,000	726,000	752,000	58,200	12,100	6,940
	(MD) LNB + FGR	16.0	80.2	144	55	8.83	44.1	79.4	195,000	201,000	207,000	22,100	4,550	2,600
	(ND) LNB + SNCR	7.98	39.9	71.9	80	6.39	31.9	57.5	161,000	171,000	181,000	25,200	5,360	3,150
	(MD) LNB + SNCR	16.0	80.2	144	80	12.8	64.2	116	259,000	276,000	292,000	20,200	4,300	2,530
	(MD) LNB + SCR	16.0	80.2	144	88	14.0	70.2	126	783,000	809,000	835,000	55,700	11,500	6,600

<sup>a</sup>Cost effectiveness = Total annual cost/NO<sub>x</sub> reductions.

TABLE 6-9. COST EFFECTIVENESS OF CONTROL TECHNIQUES FOR MD NATURAL GAS-FIRED MODEL HEATERS (1991 \$)

Model heater capacity, MMBtu/hr	NO <sub>x</sub> control technique	Uncontrolled NO <sub>x</sub> emissions, ton/yr @ capacity factors:			Total effective reductions, percent	NO <sub>x</sub> reductions, ton/yr @ capacity factors:			Total annual costs, \$/yr @ capacity factors:			Cost effectiveness, \$/ton @ capacity factors: <sup>a</sup>		
		0.1	0.5	0.9		0.1	0.5	0.9	0.1	0.5	0.9	0.1	0.5	0.9
		40	LNB	3.45		17.3	31.1	50	1.73	8.63	15.5	20,700	20,700	20,700
	ULNB	3.45	17.3	31.1	75	2.59	12.9	23.3	21,700	21,700	21,700	8,380	1,680	931
	SNCR	3.45	17.3	31.1	60	2.07	10.4	18.6	42,000	45,500	49,100	20,300	4,400	2,640
	SCR	3.45	17.3	31.1	75	2.59	12.9	23.3	237,000	242,000	248,000	91,500	18,700	10,600
	LNB + FGR	3.45	17.3	31.1	55	1.90	9.49	17.1	37,500	38,700	40,000	19,700	4,080	2,340
	LNB + SNCR	3.45	17.3	31.1	80	2.76	13.8	24.9	62,600	66,200	69,800	22,700	4,790	2,810
	LNB + SCR	3.45	17.3	31.1	88	3.02	15.1	27.2	257,000	263,000	269,000	85,200	17,400	9,880
77	LNB	6.64	33.2	59.8	50	3.32	16.6	29.9	44,800	44,800	44,800	13,500	2,700	1,500
	ULNB	6.64	33.2	59.8	75	4.98	24.9	44.8	45,800	45,800	45,800	9,200	1,840	1,020
	SNCR	6.64	33.2	59.8	60	3.99	19.9	35.9	62,600	69,400	76,300	15,700	3,480	2,130
	SCR	6.64	33.2	59.8	75	4.98	24.9	44.8	358,000	369,000	380,000	71,900	14,800	8,460
	LNB + FGR	6.64	33.2	59.8	55	3.65	18.3	32.9	69,900	72,300	74,700	19,100	3,960	2,270
	LNB + SNCR	6.64	33.2	59.8	80	5.32	26.6	47.8	107,000	114,000	121,000	20,200	4,300	2,530
	LNB + SCR	6.64	33.2	59.8	88	5.81	29.1	52.3	403,000	414,000	424,000	62,300	14,200	8,110
114	LNB	9.84	49.2	88.5	50	4.92	24.6	44.3	80,700	80,700	80,700	16,400	3,280	1,820
	ULNB	9.84	49.2	88.5	75	7.38	36.9	66.4	81,700	81,700	81,700	11,100	2,210	1,230
	SNCR	9.84	49.2	88.5	60	5.90	29.5	53.1	79,500	89,700	99,900	13,500	3,040	1,880
	SCR	9.84	49.2	88.5	75	7.38	36.9	66.4	460,000	476,000	492,000	62,400	12,900	7,410
	LNB + FGR	9.84	49.2	88.5	55	5.41	27.1	48.7	113,000	116,000	120,000	20,800	4,290	2,460
	LNB + SNCR	9.84	49.2	88.5	80	7.87	39.3	70.8	160,000	170,000	181,000	20,400	4,330	2,550
	LNB + SCR	9.84	49.2	88.5	88	8.61	43.0	77.5	541,000	557,000	573,000	62,800	12,900	7,390
174	LNB	15.0	75.1	135	50	7.51	37.5	67.6	86,100	86,100	86,100	11,500	2,290	1,270
	ULNB	15.0	75.1	135	75	11.3	56.3	101	87,100	87,100	87,100	7,730	1,550	859
	SNCR	15.0	75.1	135	60	9.01	45.0	81.1	103,000	119,000	134,000	11,400	2,630	1,660
	SCR	15.0	75.1	135	75	11.3	56.3	101	604,000	629,000	653,000	53,700	11,200	6,440
	LNB + FGR	15.0	75.1	135	55	8.26	41.3	74.3	127,000	133,000	138,000	15,400	3,220	1,860
	LNB + SNCR	15.0	75.1	135	80	12.0	60.1	108	189,000	205,000	220,000	15,700	3,410	2,040
	LNB + SCR	15.0	75.1	135	88	13.1	65.7	118	690,000	715,000	739,000	52,600	10,900	6,250



TABLE 6-9. (continued)

Model heater capacity, MMBtu/hr	NO <sub>x</sub> control technique	Uncontrolled NO <sub>x</sub> emissions, ton/yr @ capacity factors:			Total effective reductions, percent	NO <sub>x</sub> reductions, ton/yr @ capacity factors:			Total annual costs, \$/yr @ capacity factors:			Cost effectiveness, \$/ton @ capacity factors: <sup>a</sup>		
		0.1	0.5	0.9		0.1	0.5	0.9	0.1	0.5	0.9	0.1	0.5	0.9
263	LNB	22.7	113	204	50	11.3	56.7	102	123,000	123,000	123,000	10,900	2,180	1,210
	ULNB	22.7	113	204	75	17.0	85.1	153	124,000	124,000	124,000	7,310	1,460	813
	SNCR	22.7	113	204	60	13.6	68.1	123	133,000	157,000	180,000	9,770	2,300	1,470
	SCR	22.7	113	204	75	17.0	85.1	153	791,000	828,000	864,000	46,500	9,730	5,640
	LNB + FGR	22.7	113	204	55	12.5	62.4	112	177,000	185,000	193,000	14,200	2,960	1,720
	LNB + SNCR	22.7	113	204	80	18.2	90.8	163	256,000	280,000	303,000	14,100	3,080	1,860
	LNB + SCR	22.7	113	204	88	19.9	99.3	179	915,000	951,000	988,000	46,100	9,580	5,530

<sup>a</sup>Cost effectiveness = Total annual cost/NO<sub>x</sub> reductions.

TABLE 6-10. COST EFFECTIVENESS OF CONTROL TECHNIQUES FOR ND OIL-FIRED MODEL HEATERS (1991 \$)

Model heater capacity and fuel type, MMBtu/hr	NO <sub>x</sub> control technique	Uncontrolled NO <sub>x</sub> emission, ton/yr @ capacity factors <sup>a</sup>			Total effective reduction, percent	NO <sub>x</sub> reductions, ton/yr @ capacity factors <sup>a</sup>			Total annual costs, \$/yr @ capacity factors <sup>a</sup>			Cost effectiveness, \$/ton @ capacity factors <sup>a</sup>		
		0.1	0.5	0.9		0.1	0.5	0.9	0.1	0.5	0.9	0.1	0.5	0.9
69 Distillate oil-fired	(ND) LNB	6.04	30.2	54.4	40	2.39	11.9	21.5	36,100	36,100	36,100	15,100	3,030	1,680
	(MD) LNB	9.67	48.4	87.0	45	4.38	21.9	39.4	92,400	92,400	92,400	21,100	4,220	2,340
	(ND) ULNB	6.04	30.2	54.4	76	4.59	22.9	41.3	36,800	36,800	36,800	8,030	1,610	892
	(MD) ULNB	9.67	48.4	87.0	74	7.20	36.0	64.8	93,400	93,400	93,400	13,000	2,600	1,440
	(ND) SNCR	6.04	30.2	54.4	60	3.63	18.1	32.6	78,300	68,000	76,800	16,300	3,750	2,350
	(MD) SNCR	9.67	48.4	87.0	60	5.80	29.0	52.2	98,100	110,000	121,000	16,900	3,780	2,330
	(MD) SCR	9.67	48.4	87.0	75	7.25	36.3	65.3	376,000	400,000	424,000	51,800	11,000	6,490
	(MD) LNB + FGR	9.67	48.4	87.0	48	4.59	23.0	41.3	116,000	118,000	120,000	25,200	5,140	2,910
	(ND) LNB + SNCR	6.04	30.2	54.4	76	4.58	22.9	41.2	95,300	104,000	113,000	20,800	4,540	2,740
	(MD) LNB + SNCR	9.67	48.4	87.0	78	7.56	37.8	68.0	152,000	164,000	176,000	20,200	4,340	2,580
	(MD) LNB + SCR	9.67	48.4	87.0	86	8.35	41.7	75.1	430,000	454,000	478,000	51,500	10,900	6,360
	69 Residual oil-fired	(ND) LNB	12.7	63.5	114	27	3.38	16.9	30.5	36,100	36,100	36,100	10,700	2,140
(MD) LNB		16.3	81.6	147	37	6.04	30.2	54.4	92,400	92,400	92,400	15,300	3,060	1,700
(ND) ULNB		12.7	63.5	114	77	9.77	48.9	88.0	36,800	36,800	36,800	3,770	753	419
(MD) ULNB		16.3	81.6	147	73	12.0	59.9	108	93,400	93,400	93,400	7,790	1,560	866
(ND) SNCR		12.7	63.5	114	60	7.62	38.1	68.5	60,000	72,300	84,500	7,880	1,900	1,230
(MD) SNCR		16.3	81.6	147	60	9.79	49.0	88.1	98,900	112,000	125,000	10,100	2,280	1,420
(MD) SCR		16.3	81.6	147	75	12.2	61.2	110	374,000	391,000	409,000	30,600	6,400	3,710
(MD) LNB + FGR		16.3	81.6	147	34	5.59	28.0	50.3	116,000	118,000	120,000	20,700	4,220	2,390
(ND) LNB + SNCR		12.7	63.5	114	71	8.97	44.8	80.7	96,200	108,000	121,000	10,700	2,420	1,490
(MD) LNB + SNCR		16.3	81.6	147	75	12.2	61.0	110	153,000	167,000	182,000	12,500	2,740	1,650
(MD) LNB + SCR		16.3	81.6	147	84	13.8	68.8	124	428,000	446,000	463,000	31,200	6,480	3,740

<sup>a</sup>Cost effectiveness = Total annual cost/NO<sub>x</sub> reductions

TABLE 6-11. COST EFFECTIVENESS OF CONTROL TECHNIQUES  
FOR MD OIL-FIRED MODEL HEATERS (1991 \$)

Model heater capacity, MMBtu/hr	NO <sub>x</sub> control technique	Uncontrolled NO <sub>x</sub> emissions, ton/yr @ capacity factors:			Total effective reduction, percent	NO <sub>x</sub> reductions, ton/yr @ capacity factors:			Total annual costs, \$/yr @ capacity factors:			Cost effectiveness, ton/yr @ capacity factors: <sup>a</sup>								
		0.1				0.5			0.9			0.1			0.5			0.9		
		0.1	0.5	0.9		0.1	0.5	0.9	0.1	0.5	0.9	0.1	0.5	0.9	0.1	0.5	0.9			
135	(MD) LNB	18.9	94.6	170	45	8.57	42.9	77.2	50,700	50,700	50,700	50,700	5,920	1,180	658					
	(MD) ULNB	18.9	94.6	170	74	14.1	70.4	127	51,800	51,800	51,800	3,680	735	408						
	SNCR	18.9	94.6	170	60	11.4	56.8	102	90,900	114,000	137,000	8,010	2,000	1,340						
	SCR	18.9	94.6	170	75	14.2	71.0	128	501,000	516,000	532,000	35,300	7,280	4,160						
	LNB + FGR	18.9	94.6	170	48	8.99	44.9	80.9	86,100	90,300	94,600	9,570	2,010	1,170						
	LNB + SNCR	18.9	94.6	170	78	14.8	73.9	133	142,000	165,000	187,000	9,580	2,230	1,410						
	LNB + SCR	18.9	94.6	170	92	17.4	86.8	156	536,000	551,000	566,000	30,800	6,340	3,620						
	(MD) LNB	31.9	160	287	37	11.8	59.1	106	50,700	50,700	50,700	4,290	858	477						
	(MD) ULNB	31.9	160	287	73	23.5	117	211	51,800	51,800	51,800	2,210	442	245						
	SNCR	31.9	160	287	60	19.2	95.8	172	92,600	122,000	152,000	4,830	1,280	880						
135	SCR	31.9	160	287	75	23.9	120	216	501,000	518,000	535,000	20,900	4,330	2,480						
	LNB + FGR	31.9	160	287	34	10.9	54.7	98.5	86,100	90,300	94,600	7,870	1,650	961						
	LNB + SNCR	31.9	160	287	75	23.9	119	215	143,000	173,000	202,000	6,000	1,450	942						
	LNB + SCR	31.9	160	287	91	28.9	145	260	536,000	553,000	570,000	18,500	3,820	2,190						

<sup>a</sup>Cost effectiveness = Total annual cost/NO<sub>x</sub> reductions.

TABLE 6-12. COST EFFECTIVENESS OF CONTROL TECHNIQUES FOR ND PYROLYSIS MODEL HEATERS (1991 \$)

Model heater capacity and fuel type, MMBtu/hr	NO <sub>x</sub> control technique	Uncontrolled emissions, ton/yr @ capacity factors:		Total effective reduction, percent	Controlled emissions, ton/yr @ capacity factors:		Reduction, ton/yr @ capacity factors:			Total annual costs, \$/yr @ capacity factors:			Cost effectiveness, \$/ton removed, @ capacity factors: <sup>a</sup>		
		0.1	0.5		0.9	0.1	0.5	0.9	0.1	0.5	0.9	0.1	0.5	0.9	
84 natural gas	(ND) LNB	4.97	24.8	44.7	3.73	18.6	33.5	1.24	6.21	11.2	39,400	39,400	31,700	6,350	3,530
	(MD) LNB	4.97	24.8	44.7	3.73	18.6	33.5	1.24	6.21	11.2	102,000	102,000	82,200	16,400	9,130
	(ND) ULNB	4.97	24.8	44.7	2.48	12.4	22.4	2.48	12.4	22.4	40,100	40,100	16,100	3,230	1,790
	(MD) ULNB	4.97	24.8	44.7	2.48	12.4	22.4	2.48	12.4	22.4	103,000	103,000	41,500	8,300	4,610
	(ND) SNCR	4.97	24.8	44.7	1.99	9.93	17.9	2.98	14.9	26.8	65,500	71,200	22,000	4,780	2,870
	(MD) SNCR	4.97	24.8	44.7	1.99	9.93	17.9	2.98	14.9	26.8	108,000	114,000	36,400	7,660	4,470
	SCR	4.97	24.8	44.7	1.24	6.21	11.2	3.73	18.6	33.5	421,000	436,000	113,000	23,400	13,500
	(MD) LNB + FOR	4.97	24.8	44.7	2.24	11.2	20.1	2.73	13.7	24.6	128,000	131,000	47,000	9,600	5,440
	(ND) LNB + SNCR	4.97	24.8	44.7	1.49	7.45	13.4	3.48	17.4	31.3	105,000	111,000	30,200	6,360	3,720
	(MD) LNB + SNCR	4.97	24.8	44.7	1.49	7.45	13.4	3.48	17.4	31.3	168,000	173,000	48,200	9,970	5,720
(MD) LNB + SCR	4.97	24.8	44.7	0.93	4.66	8.38	4.04	20.2	36.3	481,000	497,000	119,000	24,600	14,100	
84 high hydrogen fuel gas	(ND) LNB	5.96	29.8	53.6	4.47	22.4	40.2	1.49	7.45	13.4	39,400	39,400	26,400	5,290	2,940
	(MD) LNB	5.96	29.8	53.6	4.47	22.4	40.2	1.49	7.45	13.4	102,000	102,000	68,500	13,700	7,610
	(ND) ULNB	5.96	29.8	53.6	2.98	14.9	26.8	2.98	14.9	26.8	40,100	40,100	13,400	2,690	1,490
	(MD) ULNB	5.96	29.8	53.6	2.98	14.9	26.8	2.98	14.9	26.8	103,000	103,000	34,600	6,920	3,840
	(ND) SNCR	5.96	29.8	53.6	2.38	11.9	21.5	3.58	17.9	32.2	65,700	72,200	18,400	4,040	2,450
	(MD) SNCR	5.96	29.8	53.6	2.38	11.9	21.5	3.58	17.9	32.2	109,000	115,000	30,400	6,440	3,780
	SCR	5.96	29.8	53.6	1.49	7.45	13.4	4.47	22.4	40.2	421,000	438,000	94,300	19,600	11,300
	(MD) LNB + FOR	5.96	29.8	53.6	2.68	13.4	24.1	3.28	16.4	29.5	128,000	131,000	39,200	8,000	4,530
	(ND) LNB + SNCR	5.96	29.8	53.6	1.79	8.94	16.1	4.17	20.9	37.5	105,000	112,000	25,200	5,350	3,140
	(MD) LNB + SNCR	5.96	29.8	53.6	1.79	8.94	16.1	4.17	20.9	37.5	168,000	174,000	40,200	8,350	4,810
(MD) LNB + SCR	5.96	29.8	53.6	1.12	5.59	10.1	4.84	24.2	43.6	482,000	498,000	99,500	20,600	11,800	

<sup>a</sup>Cost effectiveness = Total annual cost/NO<sub>x</sub> reductions

TABLE 6-13. CARB COST EFFECTIVENESS FOR NO<sub>x</sub> EMISSION CONTROL TECHNIQUES (1991 \$)<sup>12</sup>

Control technology	Annual capacity factor, percent	Unit size range, MMBtu/hr	Cost effectiveness range, thousand/ton NO <sub>x</sub> <sup>a</sup>
Low-NO <sub>x</sub> burners	10	3.5 to 150	2.61 to 30.6
	50		0.570 to 7.25
	90		0.340 to 4.53
Flue gas recirculation	10	3.5 to 350	7.71 to 32.9
	50		1.81 to 7.71
	90		1.13 to 4.19
Selective noncatalytic reduction	10	50 to 375	2.61 to 22.7
	50		1.70 to 6.80
	90		1.47 to 4.31
Selective catalytic reduction	10	50 to 350	27.2 to 74.8
	50		6.80 to 15.9
	90		4.53 to 10.2

<sup>a</sup>Escalated from 1986 \$ to 1991 \$ using the Chemical Engineering plant cost index.<sup>3</sup>

California Air Resources Board (CARB).<sup>12</sup> The accuracy of the cost methodologies used in this study is estimated to be 30 percent plus or minus the actual cost.<sup>1</sup> The cost-effectiveness values of the control techniques for the model heaters are generally consistent with the ranges given in Table 6-13.

When comparing the cost effectiveness of combination control techniques in Table 6-13 to those in Tables 6-8 through 6-12, it is necessary to add the cost effectiveness of each component in Table 6-13. For example, the cost effectiveness of LNB's and SCR should be added to yield the total cost effectiveness of LNB's combined with SCR.

#### 6.4 COST EFFECTIVENESS OF RADIANT BURNERS

This section presents the costs and cost-effectiveness values for a process heater using radiant burners. Data are insufficient to allow the development of model heaters with radiant burners. However, cost data for a new installation were provided for a 6 MMBtu/hr process heater using radiant burners. Retrofit costs are expected to be much higher for most process heater applications due to the major construction cost of modifying existing process heaters to accept radiant burners.<sup>5</sup> Refer to Section 5.1.8 for a discussion of radiant burners.

Emission reduction data for the 6 MMBtu/hr heater were presented in Table 5-6. The capital costs, capital recovery, annual costs, and cost-effectiveness values are presented in Table 6-14. The capital cost for radiant burners for this heater is \$38,000. The annual costs range from \$12,600/yr to \$8,280/yr for capacity factors of 0.9 and 0.3, respectively. The cost effectiveness range from \$7,600/ton to \$17,600/ton for capacity factors of 0.9 and 0.3, respectively.<sup>5</sup>

TABLE 6-14. RADIANT BURNER COST EFFECTIVENESS<sup>5</sup>

Heater capacity, MMBtu/hr	Capacity factor	Emission reduction, tons/yr <sup>a</sup>	Cost, \$ 1991				Cost effectiveness, \$/ton
			Capital	Capital recovery <sup>b</sup>	Annual operating	Total annual	
6	0.9	2.46	38,000	6,150	12,600	18,700	7,600
6	0.5	1.36	38,000	6,150	9,700	15,900	11,700
6	0.3	0.82	38,000	6,150	8,280	14,400	17,600

<sup>a</sup>Emission reduction compared to an MD heater with conventional burners.

<sup>b</sup>The capital recovery factor is 0.131.

## 6.5 REFERENCES FOR CHAPTER 6

1. A Study to Assess the Available Technology and Associated Costs of Reducing NO<sub>x</sub> Emissions From the Canadian Petroleum Refining Industry. Canadian Petroleum Products Institute. CPPI Report No. 91-1. November 28, 1990.
2. Technical Support Document for a Suggested Control Measure for the Control of Emissions of Oxides of Nitrogen From Industrial, Institutional, and Commercial Boilers, Steam Generators, and Process Heaters. Air Resources Board and South Coast Air Quality Management District. April 29, 1987.
3. Economic Indicators: Chemical Engineering Plant Cost Index. Chemical Engineering. Vol. 99(3):206. March 1992.
4. OAQPS Control Cost Manual. United States Environmental Protection Agency, Office of Air Quality Planning and Standards. EPA 450/3-90-006. January 1990.
5. Letter and attachments from Moreno, F., Alzeta Corporation, to Sanderford, E., MRI. May 22, 1992. Cost comparison between ND and MD conventional burners versus Alzeta burners.
6. Annual Energy Review 1990. Department of Energy/Energy Information Administration-0384(90). May 1991. p. 157.
7. Letter and attachments from Smith, J., Institute of Clean Air Companies, to W. Neuffer, EPA/ESD. May 14, 1992. Use of catalyst systems with stationary combustion sources.
8. Telecon. Harris, R., MRI, with Davis, L., Exxon, Baton Rouge. February 7, 1992. Low-NO<sub>x</sub> burner retrofits.
9. Letter and attachments from Morrow, N., Exxon Chemical Group, to Harris, R., Midwest Research Institute. Low-NO<sub>x</sub> burner experience at Basic Chemicals plant.
10. Letter and attachments from Pickens, R., Nalco Fuel Tech, to Neuffer, W., EPA/ISB. August 7, 1992. Comments on Draft Alternative Control Techniques Document--Control of NO<sub>x</sub> Emissions from Process Heaters.



11. Letter and attachments from Strickland, G., Chemical Manufacturers Association, to Neuffer, W., EPA/ISB. September 9, 1992. Comments on Draft Alternative Control Techniques Documents--Control of NO<sub>x</sub> Emissions from Process Heaters.
12. California Clean Air Act Guidance. Determination of Reasonably Available Control Technology and Best Available Retrofit Control Technology for Industrial, Institutional, and Commercial Boilers, Steam Generators, and Process Heaters. California Air Resources Board. July 18, 1991.

## 7.0 ENVIRONMENTAL AND ENERGY IMPACTS

This chapter presents the environmental and energy impacts for the NO<sub>x</sub> control techniques described in Chapter 5 for process heaters. The impacts of low-NO<sub>x</sub> burners (LNB's), ultra low-NO<sub>x</sub> burners (ULNB's), flue gas recirculation (FGR), selective noncatalytic reduction (SNCR), and selective catalytic reduction (SCR) on air pollution, solid waste disposal, and energy consumption are discussed. These NO<sub>x</sub> reduction techniques produce no water pollution impacts. Low excess air (LEA), discussed in Section 5.1.1, reduced air preheat (RAP), discussed in Section 5.1.8, and natural draft- (ND) to-mechanical draft (MD) conversion are considered to be operational controls and can have environmental and energy impacts. However, they are not considered NO<sub>x</sub> control techniques and are not discussed separately in this chapter.<sup>1</sup>

This chapter is organized into four sections. Section 7.1 presents air pollution impacts; Section 7.2 presents solid waste impacts; and Section 7.3 presents energy consumption impacts; and Section 7.4 presents the references for this chapter.

### 7.1 AIR POLLUTION IMPACTS

#### 7.1.1 NO<sub>x</sub> Emission Reductions

A summary of the achievable NO<sub>x</sub> emission reductions and controlled emission levels for the process heater control techniques is presented in Tables 5-11 through 5-15. The percent reductions shown in these tables represent average reductions for the combustion control techniques. Average reductions are presented because the reductions from baseline emissions vary

depending on the uncontrolled emission level, draft type, fuel type and whether the heater has an air preheater.

Low-NO<sub>x</sub> burners are designed for ND and MD operation and achieve NO<sub>x</sub> reductions by staged-air or staged-fuel techniques. Emissions reductions for LNB's are approximately 50 percent over conventional burners for both ND and MD LNB's, although one manufacturer reports a 72 percent reduction for a staged-fuel MD LNB.<sup>1,2</sup> Staged-fuel LNB's, discussed in Section 5.1.4, yield the highest NO<sub>x</sub> reductions for LNB's and are designed for firing natural gas or refinery gas. Staged-air LNB's are utilized for fuel oil-firing and are discussed in Section 5.1.3.

Ultra low-NO<sub>x</sub> burners, discussed in Section 5.1.6, are capable of reductions of 52 to 80 percent with an average of approximately 75 percent. The highest reductions by burner technologies are achieved with ULNB's. Ultra low-NO<sub>x</sub> burners usually incorporate internal FGR or steam injection and are designed for natural or refinery gas firing.

Flue gas recirculation, discussed in Section 5.1.5, is usually used in combination with LNB's with total NO<sub>x</sub> reductions of approximately 55 percent over uncontrolled emissions.<sup>3</sup> Heaters using conventional burners and FGR are expected to achieve approximately a 30 percent reduction in NO<sub>x</sub> emissions.

Selective noncatalytic reduction can be used as a sole NO<sub>x</sub> control technique or in combination with LNB's. The reduction efficiency of SNCR ranges from 30 to 75 percent. Selective noncatalytic reduction systems are designed to achieve site-specific permit limits, which accounts for the wide range of reduction efficiencies. Temperature and the ratio of reactant to NO<sub>x</sub> are the factors that affect SNCR reductions the most and are further discussed in Section 5.2. According to Thermal DeNO<sub>x</sub><sup>®</sup> data in Table 5-7 and NO<sub>x</sub>OUT<sup>®</sup> data in Table 5-8, the maximum NO<sub>x</sub> reduction for SNCR on process heaters is approximately 75 percent. A 60 percent NO<sub>x</sub> reduction was used in this study for SNCR performance, based on current literature and average reductions cited in data.

Selective catalytic reduction can be used as a sole NO<sub>x</sub> control technique or in combination with LNB's. Reported reduction efficiencies for SCR range from 64 to 90 percent. Selective catalytic reduction systems are designed to achieve site-specific permit limits, which accounts for the wide range of reduction efficiencies. Temperature and the ratio of reactant to NO<sub>x</sub> strongly affect the performance of SCR and are further discussed in Section 5.3.

According to the data in Appendix D, reductions of 90 percent with LNB's + SCR are achievable. However, on average, SCR provides a 75 percent reduction of NO<sub>x</sub> in the flue gas.<sup>4,5</sup> For the purposes of this study, this 75 percent reduction is used for SCR.

#### 7.1.2 Emissions Trade-Offs

The formation of thermal and fuel NO<sub>x</sub> depend upon combustion conditions. Combustion controls modify the combustion conditions to reduce the amount of NO<sub>x</sub> formed. These modifications may increase carbon monoxide (CO) and unburned hydrocarbon (HC) emissions. Flue gas treatments (SNCR and SCR) reduce NO<sub>x</sub> by injecting a reactant into the flue gas stream. Ammonia (NH<sub>3</sub>), nitrous oxide (N<sub>2</sub>O), CO, and particulate matter (PM) emissions can be produced by SNCR. Ammonia and PM emissions are also produced with SCR. These air pollution impacts are described in the following two sections.

7.1.2.1 Impacts on HC and CO Emissions from the Use of LNB's, ULNB's, and FGR. The extent to which NO<sub>x</sub> emissions can be reduced by combustion controls may be limited by the maximum acceptable increase in CO and HC emissions.<sup>7</sup> Combustion controls for NO<sub>x</sub> reduction discussed in this chapter are LNB's, ULNB's and FGR.

The air pollution impacts for ULNB's and LNB's are similar and are discussed collectively in this chapter as LNB's. Low-NO<sub>x</sub> burners reduce NO<sub>x</sub> formation by reducing the peak flame temperature and/or O<sub>2</sub> concentrations in the flame zone. These burners are more sensitive to LEA controls than conventional

burners. Improper control can cause incomplete combustion and result in increased CO and HC emissions.<sup>6,7</sup>

In a test involving a process heater with LNB's, the effects of excess air on operation, gaseous emissions, and heater efficiency were evaluated. After testing each process heater in the "as-found" condition to establish an emissions baseline, burner registers and/or stack dampers were adjusted to produce different O<sub>2</sub> levels. Figure 7-1 plots the NO<sub>x</sub> emission factors as a function of flue gas O<sub>2</sub> content for the heaters tested. The level of NO<sub>x</sub> decreases as the level of excess O<sub>2</sub> decreases, but below approximately 3 percent excess O<sub>2</sub>, significant CO emissions or visible smoke occurred, and these points are marked in the figure as "CO limits."<sup>8</sup>

Table 7-1 presents a summary of gaseous emissions and efficiencies for each heater tested. A comparison of emissions at the as-found conditions and at optimum low-NO<sub>x</sub> conditions (i.e., lowest NO<sub>x</sub> emissions without adverse effects on flame stability or unit efficiency) is provided in this table. The level of excess air was adjusted to reduce NO<sub>x</sub> emissions with the additional benefit of possibly increasing heater efficiency while maintaining acceptable CO emissions. The lowest as-found NO<sub>x</sub> emission concentration was 77 ppmv with 79.9 percent heater efficiency and 0 ppmv (corrected to 3 percent O<sub>2</sub>) CO emissions. By decreasing the excess O<sub>2</sub> level from 6.2 to 3.0 percent, NO<sub>x</sub> emissions were reduced to 48 ppmv, heater efficiency was increased to 83.0 percent, and CO emissions increased to 20 ppmv (corrected to 3 percent O<sub>2</sub>). The highest as-found NO<sub>x</sub> emission concentration was 168 ppmv with 64.0 percent heater efficiency and 11 ppmv CO emissions (corrected to 3 percent O<sub>2</sub>). By reducing the O<sub>2</sub> level from 5.1 to 4.0, NO<sub>x</sub> emissions were reduced to 145 ppmv, heater efficiency remained at 64.0 percent, and CO emissions remained at 11 ppmv (corrected to 3 percent O<sub>2</sub>).

At most sites, NO<sub>x</sub> emission reductions were achieved with small increases or, at worst, no change, in thermal or fuel efficiency. At the optimum low-NO<sub>x</sub> conditions, flame stability, product flows and temperatures, and emissions of CO and HC, unit

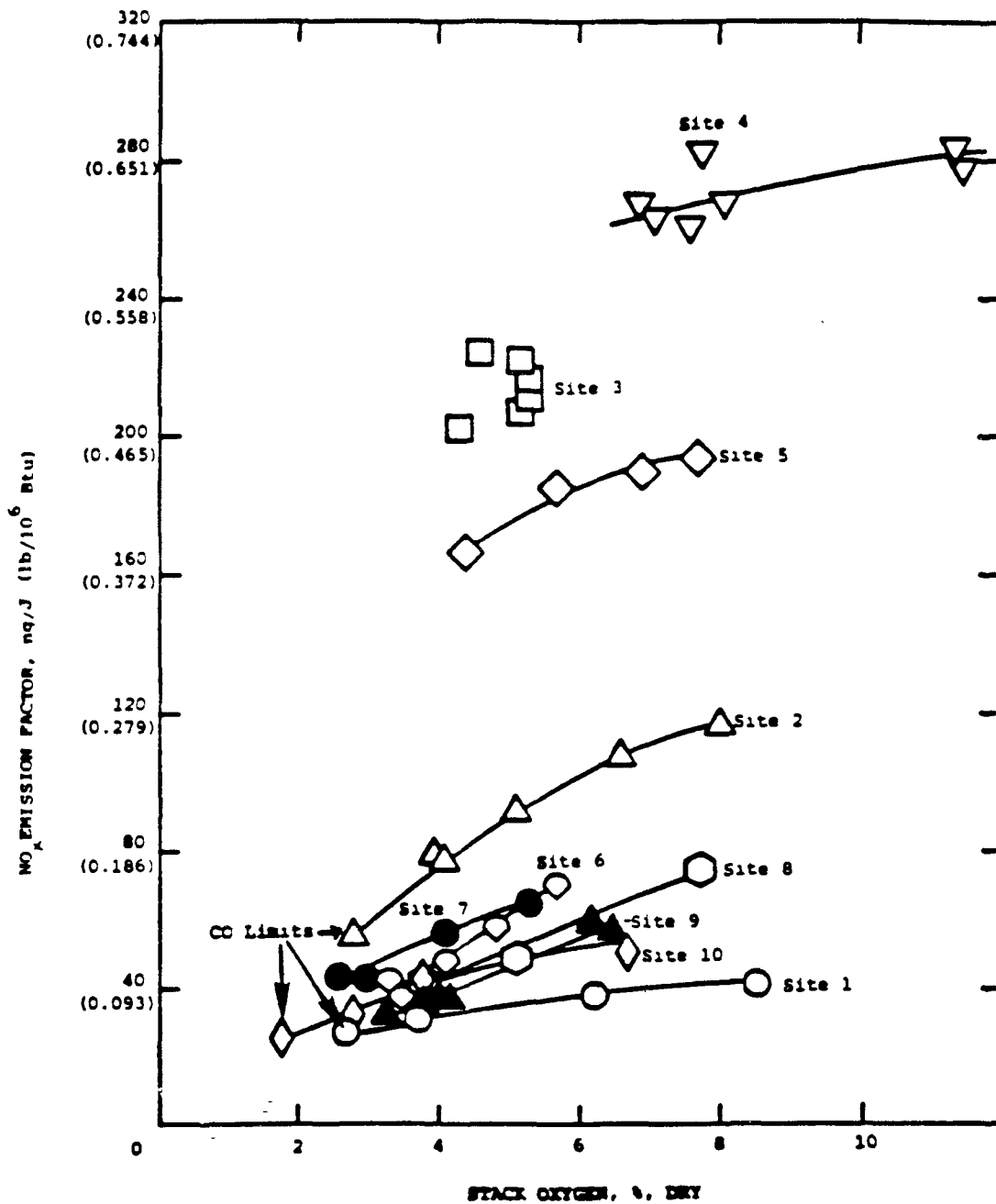

Figure 7-1. NO<sub>x</sub> emission factor for 10 process heaters equipped with low-NO<sub>x</sub> burners as a function of stack oxygen.<sup>8</sup>



operations were generally unchanged from the as-found conditions.<sup>8</sup> The study showed that emissions reductions with LNB's are optimized by controlling the excess air. Furthermore, efficiency gains were achieved by lowering excess O<sub>2</sub> levels to approximately 3 percent. High CO emissions indicate incomplete combustion, which would result in an efficiency loss.

Table 7-2 is a summary of a test with a John Zink PSRF-16M burner that demonstrates the effects of excess air control on the newer generation of LNB's.<sup>2</sup> The data indicate that with proper control there were no CO emissions for excess air levels at or above 3.5 percent. The inverse relationship between NO<sub>x</sub> formation and CO formation is evident at 2 percent excess O<sub>2</sub>, where NO<sub>x</sub> decreased to 29 ppmv but CO increased to 41 ppmv (corrected to 3 percent O<sub>2</sub>).<sup>2</sup>

Data in Tables 7-1 and 7-2 indicate that LNB's are capable of reducing NO<sub>x</sub> without causing excessive CO emissions. The highest CO emissions in Table 7-1 were 33 ppmv at 3 percent O<sub>2</sub>. The highest CO emissions in Table 7-2 were 41 ppmv at 3 percent O<sub>2</sub>. California Air Resources Board's best available retrofit control technology specifies a CO emission limit of 400 ppmv for process heaters with capacities of 5 MMBtu/hr or greater.<sup>2,6,9</sup>

Flue gas recirculation injects relatively inert flue gas into the combustion air, thereby lowering the peak flame temperature and diluting the O<sub>2</sub> concentration. These effects promote CO and HC emissions, but these effects can be minimized with properly designed FGR and excess O<sub>2</sub> systems.<sup>6</sup> As discussed in Chapter 5, data for process heater FGR is limited. However, boiler data indicate that FGR is a viable control technique for process heaters because boilers and process heaters use similar burners and combustion systems. The primary limitation to FGR use on process heaters is the recirculation of high-temperature flue gas. Fans used on process heaters are required to withstand higher temperatures than FGR fans on boilers with economizers. Table 7-3 presents data on the impact of FGR on emissions for a 200-hp firetube boiler.<sup>10</sup> The boiler was operated at 66 and 100 percent load firing natural gas. It was also operated at



TABLE 7-2. NITROGEN OXIDE AND CARBON MONOXIDE EMISSIONS  
 FOR A 20 MMBtu/hr REFINERY HEATER WITH LNB OPERATION  
 (REFINERY FUEL GAS)<sup>2</sup>

O <sub>2</sub> , %	NO <sub>x</sub> , ppm <sup>a</sup>	NO <sub>x</sub> , lb/MMBtu	CO, ppm <sup>b</sup>
2.0	29	0.033	41
3.5	32	0.040	0
4.2	34	0.044	0
4.6	35	0.046	0
5.3	35	0.048	0
5.9	35	0.050	0

<sup>a</sup>Heater is operated with an LEA system.

<sup>b</sup>Corrected to 3 percent O<sub>2</sub>.

TABLE 7-3. NITROGEN OXIDE AND CARBON MONOXIDE EMISSIONS FOR A  
6.7 MMBtu/hr (200 hp) BOILER WITH LNB + FGR<sup>10</sup>

Fuel	Load, %	% FGR	% O <sub>2</sub>	NO <sub>x</sub> , ppm <sup>a</sup>	lb NO <sub>x</sub> / MMBtu	CO, ppm <sup>a</sup>	lb CO/ MMBtu
NG	66	0	4.22	74	0.106	11	0.062
NG	66	16.9	4.30	24	0.035	29	0.017
NG	100	0	4.00	80	0.117	16	0.014
NG	100	12.5	4.67	33	0.048	13	0.012
FO <sup>b</sup>	68	0	3.80	138	0.199	13	0.007
FO <sup>b</sup>	68	18.9	3.70	109	0.158	20	0.012
FO <sup>b</sup>	100	0	4.33	158	0.336	16	0.014
FO <sup>b</sup>	100	14.3	4.07	123	0.265	14	0.012

<sup>a</sup>Corrected to 3 percent O<sub>2</sub>.

<sup>b</sup>No. 2 distillate fuel oil.

68 and 100 percent load firing distillate fuel oil. Emissions were recorded with FGR and without FGR. Firing natural gas at 66 percent load, 0 percent FGR corresponded to NO<sub>x</sub> emissions of 74 ppmv (corrected to 3 percent O<sub>2</sub>) and CO emissions of 11 ppmv (corrected to 3 percent O<sub>2</sub>). Using 16.9 percent FGR, NO<sub>x</sub> emissions decreased to 24 ppmv (corrected to 3 percent O<sub>2</sub>), but CO emissions increased to 29 ppmv (corrected to 3 percent O<sub>2</sub>). Firing natural gas at 100 percent load, 0 percent FGR corresponded to NO<sub>x</sub> emissions of 80 ppmv (corrected to 3 percent O<sub>2</sub>) and CO emissions of 16 ppmv (corrected to 3 percent O<sub>2</sub>). Using 12.5 percent FGR, NO<sub>x</sub> emissions decreased to 33 ppmv (corrected to 3 percent O<sub>2</sub>) and CO emissions decreased to 13 ppmv (corrected to 3 percent O<sub>2</sub>). The use of FGR while firing distillate oil resulted in trends for NO<sub>x</sub> and CO emissions similar to those for natural gas firing. As the percent of recirculated flue gas was increased at partial load, NO<sub>x</sub> decreased, but CO increased. As FGR was increased at full load, NO<sub>x</sub> decreased, and CO decreased. For either natural gas or oil firing, CO decreased at full load because the boiler's combustion efficiency at 100 percent load is greater than at partial load.

7.1.2.2 Impacts on NH<sub>3</sub>, N<sub>2</sub>O, CO, and PM Emissions from the Use of SNCR and SCR. Currently, SNCR and SCR are the only postcombustion NO<sub>x</sub> control techniques available for process heaters. Combustion controls reduce NO<sub>x</sub> emissions by inhibiting NO<sub>x</sub> formation, but SNCR and SCR utilize reactants injected into the flue gas stream to reduce NO<sub>x</sub> that was formed during the combustion process. Air pollution impacts associated with SNCR and SCR are discussed below.

Two SNCR processes for process heaters are currently in use. The processes are based on different reactants. Thermal DeNO<sub>x</sub><sup>®</sup> utilizes NH<sub>3</sub> injection and NO<sub>x</sub>OUT<sup>®</sup> utilizes urea injection.

Emission of unreacted NH<sub>3</sub>, or NH<sub>3</sub> slip, is the primary air pollution impact with the Thermal DeNO<sub>x</sub><sup>®</sup> and NO<sub>x</sub>OUT<sup>®</sup> SNCR processes because of the high reactant-to-NO<sub>x</sub> injection ratio (1.25 to 2.0:1).<sup>6</sup> Figure 7-2 shows that at higher temperatures, when NH<sub>3</sub> and urea are more reactive, NH<sub>3</sub> slip is reduced. In a

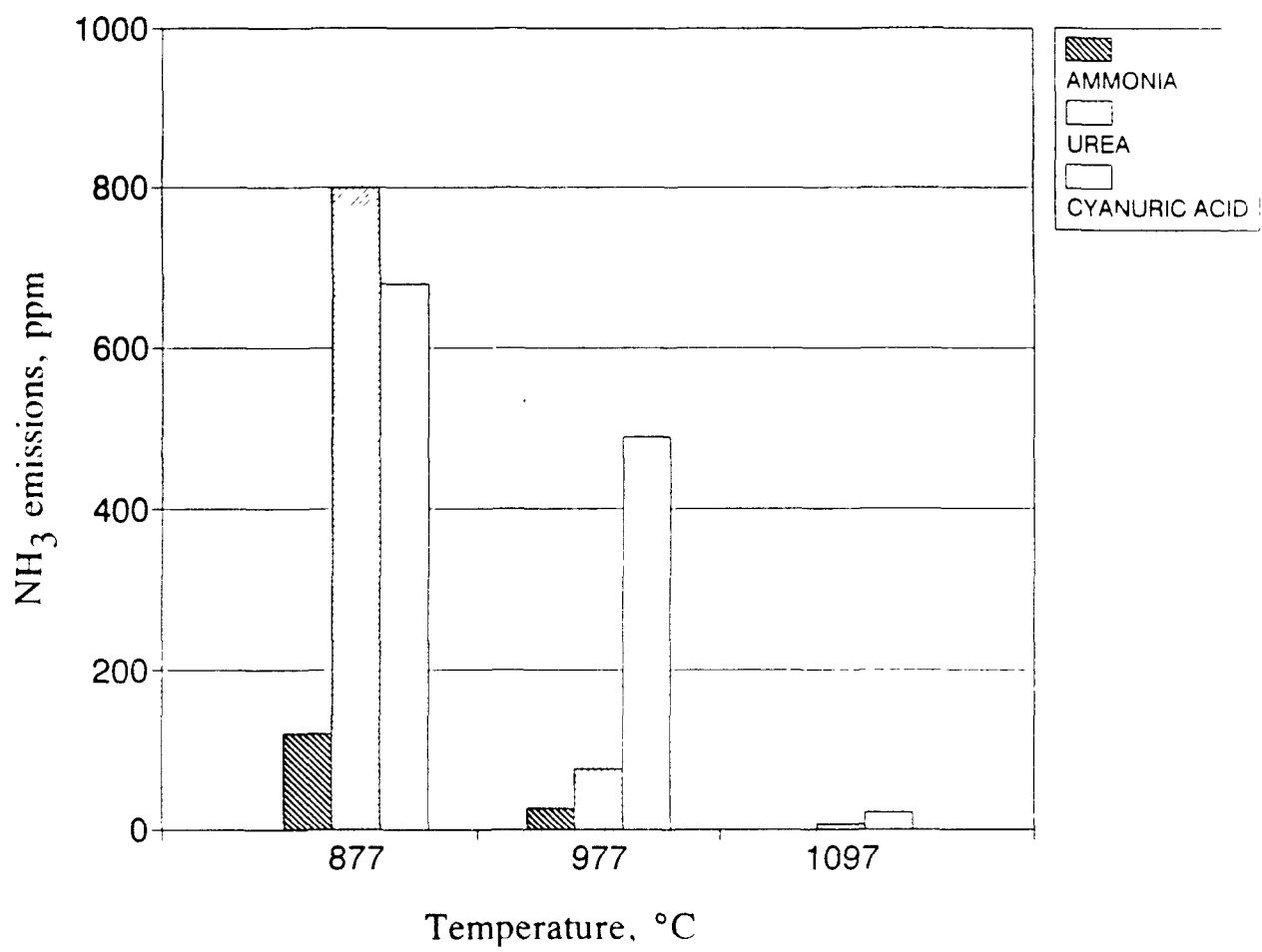

Figure 7-2. Pilot-scale test results, NH<sub>3</sub> emissions.  
 Inlet NO = 700 ppm.<sup>12</sup>

typical refinery heater application, a 70 percent  $\text{NO}_x$  reduction is achievable with an  $\text{NH}_3:\text{NO}_x$  ratio of 1.25 and ammonia slip less than 20 ppmv, the present SCAQMD limit.<sup>3</sup> Therefore,  $\text{NH}_3$  slip problems are not expected with properly designed SNCR systems.

Oil-fired heaters have an additional concern with  $\text{NH}_3$  slip. Ammonium sulfate  $[(\text{NH}_4)_2\text{SO}_3]$  deposits in the convection section of the heater and PM emissions may result from  $\text{NH}_3$  slip with the use of sulfur-bearing fuel oil.<sup>7</sup>

Leaks and spills from  $\text{NH}_3$  storage tanks and piping are safety concerns because liquid or highly concentrated ammonia vapor is hazardous.<sup>3,10</sup> The Occupational Safety and Health Administration standard limits occupational exposure of 50 ppmv for an 8 hour period.<sup>7</sup> However,  $\text{NH}_3$  handling is not expected to present a problem as long as proper safety procedures are followed.

Nitrous oxide and CO have been shown to be byproducts of urea injection.<sup>11,12</sup> Nitrous oxide formation has been shown to be a byproduct of ammonia injection, but studies show these emissions to be less than 20 ppmv.<sup>1,12</sup> While  $\text{N}_2\text{O}$  emissions from conventional combustion equipment are low (less than 15 ppmv for boilers) advanced combustion and emission control techniques could increase  $\text{N}_2\text{O}$  emissions. Nitrous oxide is the largest source of stratospheric  $\text{NO}$ .<sup>12</sup> The following reactions describe the formation of  $\text{N}_2\text{O}$  and CO, where the intermediate species HCNO is a precursor:

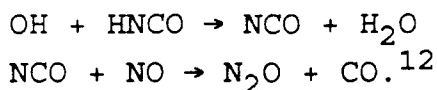

Reduction of  $\text{NO}_x$  with SNCR processes increases with temperature up to approximately 980°C (1800°F) as demonstrated by the results of a pilot scale test presented in Figure 7-3a. Formation of  $\text{N}_2\text{O}$  also increases with temperature as shown in Figure 7-3b. This pilot test showed the potential for  $\text{N}_2\text{O}$  production by SNCR systems on combustion equipment such as boilers and process heaters. For  $\text{NH}_3$  injection, the highest  $\text{NO}_x$  reductions occurred at about 980°C (1800°F) and the peak  $\text{N}_2\text{O}$  emissions (21 ppmv) occurred at about 880°C (1620°F). Urea

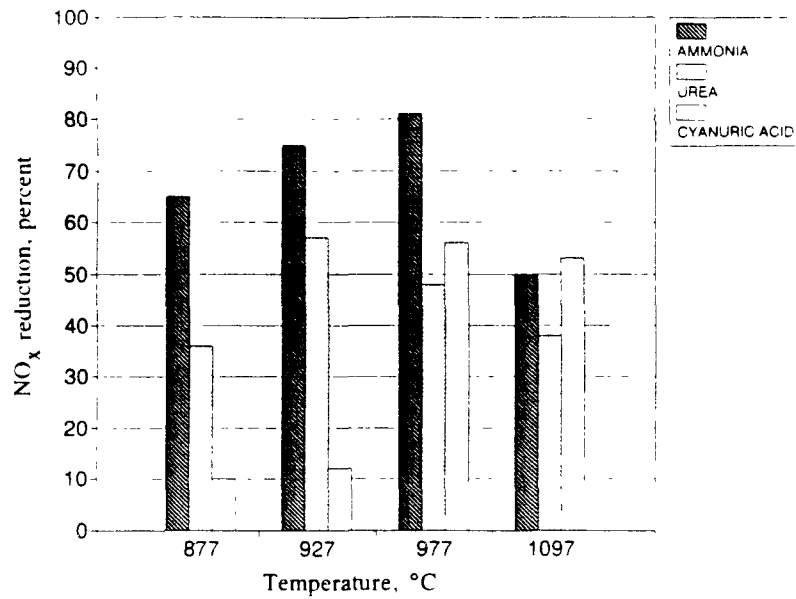

a) NO<sub>x</sub> reduction versus temperature for SNCR processes

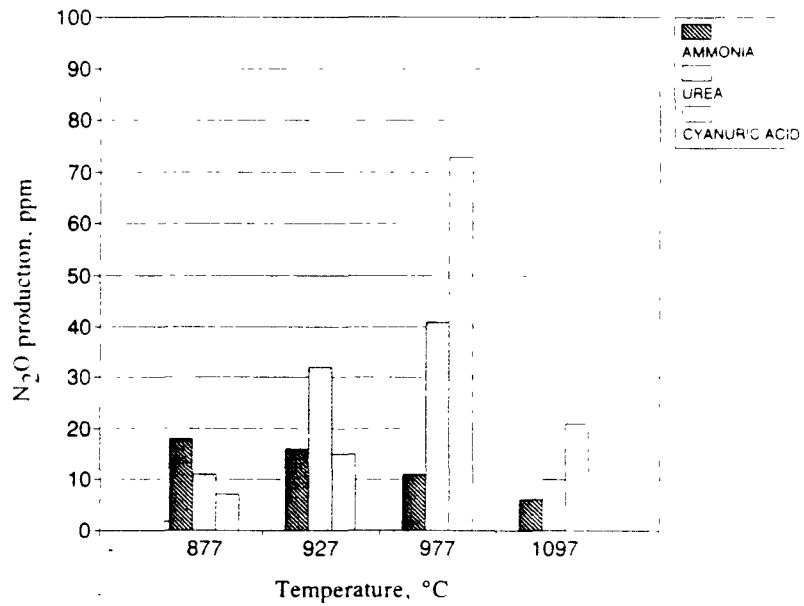

b) N<sub>2</sub>O production versus temperature

Figure 7-3. Pilot-scale test results; NO<sub>x</sub> reduction and N<sub>2</sub>O production versus temperature.<sup>12</sup>

injection resulted in peak  $\text{NO}_x$  reductions and peak  $\text{N}_2\text{O}$  emissions (43 ppmv) occurred at about  $980^\circ\text{C}$  ( $1800^\circ\text{F}$ ).<sup>12</sup>

Ammonia slip concentrations of less than 10 ppmv are expected using SCR for process heaters under steady state conditions.<sup>6,7,9,13</sup> The ratios of  $\text{NH}_3:\text{NO}_x$  (1.00:1 or less to 1.05:1) for SCR are lower than for SNCR, which reduces the potential for unreacted  $\text{NH}_3$  emissions.<sup>11</sup> As with  $\text{NH}_3$  SNCR, ammonia storage and transport safety procedures must be followed.

The bulk of catalysts used in SCR systems in refinery service process heaters contain titanium and vanadium oxides.<sup>3</sup> Catalysts older than 10 years tend to convert up to 5 percent of any  $\text{SO}_2$  present in sulfur-bearing fuels to  $\text{SO}_3$ .<sup>3</sup> Catalysts installed in the last 10 years are designed to convert less  $\text{SO}_2$  to  $\text{SO}_3$ . Utility boilers firing sulfur-bearing fuels and using SCR have demonstrated that conversions of less than one percent are achievable.<sup>13</sup> Sulfuric acid condensation in the flue gas may result from  $\text{SO}_3$  emissions.<sup>14</sup> In addition, formation of  $(\text{NH}_4)_2\text{SO}_3$  from  $\text{SO}_3$  and unreacted  $\text{NH}_3$  can result in deposits in the heater exhaust ducting and PM emissions.<sup>7</sup>

## 7.2 SOLID WASTE IMPACTS

Current combustion controls and SNCR applied to process heaters generate no solid waste. Catalyst materials used in SCR units for process heaters include heavy metal oxides (e.g., vanadium or titanium) precious metals (e.g., platinum), and zeolites. Vanadium pentoxide, the most commonly used SCR catalyst in the United States, is identified as an acute hazardous waste under RCRA Part 261, Subpart D - Lists of Hazardous Wastes. However, the Best Demonstrated Available Technology Treatment Standards for Vanadium P119 and P120 states that spent catalyst containing vanadium pentoxide are not classified as hazardous waste.<sup>15</sup> States and local regulatory agencies are authorized to establish their own hazardous waste classification criteria, and spent catalyst containing vanadium pentoxide may be classified as a hazardous waste in some areas. Although the actual amount of hazardous waste contained in the catalyst bed is small, the volume of the catalyst unit containing

this material is quite large and disposal can be costly. Where classified by State or local agencies as a hazardous waste, this waste is subject to the Land Disposal Restrictions in 40 CFR Part 268, which allow land disposal only if the hazardous waste is treated in accordance with Subpart D - Treatment Standards. Such disposal problems are not encountered with the other catalyst materials, such as precious metals and zeolites, because these materials are not hazardous wastes. Currently, catalyst vendors accept spent catalyst thereby alleviating disposal considerations by SCR operators for all catalyst types.

### 7.3 ENERGY IMPACTS

The energy impacts of NO<sub>x</sub> control techniques applied to process heaters may include additional electrical energy for fans or blowers and lower thermal efficiency. The impacts of LNB's, FGR, SNCR, and SCR are described in the following paragraphs. Currently, no information concerning the energy impacts of ULNB's is available. These impacts are expected to be similar to LNB's.

The electrical energy impacts of NO<sub>x</sub> control techniques include the additional power consumed by fans or blowers and air compressors or pumps. Low-NO<sub>x</sub> burners, in general, do not have any electrical energy impacts. An electric fan to recirculate flue gas in addition to MD operation is required by FGR systems. The aqueous and anhydrous SNCR process require either a compressed or steam carrier system. Air compressors for these processes are electric motor driven, therefore having an electrical energy impact. Selective catalytic reduction systems cause flue gas pressure drops in the order of 25 to 130 mm w.g. (1 to 5 in.) and require additional MD horsepower to overcome the resistance to flow.<sup>7</sup> The additional fan horsepower requirement increases electrical energy usage slightly.

Combustion control techniques may affect the thermal efficiency of process heaters. Reduction of flame temperature generally reduces thermal NO<sub>x</sub> formation, but may decrease the combustion efficiency. Reductions in combustion efficiency usually indicate a reduction in the heater thermal efficiency.



Current LNB's and FGR systems are balanced between optimum NO<sub>x</sub> reduction and acceptable thermal efficiency.

As discussed in Section 7.1.2.1, heaters using LNB's were tested to determine the effects of reducing excess air levels. Maximum combustion efficiency for process heaters is achieved with excess O<sub>2</sub> levels at approximately 3 percent. Thermal energy is absorbed by excess air levels above 3 percent O<sub>2</sub>, which decreases thermal efficiency because the heated excess air carries thermal energy out of the heater with the flue gas. At excess O<sub>2</sub> levels below 3 percent, insufficient O<sub>2</sub> concentrations exist for complete fuel oxidation.

Low-NO<sub>x</sub> burners with LEA are typically slightly more fuel efficient than conventional burners, as is shown in Table 7-1.<sup>4</sup> However, flame instability associated with LNB's can require reduced firing rates and loss of thermal efficiency. Loss of thermal efficiency negates fuel credits derived from burner efficiency gains.<sup>3</sup>

Utilization of FGR systems can affect the thermal efficiency of process heaters, although recirculation of less than approximately 20 percent flue gas does not adversely affect thermal efficiency.<sup>7</sup> The dilution of the combustion air supply with inert products of combustion decreases the thermal efficiency.<sup>6</sup> Losses in efficiency are compensated for by increased fuel firing.

A thermal efficiency penalty of approximately 0.3 percent is associated with SNCR. The NO<sub>x</sub>OUT<sup>®</sup> and aqueous Thermal DeNO<sub>x</sub><sup>®</sup> process heat duty losses are due to the injection of the aqueous reactant and distribution air in the convection section. The anhydrous Thermal DeNO<sub>x</sub><sup>®</sup> process heat duty losses are also due to the dilution of the flue gas with distribution air or steam.<sup>1</sup> These losses result in increased fuel consumption.<sup>3</sup>

A thermal efficiency penalty of approximately 1.5 percent is associated with SCR. Injection of the NH<sub>3</sub> causes heat duty losses similar to those described for SNCR. The pressure drop across the catalyst also causes a thermal efficiency loss. These losses result in increased fuel consumption.

#### 7.4 REFERENCES FOR CHAPTER 7

1. Letter and attachments from Eichamer, P., Exxon Chemical Company, to Neuffer, W., EPA/ISB. September 2, 1992. Comments on Draft Alternative Control Techniques Documents-- Control of NO<sub>x</sub> Emissions from Process Heaters.
2. Waibel, R., PhD. Advanced Burner Technology for Stringent NO<sub>x</sub> Regulations. John Zink Company. Presented at American Petroleum Institute Midyear Refining Meeting. May 8, 1990.
3. A Study to Assess the Available Technology and Associated Costs of Reducing NO<sub>x</sub> Emissions From the Canadian Petroleum Refining Industry. Canadian Petroleum Products Institute. CPPI Report No. 91-1. November 28, 1990.
4. Letter and attachments from Britt, J. Mobil Oil Corporation to Jordan, B., EPA/ESD. April 29, 1992. Process heater NO<sub>x</sub> emission control retrofit experience at Mobil's Terrance, CA petroleum refinery.
5. Letter and attachments from Franklin, H., Foster Wheeler Energy Corporation, to Neuffer, W., EPA/ISB. April 27, 1992. Process heater SCR experience.
6. Gomma, H., L. Hackemesser, and D. Cindric. NO<sub>x</sub>/CO Emissions and Control in Ethylene Plants. Environmental Progress. 10(4):267-272. November 1991.
7. A Suggested Control Measure for the Control of Emissions of Oxides of Nitrogen From Industrial, Institutional, and Commercial Boilers, Steam Generators and Process Heaters. Energy Section, Strategy Assessment Branch, Stationary Source Division Air Resources Board and Rule Development Division, South Coast Air Quality Management District. April 29, 1992.
8. Research and Development, Emissions from Refinery Process Heaters Equipped with Low-NO<sub>x</sub> Burners. Industrial Environmental Research Laboratory. EPA-600/7-81-169. October 1981.
9. California Clean Air Act Guidance. Determine of Reasonably Available Control Technology and Best Available Retrofit Control Technology for Industrial, Institutional and Commercial Boilers, Steam Generators, and Process Heaters California Resources Board. July 18, 1991.
10. Letter and attachments from Erickson, W., Industrial Products, Inc. to Hamilton, R., Texas Air Control Board. June 22, 1990. Flue gas recirculation for NO<sub>x</sub> control.

11. Teixeira, D. Widening the Urea Temperature Window. Paper presented at 1991 Joint Symposium on Stationary Combustion NO<sub>x</sub> Control. Washington, D.C. November 1991.
12. Muzio, L., and T. Montgomery. N<sub>2</sub>O Formation in Selective Non-Catalytic NO<sub>x</sub> Reduction Processes. Paper presented at 1991 Joint Symposium on Stationary Combustion NO<sub>x</sub> Control. Washington, D.C. November 1991.
13. Letter and attachments from Wax, M., Institute of Clean Air Companies, to Neuffer, W., EPA/ISB. August 27, 1992. Comments on Draft Alternative Control Techniques Document-- Control of NO<sub>x</sub> Emissions from Process Heaters.
14. Letter and attachments from Chichanowicz, J., Electric Power Research Institute, to Bradley, M., NESCAUM. November 21, 1991. Comments on the draft document "Evaluation and Costing of NO<sub>x</sub> Controls for Existing Utility Boilers in the NESCAUM Region."
15. 55 FR 22276, June 1, 1990.

APPENDIX A. REFINERY PROCESS HEATER INVENTORY<sup>a</sup>

Heater No	Heater type <sup>b</sup>	Capacity MMBtu/hr <sup>c</sup>	No. of burners in bank <sup>d</sup>	Heater installed date	Draft type <sup>e</sup>	Fuel type <sup>f</sup>	Air preheat, °F <sup>g</sup>	Oxygen content, % O <sub>2</sub> Dry <sup>h</sup>	Heater load, % rated capacity at time of test	10b Uncorrected NO <sub>x</sub> emission factor, lb NO <sub>x</sub> /MMBtu	10c Method of determination
11	DWB	186	32 WF	1942	ND/MD	HPBL	450	3.8	101.7	0.224	CALC
12	HC	96	14 WF	1942	ND/MD	HPBL	510	3.8	20.3	0.296	CALC
13	DWB	189	32 WF	1945	ND/MD	HPBL	500	3.8	75.6	0.241	TEST
14	SWB	56	12 WF	1948	ND/MD	HPBL	560	3.8	95.9	0.257	CALC
15	HC	251	36 FF	1953	ND/MD	HPBL	463	3.8	83.5	0.223 (0.121)	CALC
16	HC	76	24 FF (18)	1953	ND/MD	HPBL	570	3.8	118.7	0.323 (0.121)	CALC
17	HC	251	36 FF	1953	ND/MD	HPBL	463	3.8	106.7	0.223	CALC
19	HC	76	24 FF	1953	ND/MD	HPVI	570	3.8	119.2	0.323	TEST
18	HC	289	24 FF	1967	ND/MD	HPBL	611	3.8	78.6	0.278	TEST
20	HC	117	16 FF	1967	ND/MD	HPBL	615	3.8	96.8	0.279	CALC
65	HC-HW	171	48 FF	1963	ND/MD	NSPS	488	3.8	107.3	0.130	CALC
66	HC-HW	150	48 FF	1968	ND/MD	NSPS	540	3.8	92.4	0.140	TEST
126	HC-HW	113	48 FF	1978	ND/MD	NSPS	534	3.8	107.3	0.137 (0.085)	CALC
127	HC-HW	113	48 FF	1978	ND/MD	NSPS	524	3.8	107.3	0.137	CALC
41	V-C-P	97	8 FF	1958	ND/MD	HPBL	625	3.8	110.9	0.241	TEST
42	V-C	29	4 FF	1958	MD/ND	HPBL	794	3.8	125.1	0.908	CALC
47	HC	61	18 FF	1966	MD/ND	HPBL	670	3.8	92.1	0.189	TEST
118	VTB	255	10 FF	1976	MD	NSPS	725	3.8	84.3	0.167	CALC
119	VTB	255	10 FF	1977	MD	NSPS	725	3.8	79.5	0.167	TEST
128	V-C	161	12 FF	1979	MD/ND	NSPS	500	3.8	64.2	0.128	TEST
131	V-C	80	12 FF	1978	MD/ND	NSPS	640	3.8	66.7	0.157	CALC
129	V-C	50	8 FF	1979	MD/ND	NSPS	640	3.8	106.2	0.157	CALC
72	SHTC	164	24 FF	1969	MD/ND	HPBL	762	3.8	86.2	0.076	CALC

APPENDIX A. (continued)

Heater No	Heater type <sup>b</sup>	Capacity MMbtu/hr <sup>c</sup>	No. of burners in heater <sup>d</sup>	Heater installed date	Draft type <sup>e</sup>	Fuel type <sup>f</sup>	Air preheat, °F <sup>g</sup>	Oxygen content, % O <sub>2</sub> dry <sup>h</sup>	Heater load, % rated capacity at time of test	10h Uncontrolled NO <sub>x</sub> emission factor, lb NO <sub>x</sub> /MMBtu	10h Method of determination
73	SHTC	196	24-FF	1969	MD/ND	HPBL	773	3.8	73.9	0.077	FLST
74	SHTC	111	24-FF	1969	MD/ND	HPBL	625	3.8	120.1	0.062	CALC
21	HC	40	20-FF	1950	ND	HPBL	-AMB-	3.8	50.0	0.111	CALC
43	VC	14	4-FF	1958	ND	HPBL	AMB-	3.8	69.3	0.085	CALC
45	VC	35	7-FF	1958	ND	HPBL	-AMB-	3.8	64.9	0.111	CALC
46	VC	20	4-FF	1958	ND	HPBL	-AMB-	3.8	35.0	0.111	CALC
75	SHTC	151	18-FF	1969	ND	HPBL	-AMB-	3.8	67.5	0.111	CALC
76	VC	45	4-FF	1969	ND	HPBL	-AMB-	3.8	23.3	0.111	CALC
77	VC	23	3-FF	1969	ND	HPBL	AMB	3.8	24.8	0.111	CALC
78	VC	38	6-FF	1969	ND	NSPS	-AMB-	3.8	66.3	0.083	CALC
81	VC	100	12-FF	1969	ND	HPBL	AMB	3.8	87.3	0.071	CALC
82	VC	191	20-FF	1969	ND	HPBL	-AMB-	3.8	80.6	0.071	CALC
48	VTB	120	20-FF	1966	ND	HPBL	AMB-	3.8	52.8	0.071	FLST
100	VC	40	4-FF	1972	ND	HPBL	-AMB-	3.8	26.8	0.071	CALC
105	VC	33	4-FF	1972	ND	HPBL	-AMB-	3.8	64.8	0.083	CALC
116	VC	48	4-FF	1974	ND	NSPS	-AMB-	3.8	95.0	0.083	CALC
133	VC	52	4-FF	1980	ND	NSPS	-AMB-	3.8	27.1	0.077	CALC
117	VC	72	6-FF	1974	ND	NSPS	AMB-	3.8	66.3	0.083	CALC
84	VTB	148	42-FF	1969	ND	HPBL	-AMB-	3.8	56.0	0.064	CALC
85	VC	20	4-FF	1970	ND	HPBL	-AMB-	3.8	72.5	0.111	CALC
24	DWB	24	4-FF	1974	ND	HPBL	-AMB-	3.8	64.5	0.111	CALC
108	VC	15	3-FF	1972	ND	HPBL	-AMB-	3.8	27.3	0.111	CALC
110	VC	82	8-FF	1973	ND	HPBL	-AMB-	3.8	55.9	0.083	CALC
107	VC	122	20-FF	1972	ND	HPBL	-AMB-	3.8	58.9	0.083	CALC

APPENDIX A. (continued)

Heater No.	Heater type <sup>b</sup>	Capacity MMFtu/hr <sup>c</sup>	No. of burners in heater <sup>d</sup>	Heater installed date	Draft type <sup>e</sup>	Fuel type <sup>f</sup>	Air preheat, °F	Oxygen content, % O <sub>2</sub> Dry <sup>g</sup>	Heater load, % rated capacity at time of test	10h Uncontrolled NO <sub>x</sub> emission factor, lb NO <sub>x</sub> /MMBtu	10h Method of determination
28	HC	186	28-FF	1958	ND	HPBL	AMB	3.8	52.4	0.094	CALC
60	VC	121	16-FF	1966	ND	HPRI	AMB	3.8	116.4	0.111	TEST
58	HC	76	12-FF	1953	ND	HPBL	250	3.8	72.8	0.105	CALC
59	HC	61	9-FF	1954	ND	HPBL	250	3.8	81.3	0.105	CALC
55	HC	40	12-WF	1949	ND	HPRI	AMB	3.8	67.5	0.111	CALC
49	VC P	93	7 FF	1973	ND	HPRI	AMB	3.8	37.8	0.111	CALC
51	SWR	20	4-WF	1943	ND	HPBL	AMB	3.8	103.5	0.071	CALC
83	VC	28	4-FF	1972	ND	HPRI	AMB	3.8	17.1	0.106	CALC
109	VC	14	3 FF	1973	ND	HPRI	AMB	3.8	62.9	0.106	CALC
22	VC	16	4-FI	1988	ND	HPBL	AMB	3.8	18.8	0.083	CALC
40	COB	576	15 WF	1966	MD	HPRI/CO	AMB	6.7	99.1	0.21	CALC

<sup>a</sup>Reference 16 from Chapter 5.

<sup>b</sup>VC = Vertical cylinder, VC P = vertical cylinder, petrochem; SWB = single wing box, DWB = double wing box, HC = horizontal cabin with hot wall, HCHW = horizontal cabin with hot wall; SHTC = single hoop tube cabin; VTB = vertical tube box; and COB = carbon monoxide boiler.

<sup>c</sup>Design basis, actual varies.

<sup>d</sup>FF = wall-fired and FF = floor-fired.

<sup>e</sup>ND = Natural draft and MD = mechanical draft.

<sup>f</sup>HPBL = High pressure burner line fuel gas; and NSPS = new source performance standard fuel gas.

APPENDIX B. CURRENT AND FUTURE NO<sub>x</sub>OUT<sup>®</sup> APPLICATIONS<sup>a</sup>

Unit type	Fuel	Size MW <sup>b</sup>	NO <sub>x</sub> baseline ppm	Guaranteed % reduction	Temperature °F	\$/ton NO <sub>x</sub> removed/year
Tang-fired	Bituminous	75	200	30	1800-2000	913
T-fired	Coal	75	200	30	1800-2000	913
Tower	#6 fuel oil	150	200	75	1300-2100	NA
Zurn stoker	Wood waste	44	150	60	1850	NA
Pulverized coal test unit	Bituminous coal	2	200	85	1200-1850	NA
Cell-fired	Wood waste	13	200	60	1700-2000	955
Hydrograte Detroit Stoker	Bark, CH <sub>4</sub>	39.5	85-125	35	1700-1800	NA
Incinerator	Waste gas	8	130-260	60-80	1600-1800	NA
Front-fired	#6 fuel oil	30	300	65	1500-2000	NA
CE stoker	Coal	200	356	40	1950-2070	591
Incinerator Thermal	Contaminated soil	1.9	600-1000	60	2190	NA
Moving grate incinerator	MSW	264 TPD	200	68	1200-1800	NA
On-going utility boiler	Oil	325	220	60	2100	NA
Ethylene cracker	Natural gas	NA	90	55	1922	NA
Cat cracker	Crude		30-50	10	1400	NA
Detroit Stoker	MSW	300 TPD	110	60	1300-1600	NA
Pilot unit	Coal	0.47	220	50	1520-1580	NA
Moving grate incinerator	MSW	360 TPD	200	70	1600-2000	NA
Front-fired Ind. boiler #3	Paper	7.2	392	50	1890-1910	670
Front-fired Ind. boiler #4	Fiber waste	17.2	526	50	1884-1962	670
Moving grate	MSW	528 TPD	183	62	1650	NA
Stoker-fired	Wood	35	140	52	1850-1950	
Grate-fired	Wood	19	145	30	NA	1258
CFB	Wood waste	0.341	125	60	1575-1650	NA
Bottom-fired process heater	Refinery gas, CH <sub>4</sub>	17.7	38-50	35-60	1800-2000	1180

APPENDIX B: (continued)

Unit type	Fuel	Size MW <sup>b</sup>	NO <sub>x</sub> baseline ppm	Guaranteed % reduction	Temperature °F	\$/ton NO <sub>x</sub> removed/year
Side-fired process heater	Refinery gas, CH <sub>4</sub>	5	65	50-75	1800-2000	1180
CFB	Coal	45	250	54	1200-1600	629
GT/HRSG	Refinery Gas	63	75	50	1650	660
Volund grate-fired	MSW	10.8	300	50	NA	778
Front-fired	#6 Fuel Oil	850	450	50	1300-1900	NA
CFB	Bituminous Coal	40	130	70-80	1580	NA
Moving grate incinerator	Tires	7.5	85	40	1800-2000	NA
Sludge Combustor	Paper sludge, CH <sub>4</sub>	6	570	50	1800	865
CFB/limestone	Coal	29.8	40	33	1700-1850	NA
CFB	Low sulfur coal	0.256	150	67	1400-1500	NA
CFB	Bituminous coal	12	175	88	1600	NA
Package boiler	#6 fuel oil	10.3	105	27-40	1700-1800	NA
Riley Stoker	Wood	22.5	NA	25	1800	2229
Pulverized coal corner-fired	Brown coal	150	250	70	1200-2100	NA
Pulverized coal corner-fired	Brown coal	75	150	65	1200-1950	NA
Front-fired	Natural gas	110	150	45	1600-1900	NA
Front-fired	#6 fuel oil	110	240	70	1600-1900	NA
Grate fired	Hog fuel oil, bark	90	270	50	1900-2200	580
Glass furnace	Natural gas	NA	1000	55	1675	NA
Waste heat boiler	Refinery gas	66.5	230	65	NA	439
Pulverized coal front-fired	Bituminous Coal	50	650	83	1300-2000	NA
Industrial	#6 fuel oil	8.53	120	60	1500-2000	NA
Pilot/CFB	Coal	1	178	54	1715	NA



APPENDIX B: (continued)

Unit type	Fuel	Size MW <sup>b</sup>	NO <sub>x</sub> baseline ppm	Guaranteed % reduction	Temperature °F	\$/ton NO <sub>x</sub> removed/year
CFB	Wood	28	150	70	NA	NA
Grate type	Wood waste	190 (MMBtu/hr)	70-120	42-78	1680	NA
NA	Coal	5	NA	NA	NA	NA
Moving grate incinerator	MSW	32.5	240	65	1700-1900	NA
Grate-fired	Tires	17	80	50		1,418
Future tangentially fired utility boiler	Oil	185	200	50	1950-2100	363
Stoker boiler	Biomass	44	150	50	1850	614
Cell-fired	Wood waste	13	200	60	1700-2000	955
Grate-fired	Tires	17	80	50	1900-2050	1418
Package boiler	Landfill gas	17	25	NA	NA	NA
Recovery boiler	Black liquor	72	60	60	NA	NA
Fluidized bed furnace	Organic gases (contains nitrogen)	1.6	130-160	50-60	1800	3,073
Calciner	Heat coke	NA	NA	50	NA	NA

NA = Not available

<sup>a</sup>Reference 26 from Chapter 5.

<sup>b</sup>Rated power output.

APPENDIX C. LIST OF PROCESS HEATER NO<sub>x</sub> CONTROL RETROFITS FOR MOBIL TORRANCE REFINERY<sup>a</sup>

Heater	Capacity, MMBtu/hr	Preretrofit control technology	Preretrofit NO <sub>x</sub> emissions, lb/MMBtu	Post-retrofit control technology	Post-retrofit NO <sub>x</sub> emissions, lb/MMBtu	NO <sub>x</sub> emission reductions, %
IF-1	457	LNB	0.056	SCR	0.02	64.3
IF-2	161	LNB	0.0773	SCR	0.05	74.1
2F-2	108	LNB	0.0553	ULNB	0.05	9.6
3F-1A	17.2	None	0.15	ULNB	0.0327	78.2
3F-18	17.2	None	0.15	ULNB	0.035	76.7
3F-2A	21.1	None	0.15	UNLB	0.040	73.3
3F-2B	21.1	None	0.15	ULNB	0.031	79.3
3F-3	129	LNB	0.0819	ULNB	0.07	14.5
3F-4	73	LNB	0.1127	ULNB	0.07	37.9
4F-1	527	None	0.2288	ULNB	0.06	73.8
6F-1	39.6	None	0.07	ULNB	0.032	54.3
6F-2	64	None	0.1607	ULNB	0.06	62.7
19F-1	288	LNB	0.0877	SCR	0.020	77.2
20F-2	220	LNB	0.1002	SCR	0.020	80.0
22F-2	91	LNB	0.0793	LNB	0.10	
22F-3	91	None	0.115	LNB	0.10	13.0
50F-1	12	None	0.12	UNLB	0.0375	68.8

<sup>a</sup>Reference 14 from Chapter 5.

APPENDIX D. FOSTER WHEELER PROCESS HEATER SCR INSTALLATIONS<sup>a</sup>

Date of installation	11/82	6/83	8/83	1/86	7/86	8/86	8/86	10/90	8/90	12/93	12/92	12/92
Type	PH	PH	PH	PH	PH	PH	PH	PH	PH	PH	PH	PH
Fuel	Gas	Gas	Gas, SO <sub>x</sub> = 12 ppm	Gas	Gas, SO <sub>x</sub> = 17 ppm	Gas	Gas	Gas, SO <sub>x</sub> = 23 ppm	Gas	Gas	Gas	Gas
Additional NO <sub>x</sub> Control	N/A <sup>b</sup>	N/A	N/A	N/A	N/A	N/A	N/A	LNB	N/A	N/A	N/A	N/A
Inlet gas flow, ft <sup>3</sup> /hr	3.6 x 10 <sup>6</sup>	3.2 x 10 <sup>6</sup>	1.0 x 10 <sup>6</sup>	11.8 x 10 <sup>6</sup>	1.9 x 10 <sup>6</sup>	0.5 x 10 <sup>6</sup>	0.7 x 10 <sup>6</sup>	8 x 10 <sup>6</sup>	5 x 10 <sup>6</sup>	2.3 x 10 <sup>6</sup>	15 x 10 <sup>6</sup>	5 x 10 <sup>6</sup>
Inlet temperature, °F	680	700-750	700-750	580	630	725	720	625	680	700	695	600
Catalyst material	V <sub>2</sub> O <sub>5</sub>	V <sub>2</sub> O <sub>5</sub>	V <sub>2</sub> O <sub>5</sub>	V <sub>2</sub> O <sub>5</sub>	V <sub>2</sub> O <sub>5</sub>	V <sub>2</sub> O <sub>5</sub>	V <sub>2</sub> O <sub>5</sub>	V <sub>2</sub> O <sub>5</sub>	V <sub>2</sub> O <sub>5</sub>	V <sub>2</sub> O <sub>5</sub>	V <sub>2</sub> O <sub>5</sub>	V <sub>2</sub> O <sub>5</sub>
Support material	T <sub>2</sub> O <sub>2</sub>	T <sub>2</sub> O <sub>2</sub>	T <sub>2</sub> O <sub>2</sub>	T <sub>2</sub> O <sub>2</sub>	T <sub>2</sub> O <sub>2</sub>	T <sub>2</sub> O <sub>2</sub>	T <sub>2</sub> O <sub>2</sub>	T <sub>2</sub> O <sub>2</sub>	T <sub>2</sub> O <sub>2</sub>	T <sub>2</sub> O <sub>2</sub>	T <sub>2</sub> O <sub>2</sub>	T <sub>2</sub> O <sub>2</sub>
Support configuration	Honeycomb	Honeycomb	Honeycomb	Honeycomb	Honeycomb	Honeycomb	Honeycomb	Honeycomb	Honeycomb	Honeycomb	Honeycomb	Honeycomb
Pressure drop, in H <sub>2</sub> O	2.5	2.0	3.5	0.9	0.8	0.7	0.1	1.3	1.5	2.6	3.3	3.0
Inlet conditions--NO <sub>x</sub> ppm	105	100	80	267	38	45	45	96	60	65	80	74
Guaranteed percent NO <sub>x</sub> reduction	40	90	75	55	47	56	56	90	N/A	<50 ppm	N/A	N/A
Guaranteed NH <sub>3</sub> SLIP, ppm	10	10	10	10	10	10	10	10	20	5	10 @ 3% O <sub>2</sub>	10 @ 3% O <sub>2</sub>
Design NH <sub>3</sub> /NO <sub>x</sub>	1.0	1.0	0.9	0.6	0.7	0.8	0.8	1.0	N/A	1.0	1.02	1.01
Guaranteed catalyst life, years	2	2	2	3	3	3	3	3	3	3	3	3

<sup>a</sup>Reference 29 from Chapter 5

N/A = not available.

**TECHNICAL REPORT DATA**

*(Please read instructions on the reverse before completing)*

1 REPORT NO EPA-453/R-93-034		2	3 RECIPIENT'S ACCESSION NO	
4 TITLE AND SUBTITLE Alternative Control Techniques Document--NO <sub>x</sub> Emissions from Process Heaters			5. REPORT DATE September, 1993	
7 AUTHOR(S) Ed B. Sanderford, Jr.			6. PERFORMING ORGANIZATION CODE	
9 PERFORMING ORGANIZATION NAME AND ADDRESS Midwest Research Institute 401 Harrison Oaks Boulevard, Suite 350 Cary, North Carolina 27513-2412			8 PERFORMING ORGANIZATION REPORT NO	
12 SPONSORING AGENCY NAME AND ADDRESS U.S. Environmental Protection Agency Emission Standards Division (MD-13) Office of Air Quality Planning and Standards Research Triangle Park, N. C. 27711			10 PROGRAM ELEMENT NO	
			11 CONTRACT GRANT NO  68-D1-0115	
15 SUPPLEMENTARY NOTES  EPA Work Assignment Manager: William Neuffer (919) 541-5435			13. TYPE OF REPORT AND PERIOD COVERED	
			14 SPONSORING AGENCY CODE	
16 ABSTRACT  This Alternative Control Techniques document describes available control techniques for reducing NO <sub>x</sub> emission levels from refinery and chemical industry process heaters. This document contains information on the formation of NO <sub>x</sub> and uncontrolled NO <sub>x</sub> emissions from process heaters. The following NO <sub>x</sub> control techniques for process heaters are discussed: low-NO <sub>x</sub> burners (LNB), ultra-low NO <sub>x</sub> burners (ULNB), flue gas recirculation (FGR), selective noncatalytic reduction (SNCR), and selective catalytic reduction (SCR). For each control technique, achievable controlled NO <sub>x</sub> emission levels, capital and annual costs, cost effectiveness, and environmental and energy impacts are presented.				
17 KEY WORDS AND DOCUMENT ANALYSIS				
a DESCRIPTORS		b IDENTIFIERS/OPEN ENDED TERMS		c. COSATI Field Group
Refinery and Chemical Industry Process Heaters Control Techniques for NO <sub>x</sub> Emissions Low-NO <sub>x</sub> Burners (LNB) Ultra-Low NO <sub>x</sub> Burners (ULNB) Selective Noncatalytic Reduction (SNCR) Selective Catalytic Reduction (SCR) Flue Gas Recirculation (FGR) Costs of NO <sub>x</sub> Emission Control				
18 DISTRIBUTION STATEMENT		19 SECURITY CLASS (This Report)		21 NO OF PAGES 190
		20 SECURITY CLASS (This page)		22. PRICE